

SmartActuator Series

ICM Plus

INTEGRATED CONTROL MOTOR

ENDURANCE TECHNOLOGYSM

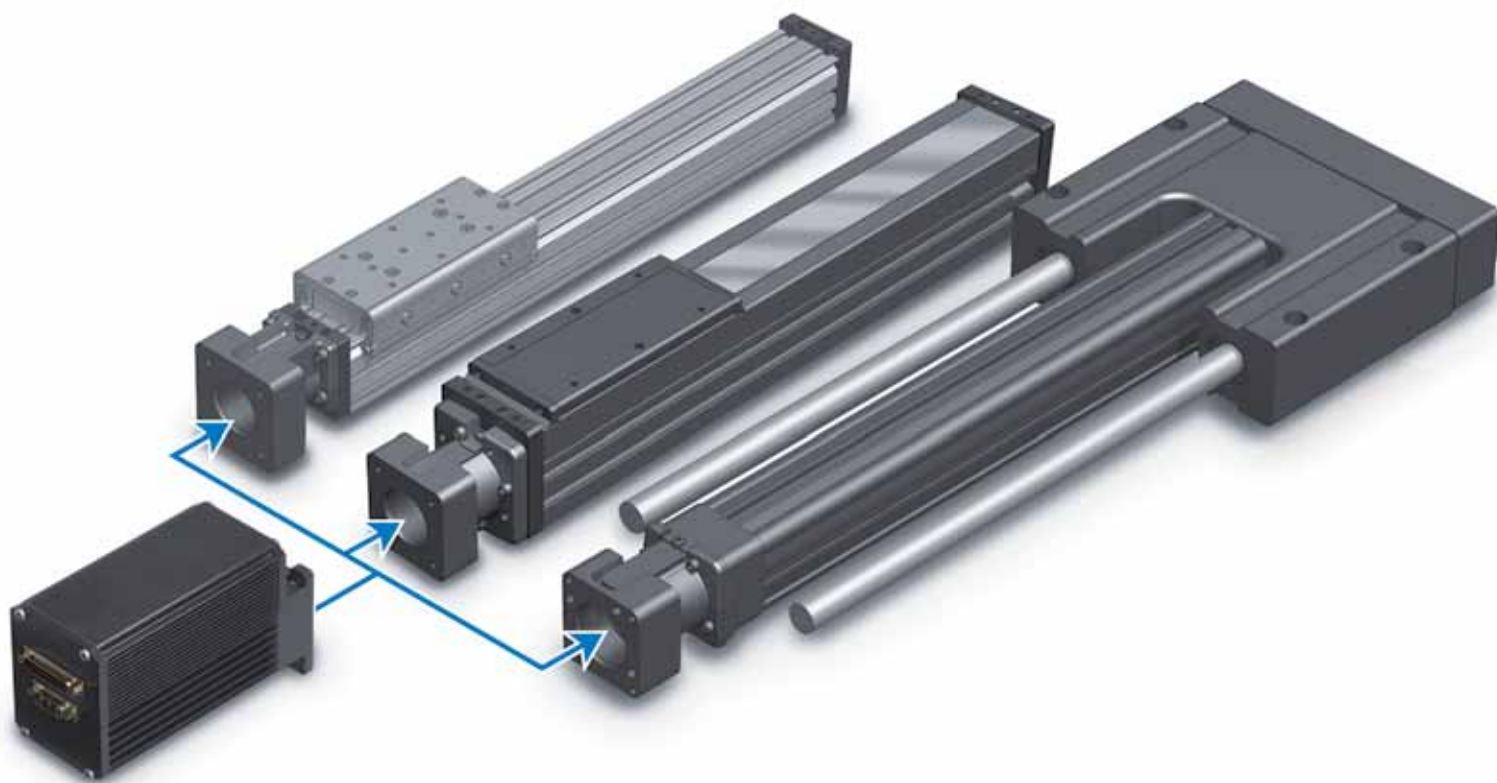

Sold & Serviced By:

ELECTROMATE

Toll Free Phone (877) SERV098

Toll Free Fax (877) SERV099

www.electromate.com

sales@electromate.com

LINEAR SOLUTIONS MADE EASY

What is a **SmartActuator**?

The SmartActuator is a controller, drive and motor integrated with an actuator for an all-in-one solution. Tolomatic has over 50 years of experience manufacturing rodless and rod-style electric and pneumatic actuators. The SmartActuator puts this experience and the intelligence of powerful digital drive technology into one actuator. The result: reliable, affordable power that is remarkably easy-to-use.

About the **ICM Plus**

The ICM Plus creates an all-in-one (control, drive, motor, actuator) affordable solution mounted to your choice of Tolomatic electric rodless or rod-style. The ICM Plus is designed for industrial applications, by combining a flexible integrated digital drive with the power of a servo motor.

Capabilities

- Indexer programming
- Infinite positioning
- Stand-alone operation
- Mid-stroke positioning with sensors
- Stepper mode (pulse/direction)
- Analog position mode
- 100% duty cycle for continuous operation
- 24 Vdc opto-isolated I / O, NPN or PNP
 - 8 Inputs
 - 2 Outputs
- IP65 option - For protection against water and dust ingress



The **ICM Plus** means flexibility

Screw-drive or belt-drive; rod style or rodless; inline or reverse-parallel; the ICM Plus expands your options to include nearly the entire line of Tolomatic electric actuators.

Sold & Serviced By:

 **ELECTROMATE**

Toll Free Phone (877) SERV098

Toll Free Fax (877) SERV099

www.electromate.com

sales@electromate.com

Choose the **Smart**Actuator for these advantages:

vs PNEUMATIC / HYDRAULIC CYLINDERS

- More cost effective to operate
 - Less power consumption
- No costly and messy leaks
- Fewer, cleaner components
 - Eliminates valves, hoses, condensers, mufflers, filters, lubricators, compressors
- Precise control of position, speed, acceleration and force
- Quiet operation
- Accurately positions load at multiple and repeatable locations
- Ability to synchronize motion with other machine operations

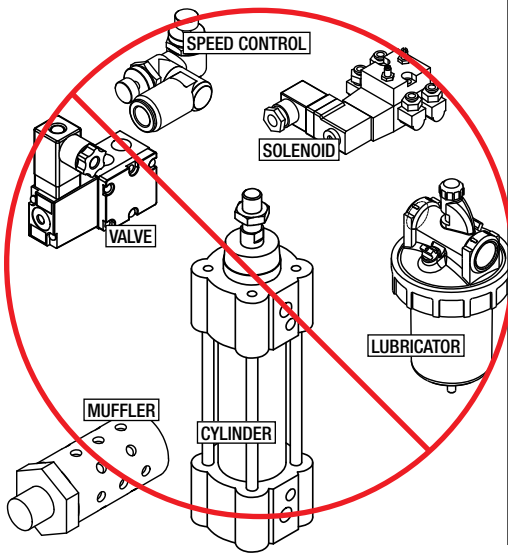

vs INTEGRATED STEPPER ACTUATOR

- True closed loop control ensures position is actually met
- Servo motors supply 100% duty cycle vs. stepper motors which typically supply less than 50% duty cycle
- Expanded speed/torque capability

SPEED vs THRUST
ICM Motor & Integrated Stepper Motor

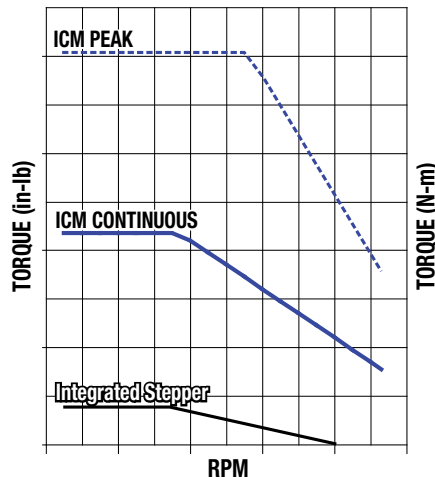

vs TRADITIONAL ELECTRIC SYSTEMS

- Fewer components to purchase and assemble
 - Eliminates separate actuator, motor, drive, cables, coupler and motor mount
- Eliminates need for additional cabinet space: smaller footprint
- Approximately 1/2 the cost of traditional electric actuator systems

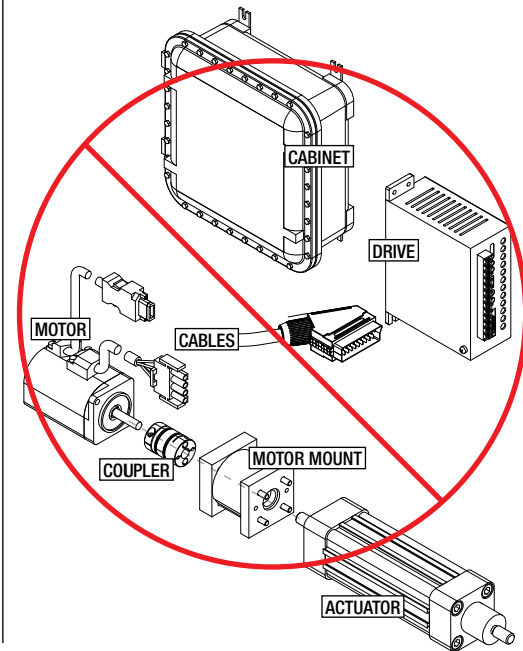

CONTENTS

What is the SmartActuator?.....2	Modes of Operation4	ICM Specifications & Performance..... 6
ICM Plus Introduction2	Flexible Operation4	ICM Dimensions.....7
Smart Actuator Advantages3	ICM Plus Features.....5	Ordering.....8

ICM Plus Modes of Operation

(choose one)

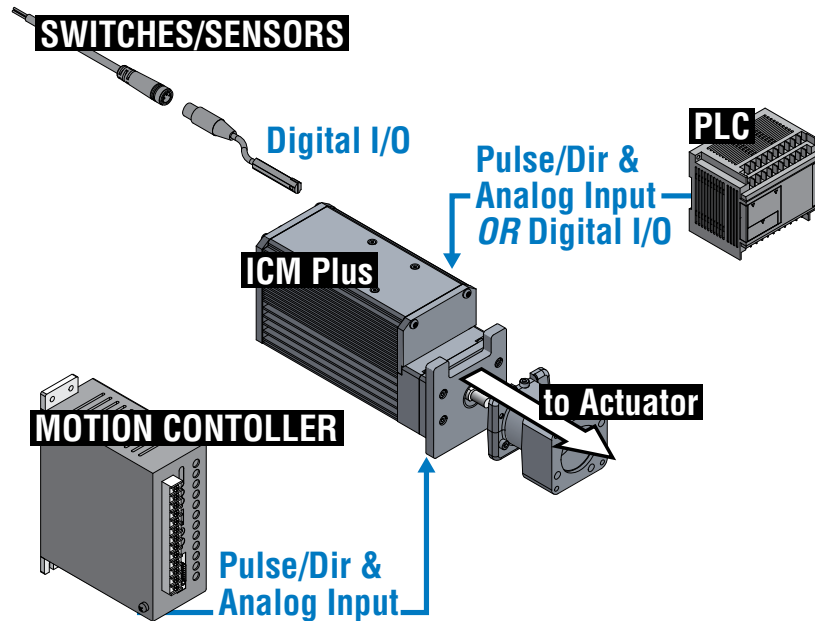

Powerful Software - Intuitive Interface

Input / Output



Control Panel



Indexer Programming



Oscilloscope

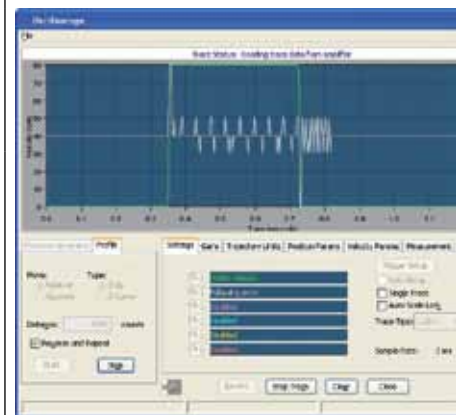

Flexible Operation

Stand-alone mode: PLCs or switches/sensors can send commands to the actuator via digital I/O to invoke indexer program for motion or other logic events.

Communication mode: PLC or PC sends position commands or register changes over RS-232.

Stepper mode: PLC or motion controller sends pulse/direction commands to actuator initiating motion.

Analog position mode: PLC or motion controller sends 0 - 10 VDC analog signal to actuator which equates into an actual position (contact factory for Analog Torque Mode).

Sold & Serviced By:

ELECTROMATE

Toll Free Phone (877) SERV098

Toll Free Fax (877) SERV099

www.electromate.com

sales@electromate.com

SmartActuator ICM Plus

INTEGRATED CONTROL MOTOR

ENDURANCE TECHNOLOGYSM

Endurance Technology features are designed for maximum durability to provide extended service life. This endurance technology symbol indicates our durability design features.

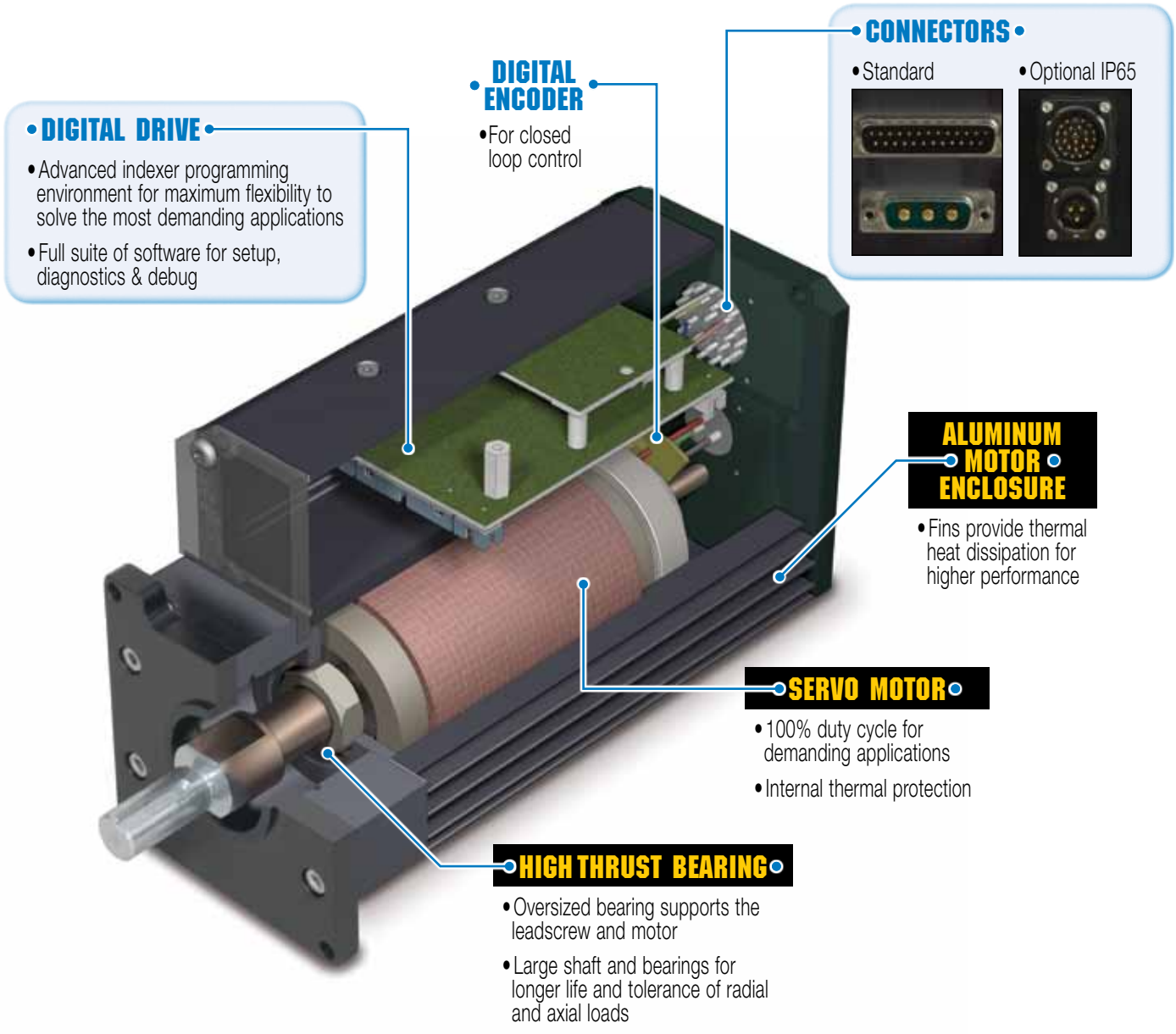

OPTIONS

BRAKE  For vertical applications and energy savings when ICM is not in use

IP65  For protection against water and dust ingress

CABLES 

- Signal Cable (5m, IP40 or IP65)
- Power Cable (5m, IP40 or IP65)

Sold & Serviced By:

 **ELECTROMATE**

Toll Free Phone (877) SERV098
 Toll Free Fax (877) SERV099
www.electromate.com
sales@electromate.com

MECHANICAL SPECIFICATIONS

	Unit	ICM
Peak Torque	in-lb	17
	<i>N-m</i>	<i>1.92</i>
Cont. Torque	in-lb	8.0
	<i>N-m</i>	<i>0.9</i>
Base Weight	lb	6.50
	<i>kg</i>	<i>2.95</i>
Min temp	deg F	50
	<i>deg C</i>	<i>10</i>
Max temp	deg F	122
	<i>deg C</i>	<i>50</i>

NOTE: Performance de-rating will be necessary at ambient temperatures greater than 25 deg. C (77 deg F)

IP rating	std	40
IP rating	option	65

RoHS COMPLIANT RoHs Compliant Components
 CE Approval Pending

POWER SUPPLY

POWER SUPPLY SIZING GUIDELINES

The ICM Plus is intended to run off an isolated DC power source. The power supply that is required will depend on the application. A 48V supply will allow the actuator to operate at maximum speed. A 24V supply will result in half the rated velocity. Input current will depend on the actuator power needed in the application. If operating more than one actuator on the same power supply add the required power supply rating for each actuator. Call Tolomatic for help in determining power supply for your application.

ICM (Required Power - Watts)

SPEED (RPM)	TORQUE (in-lb)							
	2	4	6	8	10	12	14	16
200	28	44	65	91	121	156	196	240
400	38	60	87	119	155	197	243	293
600	48	76	109	147	190	238	290	347
800	59	93	132	176	225	279	338	402
1000	70	110	154	205	260	321	387	458
1200	81	127	177	234	295	363	435	514
1400	93	144	200	263	331	405	485	571
1600	105	161	224	292	367	448	535	628
1800	117	179	247	322	403	491	585	686
2000	129	197	271	352	440	535	636	745
2200	142	215	295	382	477	579		
2400	155	233	319	413	514			
2600	168	252	344	444				
2800	182	271	369					
	<i>0.23</i>	<i>0.45</i>	<i>0.68</i>	<i>0.90</i>	<i>1.13</i>	<i>1.36</i>	<i>1.58</i>	<i>1.81</i>
	TORQUE (N-m)							

Use this table to help determine the proper power source rating for an application. NOTE: green numbers indicate power supply required in Watts for the given speed and thrust indicated at outside margins.

SYSTEM POWER OVERLOADING CONSIDERATIONS

For applications with large load requirements, care should be taken to prevent the system from generating adverse amounts of power, resulting in overloading and possible failure of the actuator.

Vertical applications or applications with large inertia loads may cause regenerative energy to be created. If regenerative energy becomes an issue a shunt regulator will be needed to dissipate excess energy.

Use the Tolomatic Shunt Regulator (part #2180-9811) for preventing over-voltage conditions. Screw terminals are marked with "+" and "-" which should be connected to the power bus.

Sold & Serviced By:



Toll Free Phone (877) SERV098
 Toll Free Fax (877) SERV099
www.electromate.com
sales@electromate.com

MOTOR SPEED vs TORQUE

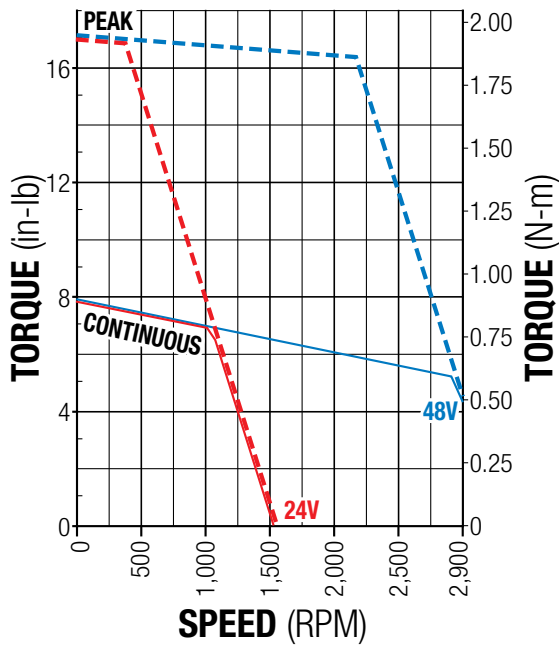

Test conditions: Motor operated at rated temperature mounted to an aluminum heatsink. Aluminum heatsink: 11" x 11" x 1/2"

BRAKE CONSIDERATIONS

An unpowered ICM will require a brake to maintain its position if an external torque is applied.

A brake can be used with the ICM motor to keep the actuator from backdriving, typically in vertical applications. A brake may be used for safety reasons or for energy savings allowing the actuator to hold position when unpowered.

NOTE: The optional Spring-Applied/Electronically-Released Brake requires 24V power. It has a input current rating of 0.414 Amps.

DIMENSIONS

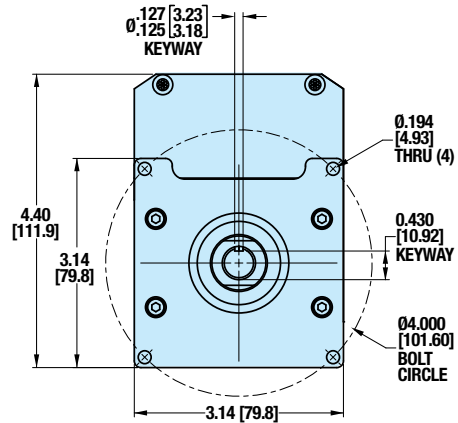
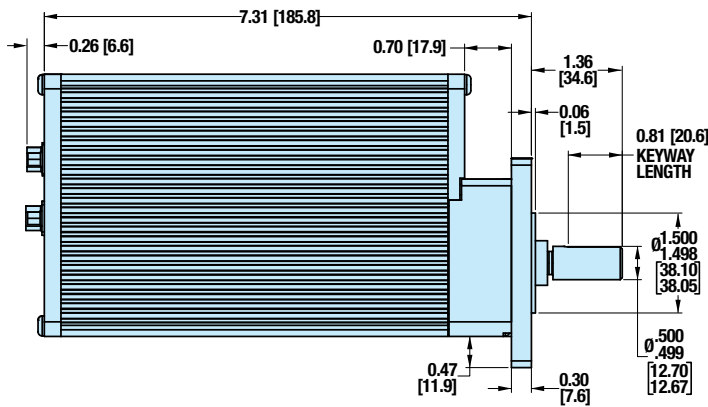

STANDARD CONNECTORS

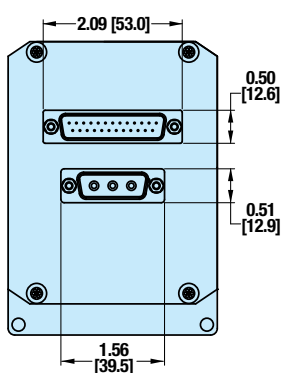

IP65 CONNECTORS

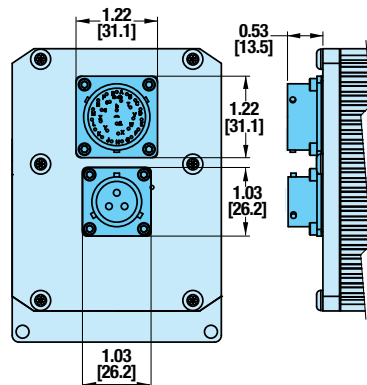

BRAKE OPTION LENGTH

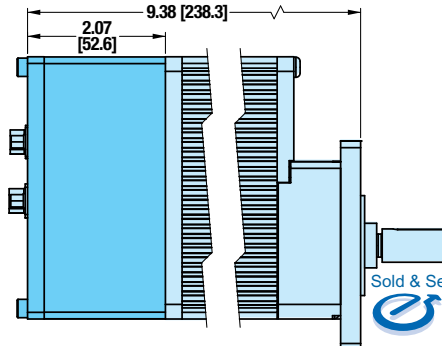

Sold & Serviced By:



Toll Free Phone (877) SERV098
 Toll Free Fax (877) SERV099
www.electromate.com
sales@electromate.com

ORDERING

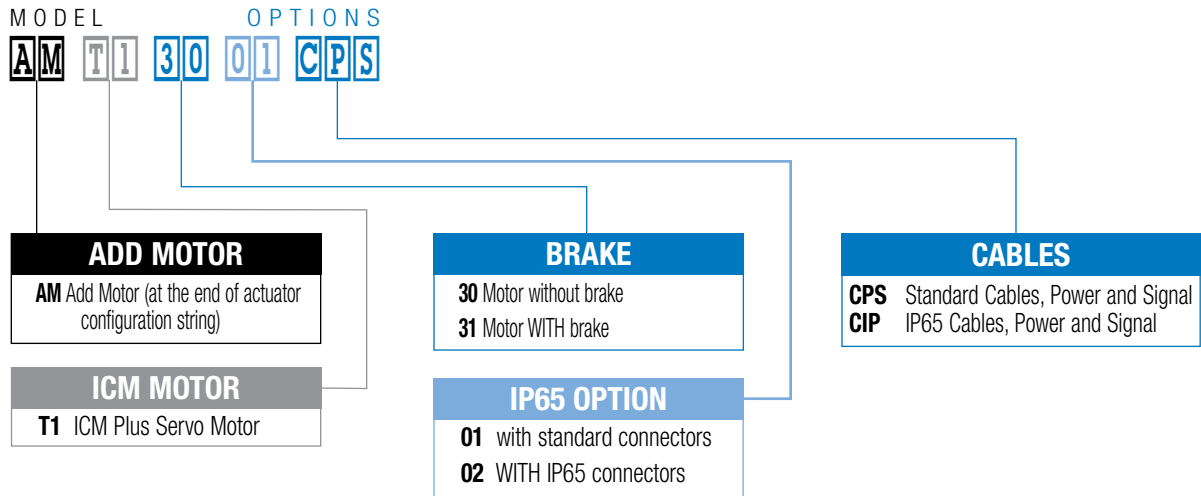

OPTIONS

Description	Part Number	Cable Length
CABLES: ICM Plus		
Signal Cable: IP40	3604-1640	5m
Signal Cable: IP65	3604-1648	5m
Power Cable: IP40	3604-1641	5m
Power Cable: IP65	3604-1649	5m

Description	Part Number
MISCELLANEOUS: ICM Plus	
Shunt Regulator	2180-9811

Not all codes listed are compatible with all options.

Sold & Serviced By:



Toll Free Phone (877) SERV098
Toll Free Fax (877) SERV099
www.electromate.com
sales@electromate.com