

Precise detection even at long ranges

FT 55-RLHM – remarkably reliable

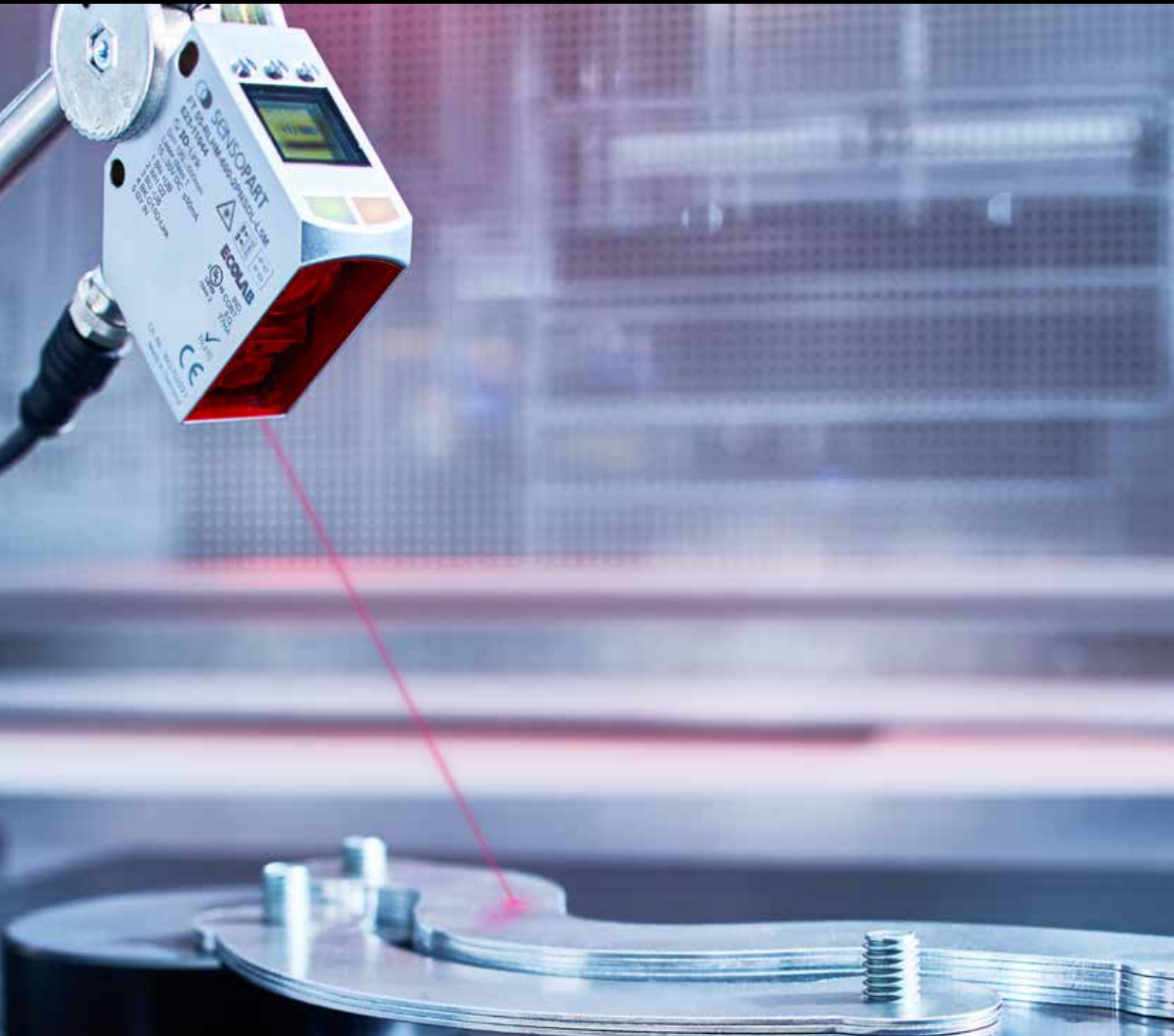

FT 55-RLHM

Maximum operating range, minimum hysteresis



Reliable detection of the smallest objects even at long distances!

The **FT 55-RLHM** reliably detects black to shiny surfaces. A black object measuring just 2 mm in size can be reliably recognised even at a distance of 1 m.

Sensor setup is quick and simple thanks to user-friendly operating elements and an LCD display in which the distance value is continuously visible. This makes **FT 55-RLHM** the most efficient sensor of its category. Pre-configured application modes make settings particularly reliable and simple.

HIGHLIGHTS FT 55-RLHM

- Detection of the smallest objects even at long distances (up to 1 m)
- Extremely stable presence detection even in challenging applications
- No blind zone in 'Detect all' mode
- Special mode for stacking height measurement
- Easy to operate thanks to LCD display and feedback function
- Fast setup thanks to continuous distance indicator in display
- Laser class 1 – for optimum security
- IO-Link – a future-proof interface that meets the demands of Industry 4.0
- Robust metal housing – sensor durability even in challenging processes



The expert for challenging object detection

Thanks to excellent sensor characteristics and a number of different operating modes, **FT 55-RLHM** is the perfect solution for many areas of application. The special stacking height measurement mode can be used to check whether too many, too little or the right number of metal sheets are present. "Detect All" mode identifies all deviations from the reference object (e.g. the background) – whether with regard to the surface, distance or deflected laser light beam – and with no blind zone. Due to its extensive scope of performance, the sensor is suitable for countless challenging applications in a variety of different sectors, particularly those in which precision and reliability are key factors.

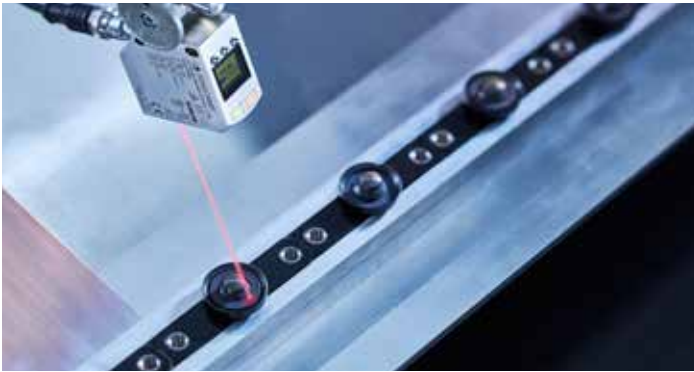

Detecting the presence of black objects on a black background



Detecting the presence of weld nuts



Stacking height measurement of cardboard

Typical sectors:

- Automotive
- Metal processing
- Machine construction
- Packaging technology

FT 55-RLHM-600

Diffuse laser sensor with background suppression

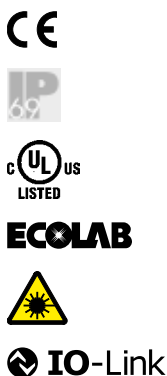
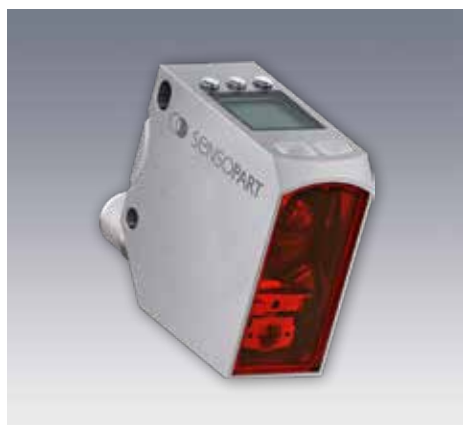

PRODUCT HIGHLIGHTS

- Switching hysteresis of 1.2 enables smart part detection even at large distances up to 600 mm
- Display for a higher level of user-comfort and a fast and easy setup of the sensor
- Most stable presence check thanks to intelligent evaluation algorithm

Optical data		Functions	
Scanning distance	120 ... 600 mm / 0 ... 600 mm ¹	Indicator LED 1, green	Operating voltage indicator
Hysteresis ²	1.2 mm (adjustable)	Indicator LED 2, yellow	Status indicator Q ₁ / Q ₂
Type of light	Laser, red 655 nm	Measurement range adjustment	Via display or IO-Link
Immunity to ambient light	≤ 20,000 lux	Adjustment possibilities	Teach-in Q ₁ , Q ₂ , Q as switching window or switching point; Setting of mean value Auto-Detect / NPN / PNP / Push-Pull Smart Functions (On-delay and drop-out delay, counter, impulse, frequency)
Light spot size (w x h)	4 x 1 mm		
Laser class (IEC 60825-1)	1		
Electrical data		Mechanical data	
Operating voltage +U _b	15 ... 30V DC	Dimensions	50 x 50,5 x 25 mm
No-load current I ₀	≤ 50 mA	Enclosure rating	IP 67 & IP 69 ⁴
Power consumption	≤ 1.5 W	Material, housing	Zinc die-cast, matt chrome
Output current I _e Q	≤ 50 mA	Material, front screen / Display	PMMA
Protection circuits	Reverse polarity protection U _b / short-circuit protection (Q)	Type of connection	Plug, M12x1, 5-pin
Protection class	2	Ambient temperature: operation	-20 ... +50 °C ⁵
Power On Delay	< 300 ms	Ambient temperature: storage	-20 ... +60 °C
Switching output Q	Auto-Detect ³ / PNP / NPN / Push-Pull	Weight (plug device)	185 g
Output function	N.O./N.C.	Resistance to vibration and impacts	EN 60947-5-2
Switching frequency f (ti/tp 1:1) Q	≤ 1000 Hz (adjustable)	Display	LCD, with background illumination
Response time Q	600 μs		
Warm-up time	20 min.		
IO-Link			
Communication mode	COM 2		
Min. cycletime	3 ms		
SIO mode	Compatible		
Length process data	16 Bit		
Data Storage	compatible		
Specification	1.1		
Smart sensor profile	V 1.0		

¹ In Detect All mode ² 5 ... 90 %; homogenous object, not moving ³ Auto-Detect: Automatic selection of PNP or NPN by the sensor; PNP or NPN can be fixed

⁴ With connected IP 67 / IP 69 plug ⁵ UL: max. +45 °C

Scanning distance	Switching output	Type of connection	Part Number	Article number
120 ... 600 mm	Auto-Detect	Plug, M12x1, 5-pin, IO-Link	FT 55-RLHM-600-2PNSDL-L5M	623-11044

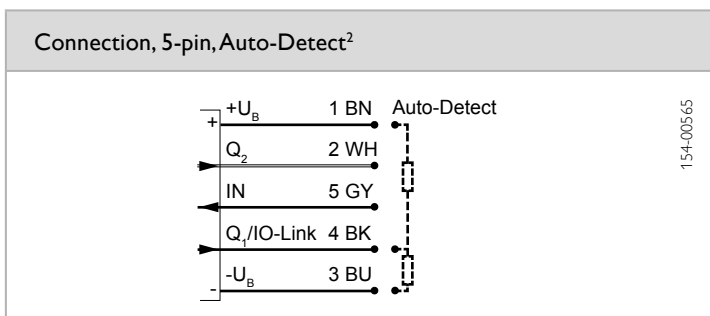
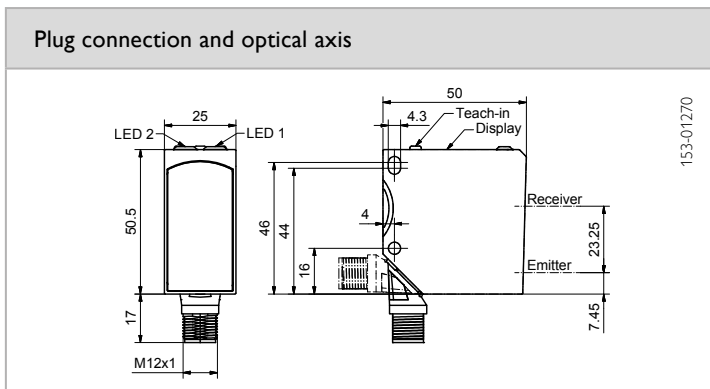

² In IO-Link mode, a 4-pin cable must be used

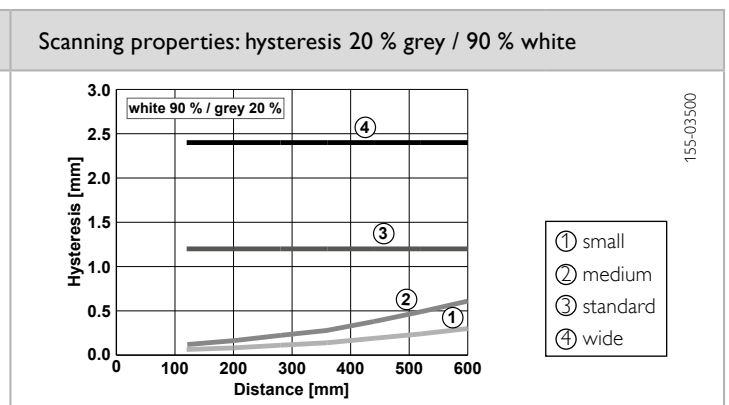
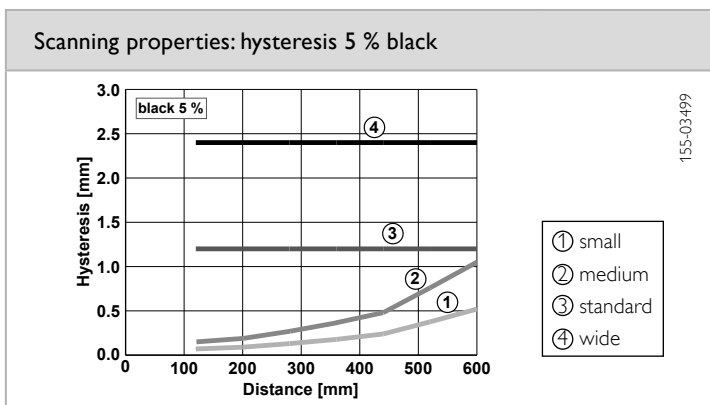

Reference material	Detection range
White (90 %)	120 ... 600 mm
Grey (20 %)	120 ... 600 mm
Black (5 %)	120 ... 600 mm

Default setting	Accessories
Switching output Q ₁	600 mm, N.O.
Switching output Q ₂	
	Connection cable M12 4-pin to M12 4-pin for SensoIO (L4/L4-2m-PUR / 902-51873) [†]
	Further connection cables
	Bracket SensoClip MBD F 55ST2 (579-50012)
	SensoIO (901-01000)

FT 55-RLHM-1000

Diffuse laser sensor with background suppression

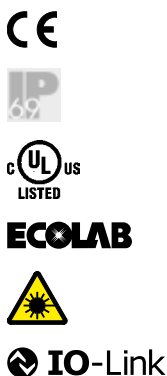

PRODUCT HIGHLIGHTS

- Switching hysteresis of 2 enables smart part detection even at large distances up to 1000 mm
- Display for a higher level of user-comfort and a fast and easy setup of the sensor
- Most stable presence check thanks to intelligent evaluation algorithm

Optical data		Functions	
Scanning distance	200 ... 1000 mm / 0 ... 1000 mm ¹	Indicator LED 1, green	Operating voltage indicator
Hysteresis ²	2 mm (adjustable)	Indicator LED 2, yellow	Status indicator Q ₁ / Q ₂
Type of light	Laser, red 655 nm	Measurement range adjustment	Via display or IO-Link
Immunity to ambient light	≤ 20,000 lux	Adjustment possibilities	Teach-in Q ₁ , Q ₂ , Q as switching window or switching point; Setting of mean value Auto-Detect / NPN / PNP / Push-Pull Smart Functions (On-delay and drop-out delay, counter, impulse, frequency)
Light spot size (w x h)	4 x 1 mm		
Laser class (IEC 60825-1)	1		
Electrical data		Mechanical data	
Operating voltage +U _b	15 ... 30V DC	Dimensions	50 x 50,5 x 25 mm
No-load current I ₀	≤ 50 mA	Enclosure rating	IP 67 & IP 69 ⁴
Power consumption	≤ 1.5 W	Material, housing	Zinc die-cast, matt chrome
Output current I _e Q	≤ 50 mA	Material, front screen / Display	PMMA
Protection circuits	Reverse polarity protection U _b / short-circuit protection (Q)	Type of connection	Plug, M12x1, 5-pin
Protection class	2	Ambient temperature: operation	-20 ... +50 °C ⁵
Power On Delay	< 300 ms	Ambient temperature: storage	-20 ... +60 °C
Switching output Q	Auto-Detect ³ / PNP / NPN / Push-Pull	Weight (plug device)	185 g
Output function	N.O./N.C.	Resistance to vibration and impacts	EN 60947-5-2
Switching frequency f (ti/tp 1:1) Q	≤ 1000 Hz (adjustable)	Display	LCD, with background illumination
Response time Q	600 μs		
Warm-up time	20 min.		
IO-Link			
Communication mode	COM 2		
Min. cycletime	3 ms		
SIO mode	Compatible		
Length process data	16 Bit		
Data Storage	compatible		
Specification	1.1		
Smart sensor profile	V 1.0		

¹ In Detect All mode ² 5 ... 90 %; homogenous object, not moving ³ Auto-Detect: Automatic selection of PNP or NPN by the sensor; PNP or NPN can be fixed

⁴ With connected IP 67 / IP 69 plug ⁵ UL: max. +45 °C

Scanning distance	Switching output	Type of connection	Part Number	Article number
200 ... 1000 m	Auto-Detect	Plug, M12x1, 5-pin, IO-Link	FT 55-RLHM-1000-2PNSDL-L5M	623-11043

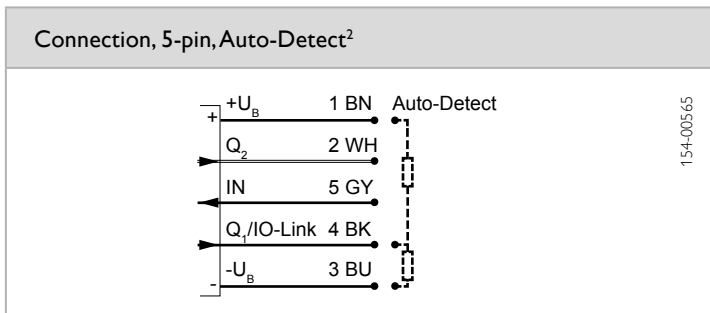
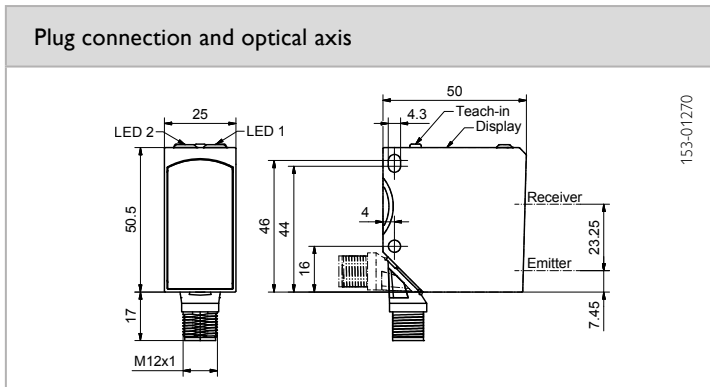

² In IO-Link mode, a 4-pin cable must be used

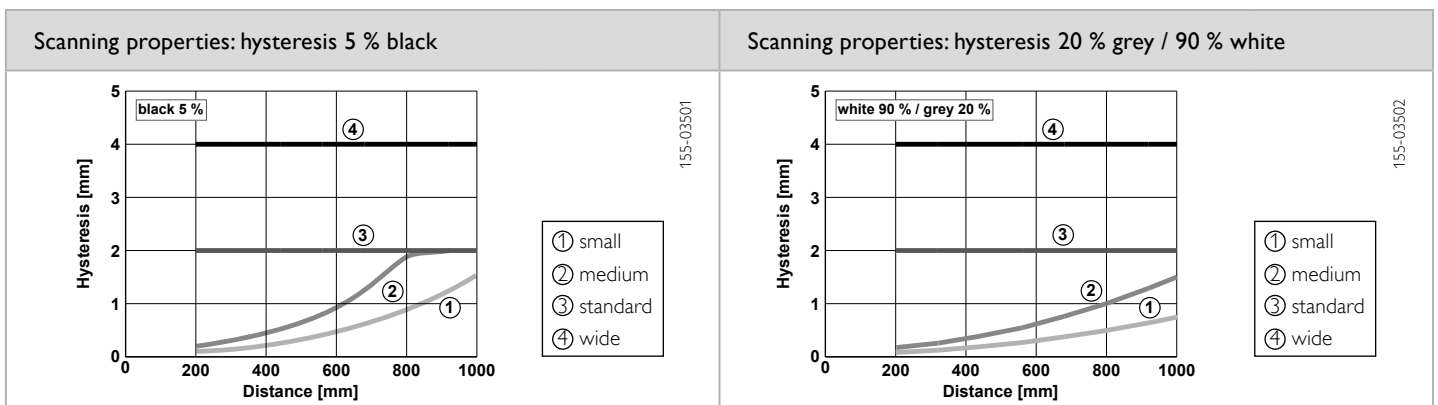

Reference material	Detection range
White (90 %)	200 ... 1000 mm
Grey (20 %)	200 ... 1000 mm
Black (5 %)	200 ... 1000 mm

Default setting	Accessories
Switching output Q ₁	Connection cable M12 4-pin to M12 4-pin for SensoIO (L4/L4-2m-PUR / 902-51873) [†] Further connection cables Bracket SensoClip MBD F 55ST2 (579-50012) SensoIO (901-01000)
Switching output Q ₂	

We look ahead

Yesterday, today and in the future



"We gauge ourselves not by what is possible today, but by our vision of what can be achieved" – this has been our motto since the foundation of SensoPart in 1994. Our goal is to always be a step ahead and to be able to offer our customers the most innovative sensor for industrial automation.

True to this motto, we offer easy-to-integrate VISOR® vision sensors and compact laser sensors with outstanding background suppression made in Germany.

We still also have plenty of ideas for the future - watch this space.

SENSOR TECHNOLOGY

Light barriers
Diffuse sensors
Laser sensors
Miniature sensors
Distance sensors
Color sensors
Contrast sensors
Anti-collision sensors
Slot sensors
Fiber-optic sensors
Inductive sensors
Ultrasonic sensors

Vision sensors
Smart cameras
Vision systems
Object detection
Object measurement
Color detection
Code reading
Lighting
Lenses

Sold & Serviced By:



Canadian and International Sales

ELECTROMATE

877-737-8698

sales@electromate.com

www.electromate.com

U.S. Sales

SERVO2GO.com

877-378-0240

sales@servo2go.com

www.servo2go.com