



## LINEAR BEARINGS and Recirculating Units

# Contents

<b>1</b>	<b>Foreword</b>	Page 3
<hr/>		
<b>2</b>	<b>Useful guidelines</b>	
	2.1 2D- and 3D-drawings	Page 4
	2.2 Regulations governing substances and limit values	Page 4
	2.3 Index and type designations	Page 5
	2.4 Description of the units	Page 9
<hr/>		
<b>3</b>	<b>Product overview</b>	
	3.1 Overview of linear guideways	Page 11
	3.2 Overview of recirculating units	Page 13
	3.3 Earlier generations of the product	Page 14
	3.4 Slideways	Page 15
	3.5 Application-specific solutions	Page 15
<hr/>		
<b>4</b>	<b>Examples of use</b>	Page 17
<hr/>		
<b>5</b>	<b>Linear guideway product specifications</b>	
	5.1 Type R and RD	Page 21
	5.2 Type RN	Page 31
	5.3 Type RNG	Page 37
	5.4 Type N/O	Page 45
	5.5 Type M/V	Page 53
<hr/>		
<b>6</b>	<b>Recirculating unit product specifications</b>	
	6.1 Type SK and SKD	Page 62
	6.2 Type SKC	Page 65
	6.3 Type SR	Page 68
	6.4 Type NRT (with NRV)	Page 71
<hr/>		
<b>7</b>	<b>Options for linear guideways</b>	
	7.1 Quality classes (SQ and SSQ)	Page 75
	7.2 Guideways made of corrosion-resistant steel	Page 75
	7.3 Run-ins rounded	Page 76
	7.4 Multi-part linear guideways	Page 76
	7.5 Height-matched guideways	Page 77
	7.6 DURALLOY® coating	Page 77
	7.7 DryRunner coating	Page 78
	7.8 Cage control FORMULA-S	Page 79
	7.9 Cage control types N/O and M/V	Page 80
	7.10 Fixing holes	Page 80

# Contents

<b>8</b>	<b>Options for recirculating units</b>	
	8.1 Matched recirculating units	Page 85
	8.2 Central lubricating system for NRT recirculating units	Page 86
<hr/>		
<b>9</b>	<b>Standard parameters for linear guideways</b>	
	9.1 Quality classes	Page 87
	9.2 Tolerance of the supporting surface to the track	Page 87
	9.3 Length tolerances and distances between fixing holes	Page 88
	9.4 Operating temperatures	Page 88
	9.5 Speeds and accelerations	Page 88
	9.6 Friction, running accuracy and smoothness	Page 88
<hr/>		
<b>10</b>	<b>Standard parameters for recirculating units</b>	
	10.1 Operating temperatures	Page 89
	10.2 Speeds and accelerations	Page 89
	10.3 Friction, running accuracy and smoothness	Page 89
<hr/>		
<b>11</b>	<b>Design</b>	
	11.1 Linear guideways	Page 90
	11.2 Recirculating units	Page 93
<hr/>		
<b>12</b>	<b>Load carrying capacity and service life</b>	
	12.1 Basic principles	Page 95
	12.2 Short strokes	Page 96
	12.3 Calculating service life	Page 97
	12.4 Example calculations	Page 103
	12.5 Elastic deformation and rigidity	Page 112
<hr/>		
<b>13</b>	<b>Construction and installation guidelines</b>	
	13.1 Connecting structure	Page 117
	13.2 Configuring the connecting structure	Page 117
	13.3 Installation methods	Page 120
	13.4 Fastening	Page 124
	13.5 Preloading	Page 126
	13.6 Sealing and covers	Page 133
	13.7 Lubrication	Page 134
	13.8 Transport, handling and storage	Page 136
	13.9 Assembly guidelines	Page 136
<hr/>		
<b>14</b>	<b>Order descriptions</b>	Page 140

In 1923 SCHNEEBERGER laid the foundations of what is today global linear motion technology. SCHNEEBERGER standards then made it possible to build linear guideways, which in terms of loading capacity, reliability and cost-effectiveness set new standards and soon defined what is today the definitive industry standard.

The same principles that were the reason for our success, informing our way of thinking and acting apply today as previously: the spirit of innovation, a no-compromise approach to quality and the ambition to deliver to our customers products that are technically and economically superior again and again. Both then and today the name SCHNEEBERGER throughout the world is synonymous with modern linear guide technology. Our core competencies, development, production and application know-how make us a well respected business partner. Together with our committed, customer-oriented and unique employees, we are global leaders.

We have developed a broad and deep expert knowledge from many successful projects in a variety of industries. Together with customers we evaluate the best products from the standard range or define project-specific solutions. Thanks to many years of experience and consistent focus on linear motion technology, we have been able to continuously develop our products and solutions and so provide our customers with technical advantages.

State-of-the-art production technologies and highly specialised employees are responsible for the highest possible quality standards. Our production is subject to stringent specifications and tests.

Our high-precision products are suitable for use in a variety of fields of application:

- Biotechnology
- Semiconductor industry
- Laboratory automation
- Medical technology
- Pick and place machines
- Measuring technology
- Micro-automation
- Nanotechnology
- Surface finishing
- Optics industry
- Processing machines for the micro-sector

Our linear guideways and recirculating units are available in many designs, sizes and standard lengths and depending on the specific application can be equipped with balls, rollers or needles.

The use of SCHNEEBERGER linear guideways and recirculating units makes it possible to build cost-effective linear guideway systems. The strengths of our products:

- High level of smoothness and consistent accuracy
- No stick-slip effect
- Rapid travelling speeds
- Minimal wear
- High level of reliability
- High rigidity
- High load carrying capacity
- Used in vacuum and clean room

Our skilled and committed employees will be pleased to advise you at any time on how to develop your applications.

## 2 Useful guidelines

### 2.1 2D- and 3D-drawings

Drawings and models are available on the Cadenas Part Server free of charge in all formats.

The required download area with additional product information can be found on the web site [www.schneeberger.com](http://www.schneeberger.com).

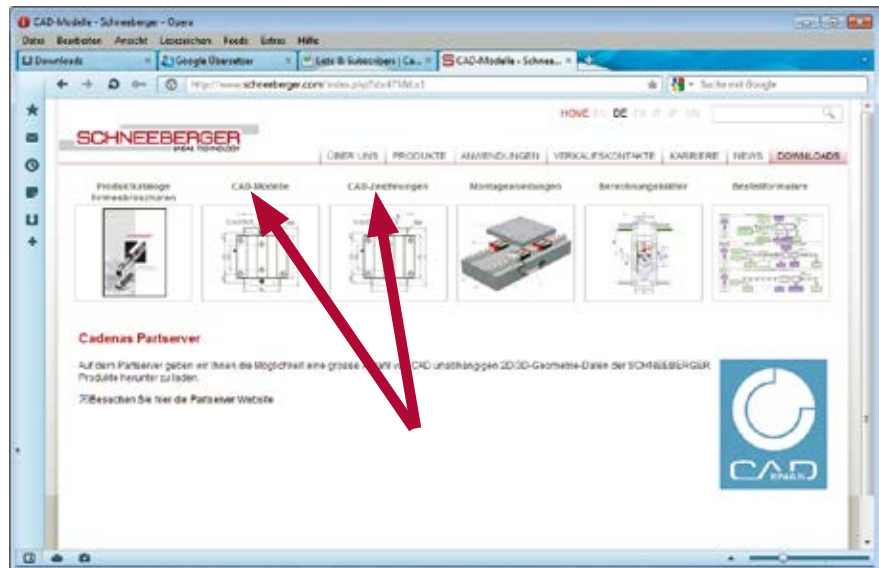

### 2.2 Regulations governing substances and limit values

The products presented in this catalogue do not include any forbidden substances based on the RoHs guidelines and do not release chemical substances in accordance with the REACH guidelines.

## 2 Useful guidelines

### 2.3 Index and type designations

<b>A</b>	<b>Chapter</b>
A rail	3.3
AA-RF	5.1
AC	5.1
Accelerations	5 / 6 / 9.5 / 10.2
Accuracy and accuracy classes	7.1 / 9.2
AK	5.1
Angular error	13.2
Application-specific solutions	3.5
Assembly guidelines	13.9
<b>B</b>	
B rail	3.3
<b>C</b>	
C rail	3.3
Cage	5
Cage length	11.1
Cage control	5.2 / 5.3 / 7.8 / 7.9
Centralised lubricating system	8.2 / 13.7
Chemical substances	2.2
Coating	7.6 / 7.7
Connecting structure	13.1 / 13.2
Cover	13.6
Correction factor	12.3
Corrosion-resistant steel	7.2
Customer-specific design	3.5
<b>D</b>	
Design	11
Design guidelines	13
D hole	7.10
D rail	3.3
Double V-shaped guide	5.1
DR	7.7
Drawings (2D and 3D)	2.1
DRC1	7.7
Dry run	7.7
Dry Runner	7.7
DU	7.6
DURALLOY®	7.6
Dynamically equivalent load	12.3
<b>E</b>	
EAM	5.5
Earlier generations of the product	3.3
EAV	5.5
EE	5.1
Effective load carrying capacity	12.3
EG	7.3
Elastic deformation	12.5
EM	5.5

<b>E</b>	<b>Chapter</b>
Emergency running characteristic	7.6
Enclosed configuration	13.3
End pieces	5
End screws	5
E rail	3.3
EV	5.5
Event probability	12.3
Example calculations	12.4
Examples of use	4
<b>F</b>	
Fastening	13.4
Fastening screws with thin shaft	5.1 / 5.2 / 5.3 / 5.4
Fixing holes	5 / 6 / 7.10 / 9.3
FORMULA-S	5.2 / 5.3 / 7.8
Friction	9.6 / 10.3
<b>G</b>	
GA	5.1 / 5.2
GAN	5.2
GB	5.1
GBN	5.3
GC	5.1
GC-A	5.1
GCN	5.3
GCN-A	5.3
GD	5.1 / 5.2 / 5.4
GDN	5.3
GFN	5.4
GFO	5.4
GH	5.4
GH-A	5.4
G hole	7.10
GP	8.1
GW	5.4
GW-A	5.4
<b>H / I / J</b>	
HA	7.5
Handling	13.8
Hardness	5 / 6
Hardness factor	12.3
Height-matched linear guideways	7.5
Height offset	13.2
Hole types	5 / 6 / 7.10
Stroke	11.1
HW	5.4 / 5.5
Installation methods	13.3
Installation guidelines	13
J/K	3.3

<b>K</b>	<b>Chapter</b>
KBN	5.2 / 5.3
KBS	5.2 / 5.3
KS	5.2 / 5.3 / 7.8
KZST	5.4 / 5.5 / 7.9
<b>L</b>	
Linear guideways ground together	7.4
L/M	3.3
Load carrying capacity	12
Loading capacity	5 / 6 / 12
Locating surface	7.1 / 13.1 / 13.2
Lubrication	12.2 / 13.7
Lubricating stroke	12.2
<b>M</b>	
Matched recirculating units	8.1
Materials	5 / 6
Multi-part linear guideways	7.4
Moment loads	5 / 6
M/V	3.1 / 5.5
<b>N</b>	
N/O	3.1 / 5.4
Normal quality	7.1
NQ	7.1
NRT	3.2 / 6.4
NRV	3.2 / 6.4
Number of rolling elements	11.1
<b>O</b>	
Open configuration	13.3
Operating temperatures	5 / 6 / 9.4 / 10.1
Options	7 / 8
Order descriptions	14
Oscillating motion	12.2
Overrunning cage	5 / 11.1
Overview of products	3
<b>P / Q</b>	
Parallelism tolerances	7.1
Part Server	2.1
Preload	13.5
Preload wedge	6.4
Product specifications	5 / 6
Product overview	3
Quality classes	7.1
<b>R</b>	
Ra value	13.2
RD	3.1 / 5.1
REACH	2.2
Recirculating unit	3.2 / 6 / 11.2
RF	7.2
Rigidity	12.5



<b>R</b>	<b>Chapter</b>
R linear guideway	3.1 / 5.1
RN	3.1 / 5.2
RNG	3.1 / 5.3
RoHS	2.2
Run-ins rounded	7.3
<b>S</b>	
Seal	13.6
Sealing rings	13.7
Service life	12.1 / 12.2 / 12.3 / 13.1
Short stroke	12.2
SHW	5.4 / 5.5
SK	3.2 / 6.1
SKC	3.2 / 6.2
SKD	3.2 / 6.1
Sliding guideway	3.4
Spacings between fixing holes	9.3
Speeds	5 / 6 / 9.5 / 10.2
Special versions	7 / 8
SQ	7.1
SR	3.2 / 6.3
SSQ	7.1
Standard parameter	9 / 10
Storage	13.8
Subsequent lubrication	13.7
Supporting surface	7.1 / 9.2 / 13.2
Surface quality	13.2
<b>T</b>	
Temperatures	5 / 6 / 9.4 / 10.1
Temperature factor	12.3
Tightening torque settings for adjusting screws	13.5
Tightening torque settings for fastening screws	13.4
Tolerance of the supporting surface to the track	9.2
Transport	13.8
<b>U / V / W / X / Z</b>	
Units	2.4
Vacuum suitability	5.1 / 5.2 / 5.3 / 6.2 / 7.6 / 7.7 / 7.8
V hole	7.10
Web site	2.1
Wipers	5.1 / 5.3 / 5.4 / 5.5 / 6.1 / 6.2 / 6.4
W/Z	3.3
ZG	7.4
ZS	8.2

## 2 Useful guidelines

### 2.4 Description of the units

Name	Description	Unit
a	Event probability	Factor
C	Dynamic loading capacity for a 100'000 m travel distance	N
C <sub>0</sub>	Static loading capacity	N
C <sub>100</sub>	Dynamic loading capacity for a 100'000 m travel distance	N
C <sub>50</sub>	Dynamic loading capacity for a 50'000 m travel distance	N
C <sub>eff</sub>	Effective load carrying capacity per rolling element	N
D <sub>w</sub>	Diameter of the rolling element	mm
F	Operating load, load of the linear guideway	N
F <sub>1</sub> ... F <sub>2</sub> ...	Individual loads	N
f <sub>h</sub>	Hardness factor	Factor
f <sub>t</sub>	Temperature factor	Factor
H	Stroke	mm
K	Cage length	mm
K <sub>t</sub>	Load-bearing (cage) length	mm
L	Length	mm
L	Nominal service life	m
L <sub>1</sub> ... L <sub>2</sub> ...	Partial travel distance	mm
M	Moment load longitudinally and laterally	Nm
M <sub>ds</sub>	Tightening torque	Ncm
M <sub>L</sub>	Permissible moment load longitudinally and laterally	Nm
M <sub>o</sub>	Permissible moment load transversely	Nm
P	Dynamically equivalent load	N
P <sub>L</sub>	Dynamically equivalent load longitudinally	N
P <sub>o</sub>	Dynamically equivalent load transversely	N
P <sub>vs</sub>	Infeed force	N
Q	Medium linear guideway distance	mm
R <sub>A</sub>	Number of rolling elements	Item
R <sub>T</sub>	Number of load-bearing rolling elements	Item
R <sub>Tmin</sub>	Correction factor	Factor
t	Cage division	mm
t <sub>2</sub>	Length of the middle section	mm
w	Distance Cage start to the middle of the first rolling element	mm
δS	Deformation of the connecting structure	µm
δA	Deformation of the rolling element including the guide rail	µm

3 Overview of product



Linear guideway type R



Linear guideway type RD



Linear guideway type RN



Linear guideway type RNG



Linear guideway type N/O



Linear guideway type M/V



Recirculating unit type SK



Recirculating unit type SKD



Recirculating unit type SKC



Recirculating unit type SR



Recirculating unit type NRT

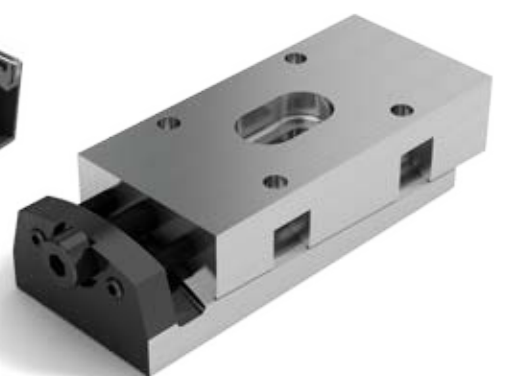

Preload wedge NRV

## 3 Overview of product

### 3.1 An overview of linear guideways

The SCHNEEBERGER range of linear guideways offers you perfect solutions for your specific applications.



	R	RD	RN	RNG	N/O	M/V
For features and dimension table, see chapter	5.1	5.1	5.2	5.3	5.4	5.5

#### Assessment of the advantages

Parameter: displacement force & high level of smoothness

- balls	++++	++++				
- rollers	+++	+++	+++	+++		
- needles					++	++

Parameter: High loading capacity

- balls	+	+				
- rollers	++	++	+++	+++		
- needles					++++	++++

#### Legend:

- ++++ best choice
- +++
- ++
- + good choice

#### Performance parameters

Maximum acceleration in m/s <sup>2</sup>	50	50	50	50	50	50
Maximum acceleration with cage control in m/s <sup>2</sup>	Not available	Not available	300	300	200	200
Maximum speed in m/s	1	1	1	1	1	1
Maximum speed with cage control in m/s	Not available	Not available	1	1	1	1
Quality classes	see chapter 9.1	see chapter 9.1	see chapter 9.1	see chapter 9.1	see chapter 9.1	see chapter 9.1
Operating temperature in degrees Celsius	-40° C – +80° C	-40° C – +80° C	-40° C – +80° C	-40° C – +80° C	-40° C – +80° C	-40° C – +80° C

#### Material (standard)







Rail made of tool steel, hardness in HRC	58 - 62	58 - 62	58 - 62	58 - 62	58 - 62	58 - 62
Rolling element made of tool steel, hardness in HRC	58 - 64	58 - 64	58 - 64	58 - 64	58 - 64	58 - 64

#### Material (corrosion-resistant)

Rail made of tool steel, hardness in HRC	min. 54	min. 54	min. 54	min. 54	min. 54	min. 54
Rolling element made of tool steel, hardness in HRC	min. 56	min. 56	min. 56	min. 56	min. 56	min. 56

### 3 Overview of product

The following special versions do not apply in respect of every rail cross-section or every rail length. For details and technical information, see chapter 7.

Special versions	Order code						
		R	RD	RN	RNG	N/O	M/V
Precision in special quality <sup>(1)</sup>	SQ	✓	✓	✓	✓	✓	✓
Precision in super special quality <sup>(1)</sup>	SSQ	✓	✓	✓	✓	✓	✓
Linear guideways made of corrosion-resistant steel <sup>(2)</sup>	RF	✓	✓	✓	✓	✓	✓
Run-ins rounded	EG	✓	✓	✓	✓	✓	✓
Prepared for roller cage type EE	EE	✓	✓	---	---	---	---
Multi-part linear guideways	ZG	✓	✓	✓	✓	✓	✓
Pair of height-matched guideways	HA	✓	✓	✓	✓	✓	✓
DURALLOY <sup>®</sup> coating <sup>(3)</sup>	DU	✓	✓	✓	✓	✓	✓
DryRunner coating <sup>(4)</sup>	DR	---	---	✓	✓	---	---
Cage control FORMULA-S	KS	---	---	✓	✓	---	---
Cage control	KZST	---	---	---	---	✓	✓
Various versions of fixing holes	V, G, D	✓	✓	✓	✓	✓	✓

(1) There are limitations relating to:

- corrosion-resistant steel
- coatings
- maximum rail length

(2) There are limitations relating to:

- Maximum rail length (in normal quality as well as in options SQ and SSQ)
- Hardness of the steel. This is reduced to a min. 54 HRC, which affects the service life of the linear guideway

(3) - The special versions ZG and SSQ are not possible

- Special quality (SQ) only on request

(4) - DryRunner<sup>®</sup> supports operating without a lubricant. Due to increased cage creep we recommend the additional use of the option «cage control FORMULA-S»

- Options ZG and SSQ cannot be supplied. Option SQ on request
- There are limitations concerning maximum rail length

### 3 Overview of product

#### 3.2 An overview of recirculating units

The SCHNEEBERGER range of recirculating units offers you perfect solutions for your specific applications



	SK	SKD	SKC	SR	NRT
For features and dimension table, see chapter 6	6.1	6.1	6.2	6.3	6.4

Assessment of the advantages

Parameter: Low displacement force & high level of smoothness

	SK	SKD	SKC	SR	NRT
- balls	+++	++++	++++		
- rollers				++	++

Parameter: High loading capacity

	SK	SKD	SKC	SR	NRT
- balls	++	++	+		
- rollers				+++	++++

Legend:

- ++++ best choice
- +++
- ++
- + good choice

Performance parameters

	SK	SKD	SKC	SR	NRT
Max. acceleration in m/s <sup>2</sup>	50	50	50	50	50
Max. speed in m/s	2	2	2	2	1
Operating temperature in degrees Celsius	-40° C – +80° C	-40° C – +80° C	-150° C to +200° C	-40° C – +80° C	-40° C – +80° C

Material (standard)

	SK	SKD	SKC	SR	NRT
Supporting structure of tool steel, hardness in HRC	58 - 62	58 - 62	58 - 62 coated	58 - 62	58 - 62
Rolling element made of tool steel, hardness in HRC	58 - 64	58 - 64 (Damping elements made of plastic)	---	58 - 64	58 - 64
Rolling element made of ceramic (Balls made of Teflon® are situated between the ceramic balls)	---	---	✓	---	---
Redirection unit	Size 1, 2, 9 and 12 made of anodized aluminium Sizes 3 and 6 depending on the length made of plastic or aluminium	Depending on the length made of plastic or aluminium	tool steel, coated	Depending on the length made of plastic or aluminium	Plastic

Special versions

Detailed technical information on the options listed below can be found in chapter 8

	Order code	SK	SKD	SKC	SR	NRT
Matched (height-matched)	GP	✓	✓	✓	✓	✓
Connection for centralised lubrication	ZS	---	---	---	---	✓

### 3 Overview of product

#### 3.3 Earlier generations of the product

Examples of earlier generations of the product, which we are also pleased to manufacture for your today:

Linear guideway type W/Z

Linear guideway type L/M or J/K



Linear guideways type A, B, C, D, E etc.



A



B



C

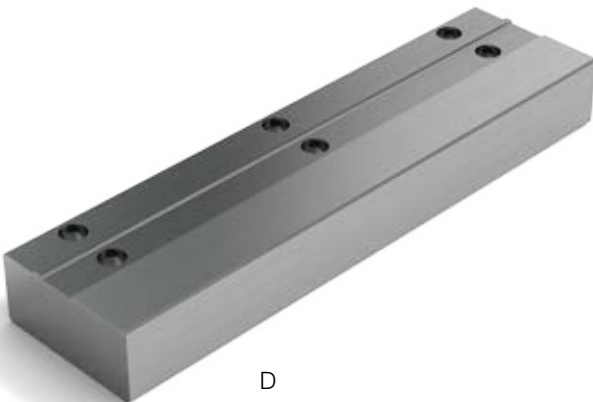

D

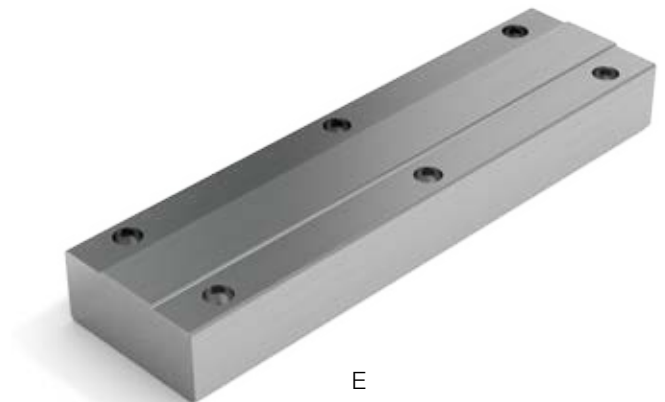

E

## 3 Overview of product

### 3.4 Slideways

In some applications slideways/slide bearings are more suitable than roller-contact bearings. For such applications SCHNEEBERGER produces steel strips, which are stuck with a slideway lining selected by the customer (e.g. Turcite B, Glycodur or Ampco) and then re-ground.

The slideways can be supplied in standardised dimensions for the roller-contact bearing or on a customer-specific basis too.

Slideways

Flat strips

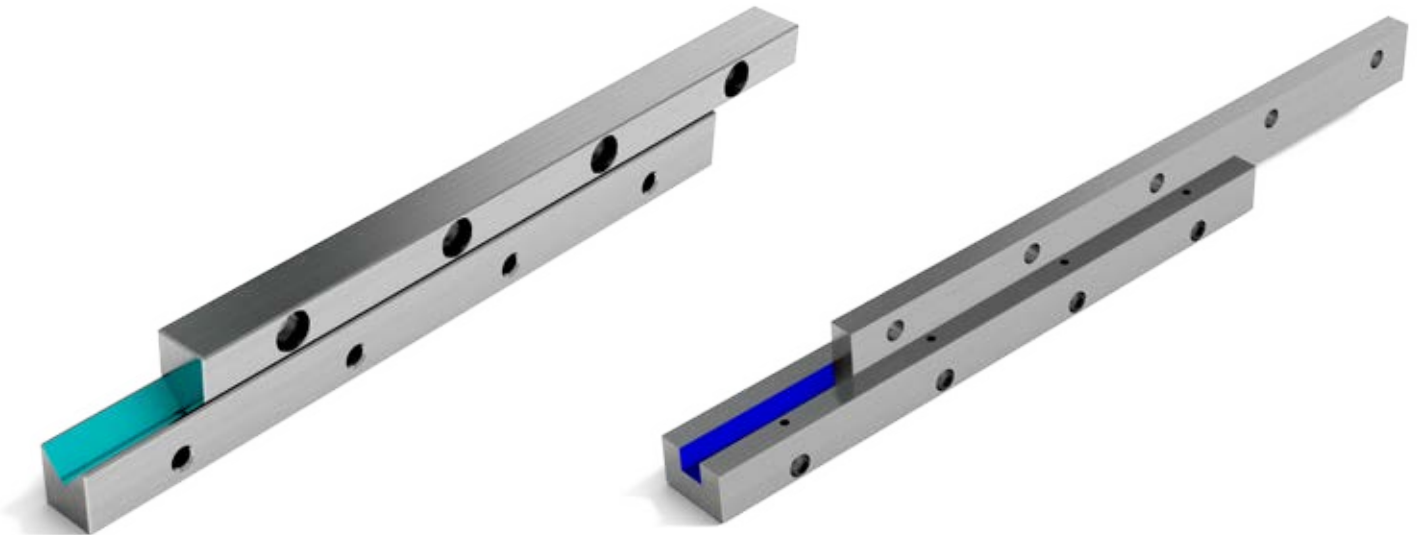

### 3.5 Application-specific solutions

Our linear guideways can be universally deployed, but can also be configured on a customer-specific basis ex works. Amongst other things, SCHNEEBERGER offers the following services:



- modified standard
- customer-specific design
- special greasing (cleanroom, vacuum, extraordinary temperature ranges, etc.)
- special packaging





## 4 Examples of us

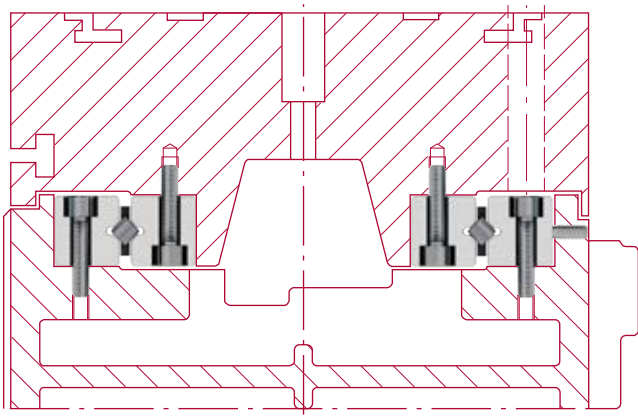

### Linear guideway for a tool grinding machine table

Precision-grinding on tool grinding machines requires a stick-slip-free and frictionless guideway to allow longitudinal movement of the table.

#### Possible SCHNEEBERGER products:

- 4 linear guideways type R 9-800
- 2 roller cages AC 9 x 33 rollers
- 8 end pieces GA 9, GB 9

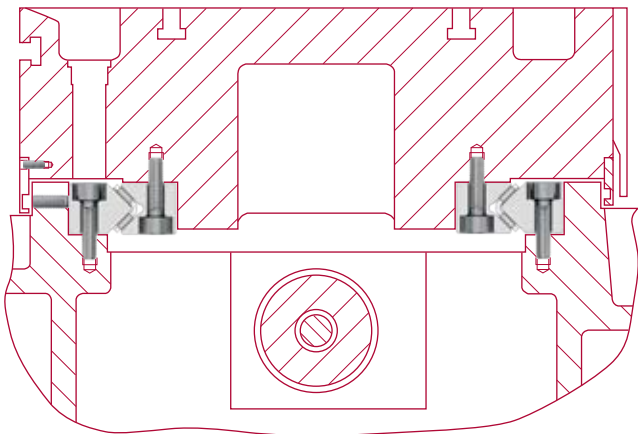

### Table bearing for an internal cylindrical grinding machine

Internal cylindrical grinding robots require absolutely zero-backlash table guiding in order to meet the stringent requirements of today's grinding technology.

The grinding table displayed is mounted with type N/O linear guideways whose V-shaped needle cages are connected to an oil impulse lubrication system. This creates the conditions needed to control high table speeds with minimal force applied.

#### Possible SCHNEEBERGER products:

- 2 linear guideways type O 2535-1000
- 2 linear guideways type N 2535-1000
- 2 needle cages HW 20 x 725
- 4 end pieces GH 2535 without wipers

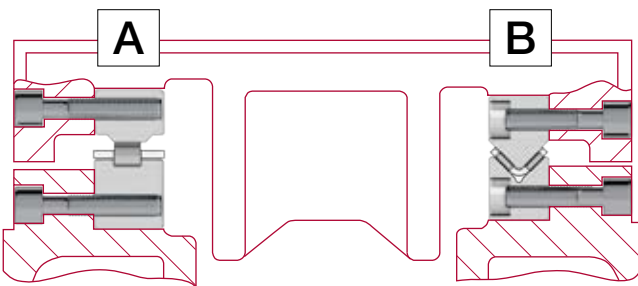

### Open configuration (floating bearings) for heavy surface grinding machine

Surface-mounted roller guides then come into play particularly when large and heavy workpieces are being machined. The weights of table and workpiece and the grinding pressure have a vertical action on the roller guides.

Cost-effectiveness, simple assembly and a high level of running accuracy characterise this configuration. Expansion of the table resulting from the effect of heat without limitations is also prevented thanks to free expansion options.

Its construction is simple and cost-effective. The N/O linear guideway assumes the task of being the lateral linear guideway for the table. As the surface guideway is adjusted level with the N/O, the linear guideway systems can be interchanged - depending on whether the grinding spindle is mounted to the right or left.

#### Possible SCHNEEBERGER products:

- A**
- 1 linear guideway spec. 45 x 35 x 600-EG \*
  - 1 linear guideway spec. 45 x 42.5 x 1'000
  - 1 roller cage H 25 x 810 mm
  - 2 end pieces special

\* Run-ins rounded

- B**
- 1 linear guideway type N 3555-600-EG \*
  - 1 linear guideway type O 3555-1000
  - 1 needle cage SHW 30 x 810 mm
  - 2 end pieces GW 3555

\* Run-ins rounded

## 4 Examples of us

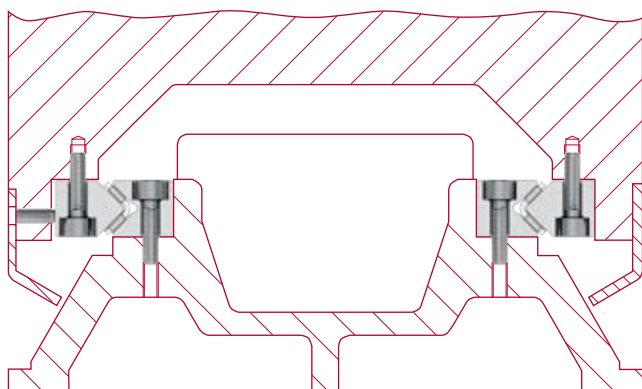

### Possible SCHNEEBERGER products:

- 2 linear guideways N 3045-900
- 2 linear guideways O 3045-900
- 2 needle cages SHW 25 x730 mm
- 8 end pieces GF 3045

### Closed V guideway for surface grinding machines

Economic perspectives also determine the structural design of the tables guideways for surface grinding machines. The V-shaped arrangement of the roller guideways creates a closed linear guideway that can be loaded for forces and moments from all directions.

The few components ensure rapid and simple assembly. The stroke and table length ratios are optimal for the use of roller guideways. The basic surfaces of the roof-shaped linear guideways can be machined with extreme efficiency and precision because they are on the same plane. These surfaces also form the basis for achieving high levels of running accuracy.

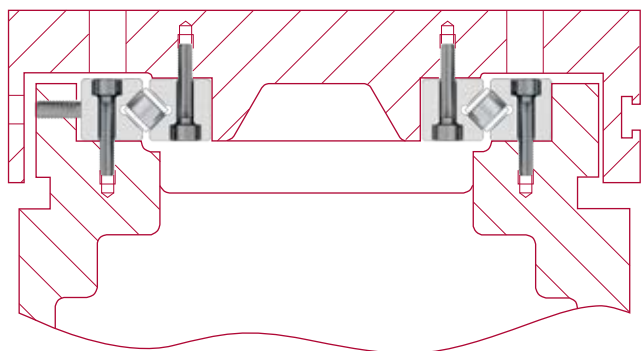

### Possible SCHNEEBERGER products:

- 2 linear guideways RNG 9-700
- 2 linear guideways RNG 9-450-EG \*
- 2 roller cages KBN 9 x 43 rollers
- 4 end pieces GCN 9

\* Run-ins rounded

### V guideway for heavy tool grinding machines

Tool grinding machines place very high demands on the roller guideway system of the machine table. High level of running accuracy, minimal friction, no stick-slip effect and protected arrangement of the roller guideways are the most important requirements.

The RNG roller guideways used here are ideally suited to this task thanks to their high load carrying capacity. The table construction allows drive mechanisms to be accommodated; the upper part of the table can also be installed with great ease. The preload of the linear guideway system can also be easily set subsequently.

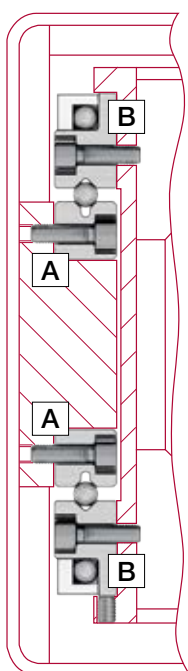

### Infeed device

The infeed device working in vacuum places high demands on the linear guideway system. A U-shaped support forms the supporting element and also acts as the take-up for the linear guideways. The whole system is made of a non-corrosive material and works vertically with a stroke of 2'700 mm.

Linear guideways, which are assembled in the U-shaped basic component, and 4 type SK rolling elements form the actual guide system. Two of the four rolling elements can be adjusted externally and so support optimal preload setting. All individual components of the rolling elements are made out of stainless steel or aluminium.

### Possible SCHNEEBERGER products:

- A** 4 linear guideways R 9-1400-RF \*-ZG \*\*
- B** 4 recirculating units SK 9-150-RF \*

\* non-corrosive  
\*\* multi-part linear guideways

## 4 Examples of us



Source: VARIAN

### Patient tables

Highly developed, automatic patient tables are used, amongst other things, in computer tomography (CT), magnetic resonance tomography (MRT) or radiotherapy.

All kinematic processes place the highest demands on the linear guideway systems in terms of running accuracy, smoothness, maintenance-free operation, rigidity, ease of installation and radiation resistance.

### Possible SCHNEEBERGER products:

R 9 linear guideways



### Microtome

Microtomes are cutting devices used to create wafer-thin sections. They are used for microscopic preparations (for example, biological tissue) or analysis of plastics.

Biological material is normally hardened before being cut by means of fixing and then made sliceable by means of «embedding», i.e. inclusion with a fluid substance such as paraffin or synthetic resin. The thickness of the slices is significantly smaller than the diameter of a human hair and is typically around 1 to 100 µm.

Due to these extraordinary requirements, the most stringent demands in terms of smoothness and precision are placed on the linear guideway systems.

### Possible SCHNEEBERGER products:

RNG 4 linear guideways



Source: LEICA

## 4 Examples of us



Source: KAIJO

### Wire bonder

Wire bonding is the preferred method for making bonds between an integrated circuit (IC) and a printed circuit board. Wire bonding generally represents the most cost-effective and flexible bonding technology with which the thinnest wires are used for bonding electrical connections.

Aluminium, copper or gold wire from 15  $\mu\text{m}$  in diameter is usually used for this technology. The requirements in respect of the linear guideway system for a wire bonder are correspondingly stringent.

- The highest precision and rigidity
- The highest speeds
- The highest level of smoothness
- The highest level of reliability.

### Possible SCHNEEBERGER products:

SCHNEEBERGER supplies prestigious manufacturers of wire bonders with customer-specific linear guideway systems.

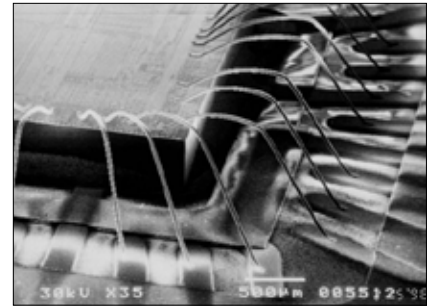

Aluminium wires with a diameter of 25  $\mu\text{m}$  bond the electrodes of microchip with the conductor tracks of a carrier substrate.

Source: University of Paderborn

### Large-scale machining centre

To ensure that it is possible to manufacture with high precision under the most stringent loads, rigid and precise linear guideway systems are critical.

### Possible SCHNEEBERGER products:

- A** MONORAIL MR 65
- B** recirculating unit NRT with preload wedge NRV



Source: VISION WIDE TECH CO.,LTD

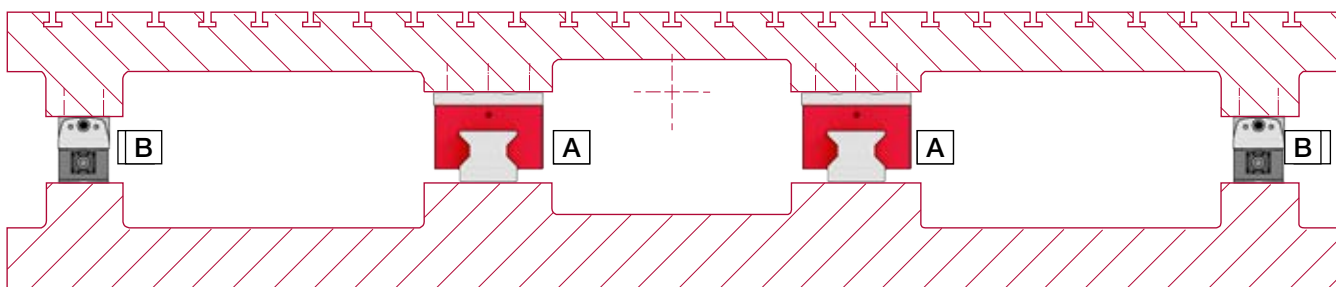

## 5 Product specifications

### 5.1 Type R and RD

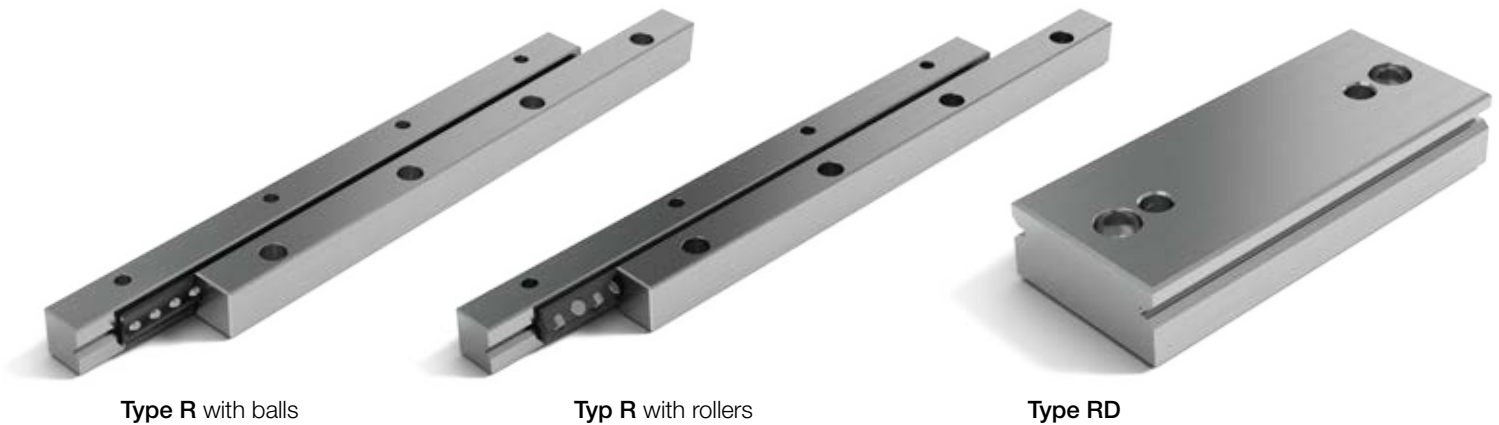

Type R with balls

Typ R with rollers

Type RD

With its type R, SCHNEEBERGER has developed the first standardised cross roller guide, which has defined the global industry standard.

The RD double V-shaped guide supplements the R linear guideway and supports space-saving and cost-effective solutions.

#### Type R benchmark data

Track and surface quality

- Finely ground supporting and/or locating surfaces and tracks (90° V-profile)

Materials (standard)

- Rails from through hardened tool steel 1.2842, hardness 58 - 62 HRC.  
The sizes R/RD 1 and 2 are made out of tool steel 1.3505.
- For non-corrosive guideways tool steel 1.4034 is used.
- Rolling element made of through hardened roller bearing steel, hardness 58 - 64 HRC.

Rolling element

- Ball or roller

Speed

- 1 m/s

Acceleration

- 50 m/s<sup>2</sup>

Accuracy

- R and RD linear guideways are available in three quality classes (see chapter 9)

Operating temperatures

- -40° C to +80° C

The R and RD design can be combined with the following products:

- recirculating unit type SK, SKC and SR

## 5 Linear guideways

### Dimensions and load capacities type R

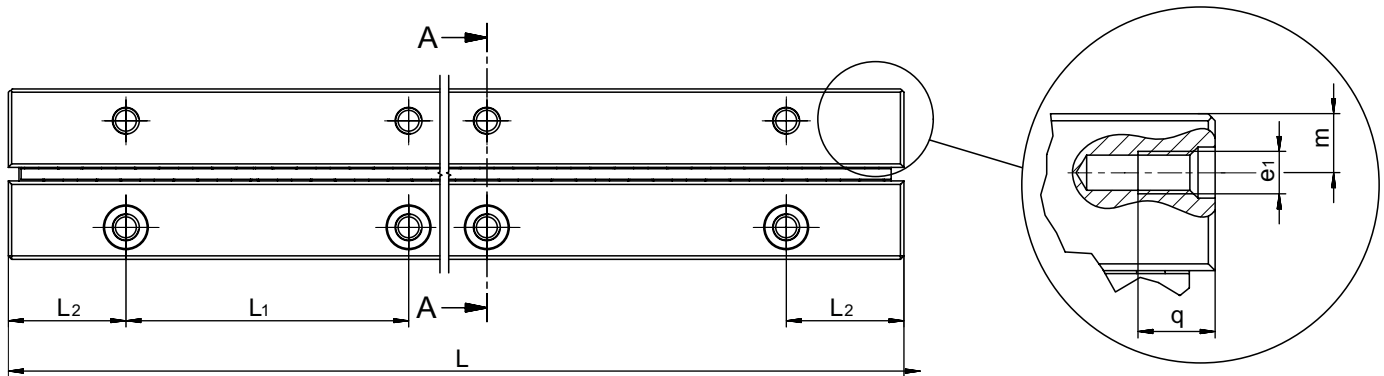

Type	Size	L in mm	Weight in g	A	B	Dw	J	L <sub>1</sub>	L <sub>2</sub>	N	d	e	e <sub>1</sub>	f	g	m	q	Options (see chapter 7)	Accessories
				mm															
R	1	20	3	8.5	4	1.5	3.9	10	5	1.8	3	M2	M1.7	1.65	2.6	1.9	2.5	SQ SSQ RF EG ZG HA DU	Cage: - AA-RF 1 - AC 1 - AK 1  End piece: - GB 1
		30	4																
		40	5																
		50	6																
		60	7																
		70	8																
		80	9																
		100	12																
120	14																		
R	2	30	8	12	6	2	5.5	15	7.5	2.5	4.4	M3	M2.5	2.55	4	2.7	3.5	SQ SSQ RF EG ZG HA DU	Cage: - AA-RF 2 - AC 2 - AK 2  End piece: - GB 2
		45	11																
		60	14																
		75	17																
		90	20																
		105	23																
		120	26																
		150	34																
180	40																		
R	3	50	23	18	8	3	8.3	25	12.5	3.5	6	M4	M3	3.3	4.8	4.1	7	SQ SSQ RF EG ZG HA DU	Cage: - AA-RF 3 - AC 3 - AK 3 End pieces: - GB 3 - GC 3 - GC-A 3 End screw: - GA 3 Fastening screw - GD 6
		75	34																
		100	45																
		125	56																
		150	67																
		175	78																
		200	89																
		225	100																
		250	111																
		275	122																
		300	133																
		350	156																
		400	178																
500	222																		
600	267																		

**5** Linear guideways

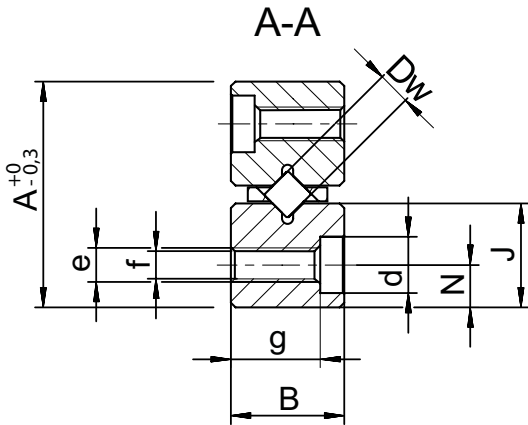

Type	Size	L in mm	Weight in g	A	B	Dw	J	L <sub>1</sub>	L <sub>2</sub>	N	d	e	e <sub>1</sub>	f	g	m	q	Options (see chapter 7)	Accessories
				mm															
<b>R</b>	<b>6</b>	100	145	31	15	6	13.9	50	25	6	9.5	M6	M5	5.2	9.8	6.9	9	SQ SSQ RF EG EE ZG HA DU	Cage: - AA-RF 6 - AC 6 - AK 6 - EE 6 End pieces - GB 6 - GC 6 - GC-A 6 End screw: - GA 6 Fastening screw - GD 6
		150	220																
		200	295																
		250	370																
		300	445																
		350	520																
		400	595																
		450	670																
		500	745																
		600	895																
		700	1'045																
800	1'195																		
1'000	1'500																		
<b>R</b>	<b>9</b>	200	630	44	22	9	19.7	100	50	9	10.5	M8	M6	6.8	15.8	9.8	9	SQ SSQ RF EG EE ZG HA DU	Cage: - AC 9 - AK 9 - EE 9 End pieces - GB 9 - GC 9 - GC-A 9 End screw: - GA 9 Fastening screw - GD 9
		300	945																
		400	1'260																
		500	1'575																
		600	1'890																
		700	2'205																
		800	2'520																
		900	2'835																
		1'000	3'150																
		1'100	3'465																
		1'200	3'780																
1'400	4'410																		
<b>R</b>	<b>12</b>	200	1'040	58	28	12	25.9	100	50	12	13.5	M10	M8	8.5	19.8	12.9	12	SQ SSQ RF EG ZG HA DU	Cage: - AC 12 - AK 12 End pieces: - GB 12 - GC 12 - GC-A 12 End screw: - GA 12 Fastening screw: - GD 12
		300	1'560																
		400	2'090																
		500	2'615																
		600	3'140																
		700	3'665																
		800	4'190																
		900	4'715																
		1'000	5'240																
		1'100	5'765																
		1'200	6'290																

The types in bold are standard. Other lengths and types R 15, R 18 and R 24 are available on request



## 5 Linear guideways

### Dimensions and load capacities of type RD

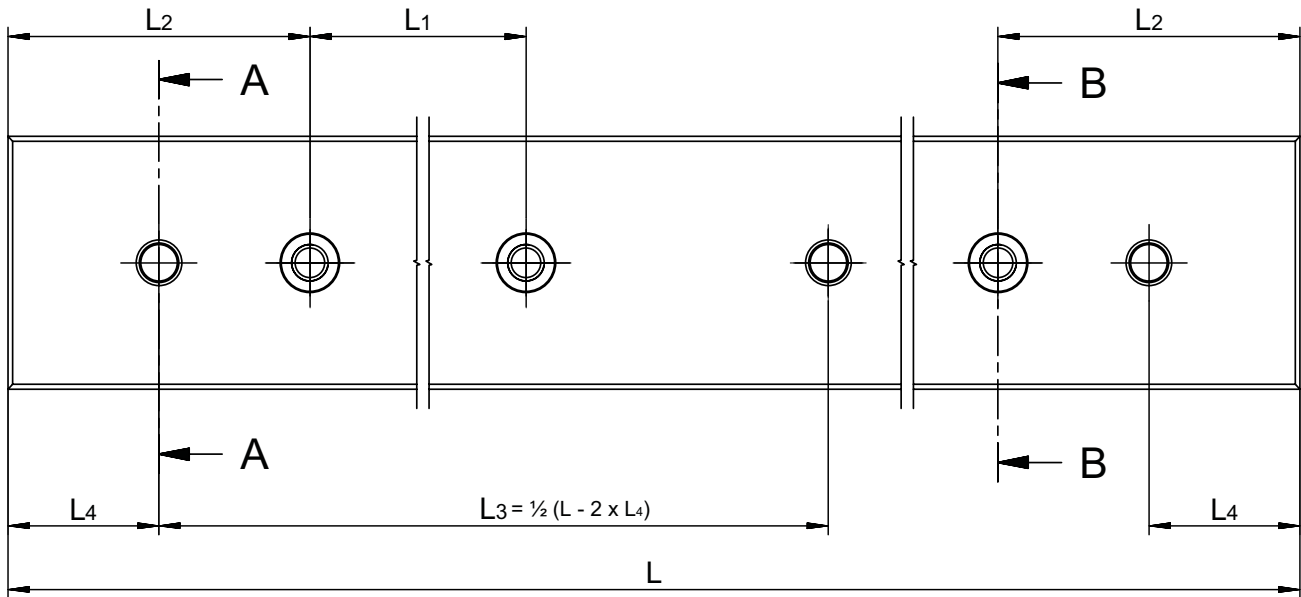

Type	Size	L in mm	Weight in g	A	B	B <sub>1</sub>	B <sub>2</sub>	Dw	J	L <sub>1</sub>	L <sub>2</sub>	L <sub>4</sub>	Q	d	d <sub>1</sub>	e	f	f <sub>1</sub>	g	g <sub>1</sub>	k	Options (see chapter 7)	Accessories
				mm																			
RD	1	100	50	22	4	5.5	6	1.5	12.8	25	12.5	5	13.5	4.4	-	M3	2.55	3 H7	3.5	-	2	SQ SSQ RF EG ZG DU	Cage: - AA-RF 1 - AC 1 - AK 1
		150	70																				
		200	100																				
RD	2	200	220	30	6	8.5	9	2	17	50	25	12.5	18	6	-	M4	3.35	3 H7	5.4	-	3	SQ SSQ RF EG ZG DU	Cage: - AA-RF 2 - AC 2 - AK 2
		300	320																				
		400	430																				
RD	3	300	690	46	8	11.5	12	3	26.6	50	25	12.5	28	7.5	3.5	M5	4.2	3 H7	7.3	6.5	4	SQ SSQ RF EG ZG DU	Cage: - AA-RF 3 - AC 3 - AK 3
		400	920																				
		500	1'150																				
		600	1'380																				
		800	1'840																				

**5** Linear guideways

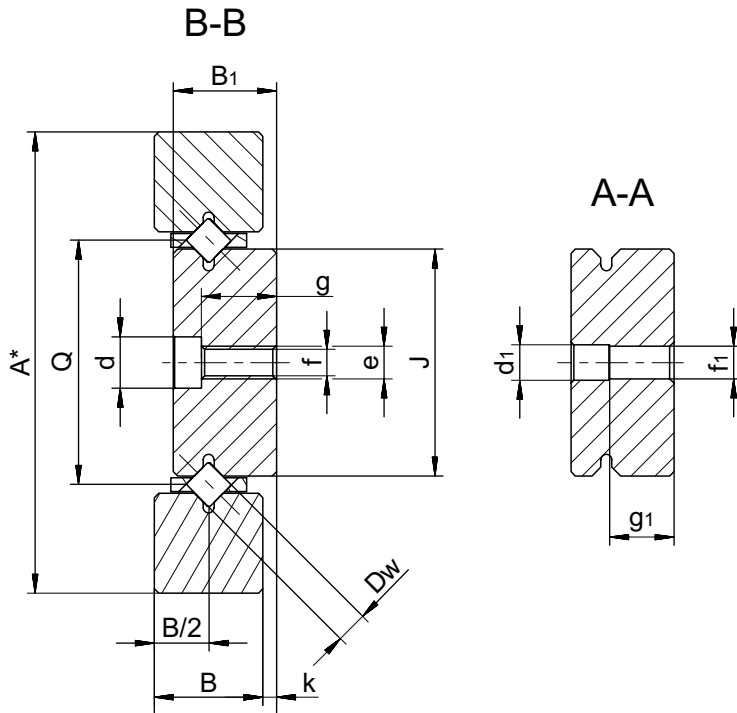

\* with linear guideways type R

Type	Size	L in mm	Weight in g	A	B	B <sub>1</sub>	B <sub>2</sub>	Dw	J	L <sub>1</sub>	L <sub>2</sub>	L <sub>4</sub>	Q	d	d <sub>1</sub>	e	f	f <sub>1</sub>	g	g <sub>1</sub>	k	Options (see chapter 7)	Accessories
				mm																			
RD	<b>6</b>	Max. 2000	On request	76	15	19	20	6	41.8	100	50	25	45	9.5	6.5	M6	5.2	6 H7	13.8	12	5	SQ SSQ RF EG EE ZG DU	Cage: - AA-RF 6 - AC 6 - AK 6 - EE 6
RD	<b>9</b>	Max. 2000	On request	116	22	27	28	9	67.4	100	50	25	72	10.5	8.5	M8	6.8	8 H7	20.8	16	6	SQ SSQ RF EG EE ZG DU	Cage: - AC 9 - AK 9 - EE 9
RD	<b>12</b>	Max. 2000	On request	135	28	34	35	12	70.8	100	50	25	77	13.5	10.5	M10	8.5	10 H7	25.8	20	7	SQ SSQ RF EG ZG DU	Cage: - AC 12 - AK 12

The types in bold are standard. Other lengths and types RD 6, RD 9 and RD 12 are available on request

## 5 Linear guideways

### Maximum lengths for type R

Type / Size	Quality class	Max. lengths in standard material (in mm)	Max lengths in non-corrosive material (in mm)
R 1	NQ	180	150
	SQ		
	SSQ	120	120
R 2	NQ	300	300
	SQ	300	300
	SSQ	180	180
R 3	NQ	700	600
	SQ		
	SSQ	600	
R 6	NQ	1500	1400
	SQ		1200
	SSQ	1200	900
R 9	NQ	1500	1400
	SQ		1200
	SSQ	1200	900
R 12	NQ	1500	1400
	SQ		1200
	SSQ	1200	900

### Maximum lengths for type RD

Type / Size	Quality class	Max. lengths in standard material (in mm)	Max lengths in non-corrosive material (in mm)
RD 1	NQ	300	300
	SQ		
	SSQ		
RD 2	NQ	500	500
	SQ		
	SSQ		
RD 3	NQ	1200	600
	SQ		
	SSQ		
RD 6	NQ	1500	900
	SQ		
	SSQ	1200	
RD 9	NQ	1500	900
	SQ		
	SSQ	1200	
RD 12	NQ	1500	900
	SQ		
	SSQ	1200	

### Rail chamfer

The detail of the rail chamfer is shown in the chart below. Please note that the part number and company logo are marked opposite to the datum and supporting surfaces.

Type / Size	Rail chamfer of reference edges in mm
R 1	0.3 x 45°
R 2	0.3 x 45°
R 3	0.6 x 45°
R 6	0.8 x 45°
R 9	0.8 x 45°
R 12	1.0 x 45°

## 5 Linear guideways

### Accessories for type R and RD

#### Roller cage type AC

**Compatible with:**

Linear guideway type R and RD,  
Sizes 1 to 12

**Design:**

Rollers fixed in place

**Installation method:**

For normal application and certain  
overrunning cage applications

**Material:**

Sizes 1, 2 and 3 POM  
As from size 65 PA GF 30%, plastic/  
steel wire composite construction. The  
wire is made out of stainless steel.

**Option:**

Corrosion-resistant rollers

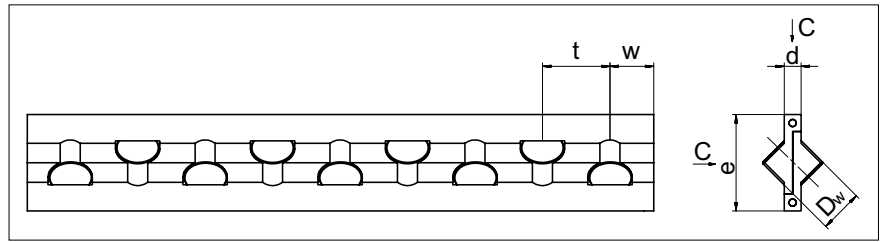

Type	Size	Dw	d	e	t	w	C per roller in N	max. length in mm
AC	1	1.5	0.45	3.5	3	approx. 1.5	50	80
	2	2	0.75	5	4	approx. 2	85	170
	3	3	1	7	5	approx. 2.5	130	1'200
	6	6	2.5	14	9	approx. 6	530	1'500
	9	9	3.5	20	14	approx. 9	1'300	1'500
	12	12	4.5	25	18	approx. 11	2'500	1'500

#### Roller cage type AA-RF

**Compatible with:**

Linear guideway type R and RD,  
Sizes 1, 2, 3 and 6

**Design:**

Rollers fixed in place

**Installation method:**

Not suitable as an overrunning cage

**Material:**

Cage and rollers made of corrosion-re-  
sistant steel and thus also suitable for  
use in vacuum

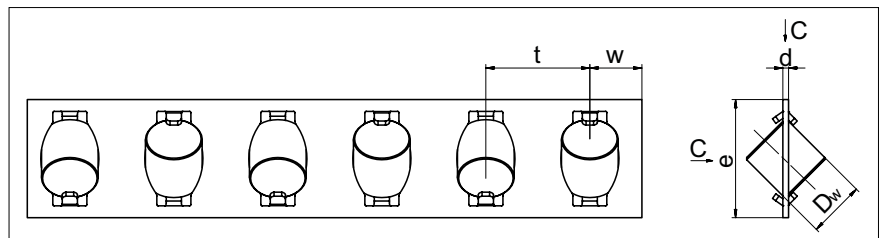

Type	Size	Dw	d	e	t	w	C* per roller in N	max. length in mm
AA-RF	1	1.5	0.2	3.8	3	approx. 1.5	44	90
	2	2	0.25	5.9	4	approx. 2	75	150
	3	3	0.3	7.5	5	approx. 2.5	115	350
	6	6	0.8	14	12	approx. 6	465	1'200

\*The loading capacity C already includes the hardness factor  $f_H$  as set out in  
chapter 12.3

## 5 Linear guideways

### Accessories for type R and RD

#### Ball cage type AK

##### Compatible with:

Linear guideway type R and RD,  
Sizes 1 to 12

##### Design:

Balls retained

##### Installation method:

For normal application and certain  
overrunning cage applications

##### Material:

Sizes 1, 2 and 3 POM

As from size 65 PA GF 30%, plastic/  
steel wire composite construction. The  
wire is made out of stainless steel.

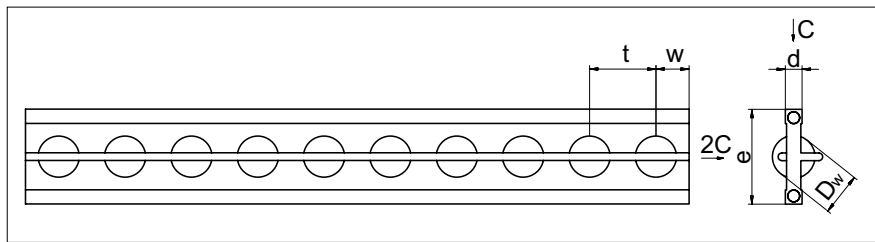

Type	Size	Dw	d	e	t	w	C per roller in N	max. length in mm
AK	1	1.5	0.45	3.5	2.2	approx. 1.5	9	80
	2	2	0.75	5	4	approx. 2	15	100
	3	3	1	7	4.2	approx. 2.5	25	180
	6	6	2.5	14	9	approx. 6	65	1'500
	9	9	3.5	20	14	approx. 9	150	1'500
	12	12	4.5	25	18	approx. 11	260	1'500

#### Roller cage type EE

##### Compatible with:

Linear guideway type R and RD,  
Sizes 6 and 9

##### Design:

- The clearances of the guide rails are matched with the EE roller cage, which consequently works as a dirt wiper. Displacement resistance is increased by the wiper function.
- Rollers fixed in place
- Only used with linear guideways with add-on designation EE
- Select end pieces of type GB or GC

##### Installation method:

Not suitable as an overrunning cage and  
for freely surface-mounted guideways

##### Material:

PE

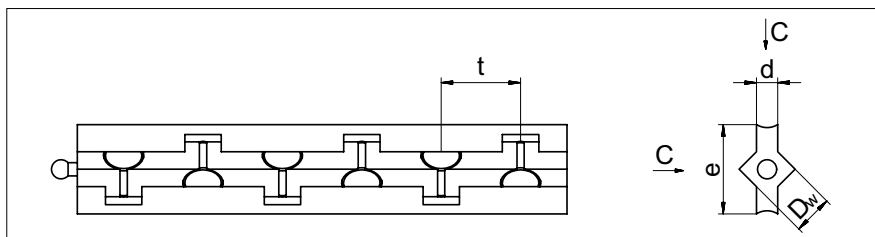

Type	Size	Dw	d	e	t	C per roller in N	max. length in mm
EE	6	6	3.2	13.5	12	530	1'500
	9	9	4.6	19	18	1'300	1'500

## 5 Linear guideways

### Accessories for type R and RD

#### End screws type GA

**Compatible with:**  
Linear guideway R 3 to R 12

**Installation method:**  
For horizontal installation

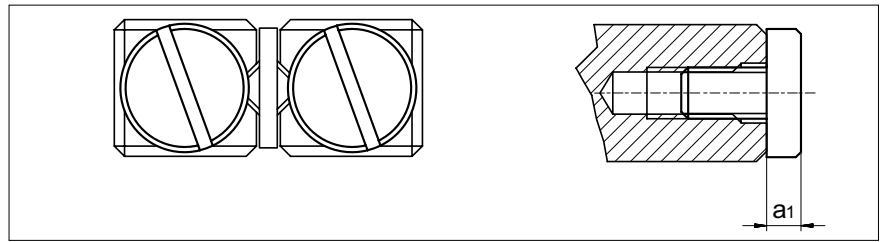

Size	GA 1	GA 2	GA 3	GA 6	GA 9	GA 12
$a_1$	1.2	1.6	2	3	3	3

#### End piece type GB 1

**Compatible with:**  
Linear guideway R 1

**Installation method:**  
No restrictions

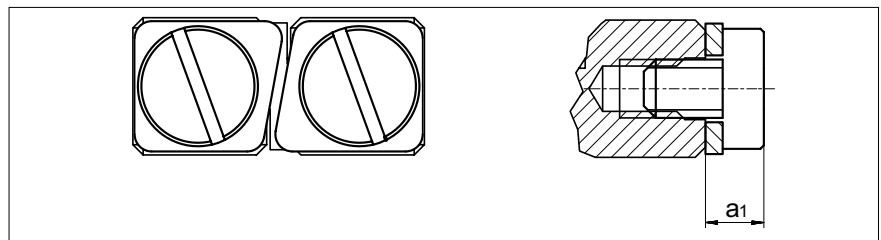

Size	GB 1
$a_1$	1.7

#### End piece type GB 2

**Compatible with:**  
Linear guideway R 2

**Installation method:**  
No restrictions

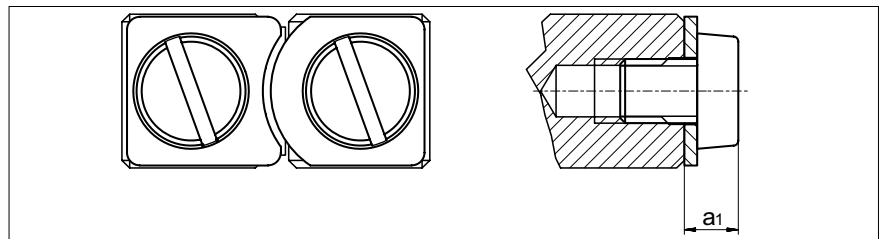

Size	GB 2
$a_1$	2

#### End piece type GB 3 to 12

**Compatible with:**  
Linear guideway R 3 to R 12

**Installation method:**  
No restrictions

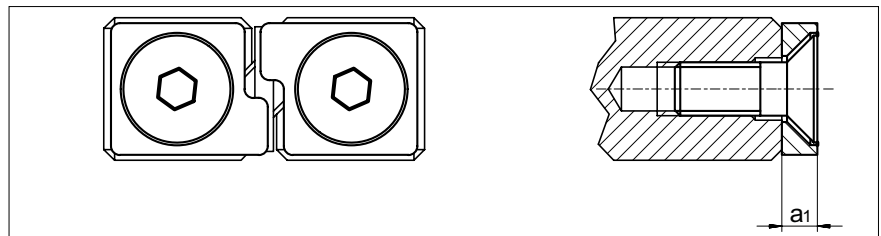

Size	GB 3	GB 6	GB 9	GB 12
$a_1$	2	3	4	5

**Scope of supply:**  
Including fastening screws

## 5 Linear guideways

### Accessories for type R and RD

#### End piece type GC

**Compatible with:**

Linear guideway R 3 to R 12

**Installation method:**

For overrunning cages

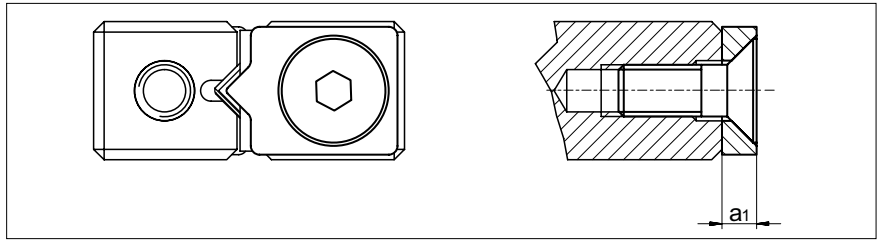

Size	GC 3	GC 6	GC 9	GC 12
$a_1$	2	3	4	5

**Scope of supply:**

Including fastening screws

#### End piece type GC-A (with wipers)

**Compatible with:**

Linear guideway R 3 to R 12

**Design:**

with felt wiper

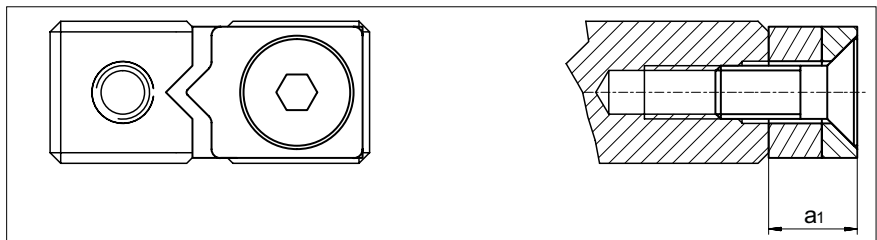

Size	GC-A 3	GC-A 6	GC-A 9	GC-A 12
$a_1$	5	6	7	8

**Installation method:**

No restrictions

**Scope of supply:**

Including fastening screws

#### Fastening screws with thin shaft type GD 3 to GD 12

**Special feature:**

To even out differences in the hold spacings

**Compatible with:**

Linear guideway type R 3 to R 12

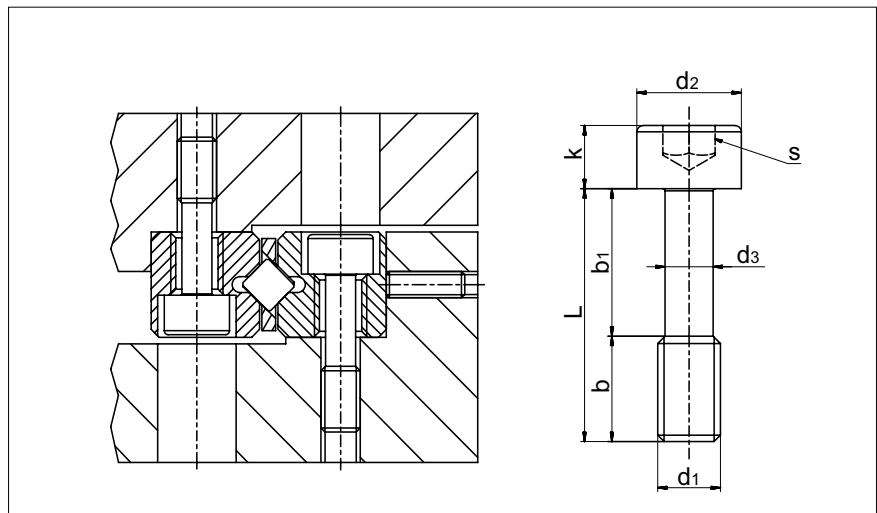

Type	Size	L	b	$b_1$	$d_1$	$d_2$	$d_3$	k	s	Tightening torque in Ncm
GD	3	12	5	7	M3	5	2.3	3	2.5	102
	6	20	8	12	M5	8	3.9	5	4	460
	9	30	12	18	M6	8.5	4.6	6	5	792
	12	40	17	23	M8	11.3	6.25	8	6	1'920

## 5 Linear guideways

### 5.2 Type RN



#### Type RN

The type RN linear guideway is the logical optimised version of the R guideway. It has identical installed dimensions, but due to the larger contact surfaces of the guideway tracks is, however, higher performing. The reduced gap width between the guide rails also provides better protection against dirt.

#### Benchmark data

Track and surface quality

- Finely ground supporting and/or locating surfaces and tracks (90° V-profile)

Materials (standard)

- Rails made of through hardened tool steel 1.2842, hardness 58 - 62 HRC
- For non-corrosive guideways tool steel 1.4034 is used.
- Rolling element made of through hardened roller bearing steel, hardness 58 - 64 HRC.

Rolling element

- Roller

Speed

- 1 m/s
- 1 m/s with cage control

Acceleration

- 50 m/s<sup>2</sup>
- 300 m/s<sup>2</sup> with cage control

Accuracy

- RN linear guideways are available in three quality classes (see chapter 9)

Operating temperatures

- -40° C to +80° C



## 5 Linear guideways

### Dimensions and load capacities of type RN

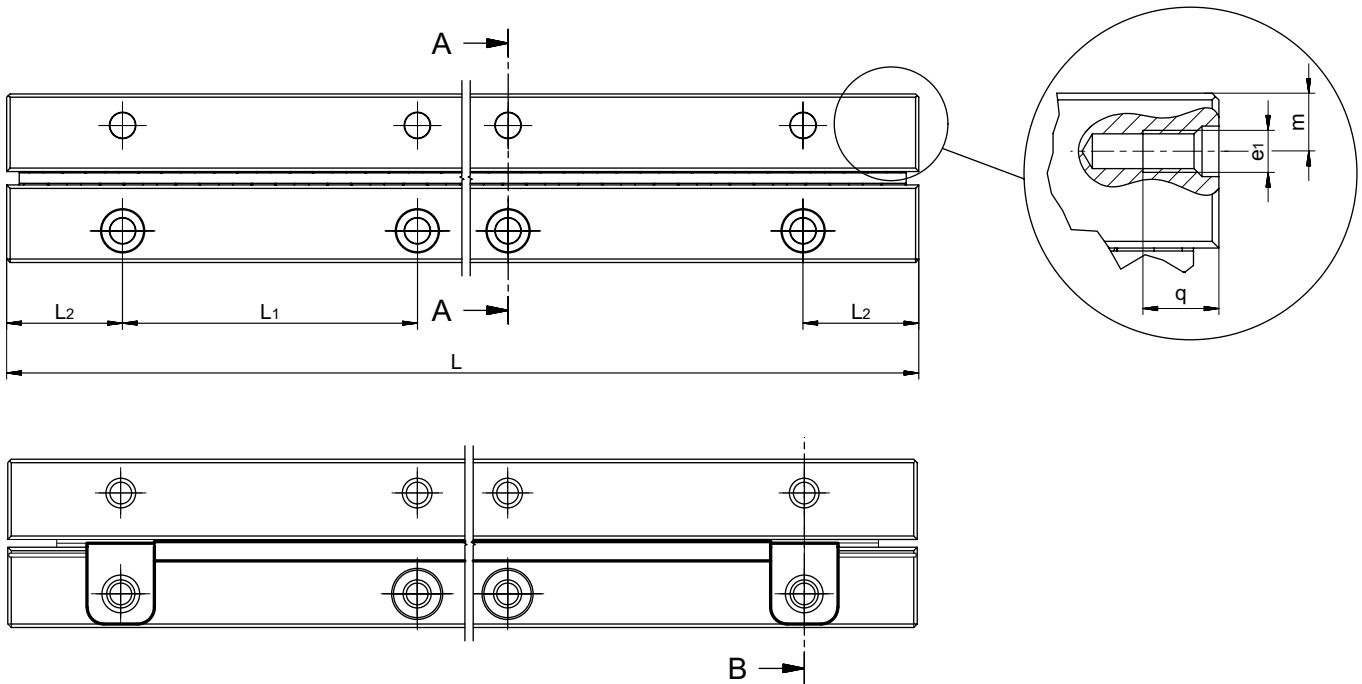

Type	Size	L in mm	Weight in g	A	B	Dw	J	L <sub>1</sub>	L <sub>2</sub>	N	d	e	e <sub>1</sub>	f	g	m	q	s	Options (see chapter 7)	Accessories
				mm																
RN	3	50	24	18	8	3	8.7	25	12.5	3.5	6	M4	M3	3.3	4.8	4.8	7	0.85	SQ	Cage: - KBN 3 - KBS 3 End screw: - GAN 3 Fastening screw: - GD 3
		75	35																	
		100	47																	
		125	59																	
		150	71																	
		175	82																	
		200	94																	
		225	106																	
		250	118																	
		275	129																	
300	141																			
RN	4	80	62	22	11	4.5	10.5	40	20	4.5	8	M5	M3	4.3	6.9	5.5	7	0.85	SQ	Cage: - KBN 4 - KBS 4 End screw: - GAN 4 Fastening screw: - GD 4
		120	93																	
		160	124																	
		200	155																	
		240	186																	
		280	217																	
		320	248																	
		360	279																	
		400	310																	
RN	6	100	151	31	15	6.5	14.8	50	25	6	9.5	M6	M5	5.2	9.8	7.5	9	0.85	SQ	Cage: - KBN 6 - KBS 6 End screw: - GA 6 Fastening screw: - GD 6
		150	226																	
		200	301																	
		250	377																	
		300	452																	
		350	527																	
		400	603																	
		450	678																	
500	753																			

**5** Linear guideways

A-A

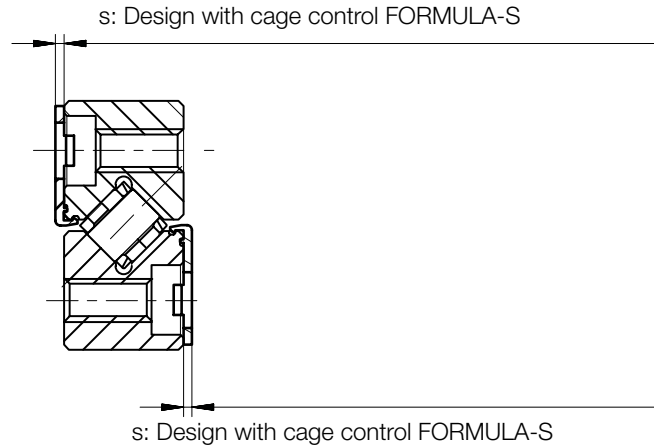
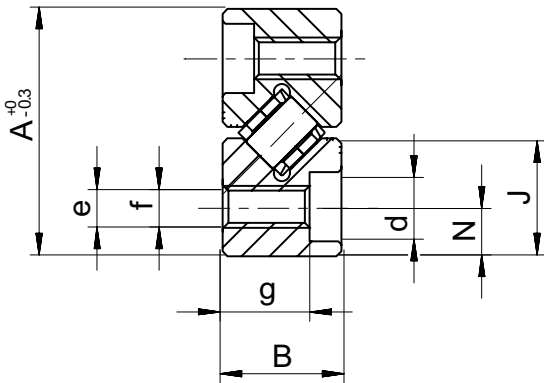

Type	Size	L in mm	Weight in g	A	B	Dw	J	L <sub>1</sub>	L <sub>2</sub>	N	d	e	e <sub>1</sub>	f	g	m	q	s	Options (see chapter 7)	Accessories
				mm																
<b>RN</b>	<b>9</b>	200	659	44	22	9	21.1	100	50	9	10.5	M8	M6	6.8	15.8	11.5	9	-	SQ SSQ RF EG ZG HA DU	Cage: - KBN 9  End screw: - GA 9  Fastening screw: - GD 9
		300	988																	
		400	1'318																	
		500	1'647																	
		600	1'976																	
		700	2'306																	
800	2'635																			
<b>RN</b>	<b>12</b>	200	1'086	58	28	12	27.6	100	50	12	13.5	M10	M8	8.5	19.8	15	12	-	SQ SSQ RF EG ZG HA DU	Cage: - KBN 12  End screw: - GA 12  Fastening screw: - GD 12
		300	1'628																	
		400	2'171																	
		500	2'714																	
		600	3'257																	
		700	3'800																	
		800	4'342																	
		900	4'885																	
1'000	5'428																			

The types in bold are standard. Other lengths and types RN 15, RN 18 and RN 24 are available on request

## 5 Linear guideways

### Maximum lengths for type RN

Type / Size	Quality class	Max. lengths in standard material (in mm)	Max lengths in non-corrosive material (in mm)
RN 3	NQ	700	600
	SQ		
	SSQ	600	
RN 4	NQ	900	900
	SQ	600	600
	SSQ		
RN 6	NQ	1'500	1'400
	SQ		1'200
	SSQ	1'200	900
RN 9	NQ	1'500	1'400
	SQ		1'200
	SSQ	1'200	900
RN 12	NQ	1'500	1'400
	SQ		1'200
	SSQ	1'200	900

### Rail chamfer

The detail of the rail chamfer is shown in the chart below. Please note that the part number and company logo are marked opposite to the datum and supporting surfaces.

Type / Size	Rail chamfer of reference edges in mm
RN 3	0.6 x 45°
RN 4	0.6 x 45°
RN 6	0.8 x 45°
RN 9	0.8 x 45°
RN 12	1.0 x 45°

## 5 Linear guideways

### Accessories for type RN

#### Roller cage type KBN

**Compatible with:**

Linear guideway type RN

Sizes 3 to 12

**Design:**

Rollers fixed in place

**Installation method:**

For normal application and certain overrunning cage applications

**Material:**

POM (Vacuum-compatible up to  $10^{-7}$  mbar)

**Option:**

Corrosion-resistant rollers

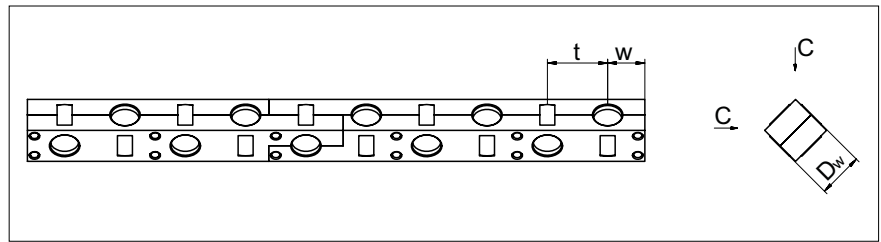

Type	Size	Dw	t	w	C per roller in N	Max. length in mm
KBN	3	3	5	approx. 3.5	410	900
	4	4.5	6.5	approx. 4	850	900
	6	6.5	8.5	approx. 5	1'800	1'500
	9	9	12	approx. 7.5	3'900	1'500
	12	12	15	approx. 9	6'500	1'500

#### Type KBS roller cage for the cage control FORMULA-S

Detailed information on

FORMULA-S is listed under chapter 7.8.

**Compatible with:**

Linear guideway type RN

Sizes 3 to 6

**Design:**

Rollers fixed in place

With integral pinion

**Installation method:**

For normal application and certain overrunning cage applications

**Material:**

POM (Vacuum-compatible up to  $10^{-7}$  mbar)

**Option:**

Corrosion-resistant rollers

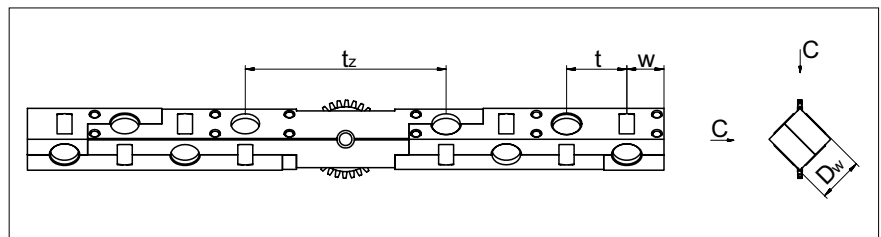

Type	Size	Dw	t	tz	w	C per roller in N	Max. length in mm
KBS	3	3	5	18	approx. 3.5	410	900
	4	4.5	6.5	23	approx. 4	850	900
	6	6.5	8.5	27	approx. 5	1'800	1'500

## 5 Linear guideways

### Accessories for type RN

#### End screws type GAN

**Compatible with:**

Linear guideway RN 3 and RN 4

**Installation method:**

For horizontal installation

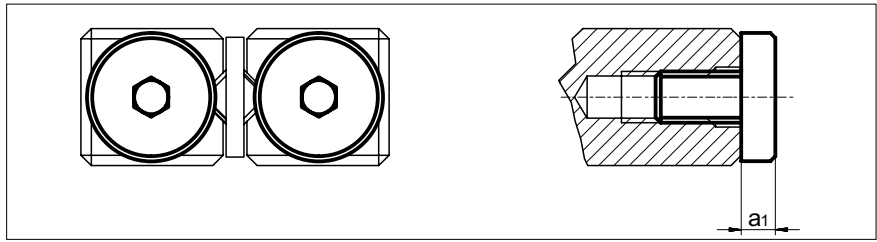

Size	GAN 3	GAN 4
$a_1$	2	2

#### End screws type GA

**Compatible with:**

Linear guideway RN 6 to RN 12

**Installation method:**

For horizontal installation

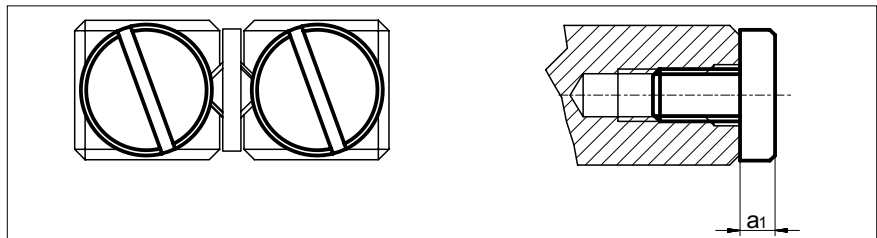

Size	GA 6	GA 9	GA 12
$a_1$	3	3	3

#### Fastening screws with thin shaft type GD 3 to GD 12

**Special feature:**

To even out differences in the hold spacings

**Compatible with:**

Linear guideway type RN 3 to RN 12

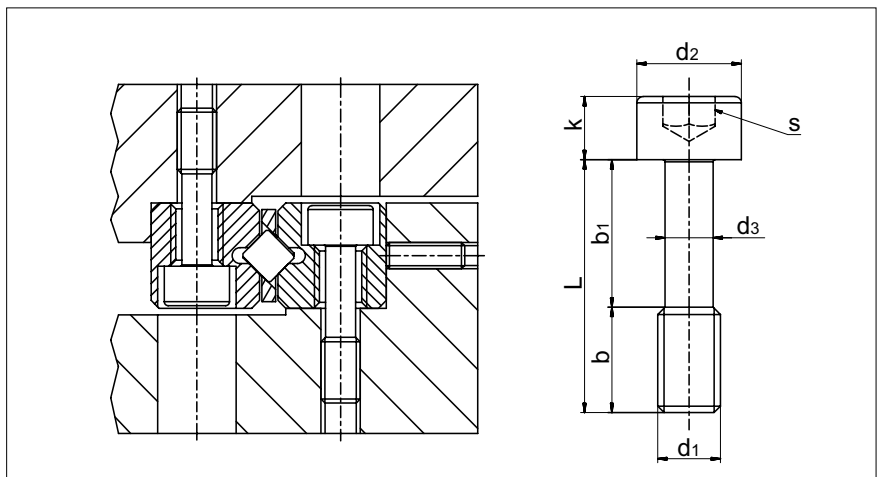

Type	Size	L	b	$b_1$	$d_1$	$d_2$	$d_3$	k	s	Tightening torque in Ncm
GD	3	12	5	7	M3	5	2.3	3	2.5	102
	4	16	7	9	M4	6.5	3	4	3	232
	6	20	8	12	M5	8	3.9	5	4	460
	9	30	12	18	M6	8.5	4.6	6	5	792
	12	40	17	23	M8	11.3	6.25	8	6	1'920

## 5 Linear guideways

### 5.3 Type RNG

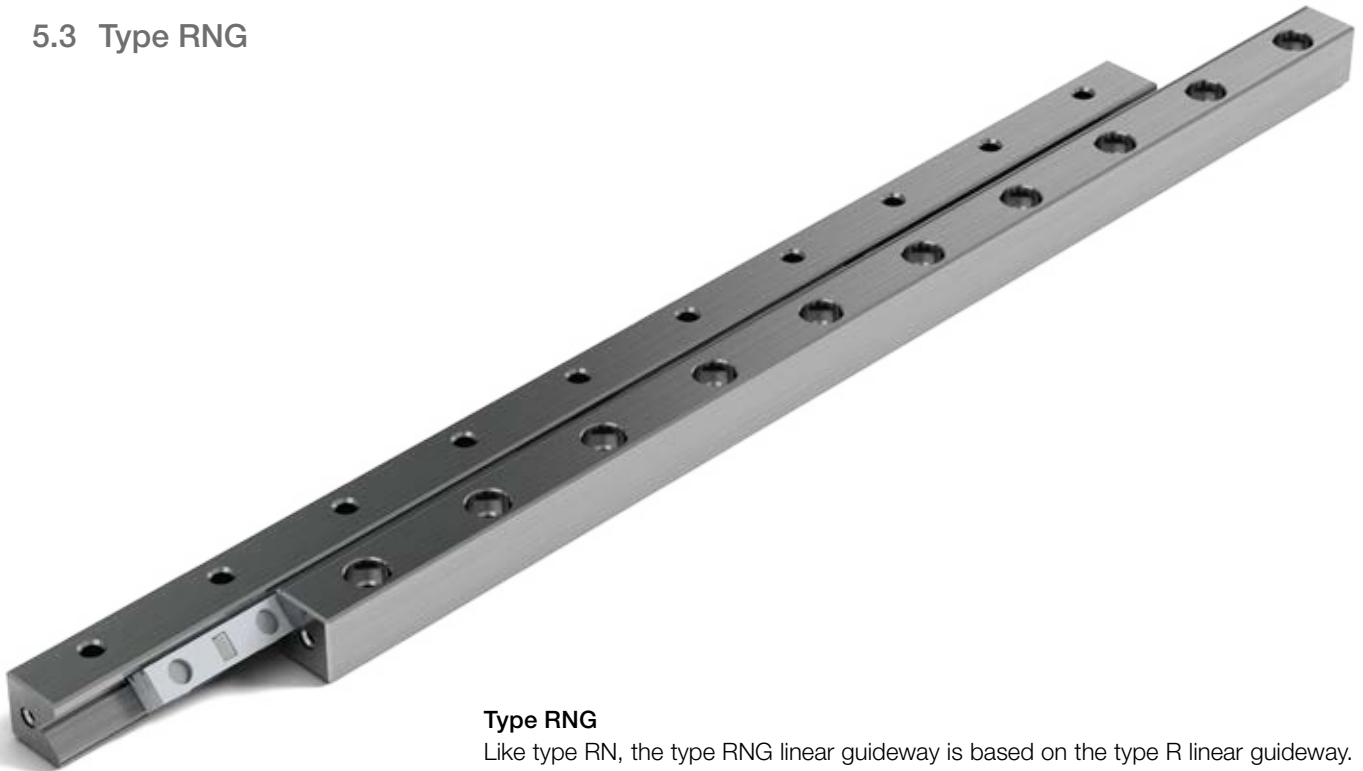

#### Type RNG

Like type RN, the type RNG linear guideway is based on the type R linear guideway. Like type RN, it has larger contact surfaces for the guideway tracks, which means its performance is significantly enhanced. Compared with types R and RN its cross-section is, however, smaller, which means that it represents a cost-effective solution without competition.

#### Benchmark data

Track and surface quality

- Finely ground supporting and/or locating surfaces and tracks (90° V-profile)

Materials (standard)

- Rails from through hardened tool steel 1.2842, hardness 58 - 62 HRC.
- For non-corrosive guideways tool steel 1.4034 is used.
- Rolling element made of through hardened roller bearing steel, hardness 58 - 64 HRC.

Rolling element

- Roller

Speed

- 1 m/s
- 1 m/s with cage control

Acceleration

- 50 m/s<sup>2</sup>
- 300 m/s<sup>2</sup> with cage control

Accuracy

- RNG linear guideways are available in three quality classes (see chapter 9)

Operating temperatures

- -40° C to +80° C

**5** Linear guideways

Dimensions and load capacities of type RNG

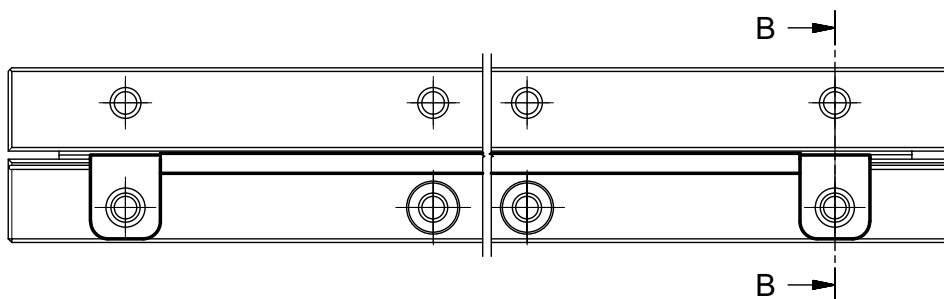
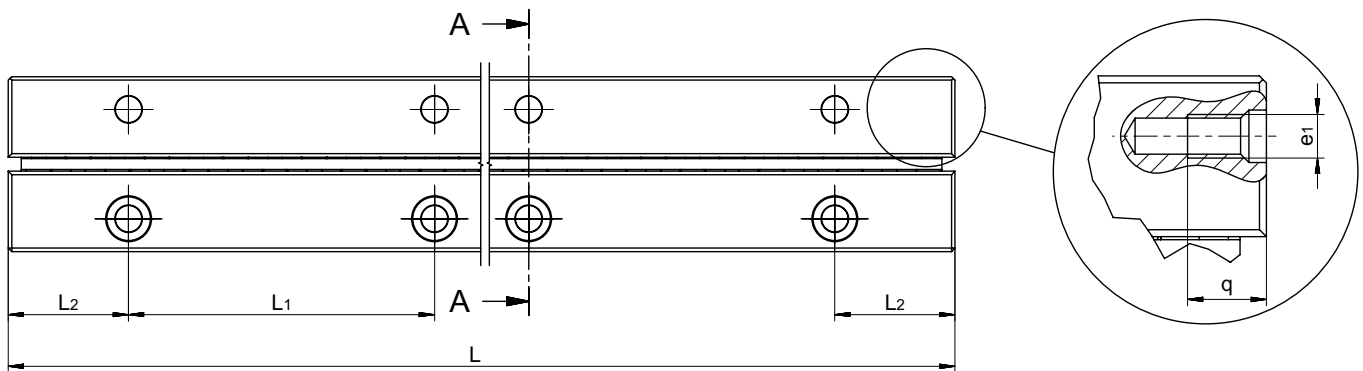

Type	Size	L in mm	Weight in g	A	B	Dw	J	L <sub>1</sub>	L <sub>2</sub>	N	d	e	e <sub>1</sub>	f	g	m	q	u	s	Options (see chapter 7)	Accessories
				mm																	
RNG	4	50	27	19	9	4.5	9	25	12.5	3.5	5.5	M3	M3	2.65	6.3	3.5	6	-	0.85	SQ	Cage: - KBN 4 - KBS 4 End pieces: - GBN 4 - GCN 4 - GCN-A 4 Fastening screw: - GDN 4
		75	41																	SSQ	
		100	55																	RF	
		125	69																	EG	
		150	83																	ZG	
		175	97																	HA	
		200	111																	DU	
		225	125																	DR	
		250	139																	KS	
		275	153																		
300	167																				
RNG	6	100	92	25	12	6.5	12	25	12.5	5	7	M4	M3	3.3	8.8	5	6	-	0.85	SQ	Cage: - KBN 6 - KBS 6 End pieces: - GBN 6 - GCN 6 - GCN-A 6 Fastening screw: - GDN 6
		150	138																	SSQ	
		200	184																	RF	
		250	230																	EG	
		300	276																	ZG	
		350	322																	HA	
		400	368																	DU	

**5** Linear guideways

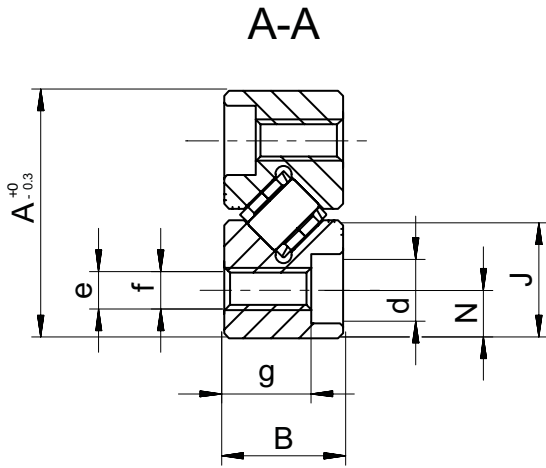

RNG 4-6

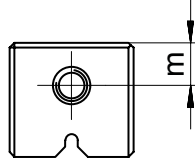

RNG 9-12

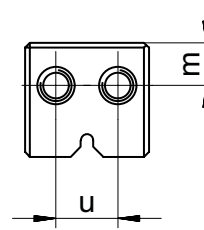

B-B

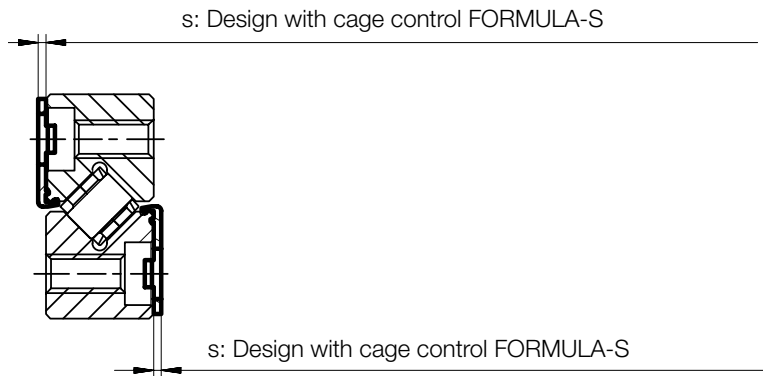

Type	Size	L in mm	Weight in g	A	B	Dw	J	L <sub>1</sub>	L <sub>2</sub>	N	d	e	e <sub>1</sub>	f	g	m	q	u	s	Options (see chapter 7)	Accessories
				mm																	
RNG	<b>9</b>	100	150	33	16	9	16	25	12.5	6	8.5	M5	M3	4.4	11.8	8	6	8	0.85	SQ SSQ RF EG ZG HA DU DR KS	Cage: - KBN 9 - KBS 9 End pieces: - GBN 9 - GCN 9 - GCN-A 9 Fastening screw: - GDN 9
		150	230																		
		200	310																		
		250	390																		
		300	470																		
		350	550																		
		400	630																		
		450	710																		
500	790																				
RNG	<b>12</b>	200	600	45	22	12	22	50	25	8	12	M8	M5	6.8	15.8	11	7.5	10	-	SQ SSQ RF EG ZG HA DU	Cage: - KBN 12 End pieces: - GBN 12 - GCN 12 - GCN-A 12 Fastening screw: - GDN 12
		300	905																		
		400	1'207																		
		500	1'508																		
		600	1'810																		
		700	2'125																		
		800	2'430																		
		900	2'734																		
		1'000	3'038																		

The types in bold are standard. Other lengths and types RNG 15, RNG 18 and RNG 20 are available on request



## 5 Linear guideways

### Maximum lengths for type RNG

Type / Size	Quality class	Max. lengths in standard material (in mm)	Max lengths in non-corrosive material (in mm)
RNG4	NQ	900	900
	SQ		
	SSQ	600	600
RNG6	NQ	1'500	1'400
	SQ		1'200
	SSQ	1'200	900
RNG9	NQ	1'500	1'400
	SQ		1'200
	SSQ	1'200	900
RNG12	NQ	1'500	1'400
	SQ		1'200
	SSQ	1'200	900

### Rail chamfer

The detail of the rail chamfer is shown in the chart below. Please note that the part number and company logo are marked opposite to the datum and supporting surfaces.

Type / Size	Rail chamfer of reference edges in mm
RNG 4	0.4 x 45°
RNG 6	0.5 x 45°
RNG 9	0.8 x 45°
RN 12	0.8 x 45°

## 5 Linear guideways

### Type RNG accessories

#### Roller cage type KBN

**Compatible with:**

Type RNG linear guideway  
Sizes 4 to 12

**Design:**

Rollers fixed in place

**Installation method:**

For normal application and certain  
overrunning cage applications

**Material:**

POM (Vacuum-compatible up to  $10^{-7}$   
mbar)

**Option:**

Corrosion-resistant rollers

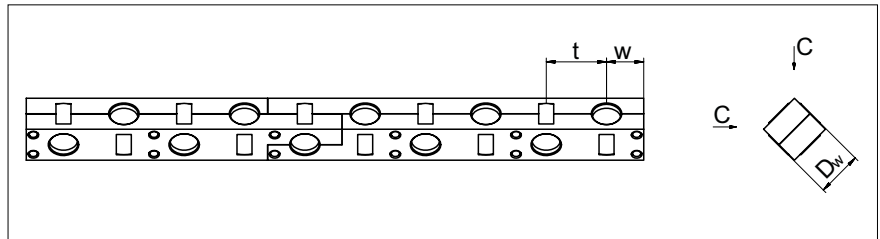

Type	Size	Dw	t	w	C per roller in N	Max. length in mm
KBN	4	4.5	6.5	approx. 4	850	900
	6	6.5	8.5	approx. 5	1'800	1'500
	9	9	12	approx. 7.5	3'900	1'500
	12	12	15	approx. 9	6'500	1'500

#### Type KBS roller cage for the cage control FORMULA-S

Detailed information on  
FORMULA-S is listed under chapter  
7.8.

**Compatible with:**

Type RNG linear guideway  
Sizes 4 to 9

**Design:**

Rollers fixed in place  
With integral pinion

**Installation method:**

For normal application and certain  
overrunning cage applications

**Material:**

POM (Vacuum-compatible up to  $10^{-7}$   
mbar)

**Option:**

Corrosion-resistant rollers

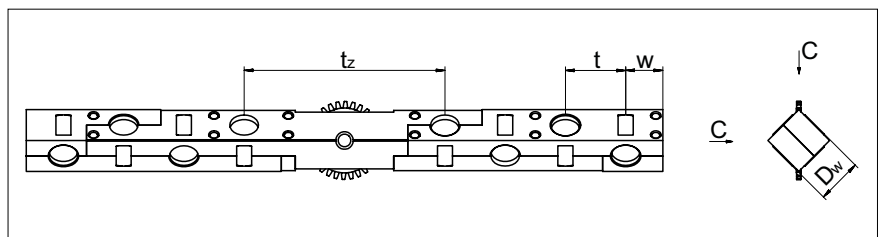

Type	Size	Dw	t	tz	w	C per roller in N	Max. length in mm
KBS	4	4.5	6.5	23	approx. 4	850	900
	6	6.5	8.5	27	approx. 5	1'800	1'500
	9	9	12	40	approx. 7.5	3'900	1'500

## 5 Linear guideways

### Type RNG accessories

#### End piece type GBN 4 and GBN 6

**Compatible with:**

Linear guideway RNG 4 and RNG 6

**Installation method:**

No restrictions

**Scope of supply:**

Including fastening screws

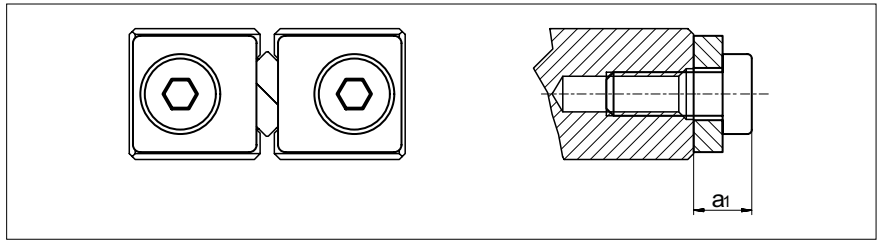

Size	GBN 4	GBN 6
a <sub>1</sub>	4	4

#### End piece type GBN 9 and GBN 12

**Compatible with:**

Linear guideway RNG 9 and RNG 12

**Installation method:**

No restrictions

**Scope of supply:**

Including fastening screws

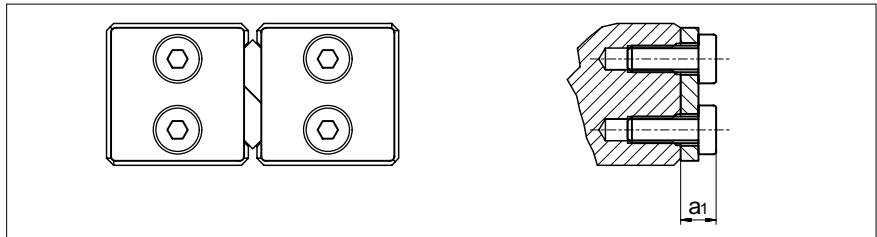

Size	GBN 9	GBN 12
a <sub>1</sub>	4	8.5

#### End piece type GCN 4 and GCN 6

**Special feature:**

For overrunning cage

**Compatible with:**

Linear guideway RNG 4 and RNG 6

**Installation method:**

No restrictions

**Scope of supply:**

Including fastening screws

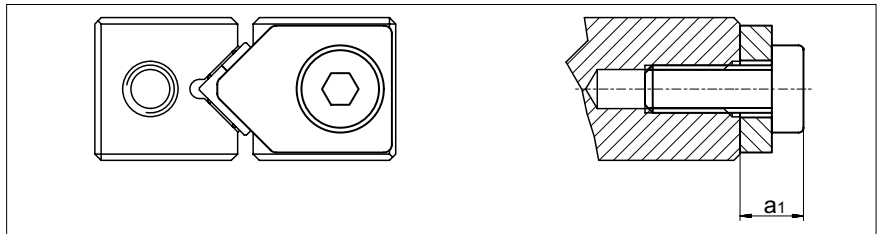

Size	GCN 4	GCN 6
a <sub>1</sub>	4	4

#### End piece type GCN 9 and GCN 12

**Special feature:**

For overrunning cage

**Compatible with:**

Linear guideway RNG 9 and RNG 12

**Installation method:**

No restrictions

**Scope of supply:**

Including fastening screws

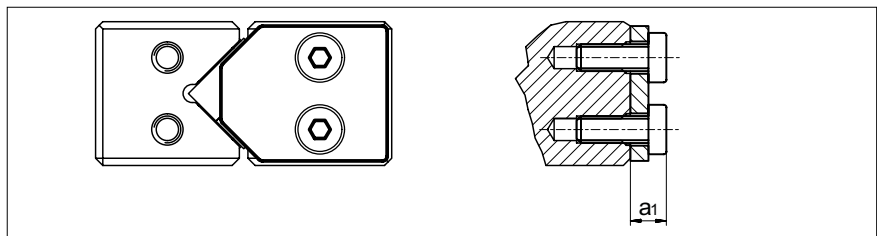

Size	GCN 9	GCN 12
a <sub>1</sub>	4	8.5

## 5 Linear guideways

### Type RNG accessories

#### End piece type GCN-A 4 and GCN-A 6

**Special feature:**

With wipers made of felt

**Compatible with:**

Linear guideway RNG 4 and RNG 6

**Installation method:**

No restrictions

**Scope of supply:**

Including fastening screws

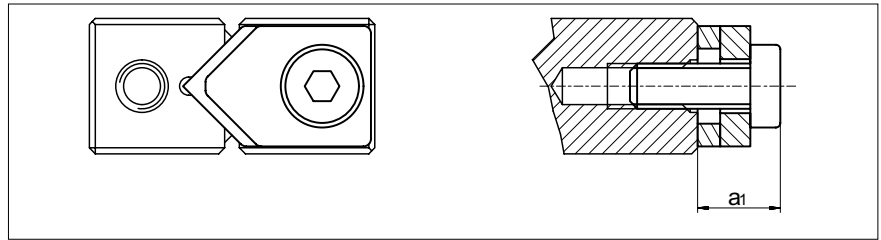

Size	GCN-A 4	GCN-A 6
$a_1$	5.5	5.5

#### End piece type GCN-A 9 and GCN-A 12

**Special feature:**

With wipers made of felt

**Compatible with:**

Linear guideway RNG 9 and RNG 12

**Installation method:**

No restrictions

**Scope of supply:**

Including fastening screws

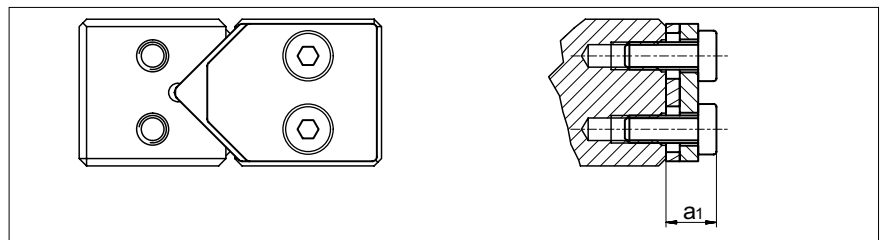

Size	GCN-A 9	GCN-A 12
$a_1$	5.5	10

#### Fastening screws with thin shaft type GDN 4 to GDN 12

**Special feature:**

To even out differences in the hold spacings

**Compatible with:**

Linear guideway type RNG 4 to RNG 12

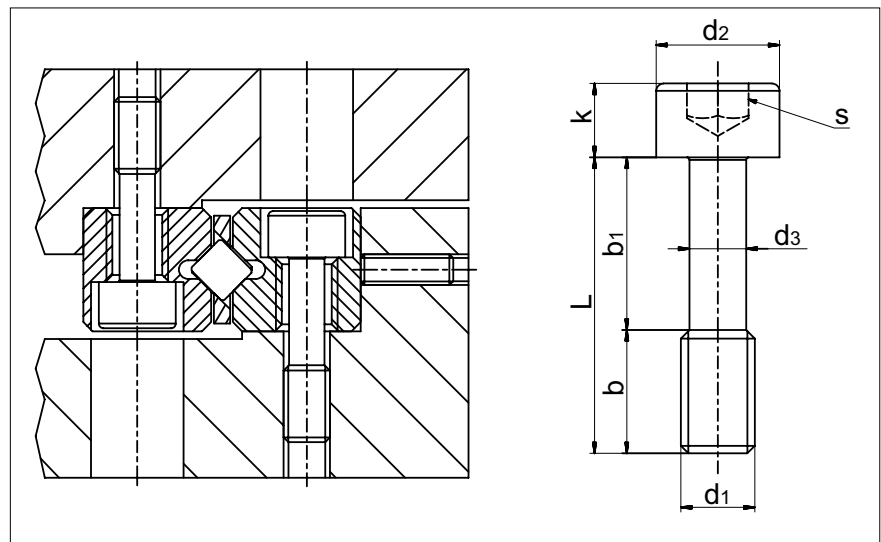

Type	Size	L	b	b <sub>1</sub>	d <sub>1</sub>	d <sub>2</sub>	d <sub>3</sub>	k	s	Tightening torque in Ncm
GDN	4	12	5	7	M2.5	4.5	1.85	2.5	2	58
	6	16	5	11	M3	5.5	2.3	3	2.5	102
	9	25	11	14	M4	7	3	4	3	323
	12	30	12	18	M5	10	4.6	6	5	792



## 5 Linear guideways

### 5.4 Type N/O



#### Type N/O

The type N/O linear guideways are equipped with needle cages and are particularly suitable for applications involving high loads. Compared with similar needle guideways, smaller displacement resistance values are recorded thanks to the use of the SCHNEEBERGER composite cage made of steel and plastic.

#### Benchmark data

Track and surface quality

- Finely ground supporting and/or locating surfaces and tracks (90° V-profile)

Materials (standard)

- Rails from through hardened tool steel 1.2842, hardness 58 - 62 HRC.
- For non-corrosive guideways tool steel 1.4034 is used.
- Rolling element made of through hardened roller bearing steel, hardness 58 - 64 HRC.

Rolling element

- Needle

Speed

- 1 m/s
- 1 m/s with cage control

Acceleration

- 50 m/s<sup>2</sup>
- 200 m/s<sup>2</sup> with cage control

Accuracy

- Type N/O linear guideways are available in three quality classes (see chapter 9)

Operating temperatures

- -40° C to +80° C

**5** Linear guideways

Dimensions and load capacities of type N/O

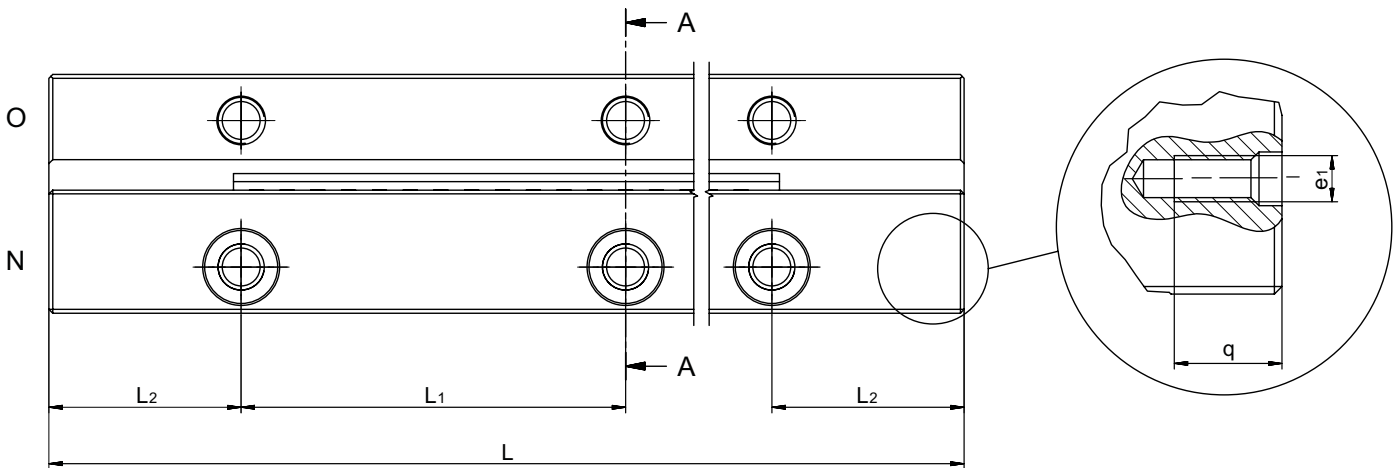

Type	Size	L in mm	Weight in g		A	B	Dw	F	J	J <sub>1</sub>	L <sub>1</sub>	L <sub>2</sub>	N	d	e	e <sub>1</sub>	f	g	m	m <sub>1</sub>	q	u	u <sub>1</sub>	Options (see chapter 7)	Accessories
			Type N	Type O																					
N/O	62'015	100	146	164	31	15	2	11	16	18	50	25	6	9.5	M6	M3	5.2	9.8	7.5	4.5	7	7	7	SQ SSQ RF EG ZG HA DU KZST	Cage: - HW 10 End pieces - GFN 62015 - GFO 62015 - GH 62015 - GH-A 62015 - GW 62015 - GW-A 62015 Fastening screw: - GD 6
		150	219	246																					
		200	292	328																					
		250	365	410																					
		300	438	492																					
		350	511	574																					
		400	584	656																					
		450	657	738																					
500	730	820																							
N/O	92'025	200	685	695	44	22	2	15	24	24.5	100	50	9	10.5	M8	M4	6.8	15.8	11	6	11	10	10	SQ SSQ RF EG ZG HA DU KZST	Cage: - HW 15 - SHW 15 End pieces - GFN 92025 - GFO 92025 - GH 92025 - GH-A 92025 - GW 92025 - GW-A 92025 Fastening screw: - GD 9
		300	1'020	1'030																					
		400	1'360	1'373																					
		500	1'700	1'717																					
		600	2'025	2'035																					
		700	2'360	2'370																					
		800	2'697	2'709																					
N/O	2'025	200	924	900	52	25	2	18	28	29	100	50	10	13.5	M10	M6	8.5	16.8	12	7	11	14	11	SQ SSQ RF EG ZG HA DUt KZST	Cage: - SHW 15 End pieces - GFN 2025 - GFO 2025 - GH 2025 - GH-A 2025 - GW 2025 - GW-A 2025 Fastening screw: - GD 2025
		300	1'386	1'350																					
		400	1'848	1'800																					
		500	2'310	2'250																					
		600	2'772	2'700																					
		700	3'234	3'150																					
		800	3'696	3'600																					
		900	4'158	4'050																					
		1'000	4'620	4'500																					
		1'100	5'082	4'950																					
		1'200	5'544	5'400																					
		1'400	6'468	6'300																					
1'600	7'392	7'200																							

Sold & Serviced By:

**ELECTROMATE**

Toll Free Phone (877) SERV098  
Toll Free Fax (877) SERV099  
www.electromate.com  
sales@electromate.com

**5** Linear guideways

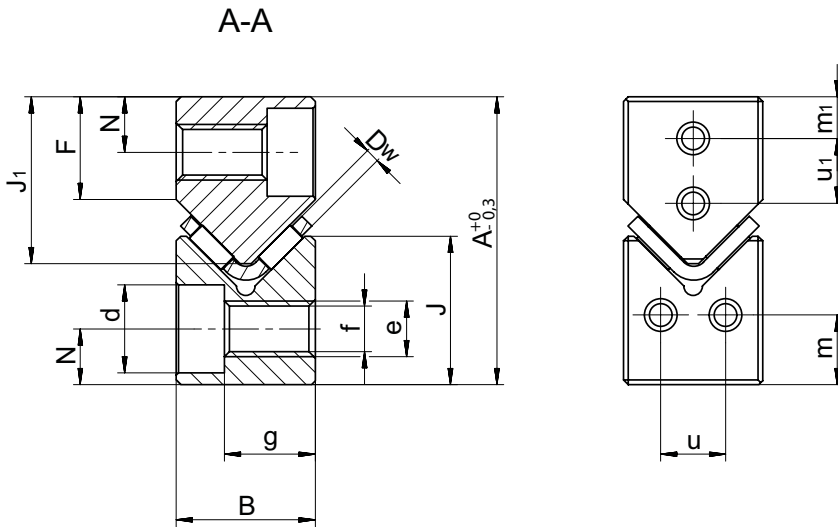

Type	Size	L in mm	Weight in g		A	B	Dw	F	J	J <sub>1</sub>	L <sub>1</sub>	L <sub>2</sub>	N	d	e	e <sub>1</sub>	f	g	m	m <sub>1</sub>	q	u	u <sub>1</sub>	Options (see chapter 7)	Accessories
			Type N	Type O																					
N/O	2'535	300	1'905	1'995	62	30	2.5	22	34	35	100	50	12	16.5	M12	M6	10.5	19.8	15	8	11	18	12	SQ SSQ RF EG ZG HA DU KZST	Cage: - HW 20 - SHW 20 End pieces - GFN 2535 - GFO 2535 - GH 2535 - GH-A 2535 - GW 2535 - GW-A 2535 Fastening screw: - GD 2535
		400	2'540	2'660																					
		500	3'175	3'325																					
		600	3'810	3'990																					
		700	4'445	4'655																					
		800	5'080	5'320																					
		900	5'715	5'985																					
		1'000	6'350	6'650																					
		1'100	6'985	7'315																					
		1'200	7'620	7'980																					
		1'400	8'890	9'310																					
1'600	10'160	10'640																							
N/O	3'045	400	3'660	3'460	74	35	3	25	42.5	40	100	50	14	18.5	M14	M6	12.5	22.8	18	10	11	19	16	SQ SSQ RF EG ZG HA DU KZST	Cage: - HW 25 - SHW 25 End pieces - GFN 3045 - GFO 3045 - GH 3045 - GH-A 3045 - GW 3045 - GW-A 3045 Fastening screw: - GD 3045
		500	4'575	4'325																					
		600	5'490	5'190																					
		700	6'405	6'055																					
		800	7'320	6'920																					
		900	8'235	7'785																					
		1'000	9'150	8'650																					
		1'100	1'007	9'515																					
		1'200	10'980	10'380																					
		1'400	12'810	12'110																					
		1'600	14'640	13'840																					
N/O	3'555	500	6'156	6'088	78	45	3.5	25	45	45	100	50	14	18.5	M14	M6	12.5	32.5	18	12	11	29	20	SQ SSQ RF EG ZG HA DU KZST	Cage: - HW 30 - SHW 30 End pieces - GFN 3555 - GFO 3555 - GH 3555 - GH-A 3555 - GW 3555 - GW-A 3555 Fastening screw: - GD 3555
		600	7'387	7'306																					
		700	8'618	8'523																					
		800	9'850	9'741																					
		900	11'081	10'958																					
		1'000	12'312	12'176																					
		1'100	13'543	13'394																					
		1'200	14'774	14'611																					
		1'400	17'237	17'046																					
		1'600	19'699	19'482																					

The types in bold are standard. Other lengths are available on request



## 5 Linear guideways

### Maximum lengths type N/O

Type /Size	Quality class (see chapter 9)	Max. lengths in standard material (in mm)	Max lengths in non-corrosive material (in mm)
N/O 62015	NQ	1'500	900
	SQ	1'200	
	SSQ		
N/O 92025	NQ	3'000	1'300
	SQ		
	SSQ		
N/O 2025	NQ	3'000	1'300
	SQ		
	SSQ		
N/O 2535	NQ	3'000	1'300
	SQ		
	SSQ		
N/O 3045	NQ	3'000	1'300
	SQ		
	SSQ		
N/O 3555	NQ	3'000	1'300
	SQ		
	SSQ		

### Rail chamfer

The detail of the rail chamfer is shown in the chart below. Please note that the part number and company logo are marked opposite to the datum and supporting surfaces.

Type / Size	Rail chamfer of reference edges in mm
N/O 62015	0.5 x 45°
N/O 92025	0.5 x 45°
N/O 2025	0.5 x 45°
N/O 2535	0.5 x 45°
N/O 3045	1.0 x 45°
N/O 3555	1.0 x 45°

## 5 Linear guideways

### Accessories for type N/O

#### Needle cage type SHW

**Design:**

Needles fixed in plastic. Thus smaller displacement forces and smoother running.

**Installation method:**

For normal application and certain overrunning cage applications

**Material:**

Stainless steel and plastic PA 12 GF 30 %

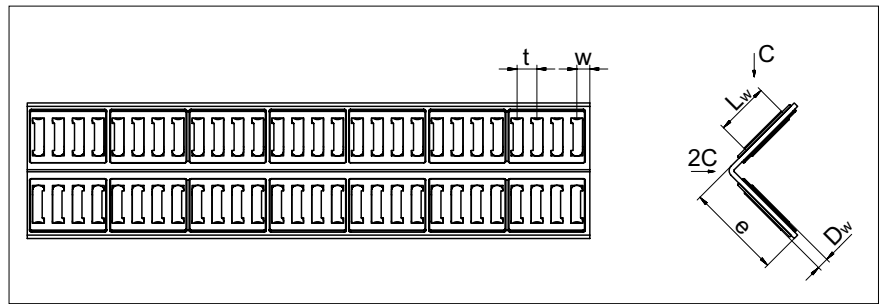

Type	Size	Dw	Lw	e	t	w	C per needle in N	Compatible with linear guideways type	max. length in mm
SHW	15	2	6.8	14	4	approx. 2.9	750	N/O 92025 and 2025	1'500
	20	2.5	9.8	19	4.75	approx. 3.4	1'375	N/O 2535	1'500
	25	3	13.8	25	5.2	approx. 3.6	2'350	N/O 3045	1'500
	30	3.5	17.8	30	6.1	approx. 4.3	3'600	N/O 3555	1'500

#### Needle cage type SHW with cage control (KZST)

Detailed information on the cage control is listed under Chapter 7.9.

**Design:**

Needles fixed in plastic. Thus smaller displacement forces and smoother running.

**Installation method:**

For normal application and certain overrunning cage applications

**Material:**

Stainless steel and plastic PA 12 GF 30 %

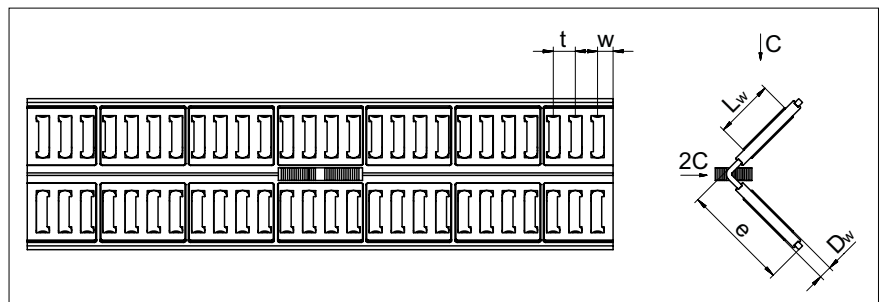

Type	Size	Dw	Lw	e	t	w	C per needle in N	Compatible with linear guideways type	max. length in mm
SHW	15	2	6.8	14	4	approx. 2.9	750	N/O 92025 and 2025	1'500
	20	2.5	9.8	19	4.75	approx. 3.4	1'375	N/O 2535	1'500
	25	3	13.8	25	5.2	approx. 3.6	2'350	N/O 3045	1'500
	30	3.5	17.8	30	6.1	approx. 4.3	3'600	N/O 3555	1'500

## 5 Linear guideways

### Accessories for type N/O

#### Needle cage type HW

**Design:**

Needles fixed

**Installation method:**

For normal application and certain overrunning cage applications

**Material:**

- Size HW 10 is made out of tool steel
- All other sizes in aluminium

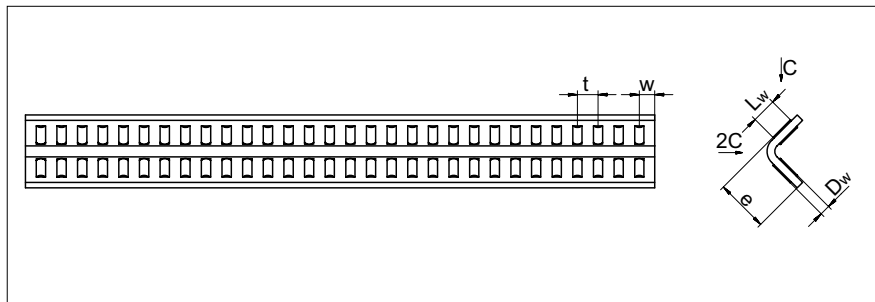

Type	Size	Dw	L <sub>w</sub>	e	t	w	C per needle in N	Compatible with linear guideways type	max. length in mm
HW	10	2	4.8	10	4	approx. 3	530	N/O 62015	1'980
	15	2	6.8	14	4.5	approx. 3.5	750	N/O 92025	1'950
	20	2.5	9.8	20	5.5	approx. 4	1'375	N/O 2535	1'970
	25	3	13.8	25	6	approx. 4.5	2'350	N/O 3045	1'940
	30	3.5	17.8	30	7	approx. 5	3'600	N/O 3555	1'980

#### Needle cage type HW with cage control (KZST)

Detailed information on the cage control is listed under Chapter 7.9.

**Design:**

Needles fixed

**Installation method:**

For normal application and certain overrunning cage applications

**Material:**

- Size HW 10 is made out of tool steel
- All other sizes in aluminium

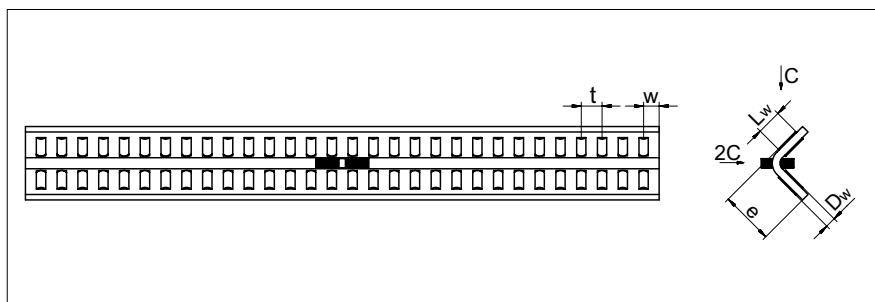

Type	Size	Dw	L <sub>w</sub>	e	t	w	C per needle in N	Compatible with linear guideways type	max. length in mm
HW	10	2	4.8	10	4	approx. 3	530	N/O 62015	1'980
	15	2	6.8	14	4.5	approx. 3.5	750	N/O 92025	1'950
	20	2.5	9.8	20	5.5	approx. 4	1'375	N/O 2535	1'970
	25	3	13.8	25	6	approx. 4.5	2'350	N/O 3045	1'940
	30	3.5	17.8	30	7	approx. 5	3'600	N/O 3555	1'980

## 5 Linear guideways

### Accessories for type N/O

#### End piece type GH

**Special feature:**

For overrunning cage

**Installation method:**

No restrictions

**Scope of supply:**

Including fastening screws

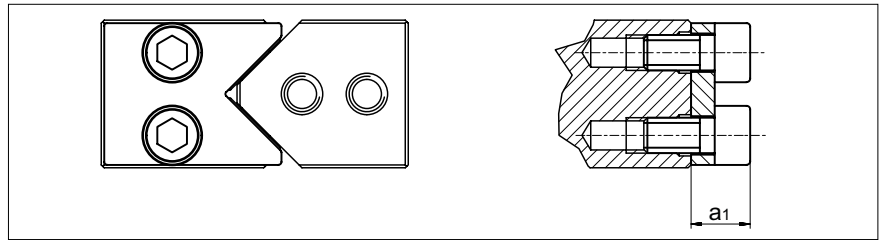

Size	62'015	92'025	2'025	2'535	3'045	3'555
a <sub>1</sub>	6	7	10	10	10	11

#### End piece type GH-A

**Special feature:**

Wipers made of felt

**Installation method:**

No restrictions

**Scope of supply:**

Including fastening screws

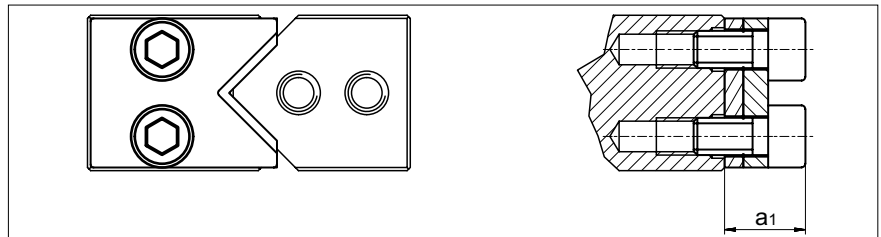

Size	62'015	92'025	2'025	2'535	3'045	3'555
a <sub>1</sub>	9	10	13	13	13	14

#### End piece type GFN/GFO

**Special feature:**

Wipers made of felt

**Installation method:**

No restrictions

**Scope of supply:**

Including fastening screws

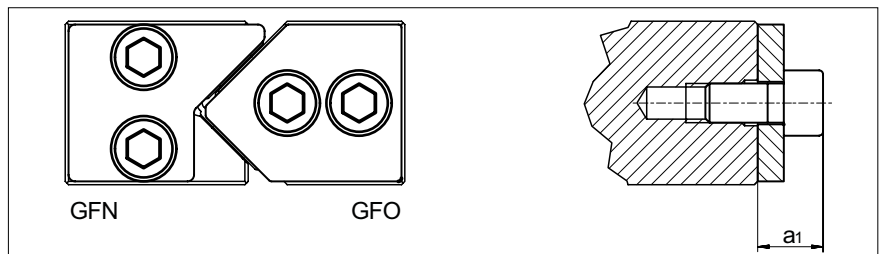

Size	62'015	92'025	2'025	2'535	3'045	3'555
a <sub>1</sub>	6	7	10	10	10	11

#### End piece type GW

**Special feature:**

For overrunning cage

**Installation method:**

No restrictions

**Scope of supply:**

Including fastening screws

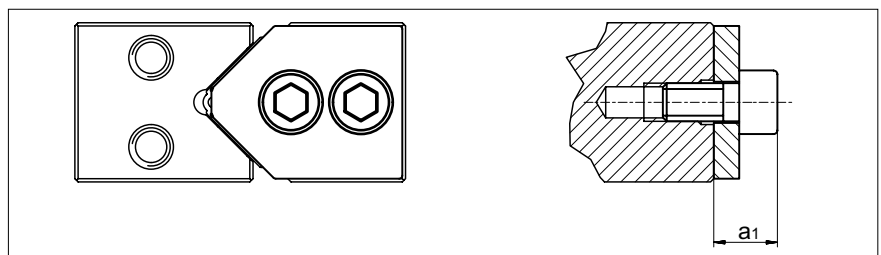

Size	62'015	92'025	2'025	2'535	3'045	3'555
a <sub>1</sub>	6	7	10	10	10	11

## 5 Linear guideways

### Accessories for type N/O

#### End piece type GW-A

**Special feature:**

Wipers made of felt

**Installation method:**

No restrictions

**Scope of supply:**

Including fastening screws

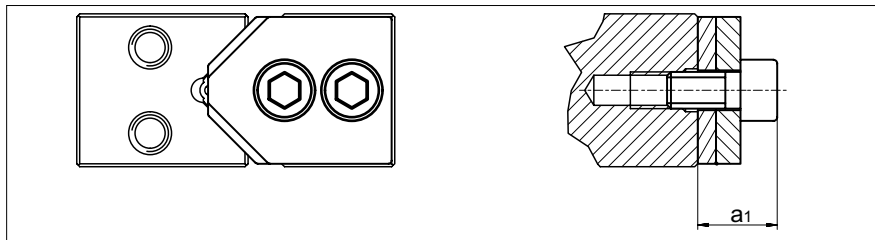

Size	62'015	92'025	2'025	2'535	3'045	3'555
a <sub>1</sub>	9	10	13	13	13	14

#### Fastening screws with thin shaft type GD

**Special feature:**

To even out differences in the hold spacings

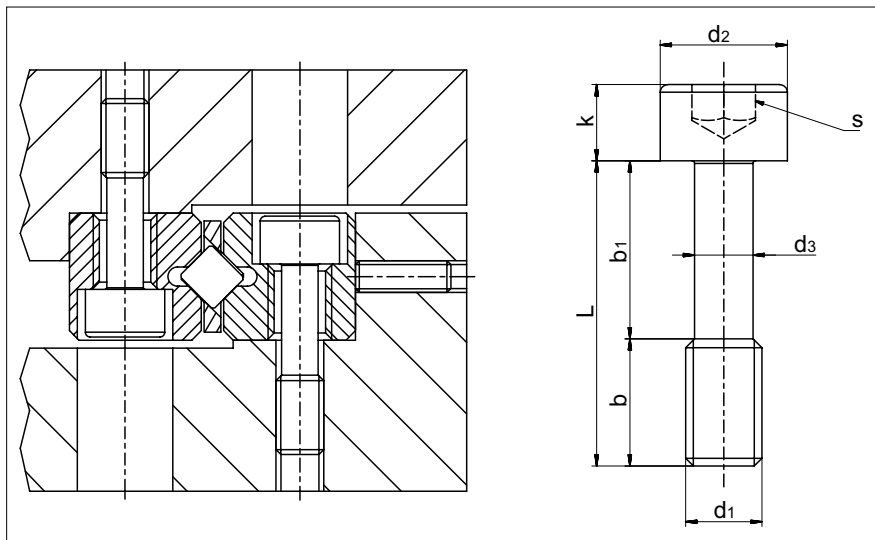

Type	Size	L	b	b <sub>1</sub>	d <sub>1</sub>	d <sub>2</sub>	d <sub>3</sub>	k	s	Compatible with linear guideways type
GD	6	20	8	12	M5	8	3.9	5	4	N/O 62015
	9	30	12	18	M6	8.5	4.6	6	5	N/O 92025
	2'025	35	16	19	M8	11.3	6.25	8	6	N/O 2025
	2'535	40	18	22	M10	13.9	7.9	10	8	N/O 2535
	3'045	50	25	25	M12	15.8	9.6	12	10	N/O 3045
	3'555	60	25	35	M12	15.8	9.6	12	12	N/O 3555

## 5 Linear guideways

### 5.5 Type M/V



#### Type M/V

the type M/V linear guideway is similar to type N/O, but differs in its external dimensions. Equipped with needle cages, it is particularly suitable for applications involving a higher load. Compared with similar needle guideways, smaller displacement resistance values are recorded thanks to the use of the SCHNEEBERGER composite cage.

#### Benchmark data

Track and surface quality

- Finely ground supporting and/or locating surfaces and tracks (90° V-profile)

Materials (standard)

- Rails from through hardened tool steel 1.2842, hardness 58 - 62 HRC.
- For non-corrosive guideways tool steel 1.4034 is used.
- Rolling element made of through hardened roller bearing steel, hardness 58 - 64 HRC.

Rolling element

- Needle

Speed

- 1 m/s
- 1 m/s with cage control

Acceleration

- 50 m/s<sup>2</sup>
- 200 m/s<sup>2</sup> with cage control

Accuracy

- Type M/V linear guideways are available in three quality classes (see chapter 9)

Operating temperatures

- -40° C to +80° C

**5** Linear guideways

Dimensions and load capacities type M/V

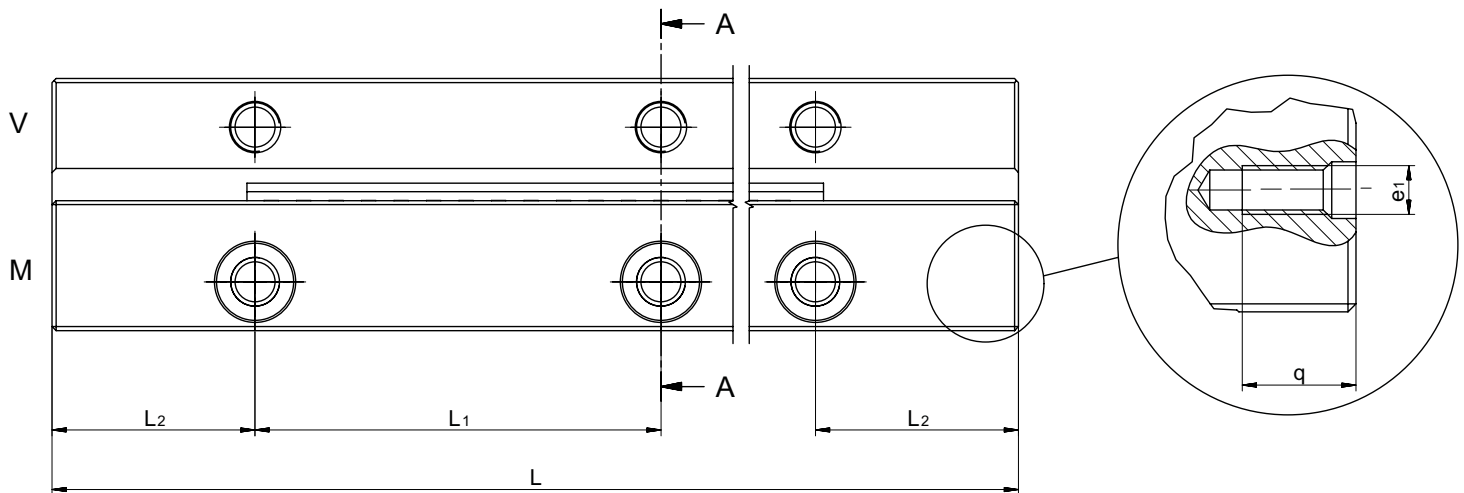

Type	Size	L in mm	Weight in g		A	B	Dw	F	J	J <sub>1</sub>	L <sub>1</sub>	L <sub>2</sub>	N	a	d	e	e <sub>1</sub>	f	g	m	m <sub>1</sub>	q	t	u	u <sub>1</sub>	Options (see chapter 7)	Accessories
			Type M	Type V																							
M/V	3'015	100	136	154	30	15	2	10.5	15.5	17.4	140	3 <sup>3)</sup>	5.5	0.7	8.5	M4	M3	5.3	10.5	8	5.5	7	15	7	7	SQ SSQ RF EG ZG HA KZST	Cage: - HW 10  End pieces - EM 3015 - EV 3015 - EAM 3015 - EAV 3015
		150	204	231																							
		200	272	308																							
		300	420	473																							
		400	560	631																							
		500	700	788																							
600	840	946																									
M/V	4'020	100	261	274	40	20	2	13.5	22.5	22	280	4 <sup>4)</sup>	7.5	1.3	11.5	M6	M5	7.5	13.2	10	5.5	8	20	11	10.5	SQ SSQ RF EG ZG HA KZST	Cage: - HW 15 - SHW 15  End pieces - EM 4020 - EV 4020 - EAM 4020 - EAV 4020
		150	392	411																							
		200	522	548																							
		300	820	815																							
		400	1'093	1'087																							
		500	1'367	1'358																							
600	1'640	1'630																									
M/V	5'025	100	446	437	50	25	2	17	28	28	280	4 <sup>4)</sup>	10	1.3	11.5	M6	M6	7.5	18.2	12	7	9	15	13	13	SQ SSQ RF EG ZG HA KZST	Cage: - HW 15 - HW 16 - SHW 15  End pieces - EM 5025 - EV 5025 - EAM 5025 - EAV 5025
		200	893	874																							
		300	1'339	1'311																							
		400	1'786	1'748																							
		500	2'232	2'185																							
		600	2'678	2'622																							
		700	3'125	3'059																							
		800	3'571	3'496																							
		900	4'018	3'933																							
		1'000	4'464	4'370																							

<sup>1)</sup> for the 100 mm length, the following applies: L<sub>1</sub> = 35 mm (2 x )

<sup>2)</sup> for the length 100 mm, the following applies: L<sub>1</sub> = 50 mm

<sup>3)</sup> min. 15 mm

<sup>4)</sup> min. 20 mm

**5** Linear guideways

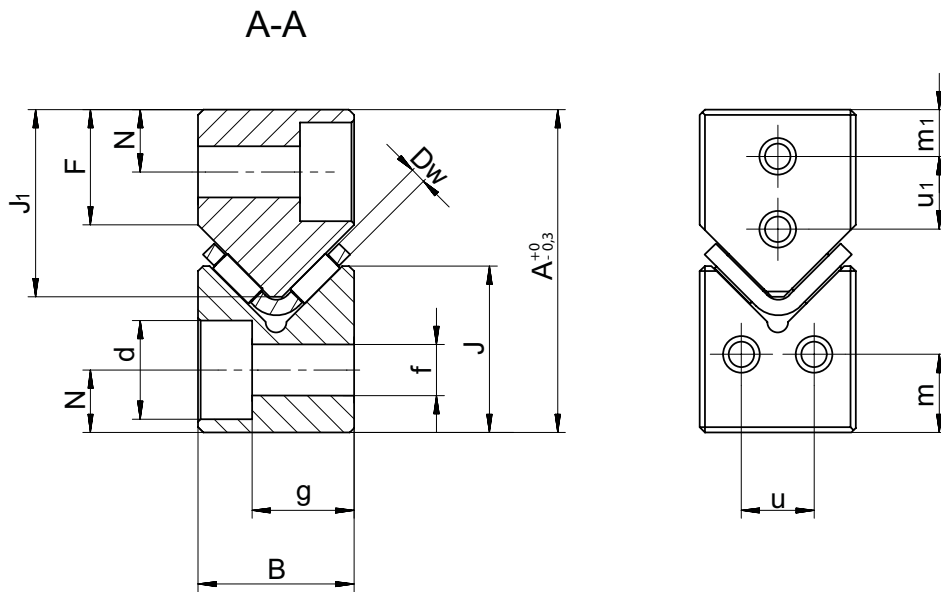

Type	Size	L in mm	Weight in g		A	B	Dw	F	J	J <sub>1</sub>	L <sub>1</sub>	L <sub>2</sub>	N	a	d	e	e <sub>1</sub>	f	g	m	m <sub>1</sub>	q	t	u	u <sub>1</sub>	Options (see chapter 7)	Accessories
			Type N	Type O																							
M/V	6'035	<b>200</b>	1'450	1'510	60	35	2.5	20	35	35.5	100	50	11	1.3	15	M8	M6	10	26	14	8	9	20	20	18	SQ SSQ RF EG ZG HA KZST	Cage: - HW 20 - SHW20  End pieces - EM 6035 - EV 6035 - EAM 6035 - EAV 6035
		<b>300</b>	2'176	2'265																							
		<b>400</b>	2'901	3'020																							
		<b>500</b>	3'626	3'775																							
		<b>600</b>	4'351	4'530																							
		<b>700</b>	5'076	5'285																							
		<b>800</b>	5'802	6'040																							
		<b>900</b>	6'527	6'795																							
		<b>1'000</b>	7'252	7'550																							
M/V	7'040	<b>200</b>	1'934	2'008	70	40	3	24	40	41.5	100	50	13	1.3	18.5	M10	M6	12.5	29	16	10	9	25	20	20	SQ SSQ RF EG ZG HA KZST	Cage: - HW 25 - SHW 25  End pieces - EM 7040 - EV 7040 - EAM 7040 - EAV 7040
		<b>300</b>	2'807	3'019																							
		<b>400</b>	3'743	4'025																							
		<b>500</b>	4'678	5'032																							
		<b>600</b>	5'821	6'038																							
		<b>700</b>	6'791	7'044																							
		<b>800</b>	7'499	8'051																							
		<b>900</b>	8'436	9'057																							
		<b>1'000</b>	9'374	10'321																							
M/V	8'050	<b>300</b>	4'014	4'271	80	50	3.5	26	45	48	100	50	14	1.3	20	M12	M6	14	37	20	10	9	30	30	25	SQ SSQ RF EG ZG HA KZST	Cage: - HW 30 - SHW 30  End pieces - EM 8050 - EV 8050 - EAM 8050 - EAV 8050
		<b>400</b>	5'352	5'694																							
		<b>500</b>	6'690	7'118																							
		<b>600</b>	8'290	8'544																							
		<b>700</b>	9'672	9'968																							
		<b>800</b>	10'700	11'530																							
		<b>900</b>	12'038	12'822																							
				<b>1'000</b>																							

The lengths in bold are standard. Other lengths are available on request



## 5 Linear guideways

### Maximum lengths type M/V

Type / Size	Quality class	Max. lengths in standard material (in mm)	Max lengths in non-corrosive material (in mm)
M/V 3015	NQ	1'500	900
	SQ	1'200	
	SSQ		
M/V 4020	NQ	1'500	900
	SQ	1'200	
	SSQ		
M/V 5025	NQ	1'500	900
	SQ	1'200	
	SSQ		
M/V 6035	NQ	1'500	900
	SQ	1'200	
	SSQ		
M/V 7040	NQ	1'500	900
	SQ	1'200	
	SSQ		
M/V 8050	NQ	1'500	900
	SQ	1'200	

### Rail chamfer

The detail of the rail chamfer is shown in the chart below. Please note that the part number and company logo are marked opposite to the datum and supporting surfaces.

Type / Size	Rail chamfer of reference edges in mm
M/V 3015	0.5 x 45°
M/V 4020	0.5 x 45°
M/V 5025	0.5 x 45°
M/V 6035	0.5 x 45°
M/V 7040	1.0 x 45°
M/V 8050	1.0 x 45°

## 5 Linear guideways

### Accessories type M/V

#### Needle cage type SHW

**Compatible with:**

Linear guideway type M/V

**Design:**

Needles fixed in plastic. Thus smaller displacement forces and smoother running.

**Installation method:**

For normal application and certain overrunning cage applications

**Material:**

Stainless steel and plastic PA 12 GF 30 %

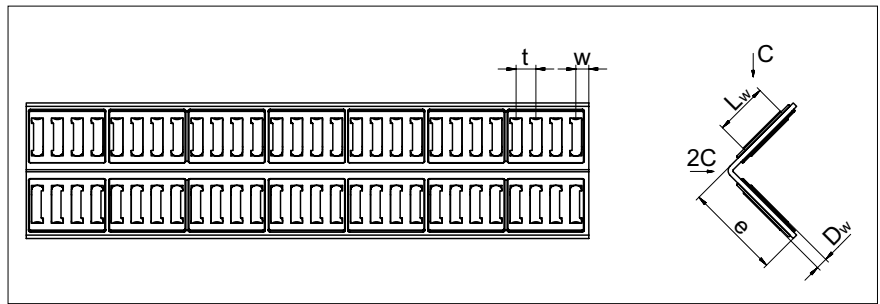

Type	Size	Dw	Lw	e	t	w	C per needle in N	Compatible with linear guideways type	max. length in mm
SHW	15	2	6.8	14	4	approx. 2.9	750	M/V 4020 and M/V 5025	1'500
	20	2.5	9.8	19	4.75	approx. 3.4	1'375	M/V 6035	1'500
	25	3	13.8	25	5.2	approx. 3.6	2'350	M/V 7040	1'500
	30	3.5	17.8	30	6.1	approx. 4.3	3'600	M/V 8050	1'500

#### Needle cage type SHW with cage control (KZST)

Detailed information on the cage control is listed under Chapter 7.9.

**Compatible with:**

Linear guideway type M/V

**Design:**

Needles fixed in plastic. Thus smaller displacement forces and smoother running.

**Installation method:**

For normal application and certain overrunning cage applications

**Material:**

Stainless steel and plastic PA 12 GF 30 %

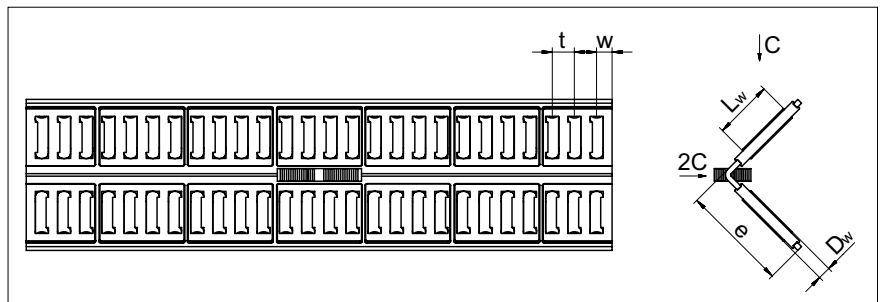

Type	Size	Dw	Lw	e	t	w	C per needle in N	Compatible with linear guideways type	max. length in mm
SHW	15	2	6.8	14	4	approx. 2.9	750	M/V 4020 and M/V 5025	1'500
	20	2.5	9.8	19	4.75	approx. 3.4	1'375	M/V 6035	1'500
	25	3	13.8	25	5.2	approx. 3.6	2'350	M/V 7040	1'500
	30	3.5	17.8	30	6.1	approx. 4.3	3'600	M/V 8050	1'500

## 5 Linear guideways

### Accessories type M/V

#### Needle cage type HW

**Compatible with:**

Linear guideway type M/V

**Design:**

Needles fixed

**Installation method:**

Specifically suitable as an overrunning cage

**Material:**

- Size HW 10 is made out of tool steel
- All other sizes in aluminium

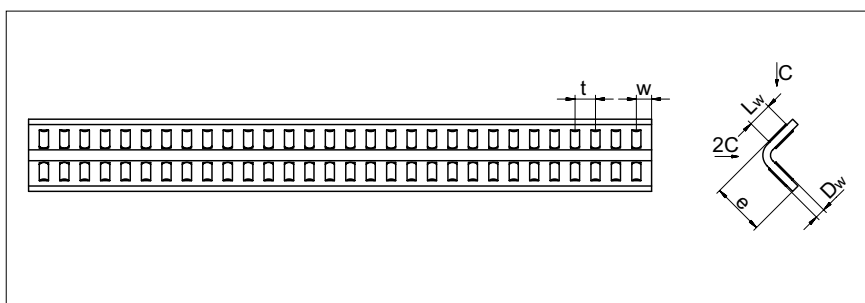

Type	Size	Dw	Lw	e	t	w	C per needle in N	Compatible with linear guideways type	max. length in mm
HW	10	2	4.8	10	4	approx. 3	530	M/V 3015	1'980
	15	2	6.8	14	4.5	approx. 3.5	750	M/V 4020 and M/V 5025	1'950
	16	2	8.8	16	3.8	approx. 2.8	970	M/V 5025	1'990
	20	2.5	9.8	20	5.5	approx. 4	1'375	M/V 6035	1'970
	25	3	13.8	25	6	approx. 4.5	2'350	M/V 7040	1'940
	30	3.5	17.8	30	7	approx. 5	3'600	M/V 8050	1'980

#### Needle cage type HW with cage control (KZST)

Detailed information on the cage control is listed under Chapter 7.9.

**Compatible with:**

Linear guideway type M/V

**Design:**

Needles fixed

**Installation method:**

Specifically suitable as an overrunning cage

**Material:**

- Size HW 10 is made out of tool steel
- All other sizes in aluminium

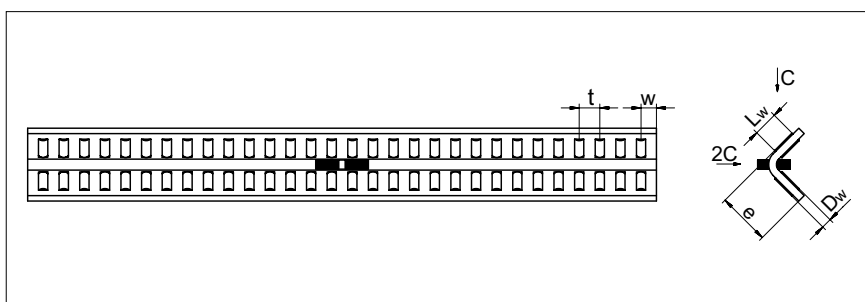

Type	Size	Dw	Lw	e	t	w	C per needle in N	Compatible with linear guideways type	max. length in mm
HW	10	2	4.8	10	4	approx. 3	530	M/V 3015	1'980
	15	2	6.8	14	4.5	approx. 3.5	750	M/V 4020 and M/V 5025	1'950
	16	2	8.8	16	3.8	approx. 2.8	970	M/V 5025	1'990
	20	2.5	9.8	20	5.5	approx. 4	1'375	M/V 6035	1'970
	25	3	13.8	25	6	approx. 4.5	2'350	M/V 7040	1'940
	30	3.5	17.8	30	7	approx. 5	3'600	M/V 8050	1'980

## 5 Linear guideways

### Accessories type M/V

#### End piece type EM/EV

**Compatible with:**  
For all M/V rail sizes

**Installation method:**  
No restrictions

**Scope of supply:**  
Including fastening screws

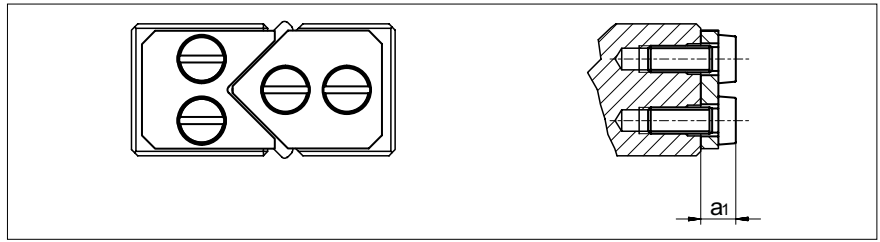

Size	3'015	4'020	5'025	6'035	7'040	8'050
$a_1$	5	8	9	9	9	9

#### End piece type EAM

**Special feature:**  
Wipers made of felt

**Compatible with:**  
For all M/V rail sizes

**Installation method:**  
No restrictions

**Scope of supply:**  
Including fastening screws

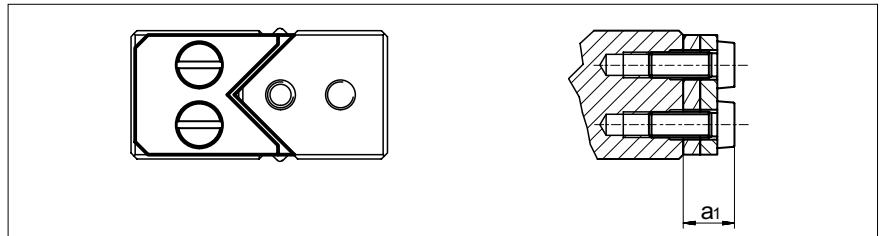

Size	3'015	4'020	5'025	6'035	7'040	8'050
$a_1$	7	10	11	11	11	11

#### End piece type EAV

**Special feature:**  
Wipers made of felt

**Compatible with:**  
For all M/V rail sizes

**Installation method:**  
No restrictions

**Scope of supply:**  
Including fastening screws

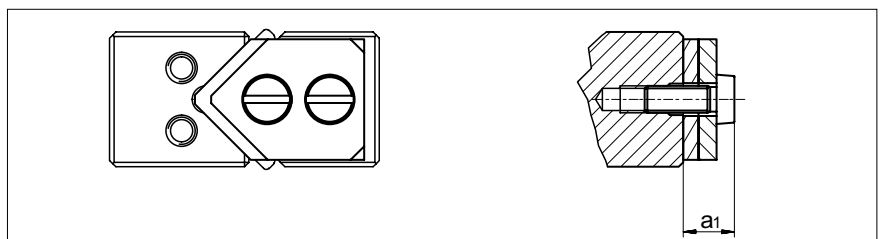

Size	3'015	4'020	5'025	6'035	7'040	8'050
$a_1$	7	10	11	11	11	11



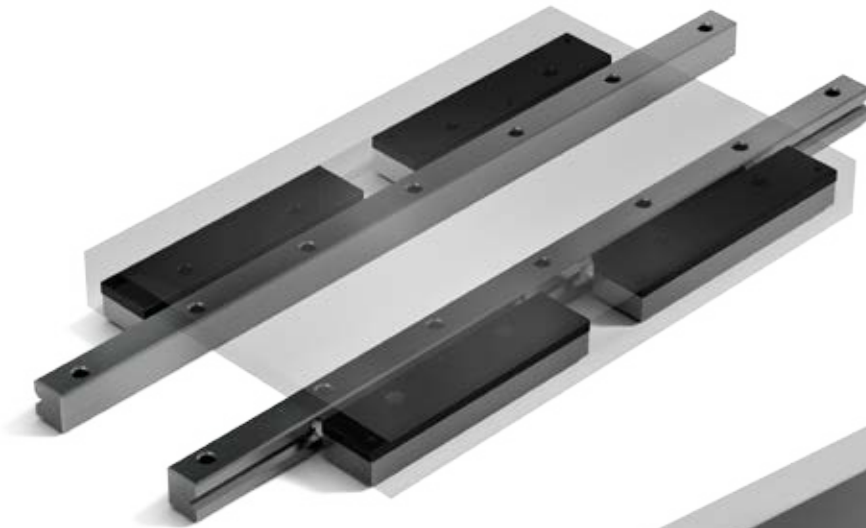

Application with recirculating units and linear guideways of type R



Application with recirculating units and a linear guideway of type RD

Recirculating units support high-precision, rigid and compact structures with unlimited travel. They are used as standard with linear guideways of type R or RD.

The SCHNEEBERGER product range includes recirculating units in different versions and for different load capacities; with rollers or balls, with damping elements or for dry runs.

The range is modular in structure and depending on the type includes sizes from 1 to 12.

## 6 Recirculating unit

### 6.1 Type SK and SKD



Type SK



Type SKD

The type SK recirculating unit is equipped with balls and is suitable for small to medium loads.

This recirculating unit is used combined with SCHNEEBERGER linear guideways of type R and/or RD. In this way space-saving designs can be created that can be equally loaded in all directions.

Sizes 6 and 9 (size 12 on request) can additionally be equipped with damping elements (type designation SKD). These provide improved smoothness with slightly reduced load carrying capacity.

#### Benchmark data

Supporting structure

- Hardened and ground with high precision

Materials

- Supporting structure made of through hardened tool steel, hardness 58 - 62 HRC
- Rolling element made of through hardened roller bearing steel, hardness 58 - 64 HRC
- Transmission part in sizes 1, 2, 9 and 12 made of anodized aluminium
- Transmission part in sizes 3 and 6t depending on the length made of plastic or aluminium
- Non-corrosive version on request
- Damping elements for SKD made of plastic
- Wipers made of plastic

Wipers

- From size 3 interchangeable track wipers are made from plastic as standard fitted

Speed

- 2 m/s

Acceleration

- 50 m/s<sup>2</sup>

Operating temperatures

- -40° C to +80° C

Same installation with the following recirculating units

- SKC and SR

Can be combined with the following products

- Linear guideway type R and RD

## 6 Recirculating unit

### Dimensions and load capacities type SK and SKD

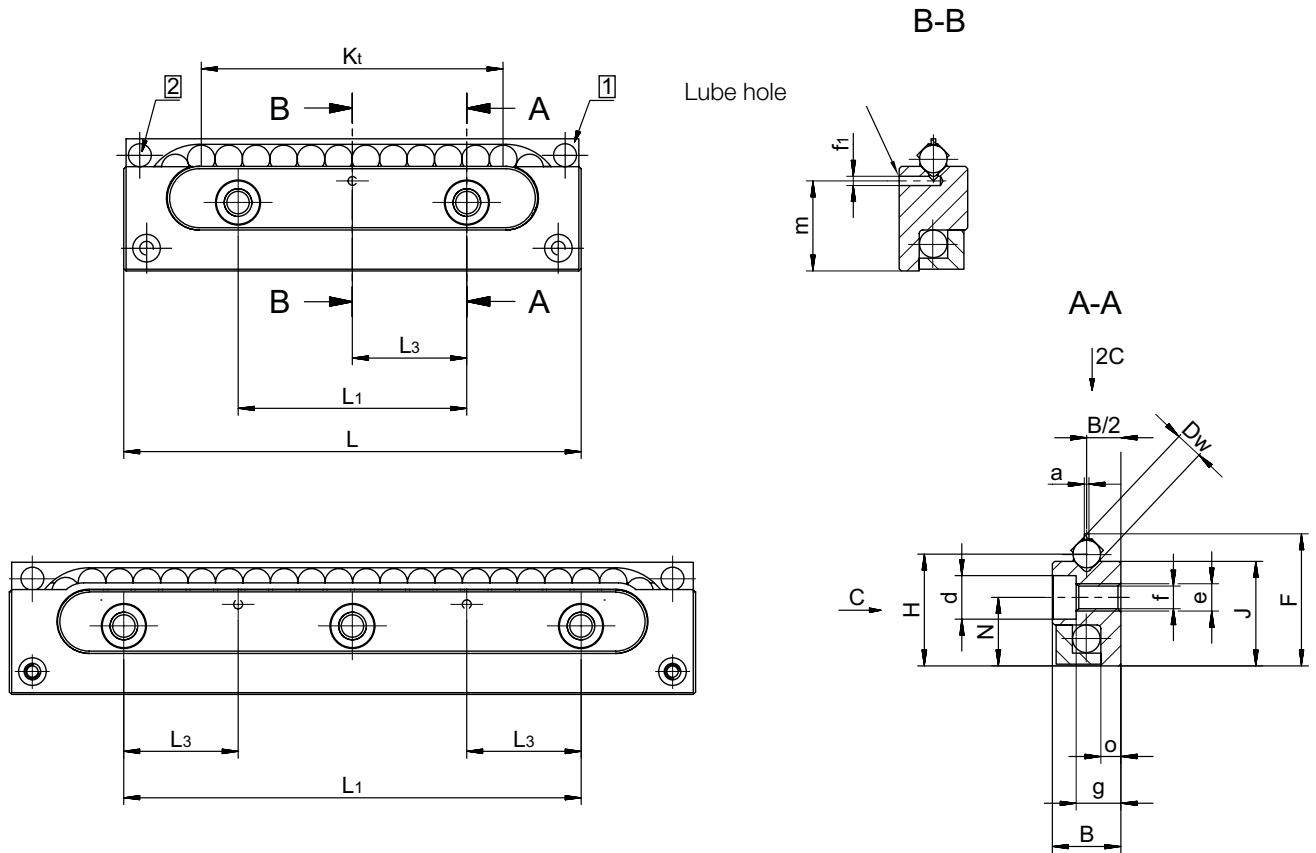

1 Retaining web may not be used as a stop

2 Wiper from size SK 3-075

Type and size	Weight in g	B	Dw	F	H	J	K <sub>1</sub>	L	L <sub>1</sub>	L <sub>3</sub>	N	a	d	e	f	f <sub>1</sub>	g	m	o	C in N		Options (see chapter 8)	
		SK	SKD	SK	SKD	SK	SKD	SK	SKD	SK	SKD	SK	SKD	SK	SKD	SK	SKD	SK	SKD	SK	SKD		
SK 1-022	5	4	1.5	8.4	7.25	6.9	9	22	10	-	4.8	0.3	3	M2	1.65	-	2.6	-	1.2	63		GP	
SK 2-032	10	6	2	11	9.5	9	16	32	15	-	6	0.3	4.4	M3	2.55	-	4	-	1.9	135		GP	
SK 3-075	45	8	3	16.9	14.5	13.8	48	75	25	12.5	9	0.5	6	M4	3.3	1.5	4.9	11.5	2.4	425		GP	
<b>SK 6-100</b>	<b>SKD 6-100</b>	200	15	6	28.9	24.5	22.9	60	100	50	25	15	1	9.5	M6	5.2	2	9.8	19.7	4.4	715	650	GP
<b>SK 6-150</b>	<b>SKD 6-150</b>	300						102	150	2 x 50											1'170	1'100	
<b>SK 9-150</b>	<b>SKD 9-150</b>	670	22	9	45.1	39	36.7	90	150	100	50	26	1.5	10.5	M8	6.8	3	15.8	32.4	6.3	1'650	1'500	GP
<b>SK 9-200</b>	<b>SKD 9-200</b>	940						144	200												2'550	2'400	
SK 12-200	SKD 12-200	1'470	28	12	57.1	49	45.9	120	200	100	50	32	2	13.5	M10	8.5	3	19.8	40.2	7.7	2'860	2'600	GP

The types in bold are standard. Types SK12 and SKD 12 are available on request



## 6 Recirculating unit

### Installed dimensions and permissible torque for type SK and SKD

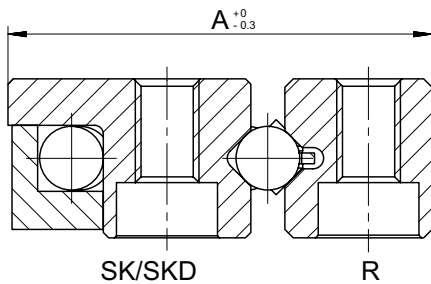

Installed dimensions for type SK and SKD

Type	Size	A	A <sub>1</sub>	e <sub>1</sub>
<b>SK</b>	<b>1-022</b>	11.5	28	M1.6
	<b>2-032</b>	15.5	37	M2.5
	<b>3-075</b>	23.5	57	M3
<b>SK and SKD</b>	<b>6-100</b>	40	94	M5
	<b>6-150</b>	40	94	M5
	<b>9-150</b>	61	150	M6
	<b>9-200</b>	61	150	M6
SK and SKD	12-200	78	175	M8

The types in bold are standard. Types SK12 and SKD 12 are available on request

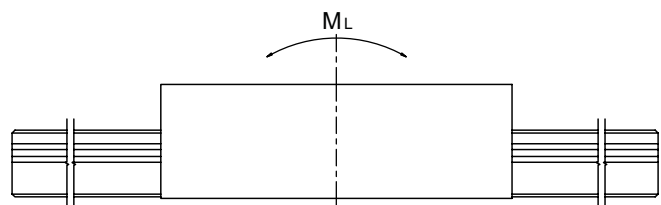
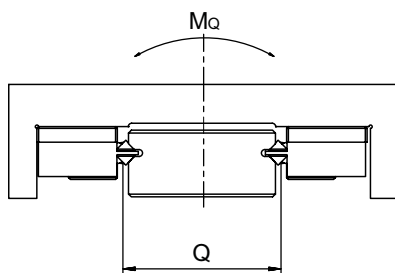
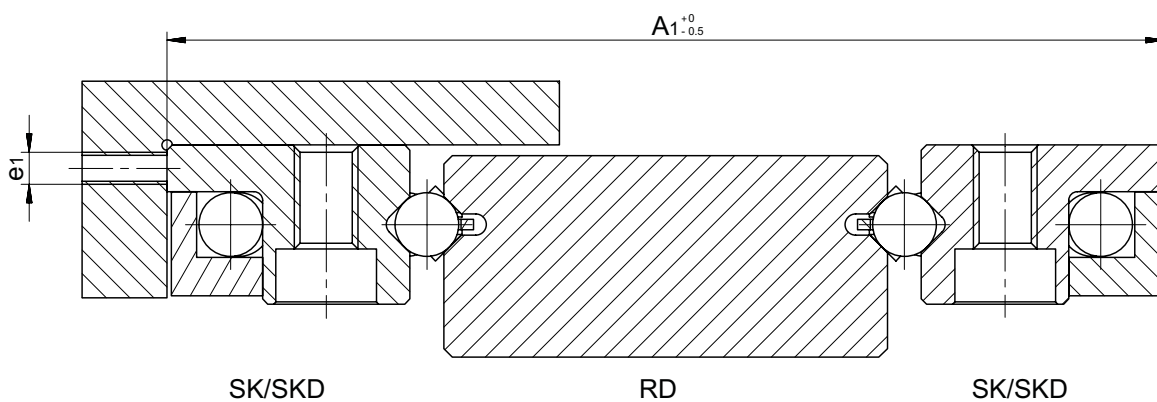

Permissible torques for type SK and SKD

Type	Size	Q	M <sub>L</sub> in Nm		M <sub>Q</sub> in Nm	
			SK	SKD	SK	SKD
<b>SK</b>	<b>1-023</b>	13.5	0.4		0.8	
	<b>2-033</b>	18.0	1.4		2.4	
	<b>3-076</b>	28.0	7.2		12.0	
<b>SK and SKD</b>	<b>6-100</b>	45.0	23.0	23.0	32.0	29.0
	<b>6-150</b>		40.0	40.0	53.0	50.0
	<b>9-150</b>	72.0	81.0	81.0	119.0	108.0
			130.0	130.0	184.0	173.0
SK and SKD	12-200	77.0	187.0	187.0	220.0	200.0

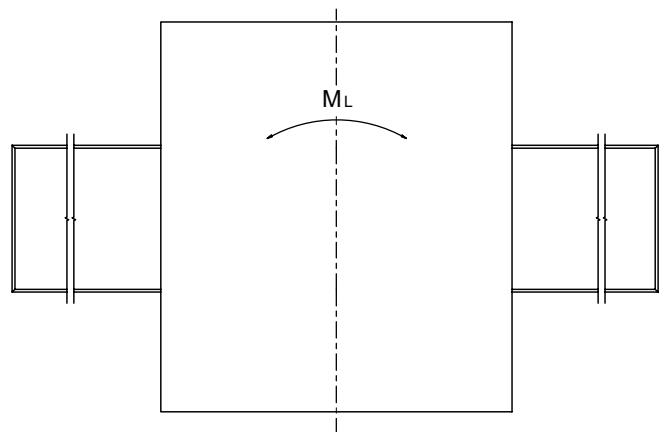

The types in bold are standard. Types SK12 and SKD 12 are available on request

## 6 Recirculating unit

### 6.2 Type SKC



The recirculating unit type SKC was developed for dry runs and in-vacuum and clean-room applications. It is made out of DURALLOY® coated steel and has ceramic balls, which are separated from one another by balls made out of TEFLON®.

This recirculating unit is used combined with SCHNEEBERGER linear guideways of type R and/or RD. In this way space-saving designs can be created that can be equally loaded in all directions. It is suitable for small to medium loads.

#### Benchmark data

##### Supporting structure

- Hardened and ground and coated with high precision

##### Materials

- Supporting structure made of stainless steel 1.4034, DURALLOY® coated, hardness 58 - 62 HRC
- Transmission part made out of stainless steel 1.4034
- Rolling element made of ceramic  
(balls made of TEFLON® between the ceramic balls are responsible for minimal friction)

##### Speed

- 2 m/s

##### Acceleration

- 50 m/s<sup>2</sup>

##### Operating temperatures

- -150° C to +200° C

##### Same installation with the following recirculating units

- SK, SKD and SR

##### Can be combined with the following products

- Linear guideway type R and RD

## 6 Recirculating unit

### Dimensions and load capacities of type SKC

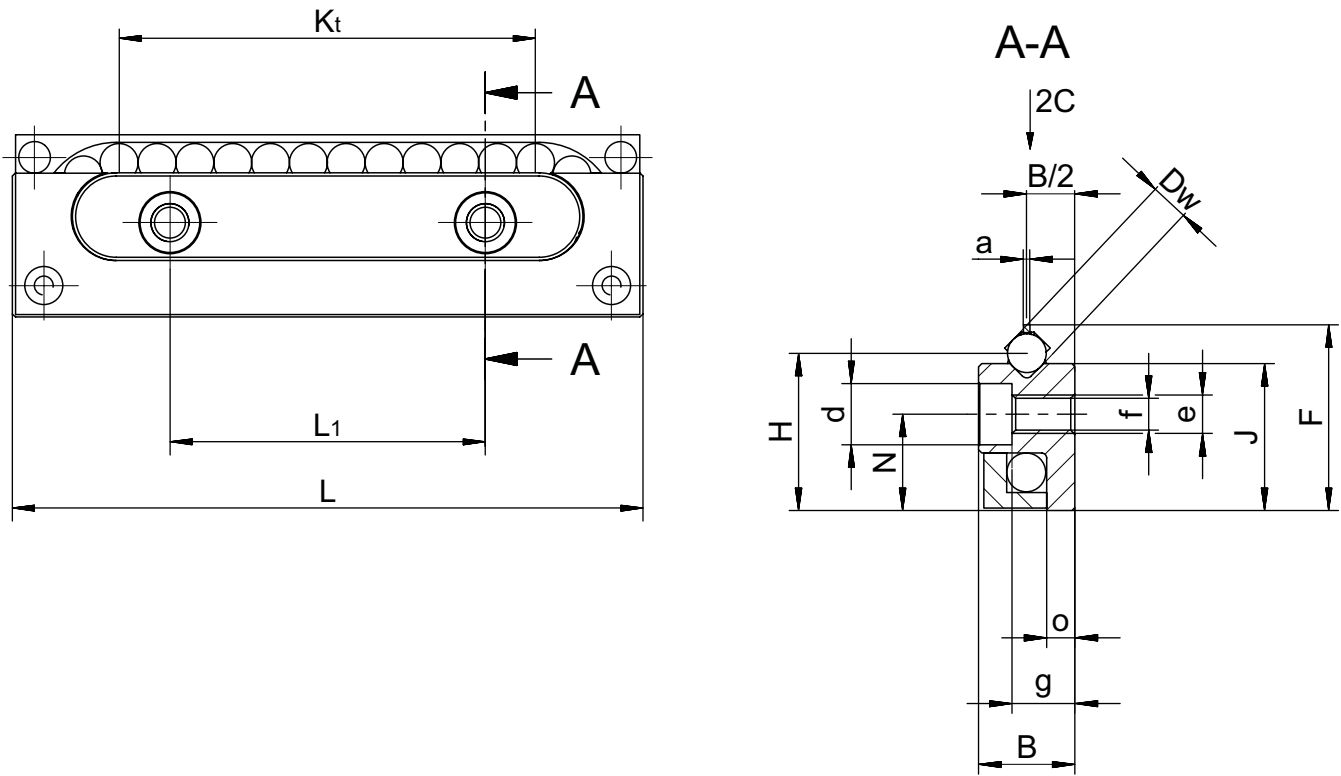

Type and size	Weight in g	B	Dw	F	H	J	$K_t$	L	$L_1$	N	a	d	e	f	g	o	C in N	Options (see chapter 8)
SKC 3-075	44	8	3	16.9	14.5	13.8	48	75	25	25	9	0.5	6	M4	3.3	4.9	2.4	75
SKC 6-100	212	15	6	28.9	24.5	22.9	60	100	50	50	15	1	9.5	M6	5.2	9.8	4.4	125

\* Loading capacity for dry running

## 6 Recirculating unit

### Installed dimensions and permissible torques for type SKC

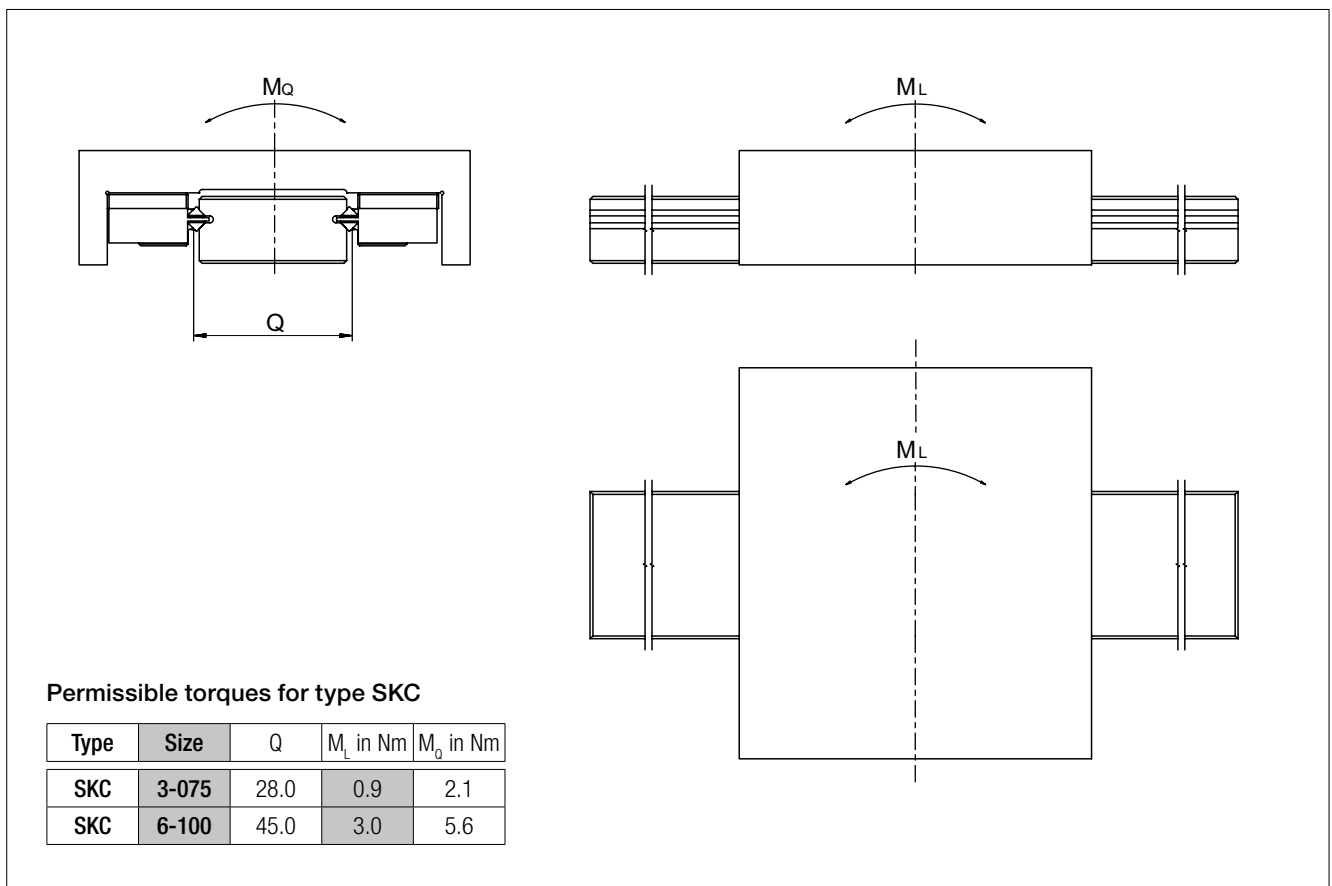
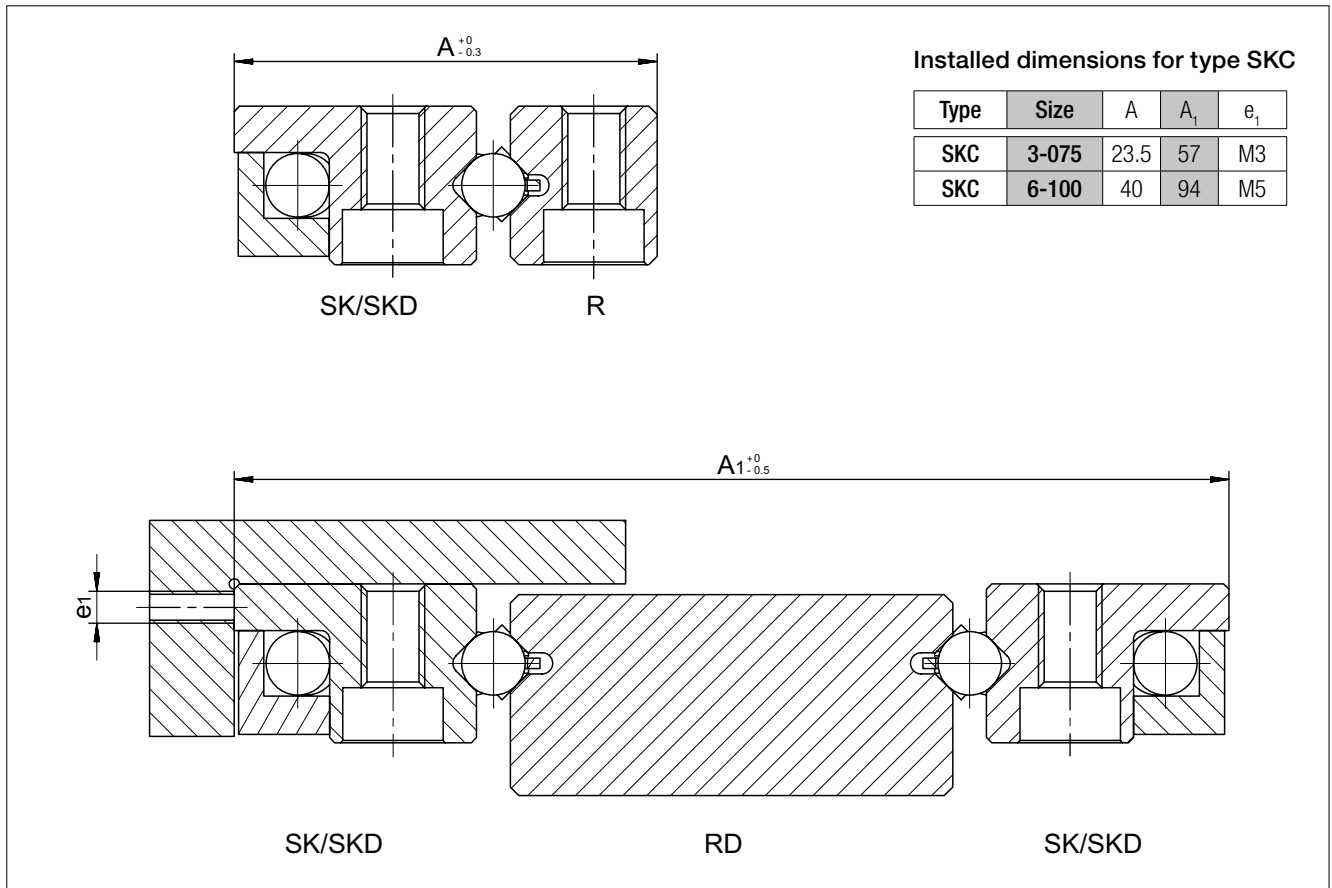

## 6 Recirculating unit

### 6.3 Type SR



The recirculating unit type SR has rollers arranged crosswise and is suitable for medium to high loads.

This recirculating unit is used combined with SCHNEEBERGER linear guideways of type R and/or RD. In this way space-saving designs can be created that can be equally loaded in all directions.

#### Benchmark data

Supporting structure

- Hardened and ground with high precision

Materials

- Supporting structure made of through hardened tool steel, hardness 58 - 62 HRC
- Rolling element made of through hardened roller bearing steel, hardness 58 - 64 HRC
- Transmission part depending on the length made of plastic or anodized aluminium
- Stainless steel on request
- From size 3 the rollers are laid in plastic shoes

Speed

- 2 m/s

Acceleration

- 50 m/s<sup>2</sup>

Operating temperatures

- -40° C to +80° C

Same installation with the following recirculating units

- SK, SKD and SKC

Can be combined with the following products

- Linear guideway type R and RD

## 6 Recirculating unit

### Dimensions and load capacities of type SR

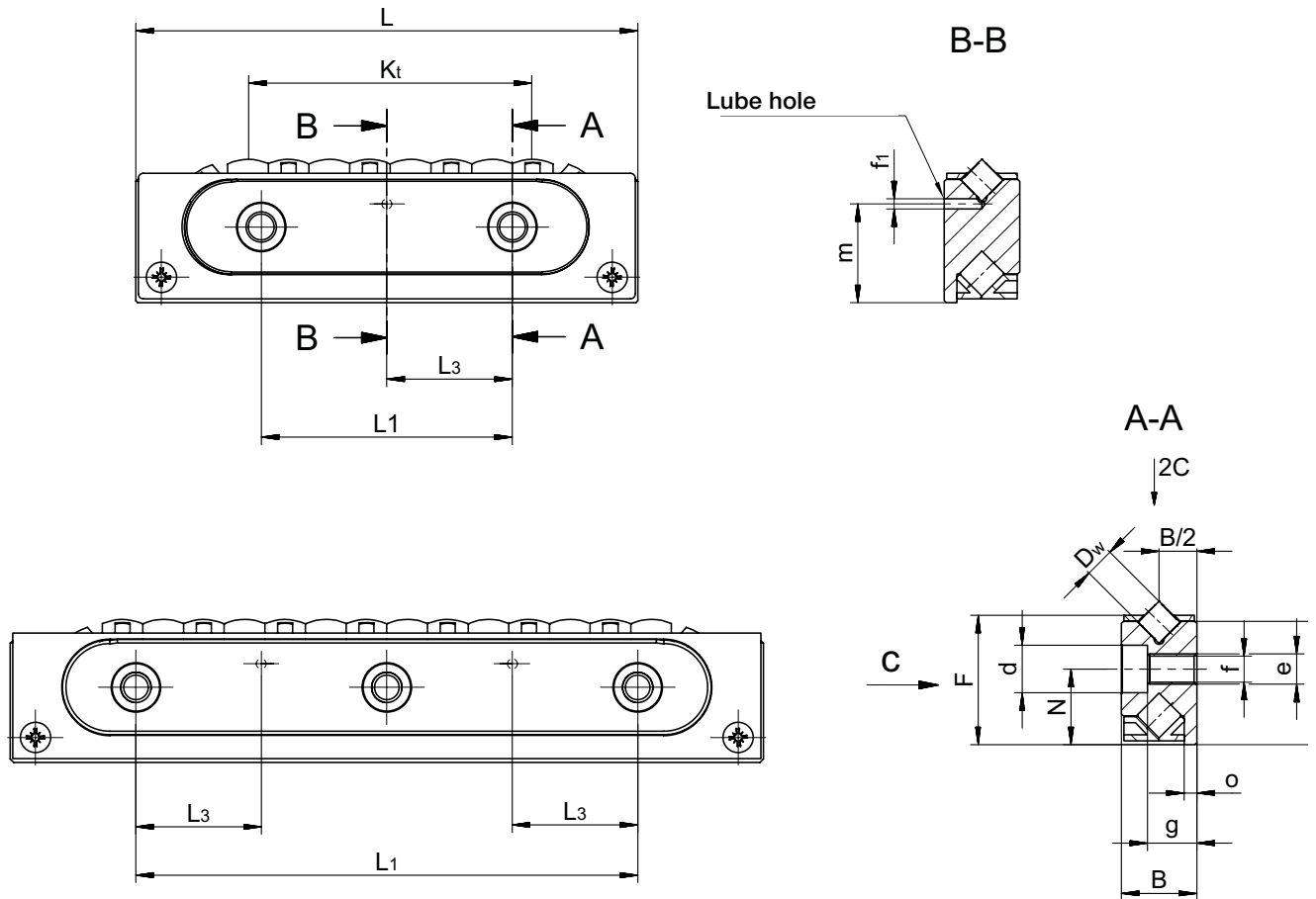

Type and size	Weight in g	B	Dw	F	J	K <sub>t</sub>	L	L <sub>1</sub>	L <sub>3</sub>	N	d	e	f	f <sub>1</sub>	g	m	o	C in N	Options (see chapter 8)
SR 2-032	10	6	2	9.8	9.5	16	32	15	-	6	4.4	M3	2.55	-	4	-	1	380	GP
SR 3-075	50	8	3	15	14.5	46	75	25	12.5	9	6	M4	3.3	1.5	4.9	11.8	1.3	850	GP
SR 6-100	210	15	6	25.7	24.5	56	100	50	25	15	9.5	M6	5.2	2	9.8	19.7	2.5	2'150	GP
SR 6-150	310					105	150	50										3'750	
SR 9-150	750	22	9	40.5	39	92	150	100	50	26	10.5	M8	6.8	3	15.8	32.4	3.5	5'850	GP
SR 12-200	1'580	28	12	51.5	49	112	200	100	50	32	13.5	M10	8.5	3	19.8	40.2	4	10'000	GP

The types in bold are standard. Type SR 12 is available on request

## 6 Recirculating unit

### Installed dimensions and permissible torques for type SR

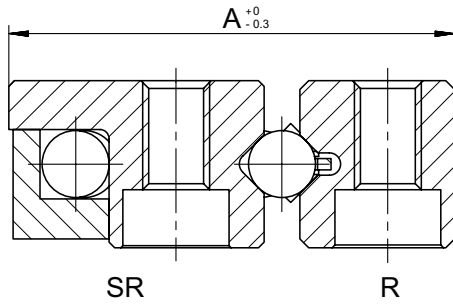

Installed dimensions for type SR

Type and size	A	A <sub>1</sub>	e <sub>1</sub>
<b>SR 2-032</b>	15.5	37	M2.5
<b>SR 3-075</b>	23.5	57	M3
<b>SR 6-100</b>	40	94	M5
<b>SR 6-150</b>	40	94	M5
<b>SR 9-150</b>	61	150	M6
SR 12-200	78	175	M8

The types in bold are standard. Type SR 12 is available on request

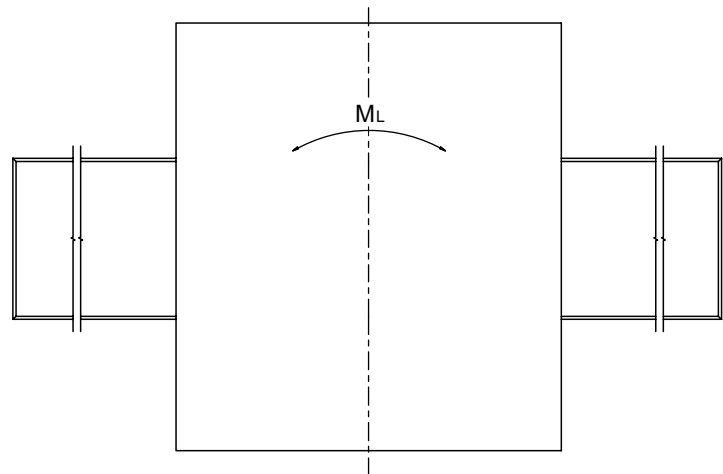
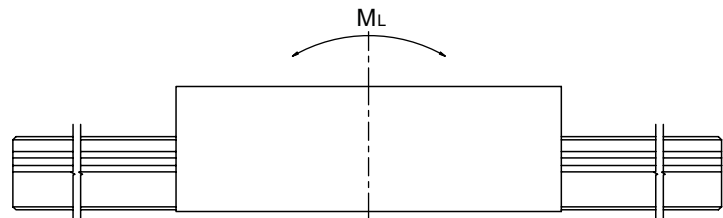
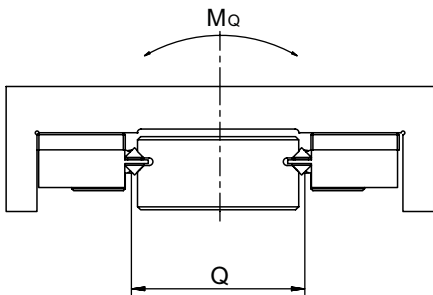
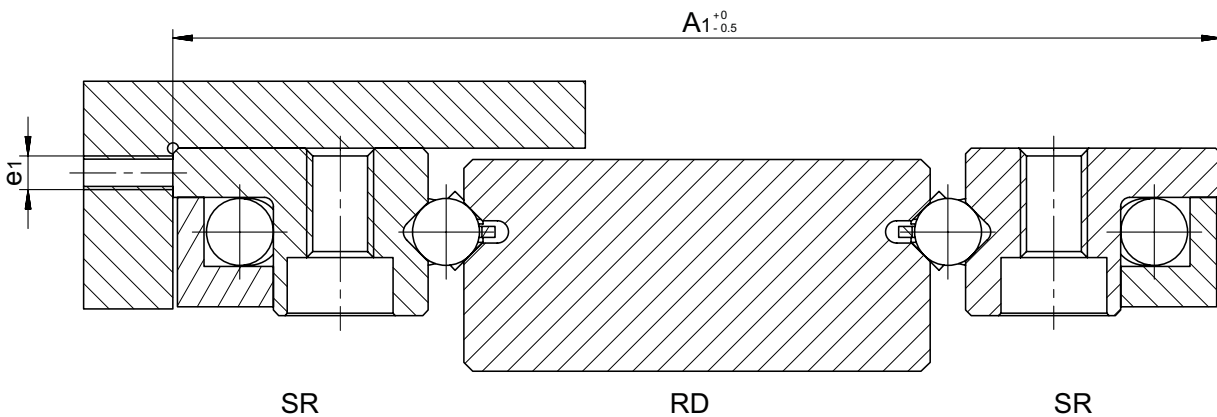

Torques for type SR

Type and size	Q	M <sub>L</sub> in Nm	M <sub>Q</sub> in Nm
<b>SR 2-032</b>	18.0	3.0	7.0
<b>SR 3-075</b>	28.0	12.0	24.0
<b>SR 6-100</b>	45.0	60.0	97.0
<b>SR 6-150</b>		112.0	169.0
<b>SR 9-150</b>	72.0	241.0	421.0
SR 12-200	77.0	553.0	770.0

The types in bold are standard. Type SR 12 is available on request

## 6 Recirculating unit

### 6.4 Type NRT (with NRV)



Recirculating unit type NRT

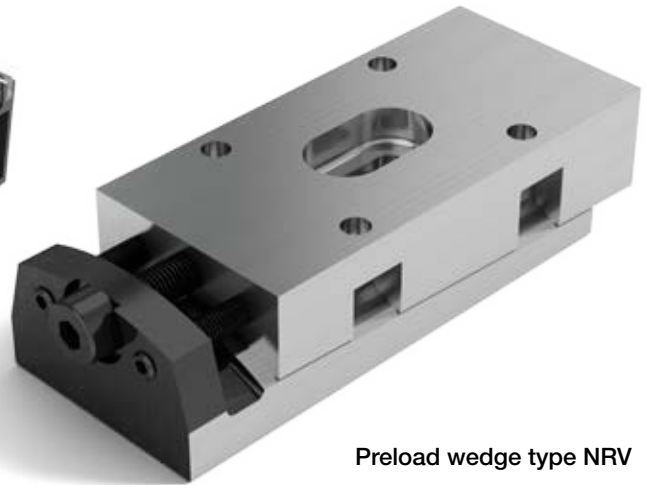

Preload wedge type NRV

This roller recirculating unit is designed for medium to heavy loads. Demanding solutions can be created together with the suitable linear guideways.

#### Advantages/benefits of the NRT

- Two independent tracks, the small amount of roller play and the optimal ratio of roller length and roller diameter are responsible for minimal lateral forces.
- The large number of rollers and the optimised roller run-ins are responsible for minimal travel pulsation and a low coefficient of rolling friction
- High degree of rigidity thanks to three-point support on the rear
- Protected roller return
- Double-lipped wipers on each side
- Can also be supplied matched as an option, sorted within 5µm

#### Advantages/benefits of the preload wedge NRV

This preload wedge is used for setting preload. The NRV with its concave and convex supporting surfaces is also able to even out minor angular errors and deformations in the connecting structure.

#### Benchmark data

##### Supporting structure

- Hardened and ground with high precision

##### Materials

- Supporting structure made of through hardened tool steel, hardness 58 - 62 HRC
- Rolling element made of through hardened roller bearing steel, hardness 58 - 64 HRC
- Transmission parts and wipers made of plastic

##### Speed

- 1 m/s

##### Acceleration

- 50 m/s<sup>2</sup>

##### Operating temperatures

- -40° C to +80° C



## 6 Recirculating unit

### Dimensions and load capacities of type NRT

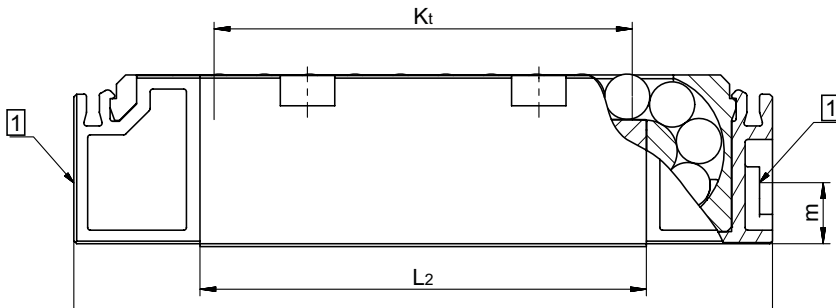
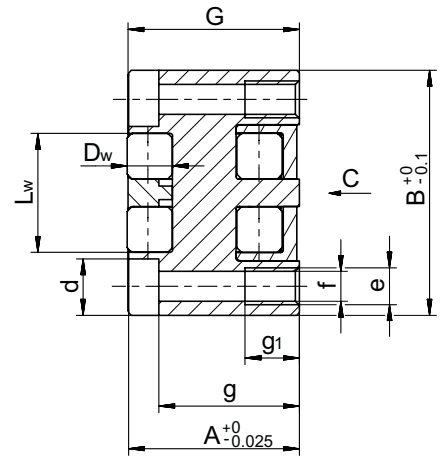
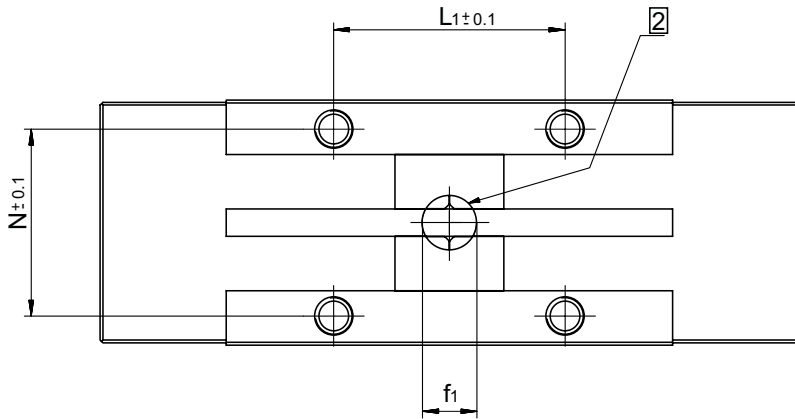

- 1 Double-sided lubrication opening with lube nipple
- 2  $\varnothing 4$  type D1a

### Recirculating unit type NRT

Type and size	Weight in g	A	B	Dw	G	K <sub>t</sub>	L	L <sub>1</sub>	L <sub>2</sub>	L <sub>w</sub>	N	d	e	f	f <sub>1</sub>	g	g <sub>1</sub>	m	C in N	Options (see chapter 8)
NRT 19077	185	19	27	5	18.85	45	77	25.5	49.2	13	20.6	6	M4	3.3	6	15.5	6	5.3	43'000	GP ZS
NRT 26111	570	26	40	7	25.85	70	111	44	75.6	19	30	8	M6	5	9	20	10	10.3	98'000	GP ZS
NRT 26132	721					91	132	68	96.6							20.6			120'000	GP ZS
NRT 38144	1'390	38	52	10	37.8	90	144	51	96.8	26	41	11	M8	6.8	11	29	14	14.5	181'000	GP ZS

## 6 Recirculating unit

### Dimensions and load capacities of type NRV

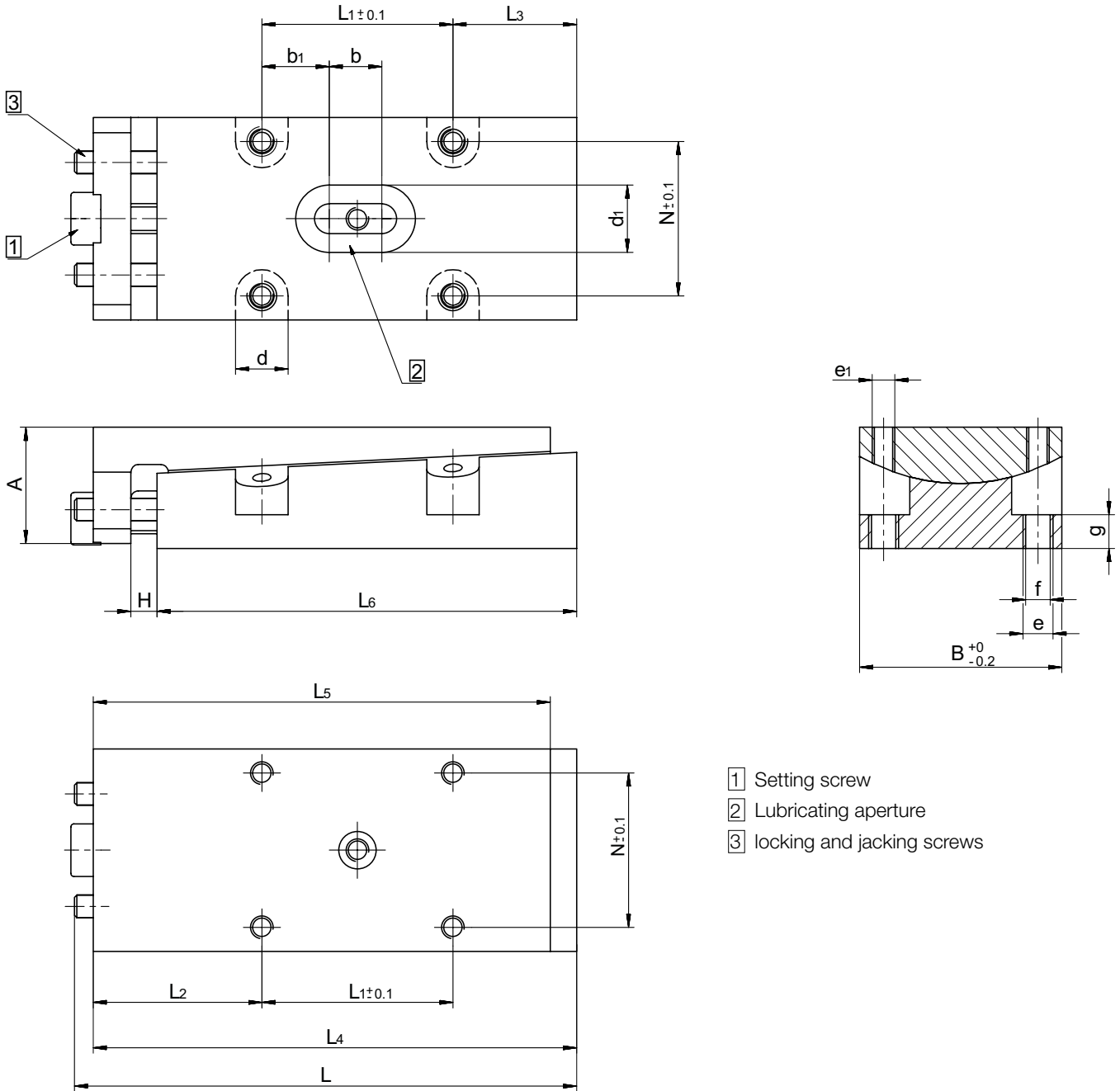

### Preload wedge NRV

Type and size	Weight in g	A	B	H max.	L max.	$L_1$	$L_2$	$L_3$	$L_4$ max.	$L_5$	$L_6$	N	b	$b_1$	d	$d_1$	e	$e_1$	f	g
NRT 19077	195	16	27	7	72	25.5	22.5	16.5	68	61	56	20.6	7	9	7	9	M4	M3	3.3	4.5
NRT 26111	670	25	40	8	105	44	29	21	98	90	83	30	9	17.5	8	11	M6	M4	5	8
NRT 26132	837				126	68	27.5	19.5	119	111	104			29.5						
NRT 38144	1'300	30	52	8	130	51	37.5	28.5	121	113	105	41	10	20.5	11	14	M8	M6	6.8	8



## 7 Options for linear guideways

### 7.1 Quality classes (SQ and SSQ)

Depending upon the application different levels of accuracy are required. SCHNEEBERGER linear guideways can be supplied in three quality classes:

NQ*	Normal quality	Represents normal requirements in mechanical engineering
SQ	Special quality	In case of very stringent requirements
SSQ	Super special quality	In case of the most stringent requirements

Note:

\*NQ represents standard quality and is not subsequently listed as an order code

The corresponding tolerance values ( $\Delta$ ) for parallelism of the running surfaces in relation to the reference and locating surfaces can be seen in the diagram below.

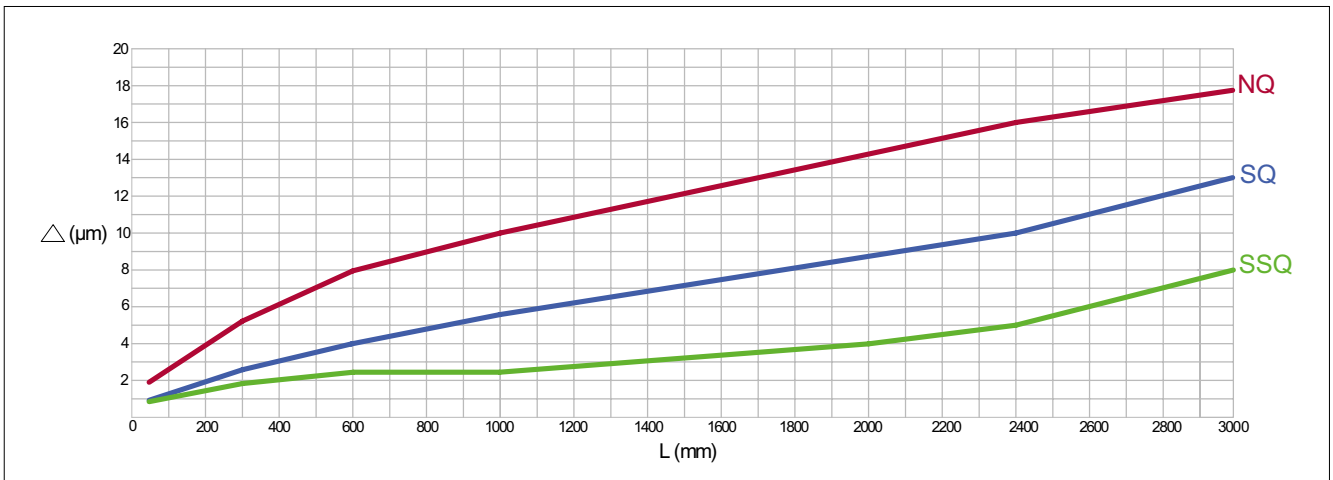

In terms of the quality classes SQ and SSQ the following limitations technically exist:

- Max. lengths according to the table "Dimensions and load capacities" of the respective product.
- Coatings (see chapter 7.6 and 7.7)

### 7.2 Guideways made of corrosion-resistant steel (RF)

For certain applications such as, for example, medical technology, food industry or in a vacuum, the guide rails can be made of corrosion-resistant steel.

Notes:

- The max. rail length in normal quality as well as in options SQ and SSQ is limited (see "dimensions and load capacities" of the respective product).
- The hardness of the steel reduces compared with tool steel to min. 54 HRC, which should be taken into account in the food calculation.

## 7 Options for linear guideways

### 7.3 Run-ins rounded (EG)

Overrunning cages are expedient if a short table is to be moved on a long guideway track. As a result the upper part is at any time supported over its entire length, which has a positive effect on the load carrying capacity and rigidity.

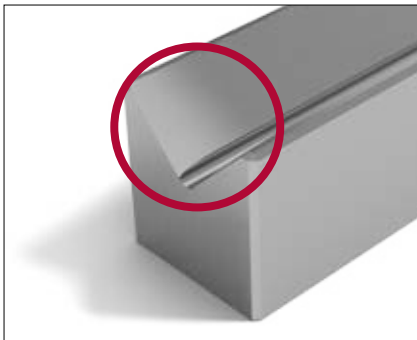
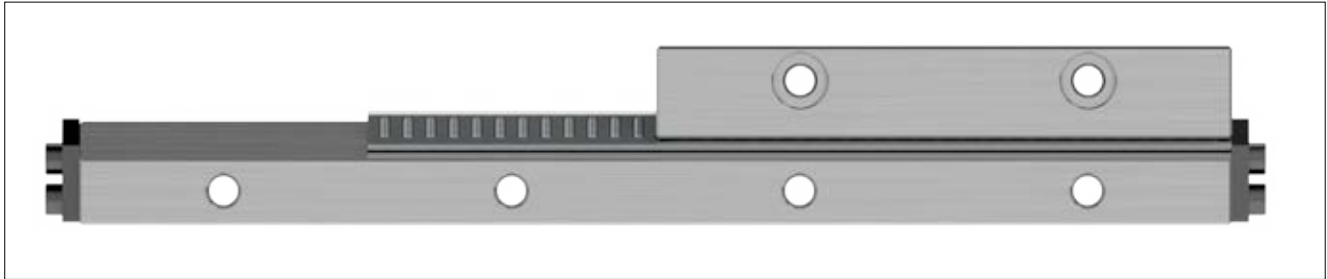

SO that the cage run-in causes as little pulsation as possible, the short rails are provided with rounded run-ins. The run-ins are ground following manufacture of the guideway track.

Note:

On rare occasions (e.g. under very high preload), in spite of rounded run-ins the pulsation of the overrunning cage can have a disruptive effect on the application. This phenomenon can be largely eliminated by taking appropriate measures (on request).

### 7.4 Multi-part linear guideways (ZG)

Is the desired overall length of the guideway is greater than the maximum length listed in this catalogue, individual rails can be ground together. The offset between the individual guideway tracks for this is max. 0.002 mm. The length tolerance L is within +/- 2 mm.

During installation it is important to pay attention to the numbering at the butt joint.

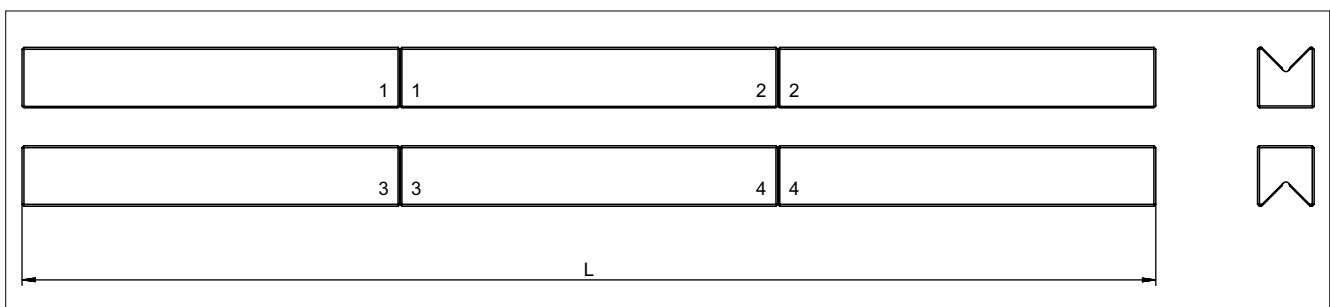

## 7 Options for linear guideways

### 7.5 Height-matched guideways (HA)

The tolerance of height A is as standard 0/-0.3 mm. In the case of surface-mounted guideways, which must be matched to the same height, A (and/or A1 and A2) is made in consignments with a tolerance of +/- 0.01 mm.

The rails are identified/numbered correspondingly. If multiple consignments are supplied, they are given serial numbers.

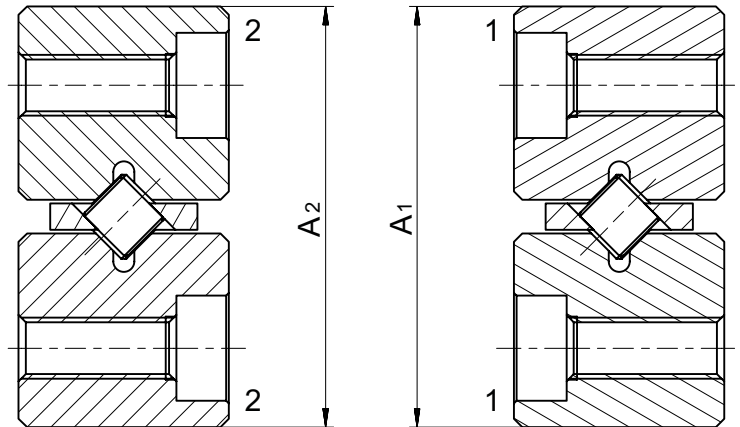

### 7.6 DURALLOY® coating (DU)

For applications in which a corrosion protection and/or increased wear resistance of the surfaces is required, it is recommended to coat the guideways with DURALLOY®.

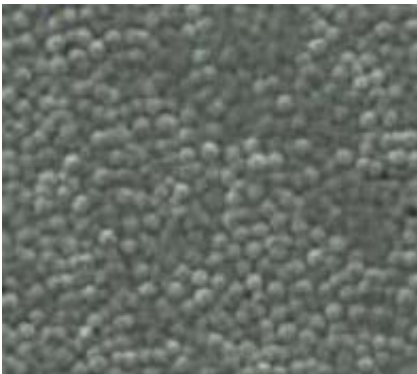

#### Technical information

- Max. rail length 2000 mm
- Hardness HRC 64 - 74
- Coating thickness 2.5 - 4.0 µm
- Structure "Pearlescent" (see figure)
- Vacuum-compatible 10<sup>-7</sup> mbar

#### The advantages of DURALLOY®

- Increased wear resistance
- Corrosion protection
- The pearl structure acts as a lubricant reservoir
- Good emergency running characteristics
- Protection from abrasive corrosion
- High degree of chemical resistance

#### Notes:

- The ZG special versions (multi-part linear guideway) and the maximum quality grade SSQ are not possible.
- Special quality SQ only on request

## 7 Options for linear guideways

### 7.7 DryRunner coating (DR and DRC1)

Without lubrication the running surfaces of linear guideways are completely destroyed after only 10'000 passes.

A guideway coated with DryRunner supports more than 100 million passes and thus a service life extended by 10'000 times - without lubrication. In vacuum an unlubricated guideway coated with DryRunner supports more than 50 million passes.

DryRunner coated linear guideways can of course be used with standard lubricants, which means the previously listed running performance statistics increase considerably.

#### Technical information

Area of use	Order code	Film thickness	Max. length of the guideway
Air	DR	1.5–3.0 µm	900 mm
Vacuum (up to 10 <sup>-7</sup> mbar)	DRC1	1.0–2.0 µm	380 mm

- The coating is only applied to the running surfaces. From a production technology standpoint, it is possible that other exterior surfaces are coated; but not the supporting and locating surface of the guideway.
- DryRunner does not provide any protection against corrosion. If corrosion resistance is required, the guideway must be ordered in a non-corrosive material.

#### The advantages of DryRunner

- Supports dry running
- Suitable for applications in air or vacuum
- Minimal wear as a result of abrasion

#### Notes

- DryRunner supports operation without a lubricant, which is why we recommend the use of the cage control FORMULA-S (KS) option (see chapter 7.8).
- The special versions of multi-part linear guideways ZG and the quality class SSQ are not possible. Quality class SQ on request (see chapter 7.4 and 7.1).

## 7 Options for linear guideways

### 7.8 Cage control FORMULA-S (KS)

In every linear guideway the cage can be shifted from the centre along the longitudinal axis. This so-called «cage creep» can significantly impair the effectiveness of your application. On the one hand, as a result of the displaced cage the optimal load distribution is no longer guaranteed and, on the other, the cage must be centred with huge expense of energy (correction stroke).



#### The causes of cage creep

- High accelerations and speeds
- Vertical installation of the guideway
- Uneven load distribution
- Overrunning cage
- Different heat expansion coefficients
- Design and installation (lacking rigidity and/or accuracy of the connecting structure)

#### The benefits and advantages of FORMULA-S

- Perfect load distribution
- Avoids correction strokes
- No force required for cage reset
- Accelerations up to  $300 \text{ m/s}^2$  (30 g)
- Max speed 1 m/s
- Easy to install and/or uninstall
- Extended service life
- Vacuum-compatible up to  $10^{-7}$  mbar

#### Suitable for the following guideways

- RN 3, RN 4 and RN 6
- RNG 4, RNG 6 and RNG 9

FORMULA-S meets the requirements fully in respect of productivity and cost-effectiveness. It is very robust and consists of only a few components.

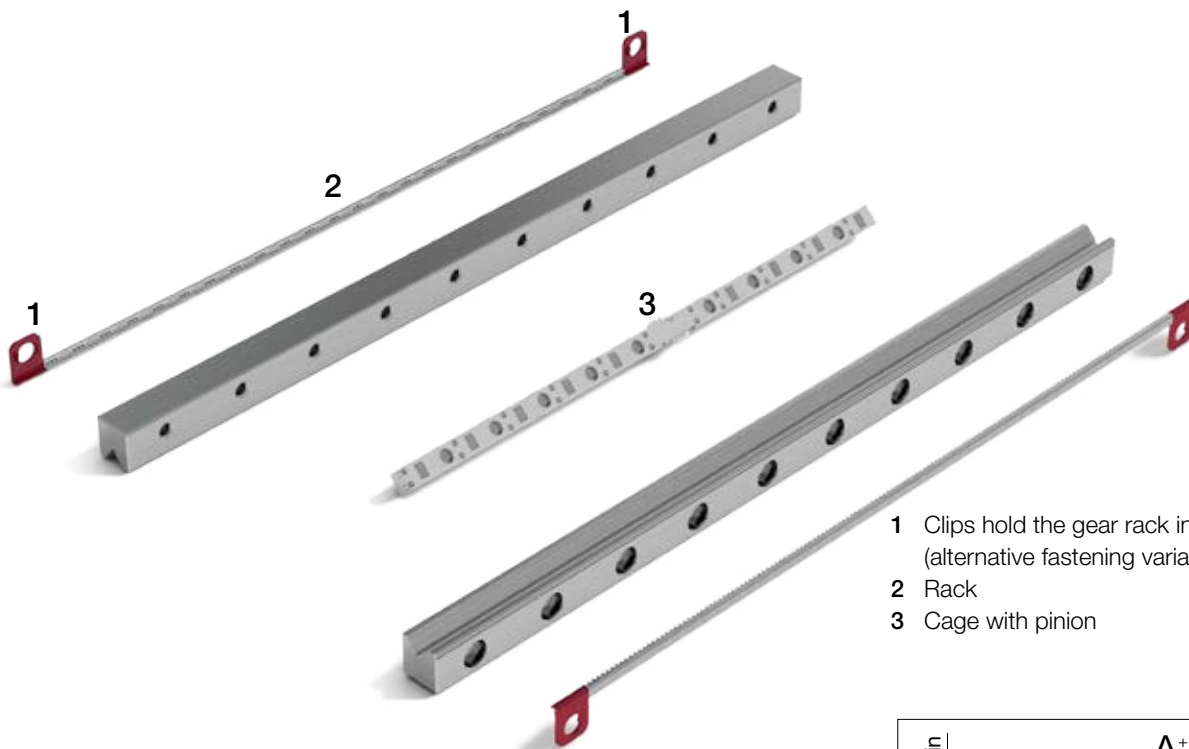

- 1 Clips hold the gear rack in position (alternative fastening variants on request)
- 2 Rack
- 3 Cage with pinion

#### Connecting structure

In the case of the connecting structure, the thickness  $s_{\min}$  should be taken into account. The remaining dimensions correspond to the guideways RN and RNG (see chapter 5, dimensions and load capacities).

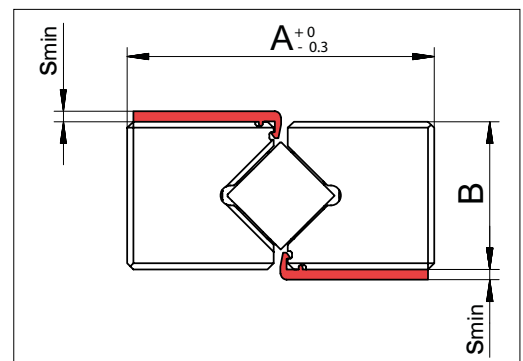

Sold & Serviced By:

**ELECTROMATE**

Toll Free Phone (877) SERV098  
Toll Free Fax (877) SERV099  
www.electromate.com  
sales@electromate.com



## 7 Options for linear guideways

### 7.9 Cage control for N/O and M/V guideways (KZST)



The needle guideways of type N/O and M/V can be fitted with a cage control which ensures that process security is significantly increased. The causes and effects of cage creep are set out in chapter 7.8.

#### The benefits and advantages

- Perfect load distribution
- Avoids correction strokes
- No force required for cage reset
- Accelerations up to  $200 \text{ m/s}^2$  (20 g)
- Max. speed 1 m/s
- Extended service life

This type of cage control fully meets the requirements in terms of productivity and cost-effectiveness. It is very robust, has a simple structure and consists of only a few components:

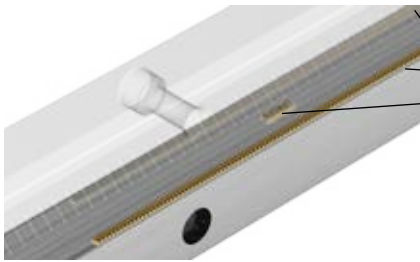

- A** A gear rack made of tool steel per guide rail
- B** Two pinions made of tool steel per cage

### 7.10 Fixing Hole Variants (V, G, or D)

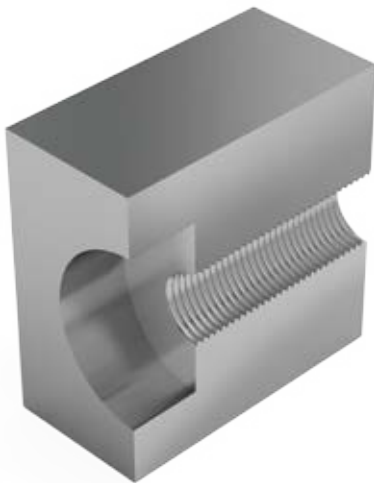

#### **The SCHNEEBERGER standard**

All SCHNEEBERGER guideways have as standard a counterbore with thread (not suitable for linear guideways of type M/V). This design supports the use of a tapped fixing hole as well as the through fixing hole. The dimensions can be seen in the respective product specifications (chapter 5).

## 7 Options for linear guideways

Special versions type V (standard for linear guideway of type M/V)

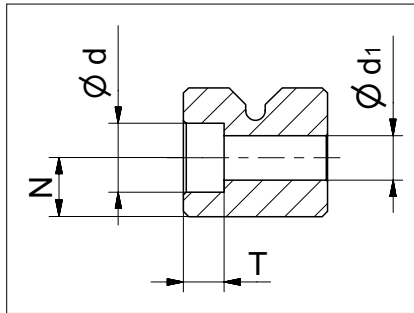

### Dimensions for R-guideways

Type	N	Ø d	T	Ø d <sub>1</sub>
R 1	1.8	3	1.4	1.65
R 2	2.5	4.4	2	2.55
R 3	3.5	6	3.2	3.5
R 6	6	9.5	5.2	5.5
R 9	9	10.5	6.2	6.5
R 12	12	13.5	8.2	8.5
R 15	14	16.5	10.2	10.5
R 18	18	18.5	12.2	12.5
R 24	24	22.5	14.2	14.5

### Dimensions for RN-guideways

Type	N	Ø d	T	Ø d <sub>1</sub>
RN 3	3.5	6	3.2	3.5
RN 4	4.5	8	4.1	4.5
RN 6	6	9.5	5.2	5.5
RN 9	9	10.5	6.2	6.5
RN 12	12	13.5	8.2	8.5
RN 15	14	16.5	10.2	10.5
RN 18	18	18.5	12.2	12.5
RN 24	24	22.5	14.2	14.5

### Dimensions for RNG-guideways

Type	N	Ø d	T	Ø d <sub>1</sub>
RNG 4	3.5	5.5	2.7	3.5
RNG 6	5	7	3.2	4
RNG 9	6	8.5	4.2	4.8
RNG 12	8	12	6.2	7
RNG 15	10	15	8.2	9
RNG 20	12	18	11	10.5

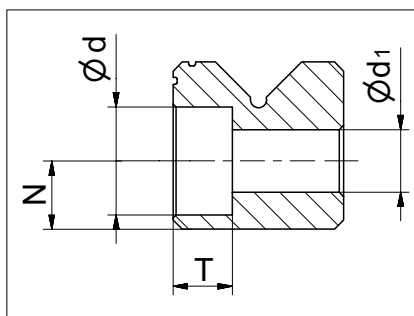

### Dimensions for RNG guideways with a cage control system (KS)

Type	N	Ø d	T	Ø d <sub>1</sub>
RNG 4-KS	3.5	6	3.2	3.5
RNG 6-KS	5	7.8	3.5	4
RNG 9-KS	6	8.5	4.2	4.8

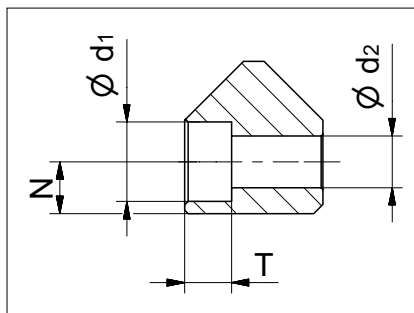
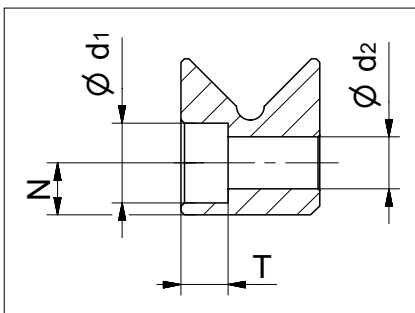

### Dimensions for N/O-guideways

Type	N	Ø d <sub>1</sub>	T	Ø d <sub>2</sub>
N/O 62015	6	9.5	5.2	5.5
N/O 92025	9	10.5	6.2	6.5
N/O 2025	10	13.5	8.2	8.5
N/O 2535	12	16.5	10.2	10.5
N/O 3045	14	18.5	12.2	12.5
N/O 3555	14	18.5	12.2	12.5

## 7 Options for linear guideways

### Special versions type G

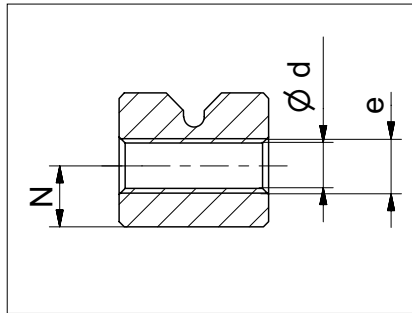

#### Dimensions for R-guideways

Type	N	e	Ø d
R 1	1.8	M2	1.65
R 2	2.5	M3	2.55
R 3	3.5	M4	3.3
R 6	6	M6	5.2
R 9	9	M8	6.8
R 12	12	M10	8.5
R 15	14	M12	10.5
R 18	18	M14	12.5
R 24	24	M16	14.5

#### Dimensions for RN-guideways

Type	N	e	Ø d
RN 3	3.5	M4	3.3
RN 4	4.5	M5	4.3
RN 6	6	M6	5.2
RN 9	9	M8	6.8
RN 12	12	M10	8.5
RN 15	14	M12	10.5
RN 18	18	M14	12.5
RN 24	24	M16	14.5

#### Dimensions for RNG-guideways

Type	N	e	Ø d
RNG 4	3.5	M3	2.65
RNG 6	5	M4	3.3
RNG 9	6	M5	4.4
RNG 12	8	M8	6.8
RNG 15	10	M10	8.5
RNG 20	12	M12	10.5

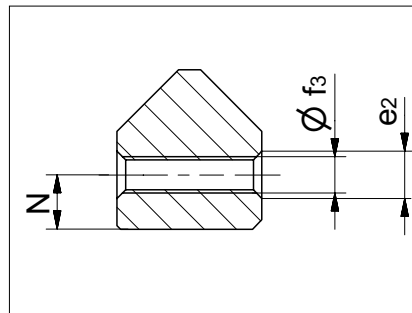
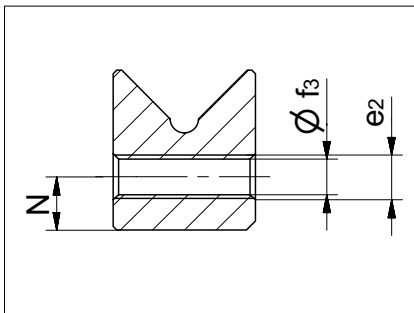

#### Dimensions for N/O-guideways

Type	N	e <sub>2</sub>	Ø f <sub>3</sub>
N/O 62015	6	M6	5.2
N/O 92025	9	M8	6.8
N/O 2025	10	M10	8.5
N/O 2535	12	M12	10.5
N/O 3045	14	M14	12.5
N/O 3555	14	M14	12.5

## 7 Options for linear guideways

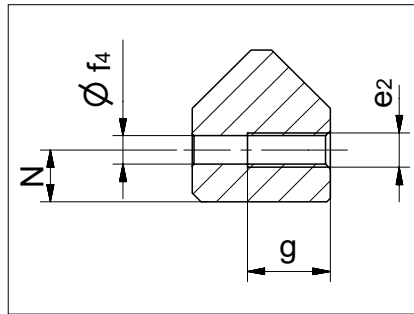
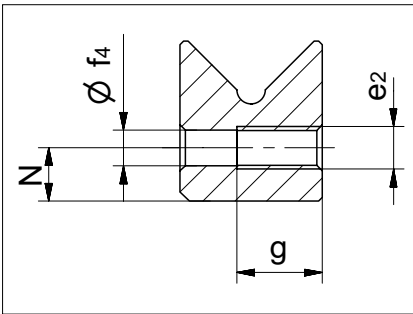
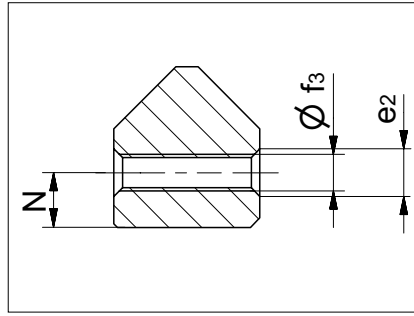
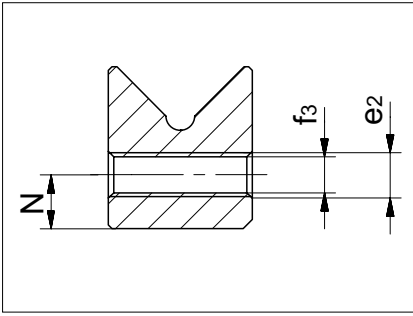

Dimensions for M/V-guideways

Type	N	e <sub>2</sub>	g	∅ f <sub>3</sub>	∅ f <sub>4</sub>
M/V 3015	5.5	M4	-	3.2	-
M/V 4020	7.5	M6	-	5.2	-
M/V 5025	10	M6	15	5.2	5
M/V 6035	11	M8	20	6.8	6.8
M/V 7040	13	M10	25	8.5	8.5
M/V 8050	14	M12	30	10.5	10.3

## 7 Options for linear guideways

### Special versions type D

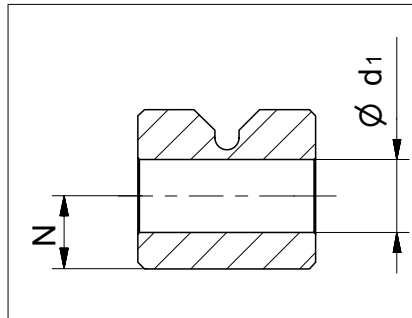

#### Dimensions for R-guideways

Type	N	Ø d <sub>1</sub>
R 1	1.8	1.65
R 2	2.5	2.55
R 3	3.5	3.5
R 6	6	5.5
R 9	9	6.5
R 12	12	8.5
R 15	14	10.5
R 18	18	12.5
R 24	24	14.5

#### Dimensions for RN-guideways

Type	N	Ø d <sub>1</sub>
RN 3	3.5	3.5
RN 4	4.5	4.5
RN 6	6	5.5
RN 9	9	6.5
RN 12	12	8.5
RN 15	14	10.5
RN 18	18	12.5
RN 24	24	14.5

#### Dimensions for RNG-guideways

Type	N	Ø d <sub>1</sub>
RNG 4	3.5	3.5
RNG 6	5	4
RNG 9	6	4.8
RNG 12	8	7
RNG 15	10	9
RNG 20	12	10.5

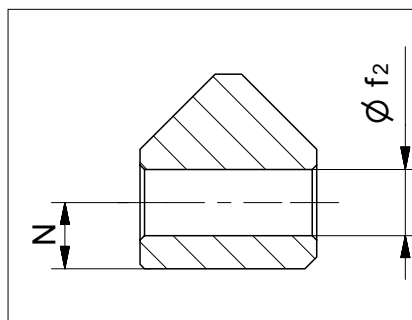
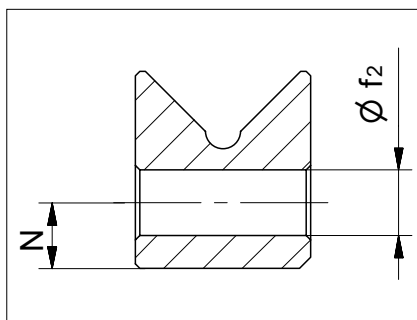

#### Dimensions for N/O-guideways

Type	N	Ø f <sub>2</sub>
N/O 62015	6	5.5
N/O 92025	9	6.5
N/O 2025	10	8.5
N/O 2535	12	10.5
N/O 3045	14	12.5
N/O 3555	14	12.5

#### Dimensions for M/V-guideways

Type	N	Ø f <sub>2</sub>
M/V 3015	5.5	5.3
M/V 4020	7.5	7.5
M/V 5025	10	7.5
M/V 6035	11	10
M/V 7040	13	12.5
M/V 8050	14	14

## 8 Recirculating unit options

### 8.1 Matched recirculating units (GP)

If two or more recirculating units are arranged next to or behind one another, they need to be ordered (matched in pairs) with the add-on designation GP.

SK, SKD, SKC, SR

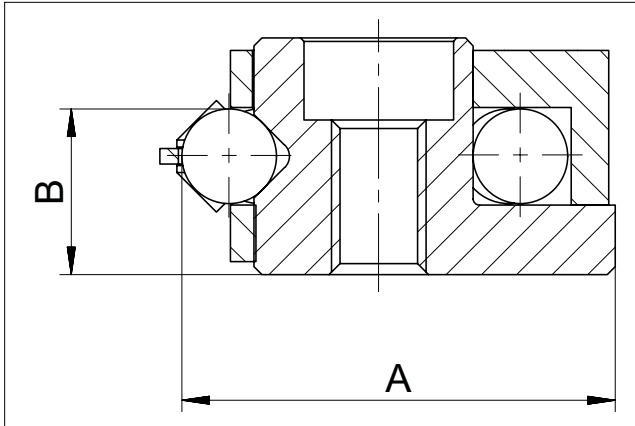

Type	Manufacturing tolerances in mm		Group tolerances in $\mu\text{m}$ within pairs	
	A	B	A	B
<b>SK 1, 2</b>	0/-0.1	+/-0.005	2	2
<b>SK 3, 6, 9, 12</b>	0/-0.1	+/-0.005	3	3
<b>SKD 6, 9, 12</b>	0/-0.1	+/-0.005	3	3
<b>SKC 6, 9</b>	0/-0.1	+/-0.005	3	3
<b>SR 2</b>	0/-0.1	+/-0.005	2	2
<b>SR 3, 6, 9, 12</b>	0/-0.1	+/-0.005	3	3

The types in bold are standard. The types in size 12 are available on request

Markings:

The recirculating units in the same group are designated with a number, i.e. the same number corresponds to the exact same tolerance group.

NRT

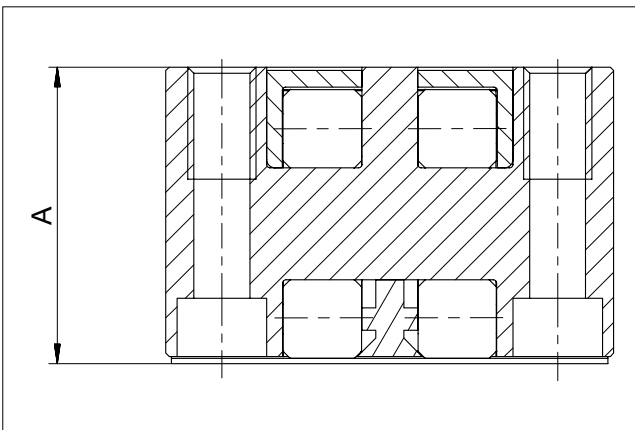

Type	Manufacturing tolerance A	Sorts in $\mu\text{m}$	Markings
NRT	-0.025	-20 to -25	white
		-15 to -20	green
		-10 to -15	yellow
		-5 to -10	blue
		0 to -5	red

Markings:

Coloured rings around the lube nipple mark the relevant tolerance group.



## 8 Recirculating unit options

### 8.2 Centralised lubricating system (ZS) for recirculating units NRT

#### Connection variants

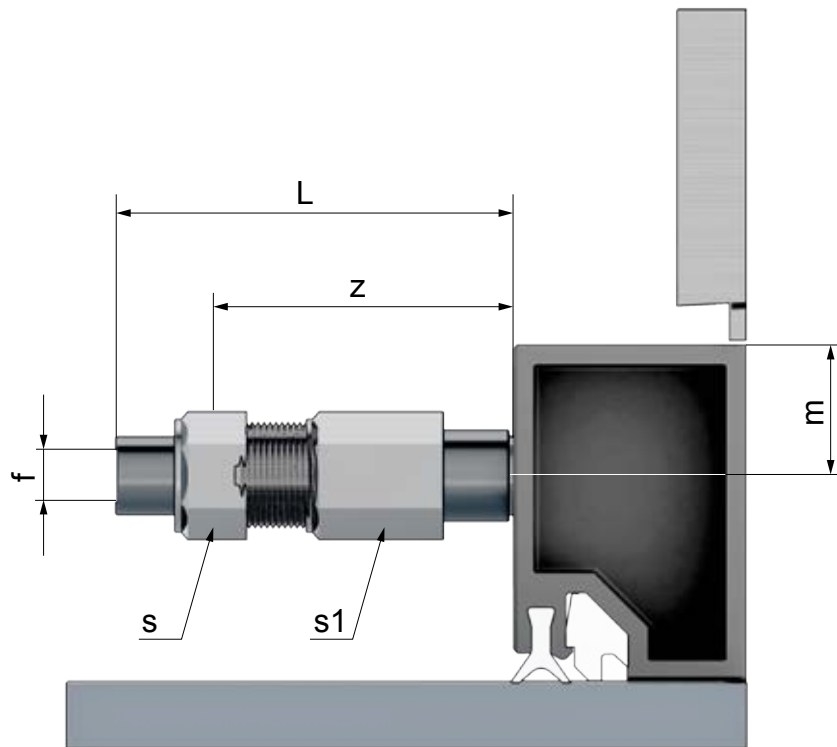

Type	Size	L	f	m	Wrench size		z
					s	s1	
NRT 19077	ZS-2	13	2	5.3	8	7	10.5
	ZS-3	14.5	3		8	7	11
NRT 26111 NRT 26132	ZS-2	13	2	10.3	8	7	10.5
	ZS-3	14.5	3		8	7	11
	ZS-4	18.5	4		10	8	14
	ZS-5	19	5		12	10	
NRT 38144	ZS-2	13	2	14.5	8	7	10.5
	ZS-3	14.5	3		8	7	11
	ZS-4	18.5	4		10	8	14
	ZS-5	19	5		12	10	
	ZS-6	20	6		12	10	

## 9 Linear guideways standard parameters

### 9.1 Quality classes

The running and positioning accuracy of an application directly depends on the geometric precision of the guideway (see chapter 7.1), its careful orientation (see chapter 14.9) and the accuracy and rigidity of the surrounding structure (see chapter 14.1 / 14.2).

### 9.2 Tolerance of the supporting surface to the track

In addition to the previously mentioned geometric precision as set out in chapter 7.1, SCHNEEBERGER guideways are also manufactured to the dimensions of the supporting surface in relation to the track within a very tight tolerance ( $\pm 0.005\text{mm}$ ).

Its advantages:

- Interchangeability is guaranteed at all times.
- In most cases additional matching of the guideways is surplus to requirement.

Type R, RN and RNG

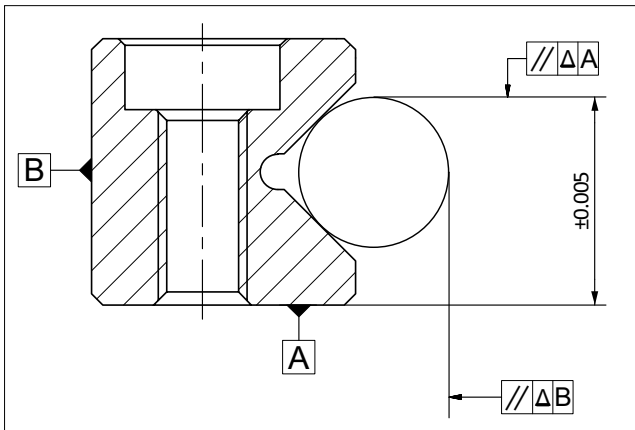

Type RD

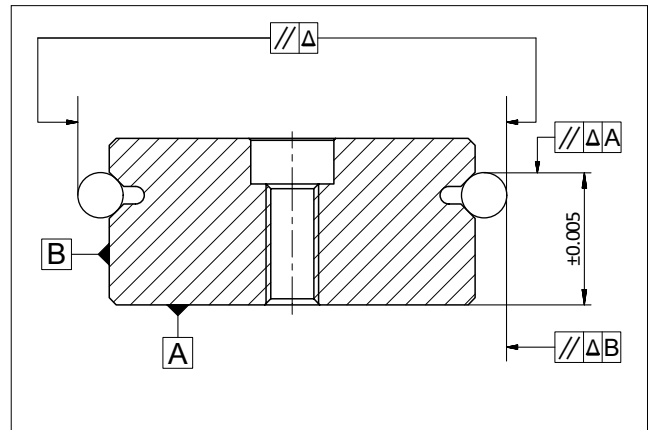

Type N/O and M/V

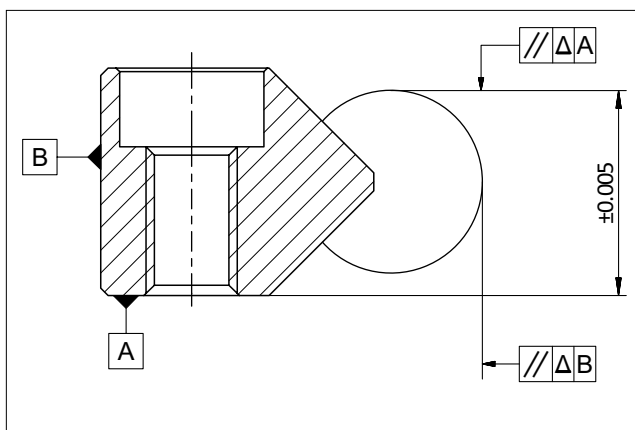



## 9 Linear guideways standard parameters

### 9.3 Length tolerances and distances between fixing holes

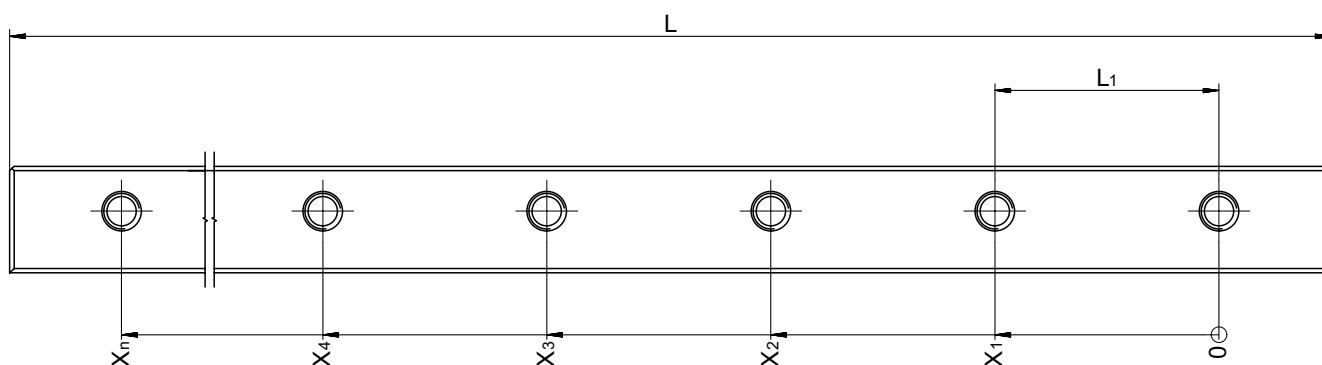

Length	L ≤ 300 mm:	±0.3 mm
Length	L > 300 mm:	±0.1 % of L
Hole pitch	L <sub>1</sub> :	±0.3 mm
Mass	X <sub>n</sub> ≤ 350 mm:	±0.3 mm
Mass	X <sub>n</sub> > 350 mm:	±0.08 % of x <sub>n</sub>

The fixing holes are manufactured before the hardening process, which is why the length tolerances and spacings differ from the usual standards. The deviations can be offset using undercut fastening screws of type GD or GDN (see chapter 5) and/or by choosing a suitable hole (see chapter 7.10).

### 9.4 Operating temperatures

SCHNEEBERGER linear guideways can be used at operating temperatures from -40° C to +80° C. For brief periods temperatures up to +120° C are possible.

### 9.5 Speeds and accelerations

The following limit values apply for the standard designs:

Product	max. speed	max. acceleration
Linear guideways R, RD, RN, RNG, N/O and M/V	1 m/s	50 m/s <sup>2</sup>
Linear guideways RN and RNG with Cage control FORMULA-S	3 m/s	300 m/s <sup>2</sup>
Linear guideways N/O and M/V with cage control	3 m/s	200 m/s <sup>2</sup>

### 9.6 Friction, running accuracy and smoothness

When manufacturing the linear guideways, SCHNEEBERGER places great value on a high level of smoothness. Transitions, run-ins and run-outs or the quality of the synthetic materials and synthetic composite cages are given top priority. This also applies in respect of the rolling elements used, which must satisfy the most stringent quality demands.

For guideways with cages under normal operating conditions a friction factor of 0.0005 to 0.0030 can be assumed.

## 10 Recirculating unit standard parameters

### 10.1 Operating temperatures

SCHNEEBERGER recirculating units can be used at operating temperatures from  $-40^{\circ}\text{C}$  to  $+80^{\circ}\text{C}$  (for brief periods temperatures up to  $+120^{\circ}\text{C}$  are possible). For type SKC the temperature range is  $-150^{\circ}\text{C}$  to  $+200^{\circ}\text{C}$ .

### 10.2 Speeds and accelerations

The following limit values apply for the standard designs:

Product	max. speed	max. acceleration
SK, SKD, SKC and SR	2 m/s	50 m/s <sup>2</sup>
NRT	1 m/s	50 m/s <sup>2</sup>

### 10.3 Friction, running accuracy and smoothness

When manufacturing the recirculating units, SCHNEEBERGER places great value on a high level of smoothness. Transitions, run-ins and run-outs or the quality of the synthetic materials are given top priority. This also applies in respect of the rolling elements used, which must satisfy the most stringent quality demands.

For recirculating units under normal operating conditions a friction factor of 0.005 can be assumed.

The versatile areas of application assume different characteristics from linear guideways and recirculating units. Various parameters and considerations essential for product selection. These are set out in detail below.

## 11.1 Linear guideways

### Relationship between stroke H and length of the guideway L

If the stroke is below 400 mm, the following formula applies:

$$\frac{H}{L} \leq 0.7$$

If the stroke is above 400 mm, the following formula applies:

$$\frac{H}{L} \leq 1$$

L = Length of the linear guideway in mm  
H = Stroke in mm

### Calculating the cage length K

$$K \leq L - \frac{H}{2}$$

K = Cage length in mm  
L = Length of the linear guideway in mm  
H = Stroke in mm

The stroke must be limited by means of stops on the table and not by the cages. The stops should preferably be fitted along the axis of symmetry of the guideways to avoid additional forces acting on the linear guideways.

### Calculating the number of rolling elements (R<sub>A</sub>) per cage

a) For cage types KBN, AC, AK, EE, SHW, HW

$$R_A = \frac{K - 2w}{t} + 1$$

or

$$R_A = \frac{K_t}{t} + 1$$

b) For cage type KBS

$$R_A = \frac{K - (2w + t_z)}{t} + 2$$

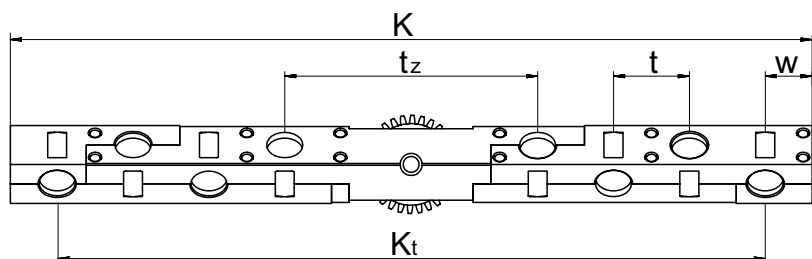

K = Cage length in mm  
R<sub>A</sub> = Total available rolling element per cage  
w = Distance from cage start to the middle of the first rolling element in mm  
t = cage division in mm  
K<sub>t</sub> = Load-bearing length in mm  
t<sub>z</sub> = Length of the middle section for the KBS cage

# 11 Design

The relationship between the cage length K and the average guideway spacing Q

$$\frac{K}{Q} \geq 1$$

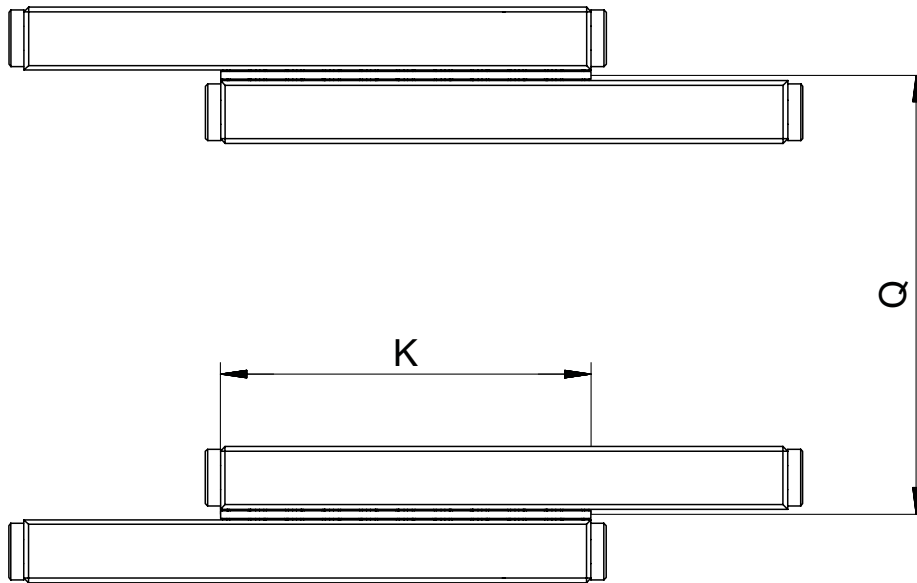

<p>K = Cage length in mm Q = Average linear guideway spacing in mm</p>
--

The maximum permissible installation ratio in the case of overrunning cages

Overrunning cages are expedient if a short table is to be moved on a long guideway track. In each case the short rail for the guideway must have a rounded run-in (special version EG, see chapter 7.3) so that the overrunning cage causes as little pulsation as possible.

Not every cage is suitable for this application. The maximum cage overrun depends on the position of the rails and on the cage material.

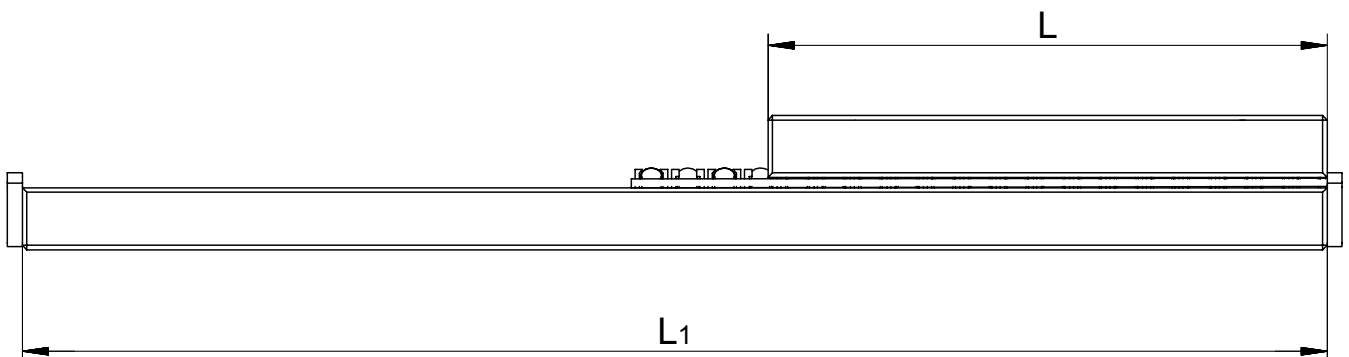

Maximum permitted installation ratios L to L1:

- for fixed guideways 1 : 2
- for laid on guideways 1 : 4

# 11 Design

## Installation variants for linear guideways with wipers

For different linear guideways wipers can be used in the form of end pieces ( $a_n$ ). Two installation variants are possible for this. In both instances this results in the following length ratios:

### Variant 1

Roller guideways with end pieces/wipers and rails **equal** in length:

$$K = L - H/2 - a_n$$

$$L_{tot} = L + H/2 + a_n$$

With this design the linear guideways must be fitted offset by the amount  $a_n$ .

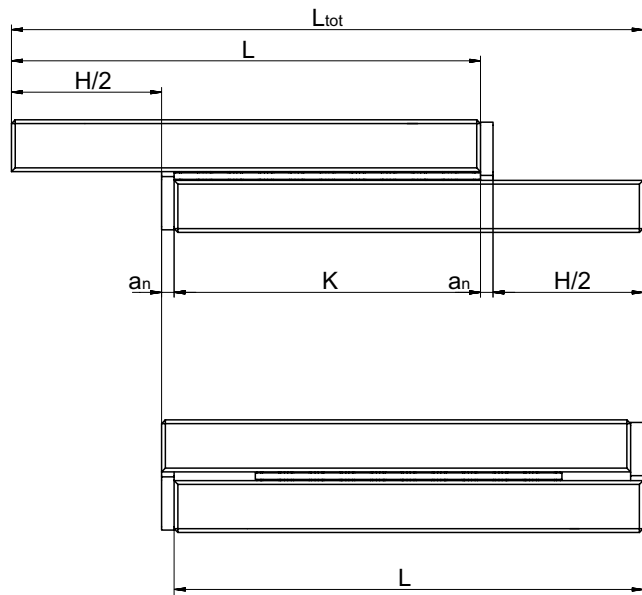

### Variant 2

Roller guideways with end pieces/wipers and rails **not equal** in length:

$$K = L - H/2$$

$$L_{tot} = L_1 + H \quad (\text{if the long guideway moves})$$

$$L_{tot} = L_1 \quad (\text{if the short guideway moves})$$

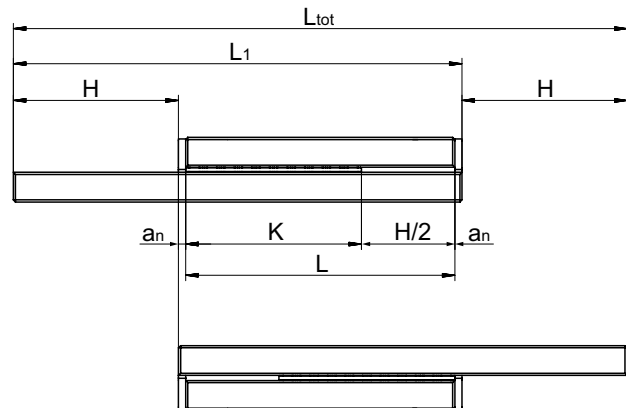

- K = Cage length in mm
- H = Stroke in mm
- L = Length in mm
- L<sub>1</sub> = Length in mm
- L<sub>to</sub> = Total length in mm
- a<sub>n</sub> = Thickness of the end piece in mm

## 11 Design

### 11.2 Recirculating units

When using recirculating units, theoretically there is not restriction in stroke. The stroke is only restricted by the length of the guide rails.

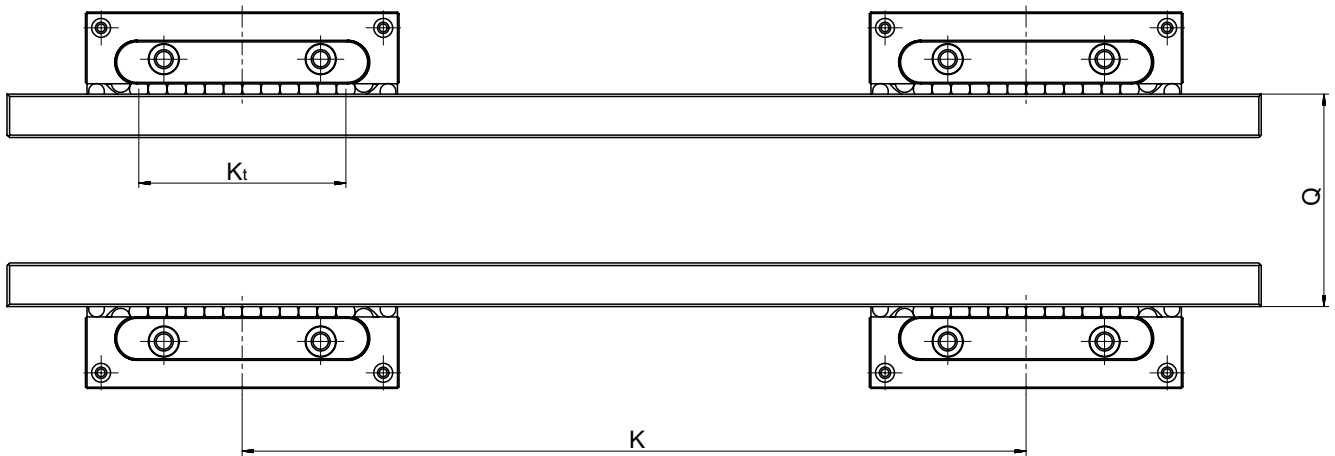

In terms of the spacing  $K$  between the recirculating units and the rail spacing  $Q$ , the following ratios are recommended as a guideline:

When using one recirculating unit per rail:  $\frac{K_t}{Q} \geq 1$

When using more than one recirculating unit per rail:  $\frac{K}{Q} \geq 1$

<p><math>K</math> = Spacing between the recirculating units in mm  <math>K_t</math> = Load-bearing length in mm  <math>Q</math> = Average rail spacing in mm</p>
--



## 12 Load carrying capacity and service life

### 12.1 Basic principles

The loading capacities are based on the principles specified by the ISO and DIN for calculation of roller-contact bearings (DIN ISO 14728).

In accordance with DIN in most applications a permanent overall deformation of 0.0001 times the rolling element diameter can be permitted without adversely affecting the operating behaviour of the bearing. Consequently, the static loading capacity  $C_0$  is set sufficiently high that the aforementioned deformation occurs approximately when the equivalent static load corresponds to the static loading capacity. So that the aforementioned overall deformation does not occur it is recommended being guided by the dynamic loading capacity  $C$ .

The dynamic loading capacity  $C$  is the load at which a nominal service life  $L$  of 100'000 m travel distance is achieved. It is important to note when calculating the service life that not only the load, which acts vertically on the guideway, should be taken into account but the load range of all acting forces and moments.

The service life corresponds to the travel distance in metres, which is travelled from a guideway. And this is before the first sign of material fatigue occurring to one of the roller guideway elements involved. The nominal service life is achieved when 90% of the guideways of identical construction reach or exceed the corresponding travel distances under normal operating conditions.

Critical for the dimensioning of the guideways are the loads occurring in the ratio with the dynamic loading capacity  $C$ .

#### Definition of service life

As previously mentioned, the dynamic loading capacity  $C_{100}$  is based on a service life of 100'000 m. Other manufacturers frequently indicate the loading capacity  $C_{50}$  for a service life of 50'000 m. The resulting load capacities from this are more than 20% higher than specified in the DIN ISO standard.

#### Conversion examples

##### For balls

Convert load capacities in accordance with DIN ISO standard to  $C_{50}$ :

$$C_{50} = 1.26 \cdot C_{100}$$

Convert  $C_{50}$  load capacities in accordance with DIN ISO standard to:

$$C_{100} = 0.79 \cdot C_{50}$$

##### For rollers and needles

Convert load capacities in accordance with DIN ISO standard to  $C_{50}$ :

$$C_{50} = 1.23 \cdot C_{100}$$

Convert  $C_{50}$  load capacities in accordance with DIN ISO standard to:

$$C_{100} = 0.81 \cdot C_{50}$$

$C_{50}$  = dynamic loading capacity  $C$  in N for 50'000 m of travel distance

$C_{100}$  = dynamic loading capacity  $C$  in N for 100'000 m of travel distance, defined in accordance with DIN ISO standard



## 12 Load carrying capacity and service life

### 12.2 Short strokes

We talk about short stroke applications when a rolling element does not travel past the position of the next rolling element during a stroke.

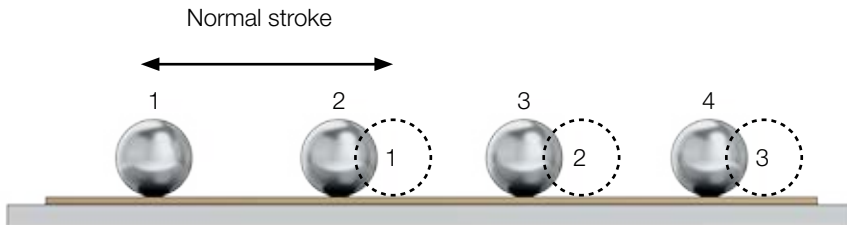

A continuous lubricating film forms below the rolling element

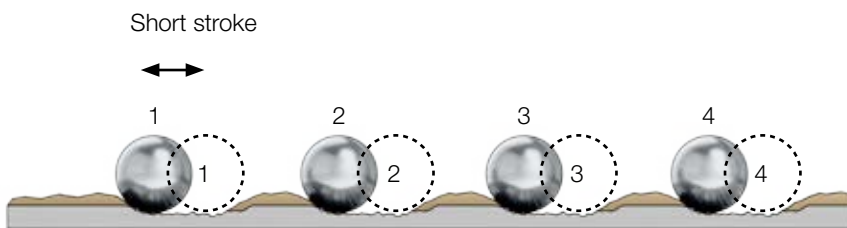

Local depressions from wear and tear form on the tracks.  
At highly frequent strokes the lubricating film is also interrupted

Because the tracks are concentrated at these points (depressions from wear and tear form), the precision and service life of the guideway is reduced. When the strokes are highly frequent, a standard lubricant is no longer able to reach the points of contact.

Wear and tear can be deferred with **suitable lubricants** and regular **lubrication strokes**.

Short strokes curtail the service life of the guideway considerably. The service life of the guideway(s) can only be determined by means of tests.

## 12 Load carrying capacity and service life

### 12.3 Calculating the service life L in accordance with the DIN ISO standard

The formulae for calculating service life are:

For rollers and needles:

$$L = a \cdot \left( \frac{C_{\text{eff}}}{P} \right)^{\frac{10}{3}} \cdot 10^5 \text{ m}$$

For balls:

$$L = a \cdot \left( \frac{C_{\text{eff}}}{P} \right)^3 \cdot 10^5 \text{ m}$$

a	= Event probability factor
$C_{\text{eff}}$	= Effective load carrying capacity per rolling element in N
P	= Dynamic, equivalent load in N
L	= Nominal service life in m

#### Event probability a

The load carrying capacities for roller-contact bearings correspond to the DIN ISO standard. This represents a value from the service life calculation, which is exceeded with a probability of 90% during operational use of the guideway.

If the previously mentioned theoretical service life probability factor of 90% is not adequate, the service life values will need to be adjusted by a factor a.

Event probability in %	90	95	96	97	98	99
Factor a	1	0.62	0.53	0.44	0.33	0.21

#### Effective load carrying capacity $C_{\text{eff}}$

External influences such as track hardness and temperature can reduce the loading capacity C which means that  $C_{\text{eff}}$  needs to be calculated.

$$C_{\text{eff}} = f_H \cdot f_T \cdot C$$

$C_{\text{eff}}$	= Effective load carrying capacity per rolling element in N
$f_H$	= Hardness factor
$f_T$	= Temperature factor
C	= Max. permissible load carrying capacity per rolling element in N

## 12 Load carrying capacity and service life

### Hardness factor $f_H$

Materials in a frictionless guideway, which deviate from the standard conditions (HRC 58 - 62), can be recorded with the factor  $f_H$ :

Track hardness in HRC	20	30	40	50	54	56	57	58-62
Hardness factor $f_H$	0.1	0.2	0.3	0.6	0.8	0.88	0.95	1

### Temperature factor $f_T$

Increased temperatures influence the operating conditions (material properties) and must be taken into account using the factor  $f_T$ .

Temperature of the guideway in °C	150	200	250	300
Temperature factor $f_T$	1	0.9	0.75	0.6

### Example calculation for $C_{eff}$

Guideway type R6 => Hardness 58 - 62 HRC =>  $f_H = 1$   
 Temperature 200°C =>  $f_T = 0.9$   
 Cage AA 6 =>  $C = 530$  N per roller

$$C_{eff} = f_H \cdot f_T \cdot C = 1 \cdot 0.9 \cdot 530 = \underline{477 \text{ N}}$$

## 12 Load carrying capacity and service life

### Dynamically equivalent load P

The loads (F) acting on a linear guideway system are subject to frequent fluctuations during operation. This set of circumstances should be taken into account when calculating service life. The varying load absorption of the guideway at varying operating conditions during the travel distance is described as being the dynamic equivalent load P.

#### Stepped load

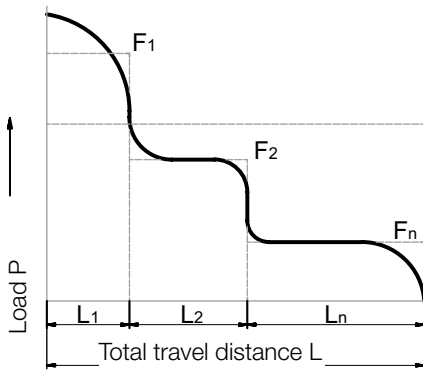

Formula for rollers and needles:

$$P = \sqrt[10]{\frac{1}{L} (F_1^{10} \cdot L_1 + F_2^{10} \cdot L_2 + \dots + F_n^{10} \cdot L_n)}$$

Formula for balls:

$$P = \sqrt[3]{\frac{1}{L} (F_1^3 \cdot L_1 + F_2^3 \cdot L_2 + \dots + F_n^3 \cdot L_n)}$$

#### Sinusoidal load

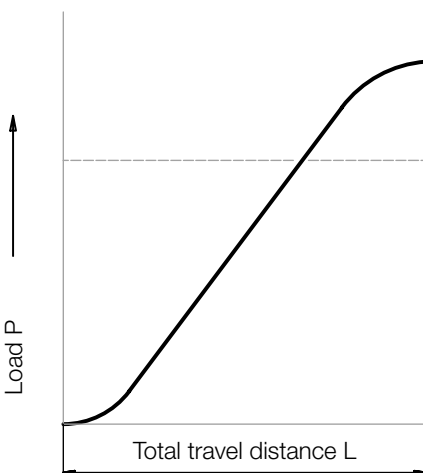

$$P = 0.7 F_{max}$$

P	= Equivalent load in N
F <sub>1</sub> ... F <sub>n</sub>	Individual load in N during the partial travel distance L ... L <sub>n</sub>
F <sub>max</sub>	Max. load in N
L	= L <sub>1</sub> + ... + L <sub>n</sub> = total travel during one load cycle in mm
L <sub>1</sub> ... L <sub>n</sub>	= partial travel distance in mm of one individual load during a load cycle

Example calculation with a linear guideway of type RNG 6-300 with KBN 6 cage

- an event probability of 97% is selected; the corresponds to a factor a of 0.44
- the dynamic loading capacity of a roller (for KBN 6 cage) is 1'800 N. If 16 rollers are used, the loading capacity of the guideway is 16 · 1'800 N = (28'800 N)
- the application generates a total load on to the guideway of 10'000 N

With the previously mentioned values, the following calculation for service life L is:

$$L = a \cdot \left( \frac{C_{eff}}{P} \right)^{\frac{10}{3}} \cdot 10^5$$

$$L = 0.44 \cdot \left( \frac{28'800 \text{ N}}{10'000 \text{ N}} \right)^{\frac{10}{3}} \cdot 10^5 = 1'495'412 \text{ m}$$

If the service life is requested in hours, the travelled stroke H (in meters) and the time t (in seconds) required for the stroke movement must be known.

The service life L<sub>h</sub> is calculated as follows:

$$L_h = \frac{L \cdot t}{H \cdot 3'600} = \text{Service life in hours}$$

## 12 Load carrying capacity and service life

### The correction factor $R_{Tmin}$

It was explained on the above pages how service life should be calculated from the given load carrying capacity and the occurring load. In so doing the number of load bearing rolling elements per cage ( $R_T$ ) should be taken into account.

Similarly important is estimating the behaviour of the surrounding structure when transmitting forces to the frictionless guideway. Then an elastic deformation or a geometric error in a machine bed lead to the fact that only a part of the installed rolling element effectively absorbs load.

Reliable statements on this application-specific issue can usually only be made with a great deal of difficulty, for example by taking measurements on functioning models or using calculations based on the method of finite elements. The result of this is that normally dimensioning takes place by taking simplified measures, i.e. the external load is divided up on to few rolling elements using the correction factor  $R_{Tmin}$ .

To determine  $R_{Tmin}$  first of all the connecting structure must be assessed based on the following values from historical experience:

- A = Rigid structure  
 $\delta_s \leq 0.1 \cdot \delta_A$
- B = Normal structure  
 $\delta_s > \delta_A$

$\delta_s$  = deformation of the connecting structure in  $\mu\text{m}$   
 $\delta_A$  = deformation of the rolling element including the guide rail in  $\mu\text{m}$   
 (see chapter 12.5)  
 $F$  = load in N  
 $X$  = distance in mm  
 $K_t$  = load-bearing cage length in mm

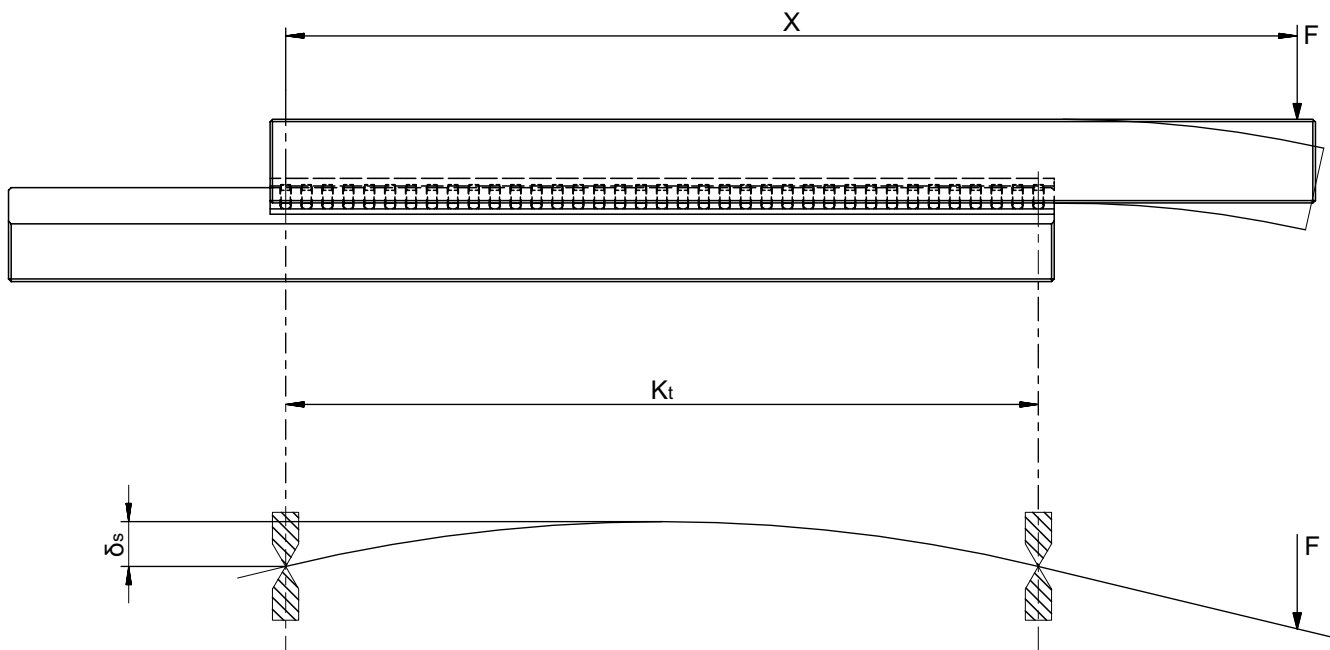

## 12 Load carrying capacity and service life

To calculate  $R_{Tmin}$  the following diagram applies

structure	A (rigid)	B (normal)
$X > K_t$	$R_{Tmin}$ to $R_T/4$	$R_{Tmin}$
$X < K_t$	as per diagram	as per diagram

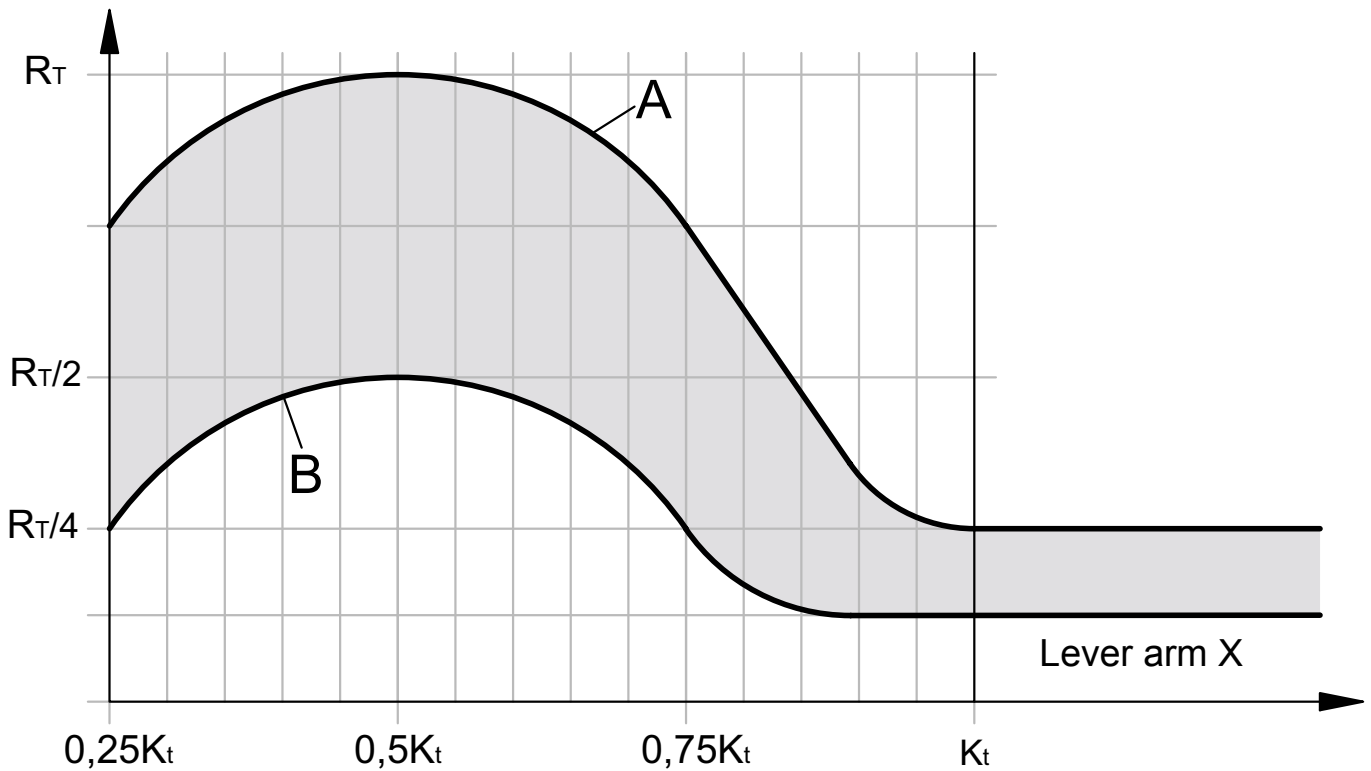

For $R_{Tmin}$ the following applies	Rolling element type	Cage types
2	Balls	AK
1	Rollers	AA, AC, EE, KBN and KBS
5	Needles	SHW and HW
0.5	Recirculating unit with rollers	SR and NRT
1	Recirculating unit with balls	SK, SKD and SKC

## 12 Load carrying capacity and service life

### Example calculation No. 1

AK 6 cage

X measures 200 mm

$K_t$  measures 90 mm

Consequently the method of calculation applies in accordance with " $X > K_t$ "

Calculation for a rigid structure:

- In accordance with the table, a ball count applies of  $R_{Tmin}$  to  $R_T/4$
- $R_{Tmin}$  corresponds to 2 balls
- $R_T/4$  corresponds to 2.25 balls

Calculation for a normal structure:

- In accordance with the table  $R_{Tmin}$   
 $R_{Tmin}$  corresponds to 2 balls

### Example calculation No. 2

AK 6 cage

X measures 80 mm

$K_t$  measures 90 mm

Consequently the method of calculation applies in accordance with " $X < K_t$ "

Calculation for a rigid structure:

- In accordance with the diagram, X 0.88 from  $K_t$  is corresponding (80 mm : 90 mm) and consequently  $R_T/2$   
For 9 load bearing balls, this results in 4.5 balls (9 load bearing balls : 2)

Calculation for a normal structure:

The following applies in accordance with diagram  $R_{Tmin}$ , which corresponds to 2 balls in accordance with the table

## 12 Load carrying capacity and service life

### 12.4 Example calculations

The following example calculations illustrate the procedure for some typical problems.

#### Example 1

Searched for:

Equivalent load P per roller

Assumption:

Linear guides type R 6

AC 6 cage with 8 rollers (=  $R_A$ )

$F = 350 \text{ N}$

$X = 120 \text{ mm}$

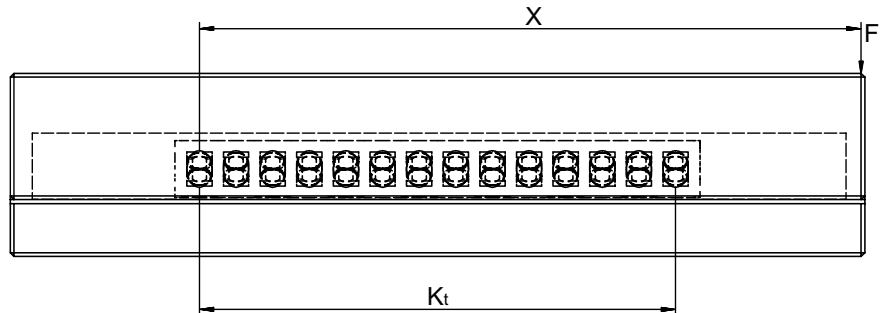

For the roller cage type AC 6 the following applies:

$$K_t = (R_A - 1) \cdot t = (8 - 1) \cdot 9 = 63$$

$R_{Tmin} = 1 \text{ roller}$

$C = 530 \text{ N}$

(see technical data for the AC 6 cage)

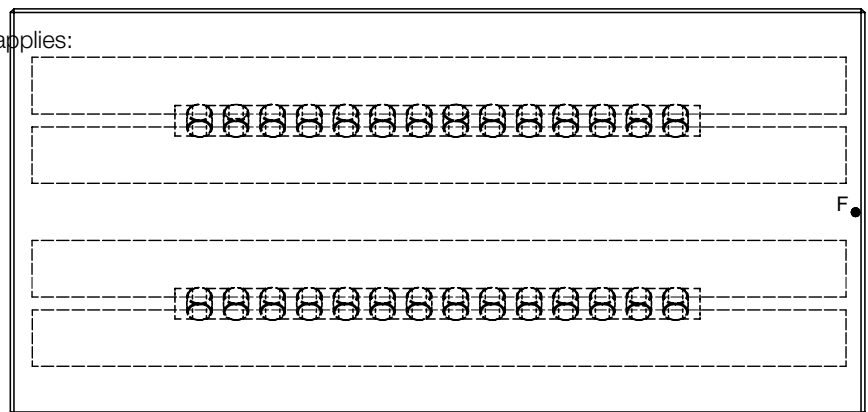

Note:

The asymmetric distribution of force is most safely taken into account when the load on the number of load bearing rolling elements ( $R_{Tmin}$ ) for the guideway is reduced.

Calculation for P per roller

$$P = \frac{F \cdot x}{K_t \cdot 2} \cdot \frac{1}{R_{Tmin}}$$

$$= \frac{350 \cdot 120}{63 \cdot 2} \cdot \frac{1}{1} = 334 \text{ N}$$

P is smaller than C. The design is correct in this way.

P	= Equivalent load in N per roller
F	= load in N
C	= Max. permissible load carrying capacity per rolling element in N
X	= distance in mm
$R_{Tmin}$	= Correction factor
$R_A$	= Total available rolling element per cage
t	= cage division in mm
$K_t$	= Load-bearing length in mm



## 12 Load carrying capacity and service life

### Example 2

Searched for:

Equivalent load P per roller

Assumption:

Linear guides type R 6

Roller cage type AC 6 cage with 20 rollers (=  $R_A$ )

$F = 6500 \text{ N}$

$C = 530 \text{ N}$  (according to techn. data for the AC 6 cage)

$$R_T = \frac{R_A}{2}$$

$$= \frac{20}{2} = 10 \text{ rollers}$$

Calculation for P per roller

$$P = \frac{F}{2} \cdot \frac{1}{R_T}$$

$$= \frac{6'500}{2} \cdot \frac{1}{10} = 325 \text{ N}$$

P is smaller than C. The design is correct in this way.

$w$  = Distance from cage start to the middle of the first rolling element in mm  
 $t$  = cage division in mm  
 $P$  = Equivalent load in N per roller  
 $F$  = load in N  
 $C$  = Max. permissible load carrying capacity per rolling element in N  
 $R_T$  = Number of load-bearing rolling elements per cage

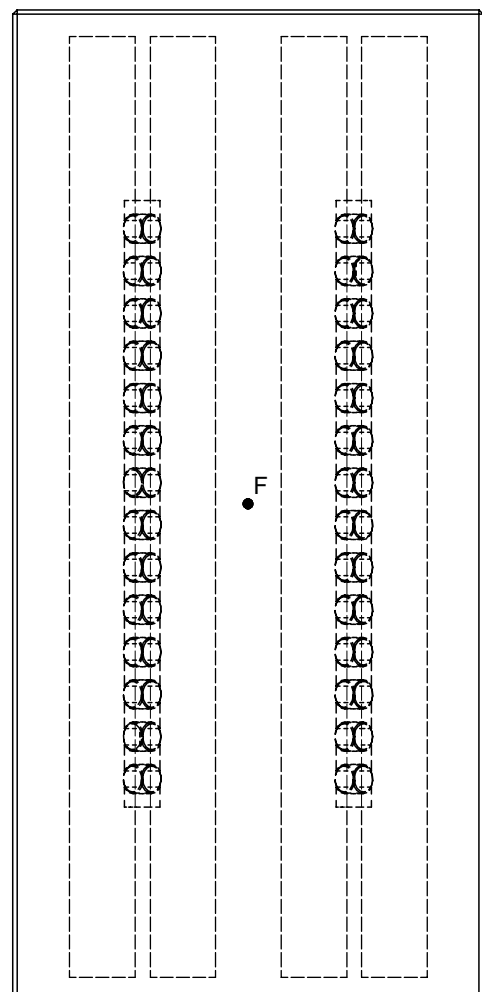
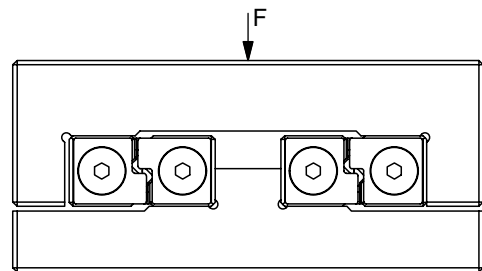

## 12 Load carrying capacity and service life

### Example 3

Searched for:

Equivalent load P per ball

Assumption:

Rigid slide structure

Linear guides type R 6

Cage type AK 6 with 12 balls (=  $R_A$ );  $t = 9$  mm  
(according to techn. data for the AK 6 cage)

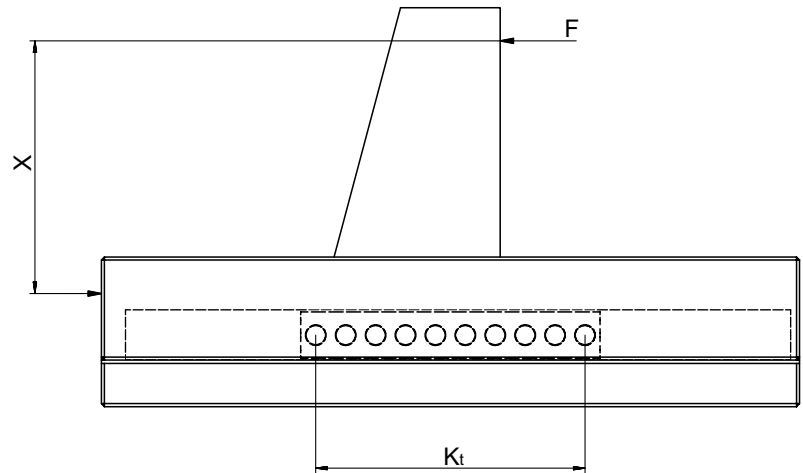

$$R_A = R_T = 12 \text{ balls}$$

$$R_{Tmin} = 3 = R_T/4 \text{ according to diagram on page 101}$$

$$K_t = (R_A - 1) \cdot t$$

$$F = 240 \text{ N}$$

$$X = 75 \text{ mm (distance F to opposing force)}$$

$$C = 65 \text{ N (according to chapter 5.1, technical data for the AK 6 cage)}$$

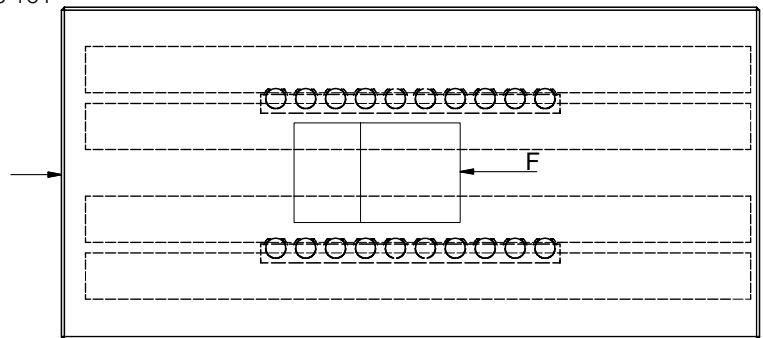

Calculation for P per ball:

$$P = \frac{F}{K_t} \cdot \frac{X}{2} \cdot \frac{1}{R_{Tmin}}$$

$$= \frac{240}{99} \cdot \frac{75}{2} \cdot \frac{1}{3} = 30 \text{ N}$$

P is smaller than C. The design is correct in this way.

t	= cage division in mm
P	= Equivalent load in N per ball
F	= load in N
C	= Max. permissible load carrying capacity per rolling element in N
$R_{Tmin}$	= Correction factor
$R_A$	= Total available rolling element per cage
$R_T$	= Number of load-bearing rolling elements per cage
$K_t$	= Load-bearing length in mm

## 12 Load carrying capacity and service life

### Example 4

Searched for:

Equivalent load P per roller and the suitable size RNG guideways

Assumption:

Type RNG linear guideways

Roller cage type KBN with 10 rollers ( $R_A$ )

$F = 15'000 \text{ N}$

$X = 50 \text{ mm}$

$Q = 100 \text{ mm}$

$$R_T = \frac{R_A}{2}$$

$$= \frac{10}{2} = 5 \text{ rollers}$$

Calculation for P per roller

$$P_1 = \frac{F \cdot X}{Q} \cdot \frac{1}{R_T}$$

$$= \frac{15'000}{10} \cdot \frac{1}{10} = 1'500 \text{ N}$$

$$P_2 = \frac{F}{R_A} \cdot \frac{1}{R_T}$$

$$= \frac{15'000}{10} = 1'500 \text{ N}$$

$$P = P_1 + P_2$$

$$= 1'500 + 1'500 = 3'000 \text{ N}$$

P ( $P_1, P_2$ ) = Equivalent loads in N per roller  
 F = load in N  
 X = distance in mm  
 Q = Medium linear guideway distance in mm  
 C = Max. permissible load carrying capacity per rolling element in N  
 $R_T$  = Number of load-bearing rolling elements per cage  
 $R_A$  = Total available rolling element per cage

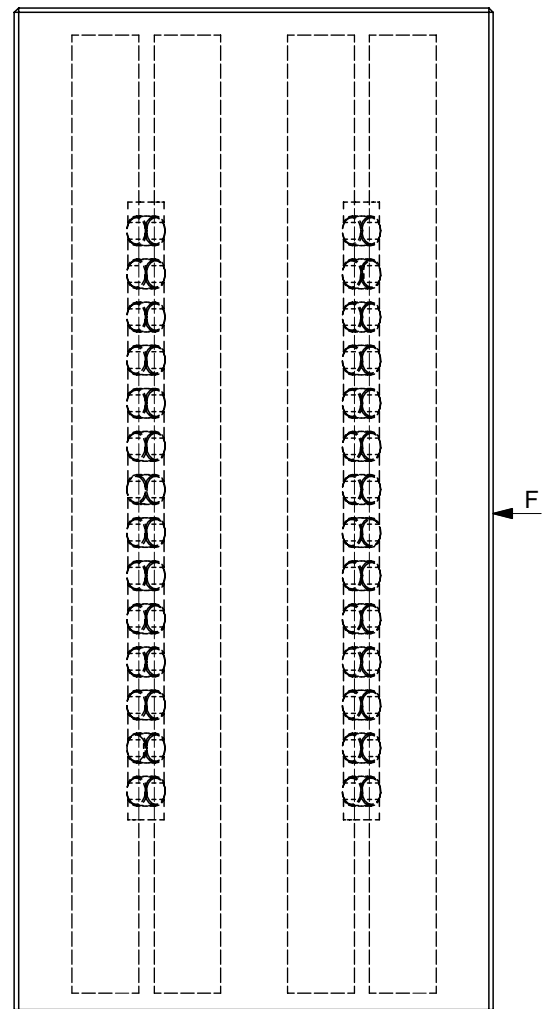
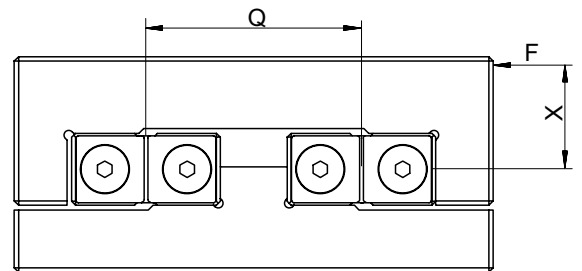

Definition of the suitable guideway size:

According to product specification for the KBN cage (chapter 5.2 or 5.3) if  $C = 3'900 \text{ N}$  were to be selected

Model	Size	Dw	t	w	C per roller in N
KBN	4	4.5	6.5	approx. 4	850
	6	6.5	8.5	approx. 5	1'800
	9	9	12	approx. 7.5	3'900
	12	12	15	approx. 9	6'500

The ball size 9 is suitable. Thus select cage KBN 9 and the linear guideway RNG 9, provided the service life has been fulfilled.

## 12 Load carrying capacity and service life

### Example 5

Searched for:

Equivalent load P per needle

Assumption:

Linear guideways type N/O 2025

SHW 15 cage, cage length K = 194 mm

(w = 2.9 mm according to techn. specifications of the SHW 15 cage)

F = 5'000 N

X = 280 mm

Q = 75 mm

C = 750 N (according to techn. specifications for the AC 15 cage)

$$R_A = R_T = \frac{K - 2w}{t} + 1$$

$$= \frac{194 - 5.8}{2.9} + 1 = 48 \text{ needles}$$

Calculation for P per needle:

$$P = \frac{F \cdot X}{Q} \cdot \frac{1}{R_T}$$

$$= \frac{5'000 \cdot 280}{75} \cdot \frac{1}{48} = 389 \text{ N}$$

P is smaller than C. The design is correct in this way.

w = Distance from cage start to the middle of the first rolling element in mm  
 t = cage division in mm  
 P = Equivalent load in N per needle  
 F = load in N  
 X = distance in mm  
 Q = Medium linear guideway distance in mm  
 C = Max. permissible load carrying capacity per rolling element in N  
 R<sub>T</sub> = Number of load-bearing rolling elements per cage  
 R<sub>A</sub> = Total available rolling element per cage  
 K = Cage length in mm

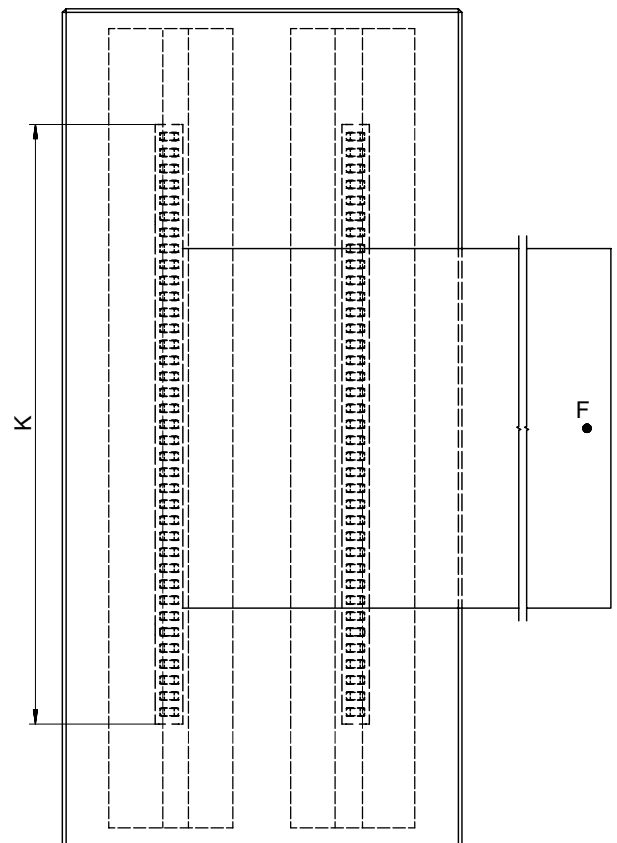
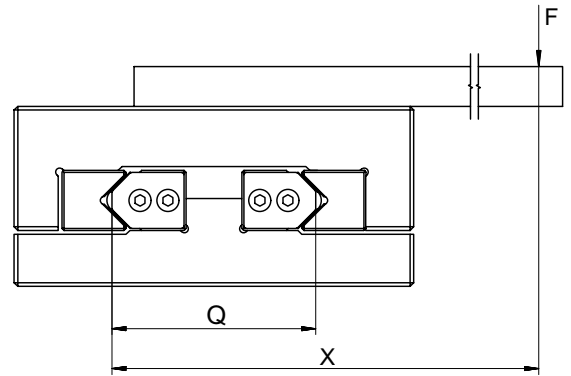

## 12 Load carrying capacity and service life

### Example 6

Searched for:

Equivalent load P per roller

Assumption:

Rigid structure

Linear guides type R 12

Cage type AC 12, length K = 400 mm

F = 2'000 N

X = 500 mm

X<sub>1</sub> = 200 mm

Q = 100 mm

C = 2'500 N (see chapter 5.1,  
technical specifications for the AC 12 cage)

For the roller cage AC 12 the following applies:

$$K_t = K - 2w$$

$$= 400 - 22 = 378 \text{ mm}$$

$$R_A = \frac{K_t}{t} + 1$$

$$= \frac{378}{18} + 1 = 22 \text{ rollers}$$

$$R_T = \frac{R_A}{2}$$

$$= \frac{22}{2} = 11 \text{ rollers}$$

X > K<sub>t</sub> = R<sub>T</sub>/4 (according to the diagram on page 101)

$$R_{TQ} = R_T$$

$$R_{TL} = \frac{R_T}{4} = \frac{11}{4} = 2.75 \text{ rollers (rounded down to 2)}$$

Calculation for P per roller

Load laterally

$$P_Q = \frac{F \cdot X_1}{Q} \cdot \frac{1}{R_{TQ}}$$

$$= \frac{2'000 \cdot 200}{100} \cdot \frac{1}{11} = 364 \text{ N}$$

Load longitudinally

$$P_L = \frac{F \cdot X}{K_t \cdot 2} \cdot \frac{1}{R_{TL}}$$

$$= \frac{2'000 \cdot 500}{378 \cdot 2} \cdot \frac{1}{2} = 662 \text{ N}$$

$$P = P_Q + P_L$$

$$= 364 + 662 = 1'026 \text{ N}$$

P is smaller than C. The design is correct in this way.

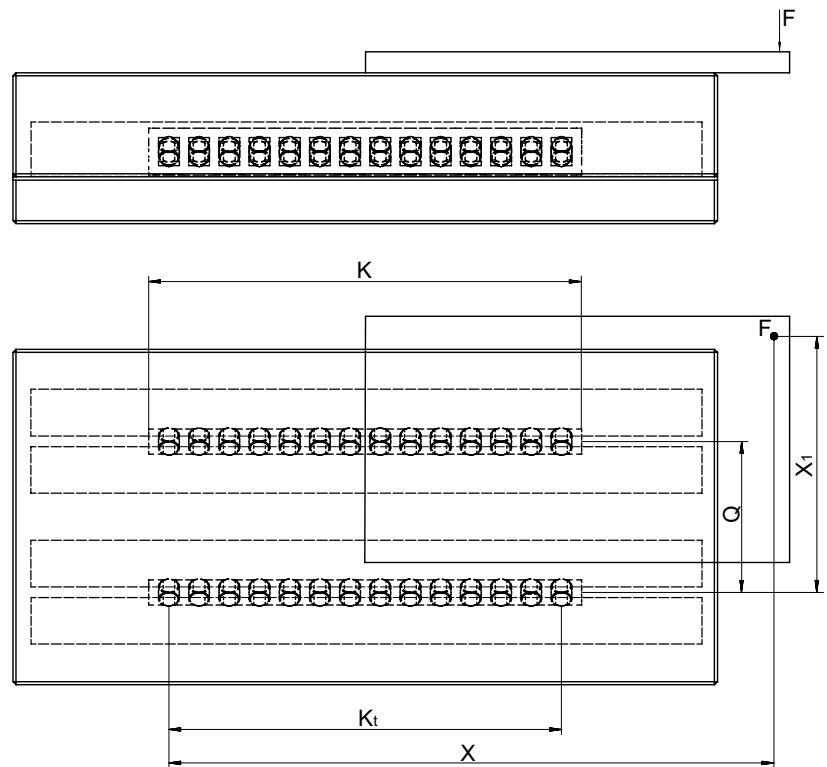

w	= Distance from cage start to the middle of the first rolling element in mm
t	= cage division in mm
P	= Equivalent load in N per roller
F	= load in N
X	= distance in mm
X <sub>1</sub>	= distance in mm
Q	= Medium linear guideway distance in mm
C	= Max. permissible load carrying capacity per rolling element in N
R <sub>T</sub>	= Number of load-bearing rolling elements per cage
R <sub>A</sub>	= Total available rolling element per cage
K	= Cage length in mm
K <sub>t</sub>	= Load-bearing length in mm
...L	= Longitudinally
...Q	= Laterally

## 12 Load carrying capacity and service life

### Example 7

Searched for:

Equivalent load P

Assumption:

Recirculating unit type SR 6-100

Linear guides type R 6

$R_T$  = 2 recirculating unit

$F$  = 6'000 N

$C$  = 2'150 N (see chapter 6.3,  
technical specifications for the recirculating unit)

Calculation for P:

$$P = \frac{F}{2} \cdot \frac{1}{R_T}$$

$$= \frac{6'000}{2} \cdot \frac{1}{2} = 1'500 \text{ N}$$

P is smaller than C. The design is correct in this way.

$P$  = Equivalent loads in N  
 $F$  = load in N  
 $C$  = Max. permissible load carrying capacity in N  
 $R_T$  = Number of load-bearing recirculating units

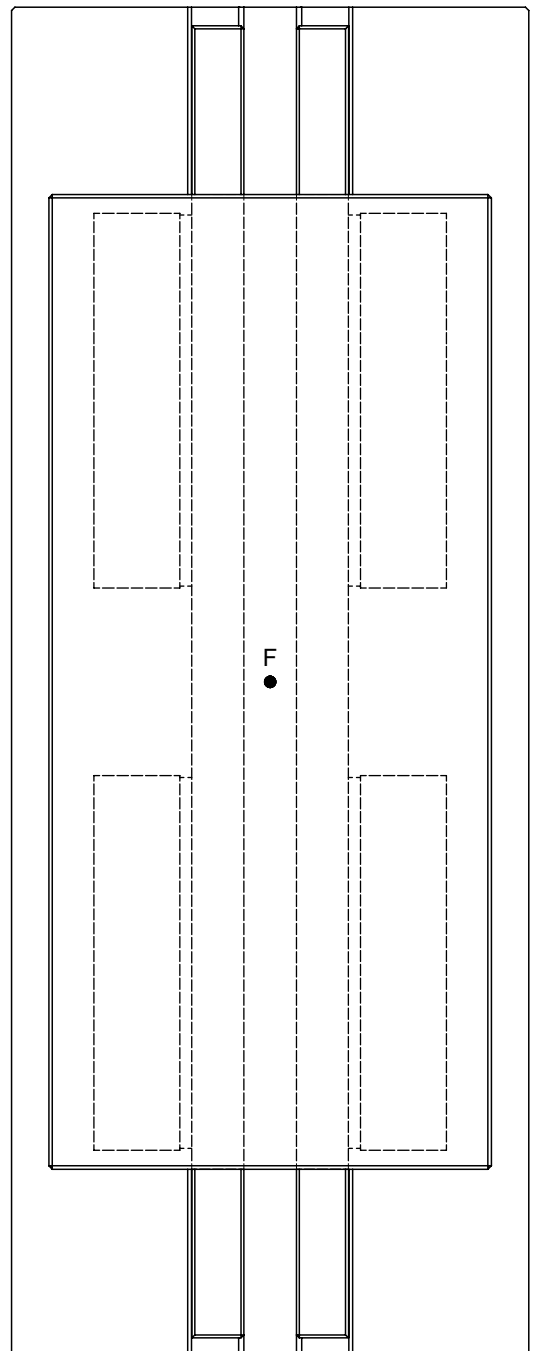
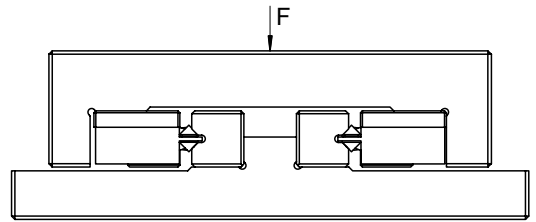

## 12 Load carrying capacity and service life

### Example 8

Searched for:

Moment load  $M$  in Nm longitudinally and laterally

Assumption:

Recirculating unit type SR 6-150

Linear guideways type RD 6

$M_L = 112$  Nm (according to chapter 6.3, technical specifications  
for the recirculating unit)

$X = 45$  mm (distance  $F$  to opposing force)

$F = 2'000$  N

Calculation for  $M$ :

$$M = F \cdot X = 2000 \cdot 0,045 = 90 \text{ Nm}$$

The moment load  $M$  is below the permissible load  $M_L$ . Thus the design is correct.

$M$  = Moment load in Nm longitudinally and laterally  
 $M_L$  = Permitted moment load in Nm longitudinally and laterally  
 $X$  = distance in mm  
 $F$  = load in N

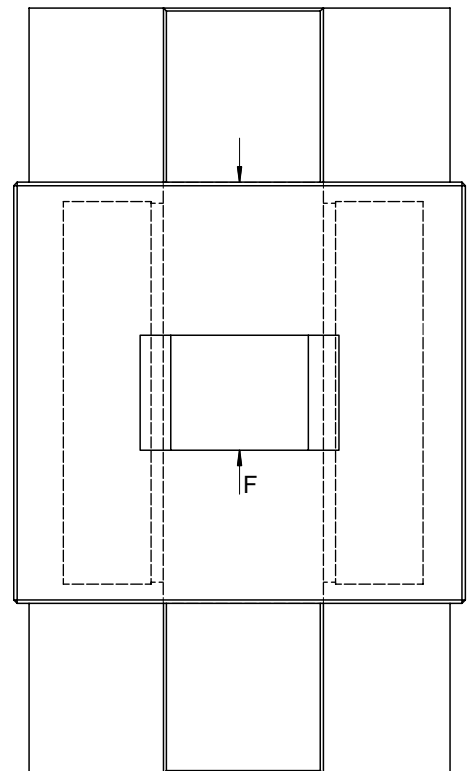
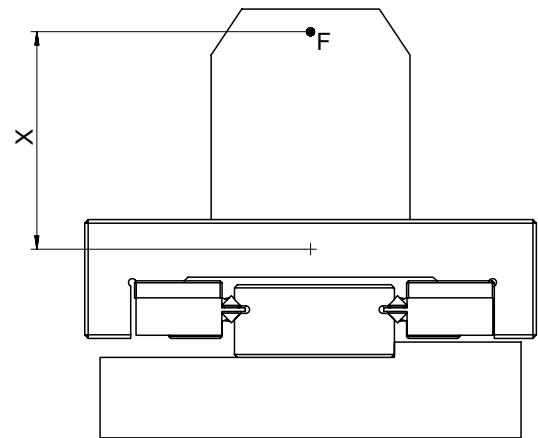

## 12 Load carrying capacity and service life

### Example 9

Searched for:

Equivalent loads  $P_L$  and  $P_Q$

Assumption:

Recirculating unit top type NRT 26 111 ( $C = 98'000$  N)  
 Recirculating unit bottom type NRT 19 077 ( $C = 43'000$  N)  
 Recirculating unit side type NRT 19 077 ( $C = 43'000$  N)  
 $K = 700$  mm  
 $K_t = 450$  mm  
 $R_{Tmin} = 0.5$  (according to table on page 101)  
 $F = 83'000$  N  
 $X = 500$  mm  
 $Y = 100$  mm

Calculation for  $P_L$  and  $P_Q$ :

Load longitudinally

$$P_L = \frac{F \cdot X}{K \cdot 2} \cdot \frac{1}{R_{Tmin}}$$

$$= \frac{83'000 \cdot 500}{700 \cdot 2} \cdot \frac{1}{0.5} = 59'286 \text{ N}$$

Load laterally

$$P_Q = \frac{F \cdot Y}{K_t \cdot 2} \cdot \frac{1}{R_{Tmin}}$$

$$= \frac{83'000 \cdot 100}{450 \cdot 2} \cdot \frac{1}{0.5} = 36'889 \text{ N}$$

$P$	= Equivalent load in N
$P_L$	= Equivalent load longitudinally in N
$P_Q$	= Equivalent load laterally in N
$F$	= load in N
$X$	= distance in mm
$Y$	= distance in mm
$C$	= Max. permissible load carrying capacity per recirculating unit in N
$R_{Tmin}$	= Correction factor
$K$	= distance in mm
$K_t$	= Load-bearing length in mm

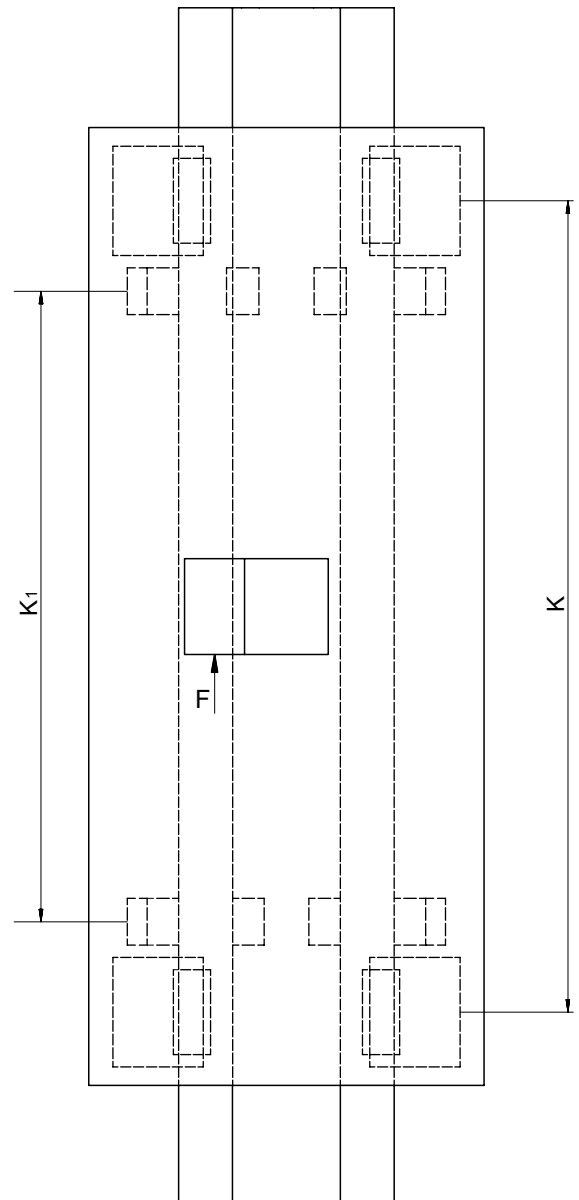
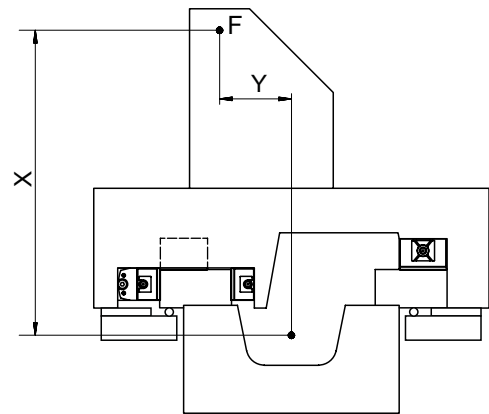



## 12 Load carrying capacity and service life

### 12.5 Elastic deformation and rigidity

#### Linear guideways

The total deformation  $\delta_A$  (that is the deformation of the rolling element in connection with hardened tracks (min. 58 HRC) ) can be deduced from the following diagrams.

The elastic deformation of the linear guideways of type R

In relation to the load P per roller

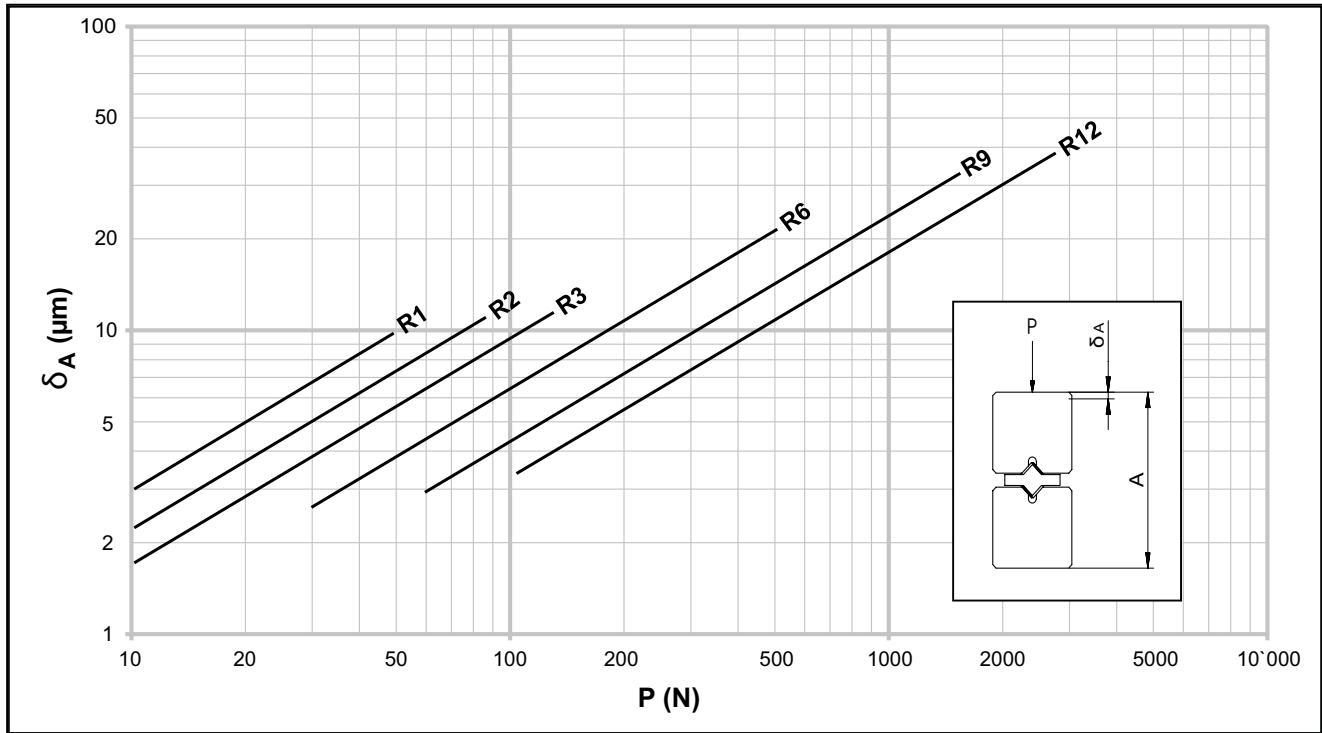

In relation to the load P per ball

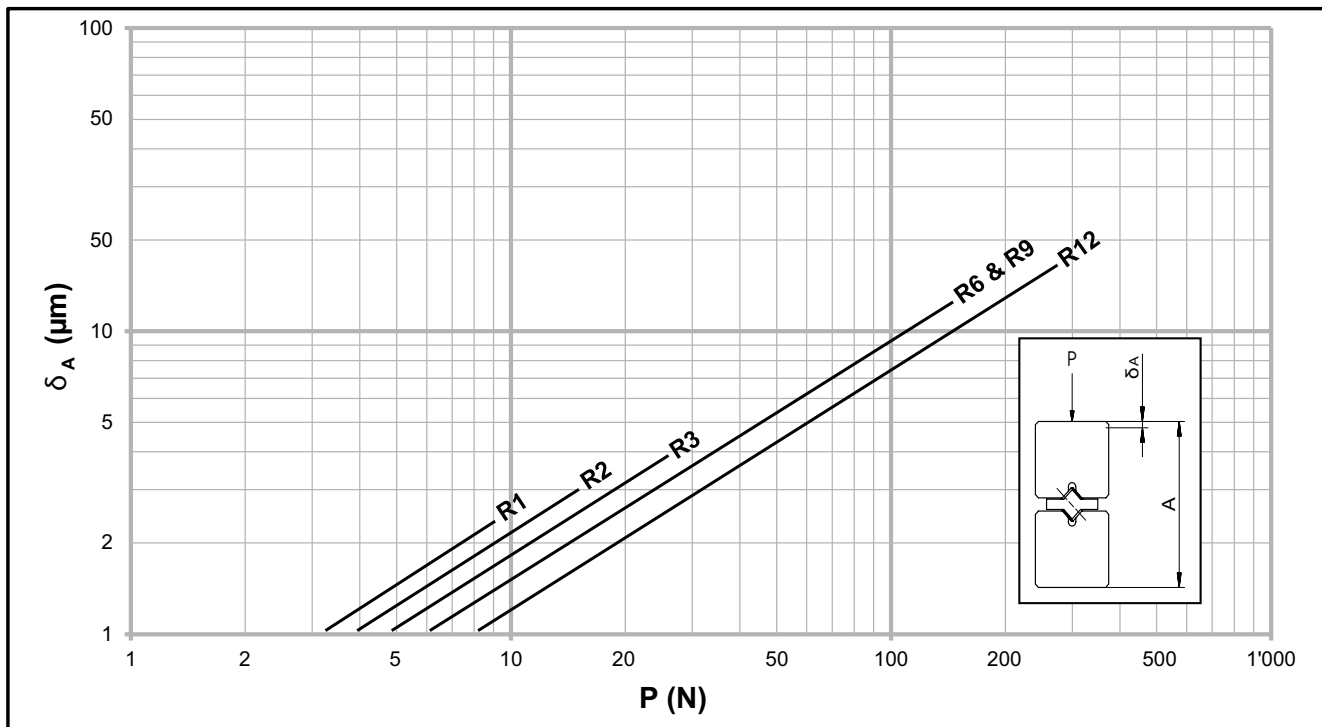

## 12 Load carrying capacity and service life

The elastic deformation of the linear guideways for type RN and RNG relate to the load P per roller

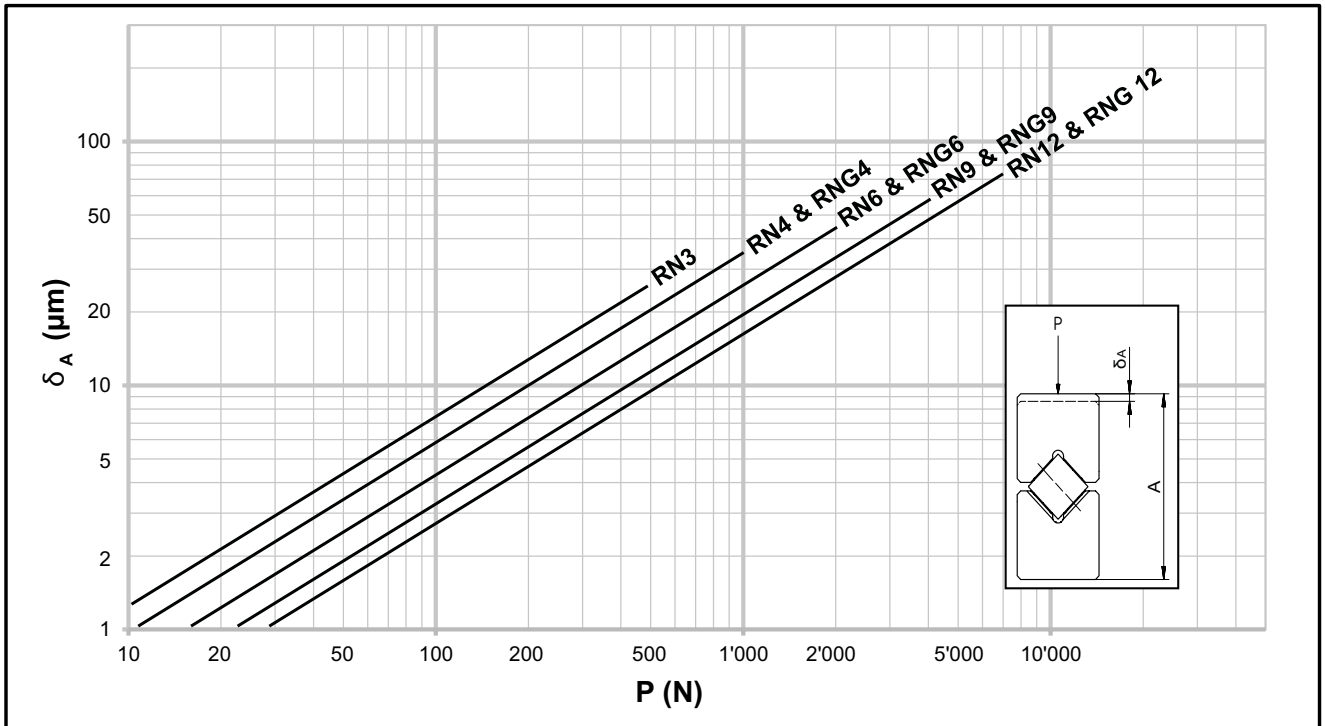

The elastic deformation of the linear guideways for type N/O and M/V relate to the load P per pair of needles

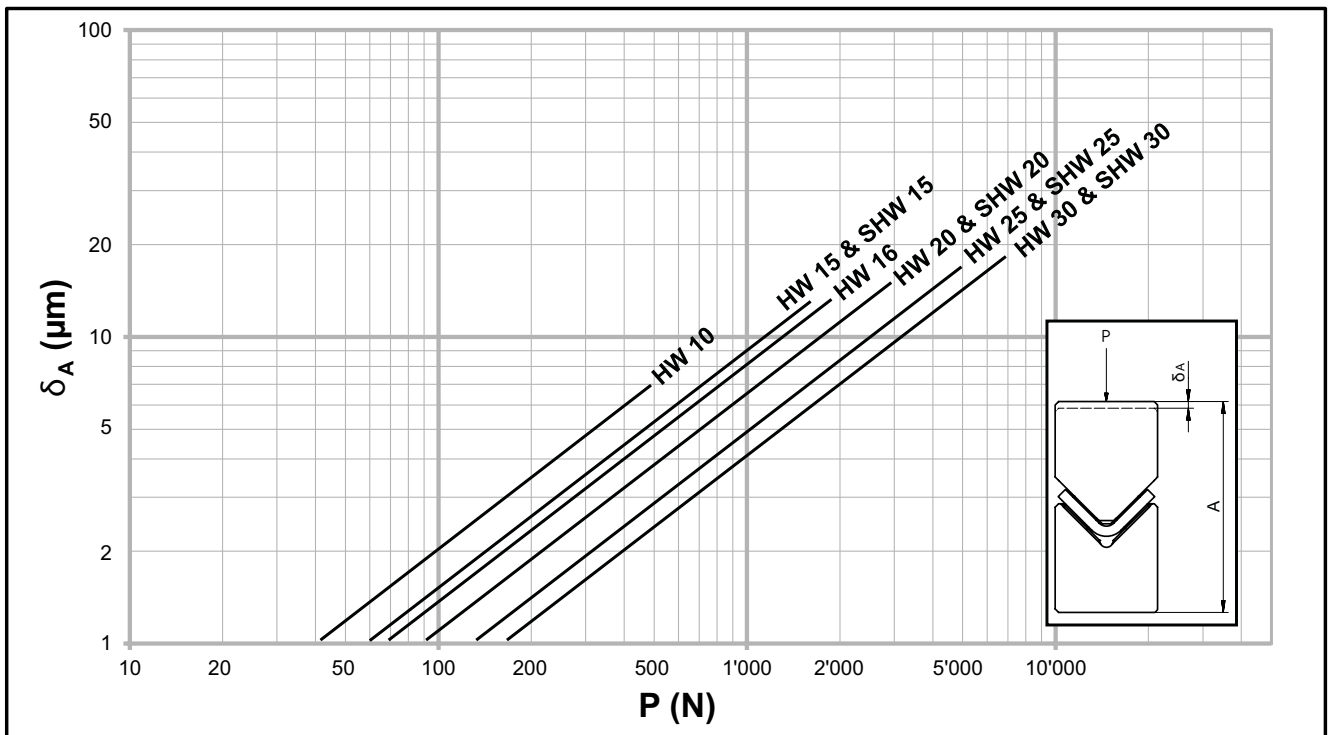

## 12 Load carrying capacity and service life

### Recirculating units

The elastic deformation of the recirculating unit of type SK in connection with linear guideways type R or RD

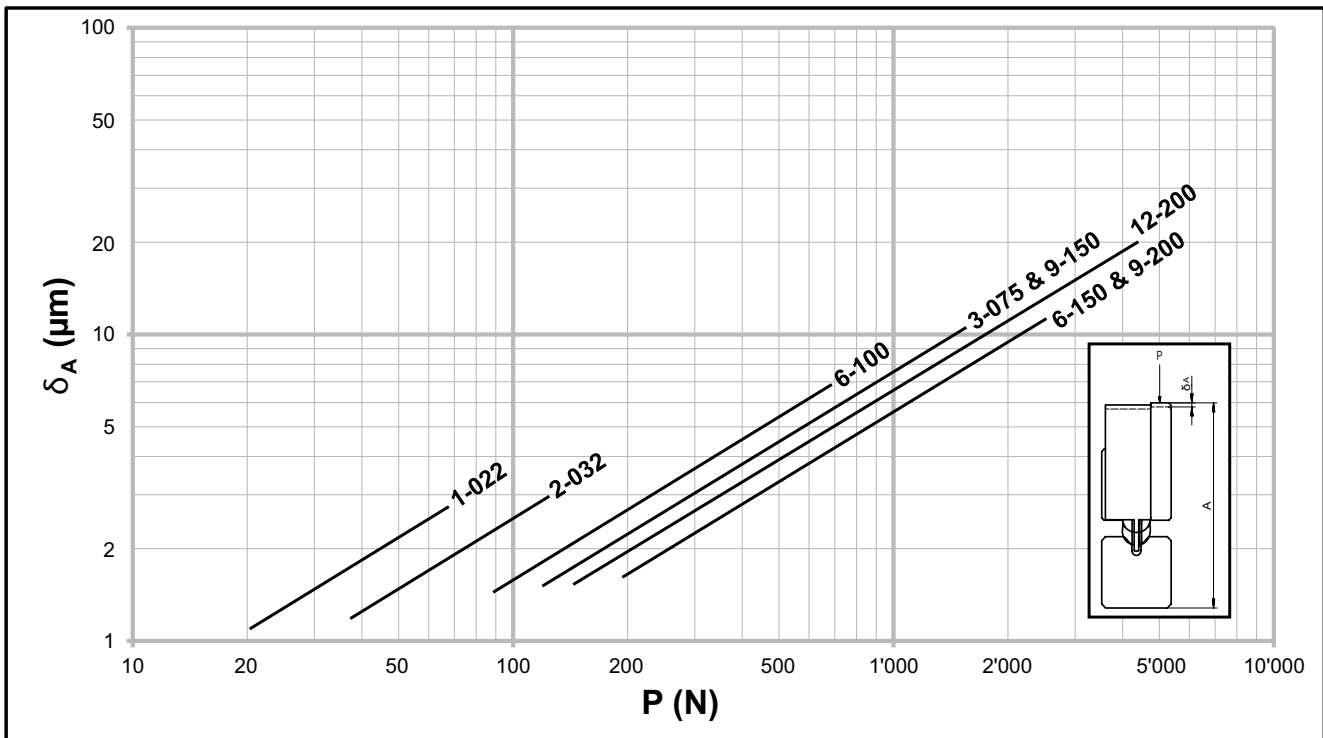

The elastic deformation of the recirculating unit of type SKD in connection with linear guideways type R or RD

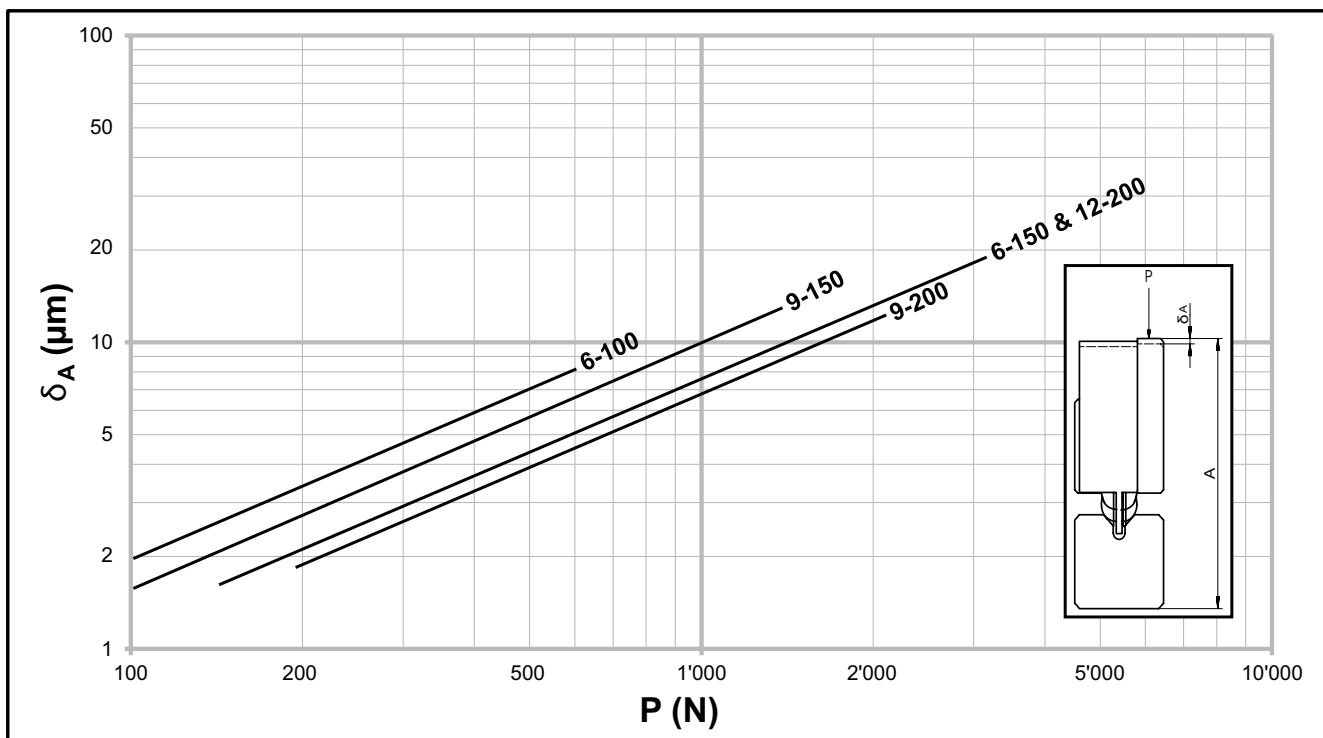

## 12 Load carrying capacity and service life

The elastic deformation of the recirculating unit of type SKC in connection with linear guideways type R or RD. The total length of the straight lines applies for lubricated recirculating units, the dotted straight line for unlubricated ones.

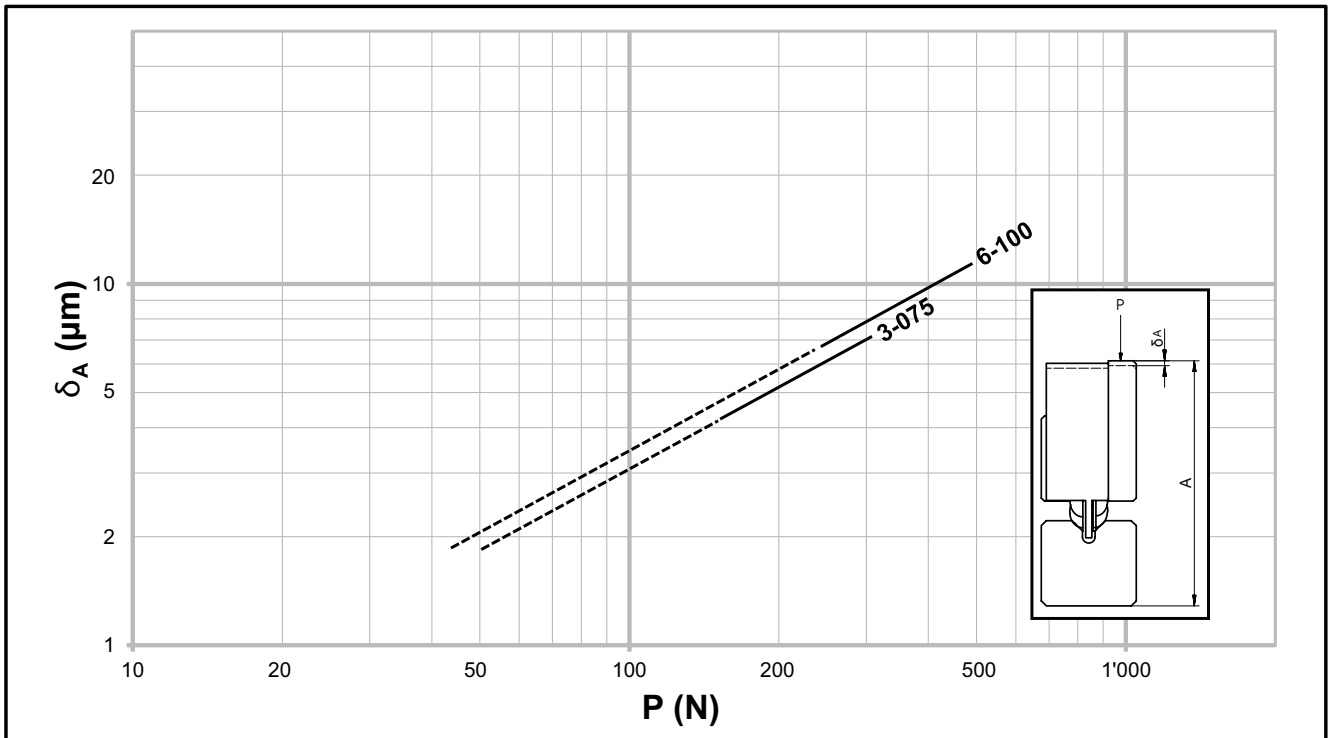

The elastic deformation of the recirculating unit of type SR in connection with linear guideways type R or RD.

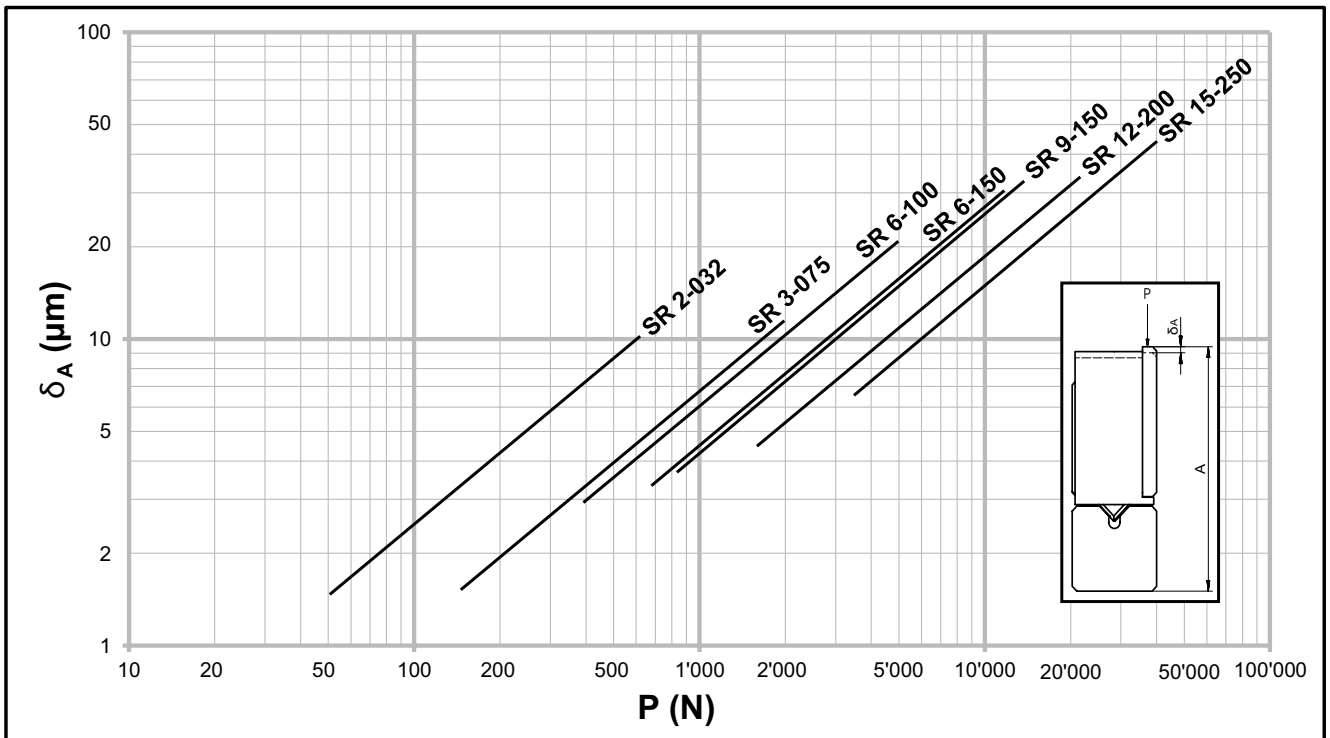

## 12 Load carrying capacity and service life

The elastic deformation of the recirculating unit type NRT in connection with hardened tracks

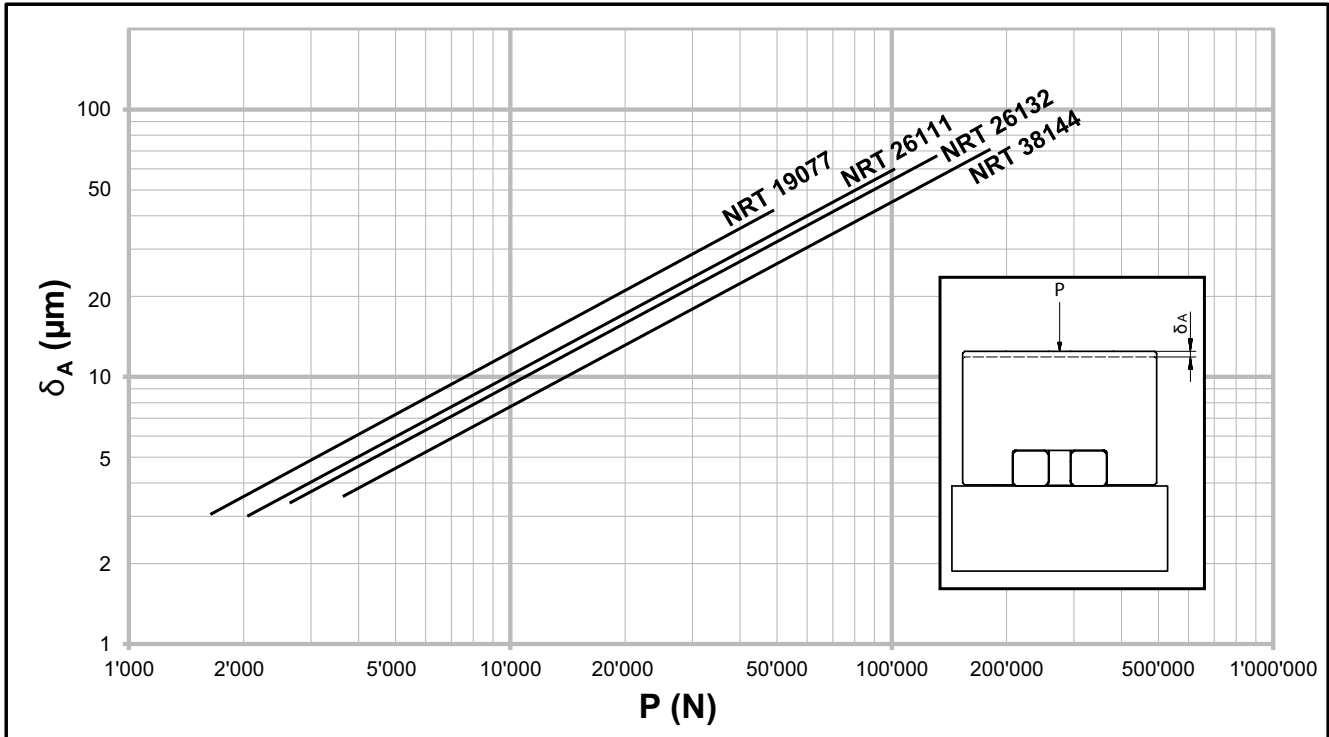

## 13 Construction and installation guidelines

### 13.1 The connecting structure and its influence on service life

Linear guideways are high-precision components. The requirements in respect of the connecting structure are correspondingly high so that inaccuracies are not transferred to the guideways.

The quality of the reference and supporting surfaces as well as the rigidity of the connecting structure must meet the most stringent requirements. If this is not the case, smoothness, precision and service life of the guideway will be significantly affected.

To exploit the full potential of the linear guideways, assembly on a rigid and ground substrate is recommended. Connecting structures made of light metal are only suitable in certain instances - due to their lower rigidity and limited machining accuracy.

### 13.2 Configuration of the connecting structure

#### Parallelism of the reference and locating surfaces

They must be compatible with those of the linear guideway (also applies when using linear guideways with recirculating units):

- NQ Normal quality
- SQ Special quality
- SSQ Super special quality

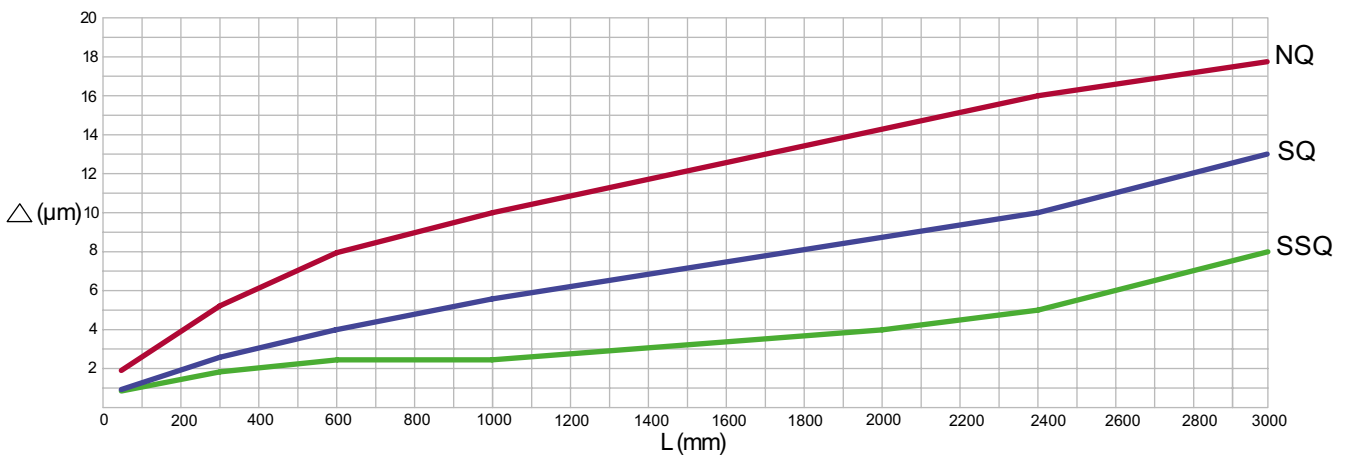

#### Surface quality

The accuracy of the application critically determines the required surface quality of the reference and locating surfaces. For high-precision applications they must demonstrate a maximum Ra value of 0.4. An Ra value of 1.6 may not be exceeded for standard applications.

# 13 Construction and installation guidelines

## Angular error

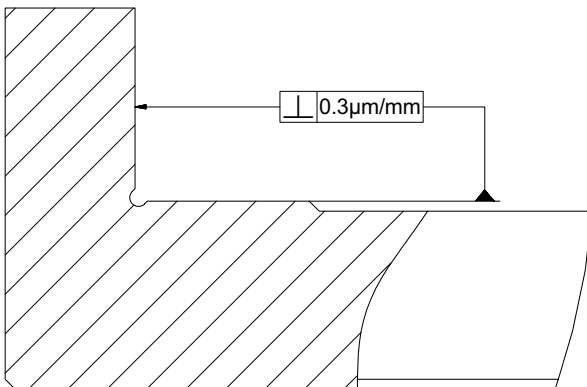

The angular errors for the supporting and locating surface should not exceed  $0.3 \mu\text{m}/\text{mm}$ .

## Height offset for linear guideways

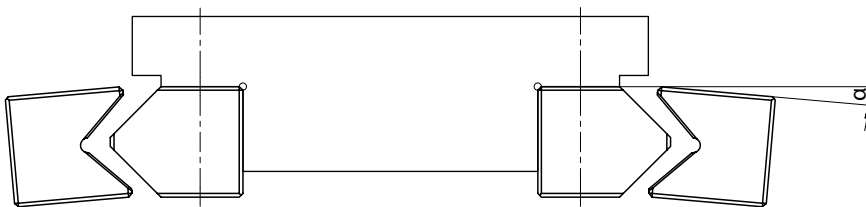

The angular errors resulting from height offset and/or elastic deformations may not exceed the following values:

- Balls or rollers:  $0.3 \mu\text{m}/\text{mm}$
- Needles:  $0.1 \mu\text{m}/\text{mm}$

## Parallelism of the supporting and locating surfaces in the case of the recirculating unit

The parallelism of the supporting and locating surfaces in relation to the mating track can be derived from the diagram below:

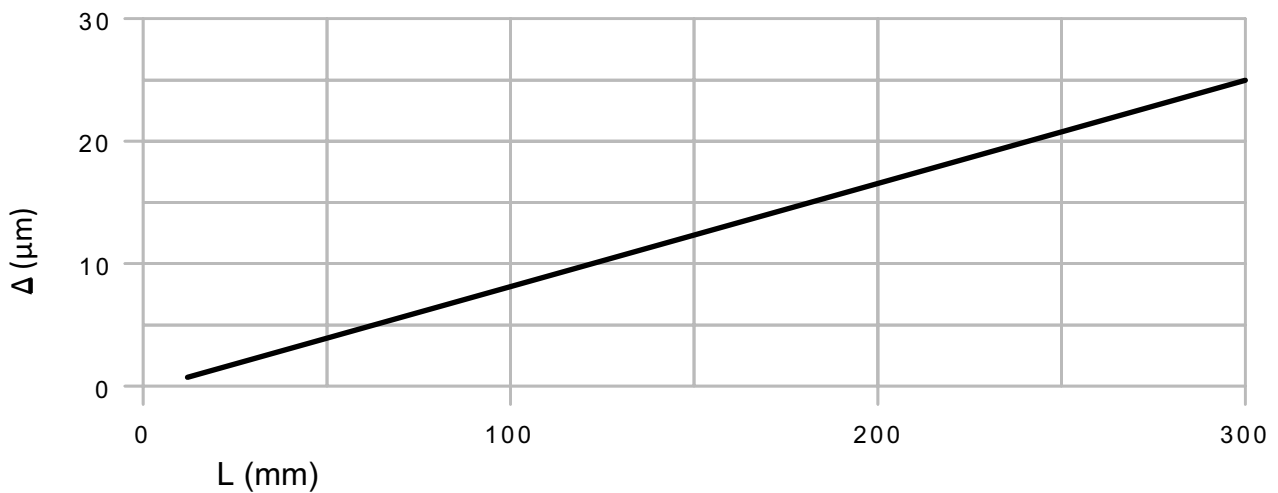

# 13 Construction and installation guidelines

## Height offset for recirculating units

The angular errors results from height offset and/or elastic deformations may not exceed the following values:

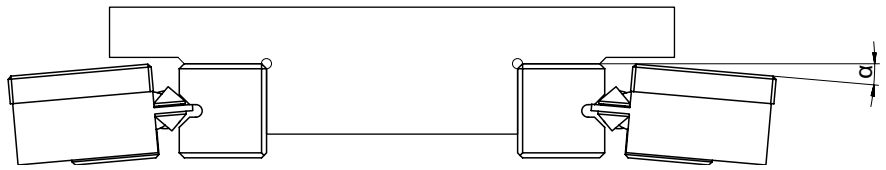

For types SK, SKD and SKC      3.0  $\mu\text{m}/\text{mm}$   
 For types SR                      0.3  $\mu\text{m}/\text{mm}$

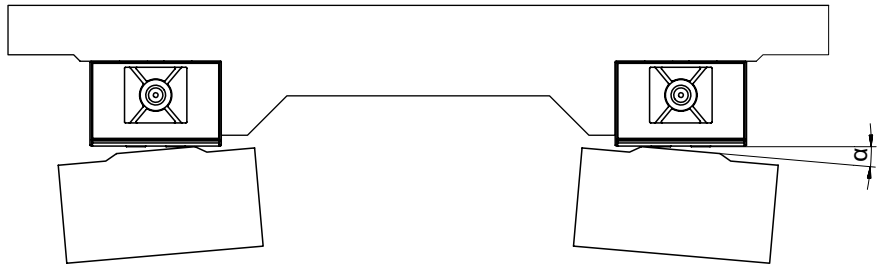

For types NRT                      0.3  $\mu\text{m}/\text{mm}$

## Combination of recirculating unit NRT with preload wedge NRV

So that straight run-off is guaranteed, the recirculating unit NRT must always be oriented against the locating surface. The preload wedge NRV should be adjusted opposite the recirculating unit.

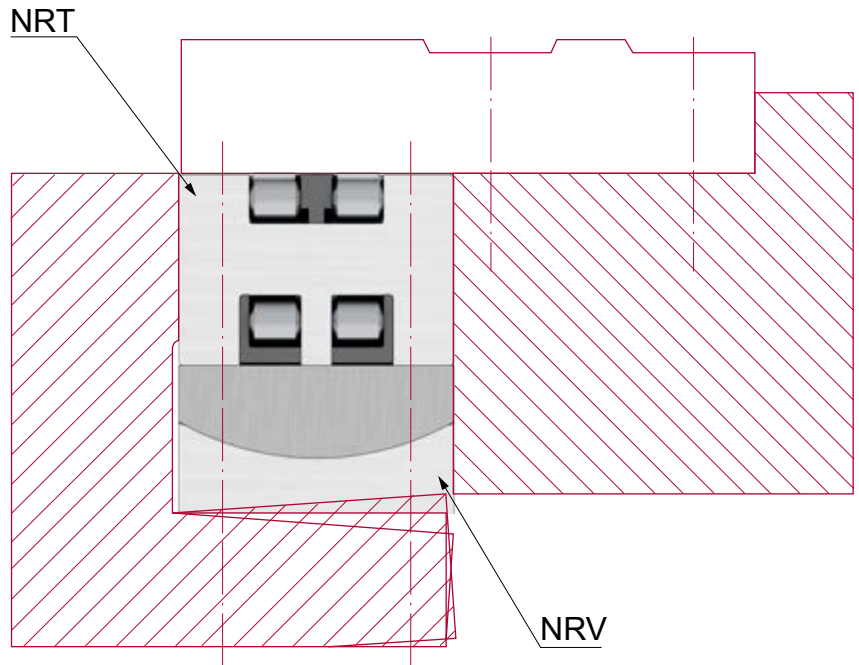



## 13 Construction and installation guidelines

### 13.3 Installation methods

SCHNEEBERGER linear guideways are not designed to be load-bearing structural components, but as guideway components.

All applications are designated as horizontal installation, whose direction of movement runs horizontally. All applications are designated as vertical installation, whose direction of movement deviates from the horizontal plane.

#### Enclosed configuration

The enclosed configuration is a fixed/fixed bearing. It can be loaded by moments and forces in any direction. Rigidity and running accuracy can be influenced by a change in the preload.

The advantages and characteristics of an enclosed configuration:

- Supports any operation positions, load directions and moment loads
- Supports a small guideway base
- Must be preloaded. Consequently, rigidity and accuracy are increased.

#### An example involving linear guideways of type R, RN or RNG

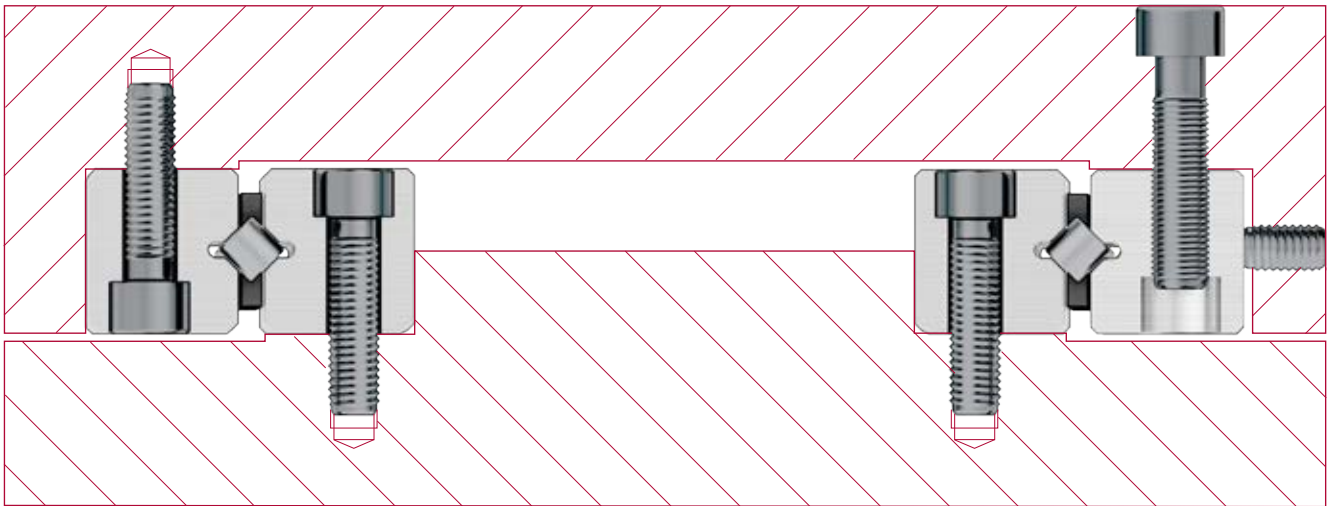

#### An example involving linear guideways of type N/O or M/V

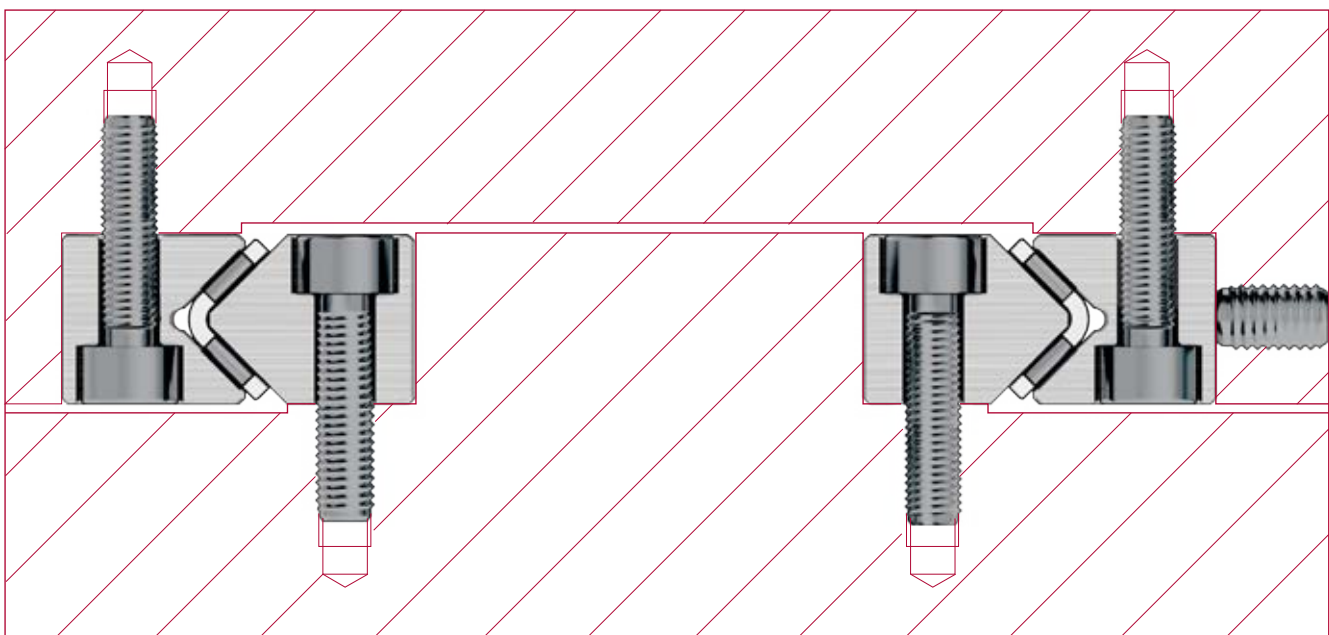

Sold & Serviced By:

 **ELECTROMATE**

Toll Free Phone (877) SERV098

Toll Free Fax (877) SERV099

[www.electromate.com](http://www.electromate.com)

[sales@electromate.com](mailto:sales@electromate.com)

# 13 Construction and installation guidelines

Example with recirculating units of type SK, SKD, SKD or SR combined with the double V-shaped guide RD

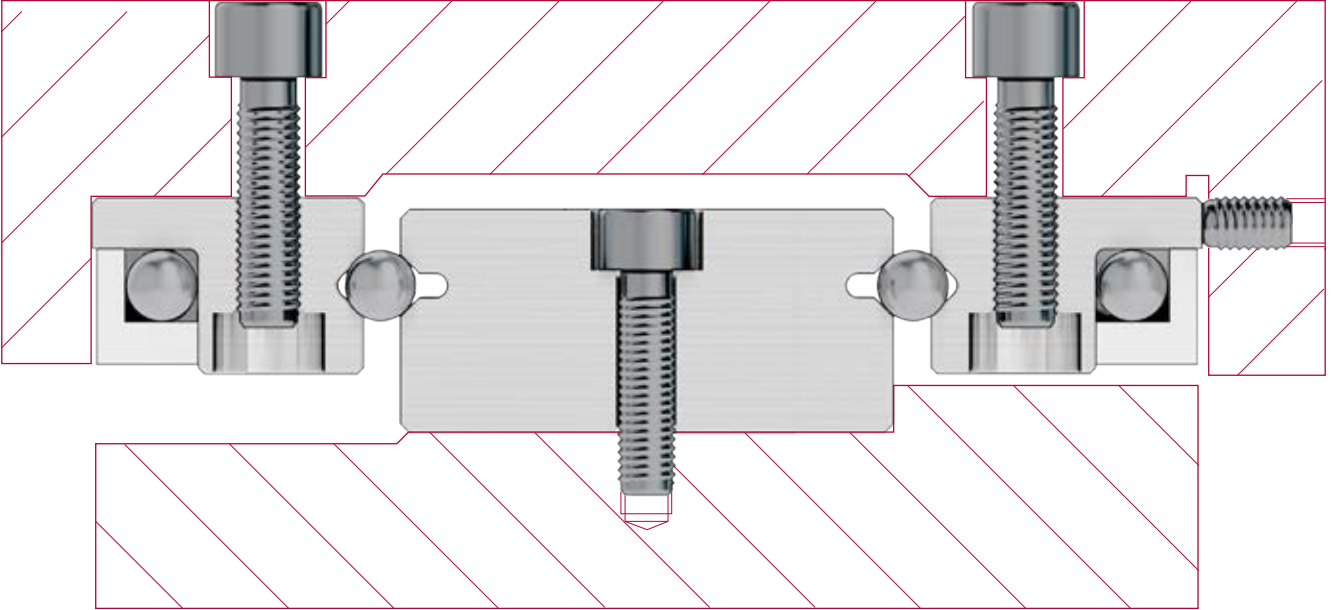

Example involving recirculating unit of type SK and linear guideways of type R

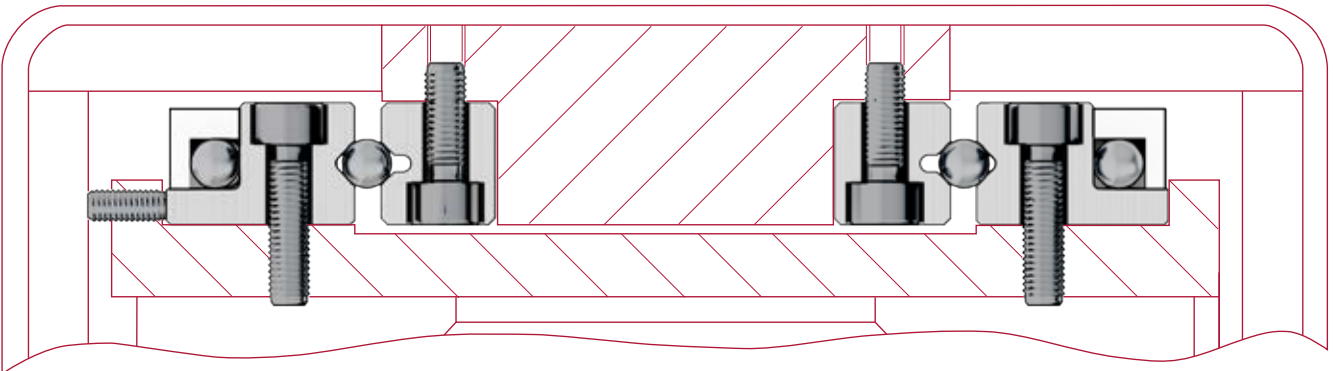

Example involving recirculating unit of type NRT and surface guideways

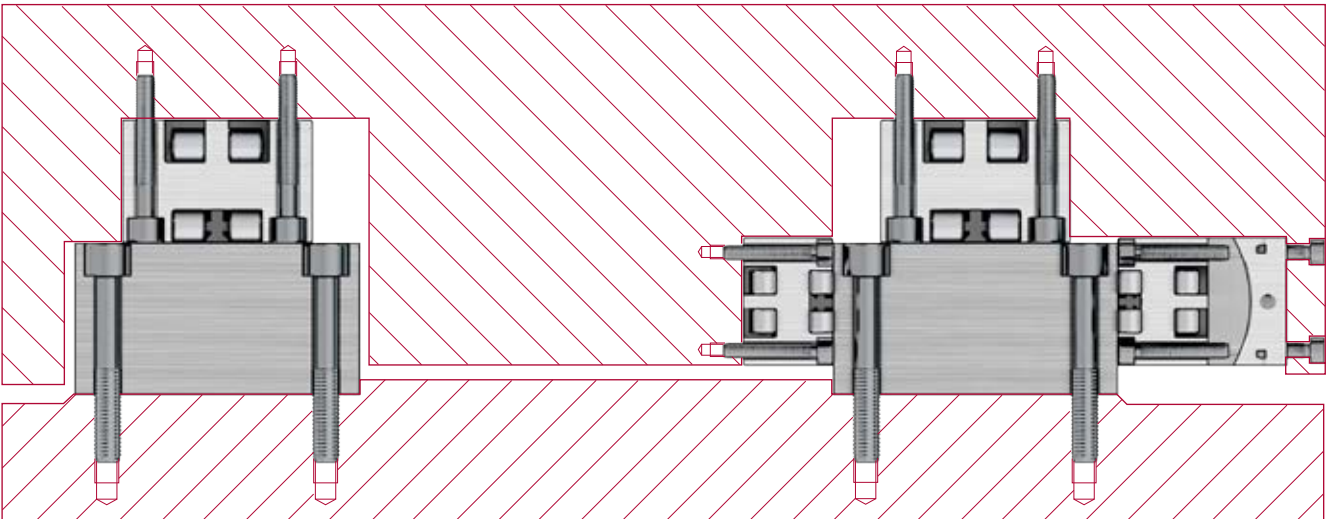

## 13 Construction and installation guidelines

### Open configuration

The open configuration is a fixed/loose bearing offering the following advantages and characteristics:

- Is mainly used when the load acts centrally and vertically on to the guideway plane and no deformations may occur by tensioning the surrounding structure.
- Thermal lateral variations are evened out
- Large bearing spans can easily be bridged
- Requires a large guideway base
- Very installation-friendly as the machine component can easily be seated and/or lifted off

**Example involving linear guideways of type R, RN or RNG combined with a surface guideway. In the case of open configurations, the height A for both pairs of guideways must be height-matched (see chapter 7.5).**

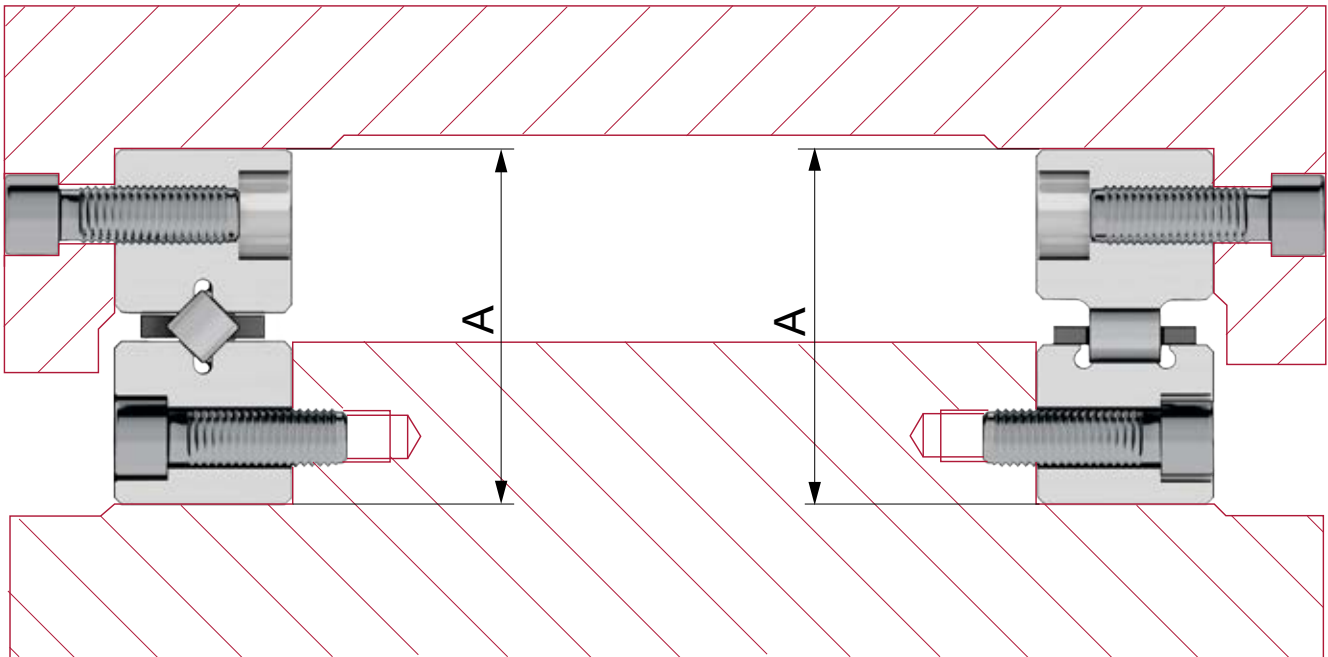

# 13 Construction and installation guidelines

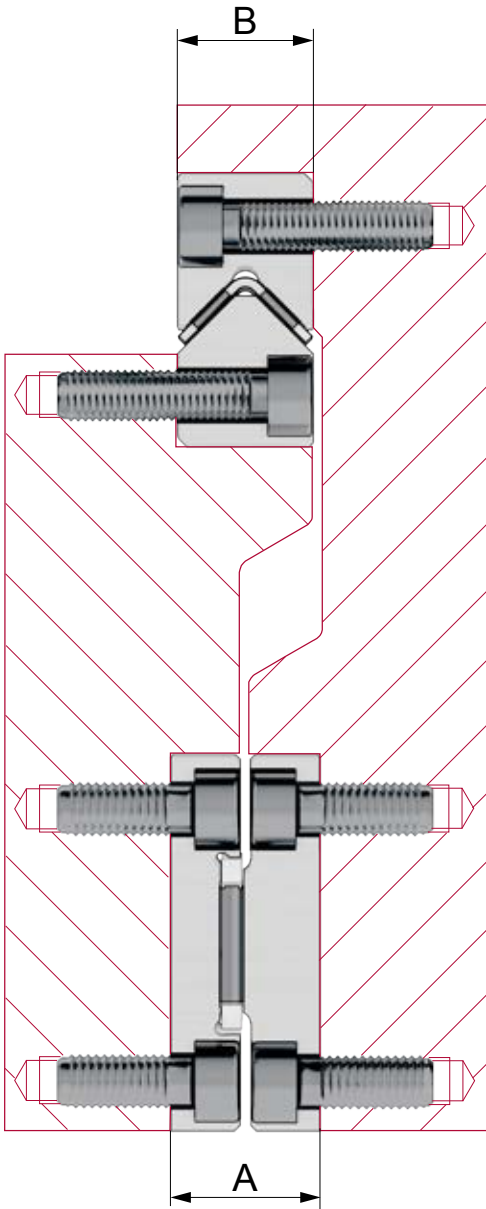

Example of a suspended linear guideway of type N/O or M/V combined with a surface guideway. The dimensions A and B must be height-matched.

Example involving recirculating unit of type NRT The vertical load is born by height-matched NRT

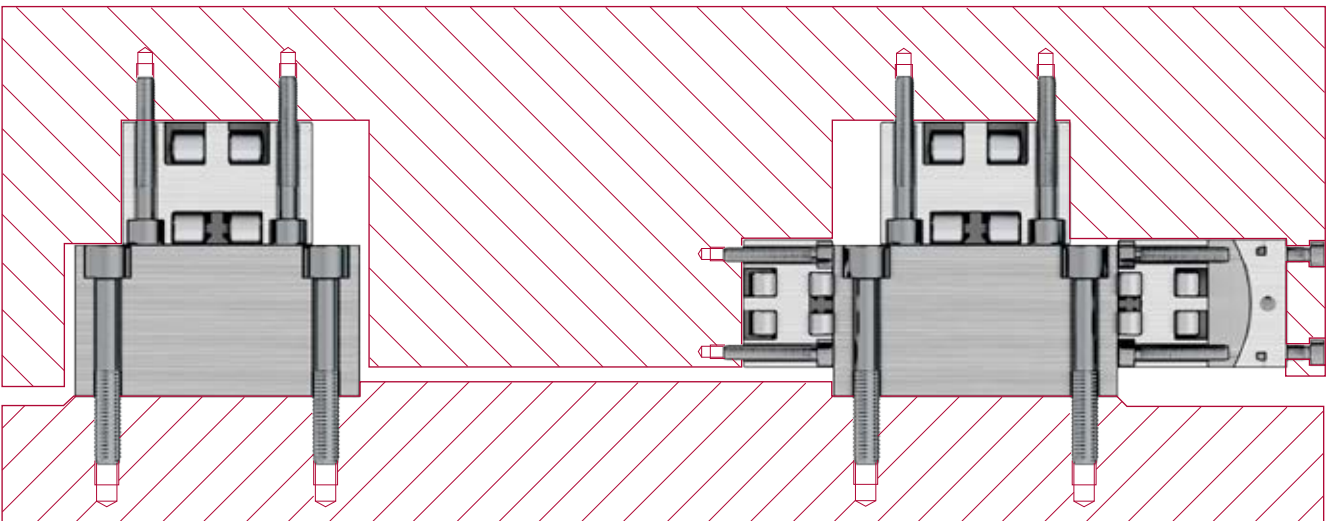

## 13 Construction and installation guidelines

### 13.4 Fastening

#### Fastening variants

The SCHNEEBERGER linear guideways and recirculating units can be fastened to the connecting structure in two different ways:

**A The use of the tapped boreholes**

**B The use of through holes**

Method A is preferred because a powerful fastening is possible based on the screw size

Method B provides added flexibility combined with the fastening screws with a thin shaft (see chapter 5).

#### Linear guideways

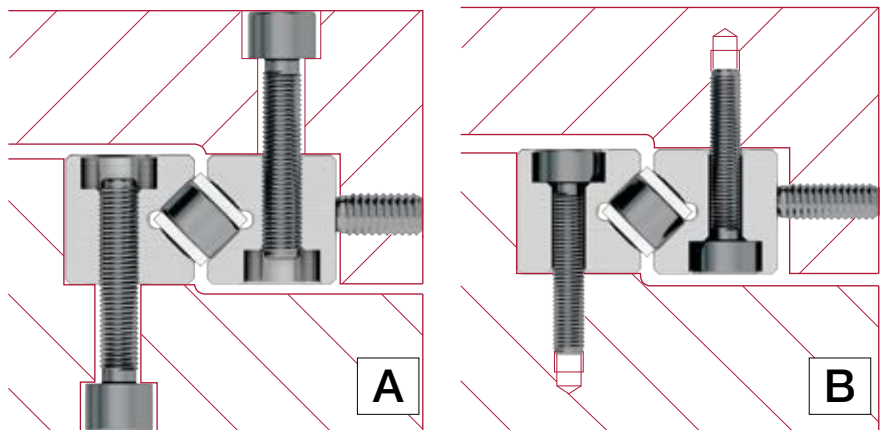

#### Recirculating units

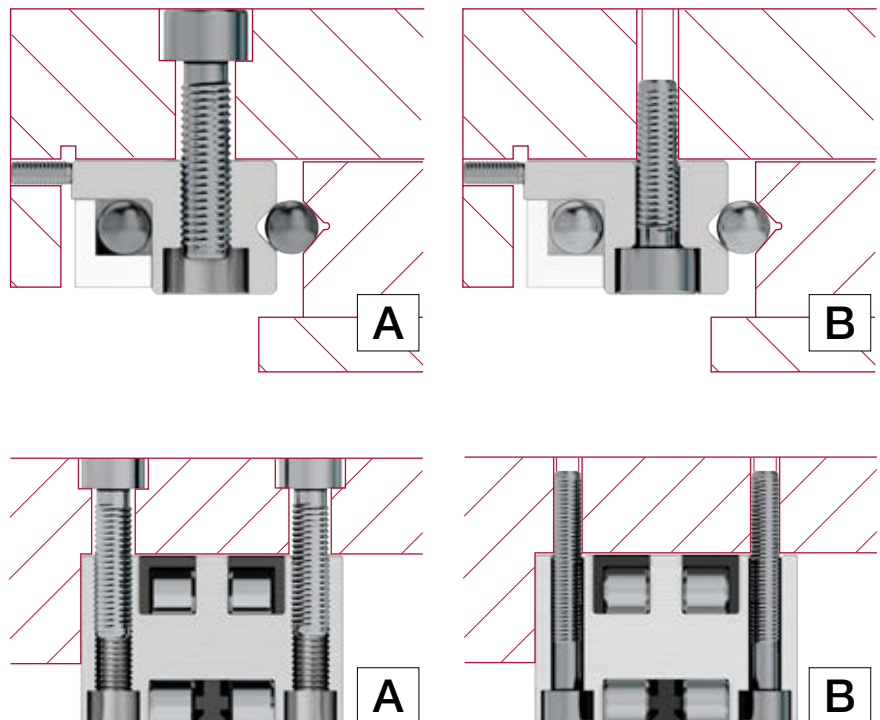

# 13 Construction and installation guidelines

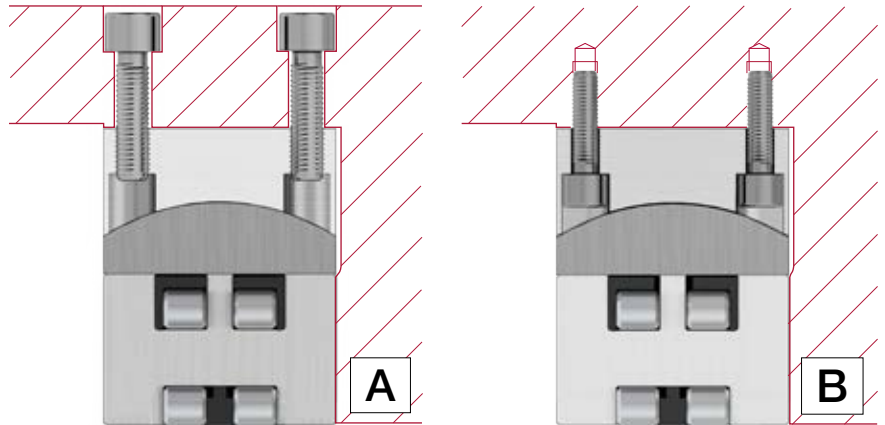

## Tightening torque settings for fastening screws

The recommended tightening torque settings can be found in the table. These values apply in respect of oiled screws.

By using greases containing MoS<sup>2</sup>, the required torque can drop to half of the values set out below.

Strength grade 8.8

Sizes	Tightening torque in Ncm	
	Fastening screws DIN 912	Fastening screws with thin shaft, type GD or GDN
M 2	35	28
M 2.5	73	58
M 3	128	102
M 4	290	232
M 5	575	460
M 6	990	792
M 8	2'400	1'920
M 10	4'800	3'840
M 12	8'300	6'640
M 14	13'200	10'560
M 16	20'000	--

## 13 Construction and installation guidelines

### 13.5 Preload

The size of the preload is guided by the intended use of the guideways. A high preload ...

- ... increases rigidity of the guideway and guarantees zero-backlash
- ... reduces moment loads, maximum loads on the rolling element
- ... increases displacement resistance
- ... reduces the service life

A positive effect of preload is achieved with 5 % - 20 % of the permissible load C.

#### General approach

The preload can be consistently set using a torque wrench. In so doing the friction between screw and tapped fixing hole must be taken into account (to be determined by means of tests).

When using wedge adjusters or adjusting plates, the ideal preload must be determined based on the elastic total deformation  $\delta_A$  (see chapter 12.5) and the deformation of the connecting structure.

When setting an R-guideway with cage type EE, the cage must first be slightly compressed before the rollers are applied.

As mentioned above, the preload increases the rigidity of the guideway. A high preload, however, requires a stable connecting structure. Otherwise unwanted edge loads occur to rollers and needles as a result of angular errors, which in turn has a negative impact on load carrying capacity.

#### Procedure for linear guideways

A guideway is normally set with zero-backlash using adjusting screws. A zero-backlash, uniform sequence is only achieved when advancing exclusively takes place where the cage with the rolling elements is located (see also chapter 13.9).

A linear guideway is normally set with zero-backlash using adjusting screws. At least one adjusting screw must be provided per fastening screw, the thread size of which should match the fastening screw. In the case of overrunning cages, the shorter rail should preferably be advanced.

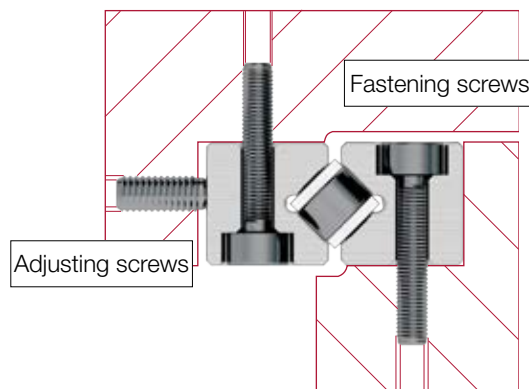

## 13 Construction and installation guidelines

Example calculation for the infeed force per adjusting screw (Pvs) of their tightening torque (Mds)

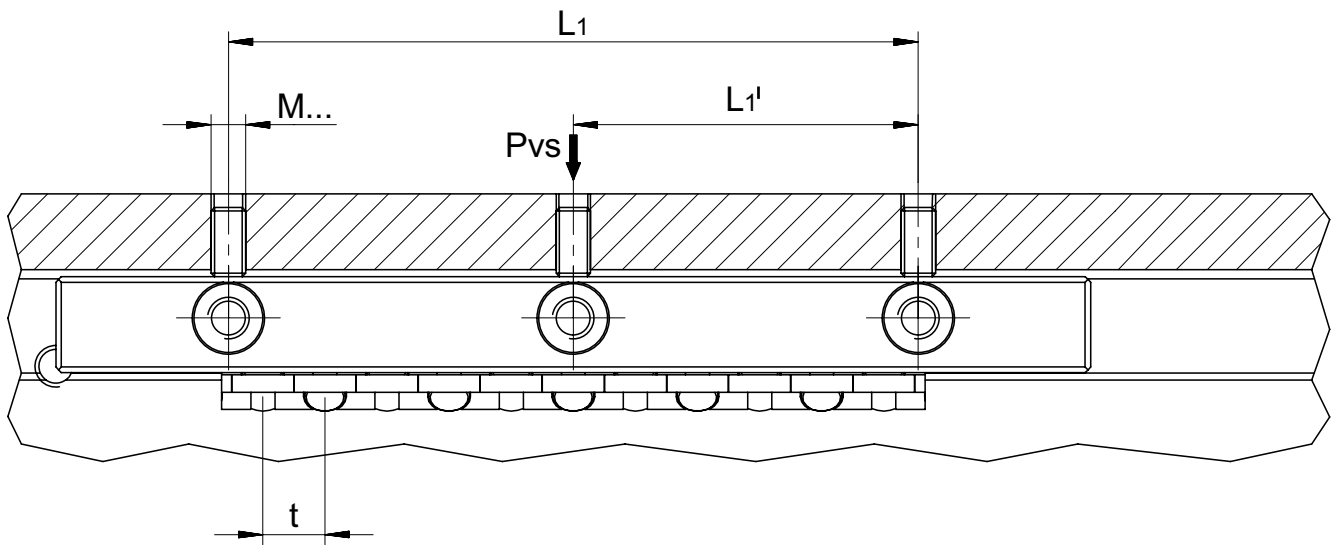

Required information per calculation:

- Linear guide type R 3
  - Roller cage type AC 3
  - Diameter of the adjusting screw
  - Factor f ("1" for roller, "2" for balls)
  - Preload p (5 % to 20 % of C)
  - Factor a in cm
- $L1' = 25 \text{ mm}$   
 $t = 5 \text{ mm}$   
 $C = 130 \text{ N}$   
 $= \text{M4}$   
 $= 1$   
 $= 10\%$   
 as per the following table

Thread	M2	M2.5	M3	M4	M5	M6	M8	M10	M12	M14	M16
Factor a	0.0238	0.0294	0,035	0.0469	0,058	0.0699	0.0926	0.1152	0.1378	0.1591	0.1811

Calculation of the infeed force per adjusting screw Pvs

$$P_{vs} = L_1' / t \cdot C \cdot p / 100 \cdot f$$

$$= 25 / 5 \cdot 130 \cdot 10 / 100 \cdot 1 = 65 \text{ N}$$

Calculation of tightening torque Mds

$$M_{ds} = P_{vs} \cdot a$$

$$= 65 \cdot 0.0469 = 3.05 \text{ Ncm}$$



## 13 Construction and installation guidelines

Other technical possibilities for preloading linear guideways include:

Setting using an **adjusting strip**

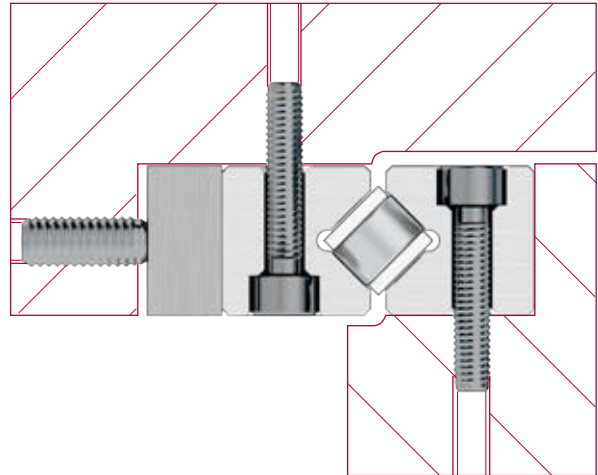

Setting using an **wedge adjuster**

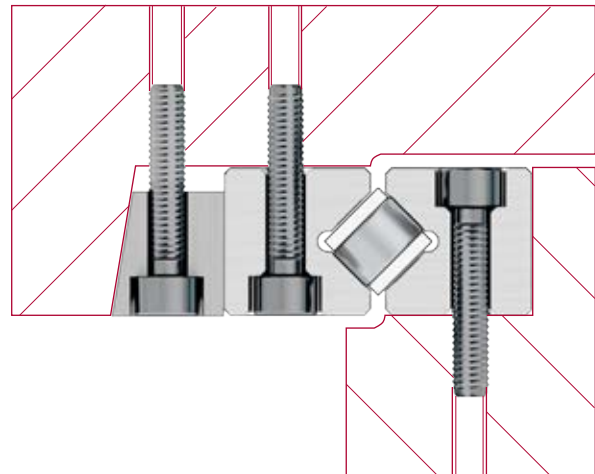

Setting using an **cylinder adjuster**

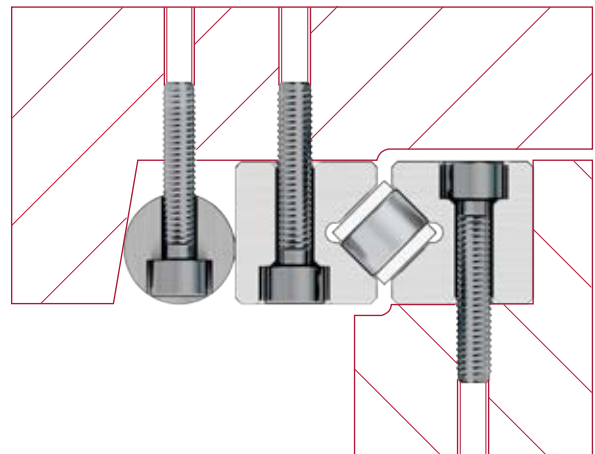

# 13 Construction and installation guidelines

Setting using a **longitudinal wedge**

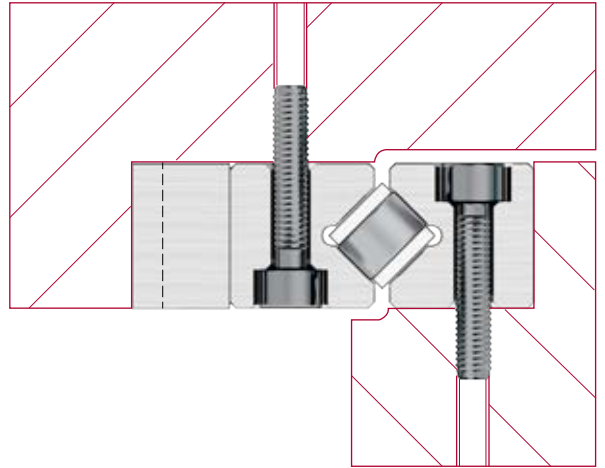

Setting using a **double longitudinal wedge**

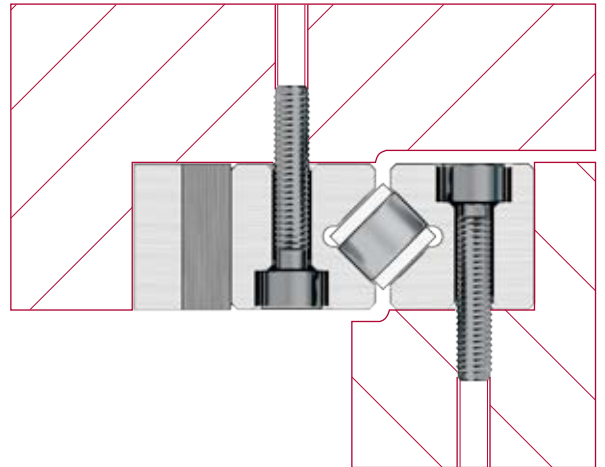

## 13 Construction and installation guidelines

Procedure when preloading recirculating units (SK, SKD, SKC and SR)

A recirculating unit is normally set with zero-backlash using adjusting screws. At least one adjusting screw must be provided per fastening screw, the thread size of which should match the fastening screw.

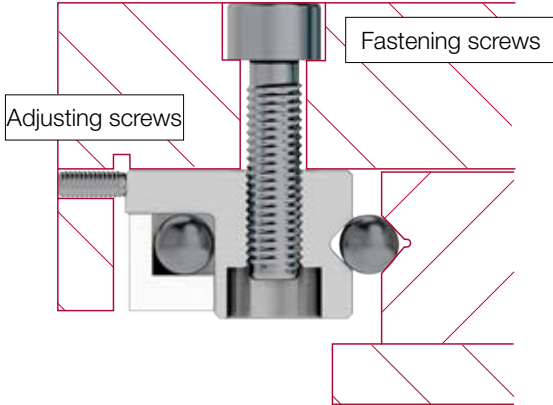

Example calculation for the infeed force per adjusting screw (Pvs) of their tightening torque (Mds)  
Required information per calculation:

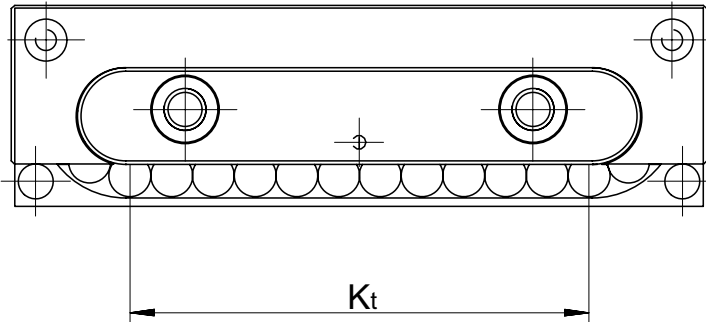

- Recirculating unit SK 6-100 C = 715 N
- Diameter of the adjusting screw = M4
- Number of adjusting screws N = 2
- Factor f ("1" for roller, "2" for balls) = 2
- Preload p (5 % to 20 % of C) = 10%
- Factor a in cm as per the following table

Thread	M2	M2.5	M3	M4	M5	M6	M8	M10	M12	M14	M16
Factor a	0.0238	0.0294	0,035	0.0469	0,058	0.0699	0.0926	0.1152	0.1378	0.1591	0.1811

Calculation of the infeed force per adjusting screw Pvs

$$Pvs = C / N \cdot p / 100 \cdot f$$

$$= 715 / 2 \cdot 10 / 100 \cdot 2 = 71.5 \text{ N}$$

Calculation of tightening torque Mds

$$Mds = Pvs \cdot a$$

$$= 71.5 \cdot 0.0469 = 3.35 \text{ Ncm}$$

Its advance must always remain within the load-bearing length  $K_t$ !

# 13 Construction and installation guidelines

Procedure for recirculating unit NRT with preload wedge type NRV

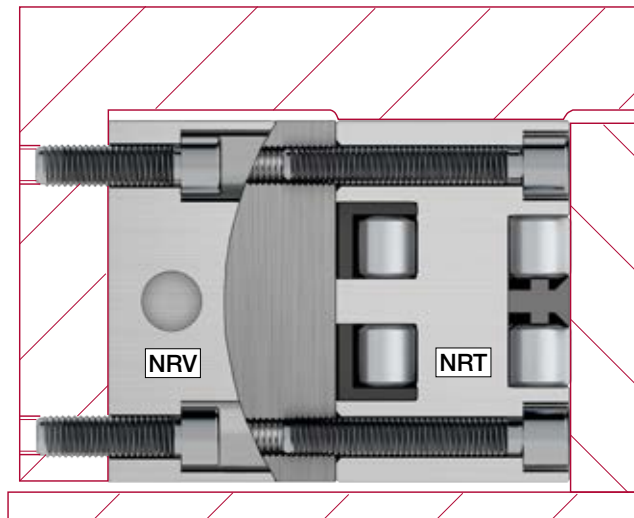

For preload using preload wedge NRV the following infeed values apply:

Type	Size	Max adjustment range in terms of height (mm)	Height difference per revolution of the preload screw A
NRV	19'077	0.35	0.0350
	26'111	0.40	0.0625
	26'132	0.40	0.0625
	38'144	0.40	0.0750

After successfully setting the preload, always tighten the two lock nuts alternately and using the wrench applying the same amount of torque!

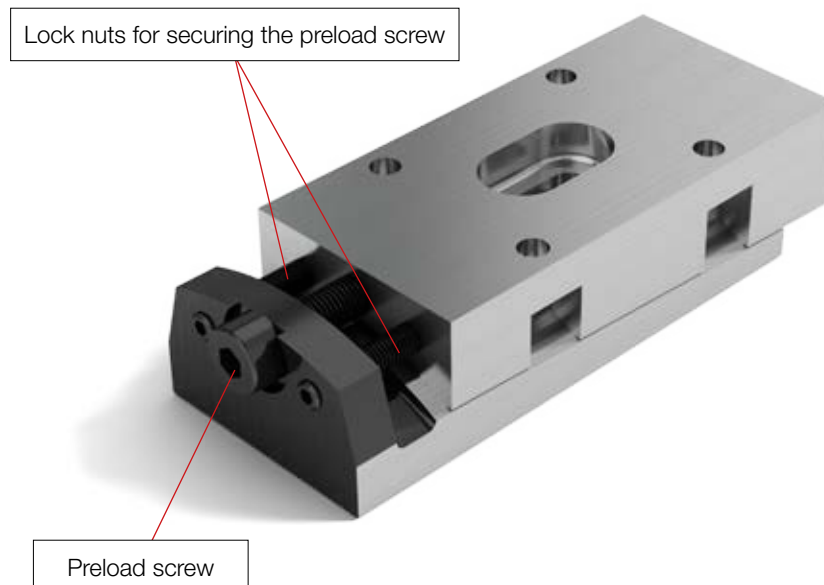

## 13 Construction and installation guidelines

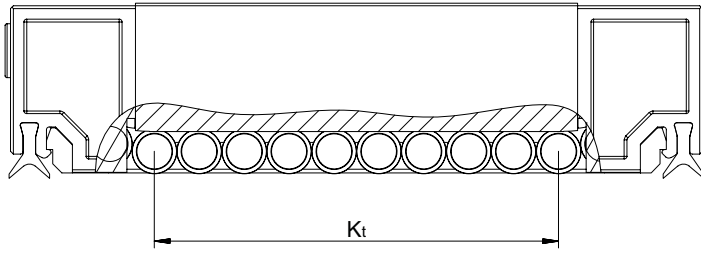

If preloading takes place without preload wedge NRV it is important to ensure that the advance must always remain within the load-bearing length  $K_t$ .

Other technical possibilities for preloading the NRT include:

Setting using an **intermediate plate**

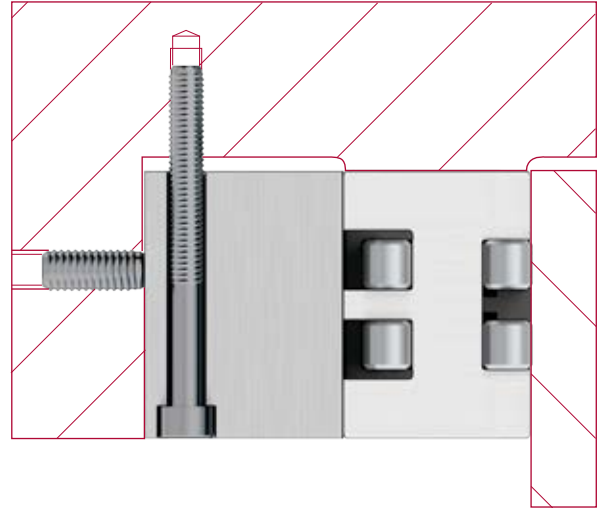

Setting using a **wedge adjuster**

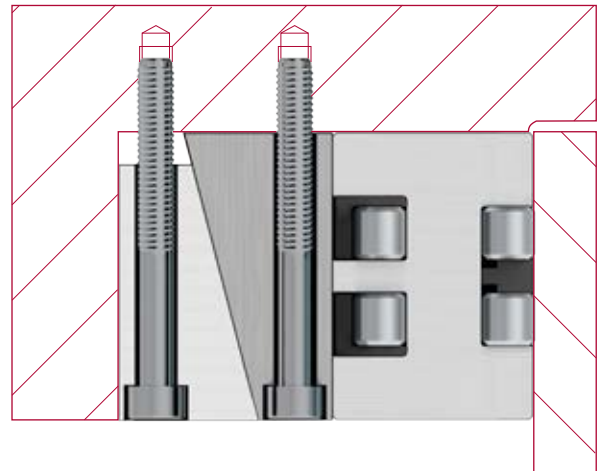

Setting using a **double longitudinal wedge**

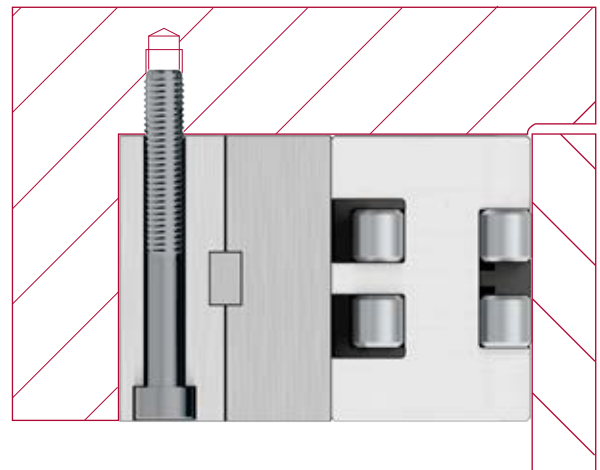

## 13 Construction and installation guidelines

### 13.6 Sealing and covers

The method of sealing or covering is significant for the smooth operation and service life of the guideways.

Where there is only a small amount of dirt, wipers are sufficient to keep the tracks clean. Their braking effect can generally remain unattended. As standard different wipers are available, which are described in detail in the respective product specifications.

Covers are used when there is some danger of harmful contamination of the guideway. While wipers only push the dirt off the running surfaces in the area of their movement, covers provide the opportunity of also keeping penetrating dirt away at the sides.

Some design options are listed below:

A = Wiper sideways

B = Diverting swarf and coolant away using a cover

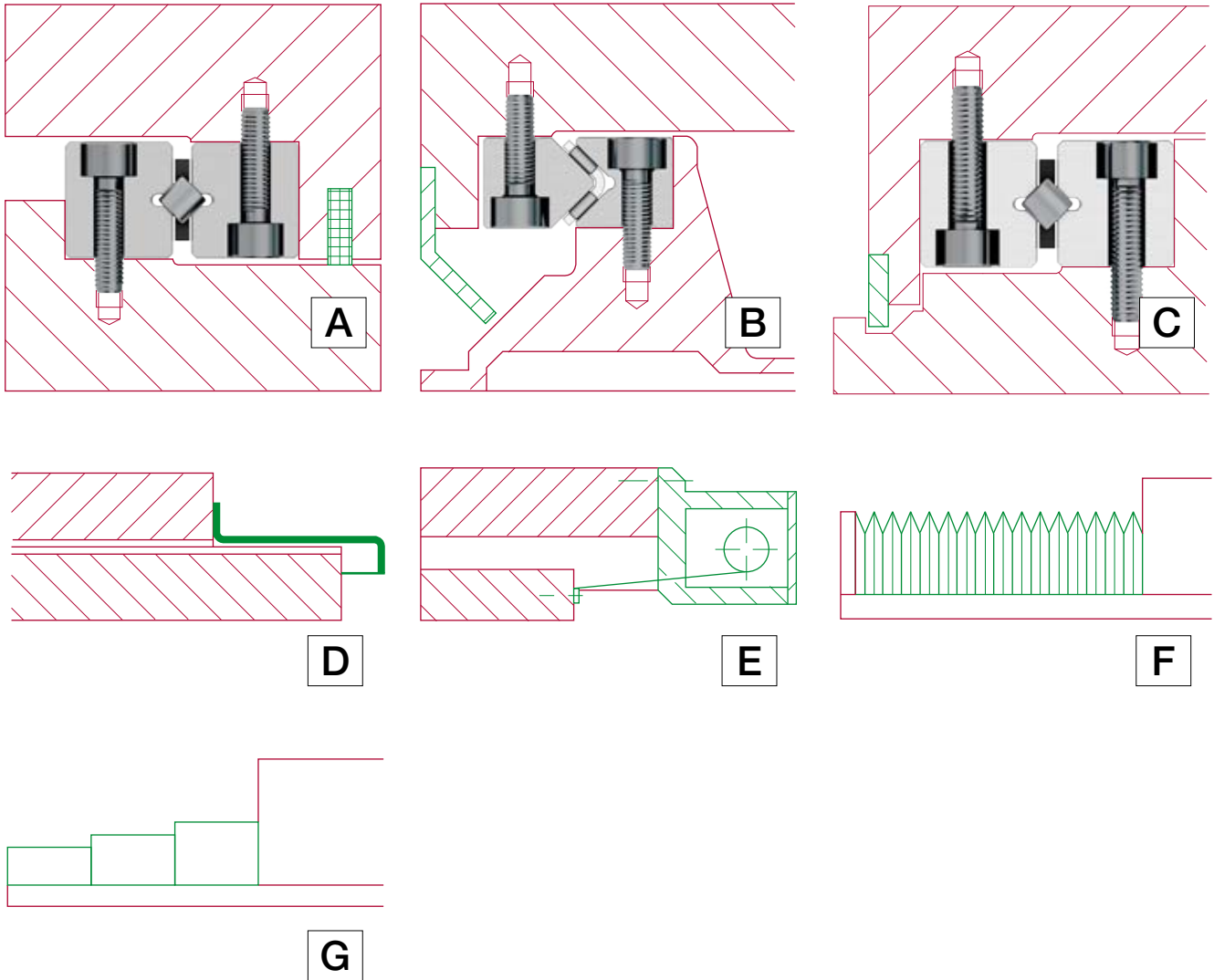

C = Labyrinth seals offer an effective and economically viable protection

D = Simple metal cover

E = Roll-up cover

F = Bellows above or below

G = Telescopic cover

Generating excess pressure can also help to prevent dirt accumulating. The excess pressure must also be maintained, however, during working breaks.

## 13 Construction and installation guidelines

### 13.7 Lubrication

Lubrication is a design element and must therefore be defined during the development phase of a machine or application. If the lubrication is only selected after design and construction is complete, based on experience this is likely to lead to considerable difficulties. A carefully thought out lubrication concept is therefore a sign of a state-of-the-art and well devised design.

Parameters to be taken into account in selecting the lubricant, amongst others, include:

- Operating conditions (speed, accelerations, stroke, load, installation orientation)
- External influences (temperature, aggressive media or radiation, dirt accumulating, moisture)
- Subsequent lubrication (period of time, quantity, compatibility with other lubricants)
- Compatibility (with corrosion protection, with integrated materials such as plastic cages)
- Tracks (geometry, surface roughness, hardness, material, coating, wettability)

Technical and economic considerations determine the lubricant and process to be used. Generally lithium-soap-based roller bearing grease are used to lubricate (alloyed greases KP2K in accordance with DIN 51502 or DIN 51825). Oil dispensers or occasional oiling via oil nipples fully meet the demands of the guideways. For minimal roller frictional resistance lubrication with mineral-oil-based oils is recommended (CLP or HLP in viscosities of ISO VG 15 to 100 in accordance with DIN 51519).

The lubricants are normally applied through the spacing between the linear guideways and the recirculating units or through the lubrication holes in some instances available as standard or lube nipples in the recirculating units. If this is not supported by the design (e.g. in the case of vertical installation), on request linear guideways with lube holes can also be supplied. Particularly advantageous are oil mist lubrication methods, which help to prevent dirt accumulating on the guideways with their slight excess pressure. Their acceptability is greatly limited, however, due to their environmental impact. Cutting-oils or water soluble coolants are to be kept away from the guideways, however, because they dilute or wash away the available lubricant. In addition, coolants tend to stick when drying out. Lubricants with solid additives are inappropriate.

**Subsequent lubrication intervals** depend on the aforementioned operating conditions and external influences and cannot be therefore be calculated. That is why the lubrication point must be observed over a lengthy period of time.

Values based on historical experience show that with normal use subsequent lubrication of up to 2 to 5 times is sufficient, spread over the calculated service life.

## 13 Construction and installation guidelines

### Lubrication of the recirculating unit NRT

There are three ways of lubricating the NRT

**Variant A:** Lube nipple on each end face

**Variant B:** Lube opening on the top

**Variant C:** Optional connection for a centralised lubricating system

**Variant A:** Lubrication by means of the lube nipple

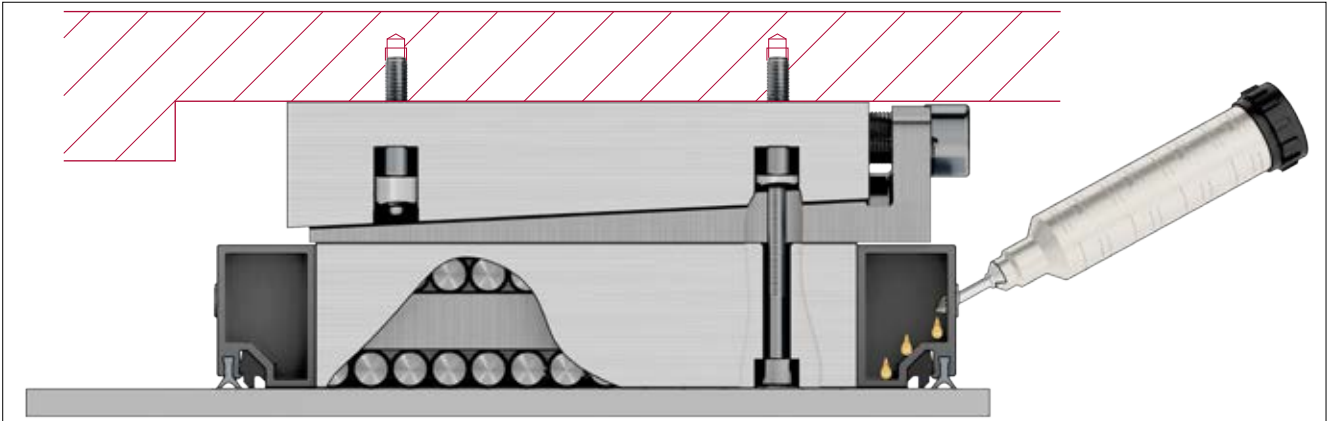

### Variants B:

Oil delivery through the lube opening on the top

Oil delivery through the lube opening on the top through the preload wedge NRV

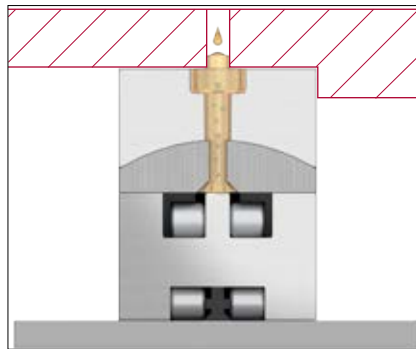
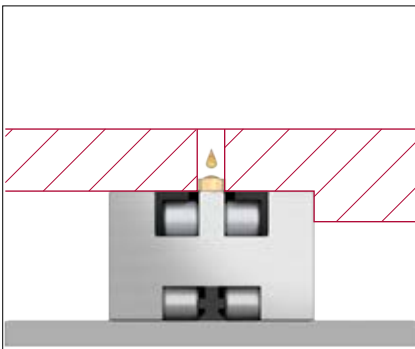

**Variant C:** Centralised lubricating system (option ZS)

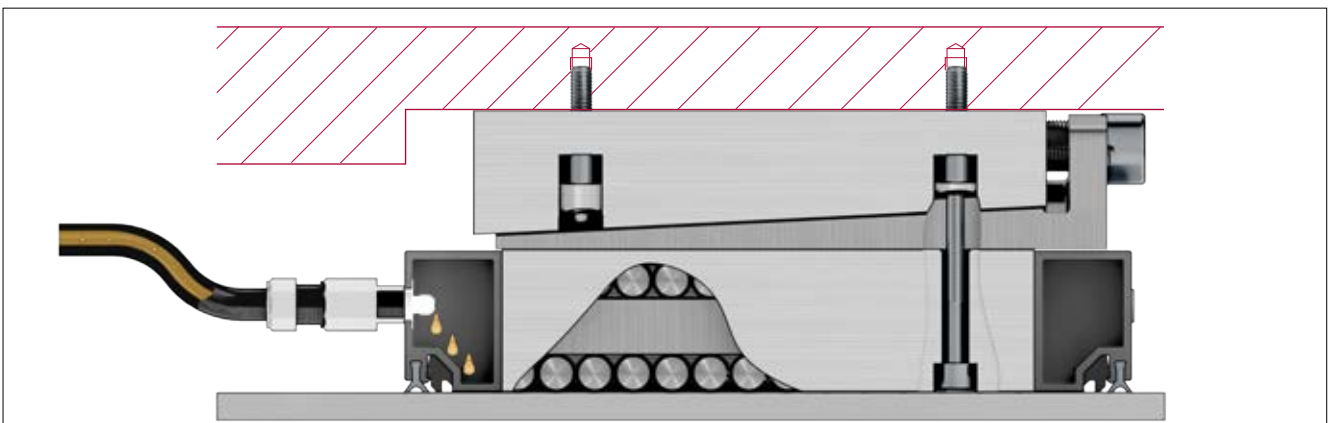



## 13 Construction and installation guidelines

### 13.8 Transport, handling and storage

Linear guideways and recirculating units are high-precision components and should therefore be handled with care. They should always be transported in their original packaging to protect them from damage and be stored at room temperature and in a dry environment.

Improper handling of the guideways can lead to preliminary damage and thus to premature failure. That is why their assembly may only be undertaken by expert professional staff.

### 13.9 Installation guidelines

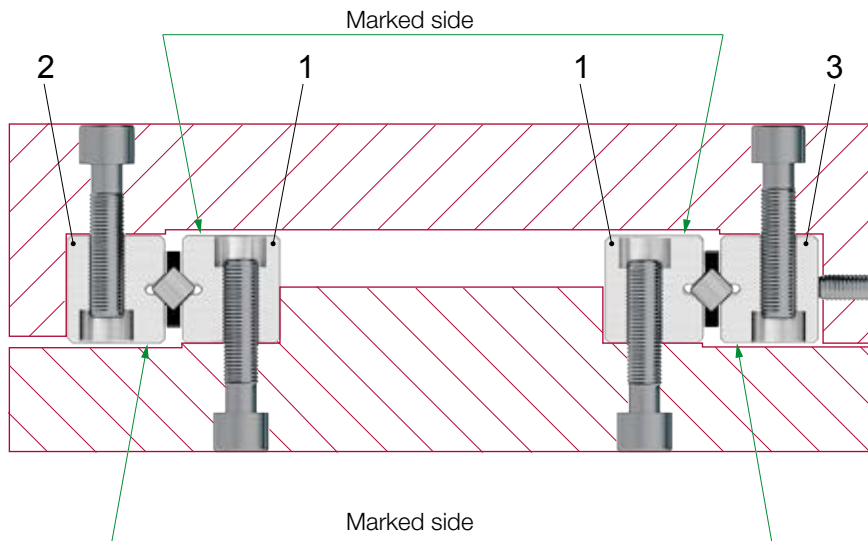

#### Linear guideways

With careful, clean preparation and a step by step approach, by adopting a rational procedure you will achieve a perfect guide system.

The following installation instructions applies by analogy for all types of SCHNEEBERGER linear guideways.

- To guarantee a perfect support for the guide rails, any remaining burrs or ridges are to be removed with a fine whetstone.
- Before installation the linear guideways and supporting surfaces are to be cleaned. By means of a subsequent light lubrication they will be protected from any consequential damage.

Tip for long or multi-part guide rails:

Due to the bore hole tolerances of the rails, the fastening holes in the supporting surfaces should be drilled according to the holes in the linear guideways. By using fastening screws with a thin shaft differences in hole spacings can also be evened out (see chapter 5).

- The marked side of the guide rail may not be used as a supporting surface!
- The fixed pair of linear guideways (1) is pressed against the supports using an appropriate clamping element and the fastening screws are tightened (use a torque wrench! For tightening torque see page 125.)

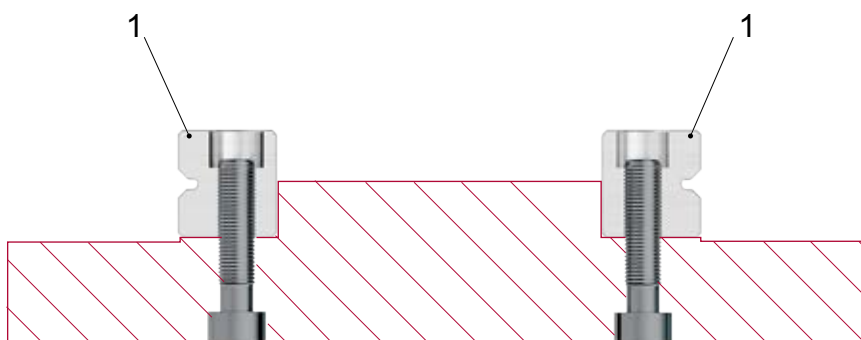

## 13 Construction and installation guidelines

- Check parallelism  $\Delta A$  and  $\Delta P$ . The parallelisms measured must fall within the tolerances of the linear guideway (see chapter 7.1)

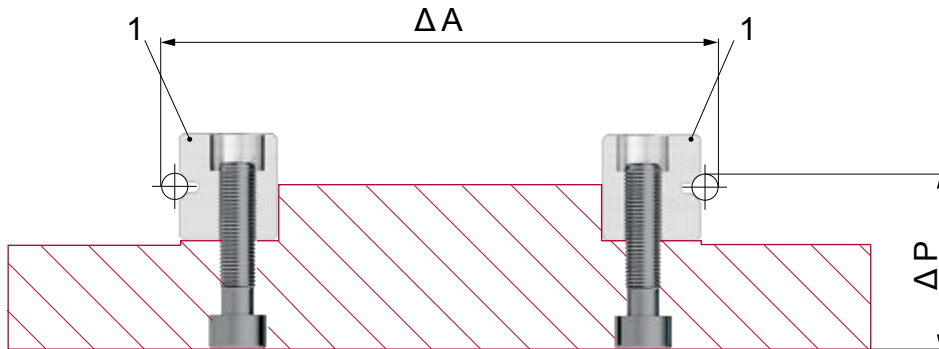

- Install the fixed rail (2) of the opposing pair.

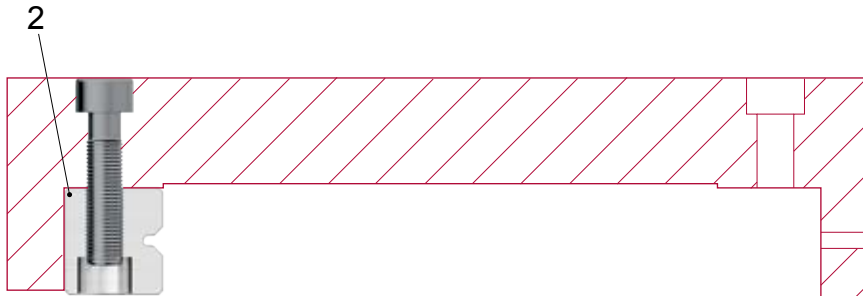

- Install the rail (3) and in so doing only lightly tighten the fastening screws.
- Lubricating (see chapter 13.7)

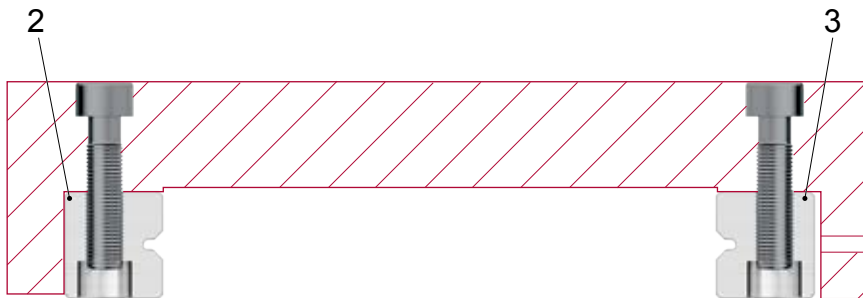

- Insert and center the cages (4). After that the linear bearings must be preloaded (please refer to the following page).

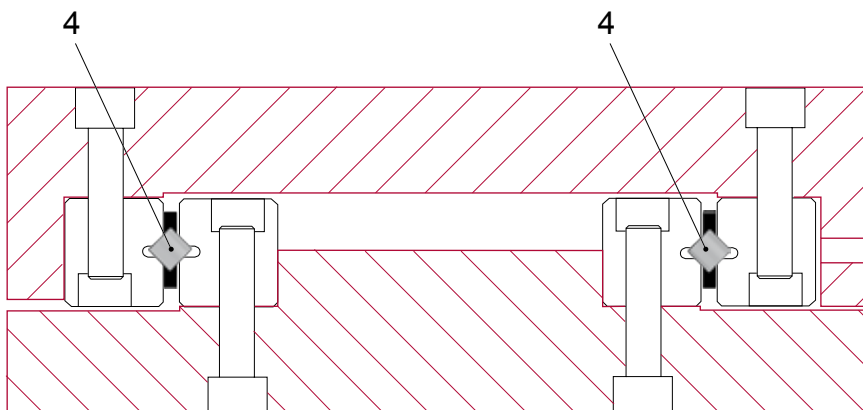

## 13 Construction and installation guidelines

- Set and/or preload the linear guideway with zero-backlash (see chapter 13.5).

Application of the preload using the adjusting screws should be carried out from the centre of the rail outwards using the following steps (the sequence can be worked out from the figures):

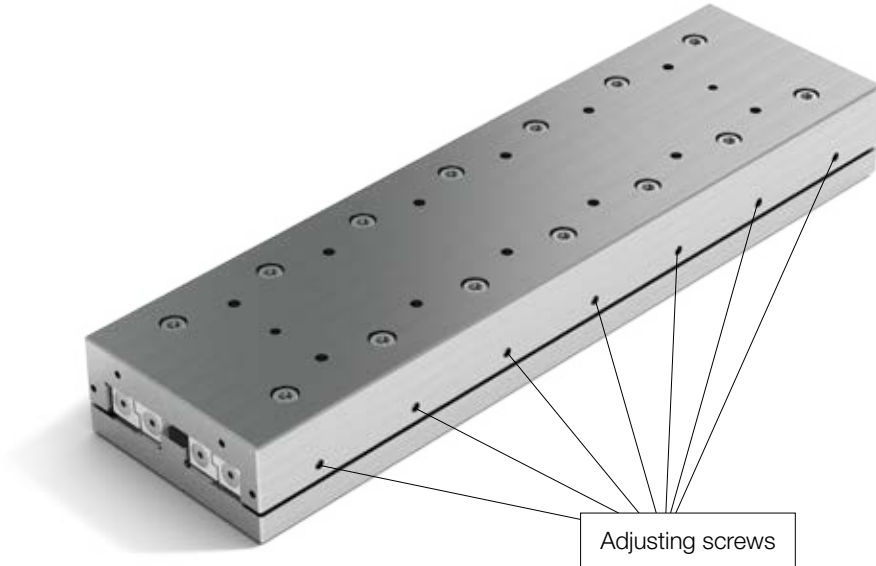

1. Step

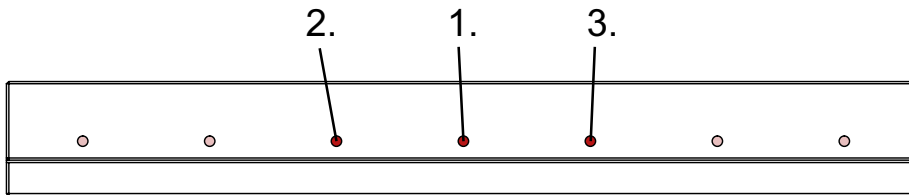

2. Step

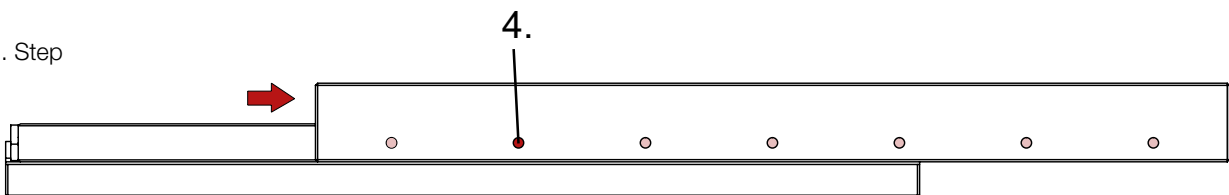

3. Step

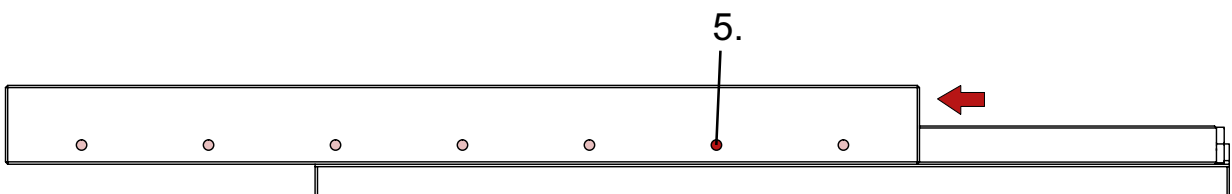

# 13 Construction and installation guidelines

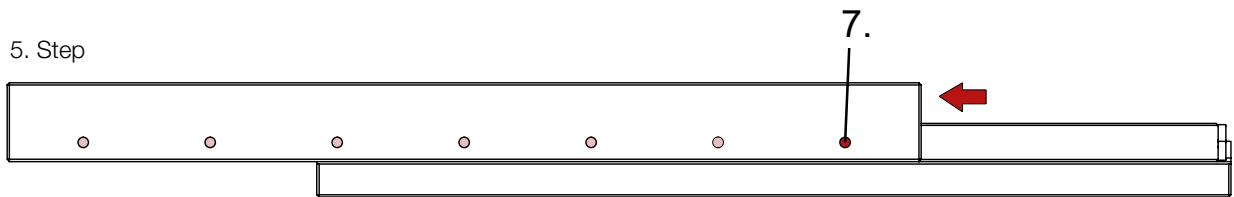
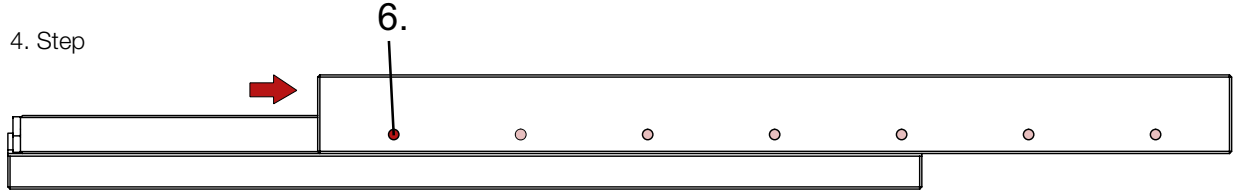

- Tighten the fastening screws for the rail (3).

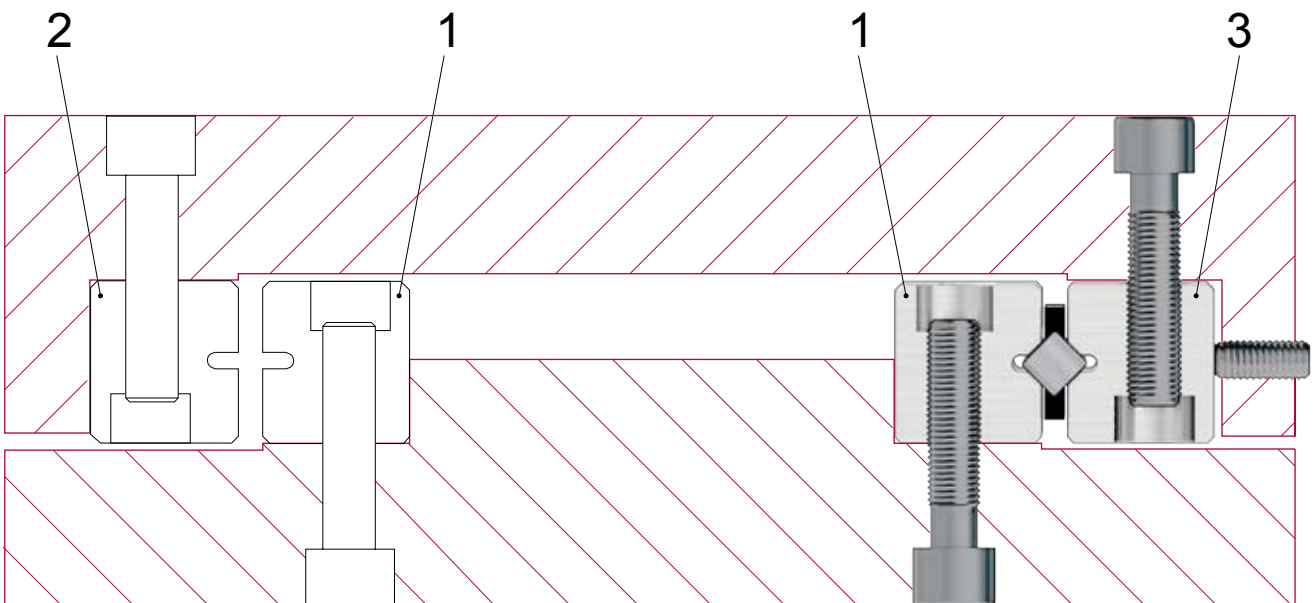

- Install the end pieces

# 14 Order descriptions

## Examples for linear guideways



Example 1	Quantity	Type and size	Length in mm	Options
Guide rails	80	RNG 6	- 300	-SSQ-KS-RF
Cage	40	KBS 6 x 20*		

Example 2	Quantity	Type and size	Length in mm	Options
Guide rails	20	R 9	- 800	
Guide rails	20	R 9	- 600	-EG
Cage	20	AC 9 x 22*		
End pieces	40	GC 9		

\* corresponds to the number of rolling elements

Note: In the case of cage types HW and SHW the cage length must be indicated in mm! (e.g. SHW 20 x 155 mm.)

## Example recirculating unit

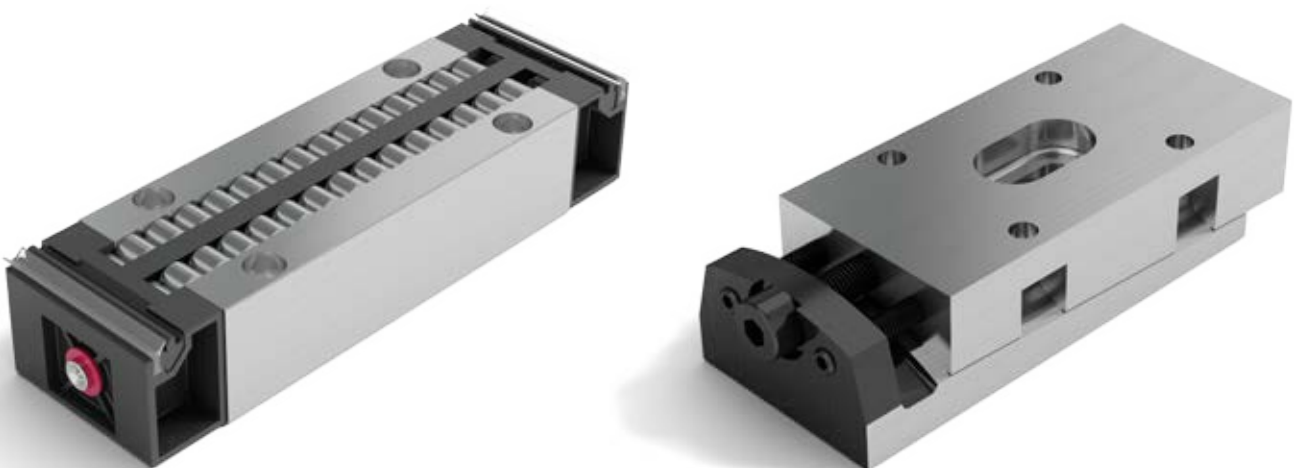

	Quantity	Type and size	Options
Recirculating units	150	NRT 26111	-GP
Preload wedge	150	NRV 26111	