

# Temposonics®

Magnetostrictive, Absolute, Non-contact  
Linear-Position Sensors



**R-Series**  
Rod Model RS

**Document Part Number**  
**551251 Revision A**

## Data Sheet



**Model RS Rod-style sensor with IP68/IP69K Super Shield Housing**

### FEATURES

- Robust Sealed Housing IP68/IP69K
- Analog, SSI, DeviceNet, Profibus, EtherCAT and CANbus Outputs

### BENEFITS

- Available for R-Series Rod-Style Sensors
- Rugged Industrial Sensor
- Linear, Absolute Measurement
- Non-Contact Sensing Technology

### APPLICATIONS

- Ideal For Hydraulic and Pneumatic Cylinders in Wash Down Environments
- Continuous Operation In Harsh Industrial Conditions
- Additional Protection for Exposed Outdoor Environments

### TYPICAL INDUSTRIES

- Fluid Power
- Material Handling and Packaging
- Valve and Gate Positioning

### Time-based Magnetostrictive position sensing principle

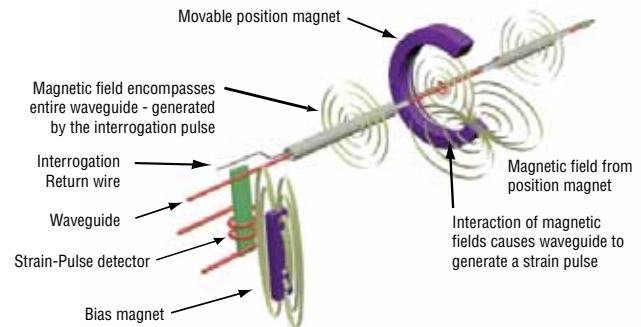

### Benefits of Magnetostriction

Temposonics linear-position sensors use the time-based magnetostrictive position sensing principle developed by MTS. Within the sensing element, a sonic-strain pulse is induced in a specially designed magnetostrictive waveguide by the momentary interaction of two magnetic fields. One field comes from a moveable permanent magnet that passes along the outside of the sensor. The other field comes from an “interrogation” current pulse applied along the waveguide. The resulting strain pulse travels at sonic speed along the waveguide and is detected at the head of the sensing element.

The position of the magnet is determined with high precision and speed by accurately measuring the elapsed time between the application of the interrogation pulse and the arrival of the resulting strain pulse with a high-speed counter. The elapsed time measurement is directly proportional to the position of the permanent magnet and is an absolute value. Therefore, the sensor's output signal corresponds to absolute position, instead of incremental, and never requires recalibration or re-homing after a power loss. Absolute, non-contact sensing eliminates wear, and guarantees the best durability and output repeatability.

Sold & Serviced By:



Toll Free Phone (877) SERV098  
Toll Free Fax (877) SERV099  
www.electromate.com  
sales@electromate.com

## Product Overview and Specifications

### Product overview

The extremely robust Temposonics® Rod-style Model RS sensor with super shield housing ensures long-term linear position measurement in the harshest environments. Hermetically sealed with a housing completely made of stainless steel, it meets protection modes IP68 and IP69K requirements and are reliably shielded against corrosion and penetration of dirt and water.

Due to non-contact measuring technology, sensor integration into a hermetically sealed housing is possible. A position magnet moves along the outside of the pressure-resistant sensor pipe and marks the position without mechanical contact.

For level measurement, an optional float can be used. The modular sensor cartridge design enables the customer to choose the specific sensor output configurations to be installed within the super shield housing to best fit their application requirements. The measuring accuracy and all technical data correspond to the features of the sensor selected inside the housing.

A wide choice of interfaces (Analog, Profibus, SSI, CANbus, DeviceNet, and EtherCAT) is available. Moreover, integration of ATEX-certified and intrinsically safe sensors is possible with the protective housing. For specific information, refer to the specific R-Series sensor data sheet.

Temposonics® Model RS sensors are made to fit Temposonics® R-Series with analog and digital outputs. Fixed cable and connector versions can be used on the sensor side. When using standard sensors in this housing, you get a cost efficient solution for use in rugged applications. Several design combinations are available to fit your application: M18 or 3/4" UNF mounting flange thread, various housing lengths, and single, dual or triple cable glands.

Serial communication and a simple PC-based user interface enable remote sensor programmability and diagnostics without the need to compromise the housing's protection rating. These features can be used to simplify machine design, sensor setup and field programming.

### Product specifications

Consult the individual R-series sensor data sheet for product specifications and ordering information at [www.mtssensors.com](http://www.mtssensors.com)

Parameters	Specifications
<b>OUTPUT</b>	
<b>Outputs:</b>	Analog, SSI, Profibus, EtherCAT, CANbus, and DeviceNet
<b>Stroke length:</b>	<b>Range (Rod style):</b> 50 mm to 7620 mm (2 in. to 300 in.)
<b>ENVIRONMENTAL</b>	
<b>Operating conditions:</b>	<b>Operating temperature:</b> -40 °C (-40 °F) to +75 °C (+167 °F) <b>Relative humidity:</b> 100% <b>Sealing:</b> IP68/IP69K
<b>EMC test:</b>	<b>Electromagnetic emission:</b> IEC/EN 50081-1 <b>Electromagnetic susceptibility:</b> IEC/EN 50082-2, IEC/EN 61000-4-2/3/4/6, level 3/4 criterium A, CE qualified
<b>Shock rating:</b>	100 g (single hit)/IEC standard 68-2-27 (survivability)
<b>Vibration rating:</b>	15 g / 10 to 2000 Hz / IEC standard 68-2-6
<b>FORM FACTOR MATERIAL (MODEL RS)</b>	
<b>Electronic head:</b>	303/304 stainless steel or 304L (1.4404) on request
<b>Sensor rod:</b>	303/304 stainless steel or 304L (1.4305) on request
<b>Operating pressure:</b>	350 bar static, 690 bar peak (5000 psi static, 10,000 psi peak)
<b>Mounting:</b>	Any orientation. Threaded flange M18 x 1.5 or 3/4 - 16 UNF-3A
<b>Typical mounting torque:</b>	45 N-m (33 ft. - lbs.)
<b>Magnet types:</b>	Ring magnet, open-ring magnet, or magnet float

Sold & Serviced By:



Toll Free Phone (877) SERV098  
Toll Free Fax (877) SERV099  
[www.electromate.com](http://www.electromate.com)  
[sales@electromate.com](mailto:sales@electromate.com)

## Model RS rod-style sensor dimension reference

The Temposonics R-Series rod-style sensor (Model RS) offers modular construction, flexible mounting configurations, and easy installation. The Model RS sensor is designed for mounting in applications where high pressure conditions exist, (5000 psi continuous, 10,000 psi spike), such as inside hydraulic cylinders. The Model RS sensor may also be mounted externally in many applications.

### MODEL RS, ROD-STYLE SENSOR WITH IP68/IP69K HOUSING

Drawing is for reference only, contact applications engineering for tolerance specific information.

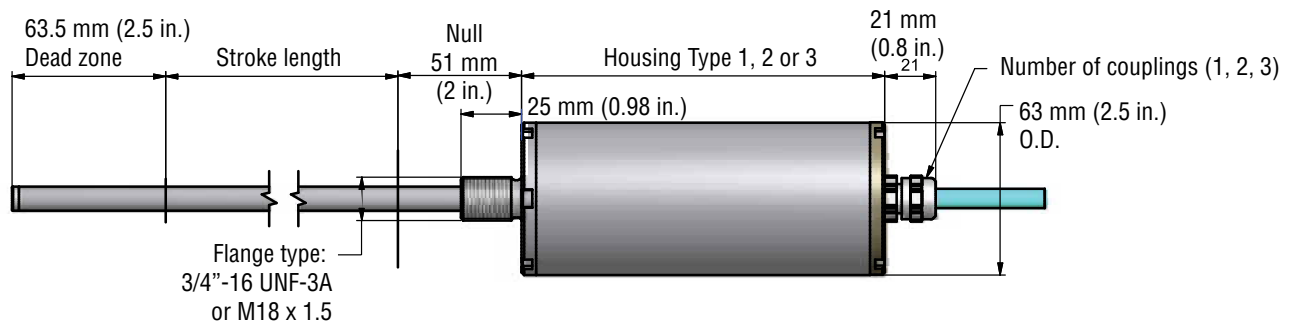

Figure 1. Model RS Rod-style sensor dimension reference. (See Figures 5, 6 and 7 for cable gland exits)

### MODEL RS, ROD-STYLE SENSOR WITH TYPE 1 HOUSING

Drawing is for reference only, contact applications engineering for tolerance specific information.

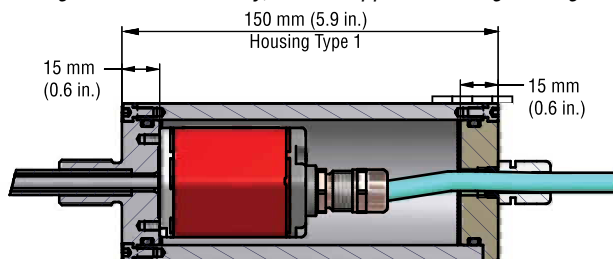

Figure 2. Model RS Rod-style sensor dimension reference (shown with **Type 1** housing)

### MODEL RS, ROD-STYLE SENSOR WITH TYPE 2 HOUSING

Drawing is for reference only, contact applications engineering for tolerance specific information.

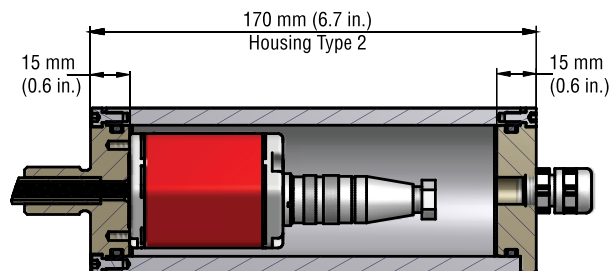

Figure 3. Model RS Rod-style sensor dimension reference (shown with **Type 2** housing)

### MODEL RS, ROD-STYLE SENSOR WITH TYPE 3 HOUSING

Drawing is for reference only, contact applications engineering for tolerance specific information.

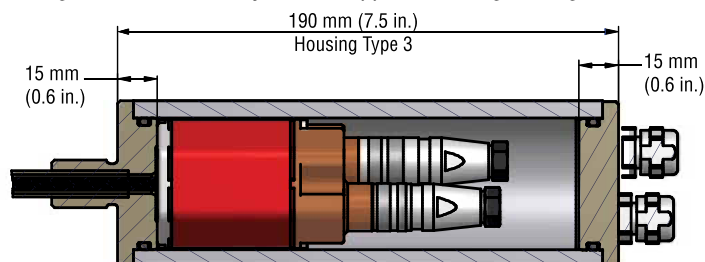

Figure 4.

Sold & Serviced By:



Toll Free Phone (877) SERV098

Toll Free Fax (877) SERV099

www.electromate.com

sales@electromate.com

## Model RS Rod-Style Sensor Cable Gland Exits

Single, dual or triple cable glands are required for your specific R-Series Rod-style sensor selection (as shown in Figures 5, 6 and 7). Consult the R-Series Sensor Data Sheet for specific connection, wiring and mounting information.

### MODEL RS, ROD-STYLE SENSOR CABLE GLAND EXITS

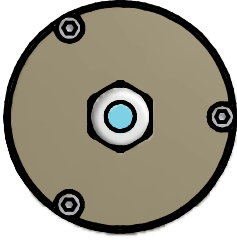

Figure 5. Model RS Rod-style sensor (shown with *Single* cable gland exit)

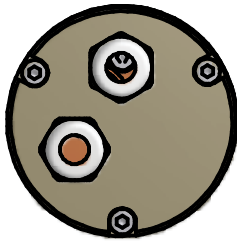

Figure 6. Model RS Rod-style sensor (shown with *Dual* cable gland exit)

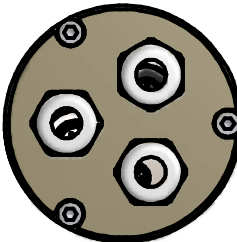

Figure 7. Model RS Rod-style sensor (shown with *Triple* cable gland exit)

Sold & Serviced By:

 **ELECTROMATE**

Toll Free Phone (877) SERV098

Toll Free Fax (877) SERV099







[www.electromate.com](http://www.electromate.com)

[sales@electromate.com](mailto:sales@electromate.com)

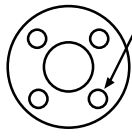
## Standard magnet selections (Model RS)

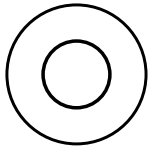
Magnets must be ordered separately with Model RS position sensors. The standard ring magnet (part number 201542-2) is suitable for most applications.

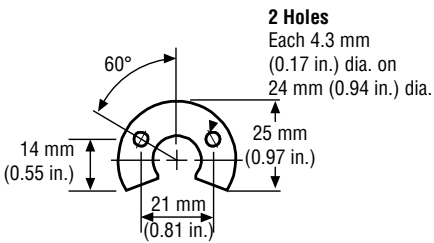
### POSITION MAGNET SELECTIONS (Magnet must be ordered separately) (Drawing dimensions are for reference only)

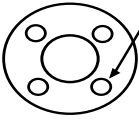
Magnet and magnet dimensions	Description	Part number
  <p><b>4 Holes</b> Each 4.3 mm (0.17 in.) dia. 90° apart on 24 mm (0.94 in.) dia.</p>	<p><b>Standard ring magnet</b> I.D.: 13.5 mm (0.53 in.) O.D.: 33 mm (1.3 in.) Thickness: 8 mm (0.3 in.) Operating temperature: - 40 °C to 100 °C</p>	201542-2
 	<p><b>Ring magnet</b> I.D.: 13.5 mm (0.53 in.) O.D.: 25.4 mm (1 in.) Thickness: 8 mm (0.3 in.) Operating temperature: - 40 °C to 100 °C</p>	400533
  <p><b>2 Holes</b> Each 4.3 mm (0.17 in.) dia. on 24 mm (0.94 in.) dia.</p>	<p><b>Open-ring magnet, Style M</b> I.D.: 13.5 mm (0.53 in.) O.D.: 33 mm (1.3 in.) Thickness: 8 mm (0.3 in.) Operating temperature: - 40 °C to 100 °C</p> <p>This magnet may influence the sensor performance specifications for some applications.</p>	251416-2
  <p><b>4 Holes</b> Each 4.3 mm (0.17 in.) dia. 90° apart on 24 mm (0.94 in.) dia.</p>	<p><b>Magnet spacer</b> (Non-ferrous, use with ring magnet Order number: 201542-2) I.D.: 14 mm (0.56 in.) O.D.: 32 mm (1.25 in.) Thickness: 3.2 mm (0.125 in.)</p>	400633

### MAGNET FLOAT SELECTION (Drawing dimensions are for reference only)

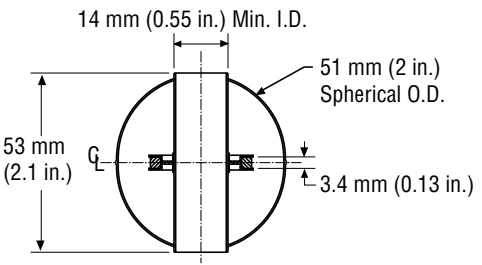
  <p>14 mm (0.55 in.) Min. I.D. 51 mm (2 in.) Spherical O.D. 53 mm (2.1 in.) 3.4 mm (0.13 in.)</p>	<p><b>Magnet float</b> (Level sensing applications) Specific gravity: 0.70 maximum Pressure: 870 psi maximum</p> <p>(This float is used with the Model RS Rod-style sensors for hydraulic fluid or fresh water applications only)</p>	251447
--	---	--------

## Models RS Sensors Ordering Information

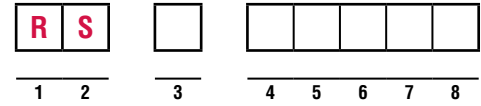

**SENSOR MODEL** \_\_\_\_\_ = 

R	S
---	---

**1-2**

**RS** = Rod style sensor with Super Shield Housing

**PRESSURE PIPE FLANGE** \_\_\_\_\_ = 

--

**3**

**M** = Flange M18 x 1.5                      **S** = Flange 3/4 in. -16 UNF - 3A

**STROKE LENGTH** \_\_\_\_\_ = 

--	--	--	--	--

**4-8**

\_\_\_\_ **M** = Millimeters  
(Encode in 5 mm increments)

\_\_\_\_ **U** = Inches and tenths  
(Encode in 0.1 in. increments)

**Stroke Length Notes:**

Rod-style sensor (model RS) stroke range = 50 mm (2 in.) - 7620 mm (300 in.)

**SENSOR PARAMETERS**

Refer to the individual R-Series data sheet to complete the order number beyond position '8' for outputs: Analog, SSI, CANbus, DeviceNet, Profibus and EtherCAT.