

# Temposonics®

Magnetostrictive, Absolute, Non-contact  
Linear-Position Sensors



**R-Series Models RP and RH**  
Synchronous Serial Interface (SSI) Output

Document Part Number  
550989 Revision E

## Data Sheet



**Model RP Profile-style position sensor**

**Model RH Rod-style position sensor**

### FEATURES

- Linear, Absolute Measurement
- LEDs For Sensor Diagnostics
- Non-Contact Sensing Technology
- Non-Linearity Less Than 0.01%
- Repeatability Within 0.001%
- Direct 24/25/26 Bit SSI Output, Gray/Binary Formats
- Synchronous Measurement for Accurate Velocity/Acceleration Calculations

### BENEFITS

- Superior Accuracy; Resolution Down to 0.5 Micron
- Rugged Industrial Sensor
- High-Speed Update Options
- Linearity Correction Options
- Velocity Output Option
- Optional Differential Measurement Between Two Magnets

### APPLICATIONS

- Continuous Operation In Harsh Industrial Conditions
- High Pressure Conditions
- For Fast, Precision Motion Control

### TYPICAL INDUSTRIES

- Factory Automation
- Fluid Power
- Plastic Injection and Blow Molding
- Material Handling and Packaging
- Woodworking, Metalworking and Machine Tools

### Time-based Magnetostrictive position sensing principle

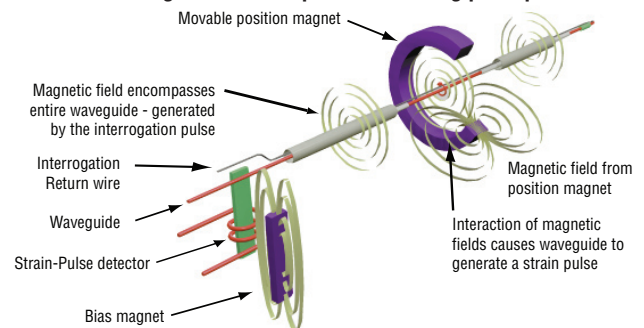

### Benefits of Magnetostriction

Temposonics linear-position sensors use the time-based magnetostrictive position sensing principle developed by MTS. Within the sensing element, a sonic-strain pulse is induced in a specially designed magnetostrictive waveguide by the momentary interaction of two magnetic fields. One field comes from a moveable permanent magnet that passes along the outside of the sensor. The other field comes from an "interrogation" current pulse applied along the waveguide. The resulting strain pulse travels at sonic speed along the waveguide and is detected at the head of the sensing element.

The position of the magnet is determined with high precision and speed by accurately measuring the elapsed time between the application of the interrogation pulse and the arrival of the resulting strain pulse with a high-speed counter. The elapsed time measurement is directly proportional to the position of the permanent magnet and is an absolute value. Therefore, the sensor's output signal corresponds to absolute position, instead of incremental, and never requires recalibration or re-homing after a power loss. Absolute, non-contact sensing eliminates wear, and guarantees the best durability and output repeatability.

Sold & Serviced By:



Toll Free Phone (877) SERV098  
Toll Free Fax (877) SERV099  
www.electromate.com  
sales@electromate.com

**Product overview**

R-Series model RH and RP sensors are extremely robust and are ideal for continuous operation under harsh industrial conditions. MTS offers two standard sensor housings, rod and profile extrusion. The rod housing is capable of withstanding high pressures such as those found in hydraulic cylinders. The profile extrusion housing provides convenient mounting options and captive-sliding magnets which utilize slide bearings of special material that reduce friction, and help mitigate dirt build up. The sensor head contains the active signal conditioning and a complete integrated electronics interface. Double shielding is used to ensure EMI protection for unsurpassed reliability and operating safety.

**Product specifications**

Parameters	Specifications	Parameters	Specifications
<b>OUTPUT</b>		<b>ENVIRONMENTAL</b>	
<b>Measured output variables:</b>	Position, or position difference between 2 magnets, or velocity, internal temperature	<b>Operating conditions:</b>	<b>Operating temperature:</b> -40 °C (-40 °F) to +75 °C (+167 °F) <b>Relative humidity:</b> 90% no condensation <b>Temperature coefficient:</b> < 15 ppm/ °C
<b>Resolution:</b>	0.5 µm, 1 µm, 2 µm, 5 µm, 10 µm, 20 µm, 50 µm, 100 µm	<b>EMC test:</b>	<b>Emissions:</b> IEC/EN 50081-1 <b>Immunity:</b> IEC/EN 50082-2 IEC/EN 61000-4-2/3/4/6, level 3/4 criterion A, CE qualified
<b>Update Rate</b>		<b>Shock rating:</b>	100 g (single hit)/ IEC standard 68-2-27 (survivability)
<b>Measuring length:</b>	300 750 1000 2000 5000 mm	<b>Vibration rating:</b>	15 g (30 g with HVR option)/ 10 to 2000 Hz, IEC standard 68-2-6 (operational)
<b>Measurements/Sec:</b>	3.7 3.0 2.3 1.2 0.5 kHz (Up to 10 kHz for high-speed update option)	<b>WIRING</b>	
<b>Non-linearity:</b>	< ± 0.01% full stroke, (minimum ± 40 µm) (Linearity Correction Option (LCO) available)	<b>Connection type:</b>	7-pin male D70 (M16) connector, 10-pin male MS connector or integral cable
<b>Repeatability:</b>	< ± 0.001% full stroke (minimum ± 2.5 µm)	<b>PROFILE STYLE SENSOR (MODEL RP)</b>	
<b>Hysteresis:</b>	< 4 µm (2 µm is typical)	<b>Electronic head:</b>	Aluminum housing with diagnostic LED display (LEDs located beside connector/cable exit)
<b>Outputs:</b>	<b>Interface:</b> Synchronous Serial Interface (SSI) (RS-422 type differential signal pairs) <b>Data format:</b> Binary or gray, optional parity and error bit, optional internal temperature. <b>Data length:</b> 8 to 32 bit <b>Data speed (Baud rate):</b> 70 kBd* to 1 MBd, depending on cable length (see below):	<b>Sealing:</b>	IP 65
<b>Length:</b>	<3 <50 <100 <200 <400 m	<b>Sensor extrusion:</b>	Aluminum (Tempsonics profile style)
<b>Baud rate:</b>	1.0 MBd <400 kBd <300 kBd <200 kBd <100 kBd	<b>Mounting</b>	Any orientation. Adjustable mounting feet or T-slot nut (M5 threads) in bottom groove
<b>Stroke length:</b>	<b>Range (Profile style):</b> 25 to 5080 mm (1 to 200 in.) <b>Range (Rod style):</b> 25 to 7620 mm (1 to 300 in.) <b>Range (Flexible style):</b> 255 to 10,060 mm (10 to 396 in.) (Contact factory for longer stroke lengths)	<b>Magnet types:</b>	Captive-sliding magnet or open-ring magnet
<b>Distance between magnets:</b>	75 mm (3 in.) minimum for 2 magnet differential output * With standard monoflop of 16 µs	<b>ROD STYLE SENSOR (MODEL RH)</b>	
<b>ELECTRONICS</b>		<b>Electronic head:</b>	Aluminum housing with diagnostic LED display (LEDs located beside connector/cable exit)
<b>Operating voltage:</b>	<b>+24 Vdc nominal:</b> -15% or +20% <b>Polarity protection:</b> up to -30 Vdc <b>Overvoltage protection:</b> up to 36 Vdc <b>Current drain:</b> 100 mA typical <b>Dielectric withstand voltage:</b> 500 Vdc (DC ground to machine ground)	<b>Sealing:</b>	IP 67 or IP 68 for integral cable models
		<b>Sensor rod:</b>	304L stainless steel
		<b>Operating pressure:</b>	350 bar static, 690 bar peak (5000 psi, 10,000 psi peak)
		<b>Mounting:</b>	Any orientation. Threaded flange M18 x 1.5 or 3/4 - 16 UNF-3A
		<b>Typical mounting torque:</b>	45 N-m (33 ft. - lbs.)
		<b>Magnet types:</b>	Ring magnet, open-ring magnet, or magnet float

### Synchronous Serial Interface (SSI)

Temposonics R-Series sensors with SSI fulfill all requirements of the SSI standard for an absolute encoder. The position value is encoded in a 24/25/26 code format and is transmitted at high speed in SSI standard format to the control device. The main feature of SSI is the synchronized data transfer. Data transfer synchronization simplifies the closed-loop control system.

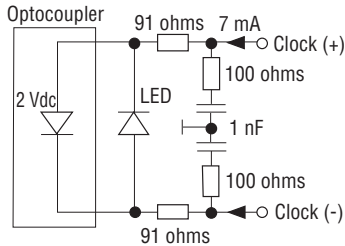

Figure 1. Sensor input

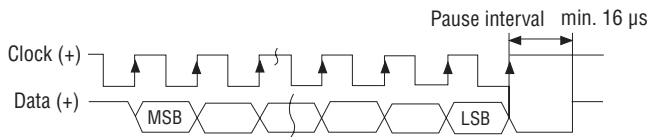

Figure 2. Timing Diagram

A clock pulse train from a controller is used to gate out sensor data. One bit of position data is transmitted to the controller for each clock pulse received by the sensor (see 'Figures 1 and 2'). The absolute position data is continually updated by the sensor and converted by the shift register into serial information. (see 'Figure 3').

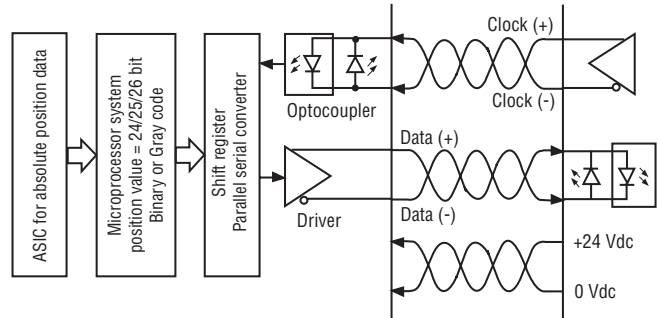

Figure 3. Logic Diagram

### Measuring Modes

#### THE SENSOR MEASUREMENT CYCLE

For all Temposonics position sensors, the measurement cycle begins with a very short electrical current pulse being applied to the sensor's waveguide. This is called the 'interrogation pulse'. It creates a magnetic field that interacts with another magnetic field emanating from the position magnet. This interaction produces the magnetostrictive effect and results in a localized mechanical strain in the sensor's waveguide. When the interrogation pulse ends, the strain is suddenly released, sending a rotational sonic strain pulse down the waveguide. The measurement cycle ends when the sonic strain pulse arrives at the end of the waveguide and is detected by the sensor's electronics. By accurately measuring the travel time of the sonic strain pulse the magnet's precise position is determined.

#### ASYNCHRONOUS MEASURING MODE

For the SSI sensor, the position data is always communicated to the controller or PLC using the Synchronous Serial Interface format. When the SSI sensor is operated as fast as possible, i.e. in Asynchronous Measuring Mode, the position data is updated and stored inside the sensor as quickly as the sensor's measurement cycle will allow. The minimum time for the measurement cycle is determined by the sensor's overall stroke length.

The controller's loop time will determine when the sensor's stored data is collected. For this mode the controller loop time is not synchronized with the sensor's measurement cycle time. However, if it is always slower than the sensor's cycle time then there will always be new position data available in the sensor's shift register, waiting to be clocked out over the SSI interface.

As shown in 'Figure 4', although the sensor is updating the position data as fast as possible, the actual data values collected by the controller can have varying delay times. This is shown as the delays from when the magnet's position was captured, (at the instant the interrogation pulse had started the relevant measurement cycle), to when the data is delivered at the end of the controller loop cycle.

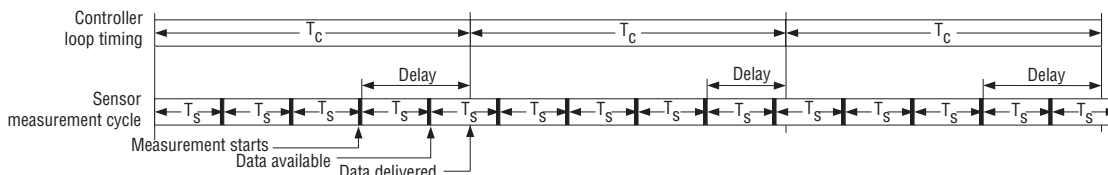
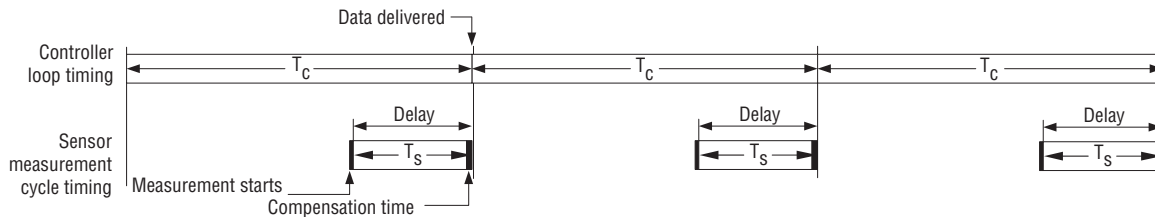

Figure 4. Asynchronous measuring mode, controller loop timing

### SYNCHRONOUS MEASURING MODE ('SYNC 1' OPTION)

Using the Synchronous Measuring Mode, the Temposonics SSI sensor has timing capabilities to optimize the communication link to the controller. Many motion control applications require velocity and/or acceleration be calculated, and therefore, must rely on position data having minimal delay, and minimal timing variability. With the Synchronous Measuring Mode, MTS Sensors has developed a proprietary algorithm to not only guarantee true measurement synchronization but at the same time minimize any propagation delay relative to the controller loop rate.

First, the sensor quickly determines the controller's loop timing – typically after one stable cycle period. Once this is known, and determined to be repeatable to specified limits, the sensor knows exactly when data will be required. The sensor then determines when to start the next measurement cycle, delaying the interrogation pulse, so that the measurement cycle will complete just in time to deliver the freshest data possible when the controller makes the next request, (see 'Figure 5').



**Figure 5.** Synchronous measuring mode, Sync 1 option

This form of synchronization to the controller provides the high quality position data needed for complex motion control algorithms and for multiple axes machines requiring tight coordination. When developing applications that will use the Synchronous Measuring Mode, the designer must choose a controller or PLC input module that supports this mode.

## ADVANCED OUTPUT OPTIONS

The Temposonics SSI sensor has advanced output options that are helpful for maximizing system performance in demanding applications requiring very high accuracy and speed.

### ENHANCEMENTS FOR THE SYNCHRONOUS MEASURING MODE ('SYNC 2' & 'SYNC 3' OPTIONS)

The 'Sync 2' option provides a high speed update feature. When motion control applications require new position data faster than the sensor's measurement cycle time, the high speed update feature provides extrapolated data values, calculated on the fly. A prediction algorithm generates usable position data for delivery to the controller whenever the sensor has not yet completed the next measurement cycle. These extrapolated values are used by the controller as normally updated position data, allowing very fast controller loop times that are necessary for tight control of high speed applications.

The 'Sync 3' option provides an additional enhancement to the high speed update feature of Sync 2. For this mode the prediction algorithm is used for all of the sensor's position data to compensate for the inherent lag time due to the sensor's measurement cycle.

### LINEARITY CORRECTION OPTION (LCO)

The Linearity Correction Option (LCO) provides improved sensor output accuracy. For most stroke lengths linearity accuracy is improved up to a factor of 5 resulting in deviations from actual position of less than +/- 20 microns (0.0008 in.). For stroke lengths over 5000 mm (197 in.), the linearity accuracy is improved up to a factor of 10. Selecting the sensor style and magnet is important (both must be matched together). Contact the factory for assistance when designing for the LCO in your application.

### ERROR DELAY (SKIP FILTER)

For applications having very high shock and vibration levels that exceed the sensor specification ratings the Error Delay (Skip Filter) can be used to prevent errors being produced on some types of controllers. During these very high shock events the sensor may fail to capture the magnet return signal, and if so, will normally output a zero position value. The Error Delay will instead repeat the last good output value. For long duration shock events the Error Delay will continue to repeat the good output value up to the number of times selected.

### NOISE REDUCTION FILTER

Complex systems can have various noise sources sometime significant enough to require filtering. If needed, a Simple Moving Average (SMA) filter function is available to reduce noise effects. The filter algorithm can be adjusted to include the last 2, 4, or 8 output values in the calculated average.

**PEAK REDUCTION FILTER**

A variation of the filter function is the Weighted Infinite Average (WIA) filter. If needed, this filter can provide a greater smoothing effect and has an adjustable weight parameter.

**TEMPERATURE MONITORING**

A temperature monitoring device is included inside the sensor electronics housing. Its output can be used to track the general operating conditions for the sensor and to monitor for over temperature. It cannot be used for calculating temperature compensation.

**Enhanced monitoring and diagnostics**

**SENSOR STATUS AND DIAGNOSTIC DISPLAY**

Diagnostic LEDs (green/red), located beside the connector or cable exit (see 'Figure 6'), provide basic visual monitoring for normal sensor operation and troubleshooting. Diagnostic display LEDs indicate four modes described in 'Table 1'.



**Figure 6.** R-Series sensor Integrated diagnostic LEDs

Green	Red	Operation status/mode
ON	OFF	Normal function (operation mode)
ON	ON	Magnet not detected or wrong quantity of magnets
ON	Flashing	Sensor not synchronous (For synchronous measurement mode only)
Flashing	ON	Programming mode

**Table 1.** Diagnostic display indicator modes

**Advanced communication and programmability**

**SENSOR FIELD PROGRAMMING**



Temposonics R-Series sensors with SSI are preconfigured at the factory by model number designation. In the event that sensor parameter changes are required in the field, the 'R-Series SSI PC Programming Kit, part no. 253310-1' (see 'Figure 7') can be used to easily program the sensor electronically without opening the sensor's housing.

**Figure 7.** R-Series SSI PC Programming Kit, Part no. 253310-1

**R-SERIES SSI PC PROGRAMMING KIT (PART NO.: 253310-1) INCLUDES THE FOLLOWING COMPONENTS:**

- Wall adapter style power supply (24 Vdc output).
- USB Serial converter box with USB cable to connect to PC
- Two connection cables:
  - Cable with connector if sensor is ordered with the D70 integral connector option.
  - Cable with quick connects if sensor is ordered with the integral cable option.
- R-Series SSI PC Setup software, on CD-ROM (for Windows XP or higher)

**FIELD PROGRAMMABLE PARAMETERS:**

- Data length
- Data format
- Resolution
- Measuring direction
- Synchronous / asynchronous measurement
- Measurement filter

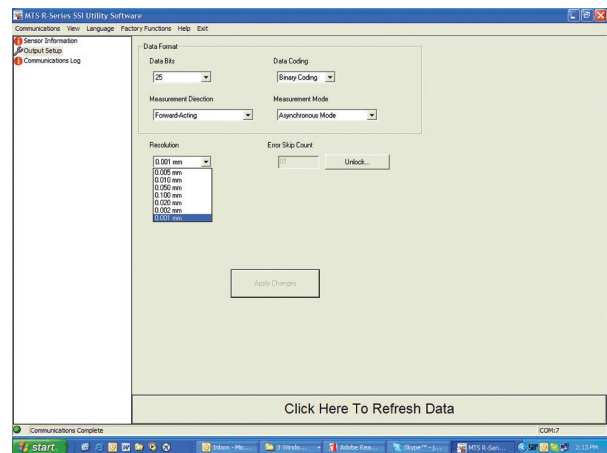

**Figure 8.** R-Series SSI PC Setup software interface

The Utility software included in the R-Series SSI PC Setup software provides a user-friendly interface (see 'Figure 8').

The setup software allows the following set of parameters to be field programmed.

**Model RP profile-style sensor dimension references**

**MODEL RP, PROFILE-STYLE SENSOR WITH CAPTIVE-SLIDING MAGNET**

Drawing is for reference only, contact applications engineering for tolerance specific information.

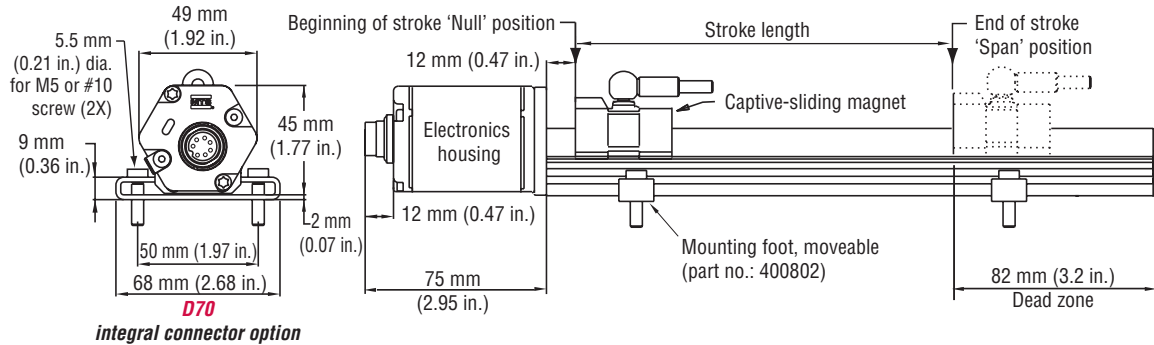

Figure 9. R-Series Model RP Profile-style sensor dimension reference (Shown with **D70** Integral connector option)

**MODEL RP, PROFILE-STYLE SENSOR WITH OPEN-RING MAGNET**

Drawing is for reference only, contact applications engineering for tolerance specific information.

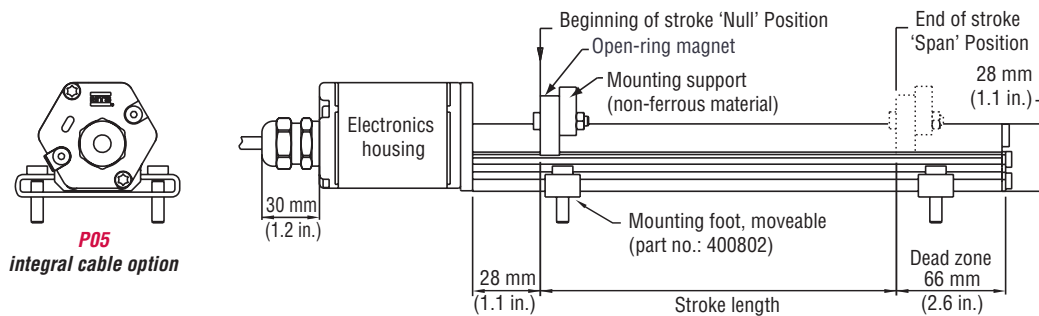

Figure 10. R-Series Model RP Profile-style sensor dimension reference (Shown with **P05** Integral cable option)

**Standard magnet selections (Model RP)**

**SELECTION OF POSITION MAGNETS (ONE MAGNET INCLUDED WITH MODEL RP SENSOR)**

A choice of two magnet mounting configurations are available with the profile-style sensor; A 'captive-sliding' magnet, *Styles S or V* or an 'open-ring' magnet, *Style M*. Captive-sliding magnets utilize slide bearings of special material that reduce friction, and if required, help mitigate dirt build up. The slide bearings are designed to operate dry, requiring no external lubrication or maintenance.

The *Style M* 'open-ring' magnet mounts on the moving machine part and travels just above the sensor's profile extrusion. The open-ring magnet requires a minimum distance away from ferrous metals to allow proper sensor output. It must be mounted using non-ferrous screws and a non-ferrous support bracket, or utilize a non-ferrous spacer of at least 5 mm (0.2 in.) thickness.

**POSITION MAGNET SELECTIONS** (Drawing dimensions are for reference only)

Magnet dimensions	Mounted magnet dimensions	Description	Part number
		<b>Captive-sliding magnet, Style S</b> For Model RP profile-style sensor	252182
		<b>Captive-sliding magnet, Style V</b> For Model RP profile-style sensor	252184

**PRODUCT DATA SHEET**

**R-Series Model RP Profile-Style Sensor  
Magnet Selections and Sensor Mounting**

Magnet dimensions	Mounted magnet dimensions	Description	Part number
<p>2 Holes Each 4 mm (0.17 in.) dia. on 24 mm (0.94 in.) dia.</p> <p>60°</p> <p>14 mm (0.55 in.)</p> <p>25 mm (0.97 in.)</p> <p>21 mm (0.81 in.)</p>	<p>Non-ferrous mounting support and screws</p> <p>21 mm (0.81 in.)</p> <p>Max gap 3 mm ± 1 mm (0.12 in. ± 0.04 in.)</p> <p>29 mm (1.14 in.)</p> <p>Open-ring magnet Style 'M'</p>	<p><b>Open-ring magnet, Style M</b></p> <p><b>I.D.:</b> 13.5 mm (0.53 in.) <b>O.D.:</b> 33 mm (1.3 in.) <b>Thickness:</b> 8 mm (0.31 in.) <b>Operating temperature:</b> - 40 °C to 100 °C</p>	251416-2

**Model RP Sensor mounting**

**MODEL RP PROFILE-STYLE SENSOR MOUNTING flexible installation in any position!**

Temposonics Model RP profile-style sensors offer two basic mounting methods; side grooves for use with mounting feet or a bottom groove that accepts special T-Slot nuts. Both the mounting feet and T-Slot nuts can be positioned along the sensor extrusion to best secure the sensor for each particular application.

**Notes:**

1. Model RP sensors include two mounting feet (part no. 400802) for sensors stroke lengths up to 1250 mm (50 in.)
2. One additional mounting foot is included for stroke lengths over 1250 mm (50 in.) and for each additional 500 mm (20 in.), thereafter.
3. MTS recommends using 10-32 cap screws (*customer supplied*) at a maximum torque of 44 in. lbs. when fastening mounting feet.

Profile-Style sensor mounting and installation reference	Mounting method	Part number
<p>4 Holes 5.3 mm (0.21 in.) dia.</p> <p>28 mm (1.1 in.)</p> <p>9 mm (0.36 in.)</p> <p>2 mm (0.08 in.)</p> <p>50 mm (1.97 in.)</p> <p>68 mm (2.68 in.)</p> <p>(Width = 14.5 mm (0.57 in.))</p>	<p><b>Mounting feet, standard (304 SS)</b> Profile-style sensor mounting for sensor model RP</p>	400802
<p>5 mm (0.196 in.) I.D.</p> <p>28 mm (1.1 in.)</p> <p>9 mm (0.36 in.)</p> <p>2 mm (0.08 in.)</p> <p>50 mm (1.97 in.)</p> <p>68 mm (2.68 in.)</p> <p>(Width = 14.5 mm (0.57 in.))</p>	<p><b>Mounting feet, Insulated (304 SS)</b> Profile-style sensor mounting for sensor model RP. Nylon washers and cloth tape on the bottom provide electrical isolation.</p>	252004
<p>10 - 32 Cap screws Recommended (Customer supplied)</p> <p>Mounting foot and screws</p>	<p><b>Mounting feet and screws</b> Profile-style sensor foot installation</p>	See Mounting Feet part numbers: 400802 and 252004
<p>T-Slot nut, M5 thread Detail</p> <p>5 mm (0.20 in.)</p> <p>M5 Threaded stud and nut</p>	<p><b>T-Slot nut</b> Nut for mounting model RP sensor M5 thread (optional, ordered separately)</p>	401602

Sold & Serviced By:



Toll Free Phone (877) SERV098  
Toll Free Fax (877) SERV099  
www.electromate.com  
sales@electromate.com

Dimension References

Model RH rod-style sensor dimension references

The Temposonics R-Series rod-style sensor (Model RH) offers modular construction, flexible mounting configurations, and easy installation. The Model RH sensor is designed for mounting in applications where high pressure conditions exist, (5000 psi continuous, 10,000 psi spike), such as inside hydraulic cylinders. The Model RH sensor (see Figure 9) may also be mounted externally in many applications.

Stroke-dependent Dead Zones:	
Stroke length:	Dead zone:
25 mm (1 in.) - 5000 mm (197 in.)	63.5 mm (2.5 in.)
5005 mm (197.1 in.) - 7620 mm (300 in.)	66 mm (2.6 in.)

MODEL RH, ROD-STYLE SENSOR WITH RING MAGNET (MAGNET ORDERED SEPARATELY)

Drawing is for reference only, contact applications engineering for tolerance specific information.

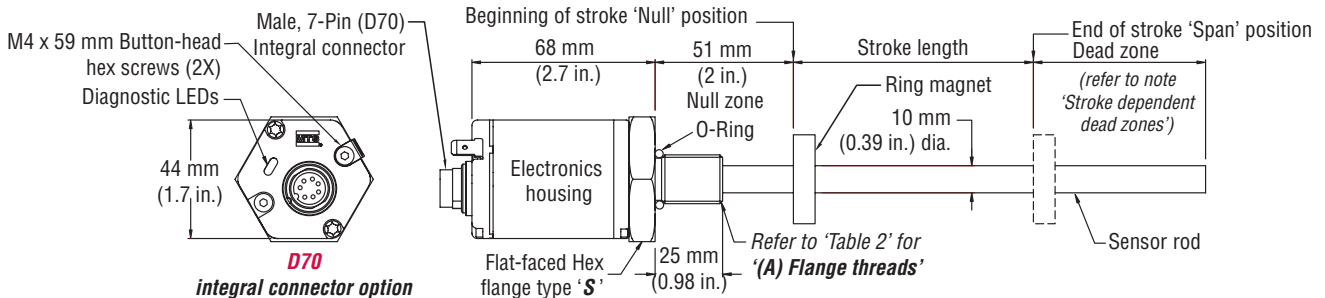

Figure 11. Model RP Profile-style sensor dimension reference (Shown with D70 Integral connector option)

MODEL RH, ROD-STYLE SENSOR WITH 7-PIN MATING CONNECTOR (MAGNET ORDERED SEPARATELY)

Drawing is for reference only, contact applications engineering for tolerance specific information.

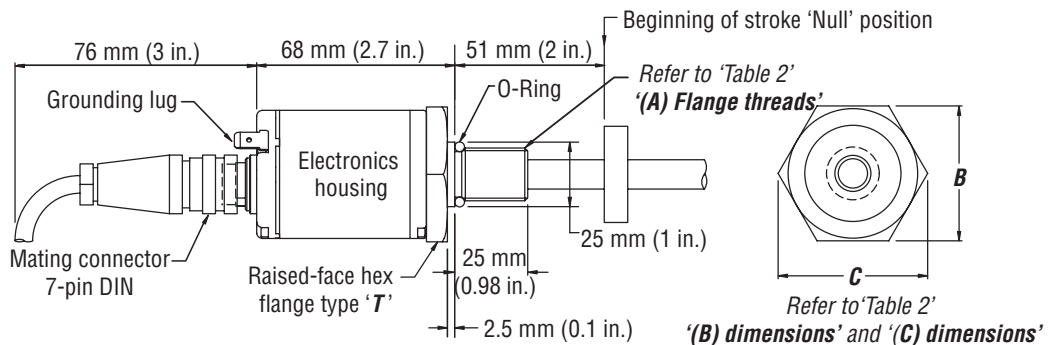

Figure 12. Model RH Rod-style sensor dimension reference (Shown with mating cable connector)

HOUSING STYLE FLANGE TYPE	DESCRIPTION	(A) FLANGE THREADS	(B) DIMENSIONS	(C) DIMENSIONS
T	US customary threads with raised-face flange	3/4" - 16 UNF-3A	1.75 in.	2 in.
S	US customary threads with flat-faced flange	3/4" - 16 UNF-3A	1.75 in.	2 in.
M	Metric threads with flat-faced Flange	M18 x 1.5	46 mm	53 mm

Table 2. Model RH Rod-style sensor housing style and flange type references









Standard magnet options (Model RH)

Magnets must be ordered separately with Model RH position sensors. The standard ring magnet (part number 201542-2) is suitable for most applications.

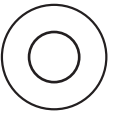
POSITION MAGNET SELECTIONS (Magnet must be ordered separately)

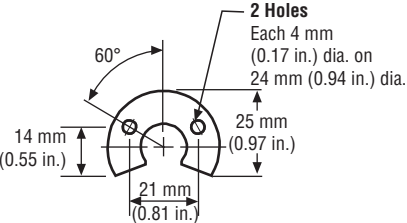
(Drawing dimensions are for reference only)

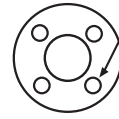
Magnet	Magnet dimensions	Description	Part number
	 <p><b>4 Holes</b> Each 4.3 mm (0.17 in.) dia. 90° apart on 24 mm (0.94 in.) dia.</p>	<b>Standard ring magnet</b> I.D.: 13.5 mm (0.53 in.) O.D.: 33 mm (1.3 in.) Thickness: 8 mm (0.3 in.) Operating temperature: - 40 °C to 100 °C	201542-2
		<b>Ring magnet</b> I.D.: 13.5 mm (0.53 in.) O.D.: 25.4 mm (1 in.) Thickness: 8 mm (0.3 in.) Operating temperature: - 40 °C to 100 °C	400533
	 <p><b>2 Holes</b> Each 4 mm (0.17 in.) dia. on 24 mm (0.94 in.) dia. 60° 14 mm (0.55 in.) 25 mm (0.97 in.) 21 mm (0.81 in.)</p>	<b>Open-ring magnet, Style M</b> I.D.: 13.5 mm (0.53 in.) O.D.: 33 mm (1.3 in.) Thickness: 8 mm (0.3 in.) Operating temperature: - 40 °C to 100 °C	251416-2
	 <p><b>4 Holes</b> Each 4.3 mm (0.17 in.) dia. 90° apart on 24 mm (0.94 in.) dia.</p>	<b>Magnet spacer</b> (Non-ferrous, use with ring magnet Part number: 201542-2) I.D.: 14 mm (0.56 in.) O.D.: 32 mm (1.25 in.) Thickness: 3.2 mm (0.125 in.)	400633

MAGNET FLOAT SELECTION

(Drawing dimensions are for reference only)

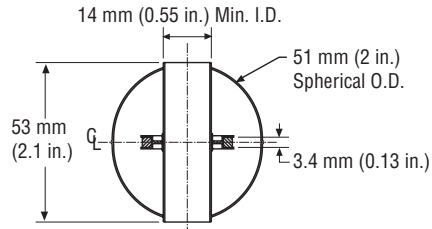
	 <p>14 mm (0.55 in.) Min. I.D. 51 mm (2 in.) Spherical O.D. 53 mm (2.1 in.) 3.4 mm (0.13 in.)</p>	<b>Magnet float</b> <b>(Level sensing applications)</b> Specific gravity: 0.70 maximum Pressure: 870 psi maximum  (This float is used with the Model RH rod-style sensors for hydraulic fluid or fresh water applications only)	251447
---	--	--	--------

## Model RH Rod-Style Sensor Mounting

### MODEL RH SENSOR MOUNTING

The position magnet requires minimum distances away from ferrous metals to allow proper sensor output. The minimum distance from the front of the magnet to the cylinder end cap is 15 mm (0.6 in.).

The minimum distance from the back of the magnet to the piston head is 3.2 mm (0.125 in.). The non-ferrous spacer (part no. 400633), provides this minimum distance when used along with the standard ring magnet (part no.: 201542-2).

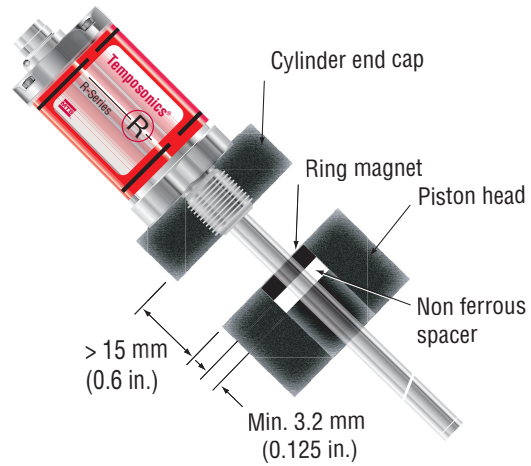

Figure 13. Model RH rod-style mounting

## Cylinder installation

When used for direct-stroke measurement in fluid cylinders, the sensor's high pressure, stainless steel rod installs into a bore in the piston head/rod assembly as illustrated. This method guarantees a long-life and trouble-free operation.

The sensor cartridge can be removed from the flange and rod housing while still installed in the cylinder. This procedure allows quick and easy sensor cartridge replacement, without the loss of hydraulic pressure.

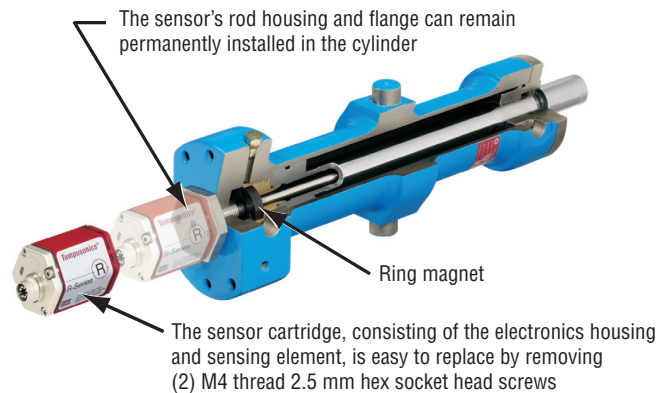

Figure 14. Fluid cylinder installation

Connections and wiring

STANDARD MALE 7-PIN DIN (D70) INTEGRAL CONNECTOR WIRING



Male, 7-pin (D70) integral connector (pin-out as viewed from the end of the sensor)

Pin no.	Ext. cable	Function / SSI outputs
1	Gray	Data (-)
2	Pink	Data (+)
3	Yellow	Clock (+)
4	Green	Clock (-)
5	Brown	+24 Vdc (-15/+20%)
6	White	DC ground (for supply)
7	N.C.	N/A

OPTIONAL, MALE 10-PIN (MS) STYLE CONNECTOR WIRING

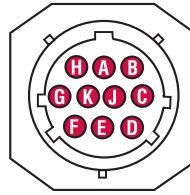

Male, 10-pin (MS) integral connector (pin-out as viewed from the end of the sensor)



Pin no.	Ext. cable	Function / SSI outputs
A	White	DC Ground
B	-	No connection
C	Gray	Data (-)
D	Pink	Data (+)
E	Red	+24 Vdc (-15 / +20%)
F	-	No connection
G	Yellow	Clock (+)
H	Green	Clock (-)
I	-	No connection
J	-	No connection
K	-	No connection

Notes:

1. Sensor diagnostics LED's are not available with the MS connector option.
2. MS style cable connector, part no.: 370013, (field installed) mates with the integral MS connector.

CABLE CONNECTOR OPTIONS (FIELD INSTALLABLE) 7-PIN DIN (D7) FEMALE

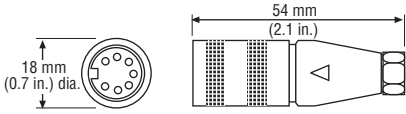
(Drawing dimensions are for reference only)

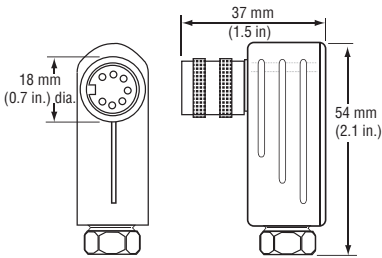
Connector	Connector dimensions	Description	Part number
		<b>Cable Connector, Female, Straight Exit (Field installable)</b> 7-Pin DIN (D70) Mates with standard male (M16) integral connector	560701
		<b>Cable Connector, Female, 90° Exit (Field installable)</b> 7-Pin DIN (D70) Mates with standard male (M16) integral connector	560779

**EXTENSION CABLE WITH CONNECTORS FOR D7 (D70), CONNECTION TYPES**

Extension cable and connector assemblies	Description	Connection Type
	<b>Female Connector, Straight Exit and Orange Polyurethane Jacket Cable with High-Performance Shielding</b> (Assembly Includes D7 Connector, Part No.: 560701 and Cable, part no.: 530029)	<b>D7</b>
	<b>Female Connector, 90° Exit and Orange Polyurethane Jacket Cable with High-Performance Shielding</b> (Assembly Includes D7 Connector, Part No.: 560779 and Cable, part no.: 530029)	<b>DR</b>
	<b>Female Connector, Straight Exit and Standard PVC Jacket Cable</b> (Assembly Includes D7 Connector, Part No.: 560701 and Cable, part no.: 530026)	<b>DS</b>
	<b>Female Connector, 90° Exit and Standard PVC Jacket Cable</b> (Assembly Includes D7 Connector, Part No.: 560779 and Cable, part no.: 530026)	<b>DT</b>
	<b>Female Connector, Straight Exit and Black Polyurethane Jacket Cable (for higher resistance to moisture, oil and cold temperatures)</b> (Assembly Includes D7 Connector, Part No.: 560701 and Cable, part no.: 530045)	<b>DU</b>
	<b>Female Connector, 90° Exit and Black Polyurethane Jacket Cable (for higher resistance to moisture, oil and cold temperatures)</b> (Assembly Includes D7 Connector, Part No.: 560779 and Cable, part no.: 530045)	<b>DV</b>

**Ordering Information - Extension cable and connector assembly for connection type D7 (D70)**

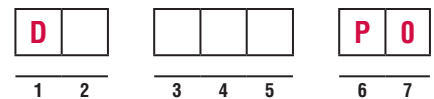

**SENSOR CONNECTION TYPES**

- D7** = Female connector, straight exit (part no. 560701), and orange polyurethane jacket cable (part no.: 530029)
- DR** = Female connector, 90° exit (part no. 560779), and orange polyurethane jacket cable (part no.: 530029)
- DS** = Female connector, straight exit (part no. 560701), and PVC jacket cable (part no. 530026)
- DT** = Female connector, 90° exit (part no. 560779), and PVC jacket cable (part no.: 530026)
- DU** = Female connector, straight exit (part no. 560701), and black polyurethane jacket cable (part no. : 530045)
- DV** = Female connector, 90° exit (part no. 560779), and black polyurethane jacket cable (part no.: 530045)

**CABLE LENGTHS**

- 005** = 5 ft
- 015** = 15 ft
- 025** = 25 ft
- 050** = 50 ft
- 100** = 100 ft

**For custom length cables over 100 ft**

--- = Cable length (maximum cable length is dependent on baud rate).

**R-Series SSI extension cable length limitations**

Baud rate	Maximum cable or bus length	
1.0 MBd	10 ft.	3 m
400 kBd	160 ft.	50 m
300 kBd	320 ft.	100 m
200 kBd	650 ft.	200 m
100 kBd	1300 ft.	400 m

**CABLE TERMINATION**

**PO** = Pigtail cable without connector





Ordering information

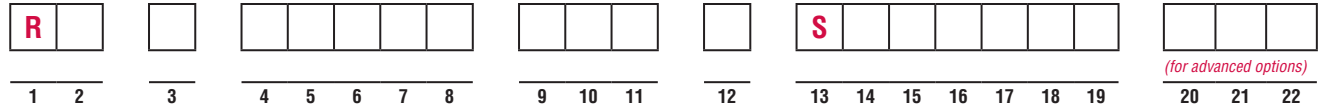

OUTPUT (13 - 22)

S + the 6 or 9 digit Output code

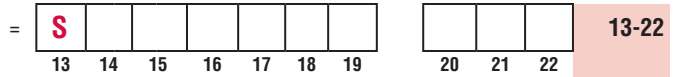

[14] Data length

- 1 = 25 bits
- 2 = 24 bits
- 3 = 26 bits

[15] Output Format

- B = Binary
- G = Gray code

[16] Resolution

- 1 = 0.005 mm
- 2 = 0.01 mm
- 3 = 0.05 mm
- 4 = 0.1 mm
- 5 = 0.02 mm
- 6 = 0.002 mm
- 8 = 0.001 mm
- 9 = 0.0005 mm

[17] Filtering Performance

- 1 = Standard, no filter
- A = No filter + error delay (4 cycles)
- C = No filter + error delay (8 cycles)
- D = No filter + error delay (10 cycles)
- G = Noise reduction filter (8 values) + error delay (10 cycles)
- K = Peak reduction filter (8 values)
- N = Peak reduction filter (8 values) + error delay (10 cycles)

[18] [19] Signal Options (scale orientation)

- 00 = Measuring direction forward, async
- 01 = Measuring direction reverse, async
- 02 = Measuring direction forward, sync1
- 05 = Measuring direction forward, bit-25 = Alarm, bit-26 = Parity even, (select data length 24 bits)
- 16 = Measuring direction forward, LCO
- 99 = Advanced output options (Enter 99 and an additional 3 character suffix only if one or more 'Advanced Output Options' are required).

Advanced Output Options

[20] Measurement Contents

- 1 = Position
- 2 = Position difference between 2 magnets
- 3 = Velocity
- 4 = Position + temperature
- 5 = Position difference between 2 magnets + temperature
- 6 = Velocity + temperature

[21] Direction and Sync Mode

- 1 = Forward async
- 2 = Forward sync1
- 3 = Forward sync2
- 4 = Forward sync3
- 5 = Reverse async
- 6 = Reverse sync1
- 7 = Reverse sync2
- 8 = Reverse sync3

[22] Linearity Correction Option (LCO) and Communication Diagnostics

- 0 = No further option
- 1 = LCO
- 2 = Additional alarm bit + even parity bit
- 4 = Additional alarm bit + even parity bit + LCO