

Temposonics®

Magnetostrictive, Absolute, Non-contact
Linear-Position Sensors



MH-Series Mobile Hydraulic in-Cylinder Sensor

Model MT, Redundant - Analog Output

Data Sheet

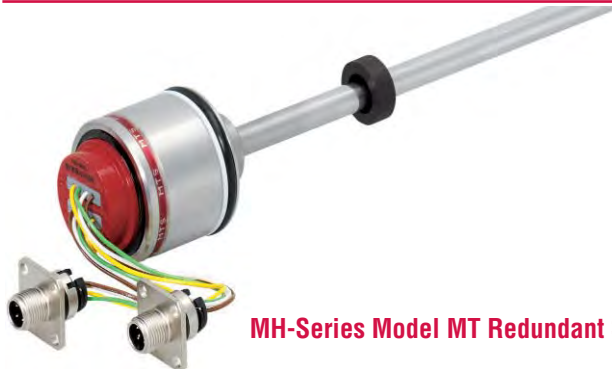

MH-Series Model MT Redundant Sensor



Cylinder Application Example

FEATURES

- Linear, Absolute Position Sensors
- Non-Contact Sensing Technology
- Superior Accuracy, $< \pm 0.04\%$ F.S.
- Repeatability, $< \pm 0.005\%$ F.S.
- Compact Design for Embedded Cylinder Applications
- Dual, Electrically Redundant Analog Outputs:
Current and Voltage
- Stroke length: 50 mm (2 in.) to 1500 mm (59 in.)
- Voltage input: 12/24 Vdc
- Shock Rating: 100 g (single hit) / IEC 68-2-27
- Vibration Rating 15 g / 10-2000 Hz/IEC 68-2-6
- 100 V/m EMI Immunity

BENEFITS

- Rugged Industrial Sensor
- Dual, Electrically Redundant Analog Outputs

APPLICATIONS

- Continuous Operation In Harsh Mobile Conditions
- High Pressure Conditions
- For Welded and Tie-rod Cylinder Applications

TYPICAL INDUSTRIES

- Construction
- Agriculture
- Off-highway Machinery

Product overview

The MH-Series Model MT sensor is designed with the “mobile” world in mind and applies specifically to applications that require redundancy. The Model MT sensor is validated in the field by customers worldwide. Performance is second-to- none; high accuracy, 100 V/m EMI, position output. Ruggedness is “designed in”; 100 g shock and 15 g vibration rating. The model MT redundant sensor can be fully sealed and embedded in a cylinder to ensure a long operating life.

Sold & Serviced By:



Toll Free Phone (877) SERV098

Toll Free Fax (877) SERV099

www.electromate.com

sales@electromate.com

Product Specifications and Output Options

Product specifications

Parameters	Specifications
OUTPUT	
Measured variable:	Linear Position measurement
Resolution:	Range: Resolution: 50 to 500 mm 0.1 mm 150 mm 0.18 mm 1,000 mm 0.24 mm 1,250 mm 0.3 mm 1,500 mm 0.38 mm
Outputs:	Voltage: Current: 0.25 to +1.75 Vdc 4 to 20 mA 0.5 to 4.5 Vdc Reverse: Reverse: 20 to 4 mA 4.75 to 0.25 Vdc ≤ 250Ω at 12/24 Vdc 4.5 to 0.5 Vdc power supply > 10kΩ at 12/24 Vdc power supply
Stroke length:	50 mm to 1500 mm (2 in. to 59 in.) Measured in 5 mm (0.20 in.) increments
Linearity uncorrected:	< ± 0.04% full stroke (minimum ± 0.100 mm 0.003 in.)
Repeatability:	< ± 0.005% of full stroke
Hysteresis:	± 0.1 mm (0.003 in.)
Outputs:	Analog, dual electrically redundant: ‡ Voltage: 0.25 to 4.75 Vdc , 0.5 to 4.5 Vdc (reverse: 4.75 to 0.25 Vdc, 4.5 to 0.5 Vdc) ‡ Current: 4 to 20 mA (reverse: 20 to 4 mA)
Operating voltage:	12/24 Vdc (8-32 Vdc)
Power consumption:	1 W maximum (per sensor)
ELECTRONICS	
Electrical isolation:	500 Vdc (DC ground to machine ground)
Polarity protection:	Up to -36 Vdc
Overvoltage protection:	Up to 36 Vdc

Parameters	Specifications
ENVIRONMENTAL	
Operating conditions:	Operating: -40 °C (-40 °F) to +105 °C (221 °F) Storage: -30 °C (-22 °F) to +105 °C (221 °F) 90% relative humidity, no condensation
EMC test:	100 V/m: ISO 11452-5 ISO 14982 to Agriculture and forest machinery
Shock rating:	100 g (single hit)/IEC standard 68-2-27 (survivability)
Vibration rating:	15 g / 10 to 2000 Hz /IEC standard 68-2-6
WIRING	
Connection type:	One 4-pin and one 5-pin with the M12 x 1 connector and flange (provides IP69K environmental protection when installed in a cylinder).
ROD STYLE SENSOR (MODEL MT)	
Material:	Sensor rod: Stainless steel 1.4306 / AISI 304L Housing: Stainless steel 1.4305 / AISI 303 Mechanical assembly: Flange housing 48 mm (1.89 in.) dia., O-ring 40.87 x 3.53 mm NBR 80, backup ring 42.6 x 48 x 1.4 PTFE
Sealing:	IP67 (IP69k when installed inside a cylinder with M12 x 1 in. connection type)
Pressure rating:	Sensor rod, 10 mm (0.39 in.): Operating, 350 bar (5076 psi) Peak, 530 bar (7687 psi)
Magnet type:	Ring magnet,
‡ Output range is factory programmable through entire stroke and is fully reversible.	

Output options

The MH-Series Model MT position analog sensor provides two, analog, electrically redundant outputs:

- Voltage; 0.25 to 4.75 Vdc, 0.5 to 4.50 Vdc (reverse acting: 4.75 to 0.25 Vdc, 4.5 to 0.5 Vdc)
- Current; 4 to 20 mA (reverse acting: 20 to 4 mA)

Sold & Serviced By:

 **ELECTROMATE**

Toll Free Phone (877) SERV098

Toll Free Fax (877) SERV099

www.electromate.com

sales@electromate.com

Model MT redundant sensor dimension references

Model MT, rod-style Redundant Sensor Drawing is for reference only, contact applications engineering for tolerance specific information.

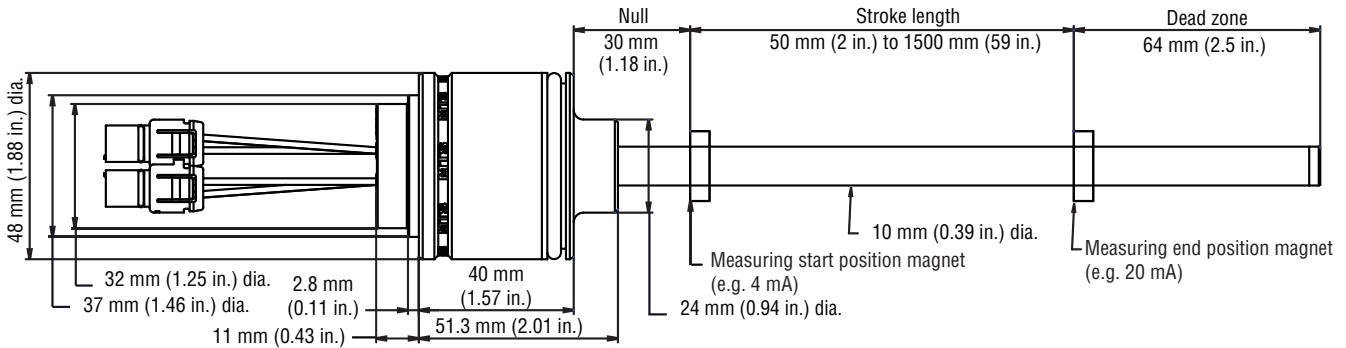

Figure 1. MH-Series Model MT rod-style sensor dimension reference

Standard magnet selections (Model MT)

SELECTION OF POSITION MAGNETS (MAGNET AND MAGNET SPACER MUST BE ORDERED SEPARATELY)

A choice of three magnets are available with the Model MT rod-style sensor. Magnets must be ordered separately with Model MT position sensors. The standard ring magnet (part number 201542-2) is suitable for most applications.

STANDARD RING MAGNET Part number 201542-2



Material: Ferrite PA
I.D.: 13.5 mm (0.53 in.)
O.D.: 33 mm (1.3 in.)
Thickness: 8 mm (0.3 in.)
Operating temperature:
 - 40 °C (-40 °F) to
 - 105 °C to (221 °F)

MAGNET SPACER Part number 400633

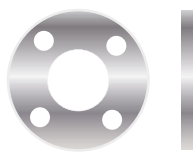

Material: Non-ferrous, used with
 ring magnet (part no.: 201542-2)
I.D.: 14 mm (0.56 in.)
O.D.: 32 mm (1.25 in.)
Thickness: 3.2 mm (0.125 in.)

RING MAGNET Part number 400533



Material: Ferrite PA
I.D.: 13.5 mm (0.53 in.)
O.D.: 25.4 mm (1 in.)
Thickness: 8 mm (0.3 in.)
Operating temperature:
 - 40 °C (-40 °F) to
 - 105 °C to (221 °F)

RING MAGNET Part number 401032



Material: Ferrite PA
I.D.: 13.5 mm (0.53 in.)
O.D.: 17 mm (0.68 in.)
Thickness: 8 mm (0.31 in.)
Operating temperature:
 - 40 °C (-40 °F) to
 - 105 °C to (221 °F)

Sold & Serviced By:

ELECTROMATE

Toll Free Phone (877) SERV098

Toll Free Fax (877) SERV099

www.electromate.com

sales@electromate.com

Model MT Rod-Style Sensor

Installation

Model MT redundant sensor installation references

The robust Temposonics Model MT Redundant sensor's new stainless-steel position sensor is designed for direct stroke measurement in mobile hydraulic cylinders. The Temposonics Model MT Redundant sensor can be installed from the head side or the rod side of the cylinder depending on the cylinder design.

Installation Notes:

1. Use a non-ferrous circlip to fix the magnet.
2. The piston rod bore is dependent on hydraulic pressure and piston velocity. Minimum drilling for a (10 mm rod) should be 13.5 mm.

Model MT, rod-style redundant sensor mechanical installation Drawing is for reference only, contact applications engineering for tolerance specific information.

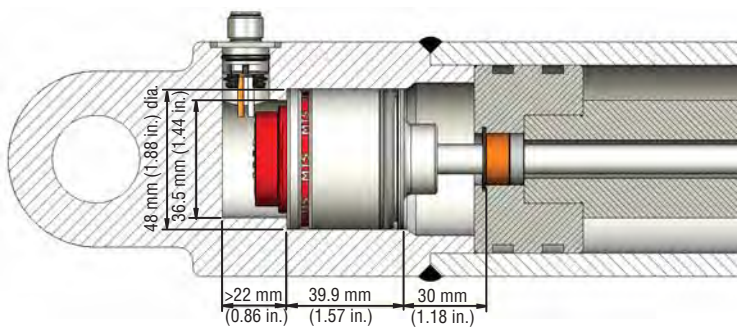

Figure 2. MH-Series Model MT rod-style sensor mechanical installation example

Model MT, rod-style redundant sensor installation Drawings are for reference only, contact applications engineering for tolerance specific information.

Installation methods are possible in magnetic and non-magnetic applications (shown in Figures 3 and 4) and are entirely dependent on the cylinder design. While the most common method of installation is from the rod side of the cylinder, installation from the head side of the cylinder is also possible. In both installation methods, the sensor seals the cylinder by using an O-Ring and backup ring which is installed on the sensor housing.

Magnetic material installation reference

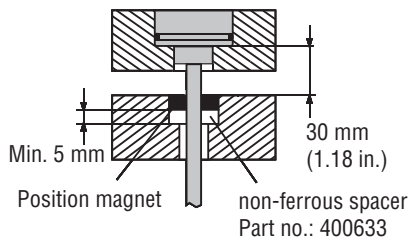

Figure 3. Model MT installation in magnetic material using magnet spacer, part number 400633

Non-magnetic material installation reference

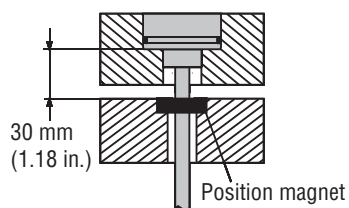
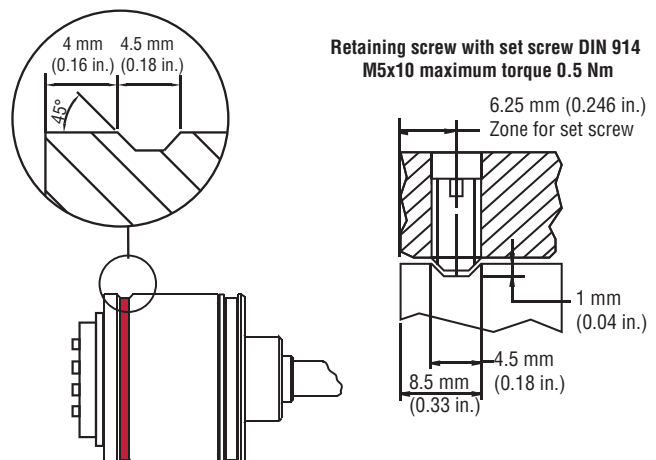

Figure 4. Model MT installation in non-magnetic material (without magnet spacer, part number 400633)

Set screw detail



Connections and wiring

CONNECTION TYPE

The Temposonics® M12 connector system (shown in *Figures 7, 8, 9 and 10*), meets the most stringent protection requirements important for the difficult environmental conditions of mobile hydraulics applications. Protection type IP69K makes the robust metal housing not only completely dust- and waterproof, even the harshest cleaning measures cannot damage the sensor.

Model MT, rod-style redundant Sensor connector and pin assignments *Drawings are for reference only, contact applications engineering for tolerance specific information.*

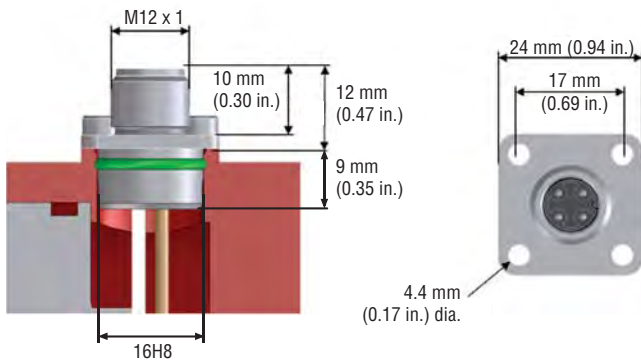
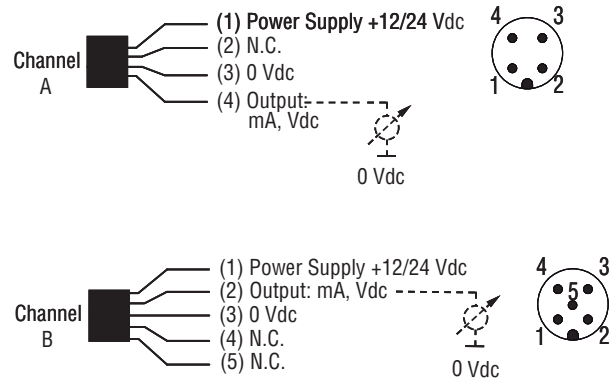

Figure 5. Model MT sensor connection dimensions



MOUNTING THE CONNECTOR SYSTEM TO THE CYLINDER

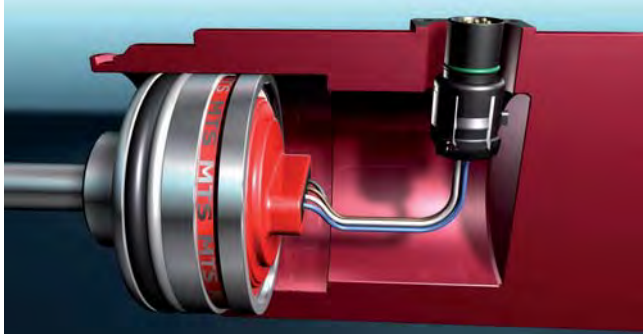

Figure 7. The MH sensor is delivered by MTS together with the new connector system: The connector insert carrier is already connected to the sensor electronics, i.e. no soldering, any color or connection mistake.



Figure 9. Four standard screws must be tightened to mount the connector flange on the cylinder.



Figure 8. The connector insert is taken out of the cylinder through a bore hole. The flange housing can be snapped into position easily from outside.



Figure 10 With a corresponding mating molded plug the connector system fulfills an ingress protection (IP) of 69K.

Sold & Serviced By:

ELECTROMATE

Toll Free Phone (877) SERV098

Toll Free Fax (877) SERV099

www.electromate.com

sales@electromate.com

Model MT Rod-Style Sensor

Ordering Information

MH-Series Model MT ordering information

Use the table below to configure your sensor part number.

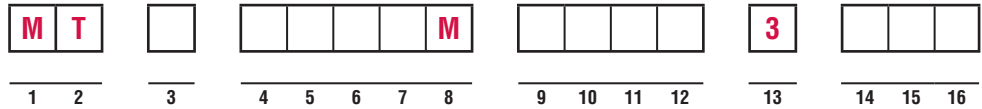

SENSOR MODEL _____ = **M T** 1-2

MT = Rod-style with pressure fit flange housing 48 mm (1.9 in.) dia.

SENSOR STYLES _____ = _____ 3

C = Rod-style 10 mm (0.39 in.) dia.

R = Rod-style 10 mm (0.39 in.) dia. with welded threaded end plug M4

STROKE LENGTH (ORDER LENGTH) _____ = _____ 4-8

----- **M** = Millimeters
50 to 1500 mm (2 in. to 59 in.) (in 5 mm increments)

CONNECTION TYPE _____ = _____ 9-12

N__R = Channel A: 4 single wires, M12 IP69K, 4 pin (pin assignment 2 x 1-3-4)

Channel B: 4 single wires, M12 IP69K, 5 pin (pin assignment 2 x 1-2-3)

N06R - 60 mm min. wire length

N25R - 250 mm max. wire length

INPUT VOLTAGE _____ = **1** 13

3 = +12/24 Vdc

OUTPUT _____ = _____ 14-16

CHANNEL A

V11 = 0.25 to 4.75 Vdc

V12 = 0.5 to 4.5 Vdc

V13 = 4.75 to 0.25 Vdc

V14 = 4.5 to 0.5 Vdc

V21 = 0.25 to 4.75 Vdc

V22 = 0.5 to 4.5 Vdc

A01 = 4 to 20 mA

A04 = 20 to 4 mA

A21 = 4 to 20 mA

CHANNEL B

0.25 to 4.75 Vdc

0.5 to 4.5 Vdc

4.75 to 0.25 Vdc

4.5 to 0.5 Vdc

4.75 to 0.25 Vdc

4.5 to 0.5 Vdc

4 to 20 mA

20 to 4 mA

20 to 4 mA

Sold & Serviced By:



Toll Free Phone (877) SERV098

Toll Free Fax (877) SERV099

www.electromate.com

sales@electromate.com

Magnet selections and optional test kit

Magnets and the MH-Series Analog/PWM tester must be ordered separately. Refer to the table below for ordering information.

Magnet selections	Part no.
Ring magnet, O.D. 17.4 mm	401032
Ring magnet, O.D. 25.4 mm	400533
Ring magnet, O.D. 33 mm	201542-2
Magnet spacer	400633

Optional accessory	Part no.
MH-Series Analog/PWM tester	280618
The MH-Series Tester includes:	
<ul style="list-style-type: none">• MH-Series analog / PWM Tester• 12 Vdc battery charger with adapter• (adapter main plug EU, adapter main plug UK)• Cable with M12 x 1 connector• Cable with pigtailed wires• Carrying case• CD-Rom with user's guide	



MH-Series Analog/PWM tester, part no.: 280618

Sold & Serviced By:

 **ELECTROMATE**

Toll Free Phone (877) SERV098

Toll Free Fax (877) SERV099

www.electromate.com

sales@electromate.com