

Note: See page 14 for a complete description of the above part number system.

Sold & Serviced By:  
  
 Toll Free Phone (877) SERV098  
 Toll Free Fax (877) SERV099  
[www.electromate.com](http://www.electromate.com)  
[sales@electromate.com](mailto:sales@electromate.com)

(E) - English Interface	(M) - Metric Interface
(LFT) - Left Facing Thread	(NPL) - Non Preloaded
(LH) - Left Hand	(PL) - Preloaded
(LT) - Low Thrust	(RFT) - Right Facing Thread
(HT) - High Thrust	(RH) - Right Hand

## Screw & Nut Specifications

Model Number	Nut Type	Diameter inches (mm)	Lead inches (mm)	Root Diameter inches (mm)	Ball Diameter inches (mm)	Number of Circuits	Static Load lbs (kgf)	Dynamic Load <sup>(1)</sup> lbs (kgf)
<b>GS062020</b> 0.625 inch dia. 0.200 inch lead	<b>Preloaded Ball (N3/N4)</b>	0.625 (15,87)	0.200 (5,08)	0.513 (13,03)	0.125 (3,17)	1	3,080 (1397)	987 (447)
<b>GS16M05M</b> 16 mm dia. 5 mm lead	<b>Preloaded Ball (N3/N4)</b>	0.629 (16,00)	0.196 (5,00)	0.513 (13,03)	0.125 (3,17)	1	3,080 (1397)	987 (447)
<b>GS16M16M</b> 16 mm dia. 16 mm lead	<b>Preloaded Ball (N3/N4)</b>	0.629 (16,00)	0.629 (16,00)	0.529 (13,44)	0.125 (3,17)	1	1,800 (816)	910 (412)

## Other Specifications

<b>Maximum Acceleration Rate</b>	Ball nut: 772 inches/sec <sup>2</sup> (19,6 m/sec <sup>2</sup> )
<b>Maximum Speed</b>	Ball nut: 3000 rpm
<b>Screw Material</b>	Right Hand Thread, Case Hardened Rc 58 Steel Ground Ball Screw
<b>Screw Extensions</b>	303 Woodruff Keyways on Extensions from Support Housings
<b>Screw Maximum Length</b> <sup>(2)</sup>	45.27 inches (1150 mm)
<b>Screw Weight</b>	0.87 lbs/ft (13,0 g/cm)
<b>Support Housings</b>	Steel with Black Oxide Finish, 45° Chamfer x .02 inch (0,50) all Straight Edges
<b>Support Housing Features</b>	Base or Face Mount with Integral Seals
<b>Nut Flanges</b>	Steel with Black Oxide Finish
<b>Nut Flange Features</b>	English or Metric Load Mounting Interface

### Footnotes:

- (1) Load based upon 1 million inches (25 Km) of travel life. See page 83 for further travel life ratings.  
 (2) Maximum stock length (not the maximum thread length with bearing housings). See page 82 for maximum thread lengths for each configuration.

## Screw Specifications

Model Number	Nut Type	Screw Efficiency %	Lead Error inch/ft (mm/300 mm)	Backlash inches (mm)	Unidirectional Repeatability inches (mm)	Bidirectional Repeatability inches (mm)
<b>GS062020</b> 0.625 inch dia. 0.200 inch lead & <b>GS16M05M</b> 16 mm dia. 5 mm lead & <b>GS16M16M</b> 16 mm dia. 16 mm lead	<i>Preloaded Ball (N3/N4)</i>	90	< 0.0005 (0,012)	0	+/- 0.0001 (0,0025)	+ 0.0001 to - 0.0001 (0,0025) (0,0025)

## Assembly Specifications

Model Number	Nut Type	Breakaway Torque oz-in (N-m)				
		Simple-Simple	Fixed(LT)-Simple	Fixed(HT)-Simple	Rigid-Simple	Rigid-Rigid
<b>GS062020</b> 0.625 inch dia. 0.200 inch lead	<i>Preloaded Ball (N3/N4)</i>	< 15 (0,11)	< 20 (0,14)	< 30 (0,21)	< 30 (0,21)	< 40 (0,28)
<b>GS16M05M</b> 16 mm dia. 5 mm lead	<i>Preloaded Ball (N3/N4)</i>	< 15 (0,11)	< 20 (0,14)	< 30 (0,21)	< 30 (0,21)	< 40 (0,28)
<b>GS16M16M</b> 16 mm dia. 16 mm lead	<i>Preloaded Ball (N3/N4)</i>	< 25 (0,18)	< 35 (0,24)	< 45 (0,32)	< 45 (0,32)	< 55 (0,39)

## Internal Order Code

Model Number	Internal Order Code & Support Configuration	Maximum Thread Length "L" inches (mm)	Model Number	Internal Order Code & Support Configuration	Maximum Thread Length "L" inches (mm)	Model Number	Internal Order Code & Support Configuration	Maximum Thread Length "L" inches (mm)
<b>GS062020</b> 0.625 inch dia. 0.200 inch lead & <b>GS16M05M</b> 16 mm dia. 5 mm lead & <b>GS16M16M</b> 16 mm dia. 16 mm lead	-1-S1	18.250 (463,6)	<b>GS062020</b> 0.625 inch dia. 0.200 inch lead	-2-S1	41.500 (1054,1)	<b>GS16M05M</b> 16 mm dia. 5 mm lead & <b>GS16M16M</b> 16 mm dia. 16 mm lead	-2-S1	37.500 (952,5)
	-1-S2	18.250 (463,6)		-2-S2	41.500 (1054,1)		-2-S2	37.500 (952,5)
	-1-S3	18.250 (463,6)		-2-S3	41.500 (1054,1)		-2-S3	37.500 (952,5)
	-1-S4	18.250 (463,6)		-2-S4	41.500 (1054,1)		-2-S4	37.500 (952,5)
	-1-S5	16.500 (419,1)		-2-S5	39.750 (1009,6)		-2-S5	35.800 (909,3)

## Support Housing Specifications

Support Housing Life millions of screw revolutions	Support Housing Thrust Load Capacity - (Axial)			
	Simple	Fixed (LT)	Fixed (HT)	Rigid
<b>Static</b>	1,370 (621)	1,725 (782)	3,105 (1408)	3,105 (1408)
<b>1</b>	1,370 (621)	1,725 (782)	2,875 (1304)	2,875 (1304)
<b>2</b>	1,215 (551)	1,530 (694)	2,195 (996)	2,195 (996)
<b>10</b>	710 (322)	895 (406)	1,295 (587)	1,295 (587)
<b>50</b>	410 (186)	525 (238)	790 (358)	790 (358)
<b>100</b>	330 (150)	415 (188)	630 (286)	630 (286)
<b>500</b>	195 (88)	240 (109)	365 (166)	365 (166)

Thrust force applied in either direction

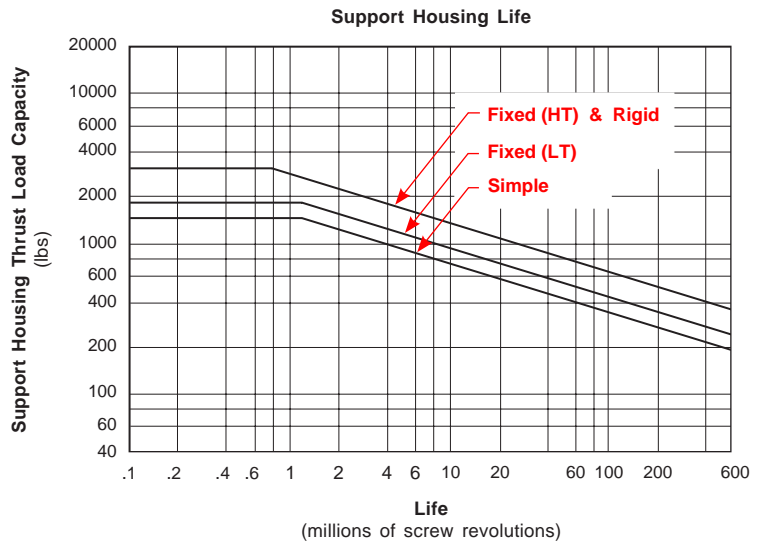
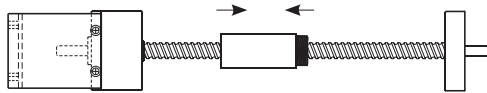

Note: Multiply screw revolutions by the screw lead in order to convert to inches (or mm) traveled by the nut.

## Available Configurations

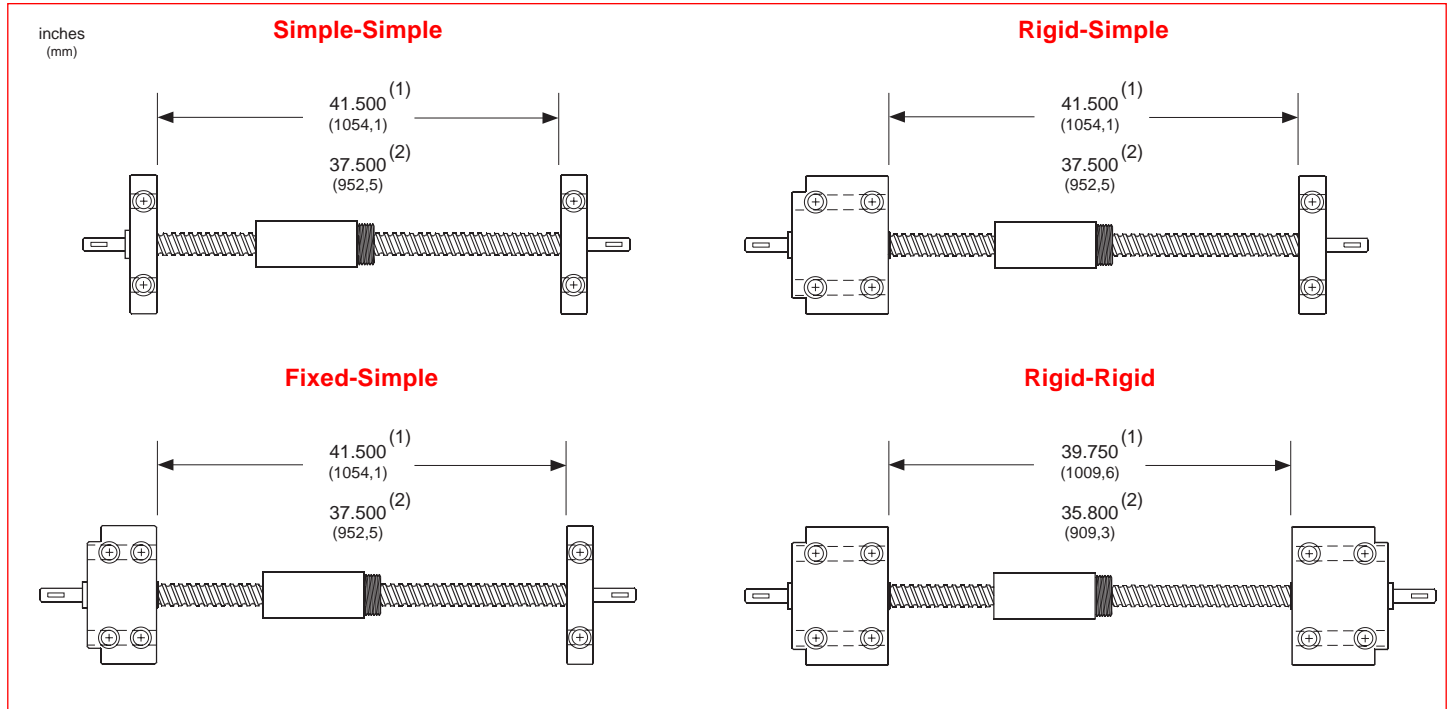

## Overall Length Diagram

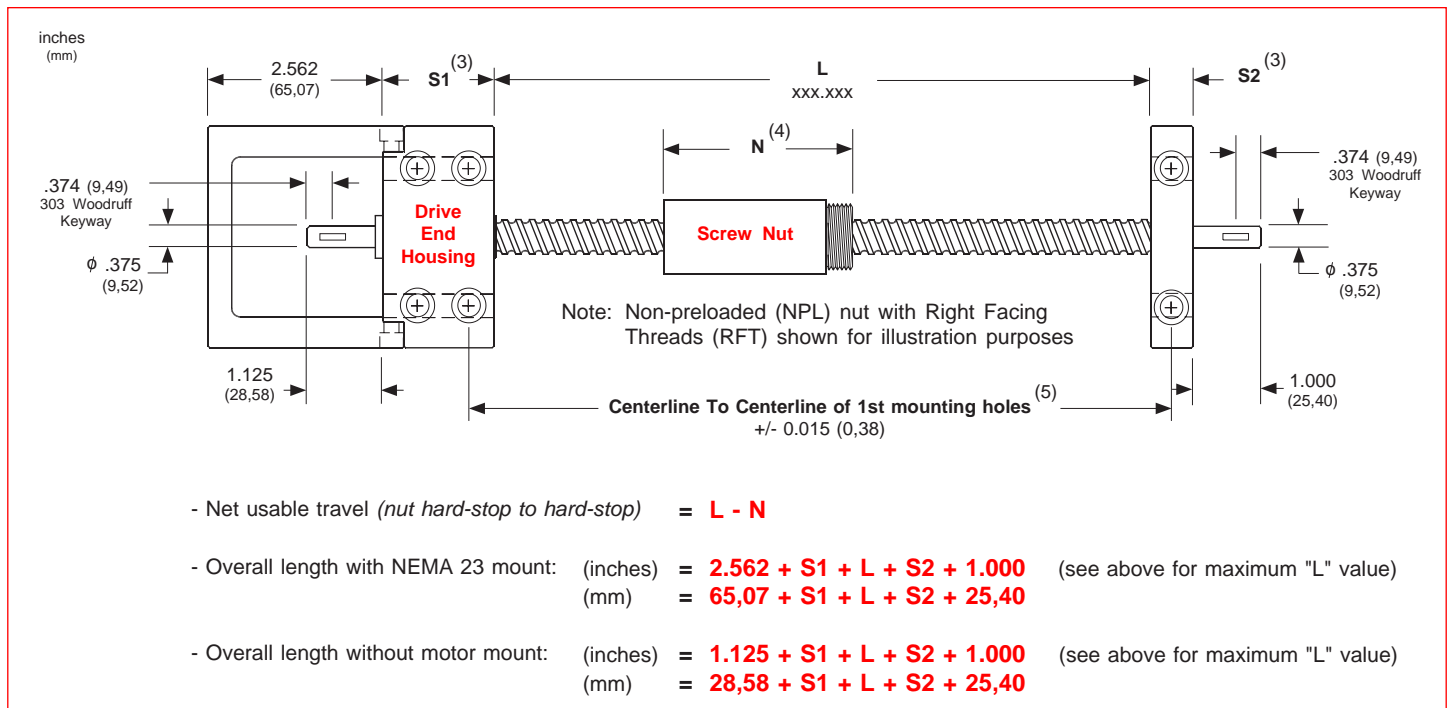

### Footnotes:

- (1) Maximum available standard screw thread length (GS062020 series) for the bearing support housing configuration shown.
- (2) Maximum available standard screw thread length (GS16M05M & GS16M16M series) for the bearing support housing configuration shown.
- (3) Fixed-simple support configuration shown for reference. See page 85 for length values for simple, fixed, and rigid housings.
- (4) See page 84 for available nut styles. Refer to A1 & A2 values for the nut length.
- (5) Tolerance shown is for base mounted support housings. Tolerance also applies to face mounted support housings.

## Performance Charts

### Simple-Simple

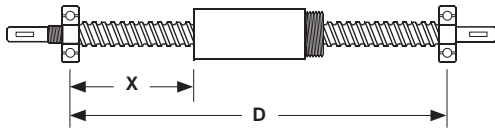

### Rigid-Simple

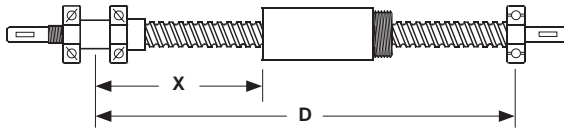

### Rigid-Rigid

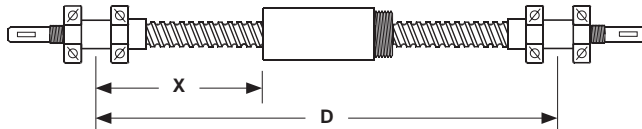

### Maximum Compression Load <sup>(1)</sup>

X inches (mm)	simple-simple		rigid-simple		rigid-rigid	
	lbs	(kgf)	lbs	(kgf)	lbs	(kgf)
20 (508)	1800	(816)	1800	(816)	1800	(816)
30 (1016)	800	(363)	1600	(726)	1800	(816)
40 (1524)	450	(204)	900	(408)	1800	(816)

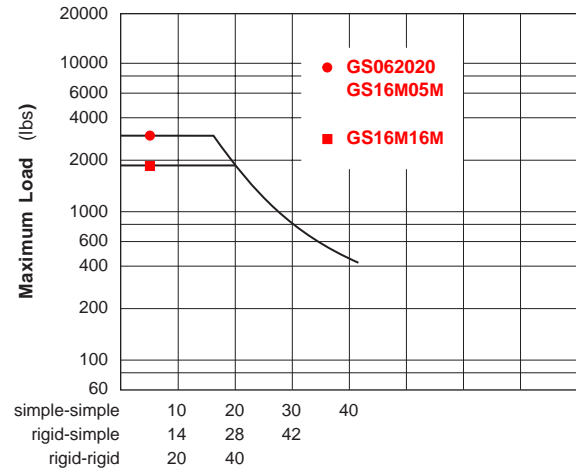

Maximum "X" distance between bearing support and Load (inches)

### Maximum Speed <sup>(1)</sup>

D inches (mm)	simple-simple		rigid-simple		rigid-rigid	
	rpm	rpm	rpm	rpm	rpm	rpm
27 (686)	3000	3000	3000	3000	3000	3000
30 (762)	2405	3000	3000	3000	3000	3000
35 (889)	1765	2600	2600	3000	3000	3000
40 (1016)	1350	1985	1985	3000	3000	3000

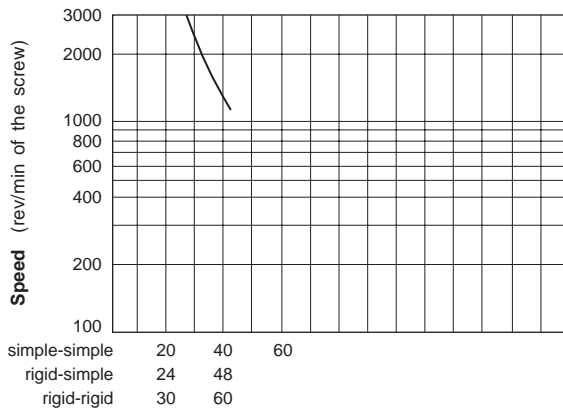

Maximum "D" distance between bearing supports (inches)

### Screw Travel Life

Life millions of inches (km)	062020/16M05M		16M16M	
	lbs	(kgf)	lbs	(kgf)
1 (25)	987	(447)	910	(412)
2 (50)	785	(356)	720	(326)
50 (1270)	270	(122)	243	(110)
100 (2540)	216	(97)	199	(90)

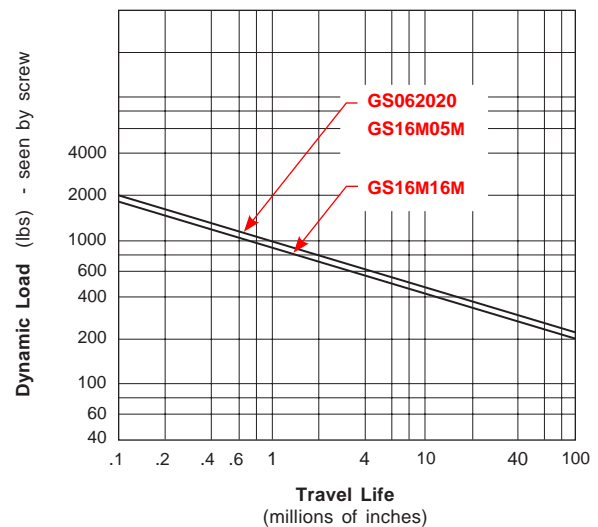

### Footnotes:

- (1) Refer to the simple-simple support lengths for fixed-simple configurations. A fixed housing performs like a simple housing for critical speed and compression load specifications. Maximum speeds may not be reached using a Turcite nut due to system friction.

## Nut Dimensions

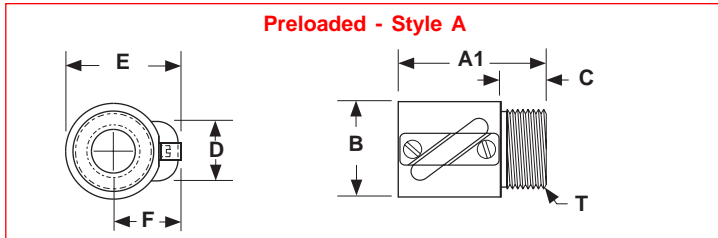

## Nut Flange Dimensions

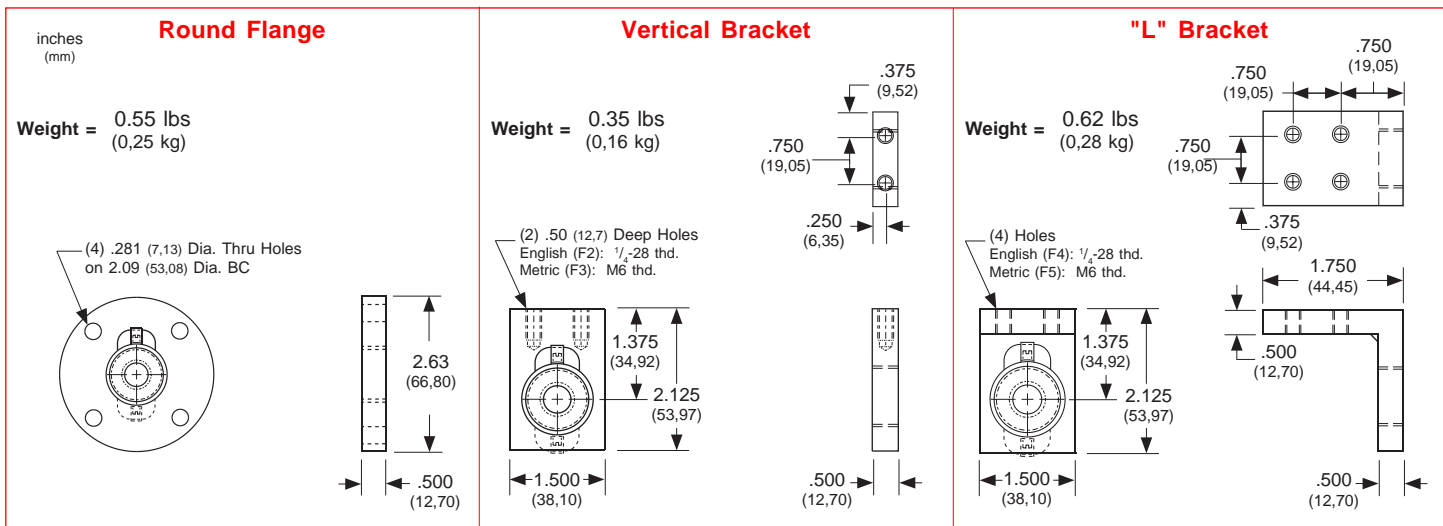

Model Number	Nut Style	Nut Dimensions inches (mm)							Nut Weight lbs (kg)
		A1 <sup>(1)</sup>	B	C	D	E	F	T - "V" Threads <sup>(2)</sup>	
GS062020	A	2.090 (53,09)	1.221 (31,00)	0.500 (12,70)	0.847 (21,51)	1.398 (35,51)	0.788 (20,02)	15/16 - 16 UN-2A (23,81 - 16 UN-2A)	0.24 (0,11)
GS16M05M	A	2.090 (53,09)	1.221 (31,00)	0.500 (12,70)	0.847 (21,51)	1.398 (35,51)	0.788 (20,02)	15/16 - 16 UN-2A (23,81 - 16 UN-2A)	0.24 (0,11)
GS16M16M	A	1.890 (48,00)	1.221 (31,00)	0.500 (12,70)	0.847 (21,51)	1.398 (35,51)	0.788 (20,02)	15/16 - 16 UN-2A (23,81 - 16 UN-2A)	0.30 (0,14)

### Footnotes:

- (1) The preload is achieved internal to the nut. Thus, the GS series preloaded nut is matched to the screw thread.
- (2) All flange threads are internal (Type 2B) to match the external nut threads.

## Support Housing Dimensions

inches (mm)

.625 (15,87)

2.000 (50,80)

(4) .343 (8,71) Dia.Thru Holes

(4) 8-32 x .37 (9,39) Deep on 1.750 (44,45) BC

2.500 (63,50)

1.750 (44,45)

1.250 (31,75)

.375 (9,52)

1.625 (41,27)

3.250 (82,55)

**Simple**

(2) .343 (8,71) Dia. Thru Holes, .504 (12,8) Dia. C' Bored x .57 (14,47) Deep

.313 (7,95)

.625 (15,87)

.313 (7,95)

.625 (15,87)

**Drive End** **non-Drive End**

**Weight = 1.1 lbs (0,50 kg)**

.625 (15,87)

2.000 (50,80)

(4) .343 (8,71) Dia.Thru Holes

(4) 8-32 x .37 (9,39) Deep on 1.750 (44,45) BC

2.500 (63,50)

1.750 (44,45)

1.250 (31,75)

.375 (9,52)

1.625 (41,27)

3.250 (82,55)

.250 (6,35)

**Fixed**

(4) .343 (8,71) Dia. Thru Holes, .504 (12,8) Dia. C' Bored x .57 (14,47) Deep

.750 (19,05)

.500 (12,70)

1.125 (28,57)

(2) 10-32 x .43 (10,92) Deep, both sides

.688 (17,47)

.125 (3,17)

1.750 (44,45)

**Weight = 2.7 lbs (1,22 kg)**

.625 (15,87)

2.000 (50,80)

(4) .343 (8,71) Dia.Thru Holes

(4) 8-32 x .37 (9,39) Deep on 1.750 (44,45) BC

2.500 (63,50)

1.750 (44,45)

1.250 (31,75)

.375 (9,52)

1.625 (41,27)

3.250 (82,55)

.250 (6,35)

**Rigid**

(4) .343 (8,71) Dia. Thru Holes, .504 (12,8) Dia. C' Bored x .57 (14,47) Deep

1.500 (38,10)

.500 (12,70)

1.125 (28,57)

(2) 10-32 x .43 (10,92) Deep, both sides

.688 (17,47)

.125 (3,17)

2.500 (63,50)

**Weight = 3.9 lbs (1,77 kg)**

**NEMA 23 Motor Mount**

**Weight = 0.9 lbs (0,41 kg)**

(4) Holes on 2.625 (66,67) BC Dia. English (M02): #10-24 thd. Metric (M03): M5 thd.

1.502 (38,15) Pilot Dia. TYP

2.340 (59,44)

2.562 (65,07)

.313 (7,95)

1.437 (36,50)

2.250 (57,15)

1.125 (28,57)

(2) .221 (5,61) Dia.Thru Holes, .344 (8,73) Dia. C' Bored x .125 (3,17) Deep, both sides

**NEMA 34 Motor Mount**

**Weight = 1.4 lbs (0,64 kg)**

(4) Holes on 3.875 (98,42) BC Dia. English (M04): #10-24 thd. Metric (M05): M5 thd.

2.877 (73,07) Pilot Dia. TYP

.063 (1,60)

2.340 (59,44)

.500 (12,70)

2.562 (65,07)

.313 (7,95)

1.937 (49,20)

3.375 (85,72)

1.688 (42,88)

.438 (11,13)

(2) .221 (5,61) Dia.Thru Holes, .344 (8,73) Dia. C' Bored x .125 (3,17) Deep, both sides

Specifications subject to change without notice