

Robotic Motor Solutions



KOLLMORGEN®

Because Motion Matters™

Rely on Kollmorgen Solutions

We focus on motion so you don't have to.

Our reputation for enabling robotic innovation continues to grow as Kollmorgen motors deliver motion to new robotic applications every year. With over 100 years of industry experience, we've designed tens of thousands of motors and set hundreds of thousands of robotic joints in motion. This background makes us a unique partner who can meet the technical needs of design engineers and the business needs of your global supply chain. When you're building your brand, failure is not an option. Kollmorgen frameless motors in your robot let you focus on what matters most.



Optimized Capabilities

Modified fit and performance - everytime.

Kollmorgen motors are optimized for fit and performance with harmonic gearing. We offer millions of standard product variations, as well as the local expertise to customize standard motors and produce the best fit inside your robotic joint.

Smaller, Lighter & Faster Robots

Decreased footprint. Increased precision.

Power-dense motors provide a lighter weight and smaller system for improved performance and precision within a compact footprint. Lower cogging torque and minimized poling provide a smoother velocity motion profile to optimize control. Our industry advanced servo motors mean that you can move your ideal robotic arm or system from design to reality and ultimately, to market.

Speed to Market

Reduce your design time. Expand your market availability.

Kollmorgen sets the bar for helping robotic innovators shorten design cycles and get their product to market. Our range of standard, configurable motors – from frameless motors to housed servo and stepper motors - enable quick prototyping and rapid go-to-market strategies.



Industrial Articulated Robots

Across all applications, industrial and manufacturing robots have become smaller and lighter, enabled by Kollmorgen motors with greater torque density.

LIDAR and Autonomous Vehicles

Advanced sensing technology and artificial intelligence (AI) have made autonomous vehicles feasible. Kollmorgen technology can be found in a wide range of applications from steering, to locomotion, to LIDAR, as well as test vehicles across the country. Our range of standard products coupled with our ability to modify designs enables smaller, more compact and lighter systems.

Packaging/Intralogistics/Material Handling/AGV

The world of traditional robotics and AGV is overlapping into smarter, more dynamic and more versatile robots. Artificial intelligence (AI) is advancing with more natural navigation without expensive external sensing markers or reflectors. Kollmorgen's technology is found in a variety of applications including underwater ROV's, drone systems delivering lifesaving materials, agricultural robots, security robots, independent AGV and intralogistics systems, nuclear handling systems and security systems

Surgical Robotics & Automation:

Surgical robots require precise control of multi-axis motion, with coordination across all controls, robotic arms, cameras and instruments. They require complete motion solutions that integrate components designed to work together within the most demanding applications and space constraints. These are Kollmorgen's signature strengths.

Mobile Robots

Mobile robotics take many forms with a wide range of autonomy operating on land, sea and air. These remote and unmanned vehicles are able to operate in difficult environments. Our expertise in Aerospace and Defense markets started in the 1950s when we worked with MIT to develop stabilizing platforms for inertial guidance systems. Today's customers rely on our high torque density and product longevity to ensure mission success.

Collaborative Robots

Collaborative robots (cobots), manufacturing robots and robotic arms are designed to learn and adapt to new tasks as if they are human coworkers. Kollmorgen offers the industry's most advanced servo motors in configurations and torque ranges that ensure safe operation through controlled, precise motion.

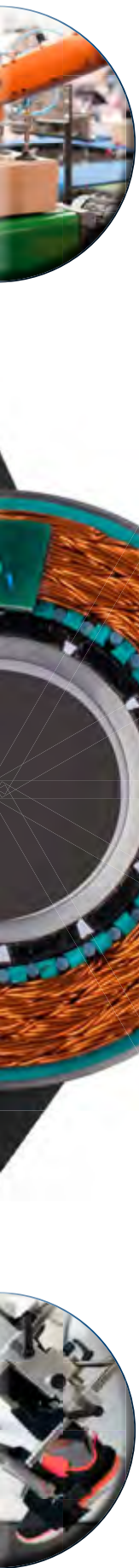

Kollmorgen Standard Solutions

TBM™

Kollmorgen's TBM Direct Drive Frameless Brushless Motor technology is optimized for robotic joint applications that require high power in a small, compact package with minimized weight and inertia. Integrating a TBM into your robotic joint can enable a smaller, more powerful robot in a compact footprint. Our Co-engineering solution options can help you differentiate your next robotic design.

- Three frame sizes
- Multiple stack lengths per frame size
- Multiple windings per frame/stack combination
- Hall sensor option
- Multiple thermal sensors options
- Stainless Steel yokes for maximum corrosion protection
- RoHS Compliant
- Short lead time
- Webtool resource for customer system Performance Curve Generation
- Ideal design for modular machines and flexible manufacturing Systems

KBM™ Series Frameless

The KBM™ Frameless Brushless Motors are high performance motors that can be directly embedded into your robotic application eliminating excess bulk and weight. With a large selection of standard motors—plus our ability to quickly and cost-effectively incorporate co-engineered modifications—you can choose an exact-fit motor that provides the highest performance in the most compact space.

- Fully encapsulated stator windings
- 155°C internal winding temperature continuous capability
- PTC thermistor (avalanche-type) overload protection
- Rare-earth neodymium iron boron magnets
- Fail-safe bands over rotor magnets
- RoHS compliant
- UL and CE agency facilitation
- Optimizations include rotor hub dimensions, stack length, diameter, mounting features, windings, insulation, connection type and much more
- Optional latching digital Hall effect sensors are pre-aligned and factory-installed with added axial rotor length to achieve proper triggering

AKM® Servo Motors

Kollmorgen offers the industry's most advanced servo motors in configurations and torque ranges to meet virtually any robotic specification. Our AKM servo motor has high performance and efficiency that allows you to design a smaller and more compact manufacturing robot. Our AKM Servo Motors offer unprecedented choice and flexibility, such as optional 24 volt and 48 volt windings, and co-engineered modifications for an exact fit into your robotic design.

- 8 frame sizes, 28 frame/stack combinations
- Speeds up to 8,000 RPM
- 75 VDC; 120, 240, 480 VAC windings
- A wide variety of feedback devices, mountings and seals
- Direct mate to most Kollmorgen servo drives
- Windings are rated at 100°C rise over a 40°C ambient while using 155°C (class F) insulation materials
- cURus, CE Compliant, UL Recognition



Kollmorgen Automation and Motion Control



PROGRAMMABLE AUTOMATION SOLUTIONS

Kollmorgen: Your partner. In Motion.

Every solution comes from a real understanding of the challenges facing machine designers and users.

Innovators consistently rate Kollmorgen as one of their best motion systems manufacturing partners. Whether you are looking for classic servo motors, direct-drive servo motors, stepper motors, drives & amplifiers, gearing, actuation, or CNC & multi-axis motion controllers, Kollmorgen is one of the few companies in the world whom actually design and manufacture all of these products.

Our customers are leaders in many industries such as Aerospace & Defense, Printing, Packaging & Converting, Food & Beverage Processing, Medical Imaging, Invitro Diagnostics & Laboratory Automation, Pharmaceutical Manufacturing, Material Forming and Cutting, Oil & Gas, and Robotics. Kollmorgen is also a leader in Warehouse Automation, including complete AGV systems, software, awareness and autonomy.

Our Automation Solutions can be found on Mars and in space, Ships and submarines, O&G drilling and metrology, Surgical robots and laser eye surgery, even inside of artificial hearts. These are just a few applications that demand high performance and high quality while satisfying their specific needs.

Because motion matters, it's our focus: Motion can distinctly differentiate a machine and deliver a marketplace advantage by increasing its performance and dramatically improving OEE.

High-performance motion can make your customer's machine more reliable and energy-efficient, enhance accuracy and improve operator safety. Motion also represents endless possibilities for innovation.

We've always understood this potential, and thus have kept motion at our core and in our Vision, Mission & Values, relentlessly developing products that offer precise control of torque, velocity and position accuracy in machines that rely on complex motion.

Removing the Barriers of Design, Sourcing, and Time

At Kollmorgen, we know that OEM engineers can achieve a lot more when obstacles aren't in the way. So, we clear obstacles in three important ways:

Integrating Standard and Custom Products

The optimal solution is often not clear-cut. Our application expertise allows us to modify standard products or develop totally custom solutions across our whole product portfolio so that designs can take flight.

Providing Motion Solutions, Not Just Components

As companies reduce their supplier base and have less engineering manpower, they need a total system supplier with a wide range of integrated solutions. Kollmorgen offers complete solutions as well as motion subsystems that combine programming software, engineering services and best-in-class motion components.

Global Footprint

With direct sales, engineering support, manufacturing facilities, and distributors spanning the Americas, Europe, Middle East, and Asia, we're close to OEMs worldwide. Our proximity helps speed delivery and lend support where and when they're needed.

Financial and Operational Stability







Kollmorgen is part of Danaher Corporation. A key driver in the growth of all Danaher divisions is the Danaher Business System, which relies on the principle of "kaizen" – or continuous improvement. Using world-class tools, cross-disciplinary teams of exceptional people evaluate processes and develop plans that result in superior performance.

Kollmorgen: Your partner. In Motion.



Table of Contents

	▶ Automation and Motion Control		6	
	Kollmorgen Automation Suite™	8	Human Machine Interface (HMI)	23
	AKD® PDMM™ Drive-Resident Controller	18	I/O Terminal	26
	AKD® PCMM™ Stand-Alone Controller	20	Kollmorgen Developer Network	27
	EtherCAT® Real-time Motion Bus	22		
	▶ Servo Drives		28	
	AKD® Servo Drives		32	
	AKD® -N Decentralized Servo Drives		42	
	▶ Servo Motors		52	
	AKM™ Rotary Servo Motor (up to IP67)		56	
	AKMH™ Hygienic & Washdown Servo Motors (up to IP69K)		64	
	▶ Direct Drive Rotary Motors		74	
	Cartridge Direct Drive Rotary™ (DDR) Motors		76	
	Housed Direct Drive Rotary Motors		80	
	Direct Drive Linear Motors (DDL)		82	
	▶ Frameless Brushless Motors		88	
	KBM™ Frameless Brushless Motors		88	
	TBM™ Frameless Brushless Motors		92	
	▶ Stepper Drives and Motors		94	
	P Series - P5000, P6000, P7000 Drives		96	
	Stepper Motor Overview		100	
	Hybrid PMX Stepper Motors		102	
	AC Series - Synchronous AC Motor Overview		104	
	▶ Servo Gearing		106	
	Micron™ TRUE Planetary™ Gearboxes		107	
	Micron™ AquaTRUE™ IP69K Washdown Gearboxes		110	
	▶ Linear Actuators		112	
	EC & N2 Series Electric Cylinders		114	
	R & N Series Rodless Actuators		120	
	DS Series Precision Tables & Slides		126	

	▶ Permanent Magnet DC Motors (PMDC)	130
	SR Series - SCR-RATED	132
	STF Series - Washdown SCR-RATED	134
	EP Series - Explosion Proof	136
	▶ Optimized Solutions and Special Duty Motors	138
	Optimize Solutions	138
	Custom Capabilities	140
	Proven Design Capabilities	141
	Special Duty Motors	142
	Goldline® S Series Submersible Motors	142
	MX Series Hazardous Duty Motors	143
Hazardous Duty Synchronous Motors	143	
EP Series Explosion-Proof Motors	143	
	▶ Servo Drive Accessories and Cables	144
	Drive System with AKD-x00306...02406	146
	Mechanical Accessories for AKD-N Drives	148
	Motor Chokes	150
	Mains Chokes	152
	Mains Filters	154
	Regen Resistors	158
Capacitor Modules	162	
AKD® Performance Cables	164	
	▶ Warehouse (NDC) Solutions	170
	AGV Control Systems	172
	▶ Model Nomenclature	176
	▶ MOTIONEERING® Online	199

 **Individual, comprehensive selection guide PDF's:**



Automation and Motion Control

Comprehensive Line of Products Offering Complete System Solutions

Kollmorgen's comprehensive line of control software and hardware, drives and motors enables you to complete your solutions with one supplier:

Whether you want a stand-alone controller or drive-resident, Kollmorgen's KAS can coordinate up to 128 axes, and synchronize the path of up to 32 axes per control engine. We offer standard languages according to IEC61131 -3, as well as C, C+, C++, C#, .NET, and our industry-leading graphical programming language, Pipe Network.

Our broad range of motor- and drive technologies and gearing and actuation products interface seamlessly with our KAS.



The AKD PDMM multi-axis motion controller is equipped with an AKD servo drive for direct connection to a motor. Additional axes each with their own AKD servo drive are controlled by the AKD PDMM via the system bus with the EtherCAT® protocol; extremely precise with cycle times of 250 µs. Optionally, an AKI control panel with one of the standard communication protocols can be connected for operating the machine. The AKD PDMM supports all leading bus systems and thus opens up limitless control system options. The PDMM motion controller functionality is also available in a stand-alone package, the PCMM, for machine designers that prefer traditional, independent controller hardware.

Control of motors with AKD® PDMM programmable multi-axis master

Flexible single or multi-axis drive solutions in decentralized and central architectures with AKD-PDMM and the Kollmorgen Automation Suite

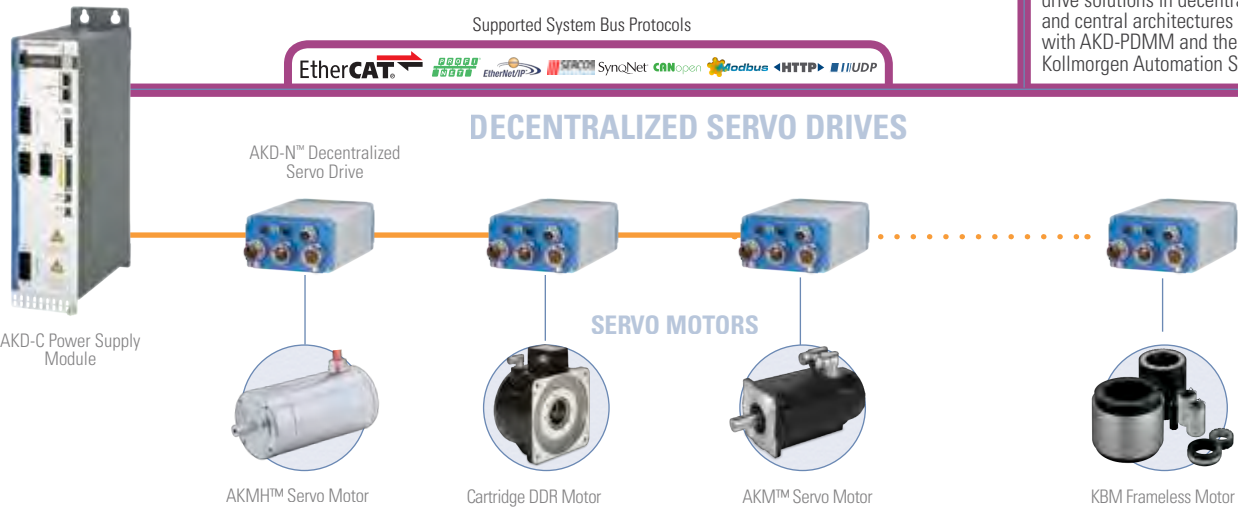

AUTOMATION AND MOTION CONTROL

Diverse and Scalable Drive Solutions

Need more axes? Different motor types? Linear direct drives here, direct drives with no housing there? No problem! With the EtherCat® system bus you can connect more AKD servo drives and add motors of all performance classes from the Kollmorgen product range.

Interfaces are frequently the bottleneck in system design. Not so with the Kollmorgen Automation Suite. With the AKT (Advanced Kollmorgen Terminals) IO bus terminals and the EtherCat® bus coupler, you possess a flexible interface system which meets all of your requirements.

Control and monitor the processes on the machine with the AKI series touch panels. With the KVB (Kollmorgen Visualization Builder), you can program ergonomic user interfaces which guarantee safe handling and which display machine data clearly.

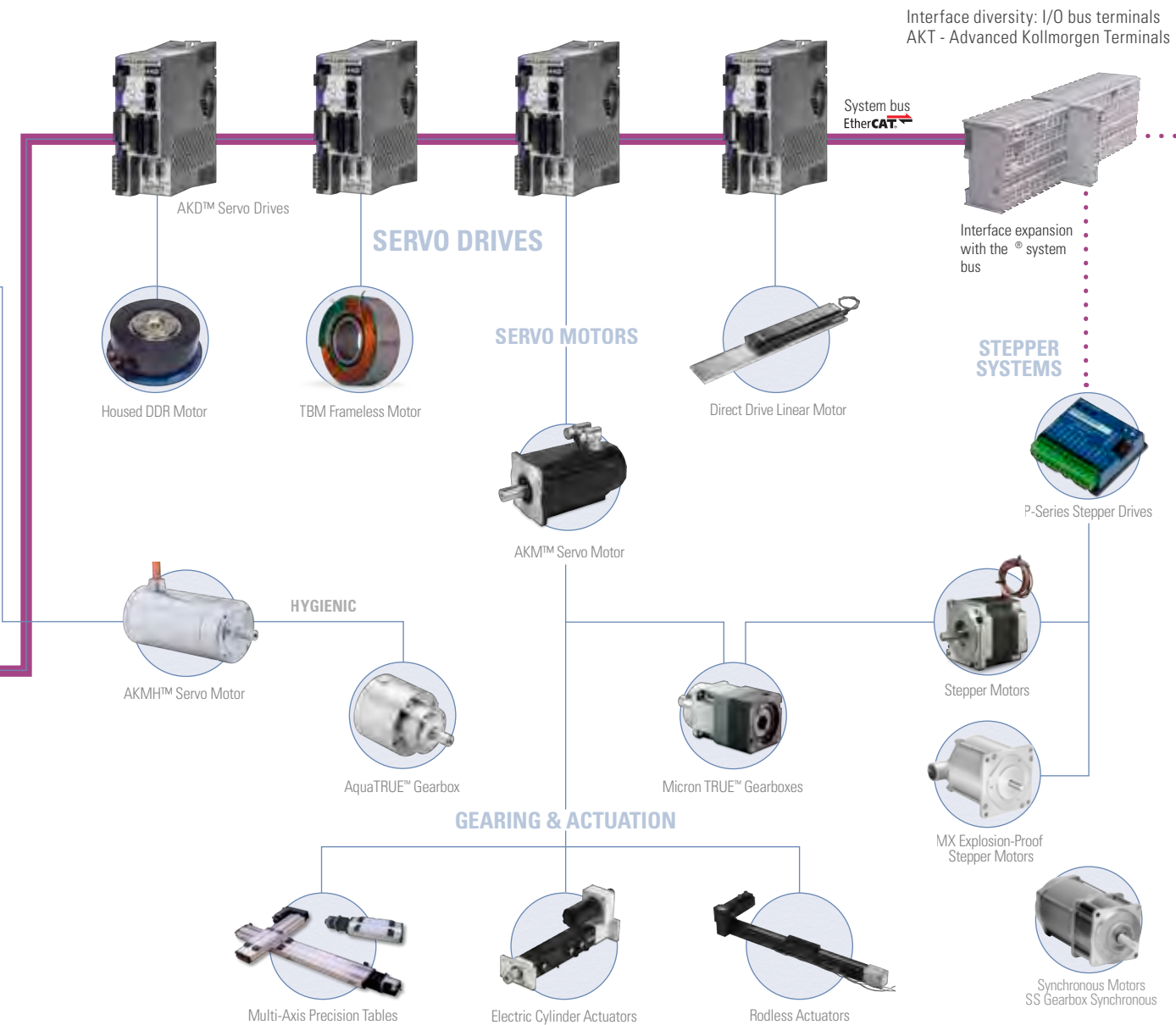

Kollmorgen Automation Suite™

Kollmorgen's machine automation platform dramatically simplifies how you approach the many complex automation challenges of today's machines. We have created an integrated development environment (IDE) that greatly simplifies programming and system configuration and combines multiple tools into one intuitive platform, we have global support and experience engineering services to solve your biggest challenges, and our best-in-class automation and motion components deliver unparalleled motion performance; all of which combine to help you create a differentiated machine, get to market faster, and have the comfort and ease of collaborating with just one vendor.

Integrated Development Environment – Quickly and easily design, refine and troubleshoot all of a machine's automated solutions in this highly intuitive application featuring a single programming environment that provides great flexibility and control.

Engineering Services – A Kollmorgen representative establishes a collaborative, consultative relationship from the beginning by assessing needs and objectives. Field engineers and application engineers constantly support the design and build phase as well as the factory installation phase to ensure that your needs are met from concept to production. Additional services are available that include development, on-site deployment, and training.

Best-in-Class Automation and Motion Components – With Kollmorgen, there's security in knowing the necessary components that form the building blocks of a machine are always available. No one offers a wider range of standard, modified standard and custom products. Motion is at the core of our Automation suite, where others in the industry consider it an add-on.

Kollmorgen Co-engineering – More than a solutions provider, we Co-engineer a better fit with your company using both products and services. From a wide breadth of product modifications, over 500,000 standard options with 5-day delivery on our AKM line, to aftermarket revenue protection and training programs, Kollmorgen Co-engineering helps you differentiate your machine and business.

We accept your challenges as our own. That's the Kollmorgen Co-engineering difference.

The Advantages of Kollmorgen Automation Suite

- High machine performance
 - Up to 25% greater throughput
 - Up to 50% scrap reduction
 - Improved accuracy
 - Advanced drive technology for machines with outstanding performance
- Fast to market
 - Up to 30% reduction in development time
 - Services available for program development, training, start-up, and support
 - Industry standard programming environment and industrial networks
- Enhanced ease-of-use and integration
 - Single integrated programming environment for automation, drive technology, and all hardware
 - Drag-and-drop motion programming
 - Certified components that are tested to work together
 - Seamless integration and configuration of amplifiers for optimal set-up
- A demonstrated solution
 - The result of over 20 years of permanent optimization of programming and implementing automation and drive solutions
 - Provides the diverse experience of a great number of suppliers and platforms that form today's Kollmorgen
 - Used successfully for more than 6 years

Scalable Programmability

KOLLMORGEN AUTOMATION SUITE

Kollmorgen delivers cutting-edge technology and performance with the AKD® servo drive and KAS controls platform. Whether your application requires a single axis or over 100 fully synchronized axes, Kollmorgen's intuitive software and tools scale to meet your needs. From simple analog torque control to the latest high-performance automation network, the AKD servo drive packs power and flexibility for virtually any application into one of the most compact footprints of any digital servo drive in the industry.

- Patented auto-tuning delivers optimized performance in seconds.
- 1.5MHz current loop and 16KHz velocity loops offers greater bandwidth and performance
Optimized performance in seconds
- Greater throughput and accuracy
- Easy-to-use Graphical User Interface (GUI) for faster commissioning and troubleshooting
- Flexible and scalable to meet any application



Motion Tasking ("P" Option)

- Adds simple point-and-click indexing to base drive
- Provides user with pre-programmed options
- Guides novice user through simplified steps to create indexing moves
- Network connectivity to EtherCAT®, CANopen®, Profinet®, Ethernet/IP™, TCP/IP, SynqNet™ and others
- MODBUS port for communication with HMI

BASIC Programmable 1.5 Axis Drive ("T" Option)

- Adds BASIC programmability to base AKD
- 4KHz programmable interrupt service routines
- Conditional statements, built-in math functions, user functions and subroutines
- Includes 2 high-speed digital inputs
- Same package size as base drive
- Expandable to 31 digital I/O and 4 analog I/O
- Optional integrated SD card for easy backup and drive cloning
- Includes electronic camming functionality

- Controlled by analog torque-and-velocity commands
- Includes electronic gearing via X9 connector
- Includes access to 11 digital I/O and 2 analog I/O on base drive
- Includes 2 high-speed digital inputs
- Expandable to 31 digital I/O and 4 analog I/O

Basic Operation

Single-Axis

RANGE OF KOLLMORGEN AUTOMATION SUITE CAPABILITIES

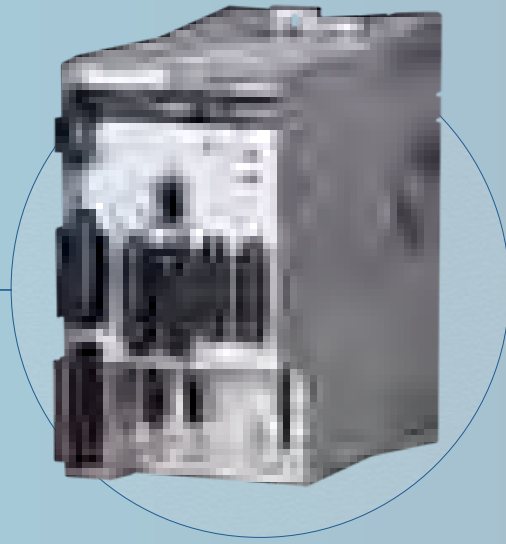
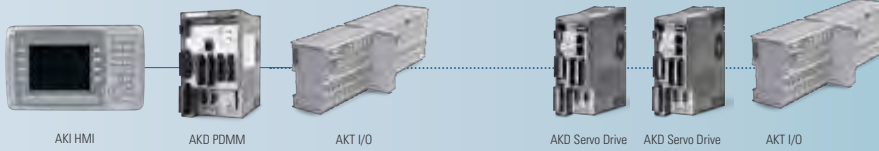

KOLLMORGEN AUTOMATION SUITE

Programmable Drive Multi-Axis Master PDMM ("M" Option)

Seamlessly add additional axes and AKD PDMM serves as a high-performance multi-axis machine controller

- Scalable solution for use as a single-axis drive with integrated programmable automation controller
- Choose from all five IEC 61131-3 languages for soft PLC process programming
- Program motion using your choice of PLCopen for motion or our innovative Pipe Network™
- 4KHz PLC scan rate and EtherCAT® updates
- Complete line of HMI panels with integrated software to simplify GUI development
- Exclusive function blocks, such as "wait," enable your program to act as a scanning or sequential language
- On-board I/O includes 17 digital (with 2 high speed inputs) and 2 analog
- Connects to AKT™ network I/O for nearly unlimited expandability
- SD card for easy backup and system updates
- IoT-enabled integrated webserver for diagnostics and troubleshooting from any computer or mobile device
- Provide true synchronized-path control of up to 16 axes
- Reduce cabinet size and wiring requirements with a single, compact package
- Easily manage remote I/O and the I/O of all attached drives via EtherCAT®
- Use industry standard PLCopen for motion, or step up to Kollmorgen's Pipe Network™ to program sophisticated camming and gearing applications in a matter of minutes



Pipe Network™ Kollmorgen Visual Motion Programming

- Accelerate development by programming tasks in hours that would otherwise take weeks
- Improved coding quality through visual programming and by using pre-built modules that have been thoroughly tested and optimized
- Easy knowledge transfer, replacing pages of complex code with easily understood graphical representations
- Available on PDMM™ controllers

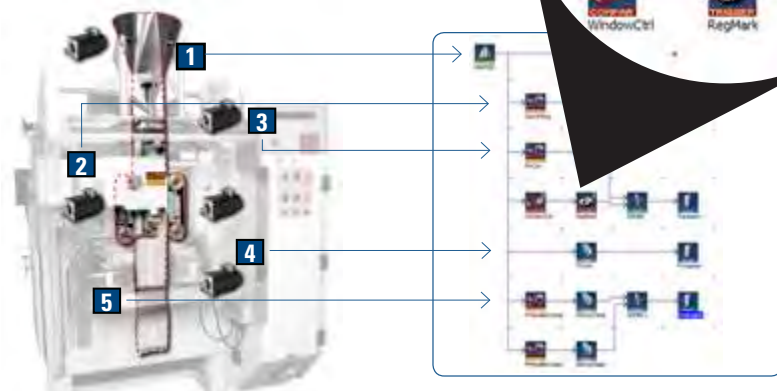

Pipe Network provides a one-to-one translation of a mechanical system into a logical world as shown in the Vertical Form Fill and Seal machine above. Click and build your motion program in minutes, or contact Kollmorgen for examples of common machine architectures to further accelerate your development.

Programming

Multi-Axis Programming

Development

A fully integrated development environment (IDE) provides the tools you need to develop everything from PLC and motion programs to HMI and device setup – all in one place. It's easier to learn and use, eliminates the need for multiple programs and data stores, and helps you bring a higher-quality machine to market faster.

Integrated Development Environment (IDE)

- Our fully integrated programming environment incorporates standard IEC61131-3 compliant tools.
- Use our network configurator and predefined user blocks to streamline development and ensure programming quality.

Our IDE offers two powerful programming methods and a complete set of tools for simulating, testing and optimizing motion.

Embedded Motion

- Choose PLCopen for motion if you already use this industry standard in your existing products, and want to continue using it within the Kollmorgen Automation Suite programming environment.



Embedded wiring diagrams and one-click IO variable mapping makes drive integration easy.

Integrated Tools

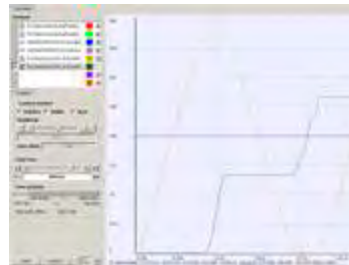

Scope motion parameters to fine-tune performance and synchronization, portrayed with up to eight channels and flexible mapping of variables.

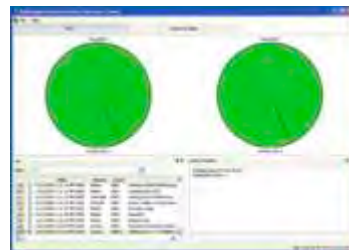

One-click motion simulation using virtual axes alongside real axes for quick development and implementation.

Pipe Network™ Kollmorgen Visual Motion Programming

- Choose Kollmorgen's exclusive Pipe Network™ for the quickest, easiest way to represent mechanical systems in software – using drag-and-drop tools to create an intuitive visual representation.



Complete motion system configuration from one location with embedded AKD Workbench allows configuration of all servo drives over EtherCat®.

Lifecycle

Kollmorgen is committed to helping you maximize the productivity and profitability of your machine across an extended lifecycle. Design and build today, with confidence for a full return on investment for years to come.

Continual Development Testing

Kollmorgen develops, tests, and continually validates all new products to ensure compatibility and performance, in the Kollmorgen ecosystem.



Maintenance Support Tools

Our tools give end-users the ability to remotely verify continuous operation and communicate issues effectively.



Built-in, mobile-ready webservice provides performance information with no software required

Software and Hardware Security

Password protection for source code and hardware connectivity provides security for both OEMs and end-users.



- ✓ **Protect source code**
- ✓ **Protect network access**

Software PLC

Easy-to-Use, Auto-Discover, Auto-Recognize, Auto-Configure, Scope, CAM, IEC 61131-3 PLC

- Kollmorgen Automation Suite offers a set of tools that is familiar to automation programs, but has enhancements like predefined motion blocks and visual diagnostics tools.

IEC 61131-3 Toolkit Features	<ul style="list-style-type: none"> • IEC-61131-3 engine • Re-compile while running animated variables • Industry and application Specific Function Blocks 	<ul style="list-style-type: none"> • PID temperature control block • Debugger Tools with Watch window • 8-channel Real-Time Oscilloscope
-------------------------------------	--	---

- The environment for developing PLC programs has been created with an emphasis on speed. Recognize and configure motion control components to accelerate systems development. With auto-recognize and auto-configure features, testing efforts are reduced.
- Once an application or a function block has been created for a given application, the user can store this as a “user-defined function block” to promote reuse of tested software in subsequent projects to save time.
- Maintain your standards in corporate programming languages by using any of the IEC 61131-3 languages. In fact, enhance it further by mixing and matching languages to deliver the best solution for the application.

The image displays four different PLC programming languages side-by-side:

- Sequential Function Chart (SFC):** Shows a vertical sequence of four steps (1-4) with associated variables like RELSTATUS_INIT and RELSTATUS_STOP.
- Function Block Diagram (FBD):** Shows a network of function blocks connected by lines, including a 'Machine_Enable' block and a 'HLAxisPower' block.
- Ladder Diagram (LD):** Shows a traditional ladder logic network with normally open and closed contacts, and coils for outputs.
- Structured Text (ST):** Shows a text-based program with comments and function calls. Key lines include:

```
On Machine_Enable: TRUE; DO //Enable Axis
  HLAxisPower( PipeNetwork.AXIS1 22,
  HLAxisPower( PipeNetwork.AXIS2 31,
END_DO;

IF Machine_Enable
  HLAxisPower( PipeNet.
END_IF;

//Stop Motion button pr
ON b_GC_StopMotion
  HLHstRun( PipeNetwor
  b_GC_StartMotion (B
END_DO;
```
- Instruction List (IL):** Shows a list-based instruction set:

```
Begin_IL
  LD Input1 TRUE
  AND Input2 FALSE
  JNFC Test
  //Store Result
  ST Output
  JRP End

Test:
  //Score Input1
  LD Input1 TRUE
  ST Output FALSE

END:
END_IL
```

All five IEC 61131-3 PLC languages are supported

- Kollmorgen Automation Suite’s integrated development environment (IDE) allows the developer to create solutions without having to connect a single device by using the offline simulator. Start creating systems before the first hardware component is delivered. Simply configure your system network in “offline development” mode and change the status of the devices one-by-one when you actually connect them.



*Automatic I/O variable creation with scope definitions
 Adding bus couplers with I/Os onto a motion network topology*

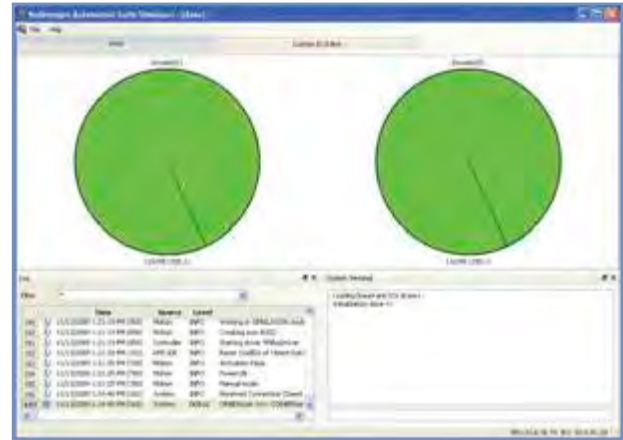

Simulator with PLC simulation and motion

- Standard debugging features like “step into”, “step over”, etc. are available to troubleshoot programs. In addition, debug your code using the softscilloscope and continuously plot up to 8 variables at network update rates – the display can also be configured to suit the scale that the developer desires.
- Our CAM editor lets you create complex CAM profiles using a graphical interface. When converting, it is also possible to import existing CAM profile points into the CAM editor to allow you to seamlessly reuse your existing profiles.
- CAM-on-the-Fly lets you change CAM profiles based on network inputs or changes in machine conditions.

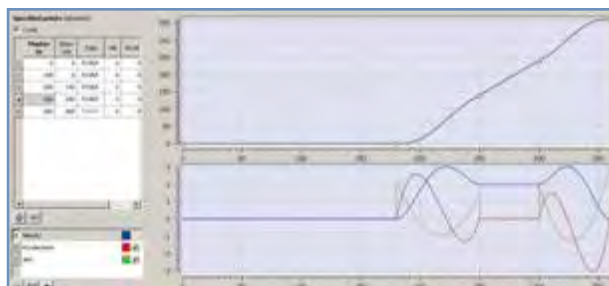

Graphical environment for creating CAMs

Motion Programming



Our motion control solutions are backed by Kollmorgen's vast experience solving application-specific problems for the many industries we serve. Kollmorgen Automation Suite™ offers several advantages that have helped our customers accelerate the development of more precise, high-performance motion. For example:

Superior machine synchronization, with motion-optimized runtime engine and deterministic EtherCAT® network:

- IEEE1588 distributed clock correction
- Hardware-based synchronization
- PLC code execution at EtherCAT® update rate, eliminating process delay
- Low hardware latency

Flexible profile generation, allowing problem-solving through multiple methods branching out of standard pre-packaged tools:

- Pre-loaded and user-defined motion blocks optimized for specific industries and applications
- Configurable through Pipe Network™ and PLCopen for motion

Motion Capabilities

- Absolute and incremental moves
- Jerk-limited moves (S-curve)
- CAM profiles (static or with “on-the-fly” profile changes)
- Gearing (EtherCAT® synchronized)
- Multiple high-speed registration methods (FPGA-based capture engine)
- Homing
- Tension control based motion
- Motion-based functional safety
- Superimposed moves
- Phase adjust
- Multi-axis interpolated motion

Program motion quickly and intuitively with our Pipe Network™ graphical programming language. Or choose the industry-standard PLCopen for motion to easily reuse your existing programming resources.

Pipe Network™ Visual Programming Environment

Our innovative Pipe Network™ programming environment provides a visual, drag-and-drop model of your machine's motion, including complex axis and cam relationships.

Program Tasks in Hours Instead of Weeks:

- Intuitive visual programming with a library of prebuilt modules.
- Easy knowledge transfer, replacing pages of complex code with easily understood graphical representations

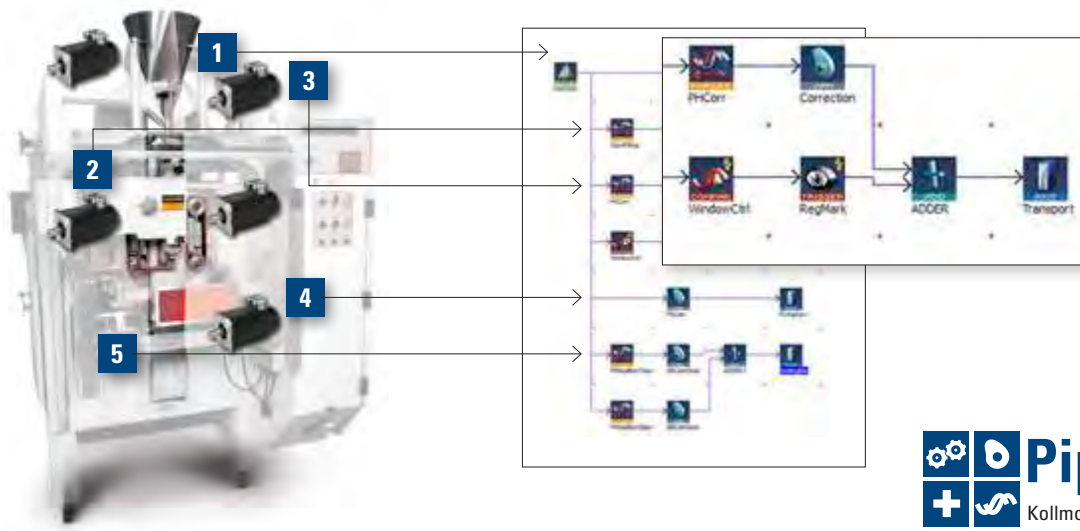

Pipe Network™ provides a one-to-one translation of mechanical systems into a logical world, so you can click and build your motion program in minutes – as shown in this example of a vertical form-fill-seal machine.



PLCopen for Motion

The Kollmorgen Automation Suite™ IDE incorporates PLCopen for motion, a widely accepted open industry standard.

In the example shown here, PLCopen for motion is used within the Kollmorgen Automation Suite IDE to precisely control axis position based on registration marks:

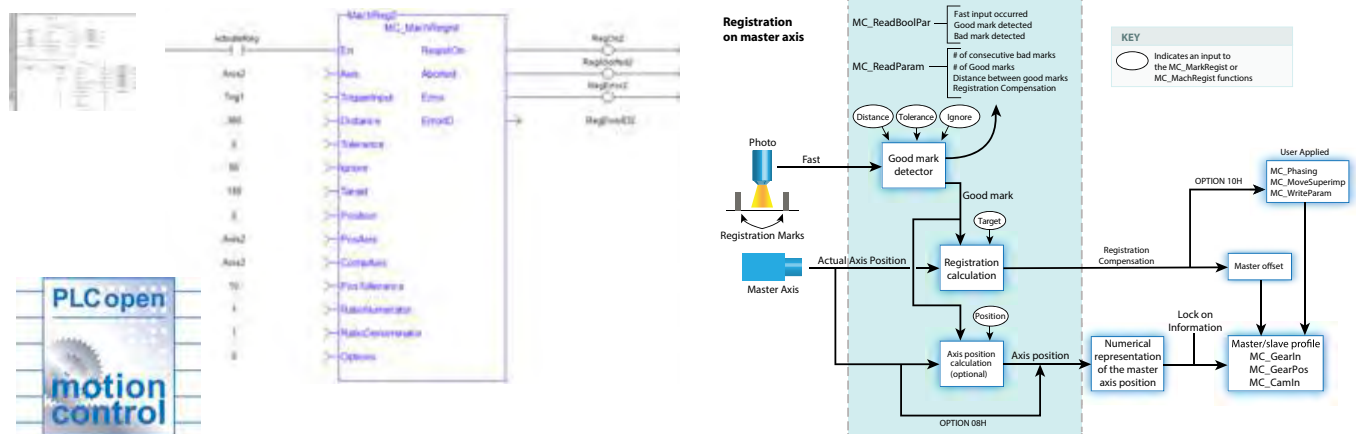

AKD[®] PDMM[™] Drive-Resident Controller

Build Simpler and Better with Drive-Resident Machine and Motion Control

Extend your design options. Control as many as eight axes or more without the need for a PLC or PAC. Reduce cabinet space and wiring requirements. Program perfect machine and motion control for any project using a single, fully integrated programming environment. Build a better machine at a lower cost.

Our new addition to the AKD[®] drive family combines one servo axis, a master controller that supports multiple additional axes, and the full automation capability of Kollmorgen Automation Suite[™]—all in a single, compact package.

Welcome to the AKD PDMM[™] programmable drive, multi-axis master.

Performance Specifications

120/240 Vac 1- and 3-Phase	Continuous Current (Arms)	Peak Current (Arms)	H (mm/inches)	W (mm/inches)	D (mm/inches)
AKD-M00306-MCEC-0000	3	9	168 / 6.61	89 / 3.50	156 / 6.14
AKD-M00606-MCEC-0000	6	18	168 / 6.61	89 / 3.50	156 / 6.14
AKD-M01206-MCEC-0000	12	30	196 / 7.72	107 / 4.22	187 / 7.36
AKD-M02406-MCEC-0000	24	48	248 / 9.76	96 / 3.78	228 / 8.97

240/400/480 Vac 3-Phase	Continuous Current (Arms)	Peak Current (Arms)	H (mm/inches)	W (mm/inches)	D (mm/inches)
AKD-M00307-MCEC-0000	3	9	256 / 10.08	99 / 3.90	185 / 7.28
AKD-M00607-MCEC-0000	6	18	256 / 10.08	99 / 3.90	185 / 7.28
AKD-M01207-MCEC-0000	12	30	256 / 10.08	99 / 3.90	185 / 7.28
AKD-M02407-MCEC-0000	24	48	306	99 / 3.90	228 / 8.98
AKD-M04807-MCEC-0000	48	96	385	185 / 7.28	225 / 8.85

Features

- Kollmorgen Automation Suite[™] provides fully integrated programming, testing, setup and commissioning
- Embedded web server utility simplifies service
- Control 32 axes or more* while reducing machine footprint
 - EtherCAT[®] multi-axis master motion controller integrated with a standard AKD[™] drive axis
 - Full IEC61131-3 soft PLC for machine control, with support for all 5 programming languages
 - Choice of PLCopen for motion or Pipe Network[™] for programming motion control
 - 32 KB non-volatile memory stores machine data to eliminate scrap upon restart after power failure
 - SD Card slot simplifies backup and commissioning, with no PC required
 - On-board I/O includes 13 digital inputs, 4 digital outputs, 1 analog input, 1 analog output (expandable with AKT series of remote I/O)
- Works with Kollmorgen Visualization Builder for programming AKI human-machine interface panels



*Maximum axis count depends on motion/automation complexity and performance (8 axes nominal based on medium complexity at 4 kHz network update rate)

A Single, Scalable Development Suite

Kollmorgen Automation Suite™ simplifies and accelerates development through a unified system of software, hardware, and collaborative co-engineering. This scalable solution provides a fully integrated development environment for any application, whether you're programming a single axis of motion, a multi-axis AKD PDMM™ system, or a PCMM-based system up to 64 axes or more. Kollmorgen Automation Suite has been proven to:

- Improve product throughput by up to 25% with industry-leading motion bandwidth
- Reduce scrap by up to 50% with world-class servo accuracy, seamless power-failure recovery and highly dynamic changeovers
- Increase precision for better quality, reduced waste and less downtime using EtherCAT®—the field bus with motion bus performance
- Enable more adaptable, sustainable and innovative machines that measurably improve marketability and profitability

A Single Family of Servo Drives

Kollmorgen AKD™ servo drives deliver cutting-edge performance in a compact footprint. From basic torque-and-velocity applications, to indexing, to multi-axis programmable motion, these feature-rich drives offer:

- Plug-and-play compatibility with your servo motor
- All the advantages of Kollmorgen's breadth of motor platforms including AKM™, CDDR™, and other direct-drive technologies
- The fastest velocity and position loop updates
- Full-frequency auto-tuning for perfect motion across the performance spectrum
- Real-time feedback from a wide variety of devices

Our Best Drive and Automation Solution in a Single Package

The new AKD PDMM programmable drive, multi-axis master combines our AKD drive platform with the full feature set of Kollmorgen Automation Suite in a single package—providing complete machine and motion control for up to eight axes or more.

You need only one development suite and one drive family for all your projects. And you can rely on one source for all the motion components and co-engineering expertise you need to build a better machine.

With AKD PDMM, the best in machine engineering has never been easier, faster or more cost-effective.

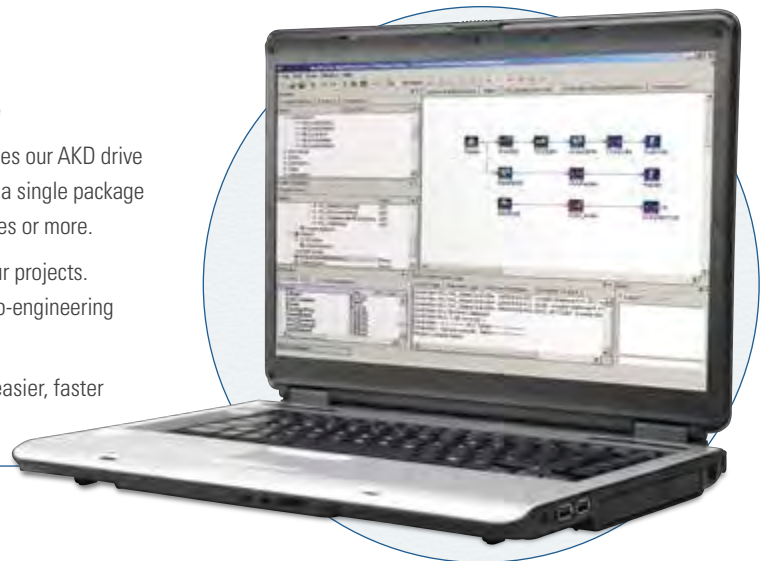

PCMM™ Stand-Alone Controller

KOLLMORGEN AUTOMATION SUITE

Powerful Motion Controller in Small and Simple Package

The PCMM programmable motion controller delivers the same features as the drive-integrate AKD-PDMM controller, but in a stand-alone package that offers flexibility when used with AKD-N/C decentralized drives and for machines where the benefits of an integrated drive and controller are not required.

Ideal for OEMs that want to reduce cabinet space and machine complexity without sacrificing performance, the PCMM delivers full PLC functionality, a high-performance motion control and EtherCAT® master in one small package that easily installs in any electrical panel. Plus, programming is made easy using KAS IDE which includes PipeNetwork™ visual programming, one-click simulation, and integrated configuration and diagnostic tools simplify machine development and help you get to market faster.

Part Number	Processor
AKC-PCM-M1-120-00N-00-E00	800 MHz Standard Multi-axis Controller
AKC-PCM-MC-80-00N-00-E00	1.2 GHz High Performance Multi-axis Controller

General Features and Specifications

Processor	Available with 1.2GHz or 800MHz CPU
Internal Memory	64 MB Flash memory for program storage
External Memory	Removable SD card (not included)
Input Power	24 Vdc @ 1.25 A
Operating Temperature	0 °C - 40 °C
Sealing	IP20
Local I/O	6 digital inputs, 2 digital outputs
Motion Network	EtherCAT®, max 4kHz update rate
PLC Programming	IEC-61131-3, support for all 5 languages
Motion Programming	PLCopen or PipeNetwork®
HMI Programming	KVB programming for AKI panels
Dimensions	174mm (H) x 46.6mm (W) x 111.5mm (D)
Certifications	CE / UL (planned)

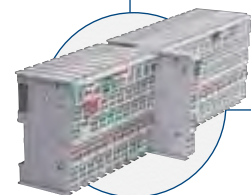
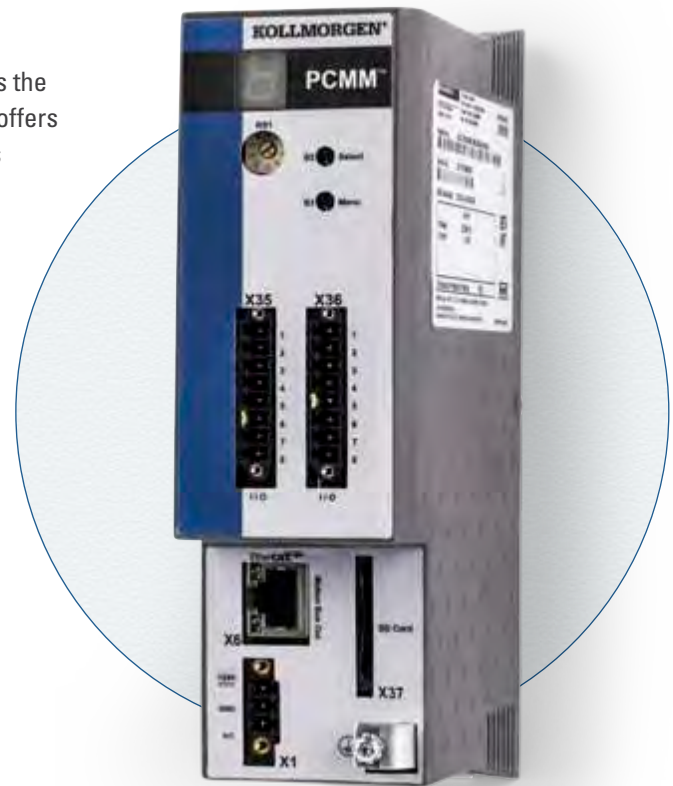

I/O

PCMM™ Hardware Features

- Up to 1.2GHz CPU meets the performance requirements for a broad range of machines
- Control 1 to 30 or more axes with a single controller
- 100BaseT connection supporting TCP/IP, MODBUS, EthernetIP®, Profinet® to host PLC, computer, or network to easily interface with most manufacturing systems
- Cycle times as low as 250 µs
- Alphanumeric display for fast diagnostics and system troubleshooting
- Removable SD memory card for simple backup/restore and file storage
- On-board digital I/O with support for expansion I/O via EtherCAT®
- Compact size reduces cabinet space and cost

PCMM™ Software Features

- IEC 61131-3 programmable automation and motion controller
- EtherCAT® master for high-performance motion and device synchronization
- PipeNetwork™ motion engine for visual programming
- Embedded RTOS for guaranteed performance and stability
- Integrated webserver for remote diagnostics and status checking
- Ideal design for modular machines and flexible manufacturing systems

PCMM™ System Integration

- Seamless integration with Kollmorgen's AKD® servo drives, AKM® rotary servo motors, AKI® HMIs, and AKT® fieldbus I/O modules for complete automation solution
- Network communication via OPC, MODBUS, TCP/IP, UDP, and common fieldbus for fast integration into your machine or factory
- Intuitive EtherCAT® configuration tools built into KAS IDE simplifies network configuration
- Integrated Kollmorgen Workbench® for rapid servo tuning and machine optimization

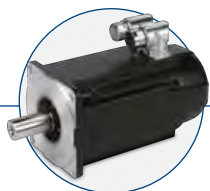
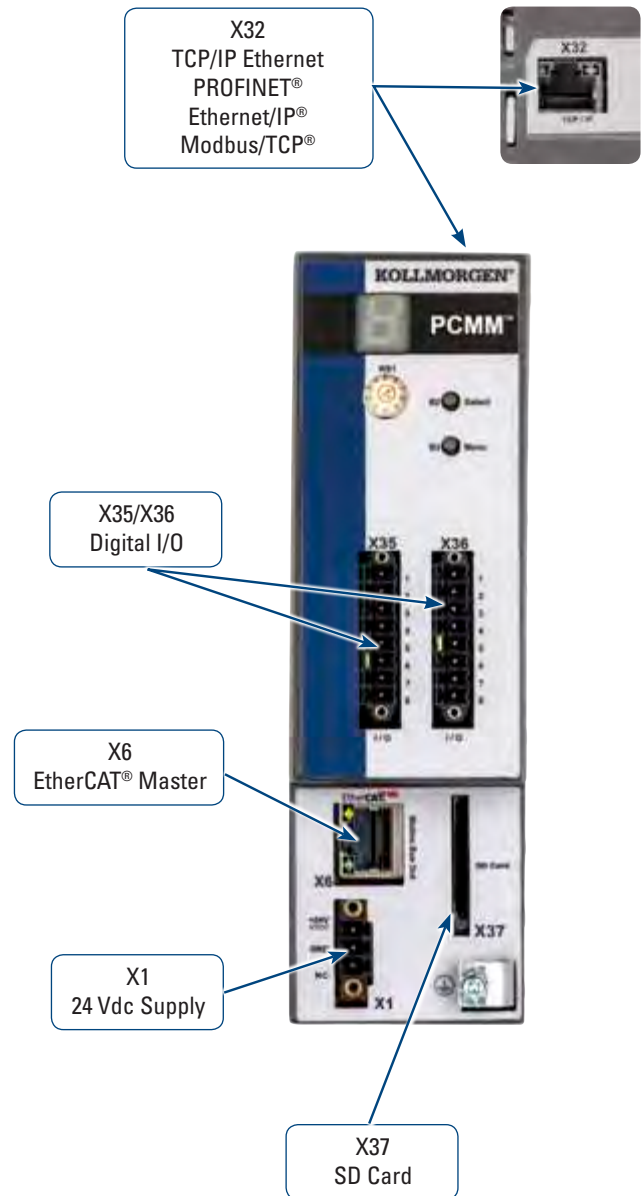

AKM® Servo Motor



AKD®-N Servo Drive



AKD® Servo Drive



HMI

Real-time Motion Bus



EtherCAT® Real-time Bus for Motion and I/O Connectivity

- Auto-recognition of Kollmorgen Automation Suite-compatible components
- Guaranteed real-time update cycle down to 250 microseconds.
- Supported by 2000+ member companies
- Standard Ethernet cabling = lower implementation cost
- Interoperability with other buses
- Wide availability of devices

EtherCAT® Performance Overview

Process Data	Update Time
256 distributed digital I/O	11 μ s = 0.01 ms
1000 distributed digital I/O	30 μ s
200 analog I/O (16 bit)	50 μ s – 20 kHz
100 Servo Axis, with 8 Bytes input and output data each	100 μ s
1 Fieldbus Master-Gateway (1486 Bytes Input and 1486 Bytes Output Data)	150 μ s

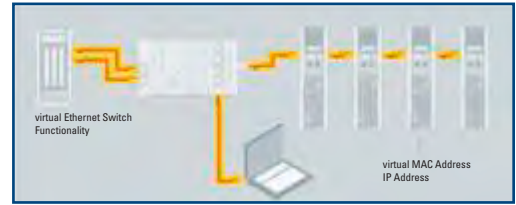

Transparent for all Ethernet protocols

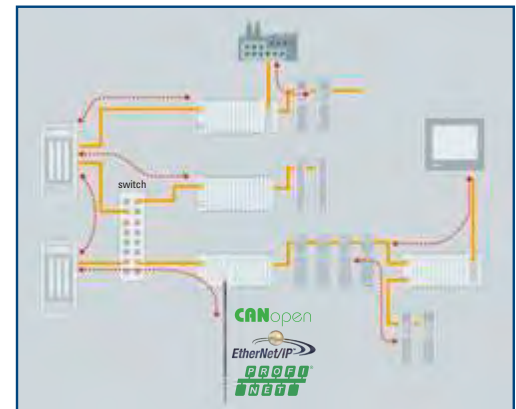

Versatile network architecture

Kollmorgen EtherCAT® Bus Coupler

See page 26 for models and configurations

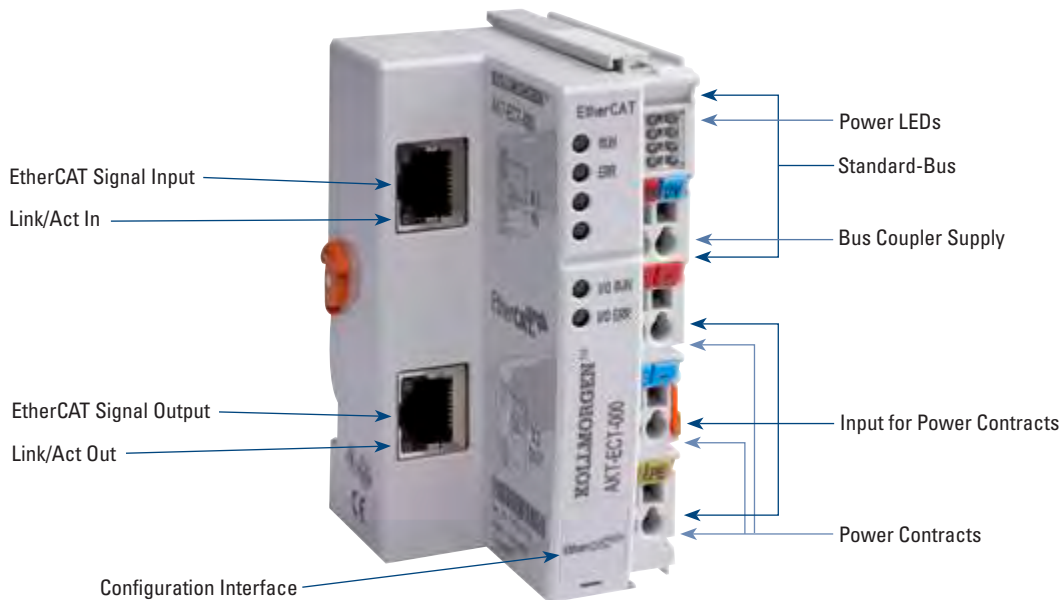

Human Machine Interface (HMI)

Kollmorgen HMI Panels

With Kollmorgen HMI's visualization projects can be scaled for different size screens and performance demands without having to re-write code or learn different tools.

- Full range of sizes 4" to 21" models
- 3 processor levels from ARM to multi-core options
- Wide screen layout gives 30% larger viewing area
- Rugged Aluminum Housing
- Smooth ridgeless IP65 protection class screen for easy cleaning



AKI-CDA Series

4", 7", 10" Touchscreen HMI

Space, price or reliability issues should not limit your application - with Kollmorgen performance panels, any small to medium sized HMI application can have an intuitive graphic interface that'll make operation easier for your customers. These units have no fan or rotating hard drive, which means no moving parts.

AKI-CDB Series

7", 12", 15" Touchscreen HMI

For demanding HMI applications or large projects within traditional industrial or process industry, where complex operating screens filled with objects are required, this operator panel steps up and delivers with mid-range performance hardware that is finely tuned for KVB HMI solutions.

AKI-CDC Series

12", 15", 21" Touchscreen HMI

Ideal for medium to large scale HMI applications that require more power or add-on functionality such as video. Kollmorgen high-performance terminals give you a full, open and expandable HMI, with KVB runtime software, in a robust industrial PC hardware with high connectivity.

HMI Software Tools

Kollmorgen Automation Suite Visualization Builder™ HMI Software

Kollmorgen Automation Suite Visualization Builder operates from within the Kollmorgen Automation Suite integrated development environment making it quick and easy to create your HMI program and transfer it to the panel.

Features include

- Automatic mapping transfers PLC variables to HMI tags avoiding mistakes and saving time.
- Multi-screen navigation
- Trending/Data Logging
- Recipes
- Alarm management
- Drag and Drop programming
- Password Protection



HMI developer environment

Human Machine Interface (HMI)

AKI Series



Specifications	AKI-CDA (Standard)	AKI-CDB (Performance)	AKI-CDC (Premium)
Processor	400 Mhz ARM9	Intel Atom 1.1 Ghz	Intel Core i
Expansion	USB	USB	USB, mini-PCle
OS	Windows CE 6	Windows CE 6	Windows 7 (standard or embedded)
Memory Expansion	SD Card	SD Card	Via USB
Fanless	Yes	Yes	No
RAM	128Mb	1Gb	2Gb or more
LAN	1x 100 Mbit	1x100 Mbit, 1xGbit	2xGbit
HDD Expansion	No	No	Yes
Application Memory	80 Mb	1.4 Gb or more	8Gb - 64 Gb
Audio Output	No	Yes	No
Vector-based Graphics	No	No	Yes
Shadow/Opacity	No	No	Yes
PDF Viewer	No	Basic	Yes
Web Browser	No	Basic	Yes
Fuse	Internal DC fuse, 2.0 AT, 5x20 mm	3.15A slow	10A slow
Operating Temperature	-10 °C to +50 °C	-10 °C to +50 °C	0 °C to +50 °C
Storage Temperature	-20 °C to +70 °C	-20 °C to +70 °C	-20 °C to +70 °C
Relative Operating Humidity	5% - 85% non-condensed	5% - 85% non-condensed	<85% non-condensed
Touch Screen Material	Polyester on glass, resistive. Overlay: Autofex EBA 180L*	Polyester on glass, resistive. Overlay: Autotex F157 or F207*	Polyester on glass, resistive. Overlay: Autotex F157 or F207
Front / Rear Seal	IP 65 / IP 20		
Real Time Clock	Yes (on chip)		

Certificates and Communication	AKI-CDA (Standard)	AKI-CDB (Performance)	AKI-CDC (Premium)
CE Approvals	Noise tested according to EN61000-6-4 emission and EN61000-6-2 immunity		EMC Directive 2004/108/EC Noise tested according to EN61000-6-4 emission and EN61000-6-2 immunity
UL, cUL Approvals (when marked)	UL 1310 Class II	UL 508	UL 508
Serial Ports	9-p;in D-sub contact with RS232 RTS/CTS, chassis-mounted female with std locking screws 4-40 UNC	COM1, COM3: serial Ports for RS232. COM2, COM4: serial Ports for RS422/485	
Ethernet	1 x 10/100/1000 Mbit/s and 1 x 10/100 Mbit/s. Shielded RJ45	1 x 10/100/1000 Base-T (shielded RJ 45) 1 x 10/100 Base-T (shielded RJ 45)	2 x 10/100/1000 Base-T (shielded RJ 45)
USB	1 x USB Host 2.0, max output current 200 mA	3 x USB Host 2.0, max output current 500 mA	4 x USB Host 2.0, max output current 500 mA
Field Buses (expansion modules)	1 x Extension Module Slot for Fieldbus (Optional)		



AKI Series

Electrical and Mechanical Specifications		AKI-CDA-MOD-04T	AKI-CDA-MOD-07T	AKI-CDA-MOD-10T
AKI-CDA	Display	TFT-LCD. 480 x 272 pixels 16.7 million colors (true color) LED backlight	TFT-LCD. 800 x 480 pixels K colors LED backlight	TFT-LCD. 640 x 480 pixels 16.7 million colors (true color) LED backlight
	Screen Size / Active Display, W x H	4.3" / 95.0 x 53.9 mm	7" / 152.4 x 91.4 mm	10.4" / 211.2 x 158.4 mm
	Power Consumption at Rated Voltage	3.6 W	6.0 W	9.6 W
	Front Panel, (W x H x D)	145 x 103 x 7 mm	204 x 143 x 7 mm	280 x 228 x 7 mm
	Cut out Dimensions	128 x 87 mm	189 x 128 mm	262 x 209 mm
	Mounting Depth	43 mm (100 mm including clearance)	43 mm (143 mm including clearance)	44 mm (144 mm including clearance)
	Weight	0.5 kg	0.8 kg	1.5 kg

		AKI-CDB-MOD-07T	AKI-CDB-MOD-12T	AKI-CDB-MOD-15T
AKI-CDB	Display	TFT-LCD. 800 x 480 pixels 262k colors LED backlight	TFT-LCD. 1280 X 800 WXGA 262k colors LED backlight	TFT-LCD. 1280 X 800 WXGA 262k colors LED backlight
	Screen Size / Active Display, W x H	7" / 152.4 x 91.44 mm	12.1" / 261.12 x 163.2 mm	15.4" / 331.2 x 207.0 mm
	Power Consumption at Rated Voltage	14 W	22 W	24 W
	Front Panel, (W x H x D)	204 x 143 x 50 mm	340 x 242,2 x 57mm	410 x 286 x 61mm
	Cut Out Dimensions	189 x 128 mm	324 x 226 mm	394 x 270 mm
	Mounting Depth	43 mm (143 mm including clearance)	50 mm (150 mm including clearance)	54 mm (154 mm including clearance)
	Weight	0.9 kg	2.5 kg	3.6 kg

		AKI-CDC-MOD-12T	AKI-CDC-MOD-15T	AKI-CDC-MOD-21T
AKI-CDC	Display	TFT-LCD. 1280 X 800 WXGA 16 million colors LED backlight	TFT-LCD. 1280 X 800 WXGA 16 million colors LED backlight	TFT-LCD. 1920 X 1080 WXGA 16 million colors LED backlight
	Screen Size / Active Display, W x H	12.1" / 261.12 x 163.2 mm	15.4" / 331.2 x 207.0 mm	21.5" / 6.64 x 268.11 mm
	Power Consumption at Rated Voltage	107 W	114 W	125 W
	Front Panel, (W x H x D)	340 x 242,2 x 79mm	410 x 286 x 83mm	556 x 347 x 87mm
	Cut Out Dimensions	324 x 226 mm	394 x 270 mm	539 x 331 mm
	Mounting Depth	72 mm (172 mm including clearance)	76 mm (176 mm including clearance)	79 mm (179 mm including clearance)
	Weight	4.2 kg	5.4 kg	8.1 kg

I/O Terminals

KOLLMORGEN AUTOMATION SUITE

Advanced Kollmorgen Terminal (AKT)

The Kollmorgen Automation Suite includes an array of I/O options for applications that need more I/O than can be provided by the onboard I/O of the drives or for applications that need specialized functionality such as thermocouple management through I/O. The DIN rail mount IP20 terminals simply slide together and connect to the system's EtherCAT® bus where they are auto-recognized for easy configuration.



I/O

Typical Bus Coupler



EtherCAT® bus coupler

Typical I/O Terminal



Front wiring view



Side label view

Available Motion Bus Coupler Model	
AKT-ECT-000-000	EtherCAT® Bus Coupler
Available Analog Input Terminal Models	
AKT-AN-410-000	4 channel analog input module, 0-10 Vdc
AKT-AN-420-000	4 channel analog input module, 0-20 ma
AKT-AN-810-000	8 channel analog input module, 0-10 Vdc
AKT-AN-820-000	8 channel analog input module, 0-20 ma
AKT-AN-200-000	2 channel thermocouple input module
AKT-AN-400-000	4 channel thermocouple input module
Available Analog Output Terminal Models	
AKT-AT-220-000	2 channel analog output module, 0-20 ma
AKT-AT-410-000	4 channel analog output module, 0-10 Vdc
AKT-AT-420-000	4 channel analog output module, 0-20 ma
AKT-AT-810-000	8 channel analog output module, 0-10 Vdc
AKT-AT-820-000	8 channel analog output module, 0-20 ma
Available Digital Output Terminal Models	
AKT-DT-004-000	4 channel digital output module, 0.5A
AKT-DT-008-000	8 channel digital output module, 0.5A
AKT-DT-2RT-000	2 channel relay output module, 2.0A, N/O

Available Digital Input Terminal Models	
AKT-DN-004-000	4 channel digital input module, 3ms
AKT-DNH-004-000	4 channel digital input module, .2ms
AKT-DN-008-000	8 channel digital input module, 3ms
AKT-DNH-008-000	8 channel digital input module, .2ms
Available Specialty Terminal Models	
AKT-EM-000-000	End module
AKT-IM-000-000	Isolation module
AKT-PS-024-000	Bus feed terminal, 24 Vdc
AKT-PSF-024-000	Bus feed terminal, 24 Vdc, fused
Available Field Bus Coupler Models	
AKT-PRB-000-000	Profibus Bus Coupler
AKT-ENP-000-000	Ethernet/IP Bus Coupler
Stepper Driver	
AKT-SM-L15-000	Stepper Module, 24 Vdc, 1.5 A
AKT-SM-L50-000	Stepper Module, 50 Vdc, 5 A

Kollmorgen Developer Network

Kollmorgen Developer Network (KDN) is the central location for engineers to quickly get support on all Kollmorgen products, interact with and learn from the larger Kollmorgen user community, and receive expert instruction from Kollmorgen Applications Engineers and staff.

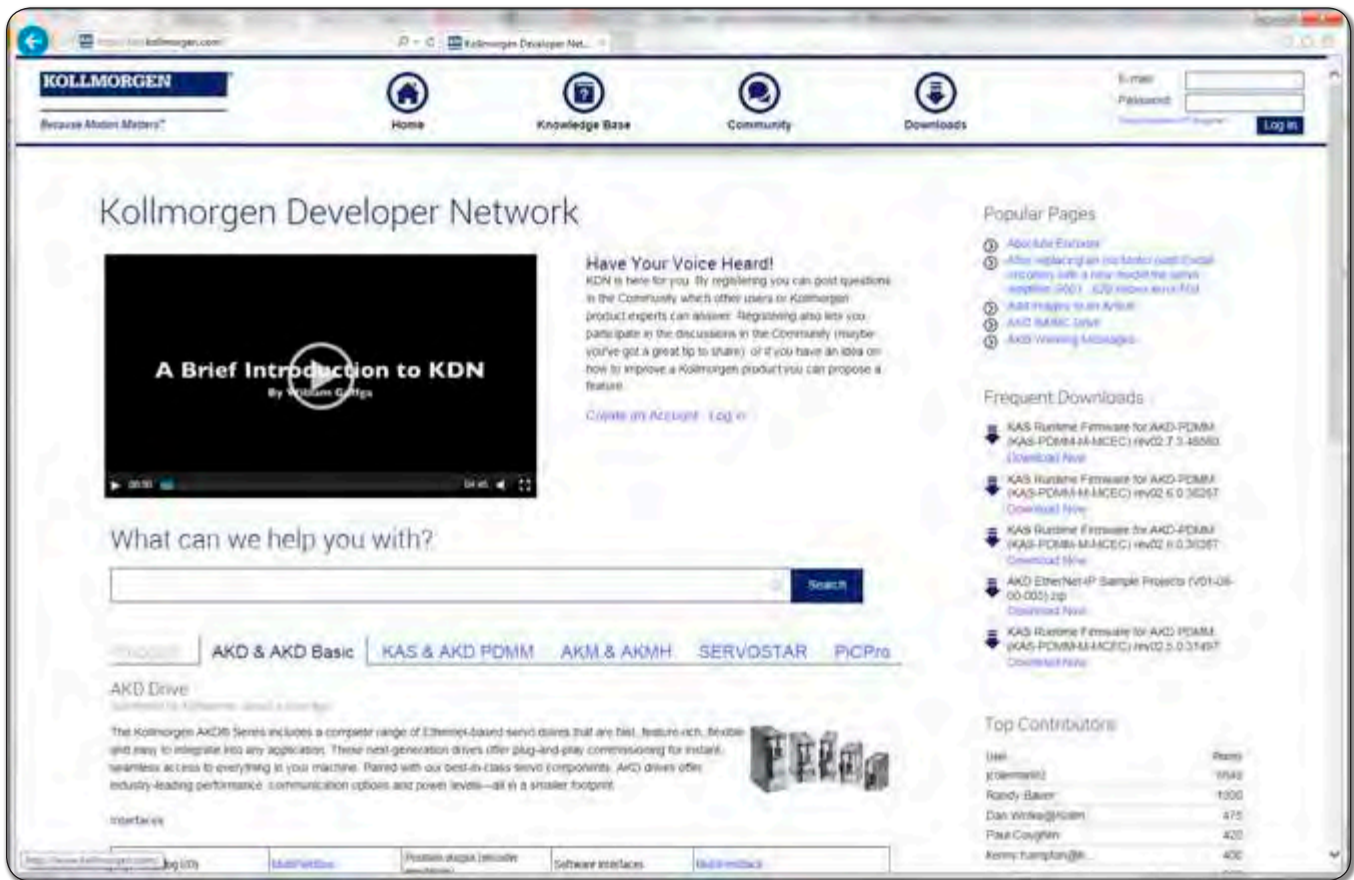

Ask a Question

Ask a question, or search and respond to existing questions. Provide an answer, or vote on the best answer. Leverage the global scope of Kollmorgen to get up to speed quickly.

Start a Discussion

Want to share a best practice, get feedback, or understand how others are solving similar problems? Start a new discussion, or join an active one, to share in the collaborative experience and knowledge of Kollmorgen product developers.

Propose a Feature

Have an idea for a new product, or feature? Submit it here. Customers speak and we listen. We know one size does not fit all. Our product is flexible, but sometimes differentiation requires a collaborative approach.

Latest Downloads

Keep up with our continually improving product, with access to the latest downloads.

AKD® Servo Drive

Our AKD series is a complete range of Ethernet-based servo drives that are fast, feature-rich, flexible and integrate quickly and easily into any application. AKD ensures plug-and-play commissioning for instant, seamless access to everything in your machine. And, no matter what your application demands, AKD offers industry-leading servo performance, communication options, and power levels, all in a smaller footprint.

This robust, technologically advanced family of drives delivers optimized performance when paired with our best-in-class components, producing higher quality results at greater speeds and more uptime. With Kollmorgen servo components, we can help you increase your machine's OEE by 50%.

The Benefits of AKD Servo Drive

- Optimized Performance in Seconds
 - Auto-tuning is one of the best and fastest in the industry
 - Automatically adjusts all gains, including observers
 - Immediate and adaptive response to dynamic loads
 - Precise control of all motor types
 - Compensation for stiff and compliant transmission and couplings
- Greater Throughput and Accuracy
 - Up to 27-bit-resolution feedback yields unmatched precision and excellent repeatability
 - Very fast settling times result from a powerful dual processor system that executes industry-leading and patent pending servo algorithms with high resolution
 - Advanced servo techniques such as high-order observer and bi-quad filters yield industry-leading machine performance
 - Highest bandwidth torque-and-velocity loops. Fastest digital current loop in the market
- Easy-to-use Graphical User Interface (GUI) for Faster Commissioning and Troubleshooting
 - Six-channel real-time software oscilloscope commissions and diagnoses quickly
 - Multi-function Bode Plot allows users to quickly evaluate performance
 - Auto-complete of programmable commands saves looking up parameter names
 - One-click capture and sharing of program plots and parameter settings allow you to send machine performance data instantly
 - Widest range of programming options in the industry
- Flexible and Scalable to Meet any Application
 - 3 to 48 Arms continuous current; 9 to 96 Arms peak
 - Very high power density enables an extremely small package
 - True plug-and-play with all standard Kollmorgen servo motors and actuators
 - Supports a variety of single and multi-turn feedback devices—Smart Feedback Device (SFD), EnDat2.2, 01, BiSS, analog Sine/Cos encoder, incremental encoder, HIPERFACE®, and resolver
 - Tightly integrated Ethernet motion buses without the need to add large hardware: EtherCAT®, SynqNet®, Modbus/TCP, EtherNet/IP, PROFINET, SERCOS III, and CANopen®
 - Scalable programmability from base torque-and-velocity through multi-axis master

Scalable Programmability

SCALABLE PROGRAMMABILITY

Kollmorgen delivers cutting-edge technology and performance with the AKD® servo drive and KAS controls platform. Whether your application requires a single axis or over 100 fully synchronized axes, Kollmorgen’s intuitive software and tools scale to meet your needs. From simple analog torque control to the latest high-performance automation network, the AKD servo drive packs power and flexibility for virtually any application into one of the most compact footprints of any digital servo drive in the industry.

- Patented auto-tuning delivers optimized performance in seconds.
- 1.5MHz current loop and 16KHz velocity loops offers greater bandwidth and performance
Optimized performance in seconds
- Greater throughput and accuracy
- Easy-to-use Graphical User Interface (GUI) for faster commissioning and troubleshooting
- Flexible and scalable to meet any application



Motion Tasking ("P" Option)

- Adds simple point-and-click indexing to base drive
- Provides user with pre-programmed options
- Guides novice user through simplified steps to create indexing moves
- Network connectivity to EtherCAT®, CANopen®, Profinet®, Ethernet/IP™, TCP/IP, SynqNet™ and others
- MODBUS port for communication with HMI

BASIC Programmable 1.5 Axis Drive ("T" Option)

- Adds BASIC programmability to base AKD
- 4KHz programmable interrupt service routines
- Conditional statements, built-in math functions, user functions and subroutines
- Includes 2 high-speed digital inputs
- Same package size as base drive
- Expandable to 31 digital I/O and 4 analog I/O
- Optional integrated SD card for easy backup and drive cloning
- Includes electronic camming functionality

- Controlled by analog torque-and-velocity commands
- Includes electronic gearing via X9 connector
- Includes access to 11 digital I/O and 2 analog I/O on base drive
- Includes 2 high-speed digital inputs
- Expandable to 31 digital I/O and 4 analog I/O

Basic Operation

Single-Axis

RANGE OF KOLLMORGEN AUTOMATION SUITE CAPABILITIES

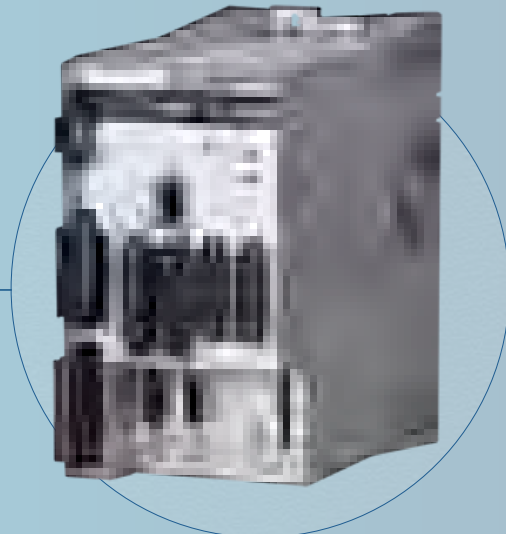
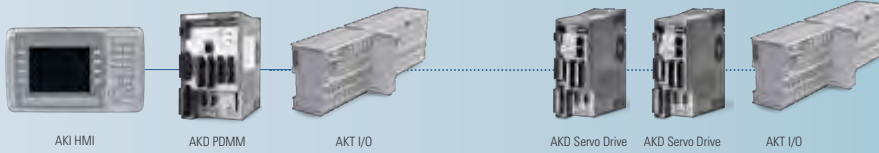

SCALABLE PROGRAMMABILITY

Programmable Drive Multi-Axis Master PDMM ("M" Option)

Seamlessly add additional axes and AKD PDMM serves as a high-performance multi-axis machine controller

- Scalable solution for use as a single-axis drive with integrated programmable automation controller
- Choose from all five IEC 61131-3 languages for soft PLC process programming
- Program motion using your choice of PLCopen for motion or our innovative Pipe Network™
- 4KHz PLC scan rate and EtherCAT® updates
- Complete line of HMI panels with integrated software to simplify GUI development
- Exclusive function blocks, such as "wait," enable your program to act as a scanning or sequential language
- On-board I/O includes 17 digital (with 2 high speed inputs) and 2 analog
- Connects to AKT™ network I/O for nearly unlimited expandability
- SD card for easy backup and system updates
- IoT-enabled integrated webserver for diagnostics and troubleshooting from any computer or mobile device
- Provide true synchronized-path control of up to 16 axes
- Reduce cabinet size and wiring requirements with a single, compact package
- Easily manage remote I/O and the I/O of all attached drives via EtherCAT®
- Use industry standard PLCopen for motion, or step up to Kollmorgen's Pipe Network™ to program sophisticated camming and gearing applications in a matter of minutes



Pipe Network™

Kollmorgen Visual Motion Programming

- Accelerate development by programming tasks in hours that would otherwise take weeks
- Improved coding quality through visual programming and by using pre-built modules that have been thoroughly tested and optimized
- Easy knowledge transfer, replacing pages of complex code with easily understood graphical representations
- Available on PDMM™ controllers

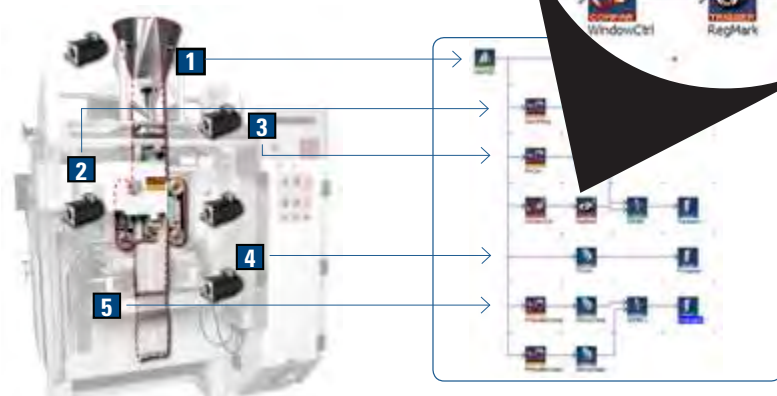

Pipe Network provides a one-to-one translation of a mechanical system into a logical world as shown in the Vertical Form Fill and Seal machine above. Click and build your motion program in minutes, or contact Kollmorgen for examples of common machine architectures to further accelerate your development.

Programming

Multi-Axis Programming

AKD[®] Servo Drive

AKD[®] SERVO DRIVE

The AKD servo drive delivers cutting-edge technology and performance with one of the most compact footprints in the industry. These feature-rich drives provide a solution for nearly any application, from basic torque-and-velocity applications, to indexing, to multi-axis programmable motion with embedded Kollmorgen Automation Suite. The versatile AKD sets the standard for power density and performance.



Cartridge DDR[™] Motors



Frameless Brushless Direct Drive Motors



Housed DDR[™] Motors



AKD-N[™] Decentralized Servo Drive



Direct Drive Linear Motors



Linear Actuators

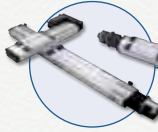

Multi-Axis Precision Tables

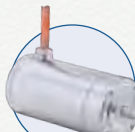

AKMH Hygienic Stainless Steel Motors

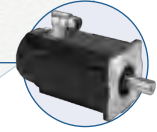

AKM[™] Servo Motors



AKD[®] Servo Drive



Control of motors with AKD[®] PDMM programmable multi-axis master

Best-in-Class Components

AKD works seamlessly with Kollmorgen motors and actuators—well-known for quality, reliability, and performance.



Industry-leading power density

General Specifications

120 / 240 Vac 1 & 3 Phase (85 -265 V)	Continuous Current (Arms)	Peak Current (Arms)	Drive Continuous Output Power Capacity (Watts)	Internal Regen (Watts) (Ohms)		Height mm (in)	Width mm (in)	Depth mm (in)	Depth with Cable Bend Radius mm (in)
AKD-■00306	3	9	1100	0	0	168 (6.61)	57 (2.24)	153 (6.02)	184 (7.24)
AKD-■00606	6	18	2000	0	0	168 (6.61)	57 (2.24)	153 (6.02)	184 (7.24)
AKD-■01206	12	30	4000	100	15	195 (7.68)	76 (2.99)	186 (7.32)	215 (8.46)
AKD-■02406	24	48	8000	200	8	250 (9.84)	100 (3.94)	230 (9.06)	265 (10.43)
240/480 Vac 3 Phase (187-528 V)	Continuous Current (Arms)	Peak Current (Arms)	Drive Continuous Output Power Capacity (Watts)	Internal Regen (Watts) (Ohms)		Height mm (in)	Width mm (in)	Depth mm (in)	Depth with Cable Bend Radius mm (in)
AKD-■00307	3	9	2000	100	33	256 (10.08)	70 (2.76)	186 (7.32)	221 (8.70)
AKD-■00607	6	18	4000	100	33	256 (10.08)	70 (2.76)	186 (7.32)	221 (8.70)
AKD-■01207	12	30	8000	100	33	256 (10.08)	70 (2.76)	186 (7.32)	221 (8.70)
AKD-■02407	24	48	16,000	200	23	310 (12.20)	105 (4.13)	229 (9.02)	264 (10.39)
AKD-■04807	48	96	35,000	—	—	385 (15.16)	185 (7.28)	224 (8.82)	260 (10.23)

For complete AKD servo drive nomenclature, please see page 176.

AKD[®] Servo Drive

Range of Coverage

When you pair the AKD servo drive with any of our Kollmorgen motors or linear actuators, you'll achieve optimized performance. From 3 to 48 Arms continuous current and 9 to 96 Arms peak current, the feature-rich AKD provides a solution for nearly any application.

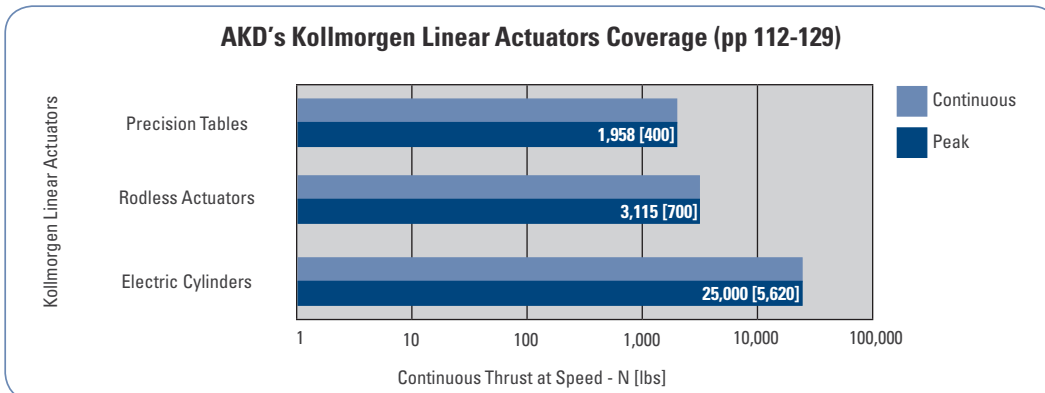
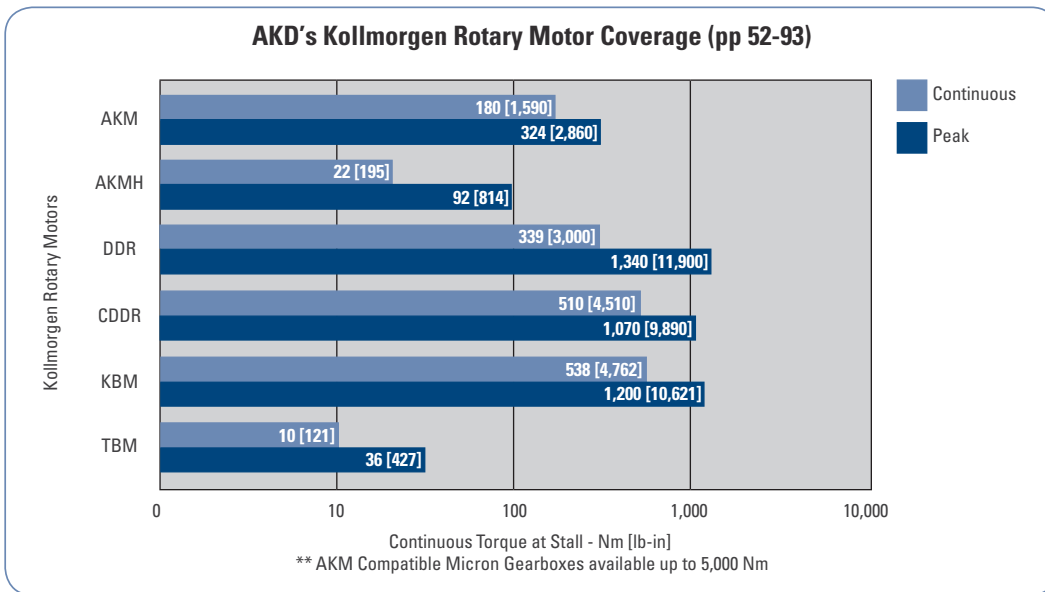
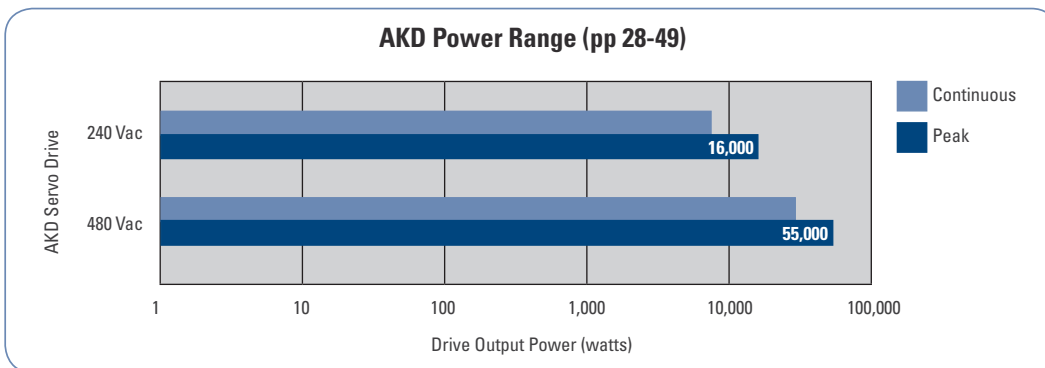

Feedback & I/O

AKD® servo drive is specifically designed with the versatility, communications, and power you need to expand machine performance and increase integration speeds. Motor set-up is plug-and-play and multiple Ethernet connectivity options provide both open and closed protocols. Online troubleshooting and data verification enable faster, bug-proof programming. And a broad power range in a smaller, compact design allows you to use these robust drives with a single interface while experiencing industry-leading, high-performance servo loops.

AKD Specifications		
	Base drive	With I/O expansion
Encoder Output or AUX Encoder Input	2.5 MHz Maximum line frequency	
Feedback	Smart Feedback Device (SFD), EnDat2.2, 01, BiSS, analog Sine/Cos encoder, incremental encoder, HIPERFACE®, and resolver	
Logic supply	24 Vdc	
Digital input (24 Vdc)	8 (1 dedicated to enable)	20 (1 dedicated to enable)
Digital output (24 Vdc)	3 (1 dedicated to fault relay)	13 (1 dedicated to fault relay)
Analog input (+/- 10 Vdc, 16-bit)	1	2
Analog output (+/- 10 Vdc, 16-bit)	1	2
Programmable inputs	7	19
Programmable outputs	2	12
Sink/Source inputs/outputs	Yes	Yes

AKD[®] BASIC Drives

AKD[®] BASIC DRIVES

High Performance Capabilities in an Integrated Drive/Control Solution

Add co-engineering to your toolbox. Save money, simplify your machine and customize performance to meet the specific needs of each customer or application – as needed, today or tomorrow.

Our new Kollmorgen AKD[®] BASIC drives add BASIC-programmable machine and motion control to the superior performance of our AKD drive platform. So engineers can quickly customize performance at the drive level without touching the PLC. In fact, for many applications you can avoid the expense, wiring and cabinet space of a PLC altogether.

Whether you rely on your own engineering expertise or Kollmorgen's, the base and Expanded I/O versions of our AKD BASIC drive give you the unprecedented machine and motion control flexibility in a compact, fully integrated drive package. It's one more example of our co-engineering mission to help you deliver exactly what your customers want – when they want it – in solutions that are more cost-effective to build, simpler in design and faster to market.

AKD BASIC Language Programmable Drive

In addition to the wide selection and key features of our proven AKD, the standard version of our AKD BASIC drive offers:

- **Programmable machine control built into the drive**, so you can engineer perfect axis-level performance without touching the machine controller. In fact, AKD BASIC can eliminate the need for a PLC in single and 1.5 axis applications – reducing wiring requirements, panel space, design complexity and cost.
- **High performance motion control built into the drive**, enabling increased speed for more complex moves in a simpler design with reduced wiring.
- **BASIC Language programming**, providing simple program flow control in a solution that's easy to learn, quick to master and universally accepted.
- **An integrated development environment**, allowing single-point programming, de-bugging, commissioning, tuning and management of your AKD BASIC drive from within AKD WorkBench. Our BASIC editor provides innovative features that speed development time and reduce coding errors.
- **Source code lockout with password protection**, freeing you to differentiate your product with drive-level control while safeguarding your intellectual property.

I/O Capabilities	Base Version	Expanded I/O Version
Digital Inputs	8	20
Digital Outputs	3	13
Analog Inputs	1	2
Analog Outputs	1	2

Expanded I/O AKD BASIC Programmable Drive

Building on the features of the AKD BASIC drive, we also offer an expanded I/O version that adds:

- **A total of 20 digital inputs, 13 digital outputs, 2 analog inputs and 2 analog outputs**, reducing or eliminating the need for remote I/O and its associated installation and wiring costs.
- **An SD memory card slot** for loading, and restoring programs and parameters, without the need for a PC.



Development Tools that Speed Programming and Improve Quality

Co-engineering is a powerful tool. To make it easy for you to provide better solutions for your customers, we provide an innovative BASIC programming environment within Kollmorgen WorkBench. So there's only one software package to use for all of your drive setup, configuration, tuning and management tasks in addition to motion and machine control programming.

Pre-built code templates give your application a head-start, while automatic formatting, highlighting and other ease-of-use features increase programming speed and accuracy. Complete access to all programming capabilities and drive features within a single environment helps speed your development of complete, optimally engineered solutions.

Novice users will enjoy a short ramp-up time to productive coding, while experienced users will discover well-designed tools that take their programming skills to new levels of speed and quality.

- 1 Integrated axis setup
- 2 Code snippets simplify formatting
- 3 Auto-complete helps speed coding and reduce errors
- 4 Automatic color coding makes it easy to distinguish comments, parameters, print statements and other types of code
- 5 Full debugger accelerates development
- 6 Packaged program console provides instant program status
- 7 Menu-driven navigation provides intuitive look and feel
- 8 Window pinning maximizes workspace

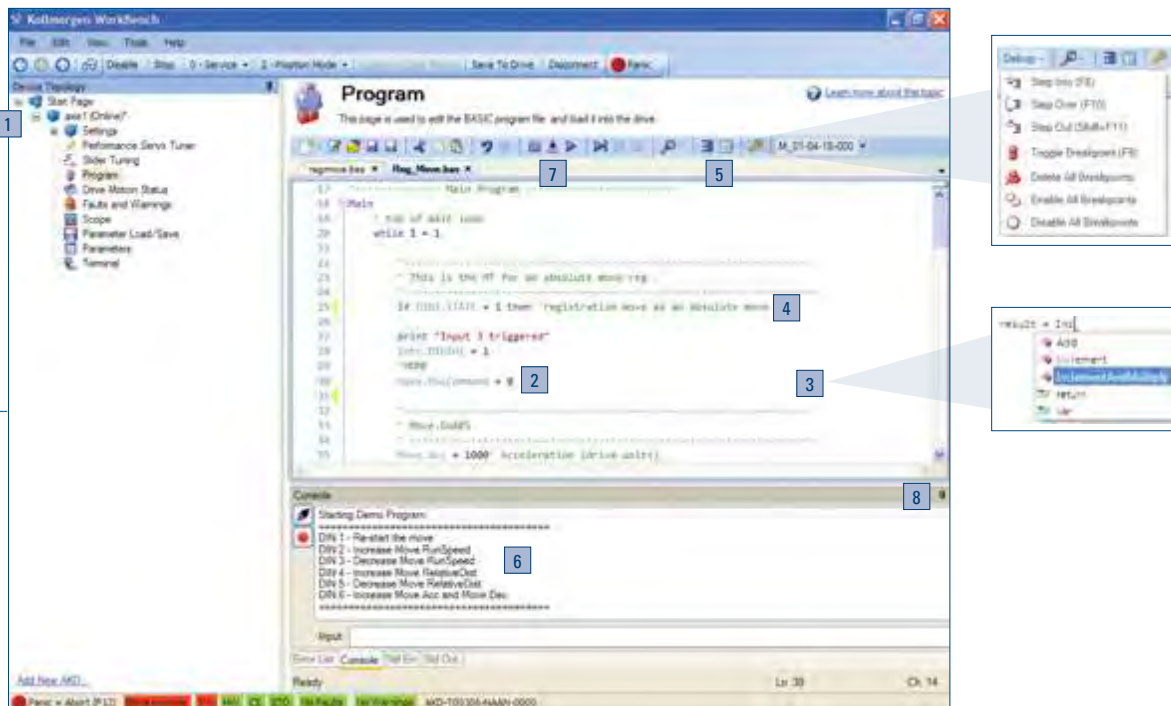

AKD[®] PDMM[™] Drive-Resident Controller

AKD[®] PDMM[™] DRIVE-RESIDENT CONTROLLER

Build Simpler and Better with Drive-Resident Machine and Motion Control

Extend your design options. Control as many as eight axes or more without the need for a PLC or PAC. Reduce cabinet space and wiring requirements. Program perfect machine and motion control for any project using a single, fully integrated programming environment. Build a better machine at a lower cost.

Our new addition to the AKD[®] drive family combines one servo axis, a master controller that supports multiple additional axes, and the full automation capability of Kollmorgen Automation Suite[™]—all in a single, compact package.

Welcome to the AKD PDMM[™] programmable drive, multi-axis master.

Performance Specifications

120/240 Vac 1- and 3-Phase	Continuous Current (Arms)	Peak Current (Arms)	H (mm/inches)	W (mm/inches)	D (mm/inches)
AKD-M00306-MCEC-0000	3	9	168 / 6.61	89 / 3.50	156 / 6.14
AKD-M00606-MCEC-0000	6	18	168 / 6.61	89 / 3.50	156 / 6.14
AKD-M01206-MCEC-0000	12	30	196 / 7.72	107 / 4.22	187 / 7.36
AKD-M02406-MCEC-0000	24	48	248 / 9.76	96 / 3.78	228 / 8.97

240/400/480 Vac 3-Phase	Continuous Current (Arms)	Peak Current (Arms)	H (mm/inches)	W (mm/inches)	D (mm/inches)
AKD-M00307-MCEC-0000	3	9	256 / 10.08	99 / 3.90	185 / 7.28
AKD-M00607-MCEC-0000	6	18	256 / 10.08	99 / 3.90	185 / 7.28
AKD-M01207-MCEC-0000	12	30	256 / 10.08	99 / 3.90	185 / 7.28
AKD-M02407-MCEC-0000	24	48	306	99 / 3.90	228 / 8.98
AKD-M04807-MCEC-0000	48	96	385	185 / 7.28	225 / 8.85

Features

- Kollmorgen Automation Suite[™] provides fully integrated programming, testing, setup and commissioning
- Embedded web server utility simplifies service
- Control 32 axes or more* while reducing machine footprint
 - EtherCAT[®] multi-axis master motion controller integrated with a standard AKD[™] drive axis
 - Full IEC61131-3 soft PLC for machine control, with support for all 5 programming languages
 - Choice of PLCopen for motion or Pipe Network[™] for programming motion control
 - 32 KB non-volatile memory stores machine data to eliminate scrap upon restart after power failure
 - SD Card slot simplifies backup and commissioning, with no PC required
 - On-board I/O includes 13 digital inputs, 4 digital outputs, 1 analog input, 1 analog output (expandable with AKT series of remote I/O)
- Works with Kollmorgen Visualization Builder for programming AKI human-machine interface panels



*Maximum axis count depends on motion/automation complexity and performance (8 axes nominal based on medium complexity at 4 kHz network update rate)

A Single, Scalable Development Suite

Kollmorgen Automation Suite™ simplifies and accelerates development through a unified system of software, hardware, and collaborative co-engineering. This scalable solution provides a fully integrated development environment for any application, whether you're programming a single axis of motion, a multi-axis AKD PDMM™ system, or a PCMM-based system up to 64 axes or more. Kollmorgen Automation Suite has been proven to:

- Improve product throughput by up to 25% with industry-leading motion bandwidth
- Reduce scrap by up to 50% with world-class servo accuracy, seamless power-failure recovery and highly dynamic changeovers
- Increase precision for better quality, reduced waste and less downtime using EtherCAT®—the field bus with motion bus performance
- Enable more adaptable, sustainable and innovative machines that measurably improve marketability and profitability

A Single Family of Servo Drives

Kollmorgen AKD™ servo drives deliver cutting-edge performance in a compact footprint. From basic torque-and-velocity applications, to indexing, to multi-axis programmable motion, these feature-rich drives offer:

- Plug-and-play compatibility with your servo motor
- All the advantages of Kollmorgen's breadth of motor platforms including AKM™, CDDR™, and other direct-drive technologies
- The fastest velocity and position loop updates
- Full-frequency auto-tuning for perfect motion across the performance spectrum
- Real-time feedback from a wide variety of devices

Our Best Drive and Automation Solution in a Single Package

The new AKD PDMM programmable drive, multi-axis master combines our AKD drive platform with the full feature set of Kollmorgen Automation Suite in a single package—providing complete machine and motion control for up to eight axes or more.

You need only one development suite and one drive family for all your projects. And you can rely on one source for all the motion components and co-engineering expertise you need to build a better machine.

With AKD PDMM, the best in machine engineering has never been easier, faster or more cost-effective.



To learn more about the programmability of AKD drives, please refer to the Kollmorgen Automation Suite section.

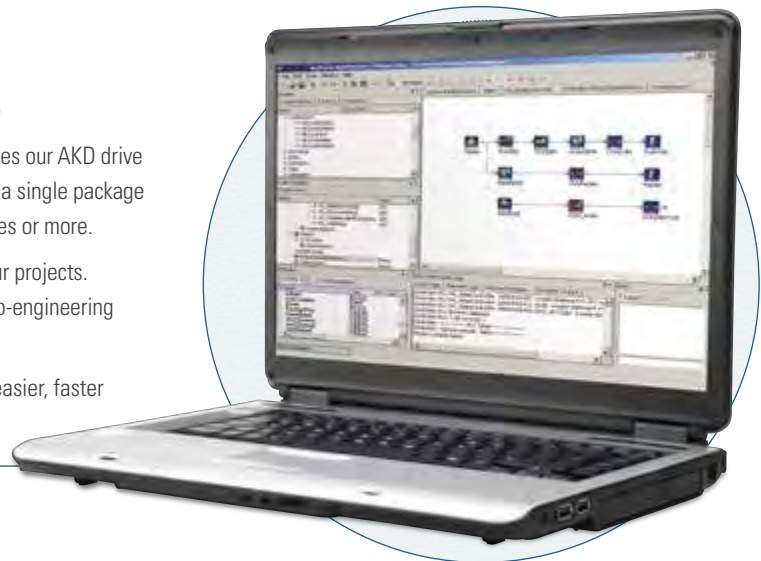

AKD[®] Servo Drive

AKD[®] SERVO DRIVE

Ethernet Connectivity

- Ethernet-based AKD servo drive provides the user with multiple bus choices
- EtherCAT[®] (DSP402 protocol), Modbus/TCP, SynqNet[®], EtherNet/IP, PROFINET, SERCOS III, and CANopen[®]
- No option cards are required



Industrial Design

- Rugged circuit design and compact enclosure for space-saving, modern appearance – minimizes electrical noise emission and susceptibility
- Full fault protection
- UL, cUL listed, and CE
- No external line filters needed (480 Vac units) for CE & UL compliance
- Removable screw terminal connectors for easy connections
- DC Bus sharing



Safe-Torque-Off (STO)

(IEC 61800 SIL2)

- Switches off the power stage to ensure personnel safety and prevents an unintended restart of the drive, even in fault condition
- Allows logic and communication to remain on during power stage shut down

Plug-and-Play with Kollmorgen Motors and Actuators

- Electronic motor nameplates allow parameters to automatically load for fast commissioning
- Motion in seconds
- Custom motor parameters easily entered

Internal Regenerative Braking Resistor

(All powers except 120/240 Vac 3 Arms and 6 Arms)

- Simplifies system components
- Saves overhead of managing external regeneration when internal regeneration is sufficient

I/O (Base Drive)

- 8 digital inputs (1 dedicated to enable)
- 2 high-speed digital inputs (maximum time delay of 1.0 μs)
- 3 digital outputs (1 dedicated to fault relay)
- 1 analog input - 16 bit
- 1 analog output - 16 bit



Performance Servo Tuner (PST)

- Exclusive patent pending auto-tuner reaches optimized set-up in seconds
- Handles inertia mismatches up to 1000:1
- Industry leading bandwidth under compliant and stiff load conditions, no matter the mechanical bandwidth of the machine



AKD 120/240 Vac Connector Layout

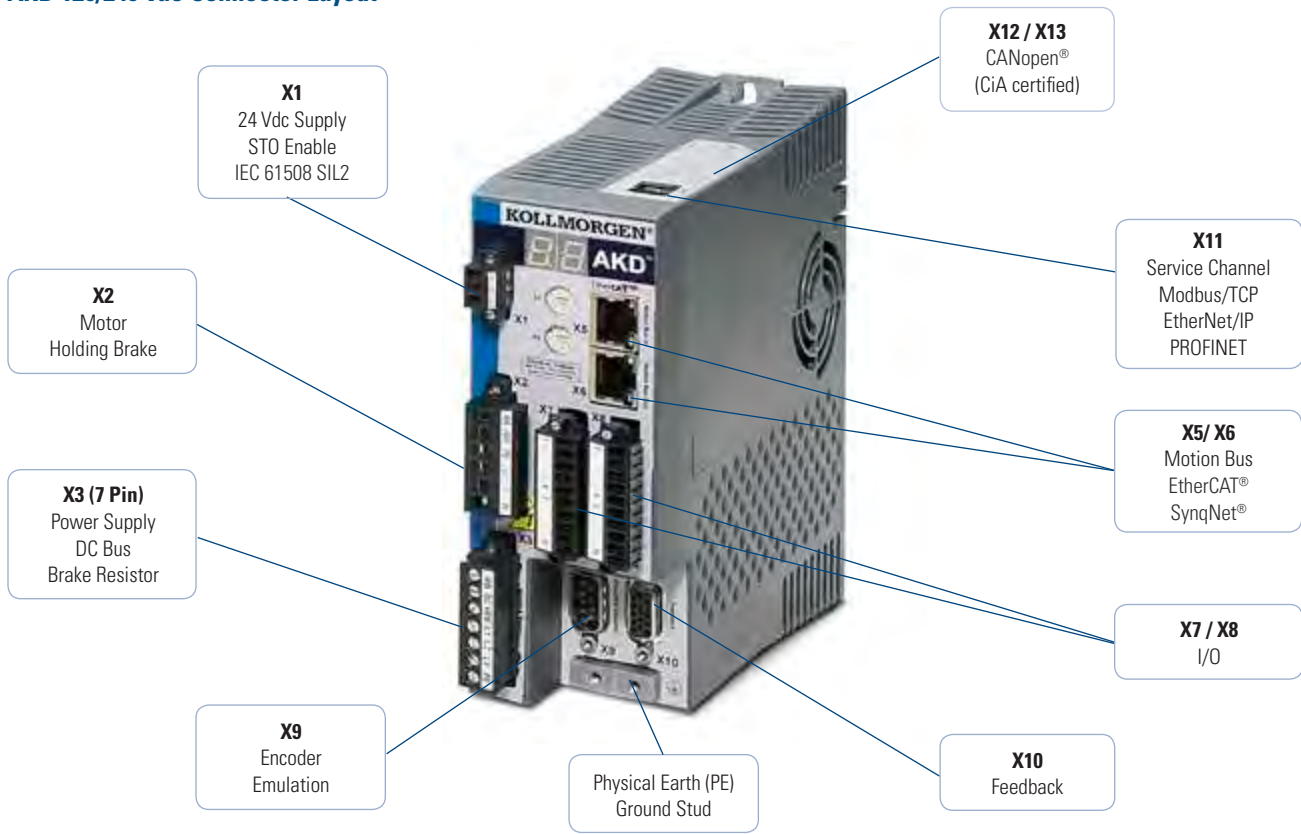

AKD 240/480 Vac Connector Layout

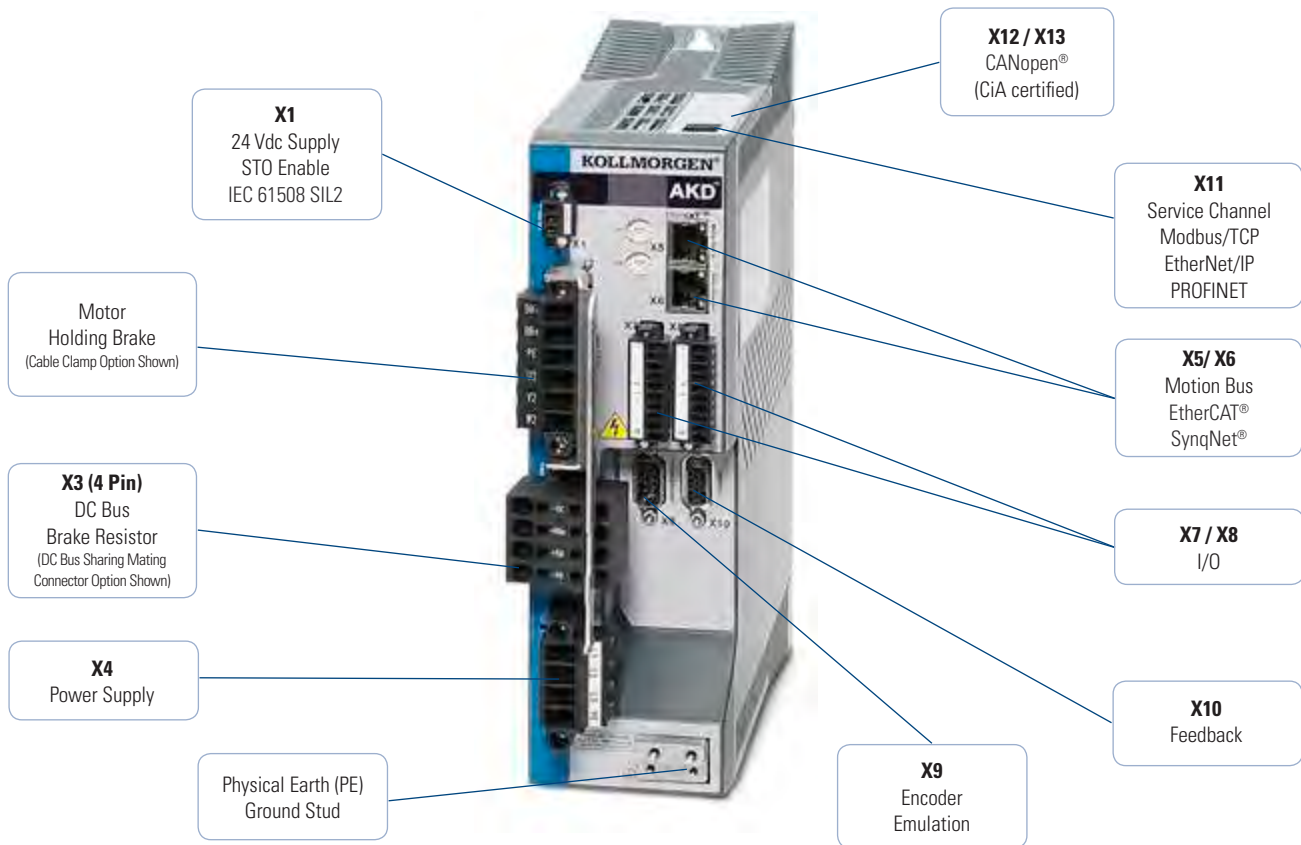

AKD-N™ Decentralized Servo Drive

The new decentralized AKD-N servo drives from Kollmorgen can be placed in the immediate vicinity of the motor thanks to its robust, compact construction and protection class IP67. Plug-in connections, excellent motor compatibility and high degree of integrated functionality: With the decentralized AKD-N servo drives, you can develop drive and automation architectures that are easily comprehensible, and integrate with the central AKD servo drives. Using EtherCAT® as a system bus, we reduce complexity further since the AKD-N can collect I/O signals on the axis and pass them on in bundled form.

Improved Overall Equipment Effectiveness (OEE)

With AKD-N you increase the effectiveness beyond the entire life cycle of your machine (OEE, Overall Equipment Effectiveness). The design configuration and simple connection technology decrease the time for assembly, installation, and start-up. During the operating phase, the AKD-N plays a valuable part in energy savings due to the integrated DC connection. Further advantages in production are faster cleaning cycles thanks to a higher protection class as well as fewer cables in combination with a space-saving switch cabinet superstructure. Moreover, the assembly and connection technology increases the availability – and thereby productivity – because maintenance and service tasks are completed faster.

The Advantages of Decentralized Servo Drives

- | | |
|--|---|
| <ul style="list-style-type: none"> • Reduced costs | <ul style="list-style-type: none"> • Reduced cabling because DC and network, power supply, I/O level as well as safety (STO) run in one cable • Faster and simple assembly, even without special knowledge, through ready-made and tested cables • Lack of derating enables smaller motor and servo drive combinations compared to integrated system with the same output power |
| <ul style="list-style-type: none"> • Compacter machines | <ul style="list-style-type: none"> • Smaller and therefore more easily integrated switch cabinets • Servo drives in the immediate vicinity of the motor • Robust construction in Protection class IP67 makes protective enclosures superfluous |
| <ul style="list-style-type: none"> • Faster startup | <ul style="list-style-type: none"> • Plug connectors in IP67 for connection without tools • At only eleven millimeters, the thin hybrid cable can be laid in a space-saving manner – even in tight machine corners, thanks to a small bending radius • Simple connection of I/O systems or networks directly to the drive • Parameterization with the tools of the Kollmorgen WorkBench |
| <ul style="list-style-type: none"> • Higher machine effectiveness (OEE) | <ul style="list-style-type: none"> • Design supports fast and effective cleaning • High operating safety through robust construction • Precision through digital feedback • Everything at a glance: Status display on servo drive |
| <ul style="list-style-type: none"> • More flexibility in machine design | <ul style="list-style-type: none"> • Compatible with all motors from Kollmorgen with single- or dual-cable connection • Simple combination of central and decentralized controllers within the comprehensive AKD family • Faster modification and upgrade options through linear topology as well as I/O and network interfaces at the axis |

AKD-N Decentralized Servo Drives

Next Gen Machine Design Now

Next gen design requires the perfect interplay of standardized drive and automation components. Selection of a functional, freely scalable solution ultimately ensures the highest degree of design freedom in building machines that operate efficiently without complexity.

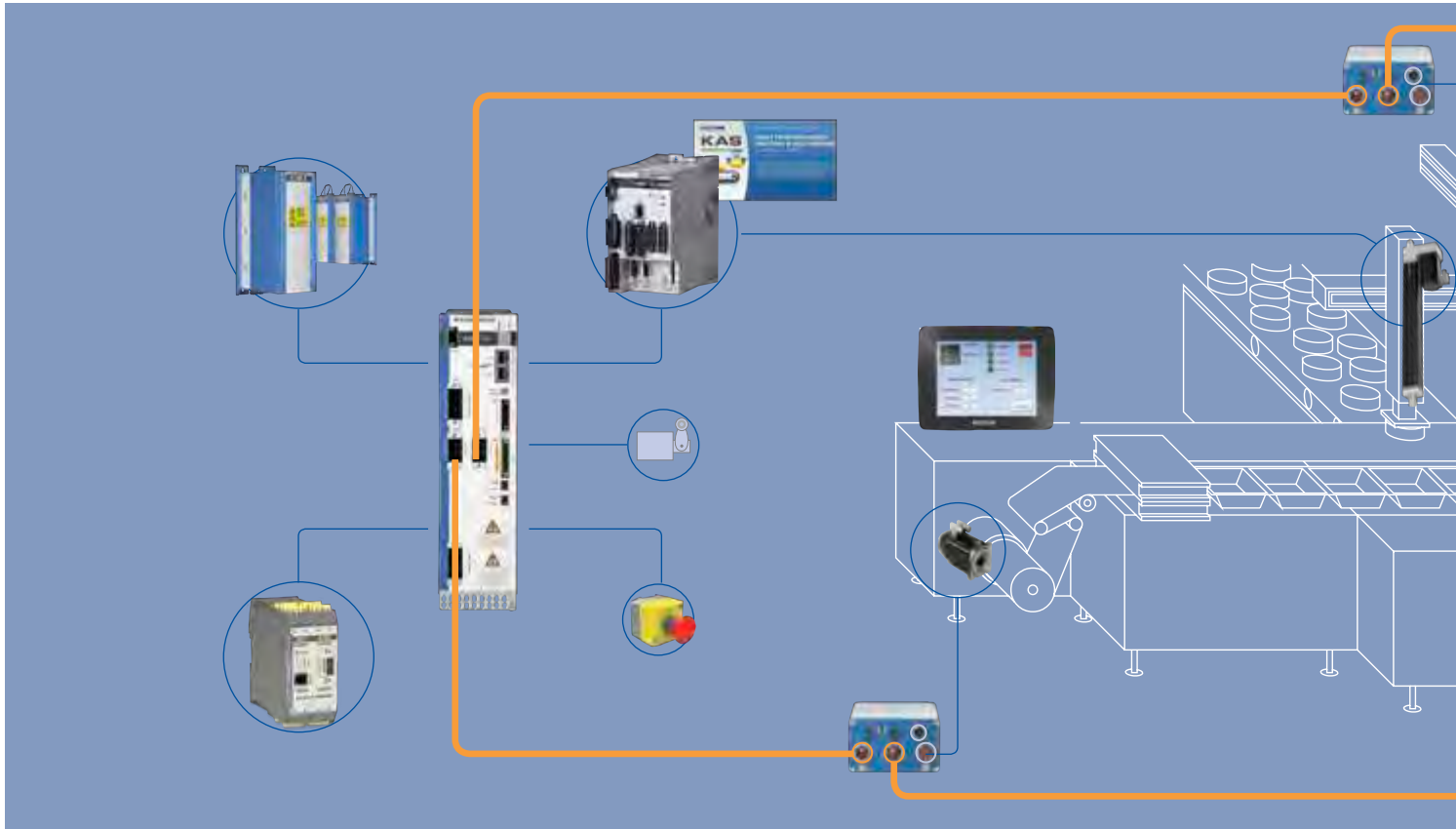

AKD - N DECENTRALIZED SERVO DRIVES

Kollmorgen Automation Suite



- Scalable automation solution for drive-dominant applications
- Graphic motion programming
- Compatible with IEC 61131-3 and PLCopen Motion Control

AKD-C Central Power Supply Module



- Power supply for up to 16 AKD-N
- Complete integration in the AKD family
- EtherCAT® Network
- 2 STO inputs SIL 2 / PLd
- 1 each digital input and output, 1 relay output

AKD-N Distributed Servo Amplifier



- Less cabling through single-cable solution
- Fast installation, simple assembly and connection
- IP65/IP67, UL design 4x
- Options: local EtherCAT® interface or local STO (SIL2/PLd), connection for feedback systems

AKD PDMM



- High-performance servo amplifier with integrated multi-axis master controller
- Functional scope of the Kollmorgen Automation Suite
- 3 in 1: Servo amplifier, PLC and motion controller
- EtherCAT®, Profinet, Ethernet/IP and Modbus TCP standard

KCM Condenser Modules



- Reduces the energy costs and prevents downtime
- Simple Implementation
- No harmonics in the power cables
- Scalable capacity

KSM safety controller



- Machine and motion safety in one device
- More than 200 verified safety functions
- Flexible – scalable from 1 to 12 secure axes
- High safety standard – Safety Level SIL 3 / PLd

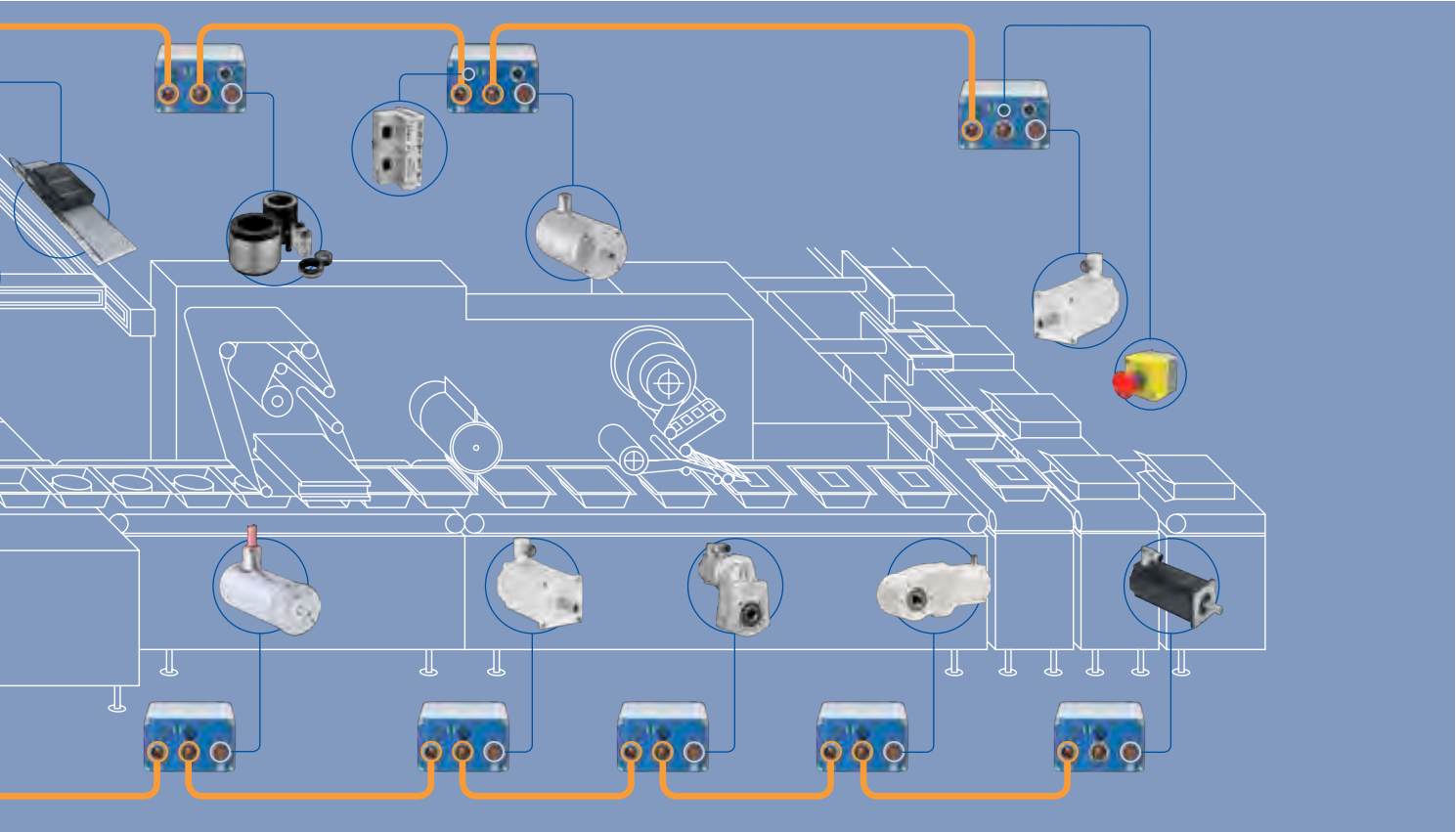

AKM Servo Motors

- High torque density
- High precision and dynamics
- Produced in Europe, US and Asia regions



AKM Washdown Servo Motors

- Applications with regular cleaning
- Housing coating is Ecolab-certified



AKM Washdown Food Servo Motors

- For use in the food and beverage industry
- Protection class IP67, FDA compliant



AKMH Stainless Steel Motors

- For the highest hygienic requirements
- Protection class IP69K
- Fulfills EHEDG directive



AKM Food-Grade Gearmotor

- The highest hygienic requirements
- High efficiency
- Single-cable connection



Cartridge DDR Rotary Direct Drives

- Direct load coupling without gears or belts
- High precision, low noise generation



KBM Direct Drives with No Housing

- Low weight, exceptionally compact
- Modular system

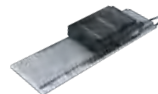

DDL Linear Motor

- High power density
- Large dynamics (>10g)
- Patented anti-cogging design

AKD-N Decentralized Servo Drives

Our Way of Making Machines Simpler and More Efficient

AKD - N DECENTRALIZED SERVO DRIVES

- Advantage: Lower machine complexity
- Advantage: Greater freedom of design
- Advantage: Higher OEE (Overall Equipment Effectiveness)



■ Decentralized solution reduces effort and costs for switch cabinet

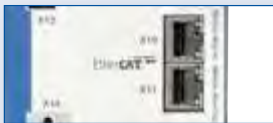

■ MotionBus (EtherCAT®) for connection to automation systems

■ Connection of external additional components

■ A single AKD-C supplies up to 16 AKD-N

■ Startup with the Kollmorgen WorkBench

■ Status LED for simple diagnosis

■ Simple connection of local I/O

■ Options like tertiary network and local STO offer maximal flexibility

■ IP67 / UL type 4x housing reduces cleaning times and makes special protective enclosures redundant.

■ Simple and fast attachment

■ Compatible with all motors from Kollmorgen

■ A single cable with 11 mm diameter for DC bus, electrical supply, EtherCAT® network and STO reduces cabling outlay, increases the reliability and enables flexible machine design

■ Hybrid motor cable for simplified cabling, faster installation and higher reliability

Why Lay 1220 ft. of Cable when 138 ft. Will Suffice?

Imagine your machine includes eight axes each with a distance of three meters. The switch cabinet is 5 meters away and on each axis there is also a switch. With this thoroughly realistic example, that equates to a total of 1220 feet of cable – with our AKD-N it would have been 138 feet. The decentralized servo technology of the AKD-N saves 1082 feet here! That is cable that does not have to be purchased or laid and which does not require any space in the machine construction. We find that these are very good grounds for starting the comparison. We combine the AKD-N servo controllers and their power supply modules with pre-assembled and tested system cables – it doesn't get much simpler than this.

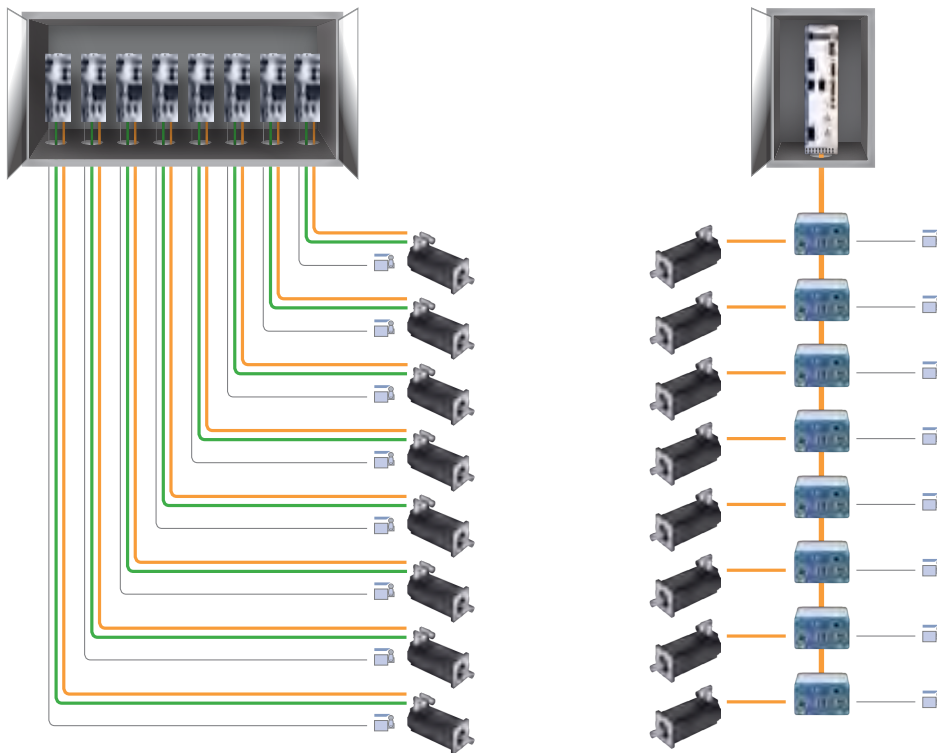

Regardless of which Motor: Plug and Play

Our AKD-N decentralized servo controllers work optimally with every motor. Within our Kollmorgen system, you can also thoroughly use all advantages of the single-cable connection technology individually.

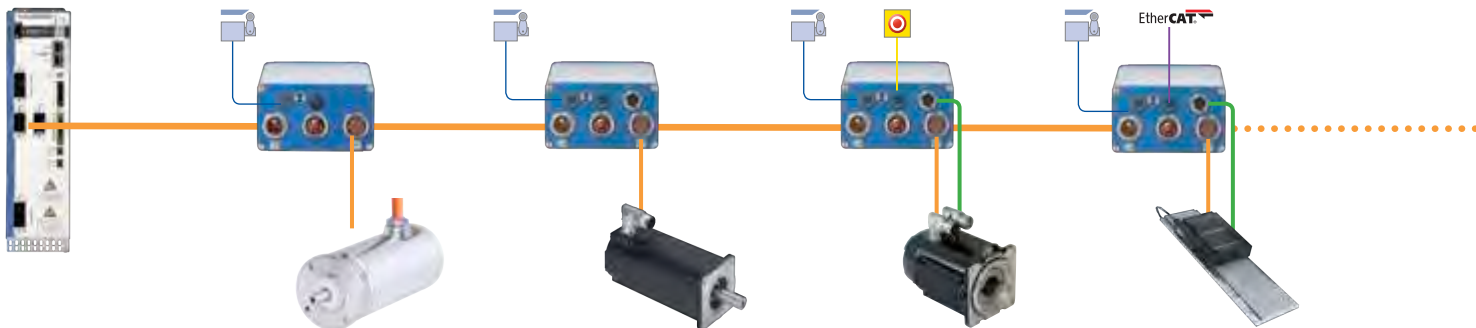

AKD-N Decentralized Servo Drives

Technical Data and Topology

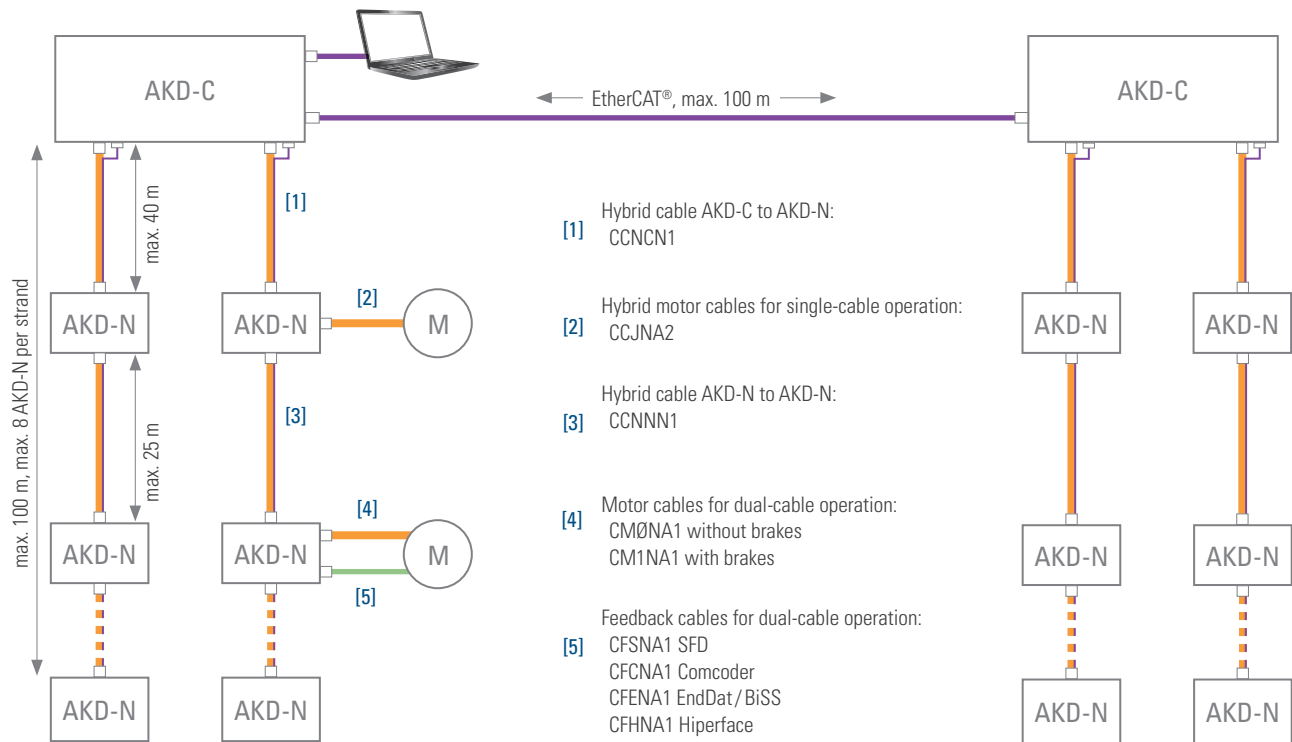

AKD-N Decentralized Servo Drives

Continuous current	3 A, 6 A
Peak current	9 A, 18 A
Continuous input power	1.5 kVA, 3 kVA
Protection class	IP67
Digital inputs/outputs	3 digital inputs/ 1 digital output
Safety function	STO SIL 2 (only AKD-N-DS)
Feedback systems Dual-cable (not with -DB)	SFD (digital resolver), BiSS-C, Comcoder, hall sensor, Endat 2.1 and 2.2, Hiperface, Hiperface DSL
Feedback systems Single-cable	SFD3 (digital resolver) and Hiperface DSL
Communication	EtherCAT®
Dimensions (W x H x D)	Housing: 130 x 75 x 201 (mm) With plugs 130 x 75 x 247 (mm)

AKD-C Power Supply Module

Line voltage	400 / 480 V
Overall performance	10 kW
Intermediate circuit voltage	560 / 680 V DC
Output current	17 A (peak 34 A)
Protection class	IP20
Output strands	2, for up to 8 AKD-N apiece
Safety function	one STO Enable and STO Status apiece for each strand, SIL 2
Digital inputs/outputs	1 input, 1 output, 1 relay output
Communication	EtherCAT®, TCP/IP service interface
Dimensions (W x H x D)	Housing (Front) 80 x 260 x 198 (mm) Installation dimension with plugs 80 x 329 x 231 (mm)

For complete AKD-N and AKD-C nomenclature, please see page 176.

Connections and Controls

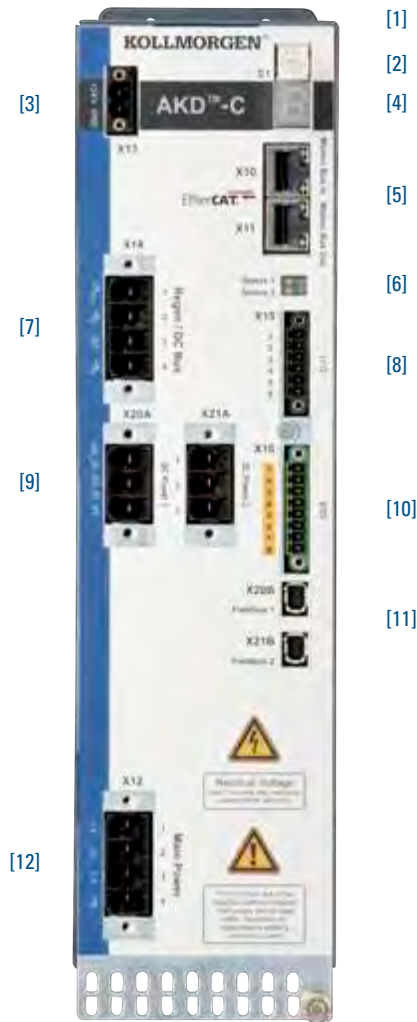

- [1] Network connection for service PC (TCP/IP) (on the top)
- [2] Setting the IP address
- [3] 24 V DC power supply
- [4] Error and status displays
- [5] Motion Bus I/O connections (EtherCAT®)
- [6] Status display of the local network
- [7] Connection for external brake resistor and KCM buffer module
- [8] I/O (1 each digital input and output, 1 relay output)
- [9] DC outputs for connection of up to eight decentralized AKD-N servo drives apiece
- [10] STO input, STO status output (one each per strand),
- [11] Local network for communication with AKD-N
- [12] Power connection 400 V / 480 V AC

Connection Options for AKD-N

AKD-N-	Single-cable technology	Separate feedback	Digital I/O	Tertiary network	Local STO
DB		—		—	—
DF					—
DS				—	

AKD-N-DB Decentralized Servo Drives

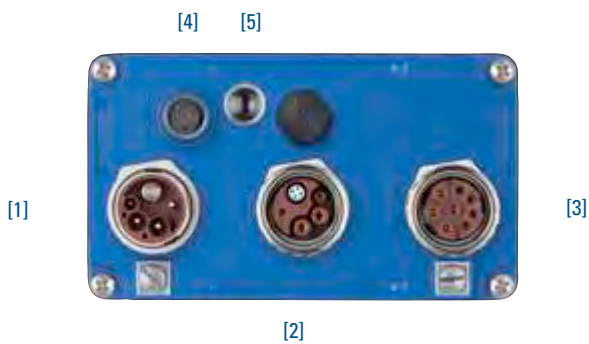

- [1] [2] Connections for hybrid cable
- [3] Motor connection
- [4] 3 digital inputs, 1 digital outputs
- [5] Status/error display with LED

AKD-N-DS, -DF Decentralized Servo Drives

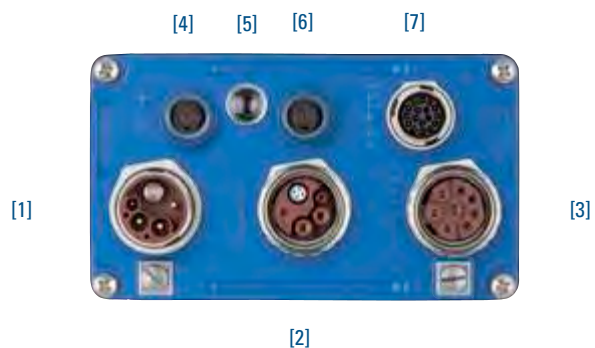

- [1] [2] Connections for hybrid cable
- [3] Motor connection
- [4] 3 digital inputs, 1 digital outputs
- [5] Status/error display with LED
- [6] STO connection (-DS) / Tertiary network (-DF)
- [7] Connection for feedback with dual-cable technology

Kollmorgen Workbench

K O L L M O R G E N W O R K B E N C H

Our simple Graphical User Interface (GUI), Kollmorgen WorkBench, is designed to expedite and streamline the user's experience with the AKD® servo drive. From easy application selection and reduced math, to a sleek six-channel scope; the user interface is extremely easy to use. Kollmorgen WorkBench supports intuitive access to the exclusive Performance Servo Tuner (PST) available inside AKD. The patent pending PST makes auto-tuning the AKD high-performance servo drive with world-class Kollmorgen motors very simple.

User-Friendly Environment

Logical flow, colorful icons and easy access simplify interactions with the AKD servo drive. The folder structure allows for instant identification and easy navigation.



Sleek Six-Channel "Real-Time" Software Oscilloscope

The easy-to-use AKD servo drive interface has a sleek digital oscilloscope that provides a comfortable environment for users to monitor performance. There are multiple options to share data in the format you prefer at the click of a button.

- Save as an image
- Load to an e-mail
- Print

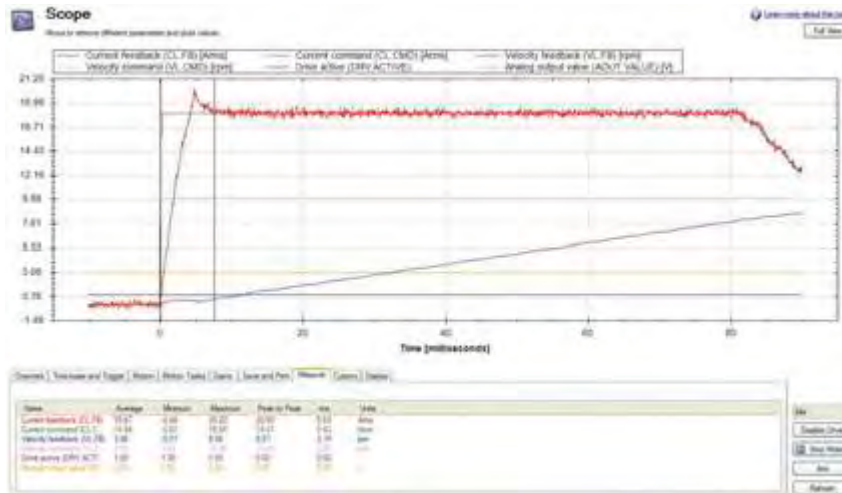

Application Selection

Simplifies set-up by allowing use of machine or application-based units. Nip roller and rack and pinion set-ups shown.

Nip Roller Application Selection

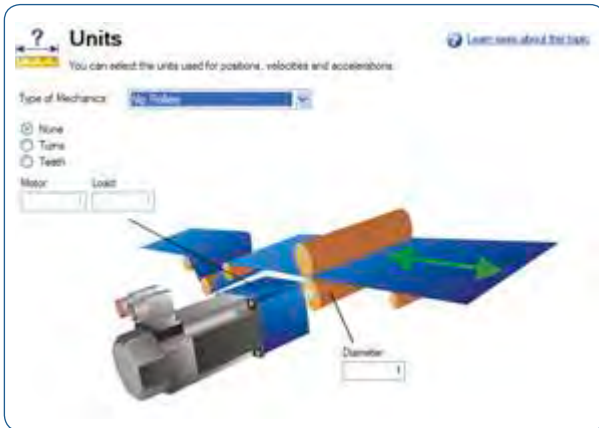

Rack and Pinion Application Selection

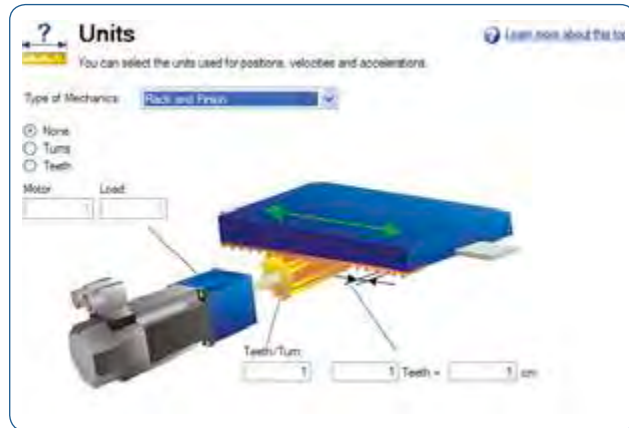

Data-Sharing

The ease-of-sharing continues in the parameters window. Kollmorgen WorkBench provides the user the easy options of printing or emailing the parameter values at the click of a button.

Full Name	Value	Units	Parameter	Read/Write
Active Disable				
Deceleration during active disable	3000.000	rpm/s	AD_DEC	read-write
Time-out	1000	ms	AD_DISTO	read-write
Stall	0	ms	AD_STATE	read-only
Velocity window	120.000	rpm	AD_VELTHRESH	read-write
Time delay after velocity window	5	ms	AD_VELTHRESHTM	read-write
Analog Input				
Analog input low pass filter cutoff freq.	5.000.000	Hz	AIN_CUTOFF	read-write
Analog input signal deadband	0.000	V	AIN_DEADBAND	read-write
Analog input mode	0 - Inactive		AIN_MODE	read-write
Analog input offset	0.000	V	AIN_OFFSET	read-write
Analog input signal	0.000	V	AIN_VALUE	read-only
Analog Input/Output				
Analog input torque scale	0.001	A/V	AIO_FSCALE	read-write
Analog input velocity scale	0.060	rpm/V	AIO_VSCALE	read-write
Analog Output				
Analog output mode	0 - User Variable		AOUT_MODE	read-write
Analog output value	0.000	V	AOUT_VALUE	read-write
Mode				
Current Loop				
Current command	0.000	A	CLCMD	read-only
Current command - user	0.000	A	CLCMDU	read-write
Current command - D component	0.000	A	CLDCMD	read-only
Current command - user D component	0.000	A	CLDCMDU	read-write

Servo Motors

When you need precise position control, choose from Kollmorgen's broad portfolio of servo system components. Our unparalleled product line breadth provides great flexibility for any application. Whether it's any combination of motors and drives, cables, controller, electric cylinders or gearboxes, all components are plug-and-play for easy, seamless integration. These best-in-class servo systems can be matched with single-axis or multi-axis motion controllers for a system solution that's precise, reliable and durable.

The Advantages of AKM Servo Motors

- | | |
|--|--|
| <ul style="list-style-type: none"> • With the same size, the AKM offers up to 47% more power on the motor shaft than before • Amplifier and motor dimensions reduced • Lower system costs | <ul style="list-style-type: none"> • Optimized AKM and direct drive motor windings for the AKD servo drive |
| <ul style="list-style-type: none"> • Quicker start-up of all servo systems • Immediate and adaptive reaction to dynamic loads optimizes performance within seconds • Precise regulation of all motor types • Compensation for stiff and compatible gearboxes and clutches | <ul style="list-style-type: none"> • Start-up of amplifiers with plug-and-play detection for AKM and Cartridge DDR series motors |
| <ul style="list-style-type: none"> • More precise machines due to higher resolution and improved accuracy • With multi-turn absolute encoders: reduced cycle times and lower costs for sensors and cabling through the omission of conventional reference run methods | <ul style="list-style-type: none"> • New, cost-efficient multi-turn feedback option |
| <ul style="list-style-type: none"> • Machine design independent of motor size • Installation of motors in the tightest space | <ul style="list-style-type: none"> • Motors with the highest power densities in the whole industry |
| <ul style="list-style-type: none"> • Over 500,000 standard motor versions available in various mounting, connection, and feedback variants, as well as further options • Our flexible products deliver a perfectly suited solution to your application • Simplifies mechanical modifications and design adjustments or renders them totally superfluous | <ul style="list-style-type: none"> • AKM offers 28 housing and design length combinations, as well as 120 different standard windings for a single motor series |
| <ul style="list-style-type: none"> • AKM Washdown and AKM Washdown Food also offer maximum reliability and a long service life for the most demanding industrial applications | <ul style="list-style-type: none"> • New IP67 option for AKM |

Kollmorgen Servo Motor Overview

Kollmorgen offers a comprehensive range of servo motors including electric cylinders, rodless actuators, and precision tables to meet a wide range of application requirements. For actuator products not included in this catalog go to www.kollmorgen.com for information about other Kollmorgen linear positioning products.

	Model	Product Family	Applications
	AKM Servo Motors	AKM	Designed with industry leading torque density and configurability. The AKM line includes more than 500,000 standard models to fit applications from general automation to applications that require IP67 sealing.
	AKMH IP69K Washdown Motors	AKMH	The AKMH meets the Food industry's strictest hygienic design criteria while being rugged enough to withstand the toughest of daily washdown regimens. Perfect for Food Processing, Primary Food Packaging, Pharmaceutical and Medical applications.
	Cartridge Direct Drive Servo Motors	CDDR	The CDDR is designed to provide the benefit of embedded frameless motor technology in an easy-to-integrate package. Perfect for applications in Printing, Packaging and Converting.
	Housed Direct Drive Servo Motors	HDDR	Housed DDR motors are designed for precise positioning of larger loads without the use of a mechanical transmission. Increasing OEE through the removal of belts and gearboxes that fail unexpectedly or require frequent maintenance.
	KBM Frameless Direct Drive Motors	KBM	With a wide variety of sizes and an extensive range of torque and speed options the KBM frameless direct drive motors are engineered to provide the high-performance, long life and simple installation that today's design engineers demand.
	TBM Frameless Direct Drive Motors	TBM	The Kollmorgen TBM frameless direct drive motors are designed for applications that require high power in a small, compact form factor with minimized weight and inertia. These motors provide the highest performance in applications such as robotic joints, medical robotics, sensor gimbals, guidance systems and other motion-critical applications.
	Direct Drive Linear Servo Motors	IC IL	Ideal for applications requiring very low bearing friction, high acceleration of lighter loads, and for maximizing constant velocity, even at ultra low speeds.

Model	Product Family	Features
AKM Servo Motors	AKM	Designed to deliver precise motion and more power for your money. More than 500,000 standard configurations that include various feedback, connector, paint and sealing options.
AKMH IP69K Washdown Motor	AKMH	The AKMH is designed to withstand the toughest of daily washdown regimens without need for covers. The AKMH's hygienic design makes it easy to clean, keeping your machine running and protecting your brand. Designed with a single cable that combines power, feedback and an innovative venting feature that extends the life of the motor.
Cartridge Direct Drive Servo Motors	CDDR	The CDDR is a patented design that allows for this torque dense frameless motor to be installed on your machine in 5 minutes. The CDDR lowers your machines maintenance, increases your machines uptime and increase your machines performance.
Housed Direct Drive Servo Motors	HDDR	Housed DDR motors are maintenance free and run more quietly and with better dynamics than systems that use gears, belts, cams or other mechanical transmission components.
KBM Frameless Direct Drive Motors	KBM	KBM motors cover a range of frameless motor solutions across a variety of applications. KBM is engineered to provide the high-performance, long life and simple installation that today's design engineers demand.
TBM Frameless Direct Drive Motors	TBM	Typical applications include robotic joints, weapon stations, sensor gimbals, sight systems, UAV propulsion and guidance, as well as many others.
Direct Drive Linear Servo Motors	IC IL	Kollmorgen linear motors provide precise placement of product by directly coupling to your load and eliminating the backlash associated with high maintenance linear transmission components.

AKM Brushless Servo Motor

The AKM™ brushless servo motor stands alone in the marketplace in terms of flexibility and performance advantages. Kollmorgen's culture of continuous improvement has paid dividends again. The AKM servo motor's innovative design has been polished and optimized. With the new AKD amplifier, the distinguished AKM servo motor sets a new standard of refined servo performance, designed to deliver precise motion and more power for your money. Nowhere else will you find a more versatile and complete servo family to meet your needs and exceed your expectations.

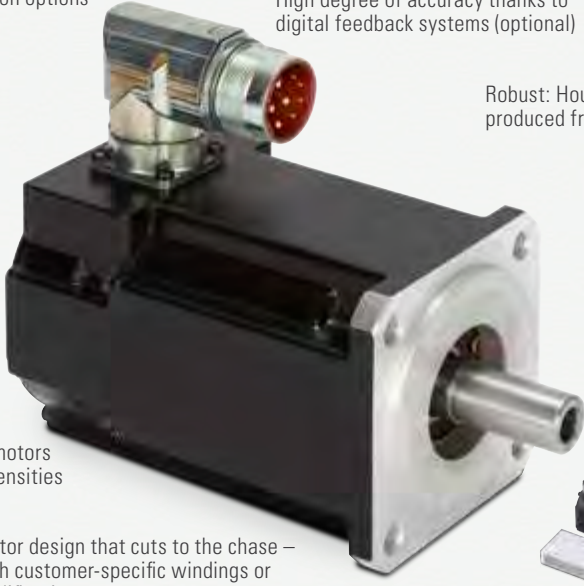

Numerous feedback options such as the SFD3 digital resolver, single-turn and multi-turn absolute encoders

Numerous connection options

High degree of accuracy thanks to digital feedback systems (optional)

Robust: Housing and front flange produced from one casting

Heavy-duty shaft, optionally with reinforced bearings (only AKM8)

Over 500,000 standard configurations

Smaller and lighter motors due to high torque densities

Motor design that cuts to the chase – with customer-specific windings or modifications.

Small but impressive: AKM1 is one of the smallest servo motors on the market

Worldwide availability and user support through the international Kollmorgen sales and support network

- 8 frame sizes from 40 to 260 mm
- 28 housing and design length combinations
- 117 standard windings for 120/240/400/480 V
- Winding options for low DC voltage
- Numerous flange and shaft options
- Minimal cogging and high degree of efficiency
- Extensive customization options with special windings and shafts



SERVO MOTORS
AKM BRUSHLESS SERVO MOTOR

Power Range

AKM frame sizes 1 to 8, standstill torques of 0.16 to 180 Nm, speed range 1000 to 8000 rpm, voltages 75 V DC, 120, 240, 400, 480 V AC.

Application Criteria

Universally deployable, brushless servo motors for all positioning and motion tasks with normal and high requirements and with accuracy and speed in a torque range between 0.16 Nm and 180 Nm.

Feedback Systems and Connectivity

Standard with SFD3 and HIPERFACE DSL single-cable options. In addition, AKM supports dual-cable feedback options such as Resolver, Encoder, EnDAT, and BiSS.

Protection Class

IP65 with optional Teflon shaft seal, IP67 in the Washdown or Washdown Food version (page 51). Standard version IP40.

Smooth Running and Long Service Life

Very smooth running due to minimal cogging. The single-cast stator ensures high stability and improved heat dissipation from the motor. Front flange and motor housing are produced from a single cast. This ensures a high degree of sealing and strength and a long service life.

High Accuracy

AKM Motor		Single-turn absolute			Multi-turn absolute		
		Accuracy (arc-min)	Resolution (bits)	Motor key	Accuracy (arc-min)	Resolution (bits)	Motor key
Value line	AKM1	16	24	CA	–	–	–
	AKM2 - AKM3	9	24	CA	8	18	LB
	AKM4 - AKM8	9	24	CA	4.66	18	LB
Performance line	AKM1	7.2	9	GP	7.2	9	GR
	AKM2 - AKM4	1.0	20	DA	1.0	20	DB
	AKM5 - AKM8	0.333	20	DA	0.333	20	DB

The AKM1 – one of the smallest servo motors on the market offers outstanding power density despite its compact design

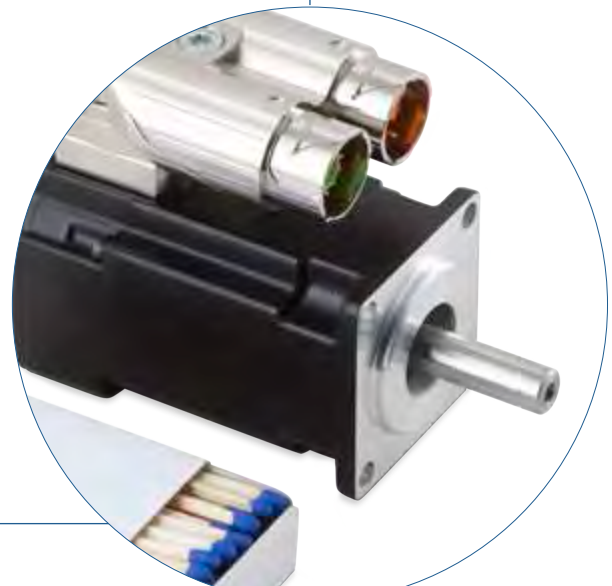
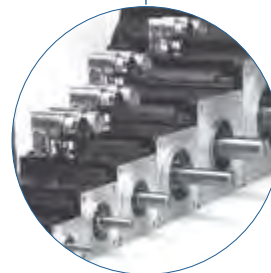
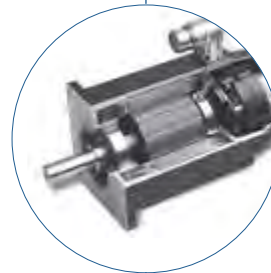

AKM Washdown and Washdown Food

Servo motors Suitable for use with Food

More durable in washdown conditions than standard AKM motors, lighter and more cost-effective than stainless-steel servo motors: In many applications with demanding environmental requirements, the AKM Washdown and Washdown Food versions are good alternatives to costly stainless steel motors or expensive protective enclosures.

Extensive range of options allows up to 150000 variants!

Housing design with rounded edges prevents contamination traps

Dual-component epoxy coating

Protection class IP67 allows for regular wet cleaning

Less weight due to stainless-steel-free housing

Lubricants suitable for use with food and shaft seal as per FDA requirements (Washdown Food)

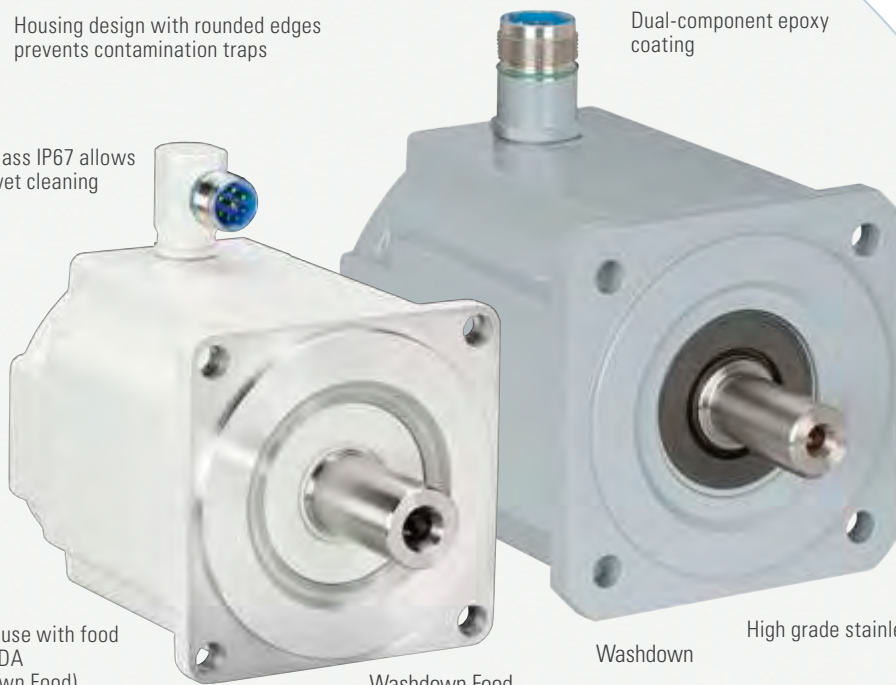

Washdown Food

Washdown

High grade stainless steel shaft

Chemical-resistant Teflon shaft seal

Specially for applications with demanding environmental requirements in the

- Packaging industry
- Pharmaceutical industry
- Food industry
- Beverage industry
- Laboratory automation
- Medical device technology



Power Range

AKM frame sizes 2 to 6 with standstill torques of 1 to 25 Nm, supply voltages of 75 to 480 V, large selection of different construction lengths, winding variants, as well as feedback systems and connection technologies.

Application Criteria

Designed for environments with acids, bases, or aggressive substances such as frequent cleaning with cleaning agents with pH values of between 2 and 12.

Housing Coating

The coating material of the AKM Washdown motors is resistant to acids and bases and aggressive substances and meets the global migration requirement of the FDA. The rounded and smooth surfaces prevent hazardous contamination traps and germ formation.

Seals and Bearings

Both Washdown versions meet the IP67 protection rating. The proven AKM PTFE shaft seal is used. For the AKM Washdown Food version, the shaft seal meets FDA requirements and only food-safe lubricants are used.

Connectors and Cables

Each in size 1 with special stainless steel design and smooth surface. Cables with special mating connectors are used from stainless steel or a material appropriate for maintaining food quality. The cables are clamped using a special clamping method.

International Standards

UL, CE, FDA*, RoHS

* Global migration requirement

Also proven in harsh environments: The AKM Washdown Food is resistant to most acids and bases, as well as aggressive substances.



AKM Servo Motors

AKM, AKM Washdown, and AKM Washdown Food

Performance Data

AKM Servo Motor	Flange size [mm]	Cont. Torque at Stall Tcs [Nm]	Continuous Current I _a [A]	Peak Torque at stall Tps [Nm]	75 V DC			115 V			230 V			400 V			480 V			Inertia (Jm) [kg-cm ²]	Weight [kg]
					Rated Speed Nrtd [RPM]	Rated Torque Trtd [Nm]	Rated Power Prtd [kW]	Rated Speed Nrtd [RPM]	Rated Torque Trtd [Nm]	Rated Power Prtd [kW]	Rated Speed Nrtd [RPM]	Rated Torque Trtd [Nm]	Rated Power Prtd [kW]	Rated Speed Nrtd [RPM]	Rated Torque Trtd [Nm]	Rated Power Prtd [kW]	Rated Speed Nrtd [RPM]	Rated Torque Trtd [Nm]	Rated Power Prtd [kW]		
11B	40	0.18	1.16	0.61	-	-	-	4000	0.18	0.08	8000	0.17	0.14	-	-	-	-	-	-	0.017	0.35
11C	40	0.18	1.45	0.61	-	-	-	6000	0.18	0.11	-	-	-	-	-	-	-	-	-	0.017	0.35
11E	40	0.18	2.91	0.61	6000	0.18	0.11	-	-	-	-	-	-	-	-	-	-	-	-	0.017	0.35
12C	40	0.31	1.51	1.08	-	-	-	4000	0.30	0.13	8000	0.28	0.23	-	-	-	-	-	-	0.031	0.49
12E	40	0.31	2.72	1.08	3000	0.31	0.10	8000	0.28	0.23	-	-	-	-	-	-	-	-	-	0.031	0.49
13C	40	0.41	1.48	1.46	-	-	-	3000	0.41	0.13	8000	0.36	0.30	-	-	-	-	-	-	0.045	0.63
13D	40	0.40	2.40	1.44	2000	0.40	0.08	7000	0.36	0.27	-	-	-	-	-	-	-	-	-	0.045	0.63
21C	60	0.48	1.58	1.47	-	-	-	2500	0.46	0.12	8000	0.39	0.32	-	-	-	-	-	-	0.11	0.82
21E	60	0.50	3.11	1.49	2000	0.48	0.10	7000	0.41	0.30	-	-	-	-	-	-	-	-	-	0.11	0.82
21G	60	0.50	4.87	1.51	4000	0.46	0.19	-	-	-	-	-	-	-	-	-	-	-	-	0.11	0.82
22C	60	0.84	1.39	2.73	-	-	-	1000	0.83	0.09	3500	0.78	0.29	8000	0.68	0.57	8000	0.68	0.57	0.16	1.10
22E	60	0.87	2.73	2.76	1000	0.85	0.09	3500	0.81	0.30	8000	0.70	0.59	-	-	-	-	-	-	0.16	1.10
22G	60	0.88	4.82	2.79	2500	0.83	0.22	7000	0.74	0.54	-	-	-	-	-	-	-	-	-	0.16	1.10
23C	60	1.13	1.41	3.77	-	-	-	1000	1.11	0.12	2500	1.08	0.28	5500	0.99	0.57	7000	0.95	0.70	0.22	1.38
23D	60	1.16	2.19	3.84	-	-	-	1500	1.12	0.18	5000	1.03	0.54	8000	0.92	0.77	8000	0.92	0.77	0.22	1.38
23F	60	1.18	4.31	3.88	1500	1.15	0.18	4500	1.07	0.50	8000	0.94	0.79	-	-	-	-	-	-	0.22	1.38
24C	60	1.38	1.42	4.67	-	-	-	-	-	-	2000	1.32	0.28	4500	1.25	0.59	5500	1.22	0.70	0.27	1.66
24D	60	1.41	2.21	4.76	-	-	-	1500	1.36	0.21	4000	1.29	0.54	8000	1.11	0.93	8000	1.11	0.93	0.27	1.66
24F	60	1.42	3.89	4.82	1000	1.39	0.15	3000	1.33	0.42	8000	1.12	0.94	-	-	-	-	-	-	0.27	1.66
31C	80	1.15	1.37	3.88	-	-	-	-	-	-	2500	1.12	0.29	5000	1.00	0.52	6000	0.91	0.57	0.33	1.55
31E	80	1.20	2.99	4.00	750	1.19	0.09	2500	1.17	0.31	6000	0.95	0.60	-	-	-	-	-	-	0.33	1.55
31H	80	1.23	5.85	4.06	2000	1.20	0.25	6000	0.97	0.61	-	-	-	-	-	-	-	-	-	0.33	1.55
32C	80	2.00	1.44	6.92	-	-	-	-	-	-	1500	1.95	0.31	3000	1.86	0.58	3500	1.83	0.67	0.59	2.23
32D	80	2.04	2.23	7.10	-	-	-	1000	2.00	0.21	2500	1.93	0.51	5500	1.65	0.95	6000	1.58	0.99	0.59	2.23
32E	80	2.04	2.82	7.11	-	-	-	-	-	-	3500	1.87	0.69	7000	1.41	1.03	7000	1.22	1.02	0.59	2.23
32H	80	2.10	5.50	7.26	1200	2.06	0.26	3000	1.96	0.62	7000	1.45	1.06	-	-	-	-	-	-	0.59	2.23
33C	80	2.71	1.47	9.76	-	-	-	-	-	-	1000	2.64	0.28	2000	2.54	0.53	2500	2.50	0.65	0.85	2.9
33E	80	2.79	2.58	9.96	-	-	-	-	-	-	2000	2.62	0.55	4500	2.34	1.10	5000	2.27	1.19	0.85	2.9
33H	80	2.88	5.62	10.22	800	2.82	0.24	2500	2.66	0.70	5500	2.27	1.31	-	-	-	-	-	-	0.85	2.9
41C	90	1.95	1.46	6.12	-	-	-	-	-	-	1200	1.88	0.24	3000	1.77	0.56	3500	1.74	0.64	0.81	2.44
41E	90	2.02	2.85	6.28	-	-	-	1200	1.94	0.24	3000	1.82	0.57	6000	1.58	0.99	6000	1.58	0.99	0.81	2.44
41H	90	2.06	5.6	6.36	1000	1.99	0.21	3000	1.86	0.58	6000	1.62	1.02	-	-	-	-	-	-	0.81	2.44
42C	90	3.35	1.40	11.3	-	-	-	-	-	-	-	-	-	1500	3.10	0.49	2000	3.02	0.63	1.5	3.39
42E	90	3.42	2.74	11.3	-	-	-	-	-	-	1800	3.12	0.59	3500	2.81	2.35	4000	2.72	1.14	1.5	3.39
42G	90	3.53	4.80	11.5	-	-	-	-	-	-	3500	2.90	1.06	6000	2.35	1.48	6000	2.35	1.48	1.5	3.39
42J	90	3.56	8.4	11.6	-	-	-	3000	3.03	0.95	6000	2.36	1.50	-	-	-	-	-	-	1.5	3.39
43E	90	4.70	2.76	15.9	-	-	-	-	-	-	1500	4.24	0.67	2500	3.92	1.03	3000	3.76	1.18	2.1	4.35
43G	90	4.80	4.87	16.1	-	-	-	-	-	-	2500	4.00	1.05	5000	3.01	1.58	6000	2.57	1.61	2.1	4.35
43K	90	4.90	9.60	16.4	-	-	-	2500	4.08	1.07	6000	2.62	1.65	-	-	-	-	-	-	2.1	4.35
44E	90	5.76	2.90	19.9	-	-	-	-	-	-	1200	5.22	0.66	2000	4.80	1.01	2500	4.56	1.19	2.7	5.3
44G	90	5.88	5.00	20.3	-	-	-	-	-	-	2000	4.90	1.03	4000	3.76	1.57	5000	3.19	1.67	2.7	5.3
44J	90	6.00	8.80	20.4	-	-	-	-	-	-	4000	3.84	1.61	6000	2.75	1.73	6000	2.75	1.73	2.7	5.3
51E	115	4.70	2.75	11.6	-	-	-	-	-	-	1200	4.41	0.55	2500	3.98	1.04	3000	3.80	1.19	3.4	4.2
51G	115	4.75	4.84	11.7	-	-	-	-	-	-	2500	4.02	1.05	5000	2.62	1.37	6000	1.94	1.22	3.4	4.2
51H	115	4.79	6.00	11.7	-	-	-	-	-	-	3000	3.87	1.22	6000	1.95	1.23	6000	1.95	1.23	3.4	4.2
51K	115	4.90	9.40	11.9	-	-	-	2500	4.15	1.09	5500	2.35	1.35	-	-	-	-	-	-	3.4	4.2

Performance Data

AKM Servo Motor	Frame size [mm]	Cont. Torque at Stall Tcs [Nm]	Continuous Current I _c [A]	Peak Torque at stall Tps [Nm]	230 V			400 V			480 V			Inertia (Jm) [kg-cm ²]	Weight [kg]
					Rated Speed N _{rd} [RPM]	Rated Torque T _{rd} [Nm]	Rated Power P _{rd} [kW]	Rated Speed N _{rd} [RPM]	Rated Torque T _{rd} [Nm]	Rated Power P _{rd} [kW]	Rated Speed N _{rd} [RPM]	Rated Torque T _{rd} [Nm]	Rated Power P _{rd} [kW]		
52E	115	8.34	2.99	21.3	-	-	-	1500	7.61	1.20	2000	7.28	1.52	6.2	5.8
52G	115	8.43	4.72	21.5	1200	7.69	1.21	2500	7.06	1.85	3000	6.66	2.09	6.2	5.8
52H	115	8.48	5.90	21.6	1800	7.53	1.42	3500	6.26	2.30	4000	5.77	2.42	6.2	5.8
52K	115	8.60	9.30	21.9	3000	6.80	2.14	5500	3.90	2.25	6000	3.25	2.04	6.2	5.8
52M	115	8.60	13.1	21.9	4500	5.20	2.45	-	-	-	-	-	-	6.2	5.8
53G	115	11.4	4.77	29.7	1000	10.7	1.12	2000	9.85	2.06	2400	9.50	2.39	9.1	7.4
53H	115	11.5	6.60	30.0	-	-	-	3000	8.63	2.77	3500	8.23	3.02	9.1	7.4
53K	115	11.6	9.40	30.3	2000	10.1	2.12	4000	7.65	3.20	4500	6.85	3.23	9.1	7.4
53M	115	11.4	13.4	29.7	3000	8.72	2.74	-	-	-	-	-	-	9.1	7.4
53P	115	11.4	19.1	29.8	5000	5.88	3.08	-	-	-	-	-	-	9.1	7.4
54G	115	14.3	5.00	38.0	-	-	-	1500	12.9	2.03	2000	12.3	2.57	12	9
54H	115	14.2	5.50	37.5	-	-	-	1500	12.6	2.38	2000	12.2	2.56	12	9
54K	115	14.4	9.7	38.4	1800	12.7	2.39	3500	10.0	3.68	4000	9.25	3.87	12	9
54L	115	14.1	12.5	37.5	2500	11.5	3.00	4500	8.13	3.83	-	-	-	12	9
54N	115	14.1	17.8	37.6	3500	9.85	3.61	-	-	-	-	-	-	12	9
62G	142	11.9	4.9	29.7	-	-	-	1800	10.4	1.96	2000	10.2	2.14	17	8.9
62K	142	12.2	9.6	30.2	2000	10.4	2.18	3500	9.00	3.30	4500	8.00	3.77	17	8.9
62M	142	12.2	13.4	30.2	3000	9.50	2.98	6000	5.70	3.58	6000	5.70	3.58	17	8.9
62P	142	12.3	18.8	30.3	4500	8.10	3.82	-	-	-	-	-	-	17	8.9
63G	142	16.5	4.5	42.1	-	-	-	1200	14.9	1.87	1500	14.6	2.29	24	11.1
63K	142	16.8	9.9	42.6	1500	14.9	2.34	3000	12.9	4.05	3500	12.0	4.40	24	11.1
63M	142	17.0	13.8	43.0	2000	14.3	2.99	4000	11.3	4.73	4500	10.5	4.95	24	11.1
63N	142	17.0	17.4	43.0	3000	13.0	4.08	5000	9.60	5.03	6000	7.00	4.40	24	11.1
64K	142	20.8	9.2	53.5	1200	18.8	2.36	2000	17.2	3.60	2500	16.3	4.27	32	13.3
64L	142	21.0	12.8	54.1	1500	18.4	2.89	3000	15.6	4.90	3500	14.4	5.28	32	13.3
64P	142	20.4	18.6	52.9	2500	16.0	4.19	4500	11.9	5.62	5500	9.00	5.18	32	13.3
64Q	142	20.0	20.7	53.2	3000	15.3	4.81	5000	10.7	6.45	6000	7.40	4.65	32	13.3
65K	142	24.8	9.8	64.5	1000	22.8	2.39	2000	20.2	4.23	2200	19.7	4.54	40	15.4
65M	142	25.0	13.6	65.2	1500	21.9	3.44	2500	19.2	5.03	3000	18.1	5.69	40	15.4
65N	142	24.3	17.8	63.7	2000	19.8	4.15	3500	16.0	5.86	4000	14.7	6.16	40	15.4
65P	142	24.5	19.8	64.1	2400	19.1	4.8	4000	14.9	6.24	5000	11.6	6.08	40	15.4
72K	180	29.7	9.3	79.4	-	-	-	1500	25.1	3.94	1800	24.0	4.52	65	19.7
72M	180	30.0	13.0	79.8	-	-	-	2000	23.6	4.94	2500	22.1	5.79	65	19.7
72P	180	29.4	18.7	78.5	1800	23.8	4.49	3000	20.1	6.31	3500	18.2	6.67	65	19.7
72Q	180	29.5	23.5	78.4	2000	23.2	4.89	4000	16.3	6.83	4500	14.1	6.65	65	19.7
73M	180	42.0	13.6	112	-	-	-	1500	33.8	5.31	1800	32.1	6.05	92	26.7
73P	180	41.6	19.5	111	1300	34.7	4.72	2400	28.5	7.16	2800	26.3	7.71	92	26.7
73Q	180	41.5	24.5	111	1500	33.4	5.25	3000	25.2	7.92	3500	22	8.07	92	26.7
74L	180	53.0	12.9	143	-	-	-	1200	43.5	5.47	1400	41.5	6.08	120	33.6
74P	180	52.5	18.5	142	-	-	-	1800	39.6	7.46	2000	35.9	7.52	120	33.6
74Q	180	52.2	26.1	141	1300	41.9	5.71	2500	31.5	8.25	3000	27.3	8.58	120	33.6
82T	260	75	48	210	-	-	-	2500	47.5	12.4	3000	38.0	11.9	172	49
83T	260	130	62	456	-	-	-	2200	70.0	16.1	2500	60.0	15.7	334	73
83V	260	130	91	304	-	-	-	3000	65	20.4	-	-	-	334	73
84T	260	180	67	668	-	-	-	1800	105	19.8	2000	93.0	19.5	495	97

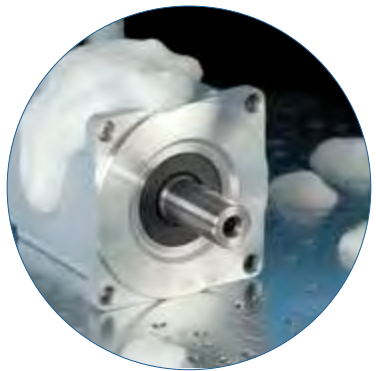
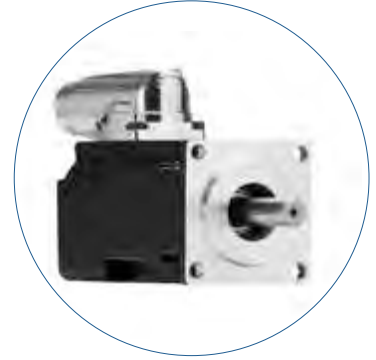

AKM Brushless Servo Motor

SERVO MOTORS

AKM BRUSHLESS SERVO MOTOR

AKM, AKM Washdown, and AKM Washdown Food

Model with Power and Signal Connector

Dimensional drawing for AKM11 - AKM84

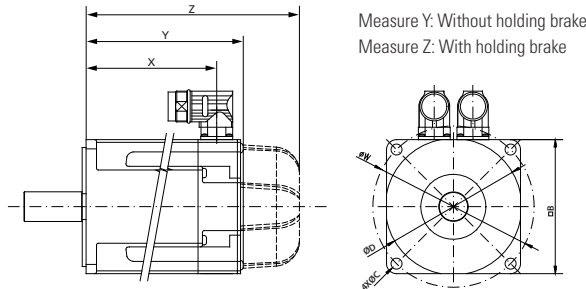

All measurement specifications in mm Measure Y: Measurement without holding brake, Measure Z: Measurement with holding brake

Model	X	Resolvers		Comcoder		Biss/Endat		Hiperface		Flange □B	Bolt circle ØW	Bore diameter ØC	Centering collar ØD
		Y	Z	Y	Z	Y	Z	Y	Z				
AKM11	56.1	69.6	106.6	79.0	—	—	—	79	116	40	46	4.3	30
AKM12	75.1	88.6	125.6	98.0	—	—	—	98	135	40	46	4.3	30
AKM13	94.1	107.6	144.6	117.0	—	—	—	117	154	40	46	4.3	30
AKM21	76.1	95.4	129.5	95.4	129.5	95.4	129.5	113.4	147.1	58	63	4.8	40
AKM22	95.1	114.4	148.5	114.4	148.5	114.4	148.5	132.4	166.1	58	63/65 (1)	4.8	40
AKM23	114.1	133.4	167.5	133.4	167.5	133.4	167.5	151.4	185.1	58	63/65 (1)	4.8	40
AKM24	135.1	152.4	186.5	152.4	186.5	152.4	186.5	170.4	204.1	58	63/65 (1)	4.8	40
AKM31	87.9	109.8	141.3	109.8	141.3	109.8	141.3	125.3	159.3	70	75/85 (2)	5.8	60
AKM32	118.9	140.8	172.3	140.8	172.3	140.8	172.3	156.3	190.3	70	75/85 (2)	5.8	60
AKM33	149.9	171.8	203.3	171.8	203.3	171.8	203.3	187.3	221.3	70	75/85 (2)	5.8	60
AKM41	96.4	118.8	152.3	118.8	152.3	118.8	152.3	136.8	170.3	84	90/100 (3)	7	60/80 (3)
AKM42	125.5	147.8	181.3	147.8	181.3	147.8	181.3	165.8	199.3	84	90/100 (3)	7	60/80 (3)
AKM43	154.4	176.8	210.3	176.8	210.3	176.8	210.3	194.8	228.3	84	90/100 (3)	7	60/80 (3)
AKM44	183.4	205.8	239.3	205.8	239.3	205.8	239.3	223.8	257.3	84	90/100 (3)	7	60/80 (3)
AKM51	105.3	127.5	172.5	127.5	172.5	145.0	189.0	145.0	189.0	108	115/130 (4)	7	95/110 (4)
AKM52	136.3	158.5	203.5	158.5	203.5	177.0	220.0	177.0	220.0	108	115/130 (4)	7	95/110 (4)
AKM53	167.3	189.5	234.5	189.5	234.5	208.0	251.0	208.0	251.0	108	115/130 (4)	7	95/110 (4)
AKM54	198.3	220.5	265.5	220.5	265.5	239.0	282.0	239.0	282.0	108	115/130 (4)	7	95/110 (4)
AKM62	130.5	153.7	200.7	153.7	200.7	172.2	219.7	172.2	219.7	138	165	11	130
AKM63	155.5	178.7	225.7	178.7	225.7	197.2	244.7	197.2	244.7	138	165	11	130
AKM64	180.5	203.7	250.7	203.7	250.7	222.2	269.7	222.2	269.7	138	165	11	130
AKM65	205.5	228.7	275.7	228.7	275.7	247.2	294.7	247.2	294.7	138	165	11	130
AKM72	164.5	192.5	234.5	192.5	234.5	192.5	234.5	192.5	234.5	188	215	13.5	180
AKM73	198.5	226.5	268.5	226.5	268.5	235.7	287.3	235.7	287.3	188	215	13.5	180
AKM74	232.5	260.5	302.5	260.5	302.5	269.7	321.3	269.7	321.3	188	215	13.5	180
AKM82	170	267	333	267	333	267	333	267	333	260	300	18.5	250
AKM83	250.5	347.5	413.5	347.5	413.5	347.5	413.5	347.5	413.5	260	300	18.5	250
AKM84	331	428	494	428	494	428	494	428	494	260	300	18.5	250

(1) ØW = 63 mm AKM2xx-Ax
 ØW = 65 mm AKM2xx-Dx

(2) ØW = 75 mm AKM3xx-Ax
 ØW = 85 mm AKM3xx-Cx

(3) ØW = 100 mm, ØV = 80 mm AKM4xx-Ax
 ØW = 90 mm, ØV = 60 mm AKM4xx-Cx

(4) ØW = 130 mm ØV = 110 mm AKM5xx-Ax
 ØW = 115 mm ØV = 95 mm AKM5xx-Ax

The Design Features of AKM in the 3D Model

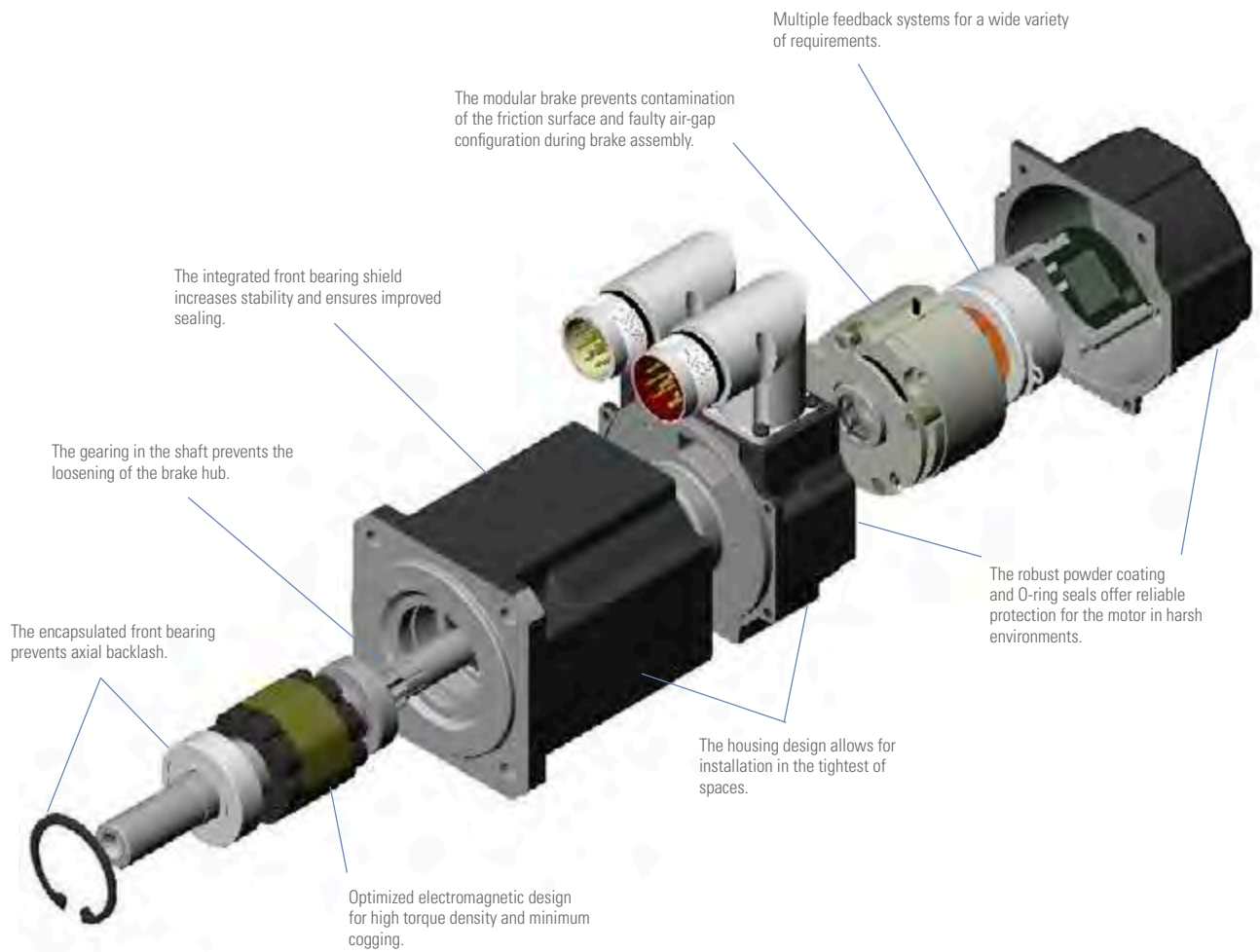

AKMH™

Hygienic Stainless Steel Servo Motors

For more than 70 years, Kollmorgen has been developing special motors for use in difficult environments. For example, the remotely controlled submarine vehicle called the Jason Jr. discovered the wreck of the Titanic with the help of Kollmorgen motors developed especially for this purpose.

Reduced recall risk. In the food production industry extremely strict hygiene regulations apply so that public health is not compromised. The stainless-steel AKMH servo motors meet the most demanding requirements in relation to hygiene standards and reduce the risk of product contamination and costly recalls.

Faster cleaning and reduced maintenance times. The stainless steel AKMH servo motors are designed to protection class IP69K and satisfy the requirements of the EHEDG and 3A hygiene regulations. Only materials are used that are FDA-approved and suitable for use with food. These characteristics of the AKMH series enable quick, hygienic cleaning, reduce maintenance times, and therefore increase the overall equipment effectiveness of your production line.

The bottom line. The stainless steel AKMH series of motors has been designed for hygienic machine applications. The large product range with 19 standard motor frame sizes, multiple standard windings, and numerous connection, brake, and cable options makes it easier to choose a motor that satisfies the requirements of the highest standards in the food, beverage, and pharmaceutical industries.

The Advantages of AKMH Hygienic Stainless Steel Servo Motors

Increase in Overall Equipment Effectiveness (OEE)

Faster and environmentally friendly cleaning	<ul style="list-style-type: none"> • Open, hygienic machine design without protective housings • Considerably lower consumption of cleaning agents; less dirty water
No machine downtimes as a result of cleaning or corrosion	<ul style="list-style-type: none"> • Protection class IP69K for motor housing, cable gland, and shaft seal • Designed for regular high-pressure and high-temperature cleaning • Cable and sealing components are resistant to common cleaning agents • No corrosion inside the motor: Pressure compensation through the cable prevents moisture in the motor
Lower operating costs	<ul style="list-style-type: none"> • Higher machine availability due to quicker cleaning • Faster cleaning reduces the consumption of cleaning agents and energy • High energy efficiency due to motor / servo drive combination with a high degree of efficiency
Higher throughput	<ul style="list-style-type: none"> • Quick and precise drives in combination with the AKD servo drives • Process monitoring and optimization with Kollmorgen's software tools

Lower risk of recalls

Hygiene-optimized housing design	<ul style="list-style-type: none"> • Housing is 1.4404 stainless steel 316L with smooth surface prevents the build-up of pathogens • Fluids drained with vertical installation thanks to convex cover • No place for pathogens to hide - no nooks and crannies in housing design • Thanks to a laser annealed nameplate, the surface finish is undisturbed
Use of approved hygienic components	<ul style="list-style-type: none"> • Bearing lubrication and shaft seals FDA-approved • Observance of the EHEDG and 3A Sanitary Certificate hygienic regulations
Hygienic cable technology	<ul style="list-style-type: none"> • Silicon tubing option provides an FDA-approved cable option suitable for use with food • Low cabling costs due to single-cable technology - no need for expensive stainless steel conduit • Non absorbant cabling prevent pathogens from hiding in the cable jacket material

Reduced development times and design freedom

Ideal motor design	<ul style="list-style-type: none"> • Large selection of standard motors allowing customers to optimize their motor selection • 19 frame sizes, flange and shaft measurements as per IEC and NEMA • Continuous torques up to 22 Nm, peak torques up to 92 Nm • Speeds up to 8000 rpm⁻¹ • SFD3 and Hiperface DSL digital feedback systems • Brake and cable options
Simple start-up and parameterization	<ul style="list-style-type: none"> • Plug-and-play connection with pre-assembled connectable cables, no screw connections • Simple machine architecture due to single-cable and decentralized connection technology • Digital nameplate for quick start-up • Software tools for parameterization and drive monitoring
Low energy consumption	<ul style="list-style-type: none"> • High efficiency due to permanent magnet technology • 20% less derating due to special motor design
Kollmorgen support	<ul style="list-style-type: none"> • Kollmorgen's global support team has wealth of industry knowledge to help optimize your machine
Co-engineering	<ul style="list-style-type: none"> • Kollmorgen welcomes customization to help optimize your motor/drive solution

AKMH Hygienic Stainless Steel Servo Motors

The new stainless steel AKMH motors have been designed for hygienic machine applications in wet areas with food contact in accordance with the EHEDG regulations and they comply with 3A, USDA* and NFS hygiene standards. Shorter cleaning times and high reliability ensure noticeably greater overall equipment effectiveness.

Specially suited to applications where contact with food is possible

Extremely durable, even with frequent, intensive cleaning processes

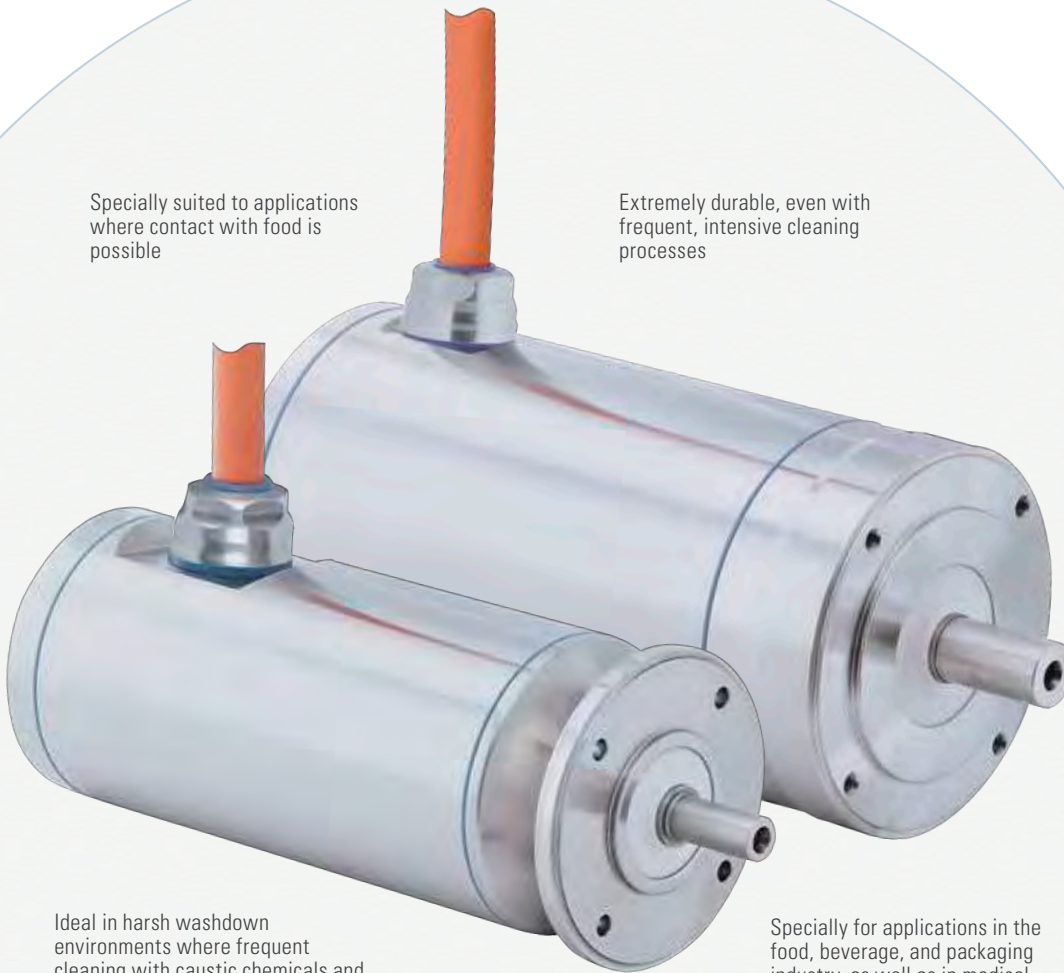

Ideal in harsh washdown environments where frequent cleaning with caustic chemicals and high pressure water are required.

Specially for applications in the food, beverage, and packaging industry, as well as in medical devices



* In preparation

Higher Productivity Due to Quicker Cleaning

- Ideal for machines with an open design
- No costly protective equipment; no hidden spaces to trap pathogens
- Quick, easy, yet safe cleaning

Reduced Recall Risk

- Lubricants and seals meet FDA standards.
- Round, stainless steel housing with a roughness of $< 0.8 \mu\text{m}$ and the design of all edges with radii of R1.5 prevent dirt deposits

Higher Machine Uptime

- IP69K: Motor is protected for water pressures up to 1450 PSI
- Cable is directly mounted to motor; no connectors to fail or trap pathogens
- Single-cable technology with digital feedback (SFD3 or HIPERFACE® DSL digital resolvers); less cabling to clean

Outstanding Efficiency Thanks to Novel Motor Design

- Torque derating under 20%
- High speeds of up to 8000 RPM offer more flexibility for gearbox attachment and higher productivity due to higher output speeds with the same torque
- AKMH2 is the most compact hygienic servo motor on the market

Optimized Motion Thanks to 19 Frame Sizes

- 5 sizes each with 4 rotor lengths and winding options for perfect adaptation to servo drives
- Two housing shapes for front and flange mounting

One Source for Your Complete Automation Solution

- The Kollmorgen Automation Suite provides all the tools for motion and PLC programming and for drive management in operation
- AKD-PDMM multi-axis controller: The 3-in-1 solution combines servo drive, motion controller, and PLC in one device

Thanks to the open machine design without protective housings, machines can also be cleaned quickly and safely using high-pressure and high-temperature processes.

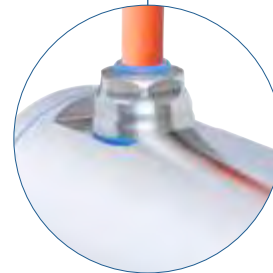
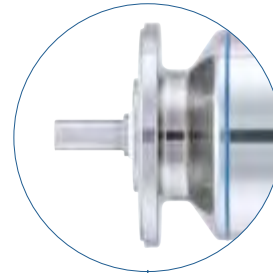

AKMH Design Features

The key benefits of AKMH clean design features:

- Reduces risk of food recall
- Increases reliability in wash-down application
- Reduces cleaning time: higher OEE

■ No protective covers required for washdown... no secondary cleaning disassembly required

■ Smooth surface meeting EHEDG & 3A criteria, promotes rapid cleaning and no harboring of pathogens

■ All exposed surfaces are 316 stainless, superior to 304/303 for hygiene & corrosion resistance

■ External O-ring and gasket sealing with blue FDA approved materials

■ Chemical resistant cable for pH of 2-12, meeting IEC60364-5-52, UL, CSA, CE, RoHS

■ Conical end cover to eliminate water puddling, even in vertical mounting

■ FDA food-grade approved tubing over cable for food zone applications

■ No external hardware (no bolts, washers, or screws) to trap soil & pathogens or fall into food

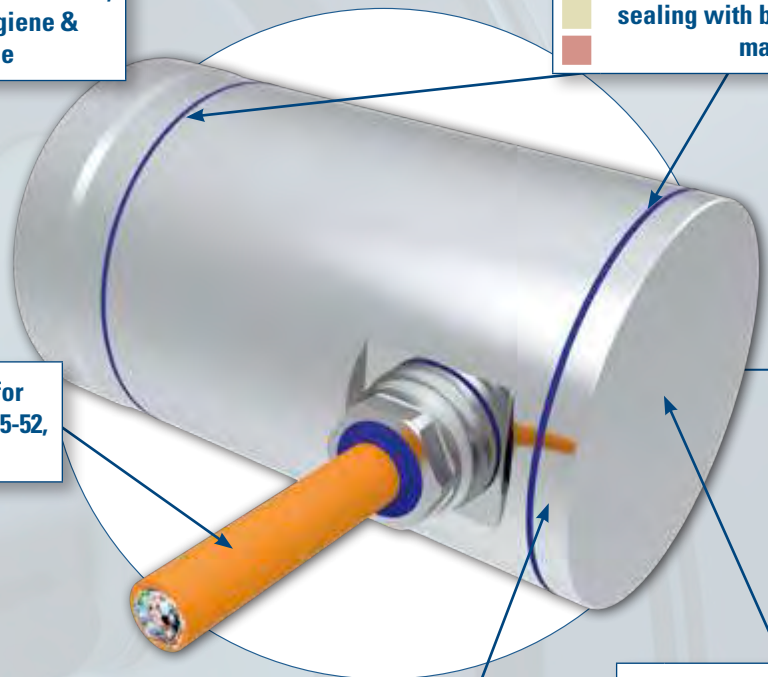

SERV O M O T O R S
A K M H W A S H D O W N M O T O R

■ Hygienic marking method eliminates
■ harboring of pathogens

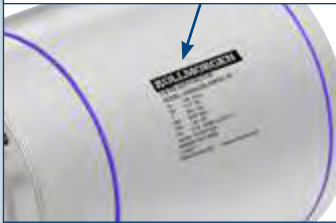

■ Unique design technique to
■ eliminate condensation

■ Single cable for increased reliability,
■ faster cleaning, and fewer places to
■ harbor pathogens

■ Water-tight cable exit

■ Face Mount for most hygienic
■ design, Flange Mount option for
 easy mounting

■ Hygienic, IP69K shaft seal,
■ special shaft treatment for
■ long life

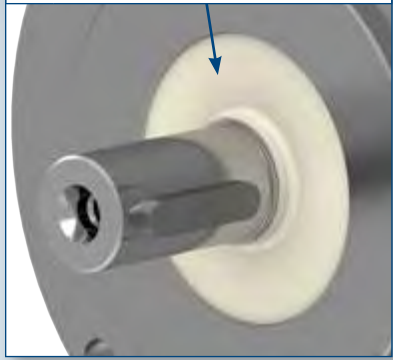
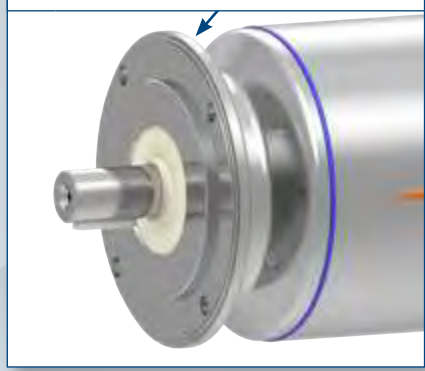

AKMH Hygienic Stainless Steel Servo Motors

SERVO MOTORS

AKMH WASHDOWN MOTOR

Performance Data

AKMH Servo Motor	Cont. Torque at Stall T_{cs} [Nm] ①②③	Continuous Current I_c [A] ①②③	Peak Torque at stall T_{ps} [Nm] ①②③	75 V DC			160 V DC			320 V DC V			560 V DC			640 V DC			Inertia J_m [kg·cm ²]	Weight [kg]
				Rated Speed N _{rd} [RPM]	Rated Torque T _{rd} [Nm] ①②③	Rated Power P _{rd} [kW] ①②③	Rated Speed N _{rd} [RPM]	Rated Torque T _{rd} [Nm] ①②③	Rated Power P _{rd} [kW] ①②③	Rated Speed N _{rd} [RPM]	Rated Torque T _{rd} [Nm] ②③④	Rated power P _r [kW] ①②③	Rated Speed N _{rd} [RPM]	Rated Torque T _{rd} [Nm] ①②③	Rated Power P _{rd} [kW] ①②③	Rated Speed N _{rd} [RPM]	Rated Torque T _{rd} [Nm] ①②③	Rated Power P _{rd} [kW] ①②③		
21C	0.317	1.31	1.57	-	-	-	2500	0.311	0.08	8000	0.255	0.21	8000	0.255	0.21	8000	0.255	0.21	0.107	3.6
21E	0.329	2.56	1.59	2000	0.324	0.068	7000	0.28	0.21	-	-	-	-	-	-	-	-	-	0.107	3.6
21G	0.335	4.04	1.60	4000	0.318	0.13	-	-	-	-	-	-	-	-	-	-	-	-	0.107	3.6
22C	0.633	1.18	3.03	-	-	-	1000	0.627	0.07	3500	0.583	0.21	8000	0.40	0.34	8000	0.40	0.34	0.161	4.1
22E	0.654	2.33	3.07	1000	0.647	0.07	3500	0.601	0.22	8000	0.41	0.35	-	-	-	-	-	-	0.161	4.1
22G	0.661	4.09	3.09	2500	0.632	0.17	7000	0.473	0.35	-	-	-	-	-	-	-	-	-	0.161	4.1
23D	0.897	1.88	4.35	-	-	-	1500	0.881	0.14	5000	0.765	0.40	8000	0.58	0.49	8000	0.58	0.49	0.216	4.6
23E	0.904	2.36	4.37	-	-	-	2500	0.865	0.23	6500	0.688	0.47	-	-	-	-	-	-	0.216	4.6
23F	0.917	3.67	4.41	1500	0.900	0.14	4500	0.806	0.38	8000	0.593	0.50	-	-	-	-	-	-	0.216	4.6
24D	1.12	1.90	5.50	-	-	-	1500	1.11	0.17	4000	1.04	0.44	8000	0.83	0.70	8000	0.83	0.70	0.27	5.1
24E	1.12	2.39	5.51	-	-	-	2000	1.10	0.23	5500	0.98	0.57	-	-	-	-	-	-	0.27	5.1
24F	1.13	3.34	5.53	1000	1.12	0.12	3000	1.09	0.34	8000	0.839	0.70	-	-	-	-	-	-	0.27	5.1
31C	1.00	1.29	4.41	-	-	-	-	-	-	2500	0.95	0.25	5000	0.86	0.45	6000	0.82	0.51	0.33	4.1
31E	1.04	2.76	4.52	750	1.03	0.08	2500	0.96	0.25	6000	0.86	0.54	8000	0.74	0.62	-	-	-	0.33	4.1
31H	1.08	5.51	4.59	2000	1.04	0.22	6000	0.88	0.55	-	-	-	-	-	-	-	-	-	0.33	4.1
32C	1.72	1.30	8.10	-	-	-	-	-	-	1500	1.66	0.26	3000	1.57	0.49	3500	1.52	0.56	0.59	5.0
32E	1.77	2.56	8.24	-	-	-	-	-	-	3500	1.57	0.57	7000	1.10	0.81	8000	0.92	0.77	0.59	5.0
32H	1.82	4.98	8.39	1200	1.78	0.22	3000	1.66	0.52	7000	1.13	0.83	-	-	-	-	-	-	0.59	5.0
33C	2.25	1.27	11.5	-	-	-	-	-	-	1000	2.22	0.23	2000	2.14	0.45	2500	2.09	0.55	0.85	5.9
33E	2.32	2.20	11.7	-	-	-	-	-	-	2000	2.20	0.46	4500	1.82	0.86	5000	1.72	0.90	0.85	5.9
33H	2.38	4.80	11.9	800	2.35	0.20	2500	2.20	0.58	5500	1.64	0.94	8000	0.88	0.74	-	-	-	0.85	5.9
41C	1.85	1.54	6.82	-	-	-	-	-	-	1200	1.78	0.22	3000	1.68	0.53	3500	1.65	0.60	0.81	6.1
41E	1.90	2.89	6.95	-	-	-	1200	1.85	0.23	3000	1.74	0.55	6000	1.44	0.90	6000	1.44	0.90	0.81	6.1
41H	1.94	5.82	7.00	1000	1.89	0.20	3000	1.77	0.56	6000	1.47	0.92	-	-	-	-	-	-	0.81	6.1
42C	3.19	1.42	12.6	-	-	-	-	-	-	-	-	-	1500	2.98	0.47	2000	2.91	0.61	1.45	7.4
42E	3.27	2.77	12.8	-	-	-	-	-	-	1800	2.99	0.56	3500	2.72	1.00	4000	2.62	1.10	1.45	7.4
42H	3.40	6.10	13.1	-	-	-	2000	3.09	0.65	4500	2.63	1.24	6000	2.21	1.39	6000	2.21	1.39	1.45	7.4
42J	3.43	8.56	13.1	-	-	-	3000	2.94	0.92	6000	2.23	1.40	-	-	-	-	-	-	1.45	7.4
43E	4.56	2.79	18.3	-	-	-	-	-	-	1500	4.15	0.65	2500	3.83	1.00	3000	3.68	1.16	2.09	8.8
43H	4.68	5.52	18.7	-	-	-	-	-	-	3000	3.77	1.18	6000	2.44	1.53	6000	2.44	1.53	2.09	8.8
43L	4.59	11.4	18.4	-	-	-	3000	3.69	1.16	6000	2.39	1.50	-	-	-	-	-	-	2.09	8.8
44E	5.64	2.89	23.5	-	-	-	-	-	-	1200	5.13	0.64	2000	4.76	1.00	2500	4.52	1.18	2.73	10.2
44H	5.77	5.68	23.5	-	-	-	-	-	-	2500	4.59	1.20	5000	3.13	1.64	6000	2.58	1.62	2.73	10.2
44K	5.76	10.2	23.5	-	-	-	2000	4.83	1.01	5000	3.10	1.62	6000	2.55	1.60	-	-	-	2.73	10.2
51E	3.3	2.28	15.0	-	-	-	-	-	-	1200	3.11	0.39	2500	2.83	0.74	3000	2.68	0.84	3.42	8.9
51H	3.39	5.02	15.0	-	-	-	-	-	-	3000	2.75	0.86	5500	1.41	0.81	5500	1.41	0.81	3.42	8.9
51L	3.47	10.0	15.2	-	-	-	3000	2.82	0.89	5500	1.45	0.84	-	-	-	-	-	-	3.42	8.9

① Motor winding excess temperature, $\Delta T = 100$ K with ambient temperature = 40°C

② All specifications refer to sinusoidal supply

③ Rated data with reference flange (aluminum, dims (mm): AKMH2, AKMH3, AKMH4: 254 x 254 x 6.35 AKMH5: 305 x 305 x 12.7 AKMH6: 457 x 457 x 12.7)

Performance Data

AKMH Servo Motor	Cont. Torque at Stall Tcs [Nm] ①②③	Continuous Current I _a [A] ①②③	Peak Torque at stall Tps [Nm] ①②③	75 V DC			160 V DC			320 V DC V			560 V DC			640 V DC			Inertia (Jm) [kg·cm ²]	Weight [kg]
				Rated Speed N _{rd} [RPM]	Rated Torque T _{rd} [Nm] ①②③	Rated Power P _{rd} [kW] ①②③	Rated Speed N _{rd} [RPM]	Rated Torque T _{rd} [Nm] ①②③	Rated Power P _{rd} [kW] ①②③	Rated Speed N _{rd} [RPM]	Rated Torque T _{rd} [Nm] ②③④	Rated power P _a [kW] ①②③	Rated Speed N _{rd} [RPM]	Rated Torque T _{rd} [Nm] ①②③	Rated Power P _{rd} [kW] ①②③	Rated Speed N _{rd} [RPM]	Rated Torque T _{rd} [Nm] ①②③	Rated Power P _{rd} [kW] ①②③		
52E	6.15	2.43	28.9	-	-	-	-	-	-	-	-	1500	5.39	0.85	2000	5.08	1.06	6.22	11.1	
52H	6.29	4.81	29.1	-	-	-	-	-	-	1800	5.32	1.00	3500	3.44	1.26	4000	2.44	1.02	6.22	11.1
52L	6.45	9.50	29.5	-	-	-	-	-	-	3500	3.53	1.29	4500	1.19	0.56	4500	1.19	0.561	6.22	11.1
52M	6.39	10.7	29.4	-	-	-	-	-	-	4500	1.18	0.556	-	-	-	-	-	-	6.22	11.1
53H	8.60	5.29	41.8	-	-	-	-	-	-	-	-	-	3000	4.06	1.28	3500	2.12	0.78	9.12	13.4
53L	8.68	9.43	42.0	-	-	-	-	-	-	3000	4.09	1.28	3500	2.14	0.78	3500	2.14	0.78	9.12	13.4
53P	8.49	15.2	41.7	-	-	-	-	-	-	3500	2.09	0.77	-	-	-	-	-	-	9.12	13.4
54H	10.5	4.35	53.3	-	-	-	-	-	-	1000	9.31	3.00	1800	7.62	1.44	2000	7.09	1.48	11.92	15.7
54L	10.4	9.82	53.3	-	-	-	-	-	-	2500	5.13	1.34	3000	2.47	0.78	-	-	-	11.92	15.7
54P	10.6	15.3	53.9	-	-	-	-	-	-	3000	2.52	0.79	-	-	-	-	-	-	11.92	15.7
62H	10.6	5.3	39.8	-	-	-	-	-	-	1000	10.5	1.10	1800	9.93	1.87	2000	9.86	2.07	16.9	19.6
62L	10.8	11.7	40.1	-	-	-	-	-	-	2500	9.61	2.52	5000	4.95	2.59	5500	3.31	1.91	16.9	19.6
62M	10.9	13.1	40.2	-	-	-	-	-	-	3000	9.10	2.86	5500	3.33	1.92	5500	3.33	1.92	16.9	19.6
63H	14.6	5.2	57.9	-	-	-	-	-	-	-	-	-	1500	13.6	2.14	1800	13.2	2.49	24.2	23.1
63L	14.8	10.6	58.4	-	-	-	-	-	-	1800	13.4	2.53	3000	11.1	3.49	3500	9.60	3.52	24.2	23.1
63M	15.0	13.0	58.8	-	-	-	-	-	-	2000	13.3	2.79	4000	7.90	3.31	4500	5.70	2.69	24.2	23.1
64K	18.7	8.7	75.1	-	-	-	-	-	-	1200	17.1	2.15	2000	15.6	3.27	2500	14.2	3.72	31.6	26.7
64L	19.0	12.1	75.6	-	-	-	-	-	-	1500	16.8	2.64	3000	12.5	3.93	3500	10.0	3.67	31.6	26.7
64K	21.9	9.1	91.4	-	-	-	-	-	-	1000	20.2	2.12	2000	17.7	3.71	2500	17.1	3.94	40.0	30.2
64L	22.2	11.3	92.0	-	-	-	-	-	-	1300	19.7	2.68	2500	16.0	4.19	2800	14.5	4.25	40.0	30.2
64M	22.2	12.6	92.0	-	-	-	-	-	-	1500	19.4	3.44	2700	15.1	4.27	3000	13.5	5.69	40.0	30.2

① Motor winding excess temperature, ΔT = 100 K with ambient temperature = 40°C

② All specifications refer to sinusoidal supply

③ Rated data with reference flange (aluminum, dims (mm): AKMH2, AKMH3, AKMH4: 254 x 254 x 6.35 AKMH5: 305 x 305 x 12.7 AKMH6: 457 x 457 x 12.7)

Flange / Shaft Combinations

Type	AC	AN	BK	BN	CC	CN	DK	DN	GC	GN	HC	HN
Mounting	Flange	Flange	Flange	Flange	Front	Front	Front	Front	Flange	Flange	Front	Front
Standard	IEC	IEC	NEMA	NEMA	IEC	IEC	NEMA	NEMA	IEC	IEC	IEC	IEC
Shaft	Closed Keyway	Smooth	Open Keyway	Smooth	Closed Keyway	Smooth	Open Keyway	Smooth	Closed Keyway	Smooth	Closed Keyway	Smooth
AKMH 2x	●	●	-	●	●	●	-	●	-	-	-	-
AKMH 3x	●	●	-	-	●	●	-	-	-	-	-	-
AKMH 4x	●	●	●	●	●	●	●	●	-	-	-	-
AKMH 5x	●	●	●	●	●	●	●	●	●	●	●	●
AKMH 6x	●	●	-	-	●	●	●	●	-	-	-	-

AKMH Hygienic Stainless Steel Servo Motors

SERVO MOTORS

AKMH WASHDOWN MOTOR

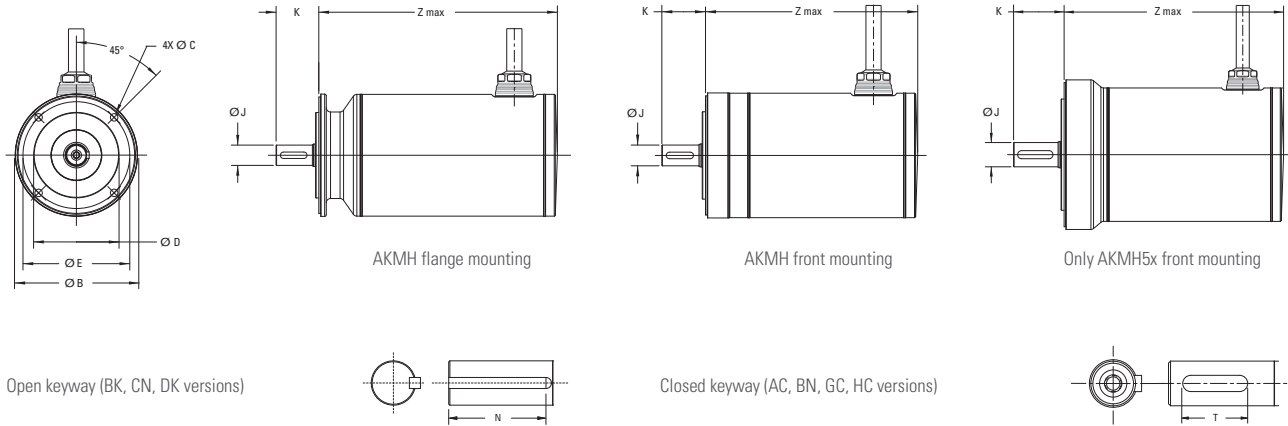

Dimensions (mm)

Model	Z max. SFD3 digital resolver		Z max. Hiperface DSL		Flange
	without brake	with brake	without brake	with brake	ØB
AKMH21	167.2	201.2	180.2	214.2	79
AKMH22	186.2	220.2	199.2	233.2	79
AKMH23	205.2	239.2	218.2	252.2	79
AKMH24	224.2	258.2	237.2	271.2	79
AKMH31	166.5	198.0	182.5	214.0	89
AKMH32	197.5	229.0	213.5	245.0	89
AKMH33	228.5	260.0	244.5	276.0	89
AKMH41	166.7	201.0	182.7	217.0	113
AKMH42	195.7	230.0	211.7	246.0	113
AKMH43	224.7	259.0	240.7	275.0	113
AKMH44	253.7	288.0	269.7	304.0	113
AKMH51	187.4	229.4	198.4	240.4	148
AKMH52	218.4	260.4	229.4	271.4	148
AKMH53	249.4	291.4	260.4	302.4	148
AKMH54	280.4	322.4	291.4	333.4	148
AKMH61	209.9	256.5	220.9	267.5	186
AKMH62	234.9	281.5	245.9	292.5	186
AKMH63	259.9	306.5	270.9	317.5	186
AKMH64	284.9	331.5	295.9	342.5	186

Dimensions (mm)

AKMH XX-		AC	AN	BK	BN	CC	CN	DK	DN	GC	GN	HC	HN
Mounting		Flange		Flange		Front	Front	Front	Front	Flange	Flange	Front	Front
Standard		IEC		NEMA		IEC	IEC	NEMA	NEMA	IEC	IEC	IEC	IEC
Shaft		Closed Keyway	Smooth	Open Keyway	Smooth	Closed Keyway	Smooth	Open Keyway	Smooth	Closed Keyway	Smooth	Closed Keyway	Smooth
AKMH 2x	Ø C	4.80		–	5.10	M4 x 0.7 x 8.0		–	UNF10-32	–		–	
	Ø D	40		–	38.10	40		–	38.1	–		–	
	Ø E	63		–	66.68	63		–	66.68	–		–	
	Ø J	11		–	9.524	11		–	9.524	–		–	
	K	30		–	31.8	30.0		–	31.8	–		–	
	N/T	T = 16	NA	–	NA	T = 16	NA	–	NA	–		–	
AKMH 3x	Ø C	5.80		–	–	M5 x 0.8 x 10.0		–	–	–		–	
	Ø D	60		–	–	60		–	–	–		–	
	Ø E	75		–	–	75		–	–	–		–	
	Ø J	14		–	–	14		–	–	–		–	
	K	30		–	–	30.0		–	–	–		–	
	N/T	T = 16	NA	–	–	T = 16	NA	–	–	–		–	
AKMH 4x	Ø C	7.0		–	6.91	M6 x 1 x 12		UNC 1/4 - 20 x 12.3		–		–	
	Ø D	80		–	73.025	80		73.025	73	–		–	
	Ø E	100		–	98.43	100		98.43		–		–	
	Ø J	19		–	15.875	19		15.875		–		–	
	K	40.0		–	52.40	40.0		52.40		–		–	
	N/T	T = 25	NA	N = 34.93	NA	T = 25	NA	N = 34.93	NA	–		–	
AKMH 5x	Ø C	9		–	8.33	M8 x 1.25 x 16.0		UNC 3/8 - 16 x 19.05		9		M8 x 1.25 x 16.0	
	Ø D	110		–	55.560	110		55.563		95		95	
	Ø E	130		–	125.73	130		125.73		115		115	
	Ø J	24		–	19.05	24		19.05		24		24	
	K	50.0		–	57.15	50.0		57.15		50.0		50.0	
	D	T = 36	NA	N = 38.1	NA	T = 36	NA	N = 38.1	NA	T = 36	NA	T = 36	N = 38.1
AKMH 6x	Ø C	11.00		–	–	M10 x 1.5 x 20.0		UNC 3/8 - 16 x 19.05		–		–	
	Ø D	130		–	–	130		114.3		–		–	
	Ø E	165.0		–	–	165.0		149.23		–		–	
	Ø J	32		–	–	32		28.580		–		–	
	K	58		–	–	58		69.9		–		–	
	D	40	NA	–	–	T = 40	NA	N = 38.10	NA	–		–	

Direct Drive Rotary Motors

SERVO MOTORS
 DIRECT DRIVE ROTARY MOTORS

Conventional servo systems commonly have a mechanical transmission which can consist of gears, gearboxes, belts/pulleys or cams connected between the motor and the load.

With Direct Drive Rotary Motors, the mechanical transmission is eliminated and the motor is coupled directly to the load.

Why Use Direct Drive Rotary Motors?

Increased Accuracy and Repeatability

A “precision” planetary gearbox could have a backlash of 1 arc-minute. This can result in the load moving by 1 arc-minute with an absolutely stationary drive motor. Kollmorgen’s standard direct drive rotary (DDR) servo motors have repeatability better than 1 arc-second. Therefore, a direct drive motor can hold a position 60 times better than a conventional motor/gearbox.

The increased accuracy of direct drive rotary motors results in a higher quality product out of the machine:

- Print registration is more accurate
- Cut or feed lengths can be held more precisely
- Coordination with other machine axes is more accurate
- Indexing location is more exact
- Tuning issues due to backlash are eliminated

Higher Bandwidth

Mechanical transmission components impose a limit on how fast a machine can start and stop and also extend the required settling time. These factors limit the possible throughput of a machine.

Direct drive rotary motors remove these limitations and allows for much faster start/stop cycles and also provide greatly reduced settling time. This will allow a greater throughput from the machine. Users of direct drive systems have reported up to a 2X increase in throughput.

Improved Reliability and Zero Maintenance

Gears, belts, and other mechanical transmission parts break. By eliminating these parts and using DDR motors, the reliability of the machine is improved. Gearboxes require periodic lubrication and/or replacement in aggressive start/stop applications. Belts require periodic tightening. There are no time-wear components in a direct drive motor and consequently they require zero maintenance.

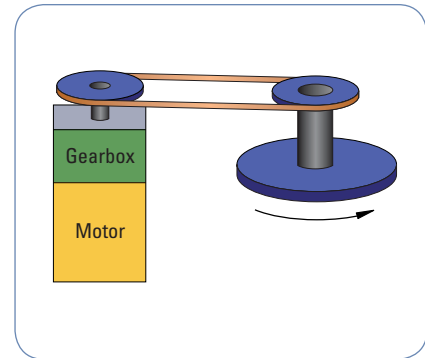

Servo Motor and Gearbox



Direct Drive Motor

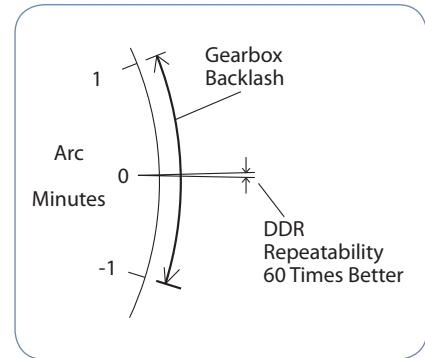

Improved Repeatability

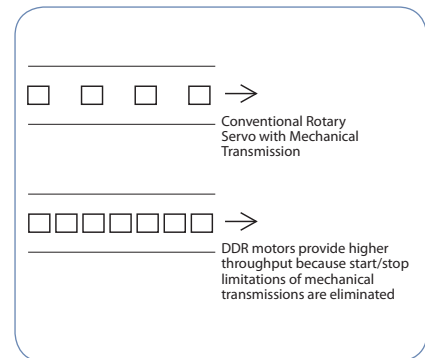

Increased Throughput

Fewer Parts

With direct drive motors, all you need is the motor and the mounting bolts. This often replaces many parts including brackets, guards, belts, pulleys, tensioners, couplings, and bolts, resulting in:

- Fewer parts on the BOM. Less parts to purchase, schedule, inventory and control, and less parts to assemble.
- Assembly time of the servo drops from several hours with the mechanical transmission to several minutes with the DDR.
- Reduced cost. Although a direct drive motor may carry a small price-premium compared to a motor/gearbox with the same torque, consider that there is an overall cost reduction when eliminating the parts and labor of all the extra components required in a servo system with mechanical transmission.

No Inertia Matching

Servo systems with mechanical transmissions require inertia matching that limits the reflected load inertia at 5 to 10 times the motor inertia. If this limitation is not met, the system becomes difficult to control due to instability issues. Inertia matching limitations of mechanical transmission systems often force machine designers to use a larger motor than would otherwise be required just to satisfy the inertia matching requirement.

Such sizing conventions are not required with direct drive rotary motors. Since the motor is directly connected to the load, the inertia of the motor and the load become a common inertia. Therefore, no inertia matching is required when using DDR. DDR applications have run with inertia ratios greater than 11,000:1.

Reduced Audible Noise

Machines with DDR motors have audible noise levels as low as 20 dB less than the same machine with a mechanical transmission.

Direct Drive Linear (DDL) Motor

Directly coupling a linear motor to the driven load offers many advantages, including eliminating all mechanical transmissions, such as ball/lead screws, rack & pinions, belts/pulleys, and eliminating gearboxes. This in turn also eliminates backlash and compliance, and other problems associated with these mechanical transmissions.

DDL Applications

Format	Where Used
Ironless (IL) Series	Applications requiring zero cogging or high acceleration of low mass loads
Ironcore (IC or ICD) Series	Applications requiring highest thrust forces for their size
Water-cooled (IC) Series	Applications requiring the highest possible force

Three DDR Product Categories to Choose From

Kollmorgen's 50 years of electromagnetic and electromechanical design experience combined with our quality and service, allowed us to refine and expand DDR motors into three product categories for easy installation, use, and short lead times: Frameless DDR, Housed DDR, and the Cartridge DDR. This allows you to select the right DDR solution for your application.

Frameless DDR

Frameless motors include a rotor and stator as separate components which are integrated into, ride on the bearings of, and become a part of the driven load. Frameless motors offer the most compact and lightweight DDR solution available. The KBM and TBM series are Kollmorgen's latest Frameless DDR products. The KBM provides excellent torque/volume with the use of a proprietary neodymium-iron magnet rotor structure and skewed armature assembly. The KBM series is the first UL recognized parts set available on the market. This provides OEMs with the benefits of UL component ratings for easier agency approval on their machines. The TBM frameless motor is a new series of direct drive torque motors designed for applications that require high power in a small, compact form factor with minimized weight and inertia.

Housed DDR

The Housed DDR is a housed motor assembly featuring a factory aligned high-resolution feedback device and precision bearings, allowing it to function as the core of rotary indexing and rate table applications. The system can also be used as a flexible indexer, providing programmable, rapid indexing far exceeding the throughput and accuracy of conventional mechanical or variable reluctance indexers.

Cartridge DDR

This motor is the first in the industry to combine the space-saving and performance advantages of Frameless DDR motors with the ease of installation of a full-frame motor. Consisting of a rotor, stator, and factory-aligned high-resolution feedback device, the motor uses the machine's bearings to support the rotor. An innovative compression coupling engages the rotor to the load and the frame of the motor mounts to the machine with a bolt circle and pilot diameter just like a conventional servo motor, saving space and design time and simplifying the overall system.

DDR Applications

Format	Where Used
Frameless DDR	Application where size and weight must be absolutely minimized
Housed DDR	Applications where the load rides on the motor's bearings such as indexing or rate tables
Cartridge DDR	Any application with existing bearings

Cartridge Direct Drive Rotary (CDDR) Motor

The Cartridge Direct Drive Rotary (CDDR) Motor is the first in the industry to combine the space-saving and performance advantages of frameless CDDR technology with the ease of installation of a full-frame motor. CDDR motors also feature an advanced electromagnetic design that provides up to 50% more torque density than comparably sized conventional servo motors.

Consisting of a rotor, stator, factory-aligned high-resolution feedback device, the CDDR motor uses the machine's bearings to support the rotor. An innovative compression coupling secures the CDDR's rotor to the machine shaft, and the CDDR's housing is bolted to the machine frame with a bolt circle and pilot – just like a conventional servo motor. Also, mechanical transmission components are eliminated, saving space and design time while simplifying the overall system.



Features

Benefits

- | | |
|--|---|
| <ul style="list-style-type: none"> • Integrated compression coupling and shipping hardware | <ul style="list-style-type: none"> • Eliminate parts and labor for a faster and lower cost machine build • Assembles in 5 minutes |
| <ul style="list-style-type: none"> • 5 frame sizes, multiple lengths • 230 / 400 / 480 Vac windings available (high and low) • Continuous torque range: 4.57 N-m (3.37 lb-ft) to 510 N-m (373 lb-ft) • Speeds up to 2,500 RPM • Optimized torque output with high-pole count efficient electromagnetic design • Hollow shaft available on C09x and C13x models, provides a 1.26 inch (32 mm) through bore to allow process or wiring to run through the center of the motor. Provision for mounting a rotary union to the shaft and housing is included. | <ul style="list-style-type: none"> • Satisfies a wide range of machine requirements and configurations |
| <ul style="list-style-type: none"> • Integrated high-resolution sine encoder • 134,217,728 counts / rev • Low cogging for smooth low-speed rotation • Zero backlash and compliance | <ul style="list-style-type: none"> • Increased accuracy and higher throughput |
| <ul style="list-style-type: none"> • Direct load connection eliminates gearboxes, belts, or pulleys | <ul style="list-style-type: none"> • Greater machine reliability and reduced maintenance • Reduced audible noise, fewer parts and lower cost of ownership • More compact machine and reduced design time |

The Cartridge DDR Advantage – Press Feed Machine

Consider how Cartridge DDR technology improves a Press Feed machine:

Reduced Assembly Time

The assembly time for the original mechanical transmission system was 4 hours. In contrast, the Cartridge DDR motor is installed in less than 5 minutes, resulting in a significant cost savings in labor.

Reduced Parts Count

The original mechanical transmission system comprises 2 bracket pieces, 12 bolts, 2 pulleys, 2 set screws, 2 keys, a timing belt, a housing to protect operators from the timing belt, a tension system for the timing belt, and motor/gearbox. With the Cartridge DDR system, this is all replaced by the motor and 4 mounting bolts, resulting in fewer parts to maintain and cost savings.

Improved Accuracy

The best planetary gearboxes have a backlash between 1 and 2 arc-minutes. Over the life of the gearbox, the backlash will increase. The Cartridge DDR system has an absolute accuracy of 26 arc-seconds and a repeatability of 0.7 arc-seconds. The Press Feed machine with the Cartridge DDR has a feed accuracy of +/- 0.0005 inch where the Press Feed machine with the mechanical transmission has a feed accuracy of 0.002 inch. Therefore, there was an overall four times improvement in machine accuracy with the Cartridge DDR system.

Increased Throughput

The cycle rate of the Cartridge DDR system is two times better than the mechanical transmission. This results in an increase in throughput of 100 percent.

Improved Reliability and Simplified Maintenance

The Cartridge DDR system eliminates parts that wear, change over time, or fail. Gearboxes are prone to wear, and backlash increases over time. Belts and pulleys stretch and require maintenance to maintain proper belt tension. By eliminating these components, the Cartridge DDR system delivers greater system reliability.

Press Feed Example

Gearboxes have a finite life span, especially in a demanding cyclic application such as a Press Feed. On this machine, the gearbox must be replaced every 10,000 hours and the belt must be tensioned every 2,000 hours. By contrast, the Cartridge DDR motor has no wear components and requires no maintenance thus simplifying the maintenance schedule for the machine, including operating costs.

Reduced Audible Noise

The Cartridge DDR system has as much as a 20 dB reduction in noise compared to a mechanical transmission servo system. This can dramatically reduce the overall noise level of the machine. A quieter machine gives the perception of quality. This is rightfully so as the noise emitted by gears and belts is caused by the wearing of the parts.

Total Reduced Cost

A Cartridge DDR motor typically costs 20 percent more than a comparable motor/gearbox combination. However, the elimination of parts and assembly time typically results in a lower total cost for the Cartridge DDR solution.



Press feed machine built with a conventional servo motor, gearbox, belt and pulleys.



Same machine with a Cartridge DDR motor installed. Here, the shaft of the driven roll is extended into the Cartridge DDR motor and the motor applies torque directly to the driven roll.

Cartridge Direct Drive Rotary Motor (DDR)

240 Vac Performance Data

Cartridge DDR Motor	Servo Drive	Frame Size	Continuous Torque	Peak Torque	Maximum Speed	Weight	Inertia (Jm)
		mm (in)	Nm (lb-in)	Nm (lb-in)	RPM	kg (lb)	kg-cm ² (lb-in-s ² x10 ⁻³)
C041A	AKD-X00306	108 (4.25)	4.57 (40.4)	12.3 (109)	1750	4.08 (9.00)	5.86 (5.19)
C041B	AKD-X00606	108 (4.25)	4.52 (40.0)	12.2 (108)	2500	4.08 (9.00)	5.86 (5.19)
C042A	AKD-X00606	108 (4.25)	8.25 (73.0)	22.2 (196)	1700	5.67 (12.5)	8.87 (7.85)
C042B	AKD-X01206	108 (4.25)	8.45 (74.8)	22.8 (202)	2500	5.67 (12.5)	8.87 (7.85)
C043A	AKD-X00606	108 (4.25)	11.1 (98.2)	30.0 (265)	1250	7.26 (16.0)	11.9 (10.5)
C043B	AKD-X01206	108 (4.25)	11.2 (99.1)	30.2 (267)	2500	7.26 (16.0)	11.9 (10.5)
C044A	AKD-X00606	108 (4.25)	13.9 (123)	37.4 (331)	1050	8.84 (19.5)	14.9 (13.2)
C044B	AKD-X01206	108 (4.25)	14.1 (125)	37.9 (335)	2150	8.84 (19.5)	14.9 (13.2)
C051A	AKD-X00606	138 (5.43)	11.7 (104)	30.2 (267)	1200	8.39 (18.5)	27.4 (24.2)
C051B	AKD-X01206	138 (5.43)	11.9 (105)	30.6 (271)	2450	8.39 (18.5)	27.4 (24.2)
C052C	AKD-X00606	138 (5.43)	16.9 (150)	43.1 (381)	950	10.7 (23.5)	35.9 (31.8)
C052D	AKD-X01206	138 (5.43)	16.5 (146)	42.3 (374)	2050	10.7 (23.5)	35.9 (31.8)
C053A	AKD-X01206	138 (5.43)	21.0 (186)	54.1 (479)	1350	13.2 (29.0)	44.3 (39.2)
C053B	AKD-X02406	138 (5.43)	20.2 (179)	50.1 (443)	2500	13.2 (29.0)	44.3 (39.2)
C054A	AKD-X01206	138 (5.43)	24.9 (220)	63.8 (565)	1200	15.4 (34.0)	52.8 (46.7)
C054B	AKD-X02406	138 (5.43)	23.8 (211)	61.2 (542)	2500	15.4 (34.0)	52.8 (46.7)
C061A	AKD-X01206	188 (7.40)	33.8 (299)	86.8 (768)	900	18.6 (41.0)	94.1 (83.2)
C061B	AKD-X02406	188 (7.40)	32.6 (288)	75.6 (669)	1950	18.6 (41.0)	94.1 (83.2)
C062C	AKD-X01206	188 (7.40)	48.4 (428)	117 (1040)	700	23.6 (52.0)	126 (112)
C062B	AKD-X02406	188 (7.40)	44.6 (395)	102 (900)	1400	23.6 (52.0)	126 (112)
C063C	AKD-X01206	188 (7.40)	61.8 (547)	157 (1380)	550	29.0 (63.0)	157 (139)
C063B	AKD-X02406	188 (7.40)	59.0 (522)	136 (1200)	1050	29.0 (63.0)	157 (139)
C091A	AKD-X02406	246 (9.68)	50.2 (444)	120 (1060)	600	27.7 (61.0)	280 (248)
C092C	AKD-X02406	246 (9.68)	102 (900)	231 (2050)	450	41.3 (91.0)	470 (416)
C093C	AKD-X02406	246 (9.68)	139 (1230)	317 (2800)	350	54.4 (120)	660 (584)
C131C	AKD-X02406	350 (13.8)	189 (1670)	395 (3500)	250	63.5 (140)	1240 (1100)
C132C	AKD-X02406	350 (13.8)	362 (3200)	818 (7240)	120	101 (223)	2250 (1990)
C133C	AKD-X02406	350 (13.8)	499 (4410)	1070 (9890)	100	132 (292)	3020 (2670)

400/480 Vac Systems Performance Data

Cartridge DDR Motor	Servo Drive	Frame Size	Continuous Torque	Peak Torque	Maximum Speed		Weight	Inertia (Jm)
		mm (in)	Nm (lb-in)	Nm (lb-in)	RPM		kg (lb)	kg-cm ² (lb-in-s ² x10 ⁻³)
					400 Vac	480 Vac		
CH041A	AKD-X00307	108 (4.25)	4.56 (40.4)	11.3 (100)	2500	2500	4.08 (9.00)	5.86 (5.19)
CH042A	AKD-X00607	108 (4.25)	8.26 (73.1)	19.0 (168)	2500	2500	5.67 (12.5)	8.87 (7.85)
CH043A	AKD-X00607	108 (4.25)	11.1 (98.2)	25.3 (224)	2250	2500	7.26 (16.0)	11.9 (10.5)
CH044A	AKD-X00607	108 (4.25)	13.9 (123)	31.6 (280)	1850	2250	8.84 (19.5)	14.9 (13.2)
CH051A	AKD-X00607	138 (5.43)	11.7 (104)	28.0 (248)	2100	2500	8.39 (18.5)	27.4 (24.2)
CH052C	AKD-X00607	138 (5.43)	16.9 (150)	43.1 (381)	1750	2100	10.7 (23.5)	35.9 (31.8)
CH053A	AKD-X01207	138 (5.43)	21.0 (186)	54.1 (479)	2350	2500	13.2 (29.0)	44.3 (39.2)
CH054A	AKD-X01207	138 (5.43)	24.9 (220)	63.8 (565)	2100	2500	15.4 (34.0)	52.8 (46.7)
CH061A	AKD-X01207	188 (7.40)	33.8 (299)	86.8 (768)	1600	1900	18.6 (41.0)	94.1 (83.2)
CH062C	AKD-X01207	188 (7.40)	48.4 (428)	117 (1040)	1250	1550	23.6 (52.0)	126 (112)
CH063C	AKD-X01207	188 (7.40)	61.8 (547)	157 (1380)	950	1150	29.0 (63.0)	157 (139)
CH063B	AKD-X02407	188 (7.40)	59.0 (522)	136 (1200)	1850	2200	29.0 (63.0)	157 (139)
CH091A	AKD-X02407	246 (9.68)	50.2 (444)	120 (1060)	1200	1500	27.7 (61.0)	280 (248)
CH092C	AKD-X02407	246 (9.68)	102 (900)	231 (2050)	800	1000	41.3 (91.0)	470 (416)
CH093C	AKD-X02407	246 (9.68)	139 (1230)	317 (2800)	700	800	54.4 (120)	660 (584)
CH131C	AKD-X02407	350 (13.8)	189 (1670)	395 (3500)	500	600	63.5 (140)	1240 (1100)
CH131B	AKD-X04807	350 (13.8)	190 (1680)	396 (3500)	800	1000	63.5 (140)	1240 (1100)
CH132C	AKD-X02407	350 (13.8)	362 (3200)	818 (7240)	250	300	101 (223)	2250 (1990)
CH132B	AKD-X04807	350 (13.8)	361 (3190)	759 (6720)	400	500	101 (223)	2250 (1990)
CH133C	AKD-X02407	350 (13.8)	499 (4410)	1070 (9480)	200	250	132 (292)	3020 (2670)
CH133B	AKD-X04807	350 (13.8)	510 (4510)	1016 (9042)	350	400	132 (292)	3020 (2670)

Note 1: For complete CDDR and AKD model nomenclature, refer to pages 176 and 181 respectively.

Cartridge DDR C04, C05 and C06 Dimensions

Cartridge DDR Motor	A mm (in)	B mm (in)	C mm (in)	D mm (in)
C(H)041	171 (6.73)	108 (4.25)	59 (2.31)	93 (3.67)
C(H)042	202 (7.95)	108 (4.25)	59 (2.31)	93 (3.67)
C(H)043	233 (9.17)	108 (4.25)	59 (2.31)	93 (3.67)
C(H)044	264 (10.4)	108 (4.25)	59 (2.31)	93 (3.67)
C(H)051	195 (7.68)	138 (5.43)	76 (3.00)	108 (4.25)
C(H)052	220 (8.66)	138 (5.43)	76 (3.00)	108 (4.25)
C(H)053	245 (9.65)	138 (5.43)	76 (3.00)	108 (4.25)
C(H)054	270 (10.6)	138 (5.43)	76 (3.00)	108 (4.25)
C(H)061	226 (8.90)	188 (7.40)	99 (3.88)	133 (5.25)
C(H)062	260 (10.2)	188 (7.40)	99 (3.88)	133 (5.25)
C(H)063	294 (11.6)	188 (7.40)	99 (3.88)	133 (5.25)

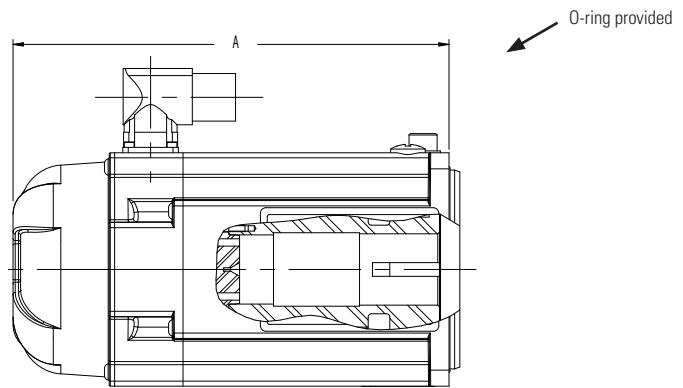
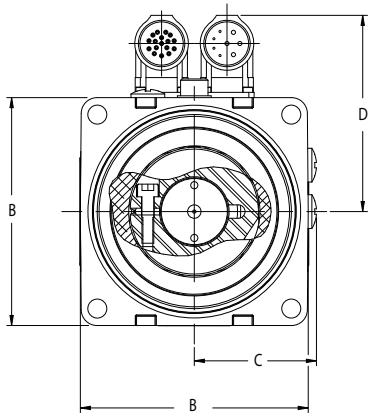

Cartridge DDR C09 and C13 Dimensions

Cartridge DDR Motor	A mm (in)	B mm (in)	C mm (in)	D mm (in)
C(H)091	204 (8.03)	246 (9.68)	149 (5.88)	182 (7.18)
C(H)092	253 (9.96)	246 (9.68)	149 (5.88)	182 (7.18)
C(H)093	302 (11.9)	246 (9.68)	149 (5.88)	182 (7.18)
C(H)131	231 (9.09)	350 (13.8)	200 (7.87)	256 (10.1)
C(H)132	301 (11.9)	350 (13.8)	200 (7.87)	256 (10.1)
C(H)133	370 (14.6)	350 (13.8)	200 (7.87)	256 (10.1)

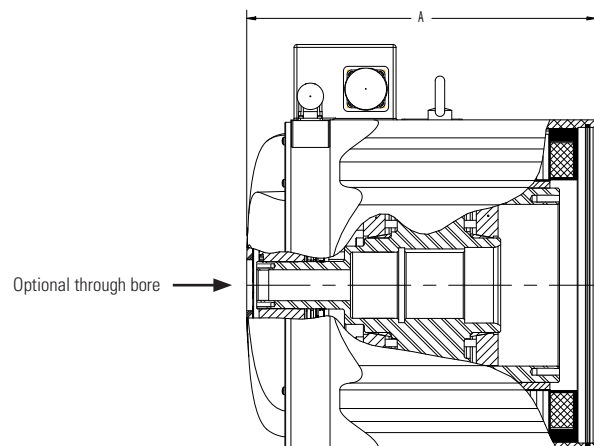
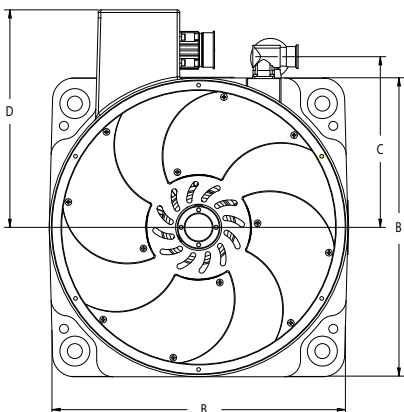

Housed Direct Drive Rotary (DDR) Motor



Housed DDR Features

- 4 frame sizes
- Robust cross-roller bearing
- Dual bearing option
- IP67 option
- Continuous torque range: 5.8 Nm (4.3 lb-ft) to 339 Nm (250 lb-ft)
- Optimized torque output with high-pole count efficient electromagnetic design
- Integrated high-resolution sine-encoder
- 134,217,728 counts per rev resolution, 27 bits
- Feedback accuracy: +/- 26 arc-sec
- Repeatability better than 1 arc second

Housed DDR Motor Advantage

Consider how a Housed DDR motor improved a medical manufacturing machine.

Product is located at the steel pins on the outside of the machine's turret as shown. The 115 kg load wheel has an inertia of 20 kg-m². There are 96 steel pins for an index angle of 3.5 degrees to move.

The move is accomplished in less than 100 ms.

Housed DDR Benefits

- Transmission elements such as couplings, toothed belts, spindles, and other fitted components can be eliminated
- Mechanical design is made much simpler
- Power transmission without backlash
- More compact machinery assemblies
- Increased performance for the entire system

Housed DDR motors are multi-pole (16 to 32) hollow shaft motors with their own bearings and high-resolution encoder system. They are coupled directly to the load and enable very precise and repeatable systems. Housed DDR motors are maintenance free and run more quietly and with better dynamics than systems that use gears, belts, cams or other mechanical transmission components.

Realized Housed DDR Motor Benefits

The Direct Drive Advantage

The following improvements were observed compared to the previous design that used a mechanical indexer:



Improved Repeatability

The Housed DDR motor demonstrated a repeatability better than 1 arc-second which was substantially better than the mechanical indexer.

No Degradation

Direct drive system performance, accuracy and repeatability do not degrade over time as they do with a mechanical indexer. With a mechanical indexer, as parts wear over time, the accuracy and repeatability degrade.

Immediate Stop

The direct drive system can immediately stop if there is a process error. The mechanical indexer required several cycles to stop which could cause tooling and machine damage.

Greatly Reduced Audible Noise

With the mechanical indexer, the noise was at a level such that two people would have to yell to hear each other. By contrast, if you turned your back to the Housed DDR motor, you could barely detect that it was running.

Easy Profile Change

Motion parameters such as index angle, speed, acceleration, and dwell are very simple to change with the Housed DDR motor. The mechanical indexer does not support flexible motion profiles.

Better Value

The Housed DDR motor is attractively priced compared to the mechanical indexer it replaced. When the other advantages listed above are also considered, the Housed DDR motor was the obvious choice.

Housed DDR Performance Data and Dimensions

240 Vac Performance Data

Housed DDR Motor	AKD Servo Drive	Frame Size mm (in)	Continuous Torque Nm (lb-in)	Peak Torque Nm (lb-in)	Maximum Speed (RPM)	Weight kg (lb)	Inertia (Jm) cm ² (lb-in-s ² x10 ⁻³)
D061	AKD-X00606	175 (6.90)	5.3 (46.9)	16.9 (150)	500	9.4 (20.7)	61 (54.0)
D062	AKD-X00606	175 (6.90)	9.8 (86.7)	33.5 (296)	500	11.3 (24.9)	71 (62.8)
D063	AKD-X00606	175 (6.90)	17.7 (157)	64.4 (570)	500	13.8 (30.4)	86 (76.1)
D081	AKD-X00606	217 (8.55)	15.9 (141)	45.0 (398)	500	17.9 (39.4)	144 (127)
D082	AKD-X00606	217 (8.55)	25.9 (229)	92.2 (816)	300	21.5 (47.3)	194 (172)
D083	AKD-X00606	217 (8.55)	50.4 (446)	160 (1420)	250	28.8 (63.4)	301 (266)
D101	AKD-X00606	280 (11.0)	34.6 (306)	129 (1140)	300	31.5 (69.3)	693 (613)
D102	AKD-X00606	280 (11.0)	63.4 (561)	227 (2010)	200	43.8 (96.4)	992 (878)
D103	AKD-X01206	280 (11.0)	115 (1020)	501 (4430)	120	60.8 (134)	1750 (1550)
D141	AKD-X01206	362 (14.2)	108 (956)	367 (3250)	200	59.4 (131)	1630 (1440)
D142	AKD-X01206	362 (14.2)	183 (1620)	519 (4590)	120	86.6 (191)	2740 (2430)
D143	AKD-X02406	362 (14.2)	339 (3000)	1340 (11,900)	60	146 (321)	5420 (4800)

400/480 Vac Performance Data

Housed DDR Motor	AKD Servo Drive	Frame Size mm (in)	Continuous Torque Nm (lb-in)	Peak Torque Nm (lb-in)	Maximum Speed RPM	Weight kg (lb)	Inertia (Jm) cm ² (lb-in-s ² x10 ⁻³)
DH061	AKD-X00607	175 (6.90)	5.3 (46.9)	16.9 (150)	800	9.4 (20.7)	61 (54.0)
DH062	AKD-X00607	175 (6.90)	9.8 (86.7)	33.5 (296)	800	11.3 (24.9)	71 (62.8)
DH063	AKD-X00607	175 (6.90)	17.7 (157)	64.4 (570)	800	13.8 (30.4)	86 (76.1)
DH081	AKD-X00607	217 (8.55)	15.9 (141)	45.0 (398)	500	17.9 (39.4)	144 (127)
DH082	AKD-X00607	217 (8.55)	25.9 (229)	92.2 (816)	500	21.5 (47.3)	194 (172)
DH083	AKD-X00607	217 (8.55)	50.4 (446)	160 (1420)	500	28.8 (63.4)	301 (266)
DH101	AKD-X00607	280 (11.0)	34.6 (306)	129 (1140)	300	31.5 (69.3)	693 (613)
DH102	AKD-X00607	280 (11.0)	63.4 (561)	227 (2010)	300	43.8 (96.4)	992 (878)
DH103	AKD-X01207	280 (11.0)	115 (1020)	501 (4430)	250	60.8 (134)	1750 (1550)
DH141	AKD-X01207	362 (14.2)	108 (956)	367 (3250)	300	59.4 (131)	1630 (1440)
DH142	AKD-X01207	362 (14.2)	183 (1620)	519 (4590)	300	86.6 (191)	2740 (2430)
DH143	AKD-X02407	362 (14.2)	339 (3000)	1340 (11,900)	120	146.0 (321)	5420 (4800)

Dimensions

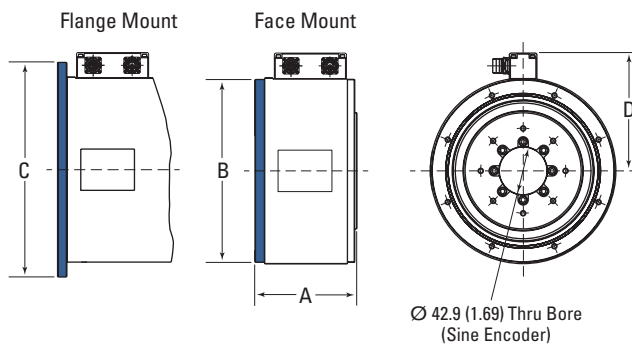

DDR	A mm (in)	B mm (in)	C mm (in)	D mm (in)
D(H)061	130 (5.12)	175 (6.90)	220 (8.66)	126 (4.95)
D(H)062	140 (5.55)	175 (6.90)	220 (8.66)	126 (4.95)
D(H)063	164 (6.46)	175 (6.90)	220 (8.66)	126 (4.95)
D(H)081	145 (5.71)	217 (8.55)	260 (10.2)	147 (5.80)
D(H)082	165 (6.50)	217 (8.55)	260 (10.2)	147 (5.80)
D(H)083	206 (8.11)	217 (8.55)	260 (10.2)	147 (5.80)
D(H)101	153 (6.02)	280 (11.0)	330 (13.0)	181 (7.11)
D(H)102	185 (7.28)	280 (11.0)	330 (13.0)	181 (7.11)
D(H)103	248 (9.76)	280 (11.0)	330 (13.0)	181 (7.11)
D(H)141	153 (6.02)	362 (14.2)	406 (16.0)	218 (8.59)
D(H)142	217 (8.52)	362 (14.2)	406 (16.0)	218 (8.59)
D(H)143	344 (13.50)	362 (14.2)	406 (16.0)	218 (8.59)

Note 1: Refer to page 164 for matching cables.

Note 2: For complete AKD and Housed DDR motor model nomenclature, refer to pages 176 and 182 respectively.

Direct Drive Linear (DDL) Motor

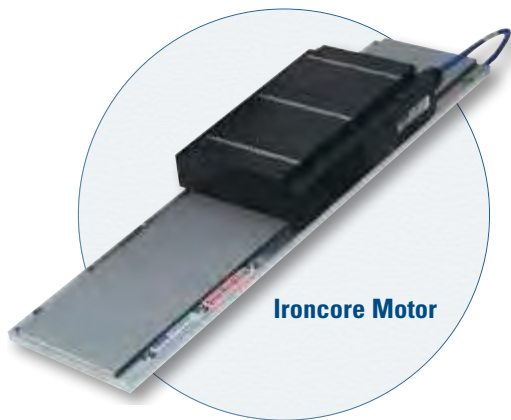

Ironcore Motor



Ironless Motor

Direct Drive Linear Motor Options

Two types of linear motors are available, **Ironcore** and **Ironless**. Each one provides characteristics and features that are optimal depending upon the application. Ironcore motors have coils wound on silicon steel laminations, to maximize the generated force, with a single sided magnet way.

Using a patented electromagnetic design, DDL linear motors have the highest rated force per size, a high K_m motor constant (equals low thermal losses), and low cogging forces without the need for skewing of the magnets. The high thrust forces possible with these motors make them ideal for accelerating and moving high masses, and maintaining stiffness during machining or process forces. Ironless motors have no iron, or slots for the coils to be wound on.

Therefore, these motors have zero cogging, a very light mass, and absolutely no attractive forces between the coil assembly and the magnet way. These characteristics are ideal for applications requiring very low bearing friction, high acceleration of lighter loads, and for maximizing constant velocity, even at ultra low speeds. The modular magnet ways consists of a double row of magnets to maximize the generated thrust force and to provide a flux return path for the magnetic circuit.

Feedback Types

All brushless motors require feedback for commutation. The conventional rotary motor typically utilizes a resolver mounted on the rear of the motor or Hall effect devices mounted integrally in the coil windings. For a linear motor, commutation feedback can also be accomplished with a variety of methods. Digital or linear Hall effect devices are available from Kollmorgen for the DDL motor series which allow the drive electronics to commutate the linear motors in a manner identical to rotary motors.

For exceptionally smooth motion requirements, sinusoidal drive electronics such as the Kollmorgen's AKD series, using digital Hall effects, provide sinusoidal drive currents to the motor for the best constant force and velocity performance. As an alternative, it is typical for linear motor applications to have a linear encoder present in the system for position feedback. It is increasingly common today for drive amplifiers, such as the AKD digital amplifier, to derive the necessary commutation information directly from this linear encoder, either with or without supplemental digital Hall effect devices on startup. Other types of feedback used on linear motor applications include linear Inductosyns, laser interferometers, and LVDT.

Advantages

Wide Speed Range

Since the frameless parts of the linear motor are non-contact, and no limitations of a mechanical transmission are present, both very high speeds and very low speeds are easily obtainable. Speeds are truly not limited by the motor. Instead, by eliminating the mechanical transmission, speed becomes limited by other elements in the system such as the linear bearings, and the achievable bandwidth from any feedback devices. Application speeds of greater than 5 meters per second (200 in./sec.) or less than 1 micron per second (.00004 in./sec.) are typically achievable. In comparison, mechanical transmissions such as ball screws are commonly limited to linear speeds of 0.5 to 0.7 meters per second (20-30 in./sec.) because of resonances and wear. In addition to a wide speed range, linear motors, both ironcore and ironless, have excellent constant velocity characteristics, typically better than $\pm 0.01\%$ speed variation.

High System Dynamics

In addition to high speed capability, direct drive linear motors are capable of very high accelerations. Limited only by the system bearings, accelerations of 3 to 5 G are quite typical for the larger motors and accelerations exceeding 10 G are easily achievable for smaller motors.

Easy Selection process:

1. Determine peak and continuous force required for your applications (see Motioneering Online, page 199, for information about sizing)
2. Use the motor selection guide on pages 84-86 to choose your motor
3. Refer to the appropriate pages in the data publication for technical details
4. Build model number for ordering using pages 78-80 of the Direct Drive Linear Motor Selection Guide

Smooth Operation and Positional Accuracy

Both ironless and ironcore motors exhibit very smooth motion profiles due to the inherent motor design of Kollmorgen's DDL series. Cogging, which is a component of force, is greatly reduced in the ironcore designs and is zero in the ironless designs. As a result, these direct drive linear motors provide very low force and velocity ripple for ultra smooth motion. Positioning accuracies are limited only by the feedback resolution, and sub-micron resolutions are commonly achievable.

Unlimited Travel

With the DDL motor series, magnet ways are made in 5 modular sections: 64 mm, 128 mm, 256 mm, 512 mm and 1024 mm long. Each module can be added in unlimited numbers to any other module to allow for unlimited travel. Whether the travel required is 1mm (0.04 inches) or 100 meters (330 feet), the DDL series can accommodate the need.

No Wear or Maintenance

Linear motors have few components, therefore the need for ball screw components such as nuts, bearing blocks, couplings, motor mounts and the need to maintain these components have been eliminated. Very long life and clean operation, with no lubrication or maintenance of these parts are the result.

Integration of Components is Much Simpler

Frameless linear motors require much fewer components than rotary motors with mechanical transmissions. A 0.8 mm airgap (0.031 inches) for the ironcore design and 0.5 mm airgap (0.020 inches) for the ironless design is the only alignment of the frameless linear motor components that is necessary. No critical alignments are required as with ball screws. Straightness of travel as provided by the system linear bearings is more than sufficient for the Kollmorgen linear motors.

Typical Applications for Linear Motors Include:

- | | |
|------------------------|---------------------------------|
| Machine Tool | Measurement/inspection |
| Drilling | Coordinate measurement machines |
| Milling | Electronic assembly |
| Grinding | Pick-and-place machines |
| Laser cutting | Component insertion |
| Cam grinding | Screen printers |
| Semiconductor | Adhesive dispensers |
| Wafer handling process | PC board inspection, drilling |
| Wafer-inspection | |
| Wafer slicing | Other applications include: |
| Tab bonding | Flight Simulators |
| Wire bonding | Acceleration sleds |
| Ion implantation | Catapult |
| Lithography | G-Force measurement |
| Textile | |
| Carpet tufting | |

Direct Drive Linear (DDL) Motor

SERVO MOTORS
 DIRECT DRIVE LINEAR (DDL) MOTOR

Ironless Linear Motors

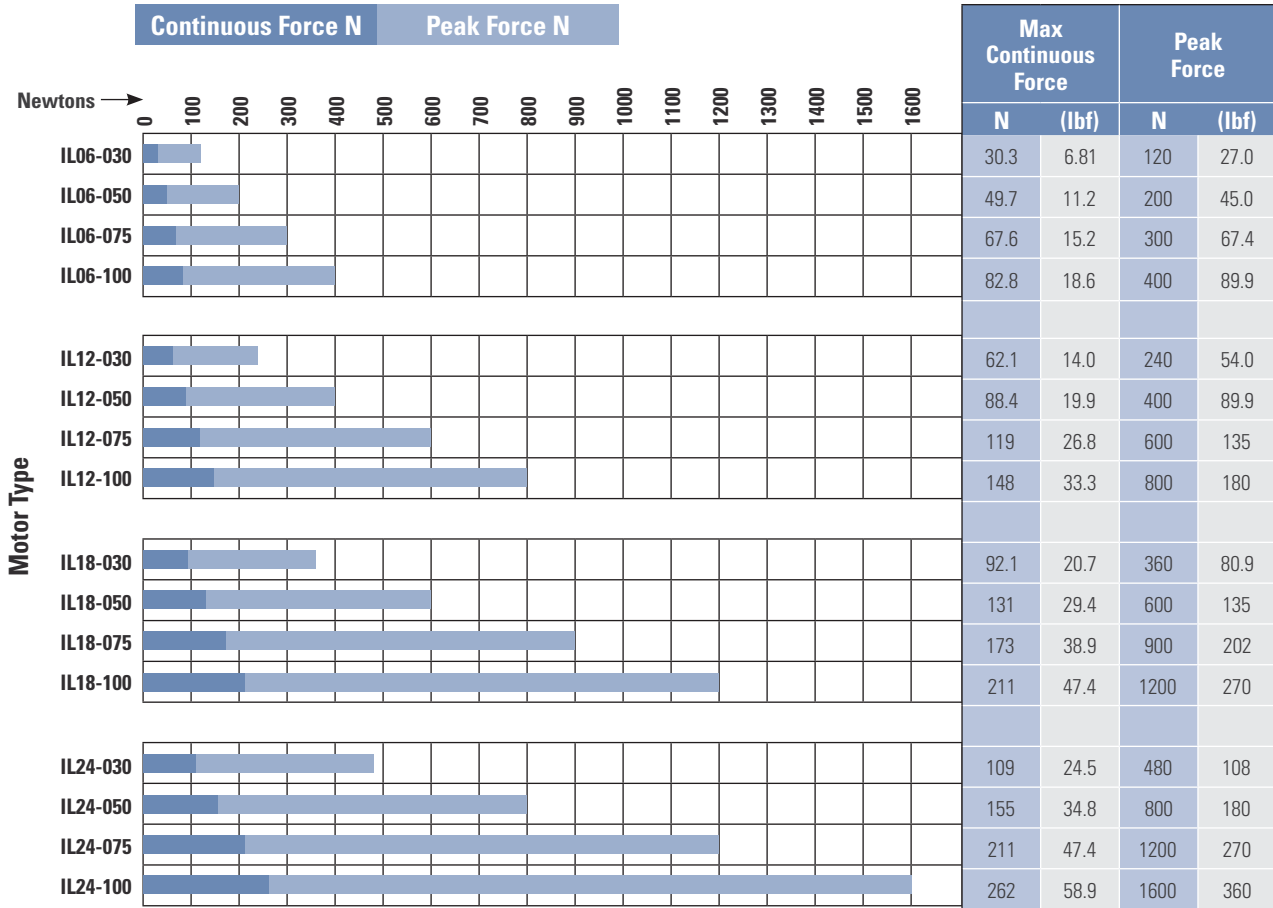

ICD Linear Motors

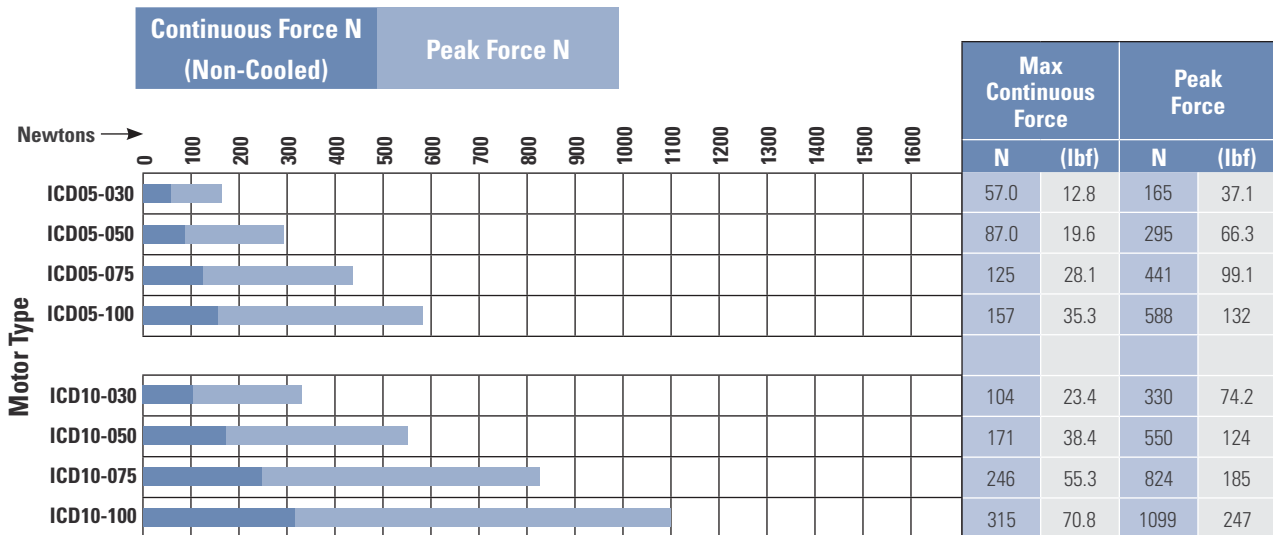

Note: See the DDL Selection Guide for more detailed motor data and dimension drawings.

Ironcore Linear Motors

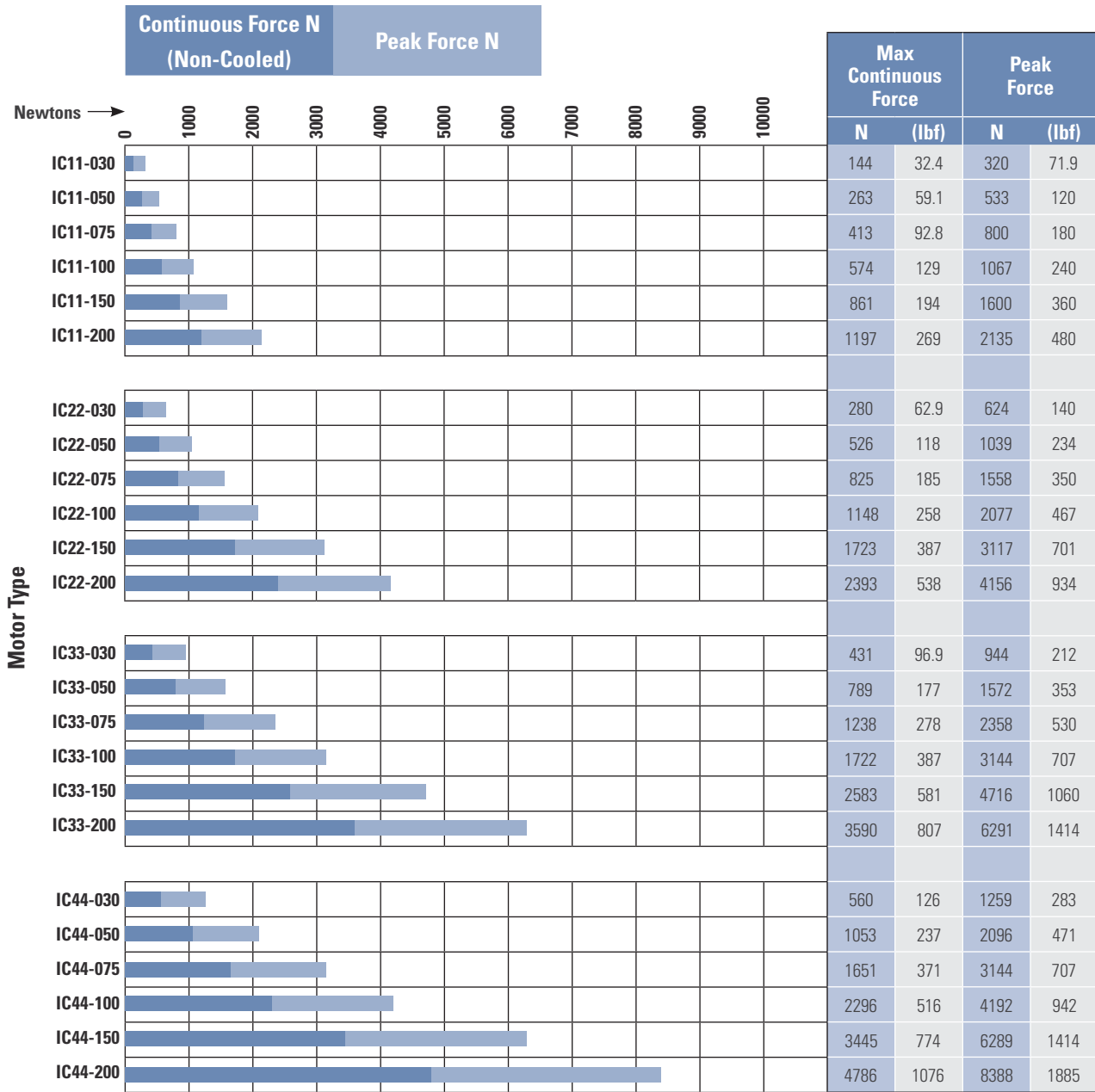

Note: Performance data summarized here represents motor data only. For system performance data with Kollmorgen drives use the Motioneering Application Engine sizing software. See page 199 for more information about Motioneering.

Note: See the DDL Selection Guide for more detailed motor data and dimension drawings.

Direct Drive Linear (DDL) Motor

SERVO MOTORS
 DIRECT DRIVE LINEAR (DDL) MOTOR

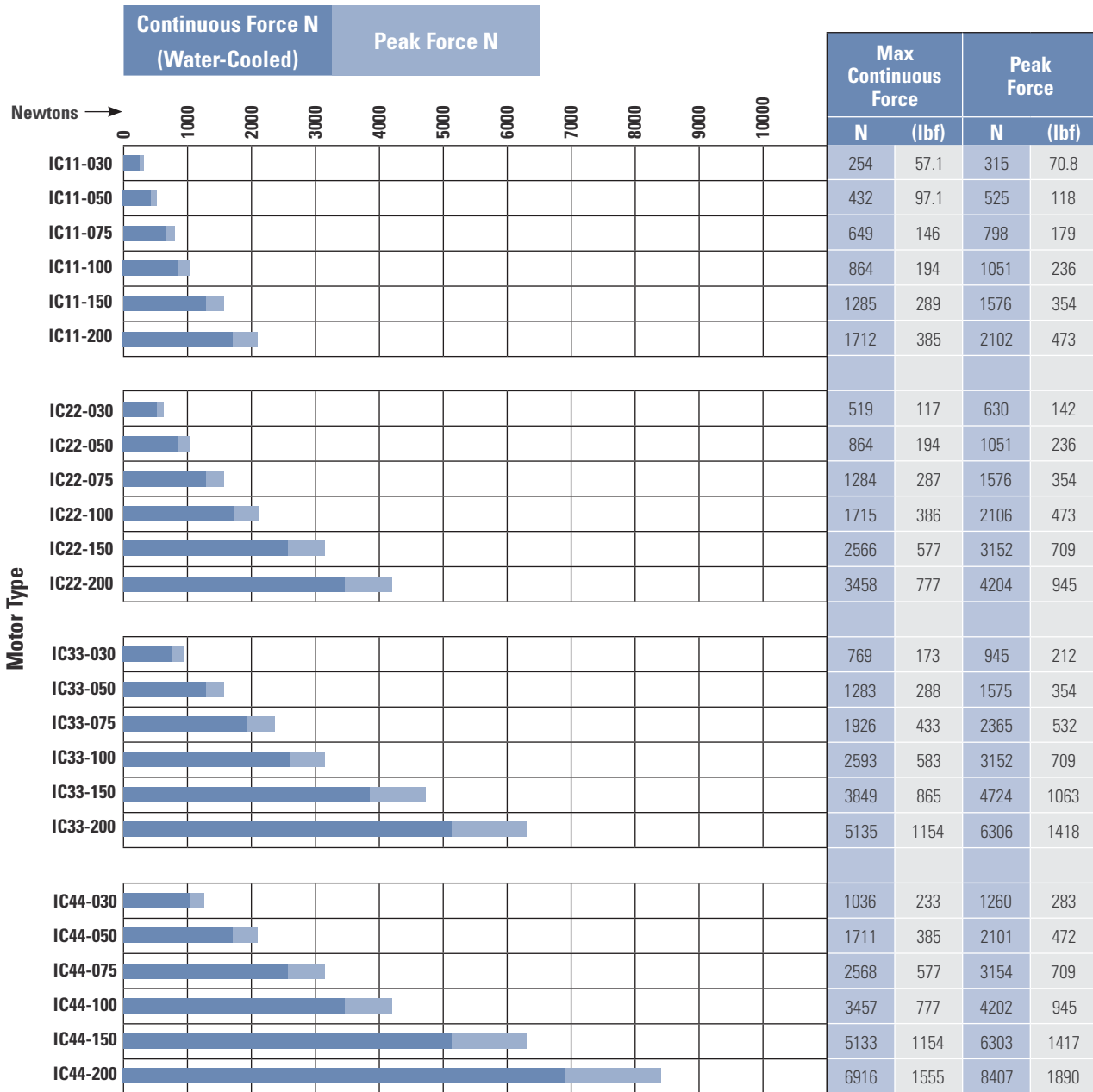

Note: Performance data summarized here represents motor data only. For system performance data with Kollmorgen drives use the Motioneering Application Engine sizing software. See page 199 for more information about Motioneering.

Note: See the DDL Selection Guide for more detailed motor data and dimension drawings.

Notes

A large grid of graph paper for taking notes, consisting of approximately 30 columns and 40 rows of small squares.

KBM Series Frameless Brushless Motor

S E R V O M O T O R S

K B M S E R I E S F R A M E L E S S B R U S H L E S S M O T O R



The KBM frameless motor series is our newest direct drive technology.

KBM frameless brushless motor models are engineered to provide the high-performance, long life and simple installation that today's design engineers demand. Optional latching digital Hall effect sensors are pre-aligned and factory installed with added axial rotor length to achieve proper triggering. Choice of insulation allows operation over a wide range of line input voltage. Our detailed selection guide provides a variety of pre-engineered options and configurations that are currently available.

Custom Application Solutions

For customized features, contact Kollmorgen to help us understand exactly what you need and how we can further optimize any KBM or engineer a new custom motor solution for the unique requirements of your application. We are experts in providing optimized solutions such as special winding configurations, tailored mounting features, diameter and stack length dimensional adjustments, or material variations.

The Benefits of KBM Frameless Motors

- Industry-Leading Frameless Motor Performance
 - Advanced electromagnetic designs deliver maximum torque density which minimizes required motor space envelope
 - Extremely smooth rotation with minimal cogging and low total harmonic distortion (THD)
 - Broad operating speed range and rapid acceleration
- Quality Construction Ensures Reliability and Safe Operation
 - Redundant magnet attachment to rotor on high-speed models – adhesive bonding and high-strength banding
 - 155°C motor winding temperature rating with integral thermistor allows continuous safe operation for demanding applications
 - Designed with UL-recommended insulation systems to simplify system regulatory approval
 - RoHS compliant material selection
 - Compliant with Harmonized Type C Standards EN60034-1:2004 - Rotating Electrical Machines and where appropriate in accordance to the Low Voltage Directive 2006-95-EC
- Highly Configurable Design Minimizes Time to Solution
 - 14 frame sizes with multiple stack lengths
 - Standard sensor feedback using Hall effect sensors
 - Standard high and low voltage insulation
 - Multiple standard windings with custom windings available upon request
 - Mechanical interface changes easily accommodated

KBM Series Overview

Kollmorgen, the global leader in direct drive motor technology, is pleased to offer KBM series frameless brushless motors. With a wide variety of sizes and torque ranges available, KBM models are engineered to provide the high-performance, long life and simple installation that today's design engineers demand.

Quality Construction

- Fully encapsulated stator windings
- 155°C internal winding temperature continuous capability
- PTC thermistor (avalanche-type) overload protection
- High performance magnets
- Fail-safe bands over rotor magnets*
- RoHS compliant

Available Options (No engineering fees apply)

Sensor Feedback (KBMS models)

Latching digital hall effect sensors are pre-aligned and factory installed on the lead end of the stator. Wiring instructions and electrical timing diagrams are included in this selection guide. KBMS models include added axial rotor length to achieve proper sensor triggering.

Choice of Insulation System

S (standard) – acceptable for applications up to 240 Vac drive amplifier supply.

H (high voltage) – required for applications >240 Vac and up to 480 Vac drive amplifier supply.

Allowed Modifications (Engineering fees apply.

Consult Kollmorgen Customer Support for guidance or to obtain a quotation. Unit price increase may apply, depending upon extent of modification.)

Special Windings

Motor windings may be optimized to provide desired speed and torque performance according to the unique voltage and current requirements of a customer's application. Kollmorgen engineers must confirm electrical feasibility and manufacturability of each special winding arrangement prior to quotation.

Special Rotor Hub Dimensions

Rotor hubs may be provided with special customer-designated hole patterns, mounting features or smaller inner bore diameters. Standard KBM(S) models shown within this selection guide include the largest available inner rotor bore diameter.

Rotor Hub Material

Standard configuration KBM(S) rotor hubs are constructed from non-plated cold rolled steel. If special plating, coating, cleaning or alternate material is desired, Kollmorgen engineers must confirm feasibility and pricing adjustment prior to quotation.

Stator Sleeve Material

Standard configuration KBM(S)-10, 14, 17, 25, 35, 45, 163 and 260 size stators are designed with uncoated aluminum sleeves around the stator lamination stack. If special coating or plating is desired for the aluminum stator sleeve, Kollmorgen engineers must confirm feasibility and pricing adjustment prior to quotation. Stator sleeves are only utilized for the sizes listed above.

Agency UL Information

KBM(S) motors are designed to facilitate UL certification in the customer's higher-level assembly. Stator insulation systems are constructed entirely from agency-approved materials and are designed in full compliance with agency creepage and clearance dimensional guidelines. Dielectric strength between winding circuit and grounded metal stator surface is tested at agency-specified voltage level. Because a frameless motor's compliance with agency requirements is dependent upon correct installation and proper design of the surrounding enclosure by the user, KBM(S) series products are not formally labeled or agency-approved at the frameless motor level.

* Does not apply to KBM 163 and KBM 260.

KBM(S) Continuous Torque Overview

Select from our wide variety of sizes and torque ranges to suit your application needs.

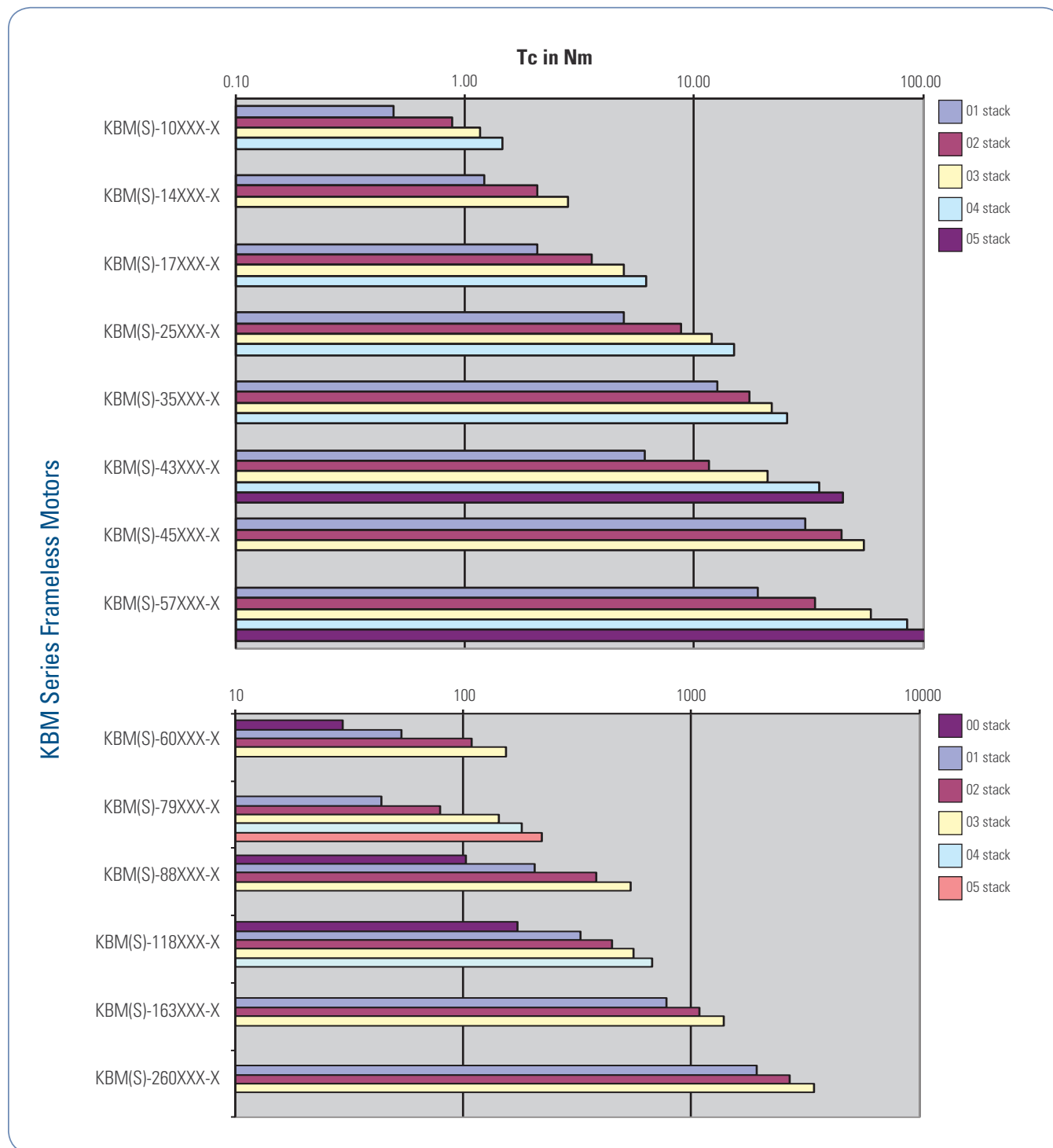

For more detailed information please visit: <http://www.kollmorgen.com/en-us/products/motors/direct-drive/kbm-series-frameless/>

TBM Series Frameless Motors



The TBM frameless motor is a new series of direct drive torque motors designed for applications that require high power in a small, compact form factor with minimized weight and inertia.

Typical applications include robotic joints, weapon stations, sensor gimbals, sight systems, UAV propulsion and guidance, as well as many others.

TBM(S) Product Features

- 3 frame sizes ranging from 60mm (2.36 inches) up to 129mm (5.08 inches)
- 3 stacks lengths per frame
- 2 standard winding options per frame
- Latching Hall Effects (pre-aligned / factory installed)
- Low Cogging designs
- Stainless Steel Yokes for maximum corrosion protection
- RoHS Compliant
- Banded Rotors
- Laser Marked Armatures

For non-standard requests Kollmorgen provides a variety of standard options and configurations.

If higher levels of customization are required, contact Kollmorgen to help us understand exactly what you need.

TBM(S) Continuous Torque Overview

Select from our wide variety of sizes and torque ranges to suit your application needs.

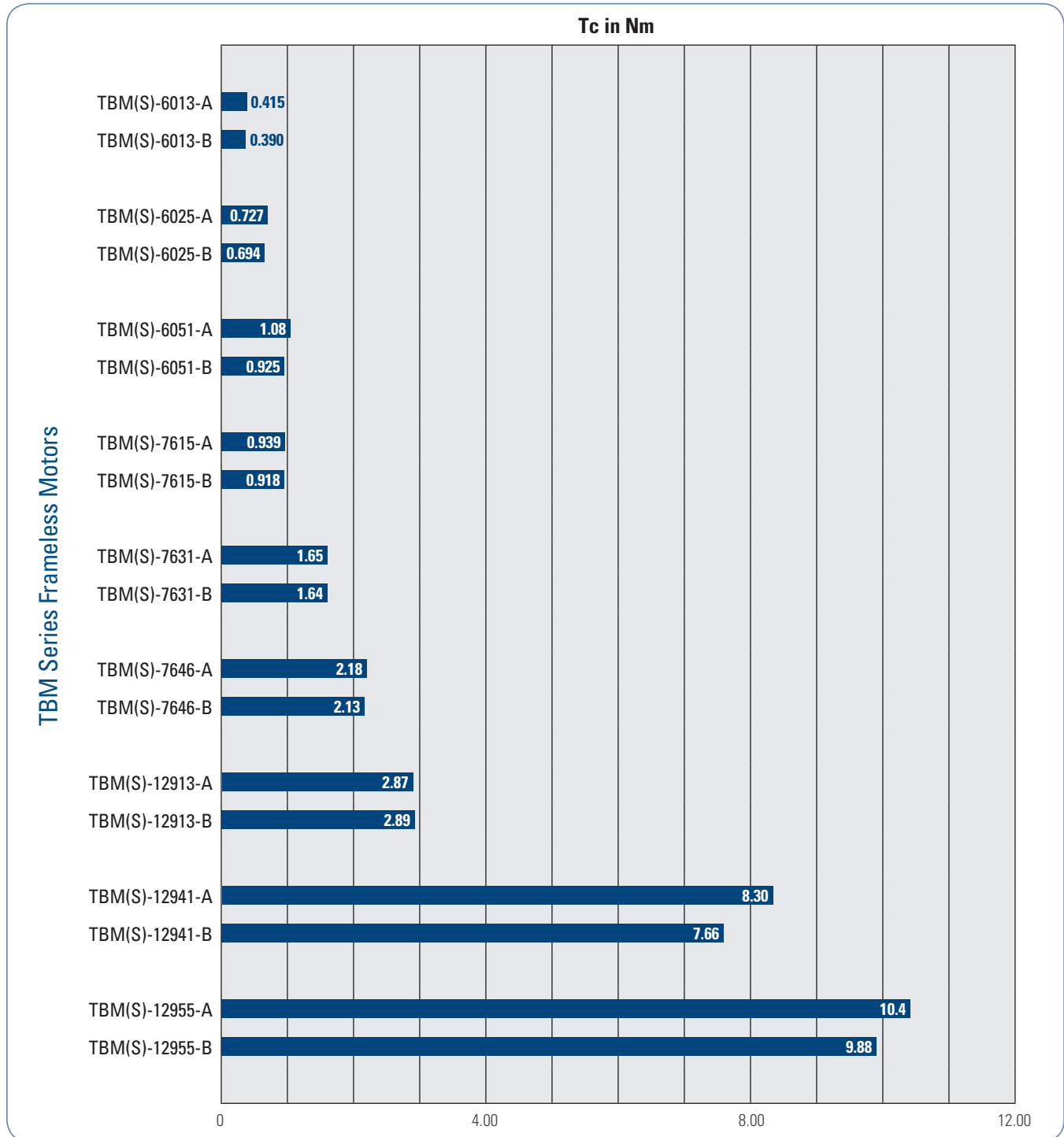

For more detailed information please visit: <http://www.kollmorgen.com/en-us/products/motors/direct-drive/tbm-series/>

Stepper Drives and Motors

Our stepper motors, drives and controllers, which accommodate a wide range of power requirements, provide a high-performance, yet very cost-effective solution when you need precise motion control.

Our hybrid stepper motors are some of the highest torque-density motors in the industry. Available in several NEMA frame sizes, these 2 phase stepper motors inherently move in small, precise 0.9 or 1.8 degree increments (400 or 200 steps/revolution). This stepping action is simple to control and does not require complicated, expensive feedback devices. Our stepper motors are excellent alternatives to pneumatic, hydraulic and servo motor systems.

Kollmorgen's stepper drives are designed with versatility, ease-of-use, and cost-effectiveness in mind. Choose from a broad range of advanced drives and controls including full, half, and microstepping models in both modular and packaged designs.

Kollmorgen's stepper drives and motors are designed with versatility, ease-of-use, and cost-effectiveness in mind. The motors provide high torque in a small package and come in a wide range of standard sizes, constructions, windings and options. They are available with custom leads, shafts and connectors are routinely provided to effectively solve your application needs. Several models feature the addition of our innovative SIGMAX® technology for higher torque and acceleration rates.



P-Series Stepper Drives

Best-in-Class Components

P-Series Stepper Drives work seamlessly with Kollmorgen stepper and synchronous motors for quality, reliability, and performance.

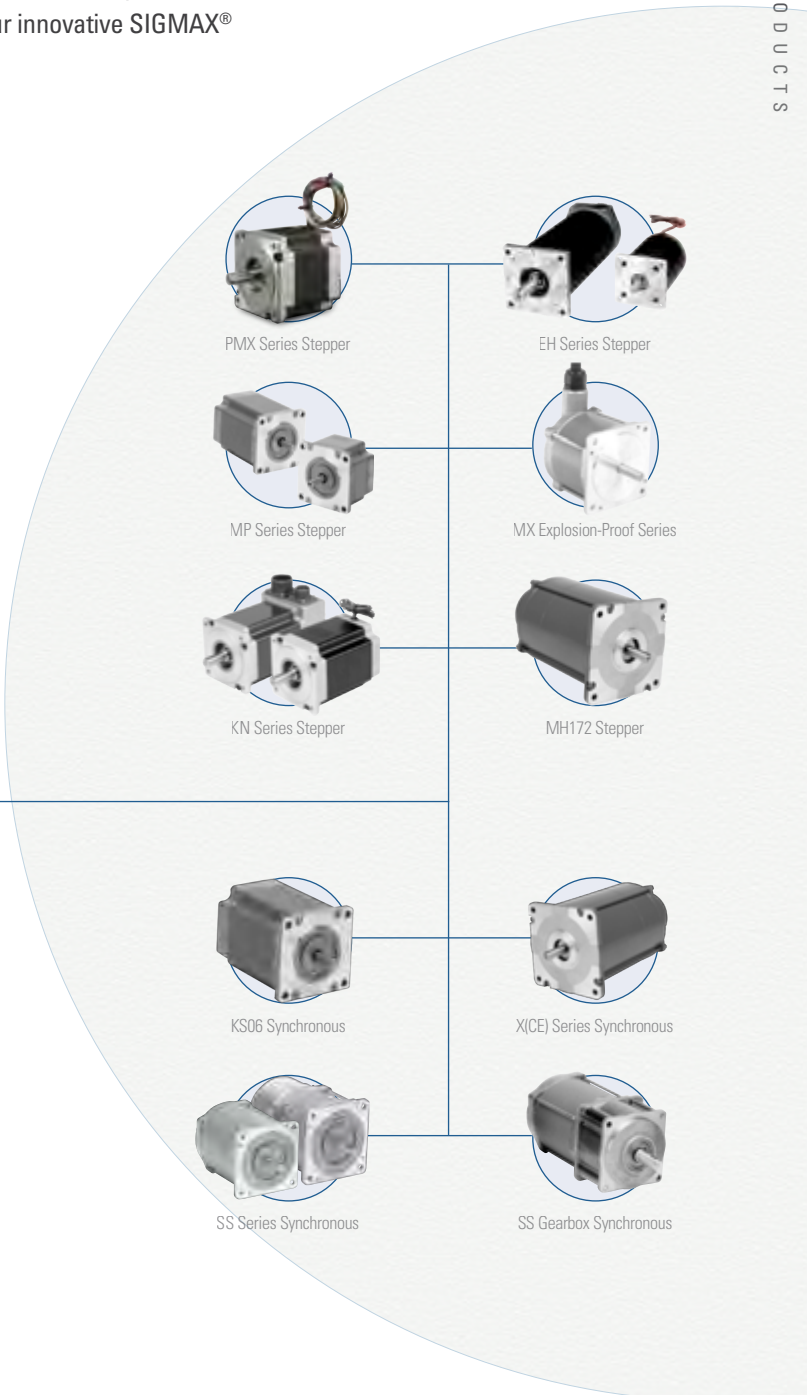

PMX Series Stepper



EH Series Stepper

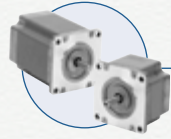

MP Series Stepper



MX Explosion-Proof Series

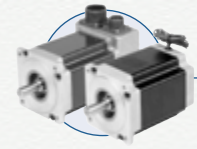

KN Series Stepper

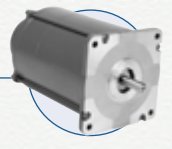

MH172 Stepper

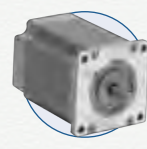

KS06 Synchronous

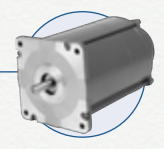

X(CE) Series Synchronous



SS Series Synchronous

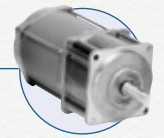

SS Gearbox Synchronous

P-Series Drive Features and Benefits

P5000



Value DC Input Stepper Drive

- Wave matching for Kollmorgen motors to provide optimal performance
- All inputs and outputs are optically isolated
- Step and direction inputs or internal velocity controlled oscillator (VCO) dip switch selectable
- DIP switch selectable micro-stepping resolution settings
- Idle current reduction, DIP switch selectable
- Compensation for mid-range instability
- RoHS & CE certified
- UL pending

P6000



Full Featured AC Input Stepper Drive

- No programming required
- Covers full power range of Kollmorgen steppers
- Switch selectable current from 0.2-5.7 Arms, 8.0 A peak
- Switch selectable for many Kollmorgen motor pairings
- All inputs and outputs are optically isolated
- Single-ended and differential step and direction
- Enable input
- Switch selectable micro-stepping resolution
- Anti-resonance based on load inertia
- RoHS & CE certified

P7000



Full Featured AC or DC Input Stepper Drives with Intelligent Indexing Option (-PN)

- AC and DC input versions
- Covers full power range of Kollmorgen steppers
- Drives can be configured by either dip switches or P7000 software
- Intelligent indexing option (-PN) provides ability to link motion tasks.
- All inputs and outputs are optically isolated
- Single-ended and differential step and direction
- Enable input
- Switch selectable micro-stepping resolution
- Anti-resonance based on load inertia
- RoHS, CE and UL certified

Budget/Value

Full-Featured

STEPPER DRIVE PRODUCT OVERVIEW

Stepper Drive Model	Modes of Operation*	Input voltage (Vdc)	Input Voltage (Vac)	Output current (Adc) Continuous (Peak)
P5000	S, V	20 - 75	n/a	0.7 - 2.0 (3.5)
P6000	S	n/a	110-240 +/-10%	0.3 - 5.7 (8.0)
P70530	S, M	20 - 75	n/a	0 - 5.0 (7.1)
P70360	S, M	n/a	120/240	0 - 2.5 (3.5)

Modes of Operation: S - Step and Direction; V - Velocity Controlled Oscillator (VCO);
 M - Motion Node Indexing

P5000 Stepper Drive-Controller

Big Performance, Micro Package.

Introducing the New Kollmorgen P5000 Stepper Drive.

The P5000 is a compact micro-stepping stepper drive optimized for high system performance with Kollmorgen's industry leading POWERMAX II stepper motors. It is an impressive yet simple addition to the Kollmorgen stepper drive family.

Optimized. Smooth. Compact.

Pairing a stepper system doesn't get any easier! The P5000 and Kollmorgen stepper motors are meant to be together. With Kollmorgen motor windings optimized for the P5000, all you have to do is set the dip switches for the motor you are paired with and you have a smooth operating system that fully utilizes the potential of your Kollmorgen motor and drive combination!

Features

- Current output from 0.7-3.5 Arms peak; DIP switch selectable in 0.2 Amp increments
- Bus Voltage 20-75 Vdc
- Wave matching for Kollmorgen motors to provide optimal performance for the Kollmorgen Stepper Motor Families.
- All Inputs and Outputs are Optically Isolated
- Command Source from External Step and Direction Inputs or Internal Velocity Controlled Oscillator (VCO); DIP switch selectable
- External Single-Ended Step and Direction Command
 - Disable or Fault Reset Input
 - Fault or Enable Output
- VCO Mode
 - CW Limit Input
 - CCW Limit Input
 - Run/Stop Input
 - Run/Stop Output
 - CW Speed trimpot
 - CCW Speed trimpot
 - Accel/Decel trimpot
- DIP switch selectable micro-stepping-resolution settings
- Pulse Multiplier smooths micro-stepping*
- Idle Current Reduction; DIP switch selectable
- Compensation for mid-range instability*
- RoHS & CE certified
- UL pending



P5000 Stepper Drive
(Shown Actual Size)



Note: For complete P-Series model nomenclature, refer to page 184.
*Patents Pending

P6000 Stepper Drive-Controller

Powerful, Yet Simple.

Introducing the New Kollmorgen P6000 Stepper Drive.

The P6000 is an AC input micro-stepping drive optimized for pairing with POWERPAC and POWERMAX stepper motors. With the simplicity of dip switches and the optimized performance from the complete system, this stepper solution brings increased machine performance without the associated complexity.

Powerful. Simple. Optimized.

The P6000 and Kollmorgen POWERPAC and POWERMAX stepper motors are designed to provide the best system solution when paired with one another. The easy dip switch selection matches the P6000 settings with the optimal Kollmorgen stepper motor requirements to provide the best performance and most efficient solution for nearly any application.

Features

- No programming required!
- Covers full power range of Kollmorgen Stepper Motors
- Switch Selectable Current Output from 0.2-5.7 Arms, 8.0 A peak
- 120/240 VAC Input (160/320 Vdc Bus)
- Kollmorgen Stepper Motor Pairing; Switch Selectable
- All Inputs and Outputs are Optically Isolated
- Single-Ended and Differential Step and Direction or CW/CCW Command; Switch Selectable
- Enable Input
- Fault Output (Sinking or Sourcing)
- Status LEDs for easy troubleshooting
- Switch Selectable Micro-Stepping-Resolution Settings
- Step Smoothing Filter; Switch Selectable
- Idle Current Reduction; Switch Selectable
- Anti-Resonance Based On Load Inertia; Switch Selectable
- Self-Test Conducts Spin Test to Confirm Proper Connection; Switch Selectable
- RoHS & CE Certified



P6000 Stepper Drive



Note: For complete P-Series model nomenclature, refer to page 184.

P7000 Stepper Drive-Controller

P7000 stepper drives offer a unique level of system functionality, smoothness, high-speed performance and innovation unmatched in the industry.

The compact P7000 is designed to power Kollmorgen step motors ranging from NEMA size 17 up to NEMA size 42. Two power configurations are available for operation directly from AC power, or from a DC power supply.

There are two levels of control offered. The basic drive accepts step and direction inputs. P7000 drives are also available with an integrated position controller (-PN option). The drives are configured by either on-board dip switches, or with the P7000 tools software.



Advanced P7000 Features Make it the Best Choice to Meet Your Application Requirements

Multisteping™

Also known as auto-smoothing. The P7000 drive accepts full step pulse commands from the indexer and inserts fine micro-steps to smooth coarse low speed motion. This allows you to significantly upgrade machine performance without having to redesign machine control architecture.

Auto-Tuning

Advanced current auto-tuning techniques provide outstanding low-speed smoothness. The P7000 senses the motor's characteristics and automatically fine tunes itself to meet your high-performance needs. This reduces installation and set-up time.

Mid-Band Anti-Resonance Control

Reduces negative effects of mechanical resonance, allowing you to get more out of a smaller motor and virtually eliminating nuisance stalls and machine downtime.

Idle Current Reduction

If you do not require the motor's full torque to hold a load at rest, you can select the right amount of current (torque) to reduce motor heating and power consumption. This increases the life of the system.

Dynamic Smoothing

Quasi-S-curve algorithm reduces jerk, especially upon acceleration. Increases mechanical life of the machine and reduces energy consumption.

Intelligent Indexing Option (-PN)

Wizard-like P7000 helps you to develop and link motion tasks such as homing and conditional and unconditional indexing. You can be up-and-running quickly.

Modbus RTU Compatible

The intelligent indexing option (-PN) supports Modbus RTU to control motion with an external interface device. External interfaces make controlling motion simple for machine operators.

P7000 Tools

The position node option allows you to configure up to 63 absolute or relative moves. You can specify the moves' distance, acceleration, velocity, and deceleration rates, or simply specify the distance and total time for the move – P7000 will perform the calculations automatically.

Specifications	Units	P70530	P70360
Input voltage range	Volts	20 - 75 Vdc	120 or 240 Vac
Continuous current	Amps rms	5	2.5
Microstep peak current	Amps peak	7.1	3.5



Note: For complete P-Series model nomenclature, refer to page 184.

Stepper Motor Overview

Kollmorgen offers a comprehensive range of stepper motor products including continuous torque, high torque and hybrid options to meet a wide range of application requirements. For other Kollmorgen stepper products or information not included in this catalog go to www.kollmorgen.com.

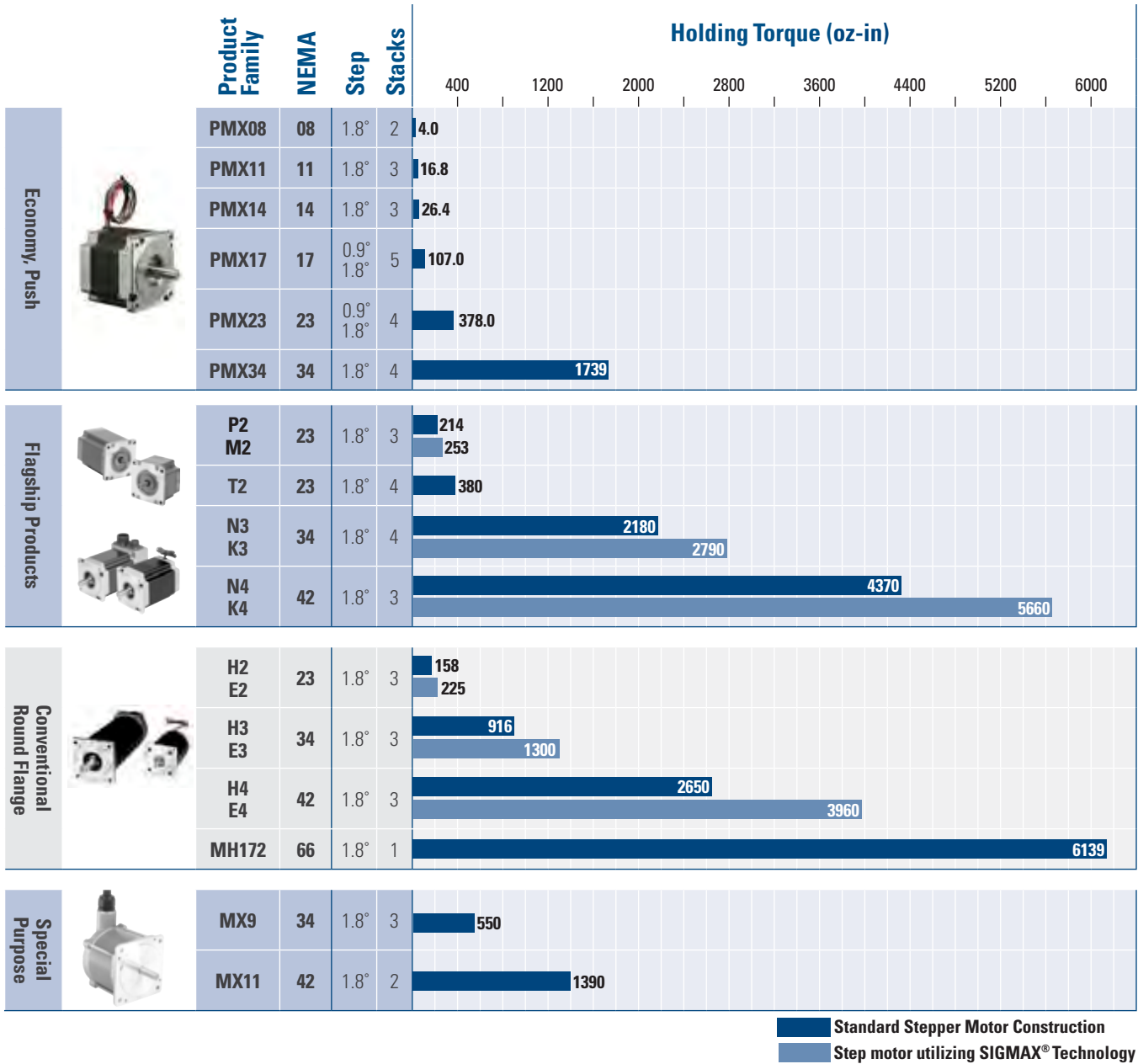

 Standard Stepper Motor Construction
 Step motor utilizing SIGMAX® Technology

Product Family	NEMA	Features				Standard Options											Family Features		
		UL Recognized	CE Mark	RoHS	SIGMAX® Technology	Integral Connectoin	Leadwire	4-Lead Bipolar	6-Lead Unipolar	8-Lead	Terminal Box	MS Connector	IP Sealing	Encoders	Front Shaft			Rear Shaft	Low Inertia
○ available option																			
PMX08	08		•	•			•	•						30	○	•	•		<ul style="list-style-type: none"> NEMA Sizes 8, 11, 14, 17, 23, 34 CE, RoHS, and REACH Compliant Unipolar or Bipolar windings Options: shaft flats, rear shaft with encoder mounting holes, IP Sealing Special Options readily available: spur and planetary gearboxes, encoders, special shafts
PMX11	11		•	•			•	•						30	○	•	•		
PMX14	14		•	•			•	•						30	○	•	•		
PMX17	17		•	•		•	•	•	○					30	○	•	•		
PMX23	23		•	•		•	•	•	○					30, 65 ¹	○	•	•		
PMX34	34		•	•		•	•							30, 65 ¹	○	•	○	•	
P2 M2	23	• •	• •		•	• •			•					40 40	• •	• •	○ ○	• •	<ul style="list-style-type: none"> High torque standard hybrid stepper motor Enhanced M and K SIGMAX models provide up to 25% more torque in same package Low detent torque for smoother microstepping Bipolar and unipolar winding Large array of options
T2	23	•	•			•	•	•		•	•			40	•	•	○	•	
K3 N3	34	• •	• •		•	• •	• •	• •	• •	• •	• •			65 ¹ 65 ¹	• •			• •	
K4 N4	42	• •	• •		•	• •	• •	• •	• •	• •	• •			65 ¹ 65 ¹	• •			• •	
H2 E2	23	• •	• •		•	• •	• •	• •	• •		•			40 40	• •	• •	○ ○	• •	<ul style="list-style-type: none"> High efficiency, low loss hybrid designs in a conventional round frame Enhanced E SIGMAX models provide up to 25% more torque in the same package Torque produced over a wide speed range Large array of options E2, H2 offer high axial loading
H3 E3	34	• •	• •		•	• •	• •	• •		•				65 ¹ 65 ¹	• •	• •	○ ○	• •	
H4 E4	42	• •	• •		•	• •	• •	• •		•				65 ² 65 ²	• •			• •	
MH172	66									•				40	•			•	
MX9	34	•												40	•			•	<ul style="list-style-type: none"> Standard hybrid stepper motor Meets Explosion proof UL Class 1, Division 1 Group D requirements Up to 150% rated torque reserve capacity (MX9) and 200% for {MX11}
MX11	42	•												40		•		•	

Notes: 1. Requires shaft seal and connection option other than leaded (Meets IP40 otherwise)
 2. Requires shaft seal option (Meets IP40 otherwise)

Hybrid PMX Step Motor

Kollmorgen's new PMX™ stepper motor line delivers breadth and design flexibility at competitive lead times.

Kollmorgen is excited to continue its winning heritage in hybrid stepper motors by introducing the PMX family. Leveraging the best practices from customer preferred products in the POWERMAX and POWERPAC families, the PMX lines will deliver breadth and design flexibility at a very competitive lead time. Look no further for that hybrid stepper motor family with local support that gives you the flexibility you need to succeed.

PMX Series motors include smaller Nema 08, 11, and 14 frame sizes in addition to the traditional Nema 17, 23, and 34 frame sizes. Each frame size is built with high quality construction in an affordable, market competitive solution. Numerous co-engineering options are also available including: customizing shafts, encoders, and mounted spur and planetary gearboxes.

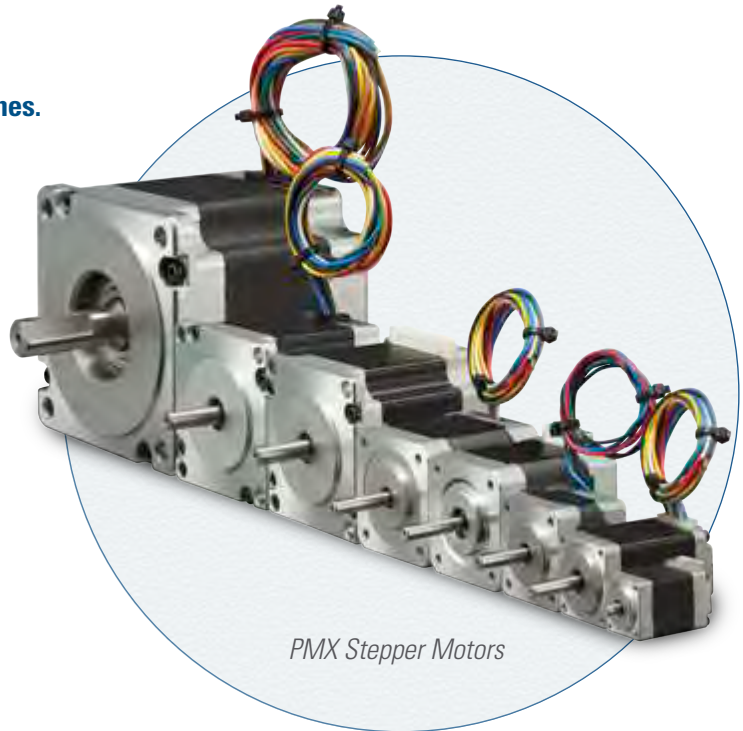

PMX Stepper Motors

- **Increased Design Flexibility** – six frame sizes (08, 11, 14, 17, 23, 34) each with several stack length and winding options available
- **Minimal Drive Adjustments** – options for 1.8 and 0.9 degree step angles
- **Lower Unit Cost** – PMX motors are priced competitively in today's current stepper market and are the lowest of all Kollmorgen stepper products.
- **Quality construction** translates to reliability in the field and a long service life.
- **Localized Support** gives you the delivery terms and immediate technical support you need, meaning to quicker time to market and less downtime.
- **Flexible Manufacturing** enables Kollmorgen to immediately evaluate modifications and co-engineered solutions for rapid prototyping
- **Easy to Apply Worldwide** – CE, RoHS, REACH

Many Applications

PMX motors allow Kollmorgen customers to fulfil their automation needs at an affordable cost, enabling higher throughput in a wide variety of equipment. In addition, leveraging Kollmorgen's technical expertise and flexible engineering, the PMX is ready for seamless special and co-engineering options, allowing for swifter and easier integration into both new and existing applications.

PMX Stepper Motor General Specifications



	Series	Stacks	Holding Torque (Motor Mounted)		Length		Features
			Bipolar		in	mm	
			oz-in	Nm			
Size 08 PMX Series 	2 Phase, 1.8° Step Motors. Frame size: 0.8 inch, 20 mm						
	PMX081	1	2.50	0.018	1.18	30.0	<ul style="list-style-type: none"> • Front shaft flat option • Rear shaft option
	PMX082	2	4.00	0.028	1.65	42.0	
Size 11 PMX Series 	2 Phase, 1.8° Step Motors. Frame size: 1.1 inch, 28 mm						
	PMX111	1	10.1	0.071	1.26	32.0	<ul style="list-style-type: none"> • Front shaft flat option • Rear shaft option • Integral connector option
	PMX112	2	16.1	0.114	1.77	45.0	
PMX113	3	16.8	0.119	2.01	51.0		
Size 14 PMX Series 	2 Phase, 1.8° Step Motors. Frame size: 1.4 inch, 35 mm						
	PMX141	1	14.7	0.104	1.02	26.0	<ul style="list-style-type: none"> • Front shaft flat option • Rear shaft option • Rear encoder mounting holes
	PMX142	2	20.1	0.142	1.10	28.0	
PMX143	3	26.4	0.186	1.42	36.0		
Size 17 PMX Series 	2 Phase, 0.9° or 1.8° Step Motors. Frame size: 1.7 inch, 42 mm						
	PMX171 (1.8)	1	28.4	0.201	1.02	26.0	<ul style="list-style-type: none"> • Front shaft flat option • Rear shaft option • Integral connector option • Bipolar or Unipolar winding available • Rear encoder mounting holes
	PMX172 (1.8)	2	40	0.281	1.32	33.5	
	PMX173 (1.8)	3	61	0.427	1.56	39.5	
	PMX174 (1.8)	4	78	0.551	1.87	47.5	
PMX171 (1.8)	5	107	0.756	2.36	60.0		
Size 23 PMX Series 	2 Phase, 0.9° or 1.8° Step Motors. Frame size: 2.2 inch, 57 mm						
	PMX231 (1.8)	1	102	0.722	1.61	41.0	<ul style="list-style-type: none"> • Front shaft flat option • Bipolar or Unipolar winding available • Rear shaft option • Integral connector option • Option for IP65 sealing • Rear encoder mounting holes
	PMX232 (1.8)	2	208	1.47	2.20	56.0	
	PMX233 (1.8)	3	337	2.38	2.99	76.0	
PMX234 (1.8)	4	378	2.67	3.35	85.0		
Size 34 PMX Series 	2 Phase, 1.8° Step Motors. Frame size: 3.4 inch, 86 mm						
	PMX341	1	490	3.46	2.56	65.0	<ul style="list-style-type: none"> • Front shaft flat option • Rear shaft option • Option for IP65 sealing
	PMX342	2	704	4.97	3.15	80.0	
	PMX343	3	1285	9.07	4.65	118.0	
PM344	4	1739	12.28	6.14	156.0		

Note: For complete PMX series model nomenclature, refer to page 185.

AC Synchronous Motor Overview

Kollmorgen offers a comprehensive range of AC synchronous motor products including continuous torque, high torque and hybrid options to meet a wide range of application requirements. For products not included in this catalog go to www.kollmorgen.com for information about other Kollmorgen synchronous motor products.

Flagship Products

	Product Family	Page No.	NEMA	Torque (oz-in)										
				200	400	600	800	1000	1200	1400	1600			
High Torque, Feature Rich 	KS06	110	23	80 – 185										
	SS240, 450	112	34	240 – 450										
	SS150, 250, 400, 700	112	42	150 – 700										
	SS1800	112	66	700 – 1800										
Special Purpose 	X(CE)250, 700	118	42	250 – 700										
	X(CE)1100, 1500	118	66	1100 – 1500										
Gearmotor 	SS24x, 45x Gearmotor	122	34	630 – 5000										

STEPPER PRODUCTS AC SYNCHRONOUS MOTOR

Product Family	Page No.	NEMA	Phases	Options			Family Features
				Leaded	Terminal Box	Rear Shaft	
KS06	110	23	1Ø	•	•	•	<ul style="list-style-type: none"> • 1Ø and 3Ø (SS240, 450 models only) • 72 rpm motor speed (with 60 Hz voltage) • 60 rpm motor speed (with 50 Hz voltage) • 120 volt or 240 volt AC models • Torques: 80 – 1800 oz-in (0.56 – 12.7 Nm) • Fast starting, stopping, or reversing • Can be stalled indefinitely without overheating
SS240, 450	112	34	3Ø	•	•	•	
SS150, 250,400, 700	112	42	1Ø	•	•	•	
SS1800	112	66	1Ø	•	•	•	
X(CE)250, 700	118	42	1Ø	•		•	<ul style="list-style-type: none"> • 1Ø models • X models meet UL Class 1, Group D requirements • XCE models meet ATEX CE 0081 G Exd IIC T5 Gb reqmt. • 60 and 50 Hz models (72 and 60 rpm respectively) • 120 volt or 240 volt AC models • Torques: 250 – 1500 oz-in (1.77 – 10.6 Nm) • Fast starting, stopping, or reversing • Can be stalled indefinitely without overheating
X(CE)1100, 1500	118	66	1Ø	•		•	
SS240, 450 Gearmotor	122	34	3Ø	•	•	•	<ul style="list-style-type: none"> • All the features of the SS240, 450 series • Gear reducers with ratios up to 125:1 • Torques: 634 - 5000 oz-in (4.48 – 35.3 Nm)

Micron™ TRUE Planetary™ Gearbox

Planetary Gearbox Technology

Helical gears are known for their quiet and smooth operation along with their ability to transmit higher loads than spur gears. Both of these features of helical gearing result from the improved contact ratio (effective teeth in mesh) over spur gears.

A high torque, whisper quiet helical gearbox has been designed by combining the positive attributes of gear crowning and helical gearing with the planetary construction to create the smoothest operating gearbox on the market.

- Broadest product range of gearboxes in the industry
- Innovative gear technology offers size and performance advantages
- RediMount™ system provides error-free and reliable installations

Helical Crowned TRUE Planetary™ Gearing

Features

- High torque capacity
- Low backlash
- Smooth operation
- Greater load sharing
- Whisper quiet

Spur vs. Helical Gearing

Typical contact ratio is 1.5 for spur gearing. Contact ratio for equivalent helical gear is 3.3 – more than double the contact ratio.

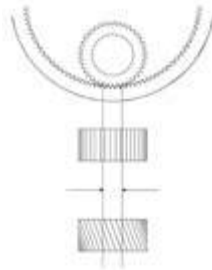

Crowned vs. Non-Crowned

Crowning optimizes the gear mesh alignment within a gear train to increase the torque capacity and reduce noise. It also enhances load distribution on the tooth flank to reduce high stress regions.

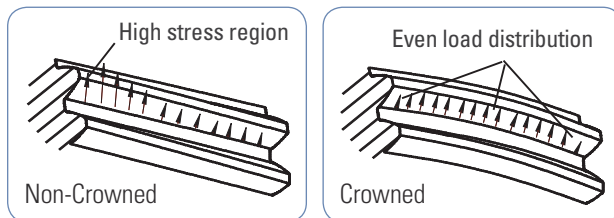

PowerTRUE™ Right Angle Gearboxes

- Lower backlash from single axis mesh adjustment
- A compact design using face gear technology
- Whisper quiet operation due to high contact ratio
- Mesh ratios from 1:1 to 5:1
- Extremely efficient (98%)



PowerTRUE™ gear technology



Computerized mapping of gear tooth profile



All Micron right angle gearboxes use the PowerTRUE technology which increases the mesh ratio to 5:1 compared to a maximum of 3:1 typical in bevel gears.

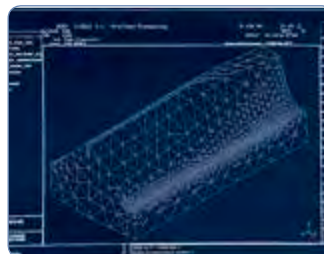

Multiple teeth in the face gear simultaneously mesh with a standard involute pinion. The continuous tooth engagement yields a high contact ratio between the gear and the pinion, increasing torque and efficiency.

NEMA TRUE™		True planetary gearbox, flange mount design with anodized aluminum housing employing RediMount™ system.							
Inline	Frame Size		Max T Peak (lb-in)		All Sizes	Gear Ratios Available	Efficiency	Backlash (arc-min)	
	English	Metric	1 Stage	2 Stage					
Size 17	NEMA 17	42 mm	170	170	1 Stage	3, 4, 5, 7, 10	93%	13 (8)*	
Size 23 / 60	NEMA 23	60 mm	250	275					
Size 34 / 90	NEMA 34	90 mm	700	850	2 Stage	15, 20, 25, 30, 40, 50, 70, 100	88%	15 (9)*	
Size 42 / 115	NEMA 42	115 mm	1000	1600					



NEMA TRUE™		True planetary gearbox, flange mount design with anodized aluminum housing employing RediMount™ system.							
Right Angle	Frame Size		Max T Peak (lb-in)			All Sizes	Gear Ratios Available	Efficiency	Backlash (arc-min)
	English	Metric	1 Stage	2 Stage	3 Stage				
Size 23 / 60	NEMA 23	60 mm	360	366	366	1 Stage	1, 2, 3, 4, 5P	98%	13
Size 34 / 90	NEMA 34	90 mm	1110	1110	1110	2 Stage	5T, 6, 9, 10, 12, 15, 20, 25, 30, 40, 50	93%	15
Size 42 / 115	NEMA 42	115 mm	2250	2250	2250	3 Stage	60, 75, 90, 100, 120, 125, 150, 200, 250, 300, 400, 500	88%	15



XTRUE™		The XTRUE Series is a new precision gearbox employing RediMount™ system that compliments our TRUE planetary gearbox line – already the largest selection of planetary gearboxes in the world.							
Inline	Frame Size Metric	Max T Peak (lb-in)		All Sizes	Gear Ratios Available	Efficiency	Backlash (arc-min)		
		1 Stage	2 Stage						
XT040	40 mm	162	299	1 Stage	3, 4, 5, 7, 8, 10	93%	13		
XT060	60 mm	483	483						
XT080	80 mm	1460	1550						
XT120	120 mm	2640	2640						
XT160	160 mm	7750	7750						
XTA050	50 mm	162	299	2 Stage	15, 20, 25, 30, 40, 50, 70, 80, 100	88%	15		
XTA070	70 mm	483	483						
XTA090	90 mm	1460	1552						
XTA120	120 mm	2639	2639						



EverTRUE™		EverTRUE, employing RediMount™ system, is specifically designed for 24/7 continuous running applications providing 3 times (30,000 hours) service life.							
Inline	Frame Size Metric	Max T Peak (lb-in)		All Sizes	Gear Ratios Available	Efficiency	Backlash (arc-min)		
		1 Stage	2 Stage						
ET010	101 mm	4093	4794	1 Stage	4, 5, 7, 10	95%	4		
ET014	141 mm	9430	11,250						
ET018	182 mm	21,600	26,280	2 Stage	16, 20, 25, 28, 35, 40, 50, 70, 100	90%	5		





Note 1: Torque capacity is maximum of frame size stage design, not all ratios have the same rated torque capacity.
 Note 2: Torque capacity is the maximum allowable momentary torque for emergency stopping or heavy shock loading.
 Note 3: Ratio 5P is designed using the compact PowerTrue face gearing technology.
 Note 4: Ratio 5T is designed using a True planetary gear stage for increased torque capacity.
 Note 5: For complete gearbox model nomenclature, refer to page 194.





Micron™ TRUE Planetary™ Gearbox

MICRON™ TRUE PLANETARY™ GEARBOX

DuraTRUE™	True planetary gearbox, flange mount design with anodized aluminum housing employing RediMount™ system.							
	Inline	Frame Size Metric	Max T Peak (lb-in)		All Sizes	Gear Ratios Available	Efficiency	Backlash (arc-min)
			1 Stage	2 Stage				
	DT60	60 mm	460	460	1 Stage	3, 4, 5, 7, 10	93%	8
	DT90	90 mm	1480	1480				
	DT115	115 mm	2513	2513	2 Stage	15, 20, 25, 30, 40, 50, 70, 100	88%	9
	DT142	142 mm	7380	7380				

DuraTRUE™	True planetary right angle gearbox, flange mount design with anodized aluminum housing employing RediMount™ system.							
	Right Angle	Frame Size Metric	Max T Peak (lb-in)		All Sizes	Gear Ratios Available	Efficiency	Backlash (arc-min)
			1 Stage	2 Stage				
	DTR60	60 mm	460	460	1 Stage	5, 6, 9, 10, 12, 15, 20, 25, 30, 40, 50	93%	8
	DTR90	90 mm	1480	1480				
	DTR115	115 mm	2513	2513	2 Stage	60, 75, 90, 100, 120, 125, 150, 200, 250, 300, 400, 500	88%	9
	DTR142	142 mm	7380	7380				

Slimline	Slimline right angle gearbox, flange mount design with anodized aluminum housing employing RediMount™ system. Face gear technology for compact right angle construction. Dual shaft output version also available.								
	Right Angle	Frame Size Metric	Max T Peak (lb-in)			All Sizes	Gear Ratios Available	Efficiency	Backlash (arc-min)
			1 Stage	2 Stage	3 Stage				
	DTR60S	60 mm	400	407	407	1 Stage	1, 2, 3, 4, 5P	98%	8
	DTR90S	90 mm	1237	1237	1237	2 Stage	5T, 6, 9, 10, 12, 15, 20, 25, 30, 40, 50	93%	9
	DTR115S	115 mm	2265	2505	2505	3 Stage	60, 75, 90, 100, 120, 125, 150, 200, 250, 300, 400, 500	88%	9
	DTR142S	142 mm	5500	6917	7450				

Hollow Shaft	Hollow shaft right angle gearbox, flange mount design with anodized aluminum housing employing RediMount™ system. Large diameter/ bolt circle for direct mechanical interface. Face gear technology for compact right angle construction.								
	Right Angle	Frame Size Metric	Max T Peak (lb-in)			All Sizes	Gear Ratios Available	Efficiency	Backlash (arc-min)
			1 Stage	2 Stage	3 Stage				
	DTR90H	90 mm	1237	1237	1237	1 Stage	1, 2, 3, 4, 5P	98%	8
	DTR115H	115 mm	2505	2505	2505	2 Stage	5T, 6, 9, 10, 12, 15, 20, 25, 30, 40, 50	93%	9
	DTR142H	142 mm	7660	7660	7660	3 Stage	60, 75, 90, 100, 120, 125, 150, 200, 250, 300, 400, 500	88%	9

Note 1: Torque Capacity is maximum of frame size stage design, not all ratios have the same rated torque capacity.
 Note 2: Torque Capacity is the maximum allowable momentary torque for emergency stopping or heavy shock loading.
 Note 3: Ratio 5P is designed using the compact PowerTrue face gearing technology.
 Note 4: Ratio 5T is designed using a True planetary gear stage for increased torque capacity.
 Note 5: For complete gearbox model nomenclature, refer to page 194.



ValueTRUE™	Helical True planetary gearbox, flange mount design with stainless steel housing employing RediMount™ system.							
	Inline	Frame Size Metric	Max T Peak (lb-in)		All Sizes	Gear Ratios Available	Efficiency	Backlash (arc-min)
			1 Stage	2 Stage				
	VT006	61 mm	800	910	1 Stage	4, 5, 7, 10	95%	4
	VT075	75 mm	1423	1632				
	VT090	90 mm	1423	1632				
	VT010	101 mm	4093	4794				
	VT115	115 mm	4093	4794	2 Stage	16, 20, 25, 28, 35, 40, 50, 70, 100	90%	5
	VT014	141 mm	9430	11,250				
	VT018	182 mm	21,609	26,287				
	VT022	220 mm	36,986	44,000				

ValueTRUE™	Helical True planetary gearbox, flange mount design with stainless steel housing employing RediMount™ system.							
	Right Angle	Frame Size Metric	Max T Peak (lb-in)		All Sizes*	Gear Ratios Available	Efficiency	Backlash (arc-min)
			1 Stage	2 Stage				
	VTR006	61 mm	876		1 Stage	4, 5, 8, 10, 12, 14, 15, 16, 20, 25, 28, 30, 35, 40, 50	93%	5
	VTR075	75 mm	1570					
	VTR090	90 mm	1570					
	VTR010	101 mm	4580					
	VTR115	115 mm	4580					
	VTR014	141 mm	10,673					
	VTR018	182 mm	24,780					

* 4 and 5:1 ratios not available with VTR006-VTR090.

UltraTRUE™	Helical True planetary inline gearbox, flange mount design with anodized aluminum housing employing RediMount™ system. Stainless steel housing, gear-path hobbled into stainless steel housing.							
	Inline	Frame Size Metric	Max T Peak (lb-in)		All Sizes	Gear Ratios Available	Efficiency	Backlash (arc-min)
			1 Stage	2 Stage				
	UT006	61 mm	890	1010	1 Stage	4, 5, 7, 10	95%	4
	UT075	75 mm	1580	1813				
	UT090	90 mm	1580	1813				
	UT010	101 mm	4548	5327				
	UT115	115 mm	4548	5327	2 Stage	16, 20, 25, 28, 35, 40, 50, 70, 100	90%	5
	UT014	141 mm	10,480	12,500				
	UT018	182 mm	24,010	29,200				
	UT022	220 mm	41,096	48,890				

UltraTRUE™	Helical True planetary right angle gearbox, flange mount design with anodized aluminum housing employing RediMount™ system. Stainless steel housing, gear-path hobbled into stainless steel housing.							
	Right Angle	Frame Size Metric	Max T Peak (lb-in)		All Sizes	Gear Ratios Available	Efficiency	Backlash (arc-min)
			1 Stage	2 Stage				
	UTR006	61 mm	456	975	1 Stage	1, 2, 3, 4, 5	98%	4
	UTR075	75 mm	1410	1740				
	UTR090	90 mm	1410	1740				
	UTR010	101 mm	2856	5085				
	UTR115	115 mm	2856	5085	2 Stage	8, 10, 12, 14, 15, 16, 20, 25, 28, 30, 35, 40, 50	93%	5
	UTR014	141 mm	6270	11,860				
	UTR018	182 mm	16,914	27,530				

Note 1: Torque capacity is maximum of frame size stage design, not all ratios have the same rated torque capacity.
 Note 2: Torque capacity is the maximum allowable momentary torque for emergency stopping or heavy shock loading.
 Note 3: Ratio 5P is designed using the compact PowerTrue face gearing technology.
 Note 4: Ratio 5T is designed using a True planetary gear stage for increased torque capacity.
 Note 5: For complete gearbox model nomenclature, refer to page 194.



AquaTRUE™ Hygienic IP69K Gearbox

The perfect gearbox to mate to the AKMH Series...

Micron's new AquaTRUE gearbox combines the high performance and torque capacity of Micron's True Planetary gearboxes with features specifically designed to meet the strict requirements of applications such as food and beverage handling, packaging and dispensing. The AquaTRUE's IP66/IP67 and IP69K protection is able to handle caustic cleaning chemicals as well as high pressure washdown. Until now, manufacturers have been unable to use gearboxes in many applications involving harsh environments because there was not a product available that met those needs. The AquaTRUE is engineered to be placed anywhere in the application's design, regardless of environmental factors. This eliminates the cost of additional components such as enclosers, shielding or mechanical transmissions.

The gearbox's 304 stainless steel housing eliminates the concern for rust or any type of corrosion. The AquaTRUE has a laser etched permanent product label and a smooth, round external housing that is designed without any external seams or corners for bacteria to collect. This makes the AquaTRUE very easy to clean and a perfect fit in any washdown environment.

- Frame Sizes: 60 mm, 80 mm, 120 mm, 160 mm
- Precision: 13 arc-min max
- Torque Capacity: up to 876 Nm
- Ratio Availability: 3:1 to 10:1 (1 and 2 stage)

Features and Benefits

- Round Housing
- No External Seams
- 300 Series Stainless Steel
- IP66/IP67 and IP69K Protection on both the input and output
- NSF/ANSI 169 Certification
- No corners or areas for bacteria to collect
- No areas of ingress
- Corrosion Resistance
- Can handle high pressure washdown

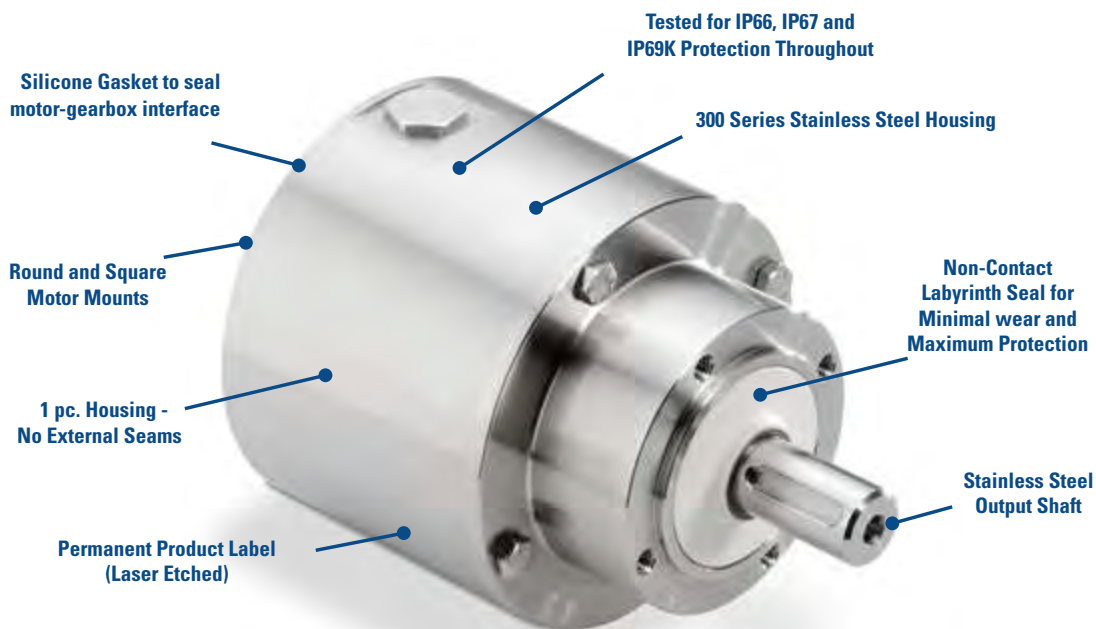

AquaTRUE™		True planetary gearbox, flange mount design with anodized aluminum housing employing RediMount™ system.						
Inline	Frame Size Metric	Max T Peak (lb-in)		All Sizes	Gear Ratios Available	Efficiency	Backlash (arc-min)	
		1 Stage	2 Stage					
AQT060	60 mm	483	483	1 Stage	3, 4, 5, 7, 8, 10	93%	13	
AQT080	80 mm	1460	1552					
AQT120	110.5 mm	2639	2639	2 Stage	15, 20, 25, 30, 40, 50, 70, 80, 100	88%	13	
AQT160	140 mm	7750	7750					



The AKMH can be ordered with the AquaTRUE gearbox mounted at our factory for a perfectly integrated hygienic gearmotor solution. If you need more power than the AKMH can provide, the addition of an AquaTRUE gearbox will add the power you need while maintaining a hygienic solution. The AKMH/AquaTRUE combination also maintains the IP69K rating. The hygienic stainless steel and food-grade materials make it a perfect fit for all your food and beverage applications.



Example P/N: "AKMH42E-CNKN-1K + AQT080-003-0-MMR-726"

Linear Actuation & Positioning Systems

LINEAR ACTUATORS

Kollmorgen offers a comprehensive range of linear actuator products including electric cylinders, rodless actuators, and precision tables to meet a wide range of application requirements. For actuator products not included in this catalog go to www.kollmorgen.com for information about other Kollmorgen linear positioning products.

	Model	Product Family	General Information
	Electric Cylinders ¹	EC1 EC2 EC3 EC4 EC5 N2	<ul style="list-style-type: none"> • Highest Force (Thrust) • Clean, Hydraulic Replacement • Compact Cross Section • Extends into Work Area
	Rodless Actuators (screw drive)	R2A R3 R4	<ul style="list-style-type: none"> • High Force (Thrust) • High Repeatability • Long Travel • Load Carrying Capability
	Rodless Actuators (belt drive)	R2A R3 R4	<ul style="list-style-type: none"> • Very High Speed • Quiet Operation • Long Travel • Load Carrying Capability
	Precision Tables	DS4 DS6	<ul style="list-style-type: none"> • High Accuracy & Repeatability • Low Maintenance, Long Life • High Moment Loads

Electric Cylinders (EC)

Primarily designed to apply a force through an extendable rod, electric cylinders are a clean and efficient replacement for hydraulic actuators and pneumatic cylinders, and an alternative to many types of linear transmissions. A wide variety of mounting and coupling alternatives significantly increases their problem solving potential.

Rodless Actuators

Long travel, quiet operation, and high moment loading differentiates rodless actuators from other mechanical transmissions.

Precision Tables

Positioning tables are used when accurate and repeatable motion is critical (1 part per 10,000 or better). These tables offer a wide variety of single and multi-axis configurations, open and closed frame tables, ball or lead screw driven, and overhung and constant support for Kollmorgen geometry configurations.

Model	Max Speed ³ In/s (mm/s)	Max Thrust ^{2,3} Lb (N)	Repeatability ^{4,5} In (mm)	Max Payload Lb (kg)	Max Travel In (mm)
Electric Cylinders ¹	52.5 (1330)	5620 (25,000)	to 0.0005 (0.013)	Note 1	59.1 (1500)
Rodless Actuators (screw drive)	39 (1000)	700 (3110)	to 0.0005 (0.013)	300 (136)	108 (2743)
Rodless Actuators (belt drive)	118 (3000)	300 (1330)	to 0.004 (0.10)	300 (136)	108 (2743)
Precision Tables	32.5 (825)	440 (1960)	3 microns (commer- cial grade) / 1.3 microns (precision grade)	794 (360)	79 (2000)

Notes:

1. Electric cylinders are designed primarily for thrust application where loads are supported externally.
2. Thrust ratings are based on mechanical limits rather than motor limits unless indicated otherwise.
3. Max speed and max thrust ratings are not necessarily available simultaneously
4. Repeatability is dependent on feedback resolution, load, friction, and drive gain settings.
5. Repeatability is unidirectional unless otherwise specified

Electric Cylinders N2 / EC Series

Electric cylinders are thrust-producing devices that are best suited for applications requiring high axial force with the moment and side loads already properly supported.

Kollmorgen has combined the broad product offering of the N2 and EC Series electric cylinders with the industry-leading AKM servo motors and AKD servo drives. The N2 and EC Series of electric cylinders offer a wide range of available thrusts in standard units from 600 lb (N2) to 5620 lb (EC5) across 5 electric cylinder frame sizes.

- Speeds up to 52 in/sec are available and integrated geared options provide the ability to increase thrust capacity for lower speed applications, leveraging the speed capacity of servo systems.
- Multiple servo motor options are available for the product line ranging from NEMA 23 size to NEMA 42 size servos. The combination with the AKM servo motor enables the use of various feedback devices including sine-encoder and the low-cost but high-performance Smart Feedback Device (SFD) when used with the AKD servo drive.
- Windings and voltage operation are not differentiated in MOTIONEERING®. All systems are offered at all voltages (240, 400, 480).
- The AKM servo motor comes mounted on the electric cylinder as specified by the electric cylinder part number. This eliminates time to match the motor to the electric cylinder and eliminates potential mechanical incompatibility.

EC Servo Linear Actuators

- Designed for performance
- Highest quality precision rolled ballscrews and lead screws – for quiet, long-life operation
- Brushless Servo motor and Stepper motor options available
- Sealed for IP54 protection. IP65 option available.
- Thrust up to 25000 N [5620 lb]
- Speed up to 1.3 m/s [52.5 in/s]
- Metric design (ISO 6431)
- Available in 5 power ranges – EC1, 2, 3, 4 & 5

N2 Servo Linear Actuators

- Smallest Package Size
- Time-Proven Design
- Improved Durability Over Previous Designs
- Thrust up to 2670 N [600 lb]
- Speed up to 0.76 m/s [30 in/sec]
- English dimensions (to NFPA standards)
- Brushless Servo with encoder, resolver or SFD feedback
- Stepper motors also available

Typical Construction (EC2 cut-away shown)

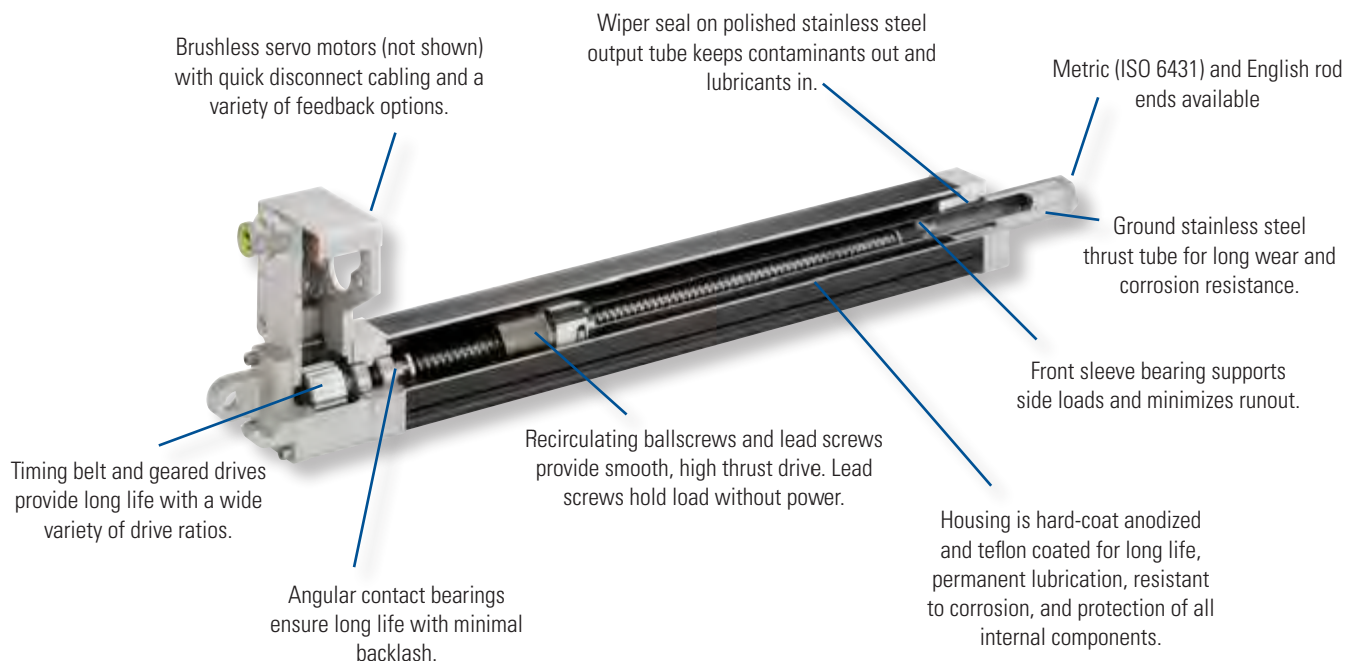

Kollmorgen offers electric cylinder drive mechanisms designed around either lead screws or ballscrews. Ballscrews, being the more efficient of the two, utilize ballnuts riding on recirculating ball bearings resulting in higher speeds, loads and cycle rates. However, the more efficient design of ballscrew technology lends it to being backdriven when power is removed if precautions are not taken (e.g., electric brakes or counter loading).

Lead screws are capable of holding the load in position when power is removed, but are less efficient in operation.

Kollmorgen's guide system prevents rotation of the ball / lead nut, thus eliminating any torque loading to machine linkage.

Electric Cylinders Are Preferred When:

- Positioning an externally guided and supported load.
- Moving a load that pivots.
- There is a high concentration of airborne contaminants (rodless actuators are inherently less well protected).
- Replacing a hydraulic or pneumatic cylinder with an electro-mechanical solution.

Specification Overview

Series	N2		EC1	EC2		EC3		EC4	EC5
Std. Maximum Stroke Length [in (mm)]	* 22.5 (571.5)		7.87 (200)	29.53 (750)		39.37 (1000)		59.06 (1500)	59.06 (1500)
Type of Screw	Lead	Ball	Ball	Lead	Ball	Lead	Ball	Ball	Ball
Lead	0.2 in, 0.5 in	0.2 in, 0.5 in	3 mm	4 mm	16, 5 mm	4 mm	16, 10, 5 mm	25, 10 mm	32, 10 mm
Nom. Lead Screw Diameter	0.625 in	0.625 in	10 mm	16 mm	16 mm	20 mm	20 mm	25 mm	32 mm
Backlash [in (mm)]	0.016 (0.40)	0.015 (0.38)	0.015 (0.38)	0.016 (0.40)	0.010 (0.25)	0.016 (0.40)	0.010 (0.25)	0.12 (0.30)	0.12 (0.30)
Dimension Std.	English NFPA Std.		Metric ISO6431 Std.						
Bore size			30 mm	50 mm		63 mm		80 mm	100 mm
Brushless Servo Motor	AKM23		AKM1x	AKM23		AKM23, AKM42, AKM52		AKM42, AKM52	AKM42, AKM52
Stepper Motor	T22		CTP12	T22, T31		T22, T31		T31, T32, T41	T31, T32, T41
Max. Thrust [lb (N)]	600 (2670)		150 (667)	810 (3600)		1620 (7200)		2700 (12,000)	5620 (25,000)
Max. Velocity [in/sec (m/s)]	12 (0.3)	30 (0.76)	13 (0.33)	9.2 (0.23)	50 (1.27)	8.0 (0.20)	50 (1.28)	52.5 (1.33)	52.5 (1.33)
Max. Rated Duty Cycle (load, speed dependent) [%]	50	100	100	50	100	50	100	100	100
Limit Switches	Optional								
Std. Operating Temperature Range [C (F)]	0 to 60 (32 to 140)		-30 to 70 (-22 to 158)						
Moisture/Contaminants	Humid, but Not Direct Contact		IP54 Std. IP65 Opt.						

*Note: Requires dual rod-end bearing option for length over 12"

Electric Cylinders N2 / EC Series

LINEAR ACTUATORS

ELECTRIC CYLINDERS N2/EC SERIES

Electric Cylinder EC Series General Outline Drawing

MF1 Front Flange Parallel

Flange dimensions in accordance with ISO 6431 for:	
Type	Bore Size
EC1	30 mm
EC2	50 mm
EC3	63 mm
EC4	80 mm
EC5	100 mm

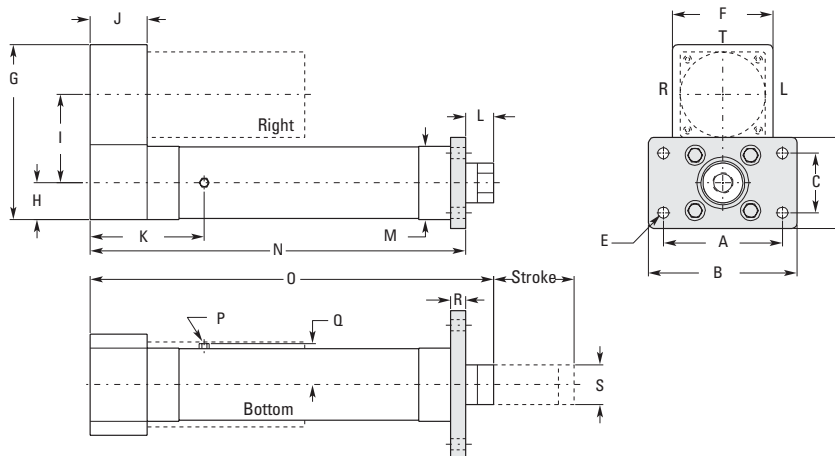

	A mm (in)	B mm (in)	C mm (in)	D mm (in)	E mm (in)	F mm (in)	G mm (in)	H mm (in)	I mm (in)	J mm (in)	K mm (in)
EC1	60.0 (2.36)	74.0 (2.91)	28.0 (1.10)	40.0 (1.57)	6.60 (0.26)	48.0 (1.89)	82.6 (3.25)	19.0 (0.75)	41.8 (1.65)	31.3 (1.23)	-
EC2	90.0 (3.54)	114.3 (4.50)	45.0 (1.77)	63.5 (2.50)	9.0 (0.35)	79.8 (3.14)	144.0 (5.7)	28.4 (1.12)	74.7 (2.94)	41.7 (1.64)	88.6 (3.49)
EC3	100.0 (3.94)	127.0 (5.00)	50.0 (1.97)	69.1 (2.72)	9.0 (0.35)	95.5 (3.76)	169.7 (6.7)	34.8 (1.37)	*87.6/89.7 (*3.45/3.53)	49.3 (1.94)	94.2 (3.71)
EC4 (-MF1E)	127.0 (5.00)	152.4 (6.00)	69.9 (2.75)	96.3 (3.79)	13.5 (0.53)	127.0 (5.00)	221.0 (8.7)	46.1 (1.81)	111.1 (4.37)	71.9 (2.83)	150.9 (5.94)
EC5	150.0 (5.91)	186.9 (7.36)	75.0 (2.95)	114.3 (4.50)	14.2 (0.56)	127.0 (5.00)	221.0 (8.7)	46.1 (1.81)	111.1 (4.37)	71.9 (2.83)	150.9 (5.94)

	L mm (in)	M mm (in)	N Cyl Length mm (in)	O Retract length mm (in)	P Breather port Hex		Q mm (in)	R mm (in)	S mm (in)
					type	mm (in)			
EC1	10.2 (0.40)	38.1 (1.50)	113.8 + S (4.48 + S)	124.0 + S (4.88 + S)	-	-	-	10.0 (0.39)	22.2 (0.88)
EC2	25.0 (0.98)	56.9 (2.24)	218.5 + S (8.6 + S)	243.4 + S (9.58 + S)	1/8 NPT	11.1 (0.44)	34.8 (1.37)	9.5 (0.37)	28.0 (1.10)
EC3	25.0 (0.98)	69.6 (2.74)	246.3 + S (9.7 + S)	271.1 + S (10.67 + S)	1/8 NPT	11.1 (0.44)	41.1 (1.62)	12.7 (0.50)	35.0 (1.38)
EC4 (-MF1E)	41.4 (1.63)	92.2 (3.63)	365.8 + S (14.4 + S)	406.9 + S (16.02 + S)	1/4 NPT	14.0 (0.55)	52.8 (2.08)	12.7 (0.50)	50.0 (1.97)
EC5	35.0 (1.38)	92.2 (3.63)	365.8 + S (14.4 + S)	406.9 + S (16.02 + S)	1/4 NPT	14.0 (0.55)	52.8 (2.08)	19.1 (0.75)	50.0 (1.97)

* AKM23 / AKM42 dimension

240 Vac Performance Data

Sys #	Electric Cylinder - AKM Servo motor	AKD Servo Drive	Cont. Thrust @ Speed (lb @ in/sec)	Peak Thrust @ Speed (lb @ in/sec)	Max Thrust (lb)	Max System Speed (in/sec)	**Max Stroke for Max Speed (mm)		
EC	1 EC1-AKM11B-■■■■-10-03B *	AKD-X00306	50	13.0	75	13.0	75	13.0	200
	2 EC1-AKM11B-■■■■-20-03B	AKD-X00306	100	6.0	125	6.0	125	6.0	200
	3 EC1-AKM11B-■■■■-40-03B	AKD-X00306	150	3.0	150	3.0	150	3.0	200
	4 EC1-AKM13C-■■■■-10-03B*	AKD-X00306	75	11.5	75	13.0	75	13.0	200
	5 EC1-AKM13C-■■■■-20-03B	AKD-X00306	125	5.9	125	6.0	126	6.0	200

Note 1: Refer to the Kollmorgen Electric Cylinder Catalog catalog, or contact customer support for matching cables.

Note 2: For complete AKD, EC, and N2 Series model nomenclature, refer to pages 176, 195 and 196, respectively.

* In-line type with 1-to-1 gear ratio (-10L) provide 10% additional thrust (not to exceed the max thrust).

** Based on critical speed of screw specification.

Electric Cylinder N2 Series General Outline Drawing

MF1 Front Rectangular Flange Mount Parallel

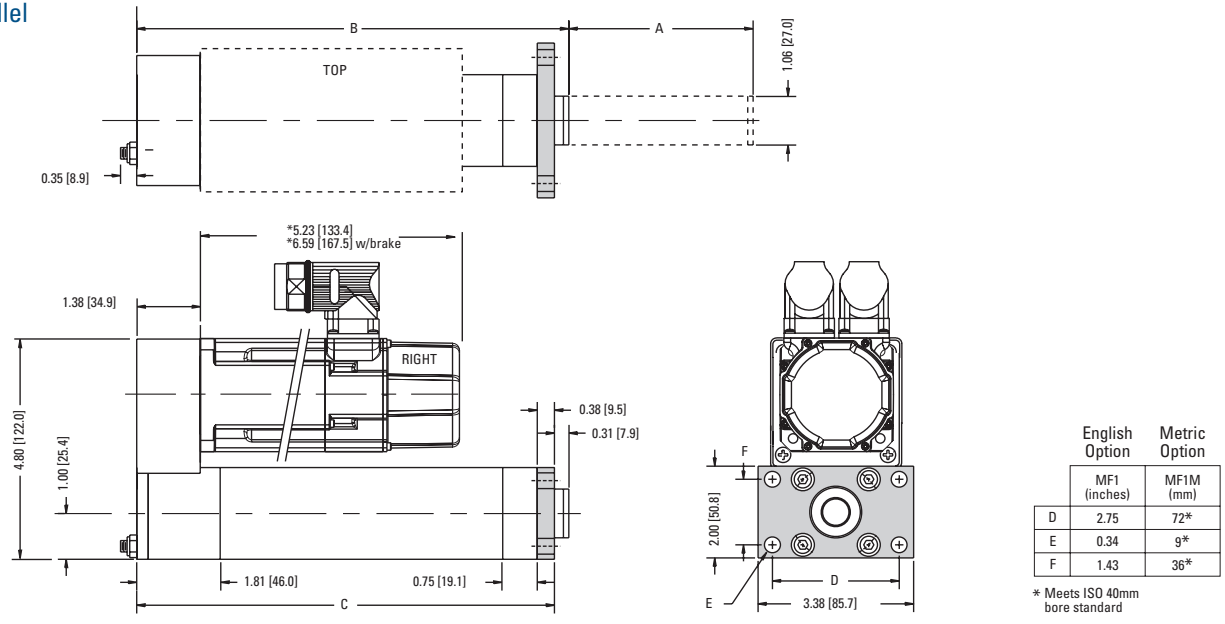

A	Standard Stroke Lengths Available						
inch	2.0	4.0	6.0	8.0	12.0	18.0	24.0
mm	50.8	101.6	152.4	203.2	304.8	457.2	609.6

B	Retract Length	C	Mounting length
inch	5.37 + S	inch	5.06 + S
mm	136.4 + S	mm	128.5 + S

* AKM23 with motor mounted connectors.

S = stroke

240 Vac Performance Data

Sys #	Electric Cylinder - AKM Servo motor	AKD Servo Drive	Cont. Thrust @ Speed (lb @ in/sec)	Peak Thrust @ Speed (lb @ in/sec)	Max Thrust (lb)	Max System Speed (in/sec)	**Max Stroke for Max Speed (mm)			
N2	1	N2-AKM23D-10-5B *	AKD-X00306	190	12.0	600	11.5	600	12.0	18.0
	2	N2-AKM23D-15-5B	AKD-X00306	287	8.0	600	8.0	600	8.0	18.0
	3	N2-AKM23D-20-5B	AKD-X00306	382	6.0	600	6.0	600	6.0	18.0
	4	N2-AKM23D-25-5B	AKD-X00306	370	4.8	600	4.8	600	4.8	18.0
	5	N2-AKM23D-120-5B	AKD-X00306	600	1.0	600	1.0	600	1.0	18.0
	6	N2-AKM23D-10-2B *	AKD-X00306	75	30.0	275	24.5	280	30.0	18.0
	7	N2-AKM23D-15-2B	AKD-X00306	115	20.0	412	16.4	421	20.0	18.0
	8	N2-AKM23D-20-2B	AKD-X00306	152	15.0	545	12.3	545	15.0	18.0
	9	N2-AKM23D-25-2B	AKD-X00306	146	12.0	534	9.8	545	12.0	18.0
	10	N2-AKM23D-120-2B	AKD-X00306	600	2.5	600	2.5	600	2.5	18.0
	11	N2-AKM23D-10-5A	AKD-X00306	86	12.0	305	9.8	312	12.0	18.0
	12	N2-AKM23D-15-5A	AKD-X00306	128	8.0	458	6.5	467	8.0	18.0
	13	N2-AKM23D-20-5A	AKD-X00306	169	6.0	600	4.9	600	6.0	18.0
	14	N2-AKM23D-25-5A	AKD-X00306	165	4.8	593	3.9	600	4.8	18.0
	15	N2-AKM23D-120-5A	AKD-X00306	600	1.0	600	1.0	600	1.0	18.0

Note 1: Refer to the Kollmorgen Electric Cylinder Catalog, or contact customer support for matching cables.
 Note 2: For complete AKD, EC, and N2 Series model nomenclature, refer to pages 176, 195 and 196, respectively.
 * In-line type with 1-to-1 gear ratio (-10L) provide 10% additional thrust (not to exceed the max thrust).
 ** Based on critical speed of screw specification.

Electric Cylinders N2 / EC Series

Low Speed Servo Performance

LINEAR ACTUATORS ELECTRIC CYLINDERS N2/EC SERIES

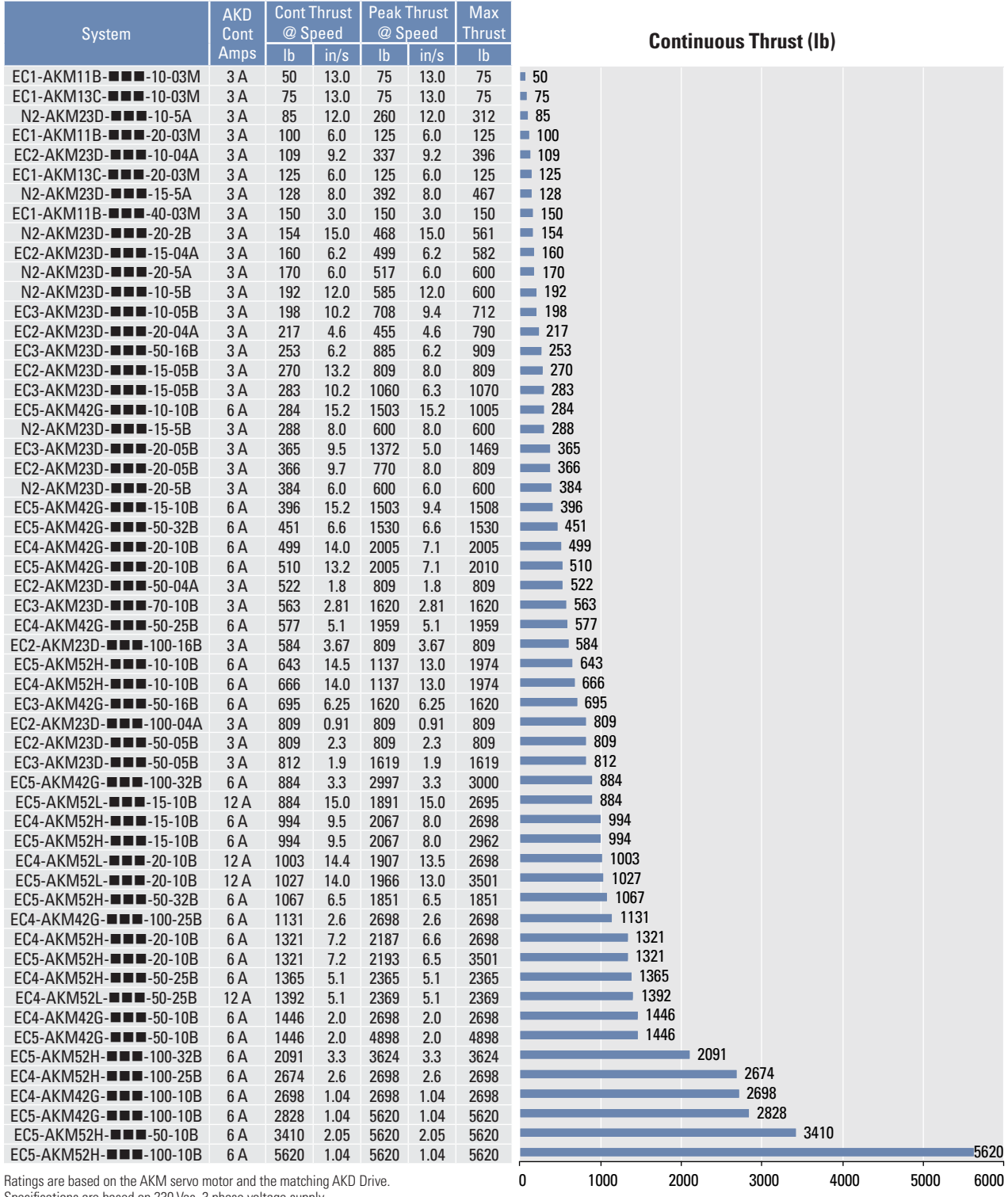

Ratings are based on the AKM servo motor and the matching AKD Drive. Specifications are based on 230 Vac, 3 phase voltage supply.

Plotted value is continuous thrust (lb), refer to chart for the associated rated speed value.

High Speed Servo Performance

System	AKD Cont Amps	Cont Thrust @ Speed		Peak Thrust @ Speed		Max Thrust
		lb	in/s	lb	in/s	
EC2-AKM23D-10-16B	3 A	59	50.0	221	30.0	222
EC3-AKM23D-10-16B	3 A	59	50.0	221	30.0	222
N2-AKM23D-10-2B	3 A	77	30.0	233	30.0	280
EC2-AKM23D-15-16B	3 A	84	42.0	293	23.0	327
EC3-AKM23D-15-16B	3 A	86	41.0	332	20.0	334
EC5-AKM42G-10-32B	6 A	87	52.5	313	45.0	313
EC4-AKM42G-10-25B	6 A	108	52.0	400	35.0	402
EC2-AKM23D-20-16B	3 A	115	31.0	223	26.0	445
N2-AKM23D-15-2B	3 A	115	20.0	350	20.0	420
EC3-AKM23D-20-16B	3 A	118	30.0	457	12.5	459
EC5-AKM42G-15-32B	6 A	122	52.5	470	30.0	470
EC3-AKM23D-15-10B	3 A	141	21.0	520	13.0	534
EC4-AKM42G-15-25B	6 A	149	47.0	595	24.0	603
EC3-AKM42G-10-16B	6 A	154	45.2	598	24.0	628
EC5-AKM42G-20-32B	6 A	156	45.0	626	22.5	628
EC2-AKM23D-10-05B	3 A	188	16.0	385	16.0	712
EC3-AKM23D-20-10B	3 A	190	18.0	686	10.0	735
EC4-AKM42G-20-25B	6 A	200	35.0	802	17.5	804
EC5-AKM52H-10-32B	6 A	207	46.0	351	42.0	617
EC3-AKM42G-15-16B	6 A	234	30.0	495	25.0	888
EC4-AKM52L-10-25B	12 A	244	52.5	422	52.5	719
EC4-AKM52H-10-25B	6 A	264	36.0	441	33.0	790
EC5-AKM52L-15-32B	12 A	265	52.0	584	52.0	842
EC4-AKM52L-15-25B	12 A	267	48.5	699	43.0	1078
EC3-AKM42G-10-10B	6 A	269	20.9	958	15.0	1010
EC4-AKM42G-10-10B	6 A	269	21.0	1002	14.2	1005
EC5-AKM52H-15-32B	6 A	312	30.0	626	26.0	925
EC5-AKM52L-20-32B	12 A	314	46.0	614	42.0	1094
EC3-AKM42G-15-10B	6 A	358	18.9	820	15.0	1420
EC4-AKM42G-15-10B	6 A	383	17.5	1501	9.5	1508
EC4-AKM52H-15-25B	6 A	396	24.0	827	20.0	1185
EC4-AKM52L-20-25B	12 A	406	35.5	785	33.0	1400
EC5-AKM52H-20-32B	6 A	413	23.0	684	21.0	1094
EC4-AKM52H-20-25B	6 A	529	18.0	879	16.0	1400
EC4-AKM52L-10-10B	12 A	610	21.0	1055	21.0	1797
EC4-AKM52L-15-10B	12 A	772	18.6	1825	17.0	2695

Continuous Thrust (lb)

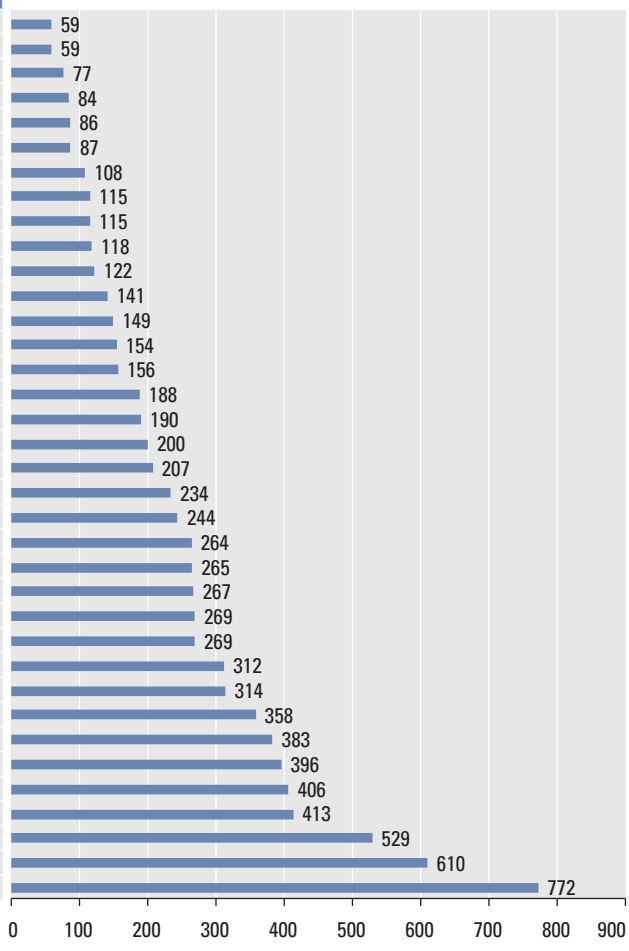

Ratings are based on the AKM servo motor and the matching AKD Drive. Specifications are based on 230 Vac, 3 phase voltage supply.

Plotted value is continuous thrust (lb), refer to chart for the associated rated speed value.

Rodless Actuators R-Series

L I N E A R A C T U A T O R S

R O D L E S S A C T U A T O R S R - S E R I E S



The name rodless actuator comes from this technology's close relationship to electric cylinders, sharing many of the same components. Rather than having a rod, rodless actuators incorporate a carriage supported by linear bearings. Where electric cylinders are designed to extend in and out of the work area delivering force or thrust, rodless actuators are designed to be load carrying mechanisms (up to 300 lb) incorporating ballscrews, leadscrews, or belt drive transmissions with optional integrated gearboxes.

Rodless actuators also share many of the fundamental design characteristics of precision positioning tables. Precision tables are designed to carry larger payloads and deliver superior repeatability and accuracy. Rodless actuators offer longer travels and higher speeds at a lower price. Screw driven rodless actuators are also thrust-producing devices that are best for axial force applications where the space is limited and a payload must also be supported or carried. As individual components, rodless actuators are not well suited for moment loading; however, they can be effectively combined into complete Cartesian systems for some multi-axis applications. For higher speed, lower thrust applications, rodless actuators can be repeatability-driven with a timing belt instead of a screw.

Kollmorgen has combined the broad product offering of the R-Series rodless actuators with the industry-leading AKM servo motors and AKD servo drives. The R-Series of rodless actuators offer a wide range of available thrusts in standard units with three basic frame sizes (R2A, R3, R4).

Rodless actuators offer longer travels (up to 108") and higher speeds (belt drives up to a maximum speed of 120 in/sec). Integrated geared options provide the ability to increase thrust capacity for lower speed applications leveraging the speed capacity of servo systems.

Multiple servo motor options are available for the product line, ranging from NEMA 23 size to NEMA 42 size servos. The combination with the AKM servo motor enables the use of various feedback devices including sine-encoder and the low-cost but high-performance Smart Feedback Device (SFD) when used with the AKD servo drive.

The AKM servo motor comes mounted on the rodless actuators as specified by the rodless actuator part number. This eliminates time to match the motor to the electric cylinder and eliminates potential mechanical incompatibility.

The operation of rodless actuators is similar to the electric cylinders described earlier. However, instead of an extending rod, a rodless unit features a moving carriage supported by linear bearings within an extruded aluminum chassis. This gives the rodless actuator the ability to guide and support a load, as well as position it.

Kollmorgen rodless actuators are designed for outstanding overall performance, value, flexibility and reliability in industrial applications.

Rodless Actuators Are Preferred When:

- A low cost system is needed to both position and guide a load
- It is desired to eliminate external guides and ways
- The shortest overall work envelope (extended length equals retracted length) is required
- Multiple units will be combined into Cartesian systems
- There is a need for a compact cross-sectional linear positioning system

Typical Construction

(R4 belt-driven cutaway shown)

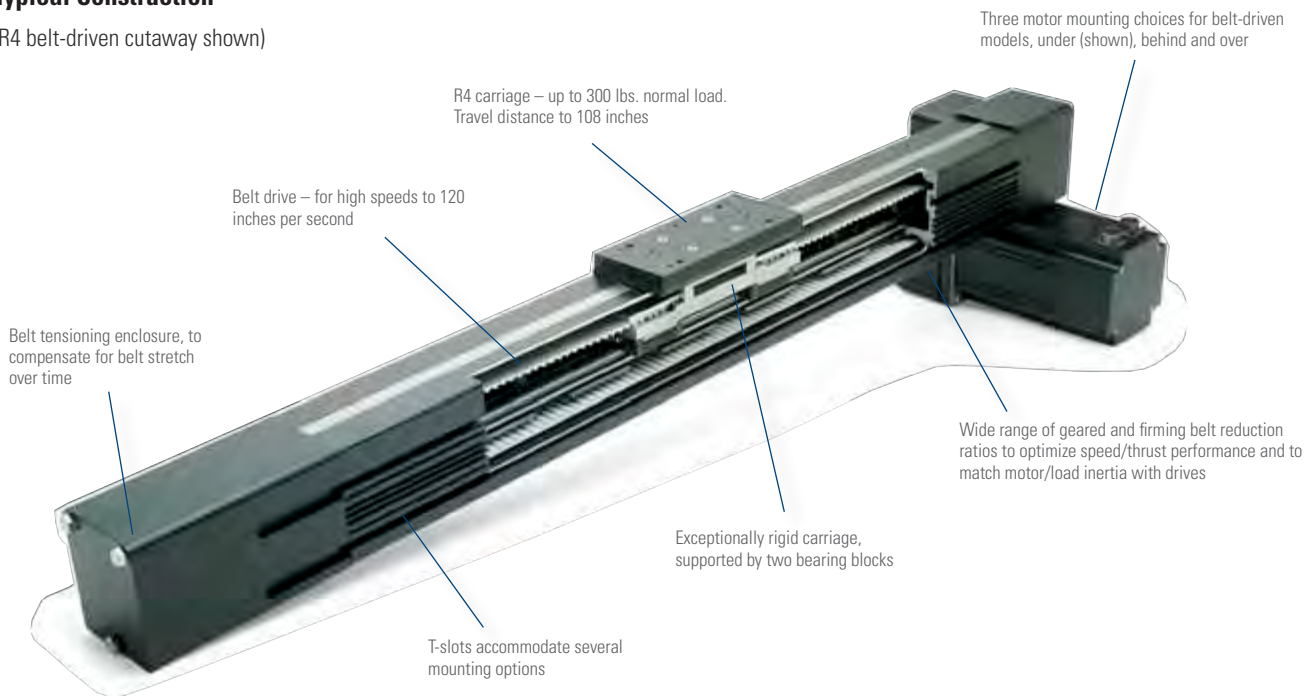

Rodless Actuators R-Series

LINEAR ACTUATORS
 RODLESS ACTUATORS R-SERIES

R3 Screw Drive

R3 screw drive with AKM42, parallel below motor orientation and flange mounting shown.

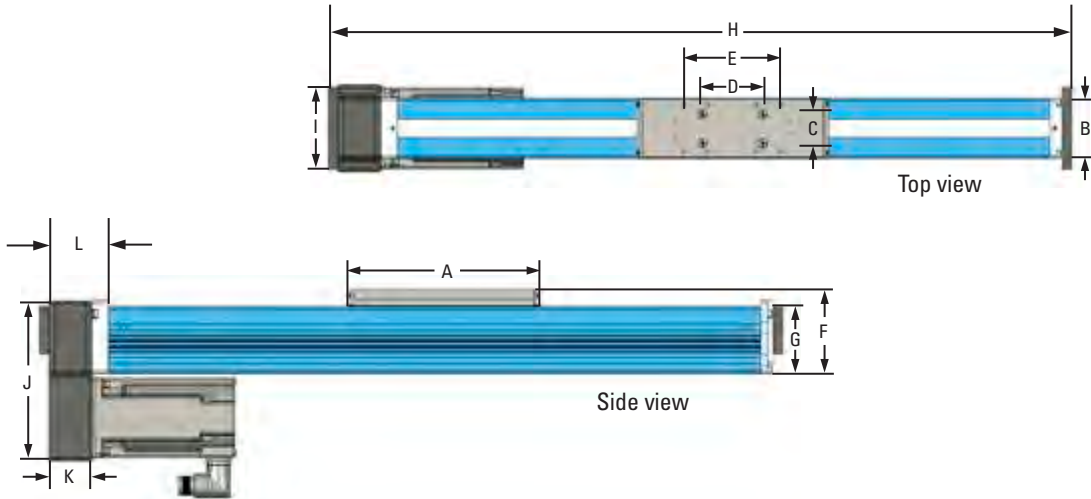

R3 Belt Drive

R3 belt drive with AKM42, behind left motor orientation and angle bracket feet shown.

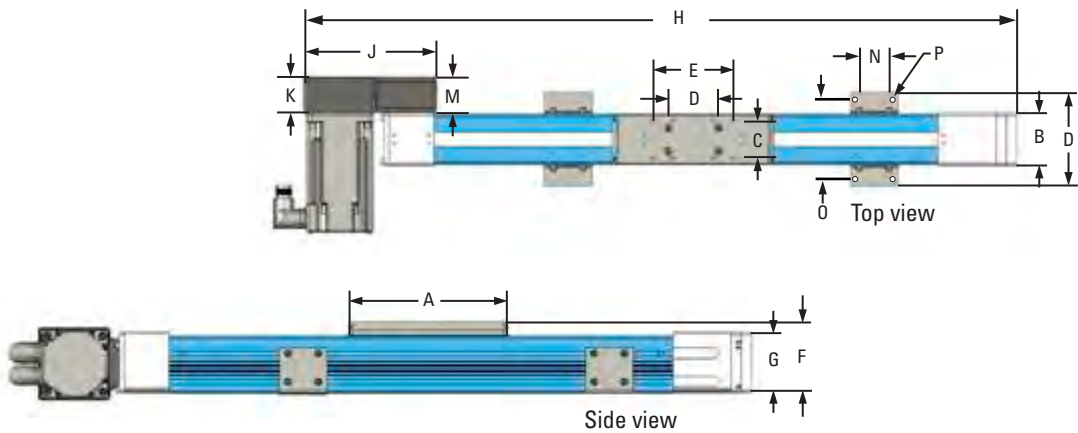

Carriage Mounting Features

	Metric Version (mm)	English Version (inch)
RA2	8 x M5 x 0.8 x 8.0 deep	8 x 10-32 UNF x 0.31 deep
R3	8 x M5 x 0.8 x 9.6 deep	8 x 10-32 UNF x 0.38 deep
R4	4 x M6 x 1 x 12 deep	4 x 1/4-20 x 0.50 deep

Dimension Data

	A	B	C	D	E
	mm (in)	mm (in)	mm (in)	mm (in)	mm (in)
RA2	210 (8.25)	50.8 (2.00)	31.8 (1.25)	50.8 (2.00)	101.6 (4.00)
R3	197 (7.76)	63.5 (2.50)	47.6 (1.88)	50.8 (2.00)	101.6 (4.00)
R4	197 (7.76)	92.2 (3.63)	63.5 (2.50)	NA	127.0 (5.00)

	F	G	H (Screw)	H (Belt)
	mm (in)	mm (in)	mm (in)	mm (in)
RA2	71.9 (2.83)	50.8 (2.00)	"S" + 345.3 (13.59)	"S" + 378.3 (14.89)
R3	88.8 (3.50)	71.5 (2.82)	"S" + 326.4 (12.85)	"S" + 522.0 (20.55)
R4	71.9 (2.83)	108.0 (4.25)	"S" + 411.8 (16.21)	"S" + 578.6 (22.78)

S = stroke

	I	J	K	L
	mm (in)	mm (in)	mm (in)	mm (in)
RA2	72.1 (2.84)	123.2 (4.85)	43.0 (1.69)	90.7 (3.57)
R3	91.4 (3.60)	168.9 (6.65)	45.5 (1.79)	88.1 (3.47)
R4	127.0 (5.00)	220.7 (8.69)	71.9 (2.83)	147.8 (5.82)

	M	N	O	P
	mm (in)	mm (in)	mm (in)	mm (in)
RA2	50.1 (1.97)	NA	88.8 (3.50)	8.7 (0.34) thru
R3	45.5 (1.79)	47.6 (1.88)	101.6 (4.00)	5.5 (0.22) thru
R4	71.9 (2.83)	63.5 (2.50)	127.0 (5.00)	7.0 (0.28) thru

Rodless Actuators R-Series

LINEAR ACTUATORS
 RODLESS ACTUATORS R-SERIES

General Specifications

Series	R2A			R3			R4	
Std max stroke length (in)	72			108			108	
Cross section (in)	2 x 2			2.5 x 2.8			3.6 x 4.25	
Guide type	Roller Guides			Profile Rail			Profile Rail	
Drive type	Ballscrew	Lead Screw	Belt	Ballscrew	Lead Screw	Belt	Ballscrew	Belt
Screw leads (in/rev)	0.5, 0.2	0.2, 0.125	n/a	0.5, 0.2	0.2, 0.125	n/a	1, 0.25	n/a
Nominal screw diameter (in)	0.625	0.625	n/a	0.625	0.625	n/a	1	n/a
Brushless servo motor	AKM23, NEMA 23			AKM23, NEMA 23, AKM42, NEMA 34			n/a	
Max thrust (lb)	100		72	300		200	700	300
Max velocity (in/sec)	30		80	30		120	40	120
Max carriage load								
Normal (lb)	50			100			300	
Roll moment (lb-in)	50			300			600	
Pitch moment (lb-in)	100			500			1000	
Repeatability (in)	+/-0.001		+/-0.010	+/-0.001		+/-0.010	+/-0.001	+/-0.010
Max duty cycle (speed, load dependent)	100%	60%	100%	100%	60%	100%	100%	100%
Limit sensors	Optional							
Std operating temperature range	-20 deg F to 140 deg F (-28 deg C to 60 deg C)							
Moisture/contamination	IP 44 rated: Splash-proof, protected against ingress of solid particles greater than 0.040 [1 mm] diameter.*							

Belt Based Systems

Belt Based System	AKD Cont. Amps	Cont. Thrust @ speed		Peak Thrust @ speed		Max Thrust
		lb	in/s	lb	in/s	
R3-AKM23D-xxx-15T	3 A	4.4	118	29	118	29
R3-AKM23D-xxx-20T	3 A	7.6	118	41	118	41
R2A-AKM23D-xxx-15T	3 A	13	80	64	80	64
R2A-AKM23D-xxx-20T	3 A	19	80	78	80	87
R3-AKM23D-xxx-50T	3 A	21	71	76	71	92
R4-AKM42G-xxx-20T	6 A	25	118	100	118	100
R3-AKM23D-xxx-70T	3 A	32	51	108	51	131
R3-AKM42G-xxx-20T	6 A	32	118	117	118	126
R4-AKM42G-xxx-30T	6 A	39	100	139	100	153
R4-AKM42G-xxx-50T	6 A	57	59	200	59	219
R3-AKM42G-xxx-50T	6 A	66	72	138	72	200
R4-AKM52H-xxx-20T	6 A	66	118	200	90	202
R3-AKM42G-xxx-70T	6 A	94	51	197	51	200
R4-AKM52H-xxx-30T	6 A	96	92	300	60	300
R4-AKM42G-xxx-100T	6 A	118	30	300	30	300
R4-AKM52H-xxx-50T	6 A	137	54	300	44	300
R4-AKM52H-xxx-100T	6 A	285	27	300	27	300

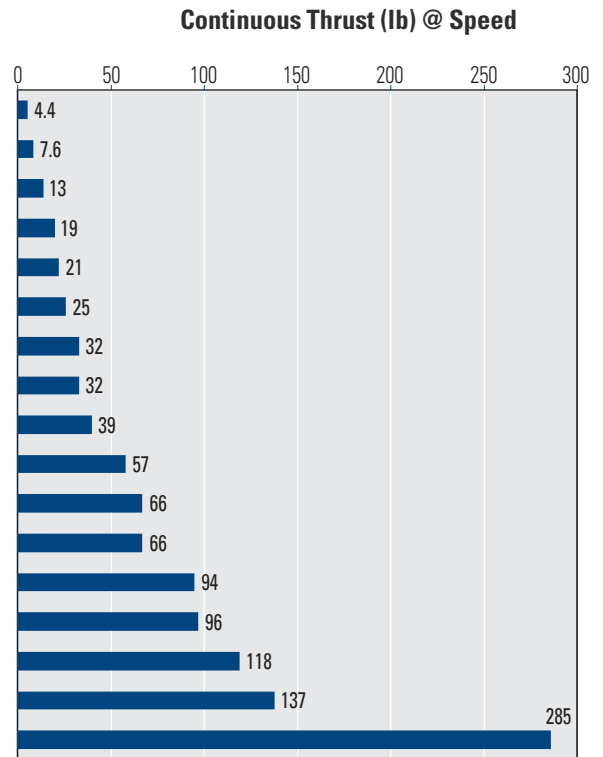

Screw Based Systems

Screw Based System	AKD Cont. Amps	Cont. Thrust @ speed		Peak Thrust @ speed		Max Thrust
		lb	in/s	lb	in/s	
R2A-AKM23D-xxx-102B-yy-P	3 A	70	30	100	30	100
R3-AKM23D-xxx-102B-yy-P	3 A	71	30	269	25	275
R2A-AKM23D-xxx-105A-yy-P	3 A	79	12	100	12	100
R3-AKM23D-xxx-105A-yy-P	3 A	80	12	255	12	300
R2A-AKM23D-xxx-152B-yy-P	3 A	100	20	100	20	100
R2A-AKM23D-xxx-155A-yy-P	3 A	100	8.0	100	8	100
R4-AKM42G-xxx-101B-yy-P	6 A	105	40	356	40	390
R3-AKM23D-xxx-152B-yy-P	3 A	110	20	300	20	300
R3-AKM23D-xxx-155A-yy-P	3 A	122	8.0	300	8.0	300
R3-AKM23D-xxx-108A-yy-P	3 A	131	7.5	300	7.5	300
R3-AKM23D-xxx-202B-yy-P	3 A	148	15	300	15	300
R4-AKM42G-xxx-151B-yy-P	6 A	161	27	540	27	588
R3-AKM23D-xxx-205A-yy-P	3 A	165	6.0	300	6.0	300
R3-AKM23D-xxx-105B-yy-P	3 A	186	12	300	12	300
R3-AKM23D-xxx-158A-yy-P	3 A	199	5.0	300	5.0	300
R3-AKM42G-xxx-102B-yy-P	6 A	201	30	300	30	300
R4-AKM42G-xxx-201B-yy-P	6 A	217	20	700	20	700
R3-AKM42G-xxx-105A-yy-P	6 A	249	12	300	12	300
R4-AKM52H-xxx-101B-yy-P	6 A	263	37	263	37	700
R3-AKM23D-xxx-208A-yy-P	3 A	267	3.8	300	3.8	300
R3-AKM23D-xxx-155B-yy-P	3 A	283	8.0	300	8.0	300
R3-AKM23D-xxx-505A-yy-P	3 A	300	2.4	300	2.4	300
R3-AKM42G-xxx-152B-yy-P	6 A	300	20	300	20	300
R3-AKM42G-xxx-155A-yy-P	6 A	300	8.0	300	8.0	300
R4-AKM52H-xxx-151B-yy-P	6 A	307	25	307	25	700
R4-AKM42G-xxx-104B-yy-P	6 A	440	10	700	10	700
R4-AKM42G-xxx-501B-yy-P	6 A	468	7.8	700	7.8	700
R4-AKM52H-xxx-201B-yy-P	6 A	517	18	600	18	700
R4-AKM42G-xxx-154B-yy-P	6 A	660	6.7	700	6.7	700
R4-AKM52H-xxx-104B-yy-P	6 A	700	9.4	700	9.4	700

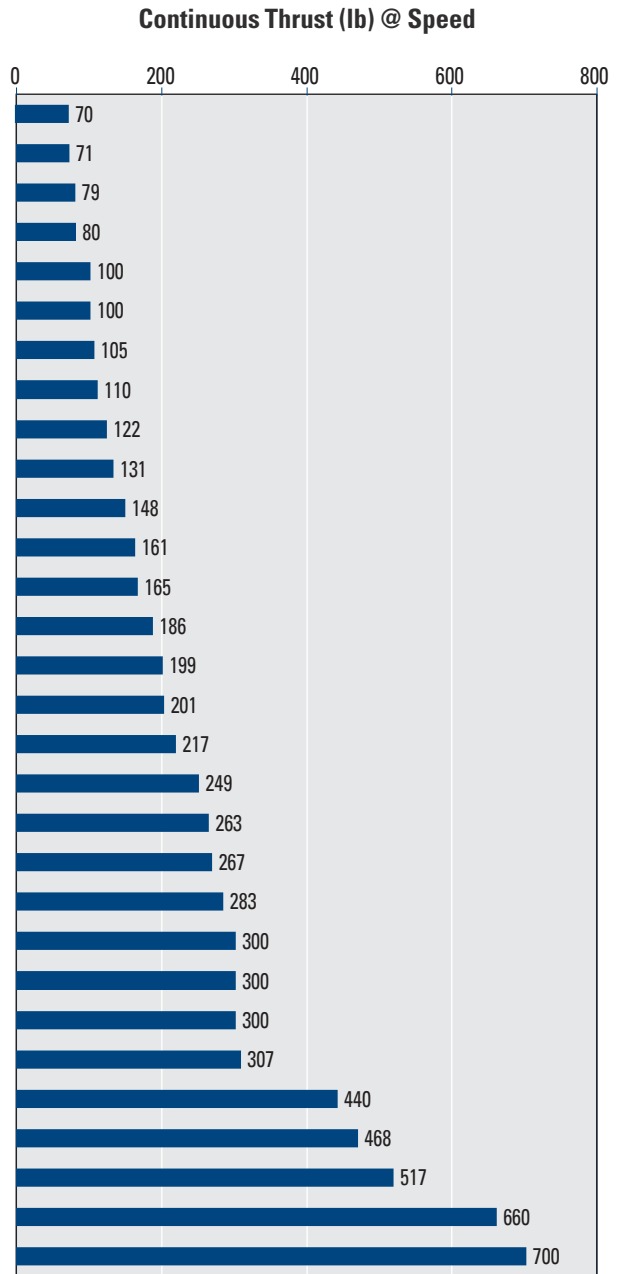

Precision Tables DS4 / DS6 Series

Precision positioning tables are best suited for applications where the accuracy and repeatability requirements are more important than axial thrust of the drive train. Precision positioning tables can also be used in less precise applications where adequate moment load support is necessary, and are ideal building blocks for complete multi-axis positioning systems.

The DS4 and DS6 are Kollmorgen's most versatile and modular line of positioning tables.

Combined with the AKD® Servo Drive and AKM® Servo Motors, DS4 and DS6 Systems Offer

- An optimized electromechanical solution suitable for demanding high precision positioning
- Performance and versatility in a compact package
- Outstanding industrial durability
- Tremendous configuration flexibility
- Industry-leading price vs. performance value

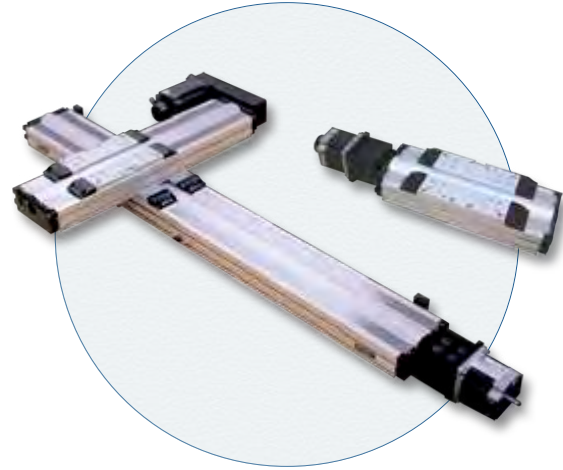

DS Series Design Features

Following are several features that make the DS Series the positioning table of choice for the most demanding applications:

- Travel lengths from 50 mm to 2 m cover a wide range of applications.
- Precision ballscrew drive, with 5 mm, 10 mm and 25 mm leads, offers high speed and efficiency, excellent repeatability and accuracy, and mechanical advantage.
- Proven magnetic stainless steel seal strip technology effectively seals the internal components of the DS Series, protecting the ballscrew and ways from contaminants. This feature also contains ballscrew and way lubrication within the DS Series.
- Easily configurable modular design and option set, including a variety of motor mounting orientations, motor sizes and type, ballscrew leads, coupling types and sizes, encoder feedback options, limit/home sensor types, and shaft brakes allow the DS Series to be customized to meet your specific requirements.

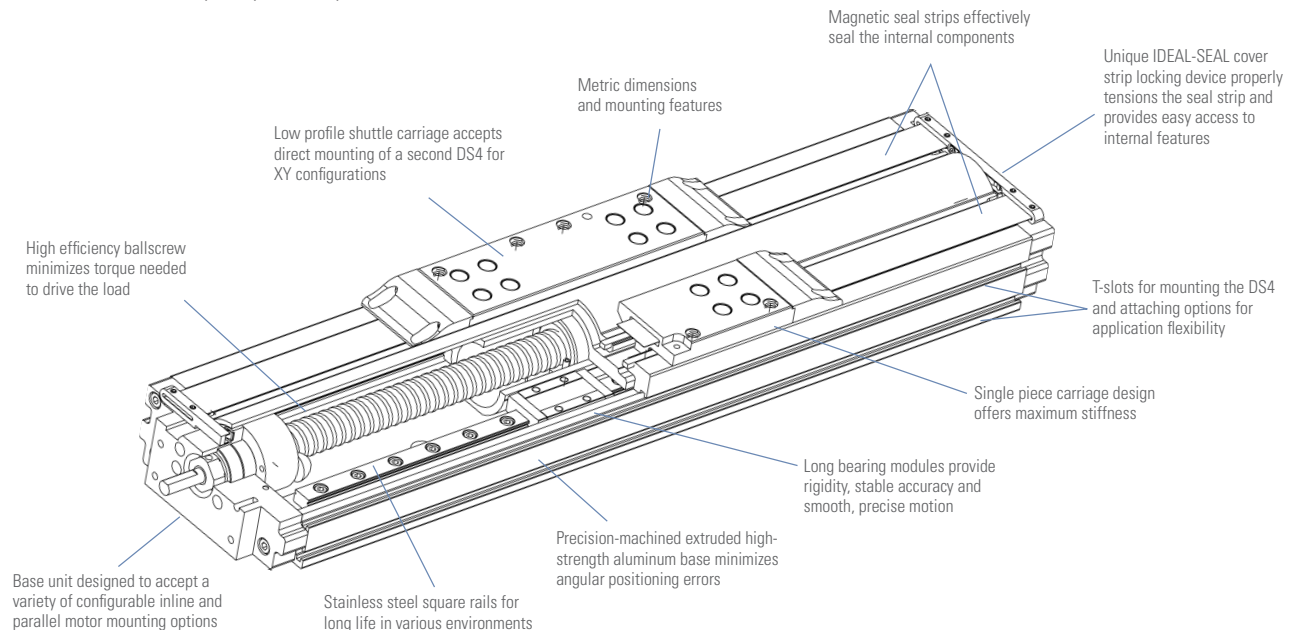

LINEAR ACTUATORS
 PRECISION TABLES DS4/DS6 SERIES

DS Series precision tables can be ordered in a variety of multi-axis configurations including XY, XZ, and XYZ or cartesian arrangements. Consult Kollmorgen applications engineering for standard and custom configurations.

A second option is to order standard multi-axis brackets and assemble the axes yourself.

Unique IDEAL-SEAL Magnetic Cover Strip Locking Device

- Entire length of lead screw and linear bearing system are protected, providing both operator safety and protection from contaminants.
- Seal strips are always properly tensioned, drastically decreasing wear that requires regular field repair.
- Allows easy access to interior of DS4 for mounting and maintenance.
- No small hardware or springs to lose, and no exposure to the sharp ends of the strips, which are problems for similar seal end-cap designs.



All DS4 and DS6 tables will bolt directly together in a standard XY without modification.

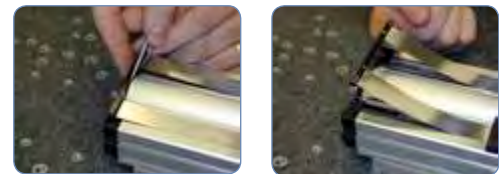

Configurable Options

DS Series	
Servo motor options	AKM23D, AKM42G
Grades	Precision* (up to 600 mm), commercial
Motor orientations	In-line, parallel right/left/under
Couplings options** (inline configurations)	Bellows
Transmission ratio (parallel configurations)	1:1
Limit sensors	PNP (sinking) inductive proximity sensors, 5-30 Vdc
Home sensor	PNP (sinking) inductive proximity sensors, 5-30 Vdc
Shaft brake	Electromagnetic power of holding brake, 24 Vdc
Linear encoder options	1.0, 0.5 and 0.1 motion resolution, modular incremental type

* Additional lead time applies to precision grade. Contact customer support for details.

** Additional couplings available. Contact customer support for details.

Accessories

DS Series	
Toe clamps	Provide convenient external mounting to a base plate or to riser blocks
Narrow riser blocks	Raise unit for clearance of larger motor options, utilizing internal base mounting features on the side
Wide riser blocks	Allow rising of the unit, independent of base mounting features
Brackets and mounting plates	Facilitate multi-axis configurations
Cable sets	For connection to AKD and other drives



Limit Sensor



Linear Encoder



Toe Clamp

Precision Tables DS4 / DS6 Series

LINEAR ACTUATORS

PRECISION TABLES DS4/DS6 SERIES

DS4 General Specifications

Travel (mm)	50	100	150	200	250	300	350	400	450	500	550	600	
Overall height, less motor (mm)	47												
Width (mm)	95												
System length, Inline less motor (mm)	317	367	417	467	517	567	617	667	717	767	817	867	
System length, parallel motor mounts (mm)	300	350	400	450	500	550	600	650	700	750	800	850	
Positional accuracy (microns)													
Commercial grade	12	12	14	20	22	24	26	26	28	34	36	40	
Precision grade	8	8	10	12	12	14	14	16	19	21	23	25	
Straightness & flatness (microns)	6	6	9	12	12	14	18	21	23	23	25	25	
Bi-directional repeatability, open loop													
Commercial grade (microns)	+/- 3												
Precision grade (microns)	+/- 1.3												
Load capacity, normal (kg) (max)	170												
Axial load capacity (kg)	90												
Acceleration (max) (m/sec ²)	20												
Moving mass (kg)	0.75												
Total mass (kg)	2.7	3	3.3	3.6	3.9	4.1	4.4	4.7	5	5.3	5.6	5.9	
Ballscrew diameter (mm)	16												
Duty cycle (%)	100												
Ballscrew efficiency	90												
Max. breakaway torque (oz-in)	18												
Max. running torque (oz-in)	16												
Ballscrew lead available (mm)	5, 10												
Input inertia (10 ⁻⁵ kg-m ²)	1.17	1.24	1.67	1.93	2.18	2.43	2.68	2.93	3.19	3.44	3.69	3.94	
Max. ballscrew speed (rev/sec)	80						60		55		50		

DS6 General Specifications

Travel (mm)	100	200	300	400	500	600	700	800	900	1000	1250	1500	1750	2000										
Overall height (mm)	70																							
Width (mm)	150																							
System length, inline less motor (mm)	465	565	665	765	865	965	1065	1165	1265	1365	1615	1865	2115	2365										
System length, parallel motor mounts (mm)	470	570	670	770	870	970	1070	1170	1270	1370	1620	1870	2120	2370										
Positional accuracy (microns)																								
Commercial grade	14	22	28	39	45	48	92	94	103	105	118	134	154	159										
Precision grade	12	14	15	20	25	50	-	-	-	-	-	-	-	-										
Straightness & flatness (microns)	10	14	17	23	30	33	40	46	50	55	76	95	115	135										
Bi-directional repeatability, open loop																								
Commercial grade (microns)	+/- 3							+/-5																
Precision grade (microns)	+/- 1.3							N/A																
Load capacity, normal (kg) (max)	630																							
Axial load capacity (kg)																								
Commercial grade	90							200																
Precision grade	90							N/A																
Acceleration (max) (m/sec ²)	20																							
Moving mass (kg)	2.8																							
Total mass (kg)	8.9	10.2	11.5	12.8	14.0	15.4	19.4	20.9	22.4	23.9	27.8	31.6	35.4	40.1										
Ballscrew diameter (mm)	16							25																
Duty cycle (%)	100																							
Ballscrew efficiency	90							80																
Max. breakaway torque (oz-in)	18							55																
Max. running torque (oz-in)	16							48																
Ballscrew lead available (mm)	5, 10							5, 10, 25																
Input inertia (10 ⁻⁵ kg-m ²)	3.8	4.4	5	5.5	6.1	6.7	37	40.4	43.9	47.3	56	64.5	73.2	81.9										
Max. ballscrew speed (rev/sec)	80			60			50		60		50		40		35		24		16		13		11	

*All performance specifications are based upon proper mounting procedures, with the DS table fully supported on a flat surface (flat within 0.008 mm/300 mm). Positional accuracy and repeatability specifications are for inline motor mount models only. Contact customer support for specifications of parallel mount configurations. Above specifications are measured 37.5 mm directly above the center of the carriage. Specifications are based upon operation at 20° C.

120 Vac Performance Data

	Sys #	Precision Table - AKM Servo Motor	AKD Servo Drive	Stroke Length Type	Cont. Thrust @ Speed (lb @ in/sec)		Peak Thrust @ Speed (lb @ in/sec)		Max Thrust (lb)	Max System Speed (in/sec)	Max Stroke for Max Speed (mm)
DS4	1	DS4-XXX-10G-AKM23D-■■■■	AKD-X00306	≤ 600 mm	104	17.6	210	10.8	210	17.6	600
	2	DS4-XXX- 5G-AKM23D-■■■■	AKD-X00306	≤ 600 mm	195	8.8	210	8.4	210	8.8	600
DS6	3	DS6-XXX-25G-AKM23D-■■■■	AKD-X00306	≤ 600 mm	37	44.0	138	8.2	138	44.0	600
	4	DS6-XXX-10G-AKM23D-■■■■	AKD-X00306	≤ 600 mm	104	17.6	210	12.4	210	17.6	600
	5	DS6-XXX- 5G-AKM23D-■■■■	AKD-X00306	≤ 600 mm	195	8.8	210	8.6	210	8.8	600
DS6	6	DS6-XXX-25G-AKM23D-■■■■	AKD-X00306	≥ 700 mm	41	44.0	138	8.2	154	44.0	800
	7	DS6-XXX-10G-AKM23D-■■■■	AKD-X00306	≥ 700 mm	91	17.6	331	3.1	376	17.6	800
	8	DS6-XXX- 5G-AKM23D-■■■■	AKD-X00306	≥ 700 mm	143	8.8	440	5.0	440	8.8	800

240 Vac Performance Data

	Sys #	Precision Table - AKM Servo Motor	AKD Servo Drive	Stroke Length Type	Cont. Thrust @ Speed (lb @ in/sec)		Peak Thrust @ Speed (lb @ in/sec)		Max Thrust (lb)	Max System Speed (in/sec)	Max Stroke for Max Speed (mm)
DS4	1	DS4-XXX-10G-AKM23D-■■■■	AKD-X00306	≤ 600 mm	98	31.5	210	31.5	210	31.5	300
	2	DS4-XXX- 5G-AKM23D-■■■■	AKD-X00306	≤ 600 mm	184	15.7	210	15.7	210	15.7	300
DS6	3	DS6-XXX-10G-AKM23D-■■■■	AKD-X00306	≤ 600 mm	98	31.5	210	31.5	210	31.5	300
	4	DS6-XXX- 5G-AKM23D-■■■■	AKD-X00306	≤ 600 mm	184	15.7	210	15.7	210	15.7	300
	5	DS6-XXX-25G-AKM23D-■■■■	AKD-X00306	≥ 700 mm	40	59	154	47	154	59	700
	6	DS6-XXX-10G-AKM23D-■■■■	AKD-X00306	≥ 700 mm	88	23.6	374	18	374	23.6	700
	7	DS6-XXX- 5G-AKM23D-■■■■	AKD-X00306	≥ 700 mm	138	11.8	440	11.8	440	11.8	700
	8	DS6-XXX-10G-AKM42G-■■■■	AKD-X00306	≤ 600 mm	210	28.4	210	28.4	210	28.4	300
	9	DS6-XXX- 5G-AKM42G-■■■■	AKD-X00306	≤ 600 mm	210	14.5	210	14.5	210	14.5	300
	10	DS6-XXX-25G-AKM42G-■■■■	AKD-X00306	≥ 700 mm	114	59	438	35.8	438	59	700
	11	DS6-XXX-10G-AKM42G-■■■■	AKD-X00306	≥ 700 mm	272	23.6	440	23.6	440	23.6	700
	12	DS6-XXX- 5G-AKM42G-■■■■	AKD-X00306	≥ 700 mm	440	11.8	440	11.8	440	11.8	700

Note 1: Performance based on in-line motor configuration.
 Note 2: Contact customer support for matching cables.
 Note 3: For complete AKD and DS4 / DS6 Series model nomenclature, refer to pages 176 and 198 respectively.

PMDC Permanent Magnet DC Motors

Why have design engineers depended on Kollmorgen permanent magnet DC motors for nearly 50 years? Value and Performance. Rugged, quality construction, backed by a 2 year warranty.

Plus, when you need something special, you know we've built thousands of custom-designed motors. Many more than we could ever show with these pages.

And if we don't have just what you need, we'll design you a new one, even for a modest volume requirement.

Standard PMDC Motor Features

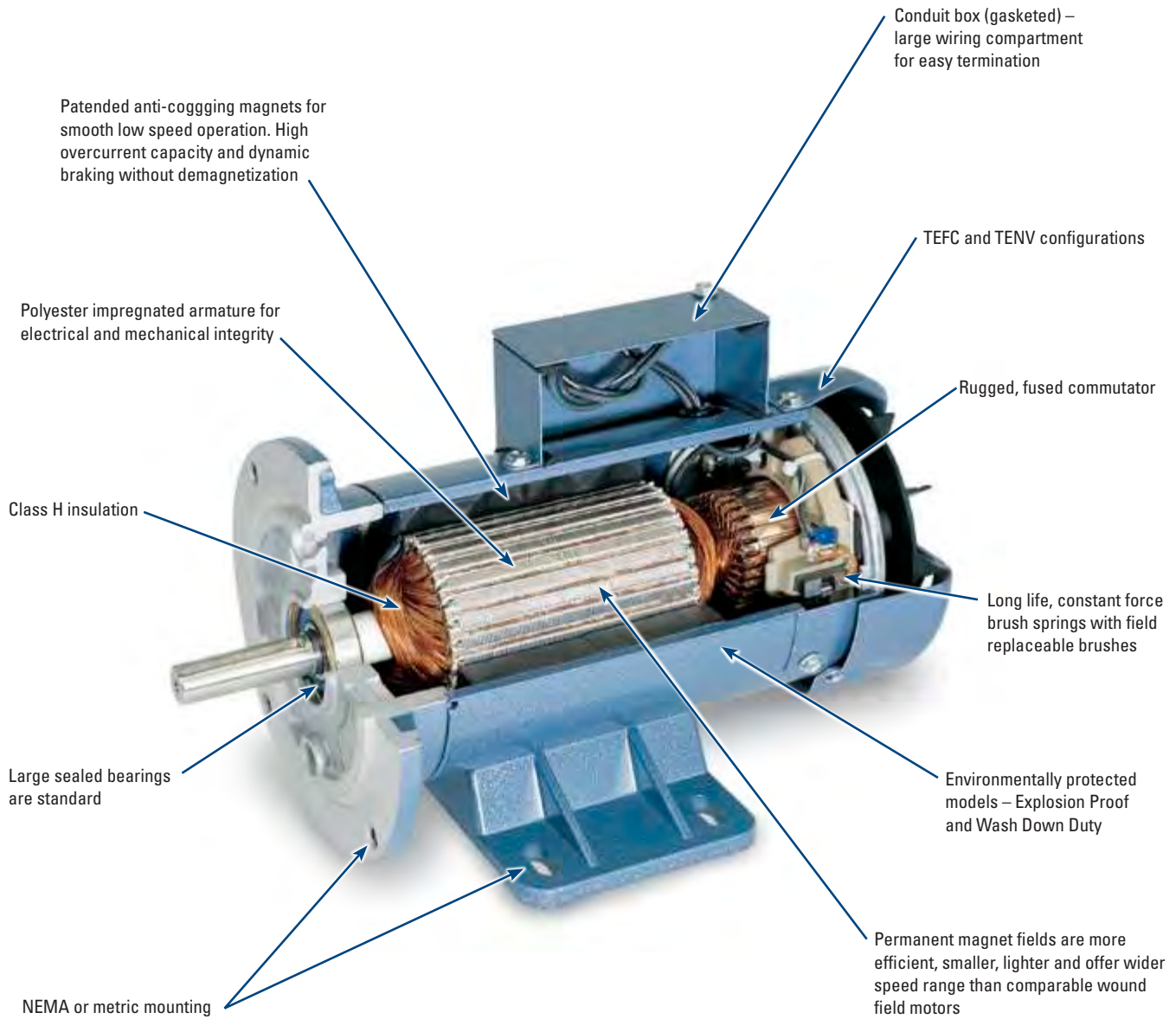

SR/SRF Series Continuous Duty Motors

General Specifications



SCR Rated NEMA Standards

- NEMA C face with removable base – except the 180 V / 1.5 HP has a welded base
- Class H insulation
- UL Recognized (UL 1004, File E61960)
- CSA Certified (CSA Standard C22.2 No. 100, Class 421101, File LR43477)
- CE marked. Conforms to EN60034-1 and EN60034-5
- 1750 RPM

	HP	Model Number	Product Code	NEMA	Enclosure	Parameters							Configuration/Dimensions (facing page)	Length (in)	Weight (lbs)	Brush Replacement (order 2 per motor)
						Continuous Current (A)	Continuous Torque (lb _f -in)	Peak Current (A)	Torque Constant (lb _f -in/A)	Resistance (Ω)	Inertia (lb _f -in)	Inductance (mH)				
90 V	1/8	SR3616-8290-7-56BC-CU	FGS2430	56C	TENV	1.5	4.5	34.0	4.0	5.3	2.9	19.4	1	8.13	14	YP00565
	1/4	SR3624-8291-7-56BC-CU	FGS2431	56C	TENV	2.7	9.0	54.0	3.9	2.5	4.0	9.6	1	9.13	18	YP00565
	1/3	SR3632-8292-7-56BC-CU	FGS2432	56C	TENV	3.5	12.0	71.0	3.9	1.8	5.0	6.6	1	10.13	21	YP00565
	1/2	SR3642-4822-7-56BC-CU	FGS2434	56C	TENV	4.7	18.0	74.0	4.2	0.9	6.5	3.8	1	12.10	17	YP00565
	1/2	SRF3632-5227-84-5-56BC-CU	FGS2748	56C	TEFC	5.1	18.0	54.0	4.0	1.3	5.2	5.8	2	10.10	22	YP00565
	3/4	SRF3650-4823-84-5-56BC-CU	FGS2749	56C	TEFC	6.9	27.0	81.0	4.2	0.7	7.8	3.7	2	13.25	30	YP00565
	1.0	SRF3765-4996-84-5-56BC-CU	FGS2751	56C	TEFC	9.5	36.0	81.0	4.4	0.5	12.8	3.4	2	13.25	30	YP00565
180 V	1/4	SR3624-1032-7-56BC-CU	FGS2658	56C	TENV	1.4	9.0	28.0	7.4	9.6	4.0	42.8	1	9.13	18	YP00566
	1/2	SR3642-4982-7-56BC-CU	FGS2438	56C	TENV	2.6	18.0	40.0	7.6	3.3	6.3	16.2	1	12.13	27	YP00566
	1/2	SRF3632-5265-84-5-56BC-CU	FGS2735	56C	TEFC	2.4	18.0	27.0	8.1	5.3	5.2	29.5	2	10.10	21	YP00566
	3/4	SRF3736-4983-84-5-56BC-CU	FGS2750	56C	TEFC	3.2	27.0	26.0	8.8	3.6	8.9	28.8	2	11.25	23	YP00566
	1.0	SRF3752-4984-84-5-56BC-CU	FGS2752	56C	TEFC	4.6	36.0	41.0	8.2	1.8	12.0	15.6	2	13.25	29	YP00566
	1.5	SRF5348-4485-84-5-45BC-CU	FGS2753	145TC*	TEFC	7.8	54.0	62.0	7.9	1.2	26.2	13.5	3	16.00	64	YP00574
	2.0	SRF5360-4985-84-5-82BC-CU	FGS2754	145TC/182	TEFC	9.5	72.0	78.0	8.2	0.6	35.9	7.0	4	16.50	75	YP00559
3.0	SRF5570-4986-84-5-82BC-CU	FGS2755	145TC/182	TEFC	14.0	108.0	78.0	9.3	0.6	40.1	7.2	5	19.75	87	YP00585	

* Stamped steel, welded base, not removable

Configurations and Dimensions (inches)

1 – TENV

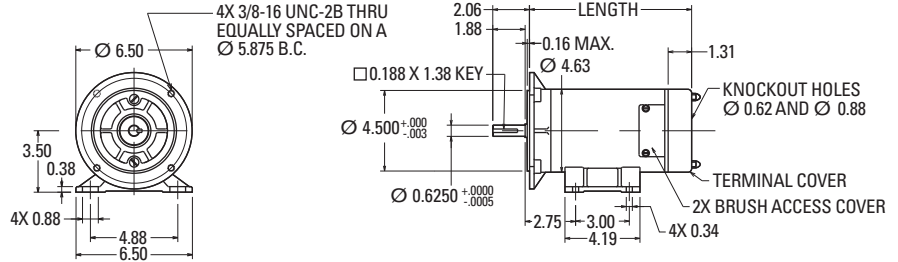

2 – TEFC

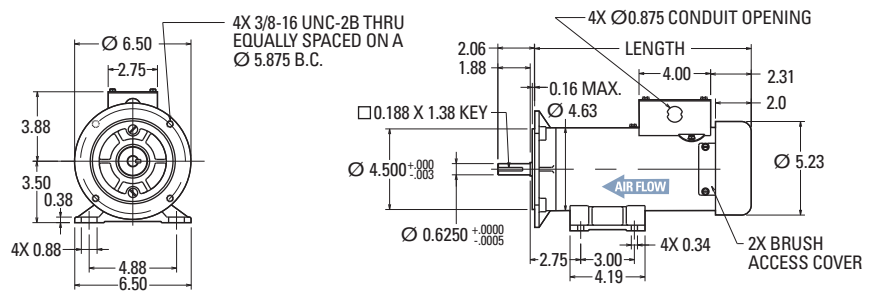

3 – TEFC

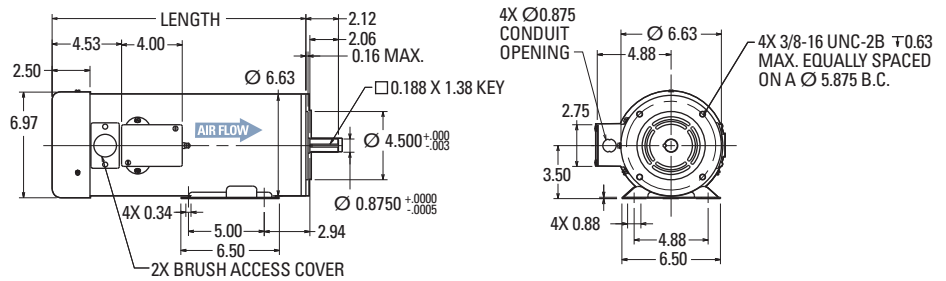

4 – TEFC

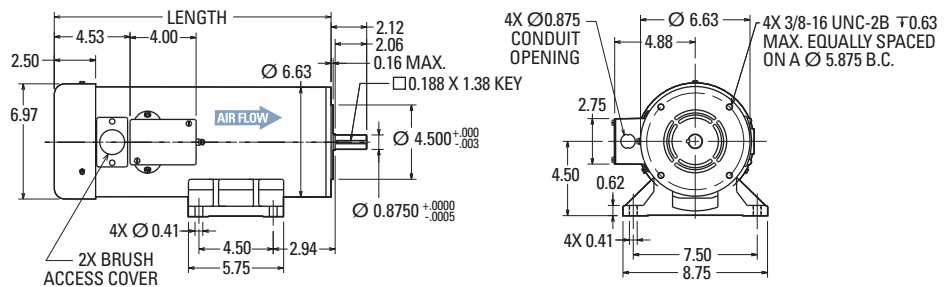

5 – TEFC

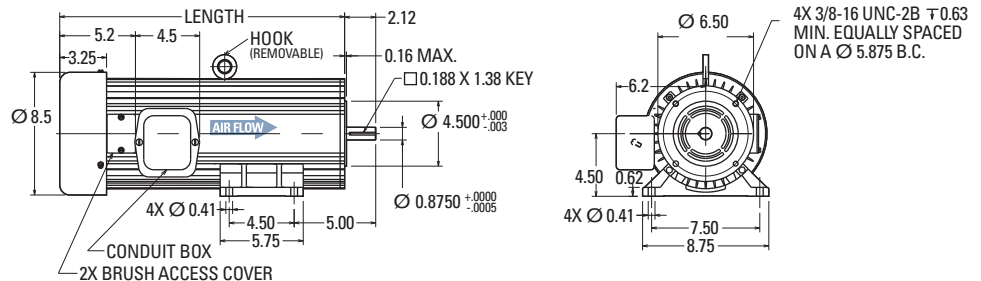

STF Series Washdown Motors

General Specifications



SCR Rated NEMA Standards – Wash Down Duty

- NEMA C face with removable base – except the 1 and 1.5 HP motors have welded bases
- Class H insulation
- UL Recognized (UL 1004, File E61960)
- Copies with NEMA MG1-1.26.5 Waterproof designation and IP65
- Bakery Industry Sanitation Standards Committee (BISSC) certified per BISSC Standard 29 (Authorization No. 301)
- 1750 RPM

	HP	Model Number	Product Code	NEMA	Enclosure	Parameters							Configuration/Dimensions (facing page)	Length (in)	Weight (lbs)	Brush Replacement (order 2 per motor)
						Continuous Current (A)	Continuous Torque (lb _r -in)	Peak Current (A)	Torque Constant (lb _r -in/A)	Resistance (Ω)	Inertia (lb _r -in)	Inductance (mH)				
90 V	1/4	STF3624-4976-61-56BC	FGS2419	56C	TENV	2.9	9.0	54.0	3.89	2.51	4.0	9.61	1	11.20	22	YP00572
	1/2	STF3640-4977-61-56BC	FGS2420	56C	TENV	5.1	18.0	67.0	4.05	0.95	6.3	4.38	1	12.20	26	YP00572
	3/4	STF3758-5150-61-56BC	FGS2757	56C	TENV	7.3	27.0	126.0	4.05	0.72	8.7	3.50	2	15.20	41	YP00572
180 V	1/2	STF3648-5268-61-56BC	FGS2738	56C	TENV	2.4	18.0	37.0	8.30	3.59	6.4	19.60	1	11.80	27	YP00571
	1.0	STF5332-3748-61-56BC-CU	FGS2389	56C*	TENV	4.6	36.0	36.0	8.00	2.40	22.4	32.00	3	13.30	41	YP00574
	1.5	STF5356-3749-61-45BC-CU	FGS2390	145TC*	TENV	7.1	54.0	70.0	7.90	1.11	29.8	11.20	4	16.30	65	YP00574
	2.0	STF5372-3750-61-82BC-CU	FGS2342	145TC/182	TENV	9.3	72.0	93.0	7.90	0.77	39.3	6.80	5	18.30	84	YP00574

* Stamped steel, welded base, not removable

Configurations and Dimensions (inches)

1 – TENV

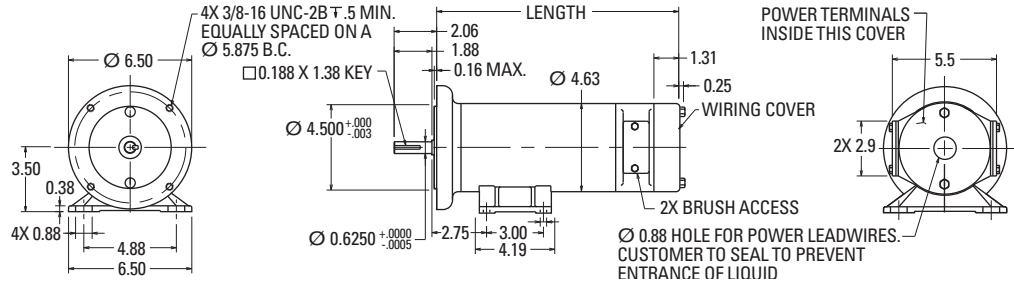

2 – TENV

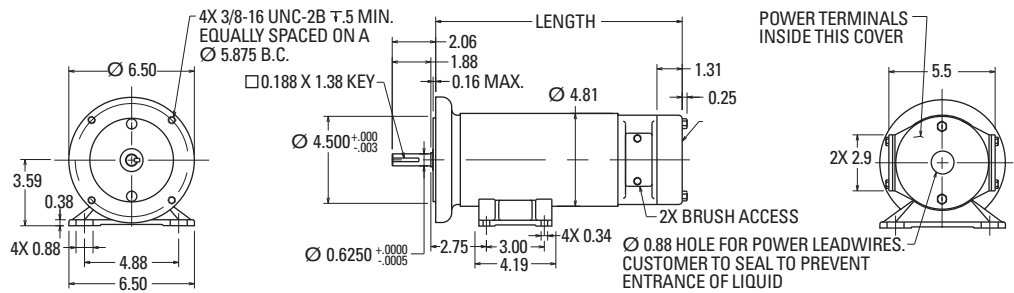

3 – TENV

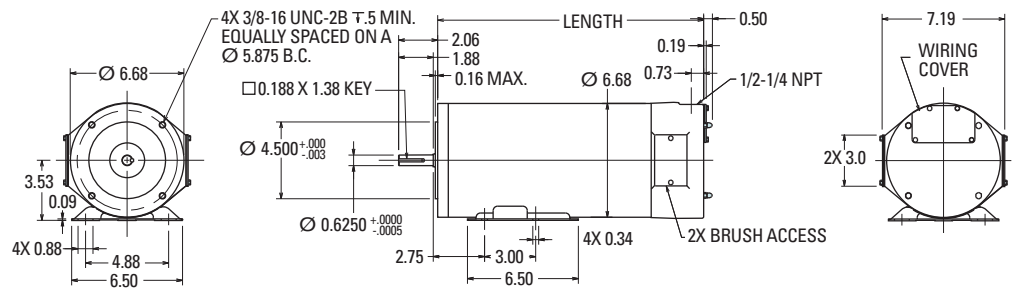

4 – TENV

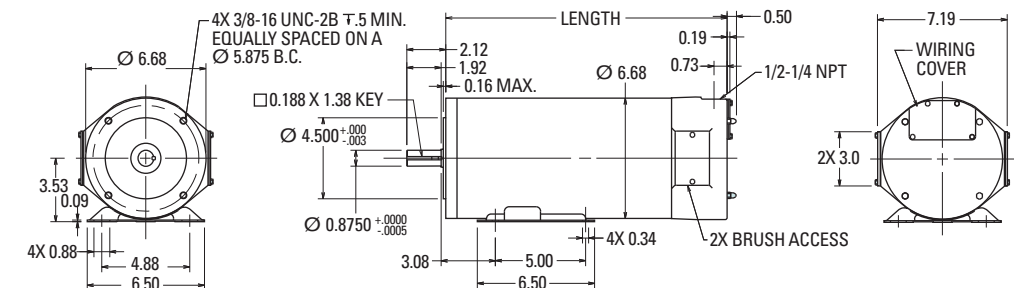

5 – TENV

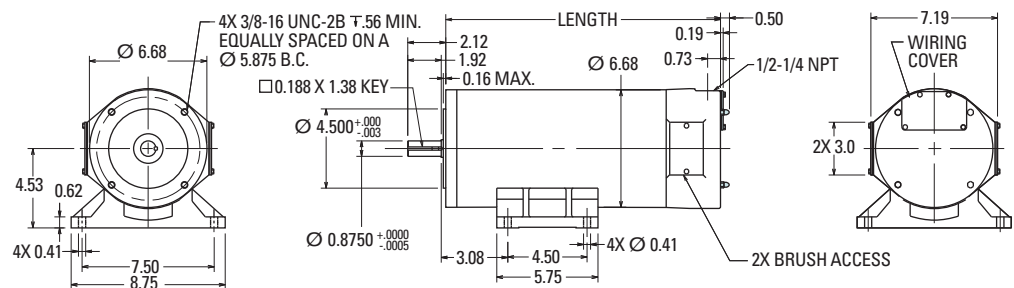

EP Series Explosion Proof Motors

General Specifications



SCR Rated NEMA Standards – Explosion Proof

- NEMA C face with removable base
- Class H insulation
- UL Recognized (UL 674, File E56538), meets Division 1 & 2, Class 1 (Groups C & D), Class II (Groups F & G) and Class III
- CSA Listed Components per CSA Standard C22.2 No. 145, Class 428801 (file 213464).
- 1750 RPM

	HP	Model Number	Product Code	NEMA	Enclosure	Parameters						Configuration/Dimensions (facing page)	Length (in)	Weight (lbs)	Brush Replacement (order 2 per motor)	
						Continuous Current (A)	Continuous Torque (lb.-in)	Peak Current (A)	Torque Constant (lb.-in/A)	Resistance (Ω)	Inertia (lb.-in)					Inductance (mH)
90 V	1/4	EP3624-1434-7-56BC-CU	FGE0212	56C	TENV	2.6	9.0	52.0	4.07	2.63	4.0	10.5	1	10.38	23	YP00565
	1/3	EP3632-1435-7-56BC-CU	FGE0242	56C	TENV	3.5	12.0	71.0	3.94	1.76	5.0	6.6	1	11.38	27	YP00565
	1/2	EP3640-1436-7-56BC-CU	FGE0213	56C	TENV	4.7	18.0	87.0	4.24	1.03	6.4	5.1	1	12.38	30	YP00565
	3/4	EP3758-5151-7-56BC-CU	FGE0248	56C	TENV	7.0	27.0	113.0	4.15	0.74	8.0	3.8	1	14.0	36	YP00565
180 V	1/4	EP3624-5269-7-56BC-CU	FGE0261	56C	TENV	1.3	9.0	26.0	8.10	10.50	4.0	51.80	1	10.38	23	YP00566
	1/2	EP36445214-7-56BC-CU	FGE0262	56C	TENV	2.3	18.0	34.0	8.10	4.00	6.7	24.20	1	12.38	30	YP00566
	3/4	EP3752-5215-7-56BC-CU	FGE0263	56C	TENV	3.3	27.0	38.0	8.10	3.10	11.4	17.40	1	14.38	34	YP00566
12 V	1/3	EP3620-1954-7-56BC-CU	FGE0243	56C	TENV	28.0	12.0	n/a	0.52	0.04	3.5	0.18	1	10.38	19	YP00583
24 V	1/3	EP3624-2757-7-56BC-CU	FGE0245	56C	TENV	13.4	12.0	n/a	1.02	0.16	4.0	0.66	1	10.38	24	YP00593
	3/4	EP3648-4952-7-56BC-CU	FGE0244	56C	TENV	28.2	27.0	n/a	1.02	0.06	7.1	0.22	1	13.38	33	YP00593

Configuration and Dimensions (inches)

1 – TENV

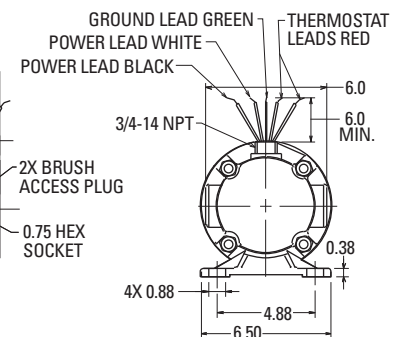
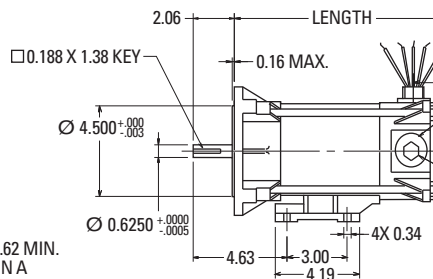
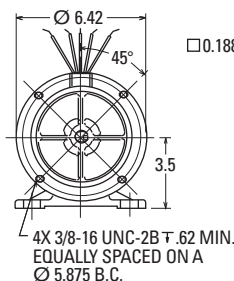

BA/BAF Series Low Voltage Motors



General Specifications

Low Voltage Rated NEMA Standards

- NEMA C face with removable base
- Class H insulation
- UL Recognized (UL1004, File E61960)
- Designed for use with low voltage supplies (batteries).
- Highly efficient
- For constant speed, motors are operated directly from a battery with no motor control interface.
- For adjustable speeds, low voltage motor controls are readily available
- 1750 RPM

	HP	Model Number	Product Code	NEMA	Enclosure	Parameters							Configuration/Dimensions (facing page)	Length (in)	Weight (lbs)	Brush Replacement (order 2 per motor)
						Continuous Current (A)	Continuous Torque (lb _f -in)	Peak Current (A)	Torque Constant (lb _f -in/A)	Resistance (Ω)	Inertia (lb _f -in)	Inductance (mH)				
12 V	1/4	BA3614-4648-9-56BC	FGB2010	56C	TENV	21.1	9.0	n/a	0.51	0.07	2.9	0.27	1	8.13	15	YP00593
	1/3	BA3624-7005-9-56BC	FGB2002	56C	TENV	27.0	12.0	n/a	0.51	0.04	4.0	0.14	1	9.13	19	YP00582
	1/2	BA3638-4588-9-56BC	FGB2005	56C	TENV	39.8	18.0	n/a	0.49	0.02	5.5	0.07	1	11.13	25	YP00592
24 V	1/4	BA3618-7009-9-56BC	FGB1592	56C	TENV	10.3	9.0	n/a	1.04	0.14	3.2	0.57	1	9.13	18	YP00593
	1/3	BA3624-7024-9-56BC	FGB2285	56C	TENV	13.4	12.0	n/a	1.02	0.16	4.0	0.66	1	9.13	19	YP00593
	1/2	BA3628-7012-9-56BC	FGB1441	56C	TENV	19.5	18.0	n/a	1.01	0.10	4.4	0.38	1	10.13	21	YP00593
	3/4	BA3648-4650-9-56BC	FGB2006	56C	TENV	28.2	27.0	n/a	1.02	0.06	7.1	0.22	1	12.10	29	YP00592
	1.0	BAF3644-5081-56BC	FGB2335	56C	TEFC	38.4	36.0	n/a	1.00	0.05	6.6	0.21	2	12.25	28	YP00583

Configuration and Dimensions (inches)

1 – TENV

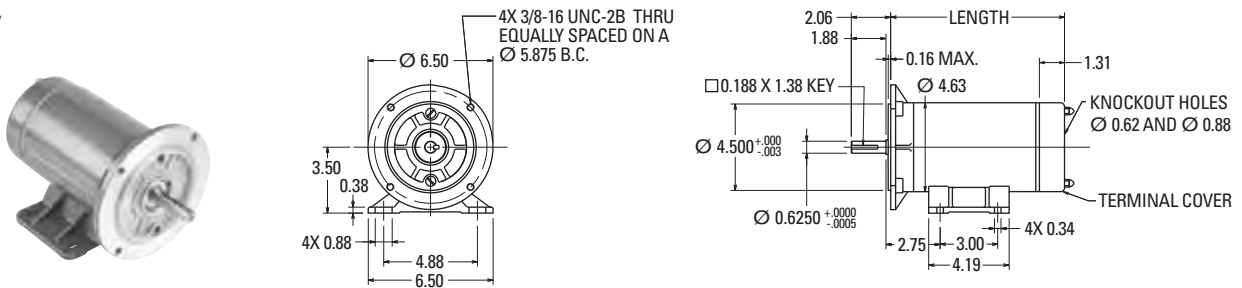

2 – TEFC

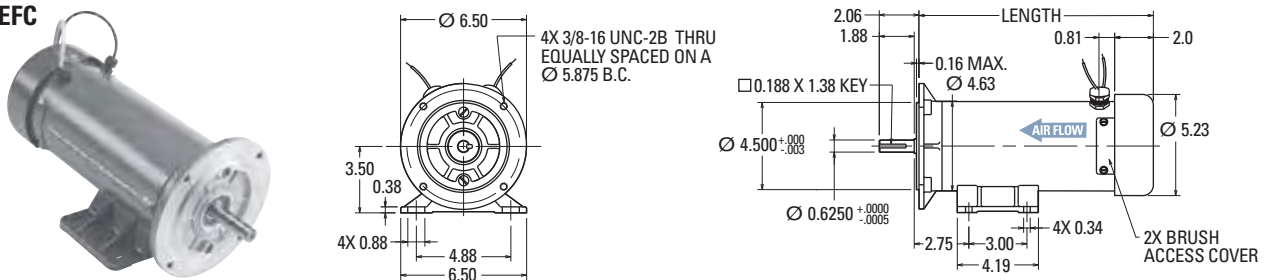

Optimized Solutions

OPTIMIZED SOLUTIONS

Applying Our Knowledge to Meet Your Motion Needs

**Optimize the
Package,
Performance
and Features**

- We provide solutions that meet your needs, including the ability to get optimum performance for the smallest package size.
- Our products deliver superior quality, through-put, efficiency, and performance.

**Reduce
Waste and
Costs**

- We have thousands of proven designs upon which to build new solutions. Our application experience expedites the design cycle, which enables you to be fully operational sooner.
- Great value is delivered in the final product.

**Meet the Most
Challenging
Requirements**

- Designs are developed for manufacturability.
- Designing and manufacturing unique products are our core competency.
- We have the broadest capabilities in the industry.



Compete and Win

Kollmorgen can translate your needs, from design to installation, into a custom motor solution that makes your end product more competitive – **driving market share and profitability for your company.**

For flexible production runs, from high volume to one piece, Kollmorgen provides on optimized solution that fits your needs – perfectly.



Optimized Solutions

Whether it's modifying a product from our standard catalog or a white sheet design for a custom solution, you can rely on decades of Kollmorgen expertise to solve your motion challenges and help your machine stand out from the crowd.

Modified Standard

Because our application expertise runs deep and our product portfolio is so broad, we can take any standard product and modify it a lot or a little to suit many needs – in a very rapid time frame. This approach ensures quality, performance and reliability by leveraging our proven track record.

Kollmorgen application engineers have a great deal of experience helping OEM engineers achieve their objectives. Typical modifications include shaft alterations, feedback type, mounting dimensions, connectors, and making components more rugged, vacuum-rated, radiation- and explosion-proof.

Custom Products

With motion as our core capability, we bring a significant history of innovation to today's engineering challenges. We leverage our design and engineering excellence and technical knowledge to deliver creative new solutions for virtually any need. Our vast experience also helps us deliver a custom product in a surprisingly short time. If you can conceive it, we can make it happen.

Dedicated Project Management

We follow a structured development process from initial concept to volume production. This enables us to provide a complete solution from design to implementation.

Our skilled engineering team is assigned to each project and ensures a high quality product designed and delivered on time, successfully taking the prototype to full production.

- Dedicated Resources & Equipment
- Real Time Customer Collaboration
- Validation of Performance, Cost & Manufacturability Before Volume Production

Customer Visibility Throughout the Entire Process

A communicative and proactive approach keeps you updated and aware of what is required throughout, what it will cost, and what to expect for design testing

This not only puts you in charge of approving any modifications before installation, but ensures the product is up and running quickly, with minimal development time and maximum value.

Engineering Excellence

What really sets us apart is our engineering expertise. With over 50 years of successfully designing custom motors, we are able to quickly assess, design and implement a solution that meets your needs.

Our engineers have an average tenure of 20 years, which means they have designed solutions for almost every unique and challenging situation. Their insightfulness and expertise will guide you through the development and implementation of an optimized motor solution.

We rely on the most advanced simulation tools to deliver the best products, designed to withstand the most unique and challenging environments:

- 3-D Modeling –ProE
- Finite Element Analysis
 - Electromagnetics
 - Structural (stress, vibration, fatigue)
 - Thermal
- Speed
- Infolytica
- Ansys
- Magneto

Why You Should Partner with Kollmorgen

- Experienced application engineers help define a customer's needs and identify the optimal Kollmorgen products and technologies
- Products optimized or developed by cross-functional teams to meet customer needs
- Rapid prototyping
- Smooth transition from prototype designs to sustainable and cost effective manufacturing
- Industry-proven quality, performance, and delivery
- Proven technology building blocks mitigate risks of customization

Custom Capabilities

OPTIMIZED SOLUTIONS

Kollmorgen offers 5-day lead-time on nearly 1,000,000 COTS products, all with best-in-class performance and quality.

When COTS is not quite the best way to realize a totally optimized system, Kollmorgen can offer co-engineered solutions to meet your most difficult challenges and advance your competitive position. Drawing on a wealth of knowledge and expertise, our engineering support team will work alongside with you to build a solution that differentiates your machine and improves your bottom line.

Here are just few examples of how Kollmorgen delivers real value to companies likes yours:

What You Need	Why Motion Matters	Kollmorgen Co-Engineering Results
30% Increase in Throughput	<ul style="list-style-type: none"> • Low inertia servo motors • High bandwidth servo loops • Simple, accurate, graphical programming tools 	Using the Kollmorgen Automation Suite™ graphical camming design tool, Pipe Network™ and low-inertia AKM servo motors, a major supplier of diabetic test labs increased throughput by more than 30% while improving accuracy and reducing scrap.
50% Increase in Accuracy and Quality	<ul style="list-style-type: none"> • Low cogging frameless servo motor • Advanced observers and bi-quad filters • Fast control loop update rates (.67µs) 	Using our AKD servo drive, a next-generation CT scanning manufacturer achieved more than 50% improvement in velocity ripple to produce the most accurate and detailed medical images possible while overcoming an extremely high moment of inertia.
25% Increase in Reliability (Overall Equipment Effectiveness)	<ul style="list-style-type: none"> • Innovative Cartridge Direct Drive Rotary™ DDR motor • Eliminating parts on the machine • No additional wearing components 	Using Kollmorgen's award-winning Cartridge DDR servomotor technology, we eliminated more than 60 parts in a die-cutting machine and increased the OEE by 25% and throughput by 20%.
50% Reduction in Waste	<ul style="list-style-type: none"> • Superior motor/drive system bandwidth • DDR technology: <ul style="list-style-type: none"> – eliminates gearbox – 20X more accurate than geared solution 	We helped a manufacturer of pharmaceutical packaging machines incorporate Housed DDR motors to increase the throughput by 35% and reduce scrap by more than 50% through more accurate alignment of the capsules.

Optimized Solutions Process

Comprehensive design, manufacture and test capabilities ensure the end product meets the customer performance specifications and quality requirements. Our skilled engineering team works directly with each customer throughout the process, quickly taking the prototype to full production.

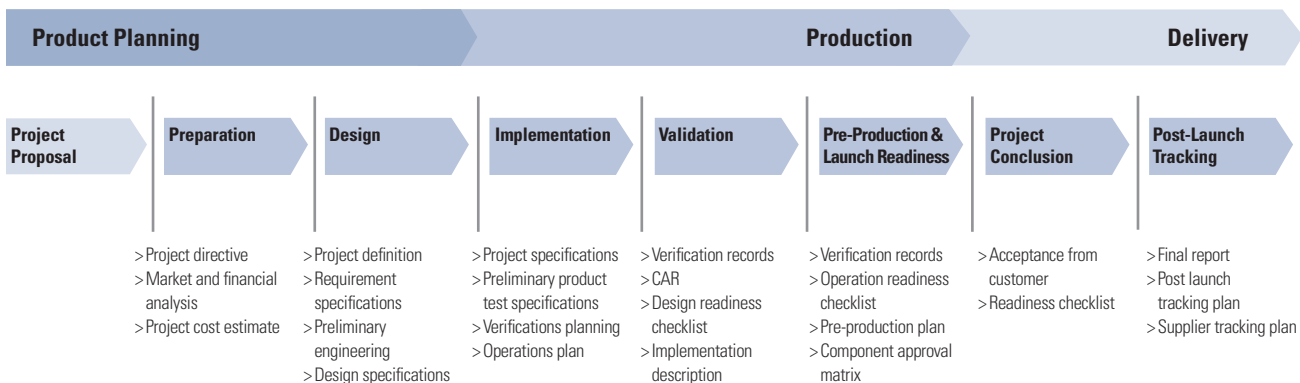

Proven Design Capabilities

Motor Solutions

- Brushed, brushless and stepper motor building blocks used in frameless or housed configurations
- Designed for agency compliance (UL, CE)
- Voltage ratings from 48 Vdc – 600 Vdc, with capabilities in 800 Vdc and up
- Continuous torques from 0.5 Nm – 29,000 Nm
- Proven performance and reliability in a customizable package

Drive Solutions

- Board-level or packaged solutions supporting single to multi-axis configurations
- Brushed or brushless servo drives, stepper, AC induction control
- Integrated controller and communications options
- Designed for agency approvals (UL 508C, EN 50178, EN 61000-6-6, EN 61800-3, CISPR 14-1, and others available)
- Proprietary technology and software can be embedded into the drive



Medical diagnostics drive optimized for form-factor, I/O and EMC

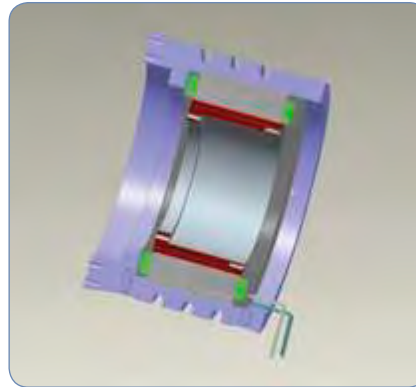

Frameless direct drive rotary motor with water cooling features

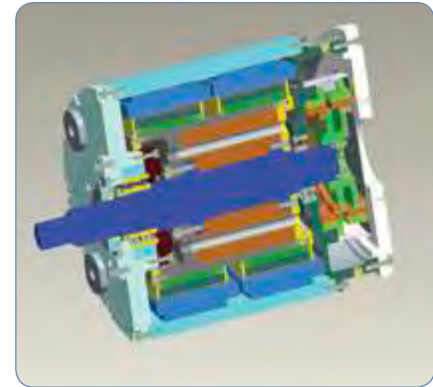

Custom submersible motor

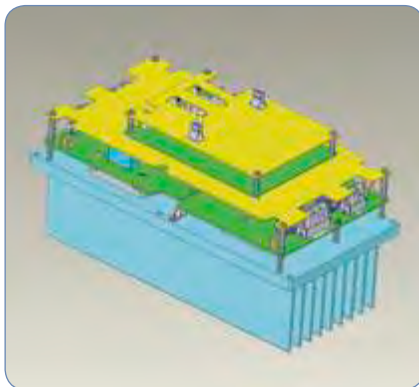

2-axis drive for high-power robotics, optimized for form-factor and communications interface



200 kW electric starter/generator

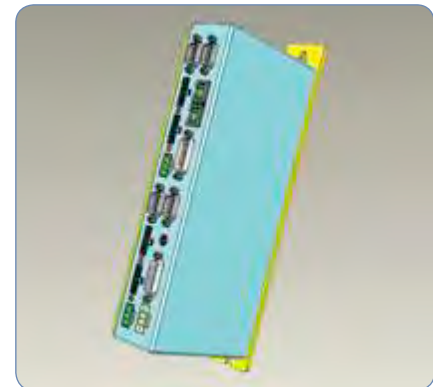

4-axis stepper drive using SynqNet

Motors and Electronics

Optimized for	Application
Reliability, weight	Implantable heart pumps, military, remote equipment
Precision	Pick and place, satellite tracking, film processing
Package size	Medical imaging, ground based telescopes, aircraft instrumentation
Smooth operation	Medical respirators, high precision robotics, printing and textile machines
Harsh environments	Deep sea, outer space, high shock and vibration, extreme temperatures

Special Duty Motors

SPECIAL DUTY MOTORS



Every day Kollmorgen pushes the boundaries of motion to deliver optimized solutions that satisfy even the most demanding application requirements in the harshest of environments.

We've been working with the biggest names in harsh and hazardous environments in Industry, Automation, Aerospace & Defense, Exploration, Nuclear, Medical and Robotics for nearly 60 years.

We are on Mars and the Moon, and on-, in-, and at the bottom of the oceans: In fact, Kollmorgen motors powered the legendary ROV Jason Jr. at a depth of 3,784 meters (12,415 feet) to explore the interior of Titanic for the first time since it sank in 1912.

Kollmorgen continues to collaborate with leading innovators with the same enthusiasm and acumen: Kollmorgen knows that motion matters and represents endless possibilities for innovation. Our engineering expertise and engineering capabilities enable us to deliver superior performing solutions for these demanding environments.

Goldline® S Series Submersible Servo Motors



These brushless servo motors incorporate pressure compensation technology to allow underwater operation up to 20,000 ft while withstanding extreme environments. They feature stainless steel and aluminum nickel bronze housings or an anodized aluminum housing for lighter overall weight. All shafts are stainless steel and sealed with an externally serviceable O-ring seal. The S Series is fully tooled for cost-effective volume production.

- Choice of stainless steel and aluminum nickel bronze housings or an anodized aluminum housing for lighter overall weight
- Stainless steel shaft with externally serviceable seal
- SEACON connectors
- Pressure compensated: 10,000 psi
- Designed to withstand severe shock and extreme environments

MX Series Hazardous Duty Motors

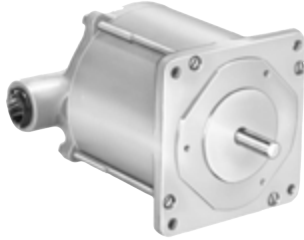

The explosion-proof MX Series provides hazardous-duty stepper motors suitable for use in Class 1, Division 1, Group D locations. They are available in NEMA 34 and 42 frame sizes (90 and 110 mm), and provide minimum holding torques from 1.27 to 9.82 N-m (180 to 1390 oz-in).

- MX09 models: NEMA 34 (90 mm) motors available in three stack lengths with minimum torque ratings from 1.27 to 3.88 N-m (180 to 550 oz-in)
- MX11 models: NEMA 42 (110 mm) motors available in 2 stack lengths with minimum torque ratings from 6.0 to 9.82 N-m (850 to 1390 oz-in)
- Speeds up to 3,000 rpm provide for velocity demands of most high torque applications

Hazardous Duty Synchronous Motors

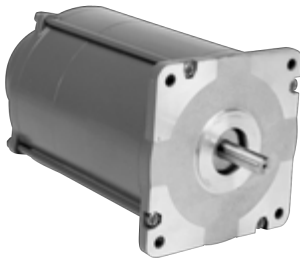

These synchronous motors are available in UL Listed versions suitable for use in Class I, Division 1, Group D hazardous locations. They provide torque up to 1,500 oz-in (1059 N-cm) and are available in NEMA 42 and 66 frame sizes (110 mm and 170 mm).

- Motor torque up to 1,500 oz-in (1059 N-cm)
- 72 rpm at 60 Hz, 60 rpm at 50 Hz
- 120 and 240 volt AC versions
- UL Listed and CE Certified versions
- UL Listed versions meet Class I, Division 1, Group D requirements
- UL Listed versions have a conduit connection
- CE Certified versions: CE 0081 Ex II 2G Ex d IIC T5
- CE Certified versions have an integral 10 ft (3 M) cable

EP Series Explosion-Proof Motors



These permanent magnet DC (PMDC) motors are SCRrated and adhere to NEMA standards. They are available in a variety of DC voltages, from 1/4 to 3/4 HP.

- Patented anti-cog magnets for smooth low speed operation
- Polyester-impregnated armature for electrical and mechanical integrity
- High overcurrent capacity and dynamic braking
- Rugged, fused commutator
- TEFC and TENV configurations
- Long life, constant force brush springs with field-replaceable brushes
- Gasketed conduit box with large wiring compartment
- Large sealed bearings, standard
- Class H insulation

EB Series High-Performance Explosion-Proof Servo Motors



Based on our 230 VAC B and M Series, the Kollmorgen EB Series provides a high-performance explosion-proof servo motor suitable for applications where flammable vapors or gases create a potentially hazardous environment. These motors have been tested and proven capable of withstanding an internal explosion without bursting or allowing ignition to reach outside the motor frame.

- 230 VAC explosion-proof (Class I, Division 1, Groups C and D)
- Tested and proven capable of withstanding an internal explosion without bursting or allowing ignition to reach outside the motor frame

Servo Drive Accessories

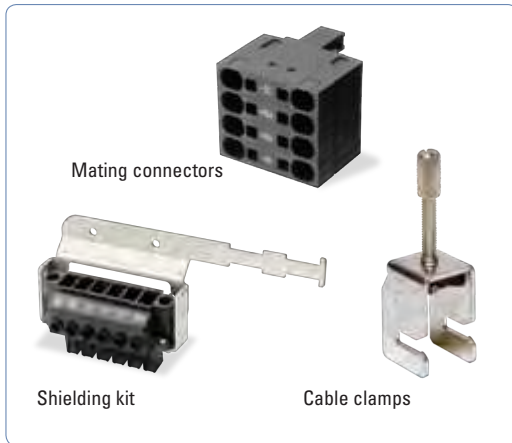

Mating Connectors and Shielding Kit

Kollmorgen's servo drives are equipped with screwable mating connectors. Alternative connectors for common DC, bus, and main ports are also available. We offer shielding kits for our flexible cables for use in environments with strong interference.



Shielding Solutions

AKD servo drives can be equipped with shielding plates.



Brake Resistors

We offer a full line of brake resistors up to 6000 watts. Brake resistors are impedance matched with AKD and are available in many sizes and form factors.



Chokes and Filters

Line filters are offered to improve reliability and to protect the life of the machine in less stable environments. Motor chokes reduce radiated emissions and are recommended for applications with cable lengths >25 meters.



Static Energy Storage

Our Static Energy Storage supplies the drive with power in the event of power outages until the machine reaches a defined state. It generates a power outage signal for evaluation by the machine control system. Simple connection to the DC intermediate circuit with two cables; immediately ready for use; no adjustment; no controls. Cascade for nearly unlimited power range



Braking Energy Storage

Our Braking Energy Storage saves Energy through Intelligent Energy Feedback. Substantial saving, especially in applications with short cycle times. Simple connection to DC intermediate circuit. Simple start-up – immediately ready for use; no adjustment; no controls. Nearly unlimited power range with expansion modules



Screw lock adapter for auxiliary connection

I/O Control Box and Breakout Adapter

Our I/O Control Box is pre-populated with I/O switches and a power connection for quicker prototyping.

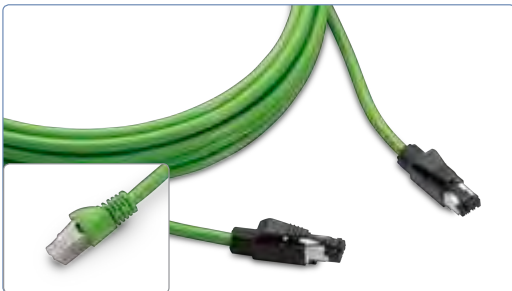

Motion Bus and Service Port Cables

We offer industrial shielded PUR cables with RJ45 connections for demanding industrial environments. These cables outperform office cables in EMC resilience, durability, and life.



CANopen Accessories

We offer cables, terminators and adapters for simple integration with CANopen machine networks.

Servo Drive Accessories

Drive System with AKD-x00306...02406

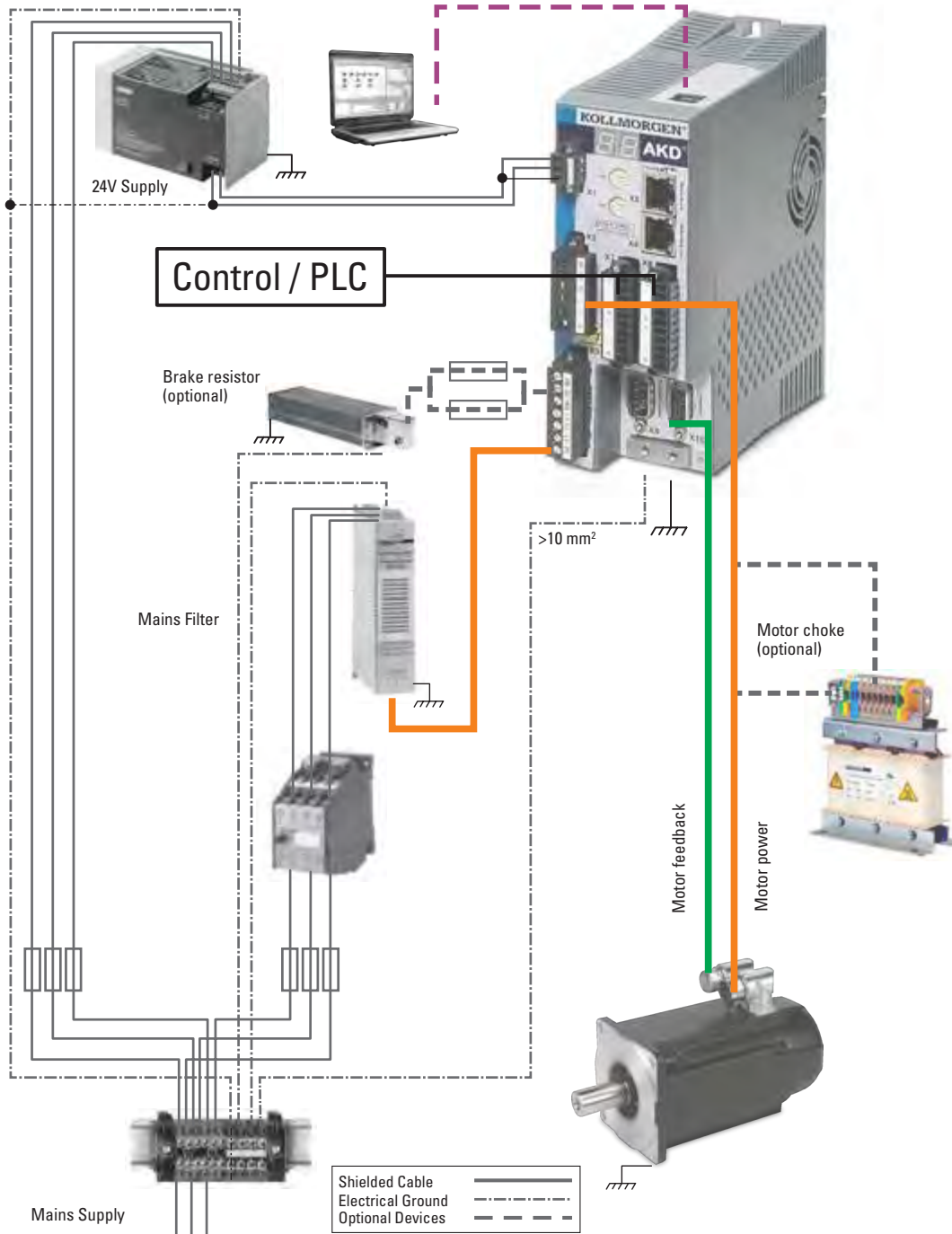

SERVO DRIVE ACCESSORIES

System Featuring AKD-N

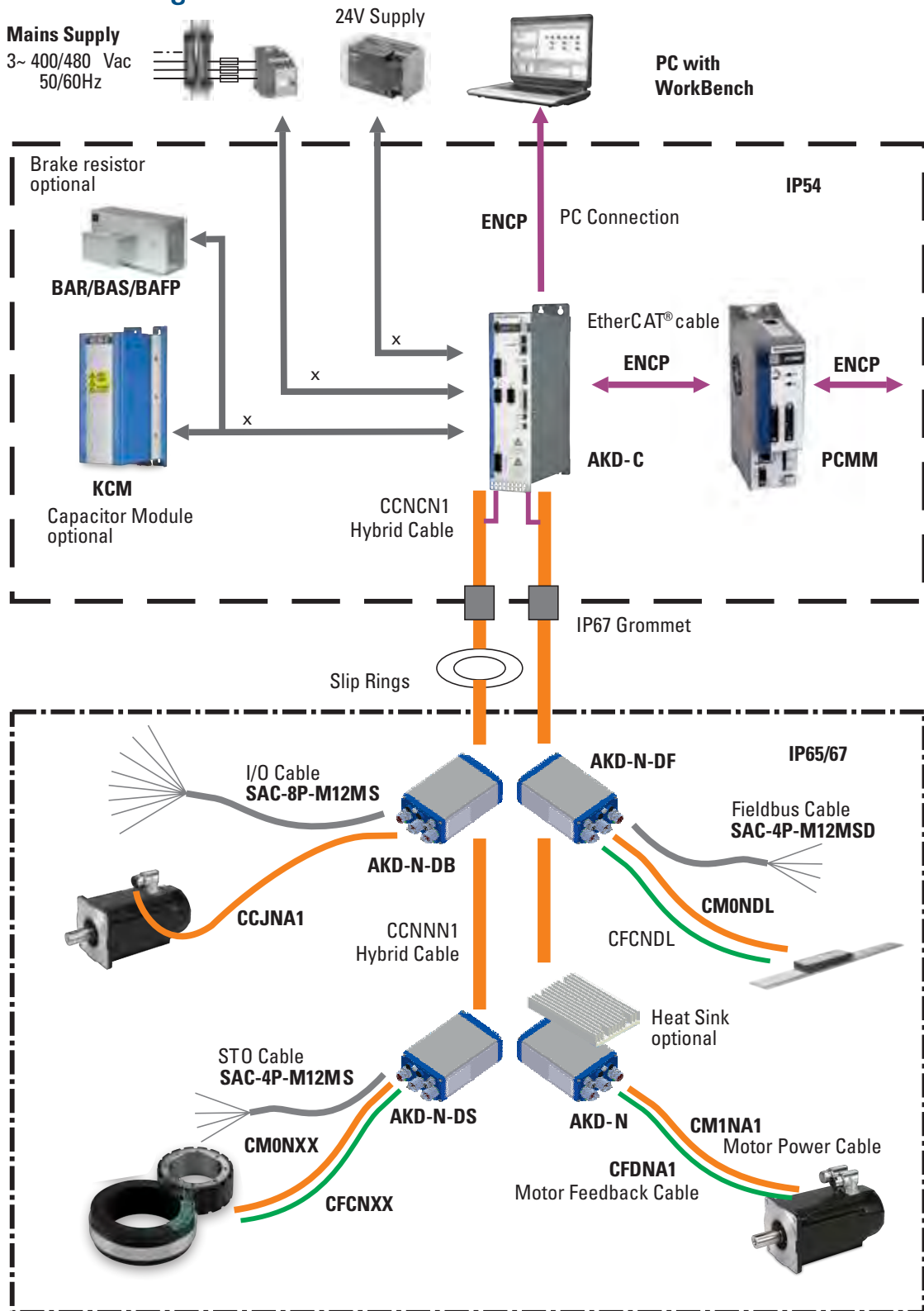

Servo Drive Accessories

SERVO DRIVE ACCESSORIES

Mechanical Accessories for Decentralized Drives (AKD-N, AKD-C)

Heat Sink for AKD-N

When mounting AKD-N to the machinery, temperature management is important to ensure maximum performance of the drive system. If needed, a heat sink may be mounted to the AKD-N.

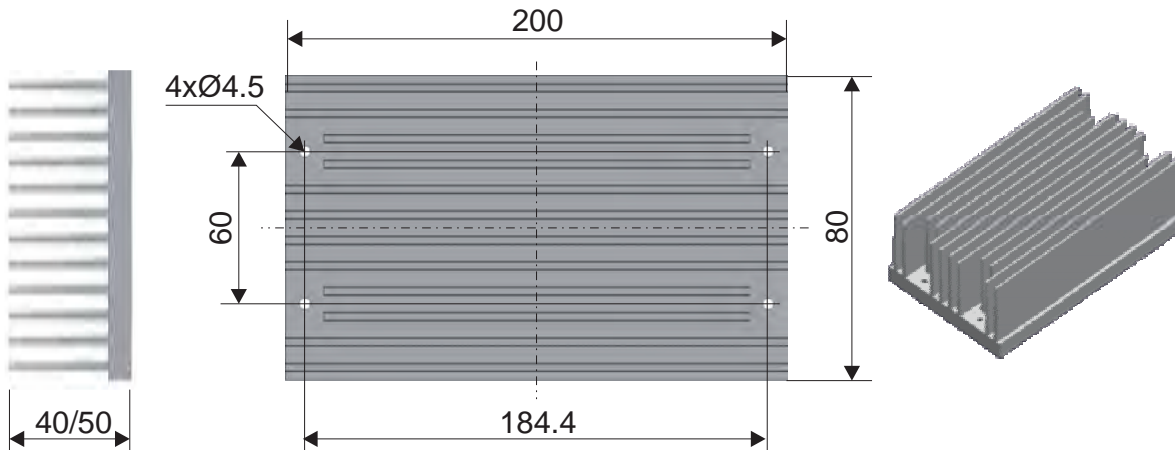

Part Number	Description
AKD-N 3,6 HEATSINK KIT 40MM	Heat sink kit 40 mm with heat conducting film and 4 screws M4x16
AKD-N 3,6 HEATSINK KIT 50MM	Heat sink kit 50 mm with heat conducting film and 4 screws M4x16
849-373001-04	Heat conducting film

Mounting clamps for AKD-N

The AKD-N drive is mounted to a machine with special mounting clamps.
 The delivery package contains 4 clamps.

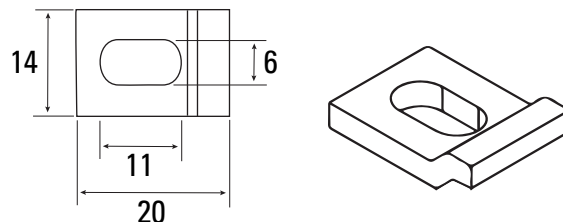

Part Number	Description
AKD-N-M/C-Set	AKD-N Mounting Clamps Set, 4 clamps

Sealing plugs for AKD-N connectors



The sealing plugs are attached to unused AKD-N connectors to ensure the IP class for the machine environment.

Part Number	Description
AKD-N-S/P-Set	AKD-N Sealing Plug Set, 4xM12, 2xM23, 2xM17

Shield Clamps



AKD drives feature slots on the front panel for the connection of additional shield clamps.

Part Number	Description	Tension Range
DE-108248	SK14	6–13mm

Jump-X5 connector for AKD-N-DS/DF with single line connection

For sufficient voltage supply of the digital feedback systems Hiperface DSL or SFD3 connected to AKD-N-DS/DF connector X4, a dongle must be plugged into X5.

Part Number	Description
AKD-N-JUMP-X5	AKD-N X5 sealed mating connector with jumper 4-5

Connector Kit for AKD-C

Mating connectors X12, X13, X14, X15, and X16 are part of delivery.

Part Number	Description
AKD-C-CONKIT	AKD-N connector kit, included mating connectors X12, X13, 14, X15, and X16

Servo Drive Accessories

Motor Chokes

General

Shielded motor cables

For reasons of electromagnetic compatibility, the motor must be supplied with power via a shielded cable. The structure of a cable with 100% shielding and the capacity equivalent circuit diagram (to earth) are shown below.

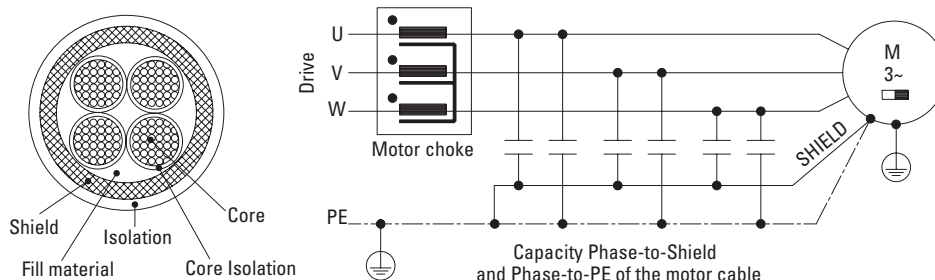

Why use motor chokes?

- To compensate high capacitive charge/discharge currents typical of shielded motor cables approximately 25 m and longer.
- To reduce current alternation noise in the motor.
- To reduce current ripple in the motor.

The digital drives high switching frequencies and steep switching edges give rise to the transfer of capacitive currents to the shield by the three phases (U, V, W). These currents flow from the shield to earth. Depending on the cable length and cable capacity (determined by design), this can lead to the generation of shield currents with peak values of up to 20 A.

These shield currents place a load on the drives and motor. On large systems, this can lead to shifts in potential which can damage other components.

This effect is evident on systems with multiple drives operating in parallel on the same mains filter.

The motor chokes slow down the rate of rise of the motor current (reduce edge steepness), thereby reducing the current transferred to the shield.

Why is the cross-section of the motor cable important?

Motor cables longer than 50 m with a small cross-section (e.g. 4 x 1.0 mm²) and therefore a higher equivalent resistance are able to reduce the oscillation tendency of the LCR oscillating circuit (drive/choke/cable/motor). This cross-section can also be advantageous for cable lengths shorter than 50 m if the cable capacity and motor inductance are very high. However, the current loading of the cable must always be within the limits specified by industry standards.

Drive*	Motor choke	Description
AKD-x003 to AKD-x006	3YLN-06	Motor cable ≥ 25m
AKD-x012	3YLN-14	Motor cable ≥ 25m
AKD-x024	3YLN-24	Motor cable ≥ 25m

*= x means variants -B, -P, -T or -

Part Number	Nominal Current	Approvals	Description
DE-107929	6 A	CE, UL	Motor choke 3YLN-06
DE-107931	14 A	CE, UL	Motor choke 3YLN-14
DE-201447	24 A	CE, UL	Motor choke 3YLN-24

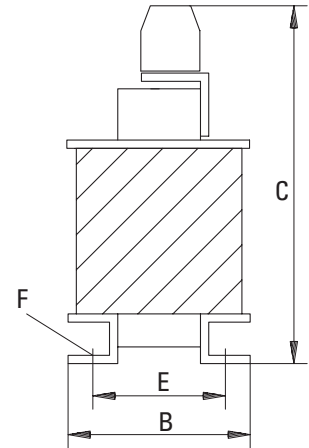
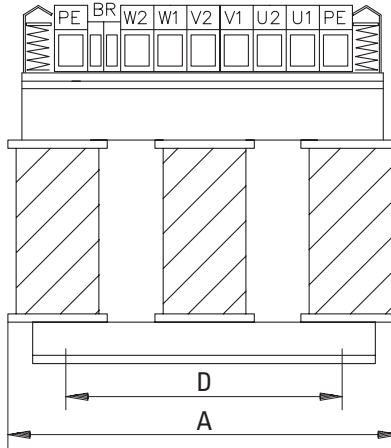

Rated Data	Sym	DIM	3YLN-06	3YLN-14	3YLN-24
Rated current	I _{0rms}	A	6	14	24
Rated voltage	U _{nom}	V	480		
Rated frequency	f _{nom}	Hz	0 to 150		
Max. frequency	f _{max}	kHz	8		
Inductivity	L	μH	900	900	450
Power loss	P	W	12	19.4	23.2
Protection class	-	-	IP00		
Temperature class	-	-	F		
Operation class	-	-	S1		
Weight	G	kg	4.5	10	10
Cable diameter (Shield clamp)	-	mm	4 to 13.5		
Wiring cross section max. (Terminals)	-	mm ²	10	16	16
Width	A	mm	155	190	190
Depth	B	mm	90	125	125
Height	C	mm	195	230	230
Mounting hole distance	D	mm	130	170	170
Mounting hole distance	E	mm	56.5	78	78
Mounting screws	F	-	4xM6	4xM6	4xM6

Servo Drive Accessories

Mains Chokes

General

In special cases, if mains voltage is more than 3% asymmetrical, then the AKD-48A must be used with a mains choke.

Purpose of mains choke:

- Prevents impermissible loading of semiconductors in the event of rapid current rise during commutation.
- Prevents voltage dips in the mains voltage caused by commutation.
- Reduces current ripple in the DC link, thereby increasing the service life of the DC link capacitors.

Drive	Mains Choke
AKD-x04807 (with asymmetrical mains >3% only)	2% uk
AKD other types	not required

Part Number	Description
DE-201476	Mains choke 3L0,24-50-2 (0.24mH, 50A)
DE-201477	Mains choke 3L0,2-75-2 (0.20mH, 75A)

Mains choke 3L

A number of drives can be connected to the same mains choke; the rated current of the mains choke must be greater than or at least equal to the total current of the connected drives.

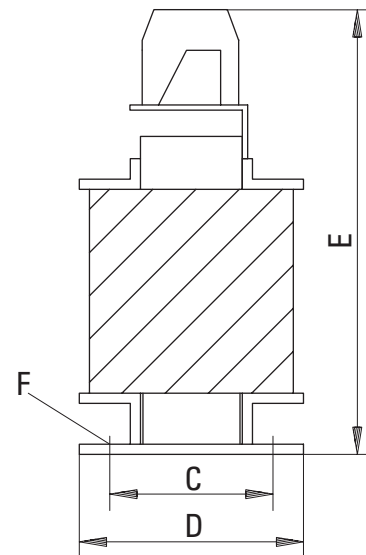
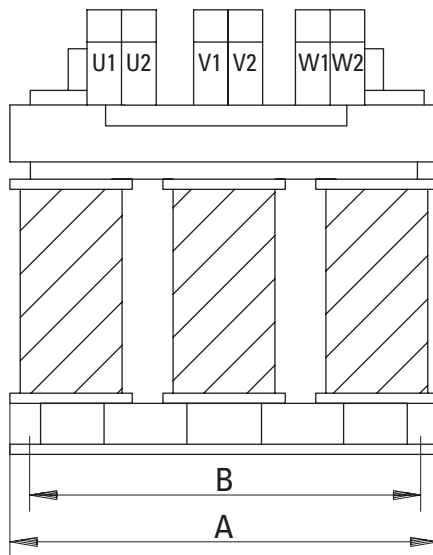
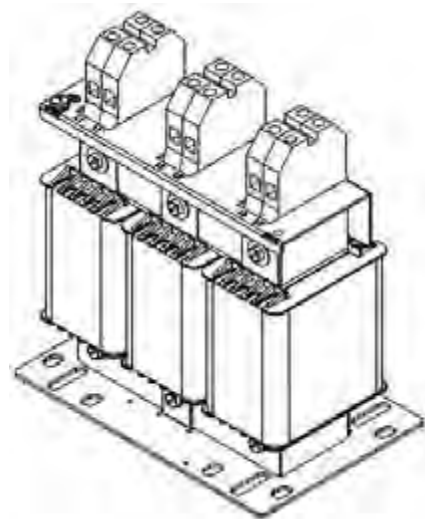

Type	Inductivity [mH]	Nominal Current [A]	uk	A [mm]	B [mm]	C [mm]	D [mm]	E [mm]	F [mm]	Terminals [mm ²]	Weight [kg]
3L 0,24-50-2	0.24	50	2%	152.5	114.3	88.9	114.3	163	6.5	10	5.9
3L 0,2-75-2	0.2	75	2%	185	170	77	122	220	8x12	35	9.9

Servo Drive Accessories

S E R V O D R I V E A C C E S S O R I E S

Mains filters

General

AKD-x00306 to AKD-x02406 drives require an external mains filter.

Drive	Mains Filter
AKD-x00307...04807 (240 to 480V)	not required
AKD-B/P/T/M 00306...02406 (120 to 240V)	1NF, 3NF

Part Number	Description
DE-201565	Mains filter 1NF-10 (230 VAC, 10A)
DE-201566	Mains filter 1NF-12 (230 VAC, 12A)
DE-201865	Mains filter 1NF-20B (125V/230 VAC, 20A)
DE-201568	Mains filter 1NF-25 (230 VAC, 25A)
DE-201569	Mains filter 3NF-07 (480 VAC, 07A)
DE-201570	Mains filter 3NF-16 (480 VAC, 16A)
DE-201571	Mains filter 3NF-30 (480 VAC, 30A)



Mains filters 1NF-10...12

Type	Nominal Current Voltage [A]*	Nominal Voltage [V]	A [mm]	B [mm]	C [mm]	D [mm]	F [mm]	M [mm]	N [mm]	P [mm]	Weight [kg]	Connection
1NF-10	10	230	85	49	40.3	54	75	5.3	6.3	87	0.29	Fast-on
1NF-12	12	230	156	57.5	45.4	130.5	143	5.3	6	156	0.73	Fast-on

* at 40°C environment temperature

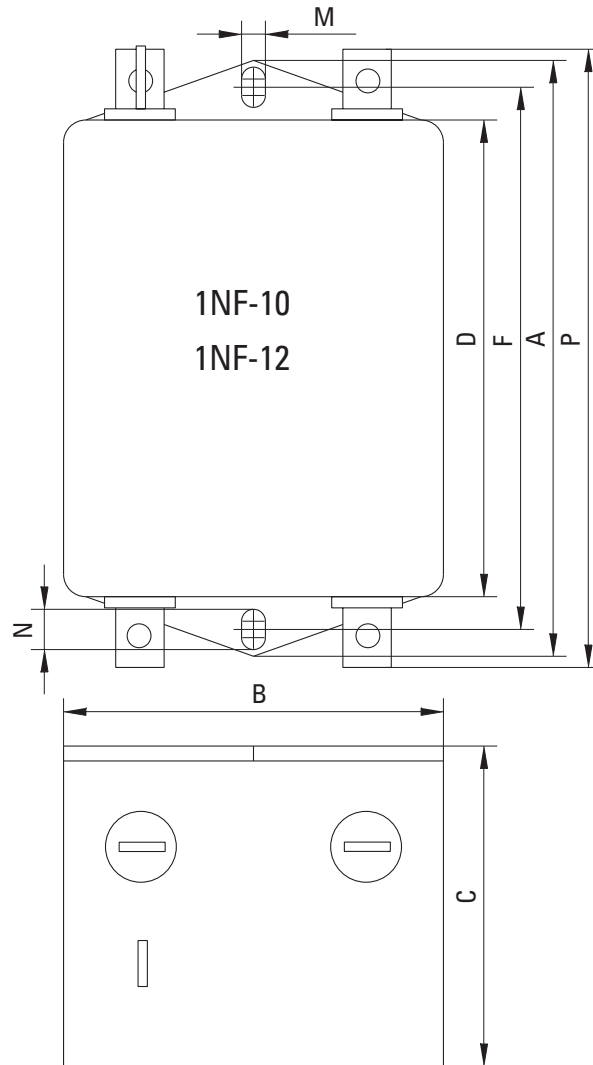

Servo Drive Accessories

SERVO DRIVE ACCESSORIES

Mains filters 1NF-20B, 1NF-25

Type	Nominal Current [A]*	Nominal IEC	Voltage UL/ CSA	Weight [kg]	Connection Phase Terminals	Connection PE
1NF-20B	20	230V	125V	0.93	Wires up to 4mm ² Torque 0.6 to 0.8 Nm	Bolt M 6 Torque 3.5 to 4 Nm
1NF-25	25	230V	230V	0.7	Wires up to 10 mm ²	

* at 50°C environment temperature

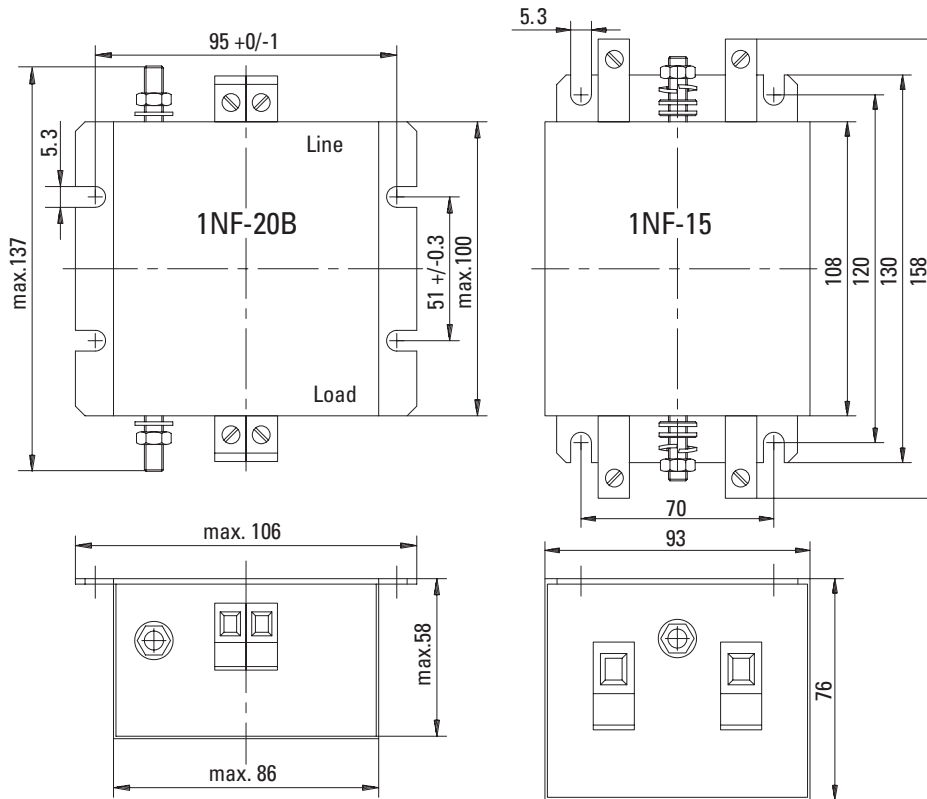

Mains filter 3NF-07...30

Type	Nominal Current [A]*	A [mm]	B [mm]	C [mm]	D [mm]	F [mm]	G [mm]	M [mm]	P [mm]	Weight [kg]	Terminals	PE Bolt
3NF-07	7 A	190	40	70	160	180	20	4.5	180	0.5	4 mm ² , 0.7-0.8 Nm	M5, 2.2 Nm
3NF-16	16 A	250	45	70	220	235	25	5.4	240	0.8		
3NF-30	30 A	270	50	85	240	255	30	5.4	260	1.2	10 mm ² , 1.9-2.2 Nm	

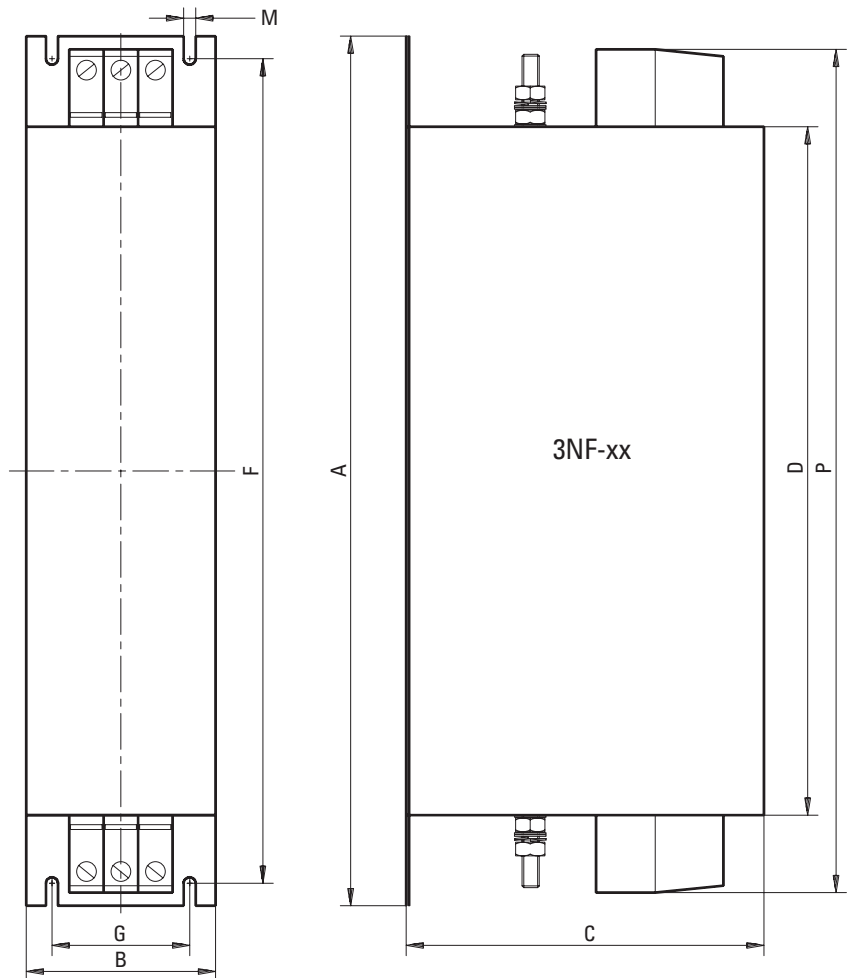

* at 50°C environment temperature

Servo Drive Accessories

Regen resistors

General

During braking, energy is fed back into the drive. This regenerative energy is dissipated as heat in the regen resistor (also known as the brake resistor). The regen resistor is switched on by the regen circuit. Different resistance values have to be used depending on the drive. All resistors meet the requirements of CE directives and are UL-registered.

Drive*	Brake resistor	Resistance Ω	Optional/Required
AKD-x00306	BAFP(U)/BAR(U)/BAS(U)	33	usually required
AKD-x00606	BAFP(U)/BAR(U)/BAS(U)	33	usually required
AKD-x01206	BAR(U)/BAS(U)	15	optional
AKD-x02406	BAR(U)/BAS(U)	15	optional
AKD-x00307	BAR(U)/BAS(U)	33	optional
AKD-x00607	BAR(U)/BAS(U)	33	optional
AKD-x01207	BAR(U)/BAS(U)	33	optional
AKD-x02407	BAR(U)/BAS(U)	23	optional
AKD-x04807	BAS(U)	10	usually required
AKD-C01007	BAR(U)/BAS(U)	33	optional

Description	Drive*	Resistance Ω	Rated Power [W]	Maximum Power [W]	Part Number
Brake resistor BAS(U) 2000-10	AKD-x04807	10	2000	3200	DE-103874
Brake resistor BAS(U) 3000-10		10	3000	4800	DE-103875
Brake resistor BAS(U) 6000-10		10	6000	9600	DE-103876
Brake resistor BAR(U) 500-15	AKD-x01206 & x02406	15	500	800	DE-201439
Brake resistor BAR(U) 1000-15		15	1000	1600	DE-201440
Brake resistor BAS(U) 2000-15		15	2000	3200	DE-103871
Brake resistor BAS(U) 3000-15		15	3000	4800	DE-103872
Brake resistor BAS(U) 6000-15	AKD-x02407	15	6000	9600	DE-103873
Brake resistor BAR(U) 600-23		23	600	960	DE-200613
Brake resistor BAR(U) 1000-23		23	1000	1600	DE-200614
Brake resistor BAS(U) 2000-23		23	2000	3200	DE-200615
Brake resistor BAS(U) 3000-23		23	3000	4800	DE-200616
Brake resistor BAS(U) 4000-23	AKD-x00306 to -x00606, AKD-x00307 to -x01207, AKD-C01007	23	4000	6400	DE-200617
Brake resistor BAFP(U) 100-33		33	100	160	DE-201437
Brake resistor BAFP(U) 200-33		33	200	320	DE-201438
Brake resistor BAR(U) 250-33		33	250	400	DE-106254
Brake resistor BAR(U) 500-33		33	500	800	DE-106255
Brake resistor BAR(U) 1500-33		33	1500	2400	DE-106258
Brake resistor BAS(U) 3000-33		33	3000	4800	DE-201407

*= AKD-x means AKD variants -B, -P, -T or -M

External Regen Resistor BAFP(U)

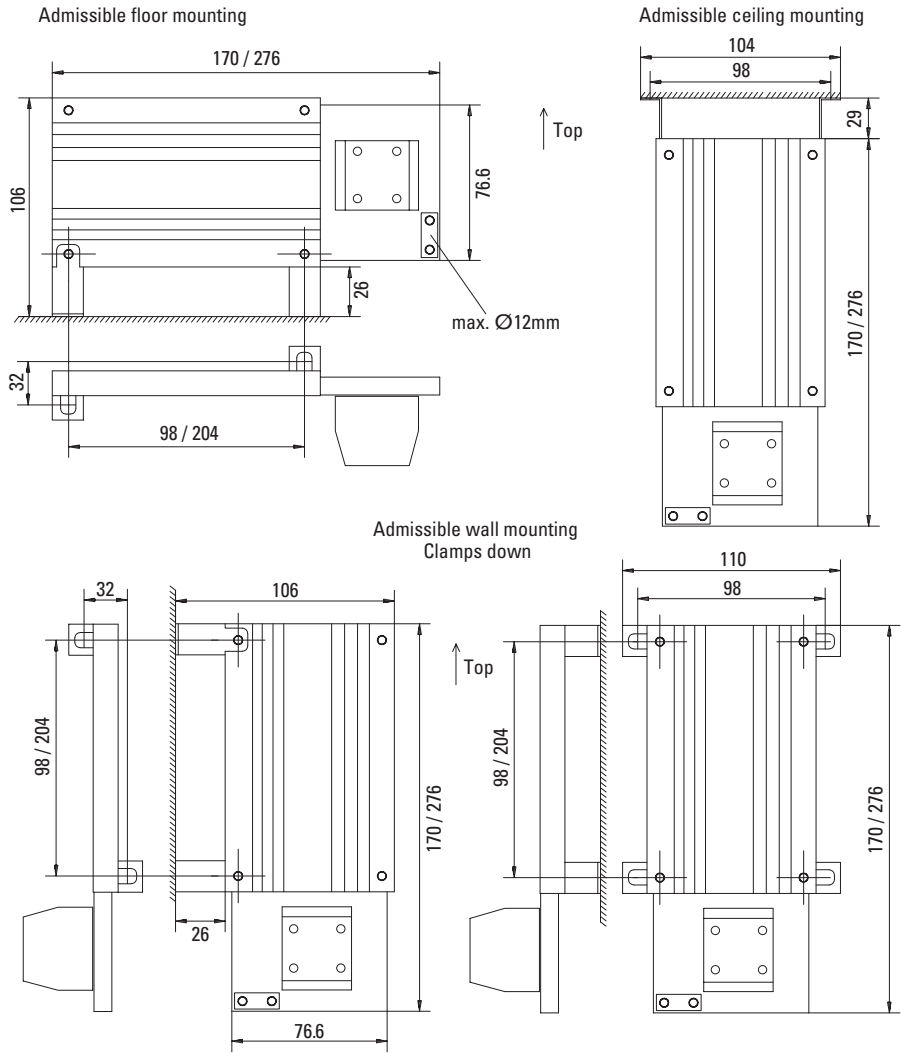

Other types of mounting are not admitted!

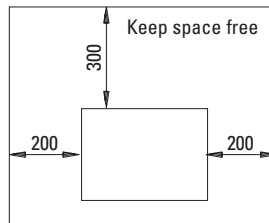

Type	R	Length	Power	Weight
	Ω	mm	W	Kg
BAFP(U) 100-33	33	170	100	0.3
BAFP(U) 200-33	33	276	200	0.55

Servo Drive Accessories

SERVO DRIVE ACCESSORIES

External Regen Resistor BAR(U)

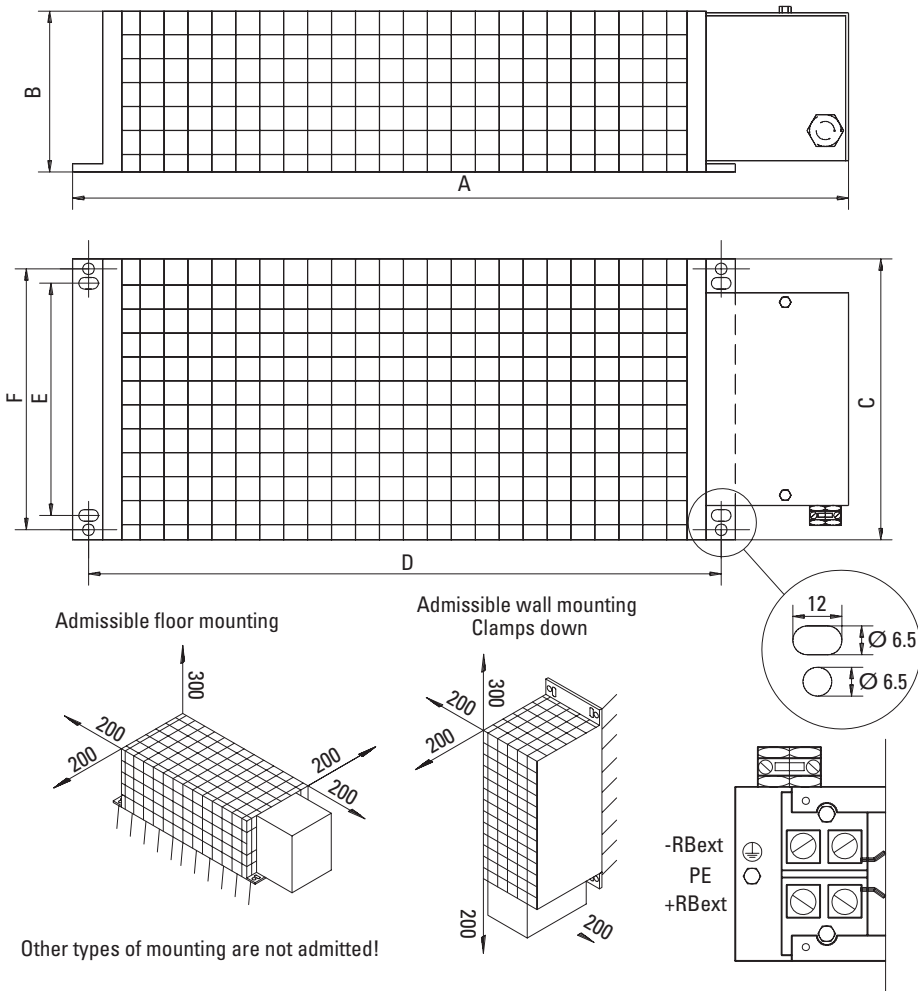

Type	R	Power	A	B	C	D	E	F	Weight
	Ω	W	mm	mm	mm	mm	mm	mm	Kg
BAR(U) 500	15	500	549	120	92	430	64	80	3
BAR(U) 1000	15	1000	749	120	92	630	64	80	4
BAR(U) 600	23	600	549	120	92	430	64	80	3
BAR(U) 1000	23	1000	749	120	92	630	64	80	4
BAR(U) 250	33	250	349	120	92	230	64	80	2
BAR(U) 500	33	500	549	120	92	430	64	80	3
BAR(U) 1500	33	1500	649	120	185	530	-	150	5.8
BAR(U) 300	66	300	349	120	92	226	64	80	1.5
BAR(U) 600	66	600	549	120	92	426	64	80	2.3
BAR(U) 1000	66	1000	749	120	92	626	64	80	3.4
BAR(U) 300	91	300	349	120	92	226	64	80	1.5
BAR(U) 600	91	600	549	120	92	426	64	80	2.3
BAR(U) 1000	91	1000	749	120	92	626	64	80	3.4

±10%, temperature drift approx. 1%
 Cold approx. +6%, 320° C approx. -7%

External Regen Resistor BAS(U)

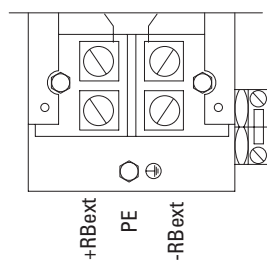
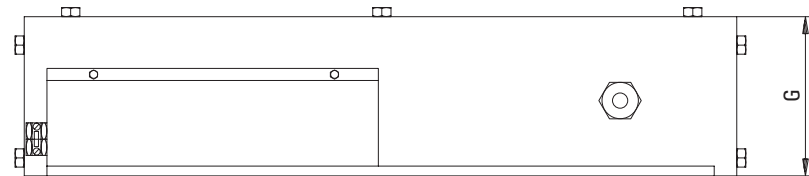
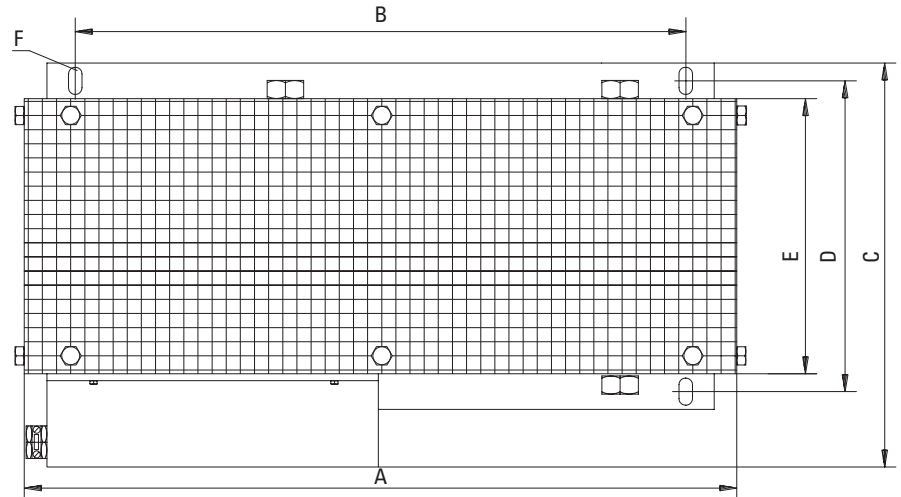

Admissible floor mounting

Admissible wall mounting
Clamps down

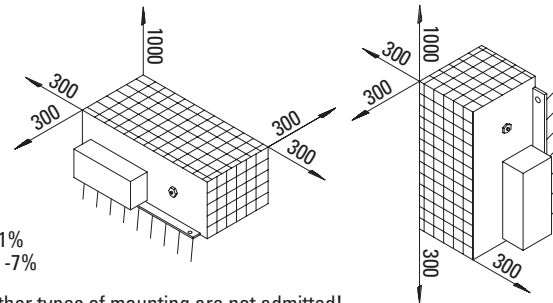

±10%, temperature drift approx. 1%
 Cold approx. +8%, 320°C approx. -7%

Other types of mounting are not admitted!

Type	R	Rated Power	A	B	C	D	E	∅ F	G	Weight
	Ω	W	mm	mm	mm	mm	mm	mm	mm	Kg
BAS(U)2000-10	10	2000	490	380	255	170	150	10.5	260	7
BAS(U)3000-10	10	3000	490	380	355	270	250	10.5	260	8
BAS(U)6000-10	10	6000	490	380	455	370	350	10.5	260	11
BAS(U)2000-15	15	2000	490	380	255	170	150	10.5	260	7
BAS(U)3000-15	15	3000	490	380	355	270	250	10.5	260	8
BAS(U)6000-15	15	6000	490	380	455	370	350	10.5	260	11
BAS(U)2000-23	23	2000	490	380	255	170	150	10.5	260	7
BAS(U)3000-23	23	3000	490	380	355	270	250	10.5	260	8
BAS(U)4000-23	23	4000	490	380	355	270	250	10.5	260	9
BAS(U)3000-33	33	3000	490	380	355	270	250	10.5	260	8

Servo Drive Accessories

Capacitor Modules

General

KCM modules (**K**OLLMORGEN **C**apacitor **M**odules) absorb energy generated by the motor when it is operating in generator mode. Normally, this energy is dissipated as waste via regen resistors. KCM modules, however, feed the energy they have stored back into the DC Bus link as and when it is required.

KCM-S	Saves energy: The energy stored in the capacitor module during generative braking is available the next time acceleration happens. The module's inception voltage is calculated automatically during the first load cycles.
KCM-P	Power in spite of power failure: If the power supply fails, the module provides the drive with the stored energy that is required to bring the drive to a standstill in a controlled manner (this only applies to the power supply voltage; battery-back the 24 V supply separately).
KCM-E	Expansion module for both applications. Expansion modules are available in two capacitance classes.

The KCM modules may only be connected to drives with 400/480 V rated voltage.

Drive*	KCM Module	Voltage
AKD-x00306...02406	not allowed	240 V
AKD-x00307...02407	all modules	480 V
AKD-x04807	contact customer support	480 V
AKD-C01007	all modules	480 V

*= x means variants -B, -P, -T or -M

Part Number	Description
KCM-S200-0000	Energy Saving Module, 1.6 kW
KCM-P200-0000	Power Module, 2 kW
KCM-E200-0000	Expansion Module 2 kW
KCM-E400-0000	Expansion Module 4 kW

KCM Module

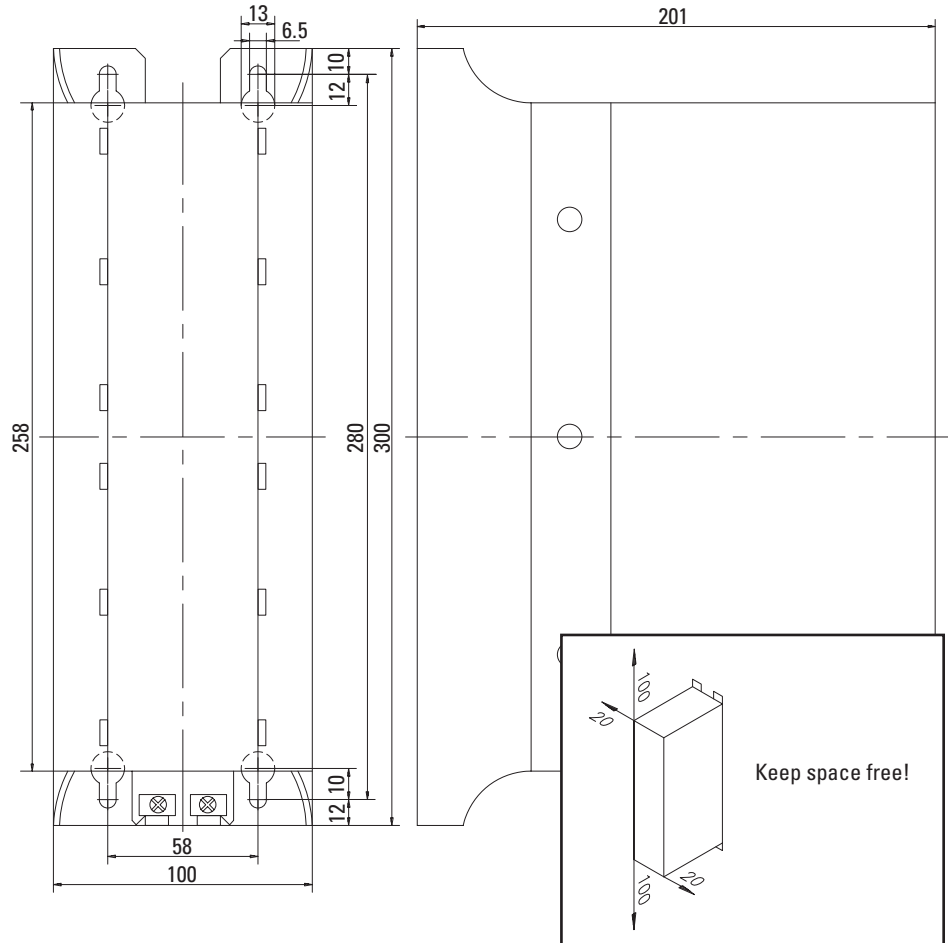

Type	Storage Capacity [Ws]	Rated supply [V=]	Peak supply [V=]	Power [kW]	Protection Class	Inception Voltage [V=]	Weight [kg]
KCM- S200	1600	max 850 VDC	max 950VDC (30s in 6min)	18	IP20	calculated	6.9
KCM- P200	2000					470 VDC	6.9
KCM- E200	2000					-	4.1
KCM- E400	4000					-	6.2

Servo Drive Accessories

AKD Performance Cables

Hybrid Cables

Hybrid cables offer a single connection point on the motor for both feedback and power. Feedback options for this connection type are:

- SFD GEN3 (Single-turn absolute, CA option)
- HiPerFace DSL (Single-turn absolute, GE option)
- HiPerFace DSL (Multi-turn option, GF option)

Washdown versions of this cable are also available.

AKD Hybrid Cables by Motor Type

Motor	Hybrid Cable ¹ option for 240V drives (AKD-xxxx06xxxx)	Hybrid Cable ¹ option for 480V drives (AKD-xxxx07xxxx)
AKM < 12 A	CCJ1A2-015	CCJ2A2-015
12 A ≤ AKM < 20 A	CCJ2A2-025	CCJ2A2-025
Washdown AKM < 12 A	WCJ1A1-015	WCJ2A1-015
12 A ≤ Washdown AKM < 20 A	WCJ2A1-025	WCJ2A1-025

¹ Hybrid cables support SFD GEN 3, Single-turn and Multi-turn HiPerFace DSL

Dual Cables

Dual cables are used to separate power and feedback. Options included in this catalog support:

- HiPerFace (Single-turn absolute, GJ option)
- HiPerFace (Multi-turn absolute, GK option)
- EnDat (Single-turn, LA option)
- EnDat (Multi-turn, LB option)
- BiSS (Single-turn absolute, AA option)
- BiSS (Multi-turn absolute, AB option)

Motor	Power Cable	Power Cable with Brake	SFD	EnDat 2.2, 01& BiSS
AKM < 12 A	CP-507CCAN	CP-507CDAN	CF-DA0374N	CF-SB7374N
12 A ≤ AKM < 20 A	CP-507DCAN	CP-507DDAN	CF-DA0374N	CF-SB7374N
20 A ≤ AKM < 24 A	CP-508EDBN	CP-508EDBN	CF-DA0374N	CF-SB7374N
CDDR < 12 A	CP-507CCAN	N/A	N/A	CF-SB7374N
12 A ≤ CDDR < 20 A	CP-508DCAN	N/A	N/A	CF-SB7374N
20 A ≤ CDDR < 48 A	CM-13A4-010	N/A	N/A	CF-SB7374N
DDR < 12 A	CP-507CCAN	N/A	N/A	CF-SB7374N
12 A ≤ DDR < 20 A	CP-508DCAN	N/A	N/A	CF-SB7374N

Note: See page 177 for AKD Feedback and Power Cable nomenclature.

AKD Value Line Cables

Value Line Cables are alternative cable options suitable for most applications. These cables separate power and feedback. Options included in this catalog support Single-turn (GJ) and Multi-turn (GK) for AKD.

Motor	Power Cable	Power Cable with Brake	SFD	EnDat 2.2, 01& BiSS
AKM < 6 A	VP-507BEAN	VP-508CFAN	VF-DA0474N	VF-SB7374N
6 A ≤ AKM < 12 A	VP-508CEAN	VP-508CFAN	VF-DA0474N	VF-SB7374N
12 A ≤ AKM < 20 A	VP-508DEAN	VP-508DFAN	VF-DA0474N	VF-SB7374N
CDDR < 12 A	VP-507BEAN	N/A	N/A	VF-SB7374N
12 A ≤ CDDR < 20 A	VP-508CEAN	N/A	N/A	VF-SB7374N
20 A ≤ CDDR < 48 A	VP-508DEAN	N/A	N/A	VF-SB7374N
DDR < 12 A	VP-507BEAN	N/A	N/A	VF-SB7374N
12 A ≤ DDR < 20 A	VP-508CEAN	N/A	N/A	VF-SB7374N
12 A ≤ DDR < 20 A	VP-508DEAN	N/A	N/A	VF-SB7374N

Note: See page 177 for AKD Feedback and Power Cable nomenclature.

Servo Drive Accessories

AKD-N Performance Cables



Digital I/O cable for AKD-N

All AKD-N drives have one 8 poles M12 connector to connect digital control signals.

Drive	Part Number	Description
AKD-N (all)	SAC-8P-M12MS	5 m, M12 mating connector, unconfigured wires



STO Cable for AKD-N-DS

AKD-N-DS drives (devices with local STO input) have an additional 4 poles M12 connectors to connect the local STO signals.

Drive	Part Number	Description
AKD-N-S	SAC-4P-M12MS	5 m, M12 mating connector, unconfigured wires, A- coded



Fieldbus cable for AKD-N-DF

AKD-N-DF drives (devices with local fieldbus input) have an additional 4 poles M12 connectors to connect the local fieldbus signals.

Drive	Part Number	Description
AKD-N-DF	SAC-4P-M12MSD/5.0	5 m, M12 mating connector, unconfigured wires, D- coded

AKD-N Performance Cables



Hybrid Cable Connecting AKD-C Power Supply to AKD-N Axis Module

Part Number	Description
CCNCN1-025-xxmyy-00	Hybrid cable connecting AKD-C to AKD-N

Length definition: xx=meters, yy=centimeters



Hybrid Cable Connecting AKD-N Axis Module to AKD-N Axis Module

Part Number	Description
CCNNN1-025-xxmyy-00	Hybrid cable connecting AKD-N to AKD-N

Length definition: xx=meters, yy=centimeters



Hybrid Cable Connecting AKD-N Axis Module to AKM Motor

Part Number	Description
CCJNA3-015-xxmyy-00	Hybrid cable connecting AKD-N to AKM (SFD GEN3, Single-turn/Multi-turn HiPerFace DSL)

Length definition: xx=meters, yy=centimeters

Servo Drive Accessories

SERVO DRIVE ACCESSORIES

Performance Cables for AKD-N-DF/DS to AKM Motor



Motor	Connector	Power Cable	Power Cable with Brake	SFD
AKM < 6 A	y-tec	CM0NA3	CM1NA3	CFSNA3
	Dual Interconnect	CM0NA1	CM1NA1	CFSNA1

CAN bus cable



Configured CAN bus cables for AKD-xyyyz-xxCN and AKD-xyyyz-xxCC.

Part Number	Description
CBP000-002-m15-00	CAN bus cable 0.15 m
CBP000-002-m30-00	CAN bus cable 0.30 m
CBP000-002-001-00	CAN bus cable 1.00 m
CBP000-002-003-00	CAN bus cable 3.00 m

The CAN Termination connector is required for bus termination of the last AKD connected to the CAN bus. For connecting an AKD to a CAN device with SubD9 connector the CAN RJ12-SubD9 adapter can be used.

Part Number	Description
AKD-CAN-Termination	CAN Termination connector
AKD-CAN-RJ12-SubD9	CAN RJ12->SubD9 adapter

Notes

A large grid of graph paper for taking notes, consisting of approximately 30 columns and 40 rows of small squares.

Warehouse (NDC) Solutions

Kollmorgen is a world-leading provider of vehicle automation kits. We combine a complete range of hardware, software and navigation technologies with vast knowledge and experience. We have a long and successful history in this field and can provide you with everything you need for excellent vehicle control independent of application. The result is lower total costs – for you and your customers.

Turn to us when you want to create vehicle solutions that give you a competitive advantage in the marketplace.

Benefits

- Lowest total cost for partners

- Lowest total cost for end-users

Features

- No need to develop your own controls
- More time to focus on end-user application
- Proven and flexible concept
- Works for all applications in all segments
- Support in the sales process
- Access to value-adding services
- Customized application
- Easy to integrate with other systems
- Easy to operate, maintain and update
- High availability – 24/7 operation

AGV Control Systems

Powerful Software Solutions for Efficient Design and Service

NDC Solutions gives you access to a set of efficient design and service tools. The design tools help you outline all kinds of layouts as well as system and vehicle applications. Service tools include vehicle maintenance (e.g. fault-tracing, statistics and software downloads) and automatic surveying of the environment.

AGV CONTROL SYSTEMS

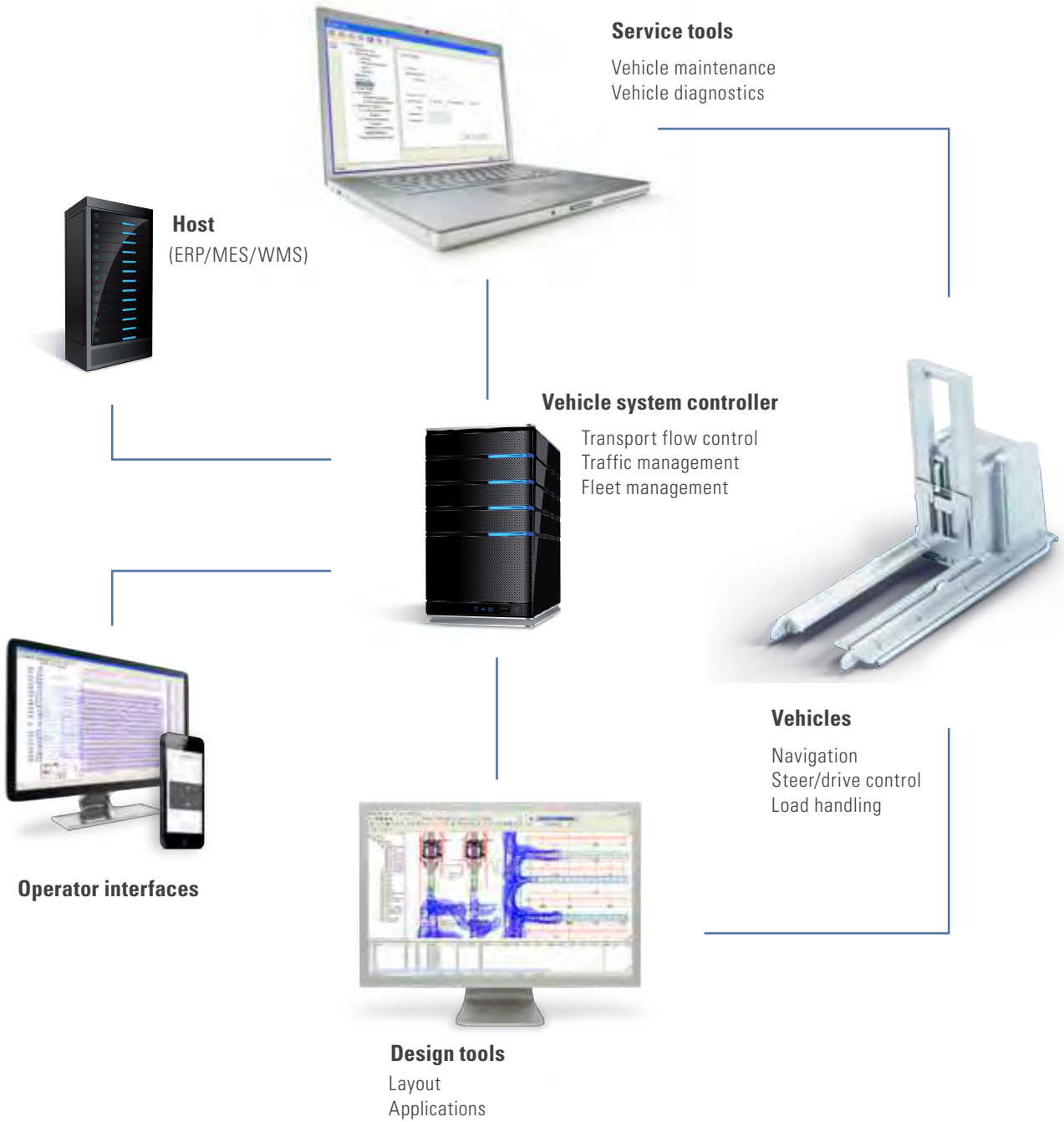

Robust and Reliable Vehicle Hardware

The different platforms in NDC Solutions use the same vehicle hardware. The hardware consists of powerful and reliable components in a number of areas. All components are designed for tough environments where vibrations, dust, moisture and temperature variations are all part of daily life.



Safety sensors



Navigation sensors



Vehicle I/O



Vehicle controllers



Displays



Drives



Encoders



Manual control device

AGV Control Systems

Navigation Technologies

NDC Solutions works with all established navigation technologies. What's more, there is also support for a combination of technologies, so-called multi-navigation. Good, for example, if you want to serve a storage space using one type of navigation and a production area using another.

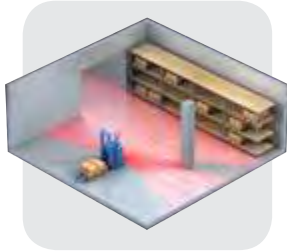

Natural

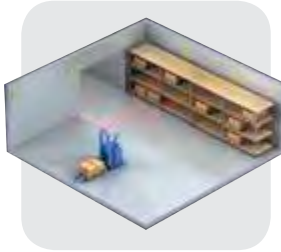

Laser

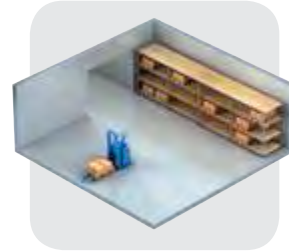

Spot

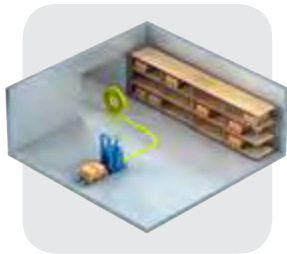

Magnetic tape

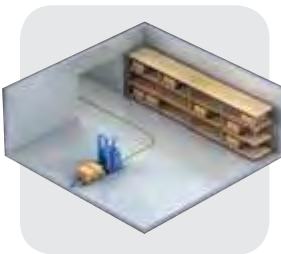

Inductive wire

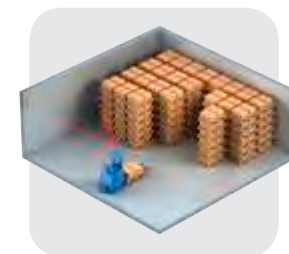

Multi-navigation

Kollmorgen - A Partner You Can Trust

With an installed base of 17.000 vehicles, Kollmorgen is the number one provider of vehicle automation kits.



World's first automobile production plant with driverless vehicles
 Volvo, Sweden, 1972



World's first laser-guided vehicle
 Tetra Pak, Singapore, 1990



World's first Pick-n-Go system
 Marktkauf, Germany, 2007



World's first driverless vehicle with 16 controlled wheels,
 Posco Steel, South Korea, 2009

Services that Last a Lifetime

The end-users require high uptime, efficient daily operations and applications that are easy to change. We help you meet these demands with both technology and services.

Our services portfolio consists of:

- Training services that quickly make you an NDC Solutions expert. We offer basic, advanced and tailor-made courses, either at our training facilities or at your site. Internet-based training is also available.
- Support services where we give answers and solutions to your requests.
- Consulting services where our senior consultants help you in the sales and design process.

The illustration shows how we support you throughout the lifecycle of your system.

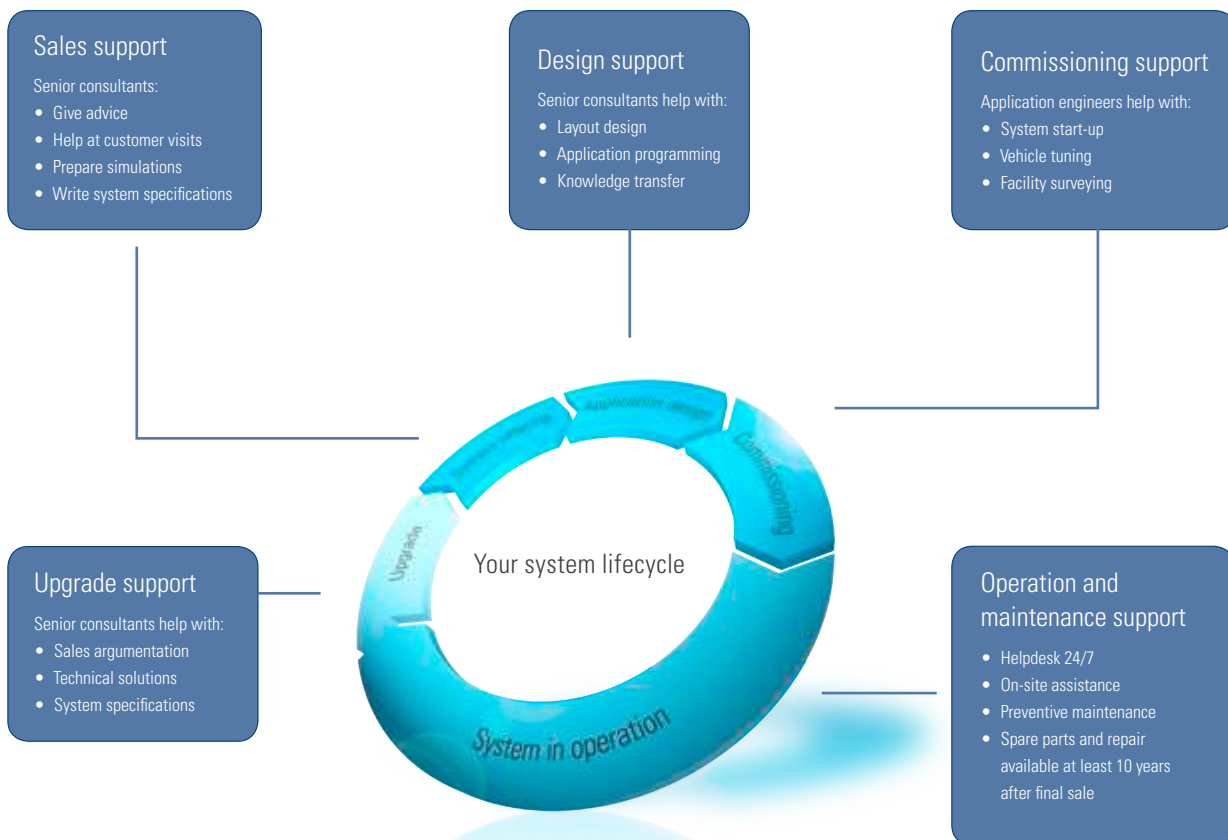

Model Nomenclature

AKD® Servo Drive

AKD – B 003 06 – NB AN – 0000

AKD Series

Version

B = Base drive

- C = Central power supply for AKD-N (Requires CB Extention)
- N = Decentralized drive (Requires DB, DF, or DS Extention)
- P = Position indexer (motion tasking)
- T = AKD BASIC Language Programmable drive (Requires IC or NB Extention)
- M = Multi-axis Master Drive (Requires MC Extention option, and EC Connectivity option)

Current Rating

- 003 = 3 Amp
- 006 = 6 Amp
- 010 = 10kW (With Version C, this field refers to power.)
- 012 = 12 Amp
- 024 = 24 Amp
- 048 = 48 Amp

Voltage

- 06 = 120/240 Vac 1Ø/3Ø (24 Amp Drive: 240 Vac 3Ø only)
- 07 = 240/480 Vac 3Ø (Version C: 07 = 400/480 Vac 3Ø | Version N: 07 = 560/680 Vdc)

Variants

0000 = Standard

Connectivity*

AN = Analog command

- CC = CANopen OR EtherCAT® P
- CN = CANopen P
- EC = EtherCAT® C, M, N, P
- EI = EtherNet/IP P
- PN - PROFINET P
- SQ = SynqNet B

Drive Version Availability

*Motion Tasking is included as a free upgrade with CC, CN, EC, EI and PN

Extension

- CB = without extention
- DB = hybrid motor cable
- DF = additional EtherCAT® port + feedback connector
- DS = local STO + feedback connector
- IC = Expanded I/O version and SD card slot ("T" version drive only)

NB = Without extensions

Note: Options shown in bold blue text are considered standard.

AKD® Servo Drive Cables

Feedback Cables

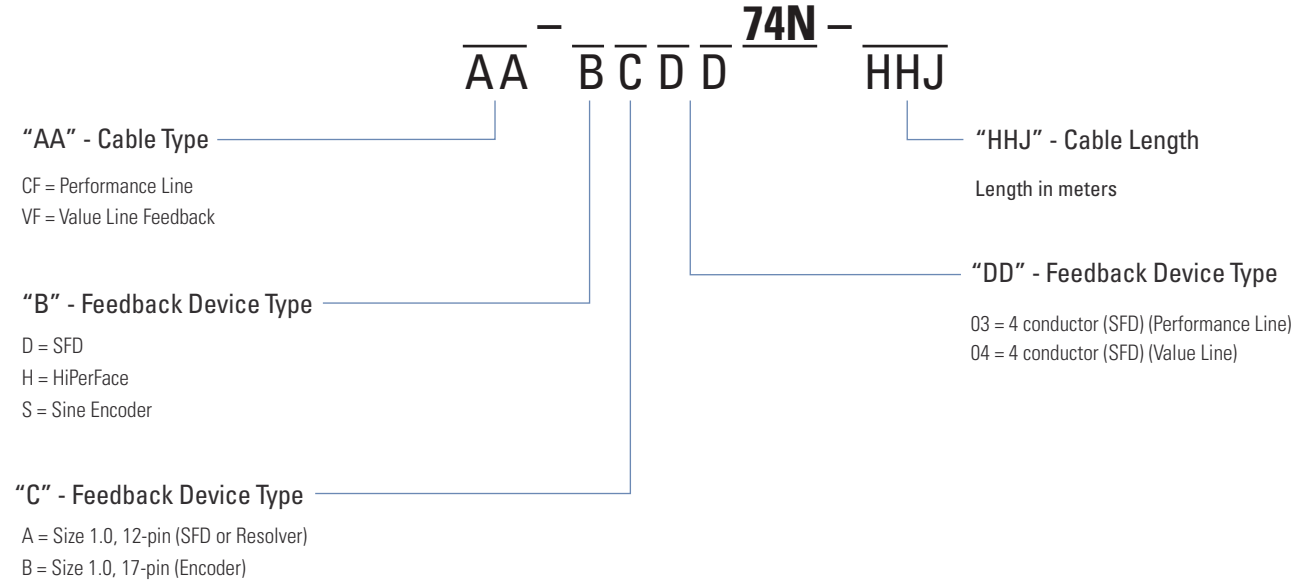

Power Cables

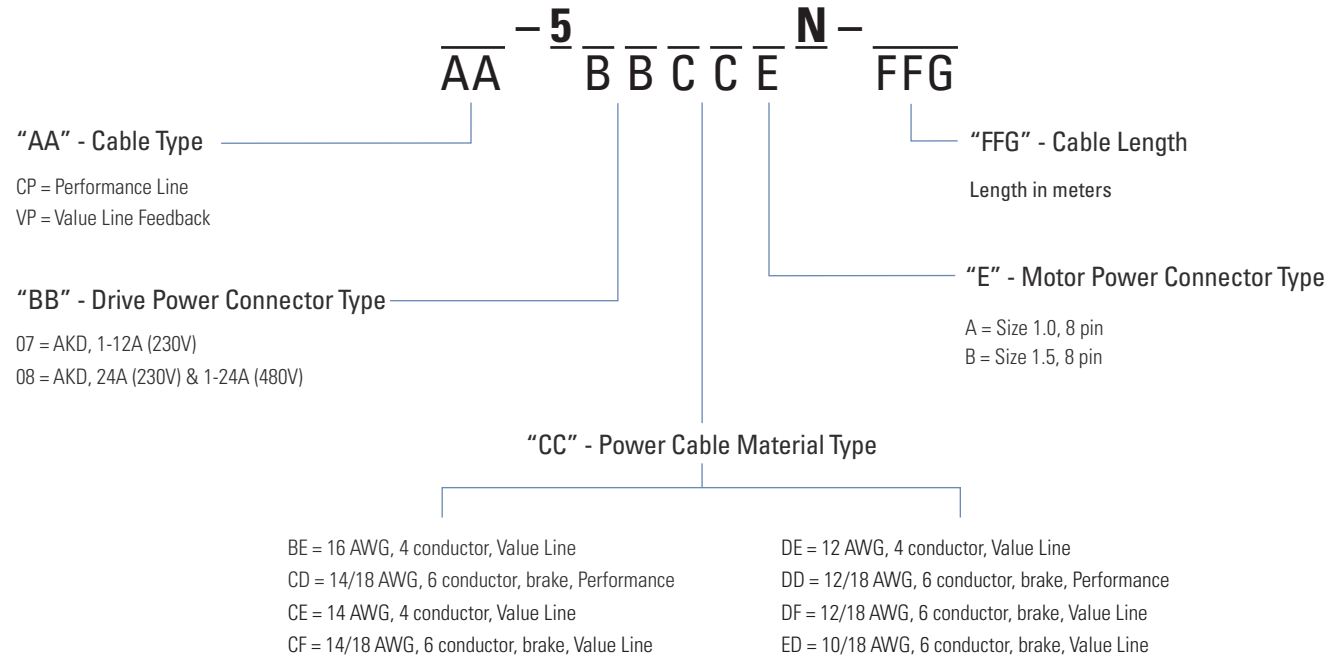

Model Nomenclature

AKM Brushless Servo Motor

AKM 6 2 P – A N C N DA 00

AKM Series

Flange Size

- 1 40 mm
- 2 58 mm
- 3 70 mm
- 4 84 mm
- 5 108 mm
- 6 138 mm
- 7 188 mm
- 8 260 mm

Rotor Length

- 1
- 2
- 3
- 4
- 5

Winding Type

- A to Z
- S Special

Flange

- A IEC with tolerance N**
- B NEMA
- C Alternative IEC standard
- D Other standard
- G Alternative IEC standard
- H Alternative IEC standard
- R IEC with tolerance R
- M, T Reinforced bearing AKM8
- W Flange coating for Washdown, IEC
- S Special

Version

- 00 Standard motor without shaft seal**
- 01 With shaft seal
- 0W Washdown
- 0F Washdown Food
- xx Special

Feedback Device

- For all options see opposite page
- S Special

Brake

- 2 24 V holding brake
- N Without brake**
- S Special

Connections

- For all options see opposite page
- S Special

Shaft

- C Keyway
- K Open keyway
- N Smooth shaft**
- S Special

Feedback Unit Options

Code	Designation	Model	Can be used with	Connection Option	Comment
1-	Comcorder		AKM1 - AKM8	1, 2, 7, B, C, G, H, T	1024 incr./rev
2-	Comcorder		AKM1 - AKM8	1, 2, 7, B, C, G, H, T	2048 incr./rev
AA	BiSS B encoder	AD36	AKM2 - AKM4	1, 7, B, C, M	Single-turn, optical
AA	BiSS B encoder	AD58	AKM5 - AKM8	1, 2, C, G, H, M, T	Single-turn, optical
AB	BiSS B encoder	AD36	AKM2 - AKM4	1,7,B, C, M	Multi-turn, optical
AB	BiSS B encoder	AD58	AKM5 - AKM8	1, 2, C, G, H, M, T	Multi-turn, optical
C-	Smart Feedback Device SFD	Size 10	AKM1	1, D, Y, M, P	Single-turn 4-wire
C-	Smart Feedback Device SFD	Size 15	AKM2 - AKM4	1, D, Y, M, P	Single-turn 4-wire
C-	Smart Feedback Device SFD	Size 21	AKM5 - AKM8	1, D, Y, M, P	Single-turn 4-wire
CA	Smart Feedback Device SFD3		AKM1 - AKM6	D	Single-turn 2-wire
DA	EnDAT 2.1 encoder	ECN 1113	AKM2 - AKM4	1, 7, B, C, M	Single-turn, optical
DA	EnDAT 2.1 encoder	ECN 1313	AKM5 - AKM8	1, 2, C, G, H, M, T	Single-turn, optical
DB	EnDAT 2.1 encoder	EQN 1125	AKM2 - AKM4	1, 7, B, C, M	Multi-turn, optical
DB	EnDAT 2.1 encoder	EQN 1325	AKM5 - AKM8	1, 2, C, G, H, M, T	Multi-turn, optical
LA	EnDAT 2.1 encoder	ECI 1118	AKM2 - AKM3	1, 7, B, C, M	Single-turn, inductive
LA	EnDAT 2.1 encoder	ECI 1319	AKM4 - AKM8	1, 2, C, G, H, M, T	Single-turn, inductive
LB	EnDAT 2.1 encoder	ECI 1130	AKM2 - AKM3	1,7, B, C, M	Multi-turn, inductive
LB	EnDAT 2.1 encoder	ECI 1331	AKM4 - AKM8	1, 2, C, G, H, M, T	Multi-turn, inductive
GJ	HIPERFACE encoder	SKS36	AKM2 - AKM8	1,2,7, B, C, G, H, M, T	Single-turn, optical
GK	HIPERFACE encoder	SKM36	AKM2 - AKM8	1,2,7, B, C, G, H, M, T	Multi-turn, optical
GP	HIPERFACE encoder	SEK34	AKM1	1, Y, M	Single-turn, capacitive
GR	HIPERFACE encoder	SEL34	AKM1	1, Y, M	Multi-turn, capacitive
GE	HIPERFACE DSL encoder	EKS36	AKM2 - AKM8	D	Single-turn, optical
GF	HIPERFACE DSL encoder	EKM36	AKM2 - AKM8	D	Multi-turn, optical
GM	Safety HIPERFACE	SKS36S	AKM2 - AKM8	1, 2, 7, B, C, G, H, M, T	Single-turn, optical
GN	Safety HIPERFACE	SKM36S	AKM2 - AKM8	1, 2, 7, B, C, G, H, M, T	Multi-turn, optical
MA	Drive Cliq	ECN1324S	AKM4 - AKM8		Single-turn, optical
MB	Drive Cliq	EQN1336S	AKM4 - AKM8	tba	Multi-turn, optical
R-	Resolvers	Size 10	AKM1	1,2,7, B, C, G, H, M, T, Y	2-pin, hollow shaft
R-	Resolvers	Size 15	AKM2 - AKM4	1,2,7, B, C, G, H, M, T, Y	2-pin, hollow shaft
R-	Resolvers	Size 21	AKM5 - AKM8	1,2,7, B, C, G, H, M, T, Y	2-pin, hollow shaft

* not available for AKM2 with connection option C (cable with IP65 connector)

Connector Options

Code		Can be used with	Protection class	Connection type	Description
With PTC	With KTY 84-130				
B	1	AKM2	IP65	2 threaded connectors, size 1.0	Angled, rotatable, mounted on motor
C	7	AKM1 - AKM2	IP65	2 threaded connectors, size 1.0	On 0.5 m cable
C	1	AKM3	IP65	2 threaded connectors, size 1.0	Angled, rotatable, mounted on motor
C	1	AKM4 - AKM7	IP65	2 Speed Tec Ready connectors, size 1.0	Angled, rotatable, mounted on motor
-	D	AKM1	IP65	1 hybrid i-tec connector	Mounted on motor
-	D	AKM2 - AKM6	IP65	1 hybrid threaded connector, size 1.0	Angled, rotatable, mounted on motor
G	-	AKM2 - AKM3	IP65	2 threaded connectors, size 1.0	Straight, mounted on motor
G	-	AKM4 - AKM6	IP65	2 Speed Tec Ready connectors, size 1.0	Straight, mounted on motor
H	1	AKM74Q and AKM82T	IP65	1 feedback threaded connector, size 1.0 1 power threaded connector, size 1.5	Angled, rotatable, mounted on motor
M	-	AKM1 - AKM4	IP20	2 Molex connectors, I ₀ < 6 A	On 0.5 m cable
P	-	AKM1 - AKM4	IP20	1 Molex connector, I ₀ < 6 A	On 0.5 m cable
R	-	AKM4 - AKM7	IP65	1 feedback threaded connector M12 1 power connector SpeedTec-Ready M23	Straight, mounted on motor Angled, mounted on motor
T	2	AKM8	IP65	1 terminal box IP65 for power 1 Feedback threaded connector, size 1.0	Mounted on motor
Y	1	AKM1	IP65	1 y-tec® connector	Mounted on motor

Model Nomenclature

AKMH Brushless Servo Motor

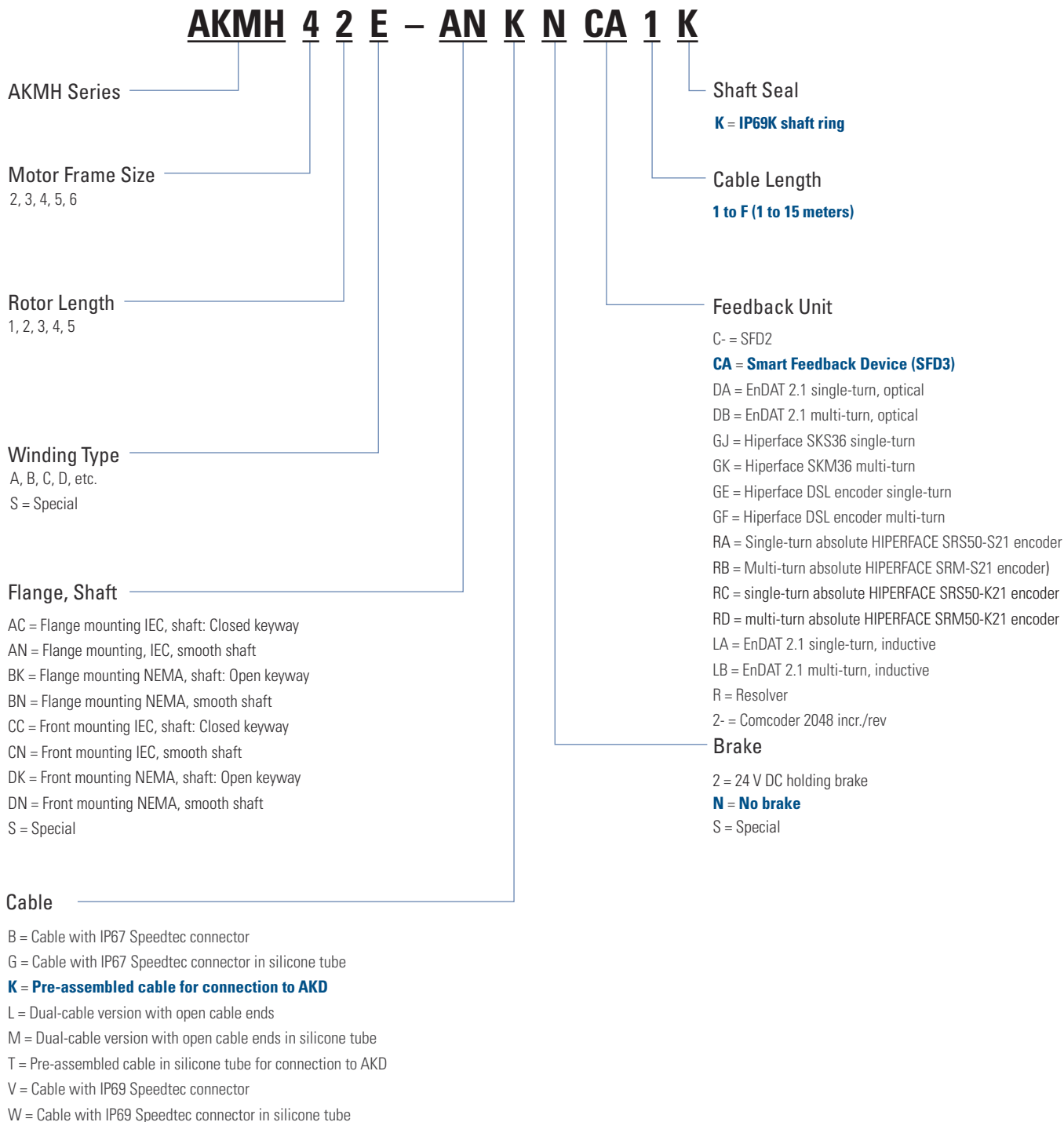

Cartridge DDR Motor

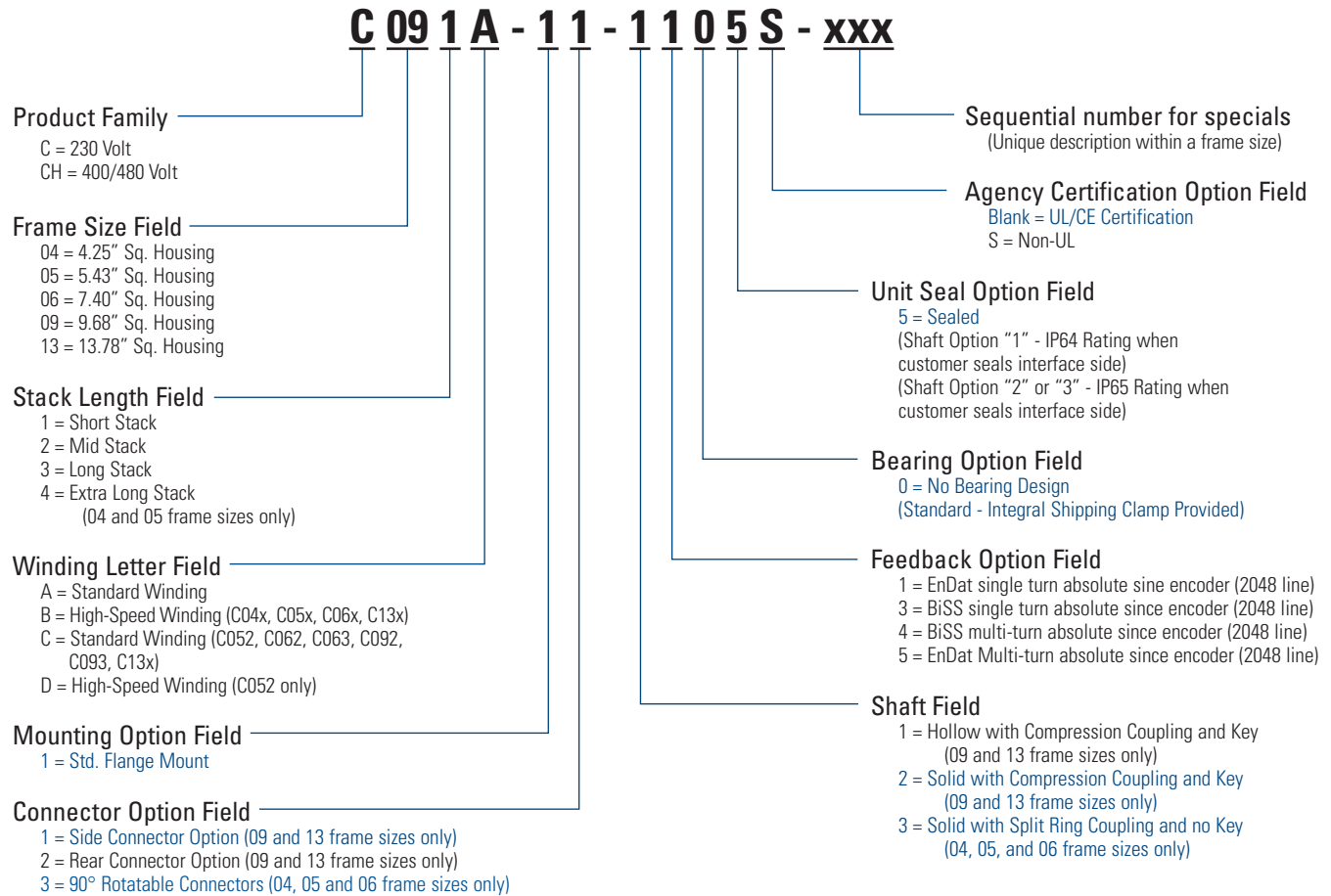

Note: Options shown in bold blue text are considered standard.

Model Nomenclature

MODEL NOMENCLATURE

Housed DDR Motor

DH 08 1 M - 1 2 - 1 3 1 0 - xxx

Direct Drive Series

D = 115/230 VAC winding
 DH = 400/480 VAC winding

Motor Frame Size

06 = 6.93" O.D.
 08 = 8.60" O.D.
 10 = 11.19" O.D.
 14 = 14.25" O.D.

Rotor Stack Length

1 = Short stack
 2 = Mid stack
 3 = Long stack

Winding Type

A = Std. w/ resolver¹
 M = Std. w/ sine encoder

Mounting Option

1 = Face mount
 2 = Flange mount

Designated for Specials

Unit Seal

0 = Non-sealed unit
 5 = IP65² - length increase
 7 = IP67² - length increase

Bearing Option

1 = Single bearing design
 2 = Dual bearing design³

Feedback Device

2 = Resolver ("A" Winding Type)¹
 3 = Sine Encoder ("M" Winding Type)

Shaft Option

1 = Straight thru bore w/ face coupling

Connector Type

2 = Straight
 3 = 90°, rotatable

Notes:

1. Not available on D14x & DH14x.
2. Encoder sealed motors have increased length. See outline drawing.
3. Standard on D143 & DH143 models.
4. Options shown in bold blue text are considered standard.

KBM Frameless Motor

KBM(S) - 25 H 01 - A XX

Product Family

KBM = Frameless motor
 KBMS = Frameless motor with sensors

Motor Frame Size (Armature I.D.)

10	57
14	60
17	79
25	88
35	118
43	163
45	260

Insulation Ratings

H = High voltage insulation (>240 Vac), S = Low-Voltage insulation (≤ 240 Vac)
 Note: H insulation is standard option for frame sizes 10, 14, 17, 25, 35 and 45.

Sequential Number for Available Modifications

Winding Options
 (A, B, C, etc...)

Stack Length Specifier
 00 = 0
 01 = 1
 02 = 2
 03 = 3
 04 = 4
 05 = 5

TBM Frameless Motor

TBM(S) - 6013 - A 00

Product Family

TBM = Frameless motor
 TBMS = Frameless motor with Hall sensors

Motor Frame Size (Armature Outer Diameter)

60
76
129

Sequential Number for Available Modifications

Winding Options
 A, B

Stack Length Specifier

Model Nomenclature

MODEL NOMENCLATURE

P-Series Stepper Drive

P7 03 6 0 – SD N

P-Series

- P5 = P5000 Series
- P6 = P6000 Series
- P7 = P7000 Series

Current Rating

- 03 = 2.5 Arms continuous, 3.5 Arms peak (AC models only)
- 05 = 5 Arms continuous, 7.2 Arms peak (DC models only)
- 06 = 5.7 Arms Continuous, 8.0 Arms peak*

Voltage Range

- 3 = 20 - 75 Vdc
- 6 = 120/240 Vac (160/320 Vdc)

Electrical Options

0 = None

Customization

- Omit field for standard configurations
- 000 = Optimized for Standard POWERPAC
- 001 = Optimized for Enhanced POWERPAC
- PMX = Optimized Powermax Settings

Feedback Device

- N = No feedback, with mating connectors (P6000)**
- 0 = No feedback, no connectors

Functionality

- PN = Motion node indexing
- SD = Step/direction base drive, Internal VCO (P5000)**
- R4 = RS485 (P70360 only)

PMX™ Series Stepper Motor

PMX 11 2 0 - A 1 0 - B N 0 - 00

Motor Series

NEMA Motor Frame Size

08, 11, 14, 17, 23, 34

Rotor Stack Length

1 = 1 stack All PMX series motors
 2 = 2 stacks All PMX series motors
 3 = 3 stacks PMX11, -17, -23, -34
 4 = 4 stacks PMX17, -23, -34
 5 = 5 stacks PMX17

Motor Winding

A, B, C, D Bipolar windings
 G, H, J Unipolar/Bipolar Series windings

Step Angle

1 = 1.8° All PMX series motors
 9 = 0.9° PMX17, PMX23

Sealing Option

00 = No shaft seal All PMX
 01 = Shaft seal PMX23, PMX34
 XX = Special motor designator All PMX

Rear Shaft Option

0 = No rear shaft All PMX series motors
 R = Rear shaft All PMX series motors

Front Shaft Option

N = Normal/Smooth front shaft All PMX
 F = Flat front shaft All PMX
 K = Open keyway PMX34

Connection/Hookup Option

B = 4 lead Bipolar All PMX
 U = 6 lead Unipolar PMX17, -23
 X = Integrated Connector PMX17, -23

Model Nomenclature

MODEL NOMENCLATURE

E & H Series Stepper Motor

E 3 3 H C H P - L E K - M2 - 01

Basic series

H = Standard construction

E = SIGMAX construction (n/a half stack)

Size

2 = NEMA 23

frame size (2.25" dia.)

3 = NEMA 34

frame size (3.38" dia.)

4 = NEMA 42

frame size (4.28" dia.)

Number of Rotor Stacks

H = Half stack (H series only)

1 = 1 stack

2 = 2 stacks

3 = 3 stacks (size 3,4 only)

4 = 4 stacks (size 3 only)

Mounting

N = NEMA (n/a 4 stacks)

H = Heavy duty NEMA

(opt. on 3 stacks, std. on 4 stacks)

S = Special, contact customer support

Construction/Connection Style

R = Regular/leadwire

C = System MS connector

L = Splashproof/to terminal board via conduit connector: 1/2" NPS pipe thread (size 3,4 only)

M = Splashproof/to terminal board via conduit connect: metric PG11 pipe thread (size 3,4 only)

S = Special, contact customer support

Number of Connections

F = 8 lead

L = 4 lead series

H = 4 lead parallel

E = 6 lead

Winding Type

T = Max. torque at low speed

P = Max. torque torque at high speed

A, B and C = Additional standards

S = Special, contact customer support

Special Sequence

00 = Standard motor without shaft seal

01 = Standard motor with shaft seal (size 3 and 4 only)

Other numbers will be assigned for special motors

Encoder Option

NS = No feedback

All options below require construction R or C

M1 = Encoder mounting provision (size 2 only). Requires shaft configuration E

HD = 500 LPR encoder (size 2 only)

HJ = 512 LPR encoder (size 2 only)

M2 = HP encoder mounting provision (size 3,4 only). Requires shaft configuration E

M3 = BEI encoder mounting provision (size 3,4 only). Requires shaft configuration D

SS = Special, contact customer support

Shaft Modifications

N = Smooth (size 2,3 only)

(mounting config. N only)

F = Flat (size 2,3 only)

(mounting config. N only)

K = Straight key (size 3,4 only)

(mounting config. H only)

W = #303 Woodruff key (size 3 only)

(mounting config. N only)

S = Special

Shaft Configuration (Diameter & Length)

N = Single

D = Double (R or C construction only)

E = Double ended for encoder (R or C construction only, size 3,4 only)

S = Special, contact customer support

Rotor Type

L = Laminated

J = Low inertia (size 2 only, n/a with half stack motors)

Note: Options shown in bold blue text are considered standard.

NEMA 34 K & N Series Stepper Motor

N 3 3 H C H J - L E K - M2 - 01

K and N series
N = Standard construction
 K = Sigmax construction

Size
 3 = NEMA 34 frame size;
 3.38" width/height, square frame

Length
 1 = 1 stack
 2 = 2 stacks
 3 = 3 stacks
 4 = 4 stacks

Mounting
H = Heavy duty NEMA
 S = Special, contact customer support

Construction/Connection Style
R = Regular/leadwire
 C = System MS connector
 L = splashproof/to terminal board via conduit connector: 1/2" NPSC pipe thread
 M = Splashproof/to terminal board via conduit connect: metric PG11 pipe thread
 S = Special, contact customer support

Number of Connections
F = 8 lead (n/a C construction)
 L = 4 lead series
 H = 4 lead parallel
 E = 6 lead (n/a C construction)

Special Sequence
00 = Standard motor without shaft seal
 01 = Standard motor with shaft seal
 Other numbers will be assigned for special motors

Encoder Option
NS = No feedback
 M2 = Encoder mounting provision (must use construction C or R and shaft configuration E)
 PD = 500 LPR encoder
 PF = 1000 LPR encoder
 SS = Special, contact customer support

Shaft Modifications
K = Straight key
 S = Special, contact customer support

Shaft Configuration (Diameter & Length)
N = Single
 D = Double (R or C construction only)
 E = Double ended for encoder (R or C construction only)

Rotor Type
L = Laminated

Winding Type
 H = Standard, 1 stack only
 D, E, G, J, K, L = Standard
 M = Standard, N/A on 1 stack
 S = Special, contact customer support

Note: Options shown in bold blue text are considered standard.

Model Nomenclature

MODEL NOMENCLATURE

NEMA 42 K & N Series Stepper Motor

N 4 3 H C H J - L E K - M2 - 01

K and N series

N = Standard construction

K = Sigmax construction

Size

4 = NEMA 42 frame size;
 4.325" width/height, square frame

Length

1 = 1 stack
 2 = 2 stacks
 3 = 3 stacks

Mounting

H = Heavy duty NEMA

S = Special, contact customer support

Construction/Connection Style

R = Regular/leadwire

C = System MS connector

L = splashproof/to terminal board via conduit
 connector: 1/2" NPSC pipe thread

M = Splashproof/to terminal board via
 conduit connect: metric PG13.5 pipe thread

S = Special, contact customer support

Number of Connections

F = 8 lead (n/a C construction)

L = 4 lead series

H = 4 lead parallel

E = 6 lead (n/a C construction)

Special Sequence

00 = Standard motor without shaft seal

01 = Standard motor with shaft seal
 Other numbers will be assigned for special motors

Encoder Option

NS = No feedback

M2 = Encoder mounting provision
 (must use construction C or R and shaft configuration E)

PD = 500 LPR encoder

PF = 1000 LPR encoder

SS = Special, contact customer support

Shaft Modifications

K = Straight key

S = Special, contact customer support

Shaft Configuration
 (Diameter & Length)

N = Single

D = Double (R or C construction only)

E = Double ended for encoder
 (R or C construction only)

S = Special, contact customer support

Rotor Type

L = Laminated

Winding Type

J = Standard, 1 stack only

K, N = Standard, N/A on 1 stack

L = N/A on 1 stack

F, M, G = Standard

S = Special, contact customer support

Note: Options shown in bold blue text are considered standard.

M & P Series Stepper Motor

P 2 1 N R X A - L N N - N S - 00

Series

P = Standard

M = Enhanced (n/a half stack)

Size

2 = NEMA 23

(2.25" across flat)

Number of Stacks

H = Half stack

1 = 1 stack

2 = 2 stacks

Mounting

N = NEMA

S = Special, contact customer support

Construction

R = Regular

S = Special, contact customer support

Termination

X = Receptacle

F = 8 flying leads

S = Special, contact customer support

For X (receptacle) designation, Mating leaded connectors may be ordered separately. Optional GRN/YEL ground wire available.

Winding Type

A, B, C, D

S = Special, contact customer support

Sequence Number

Insert 00 if all parts are standard.

Other numbers will be assigned for special motors.

Encoder Option

NS = No Feedback

Use encoders below. You must specify shaft configuration D (double ended)

Caution: An encoder with line driver output may be required for use with some stepper motor controls.

M1 = Encoder mounting provisions

HD = Encoder 500 LPR

HJ = Encoder 512 LPR

SS = Special, contact customer support

Shaft Modifications

N = Smooth

F = Flat

S = Special, contact customer support

Shaft Configuration (Diameter & Length)

N = Single

D = Double

S = Special, contact customer support

Rotor Type

L = Standard

J = Low inertia (n/a half stack)

Note: Options shown in bold blue text are considered standard.

Model Nomenclature

MODEL NOMENCLATURE

MH172 Stepper Motor

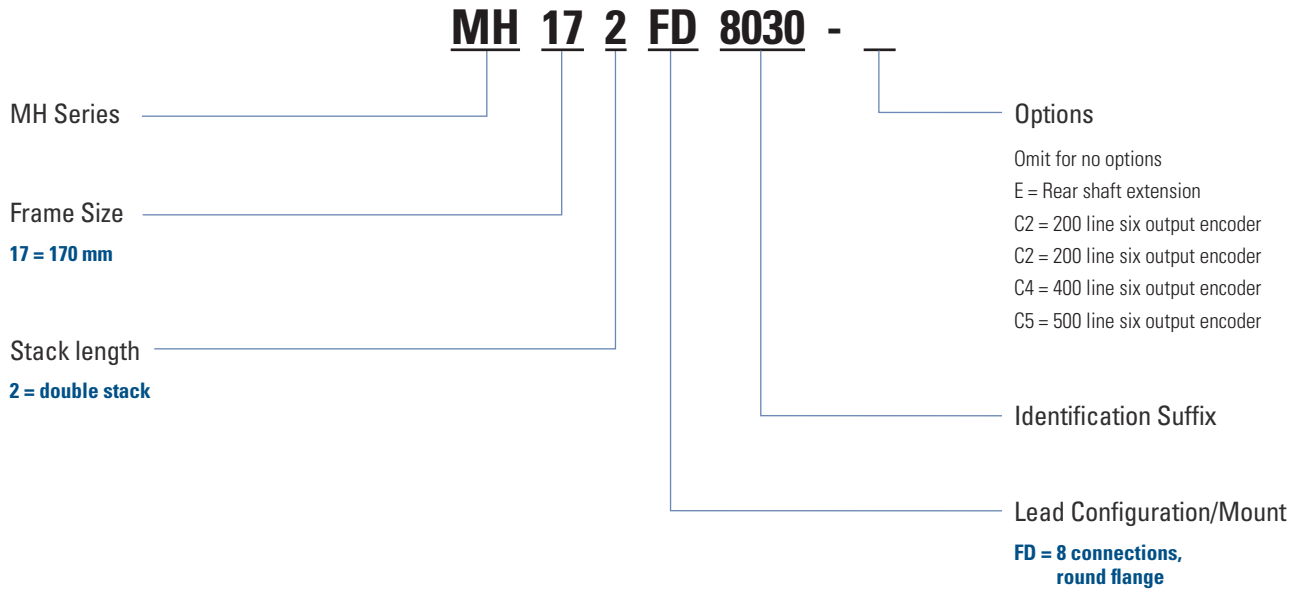

MX Series Hazardous Duty Stepper Motor

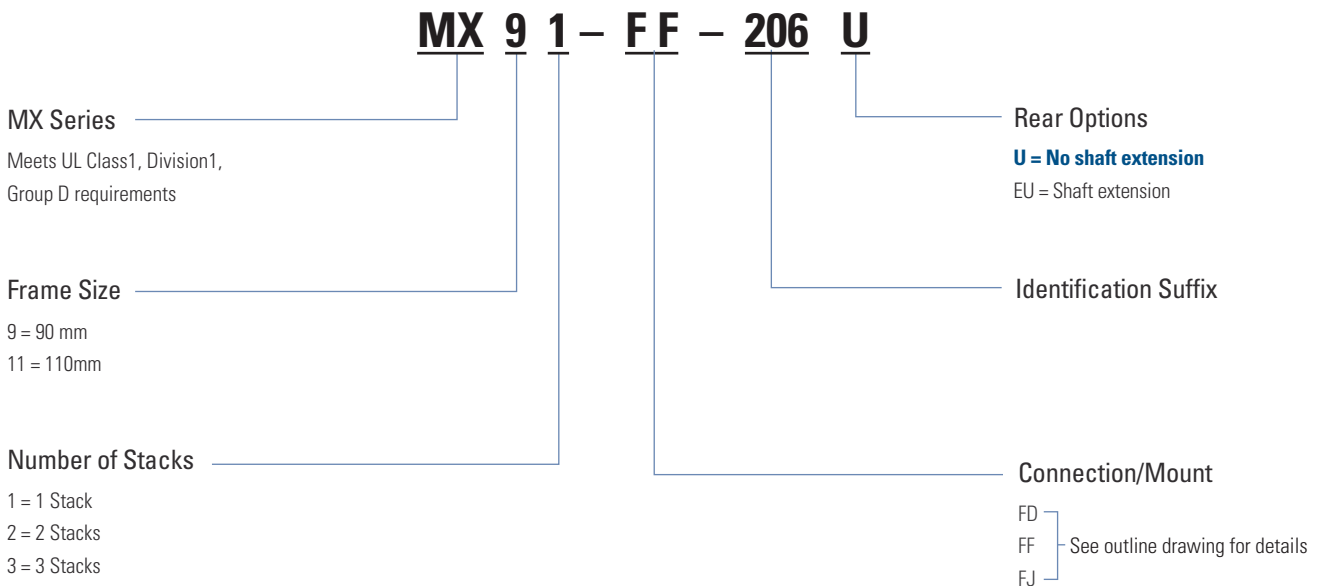

Note: Options shown in bold blue text are considered standard.

T2 Series Stepper Motor

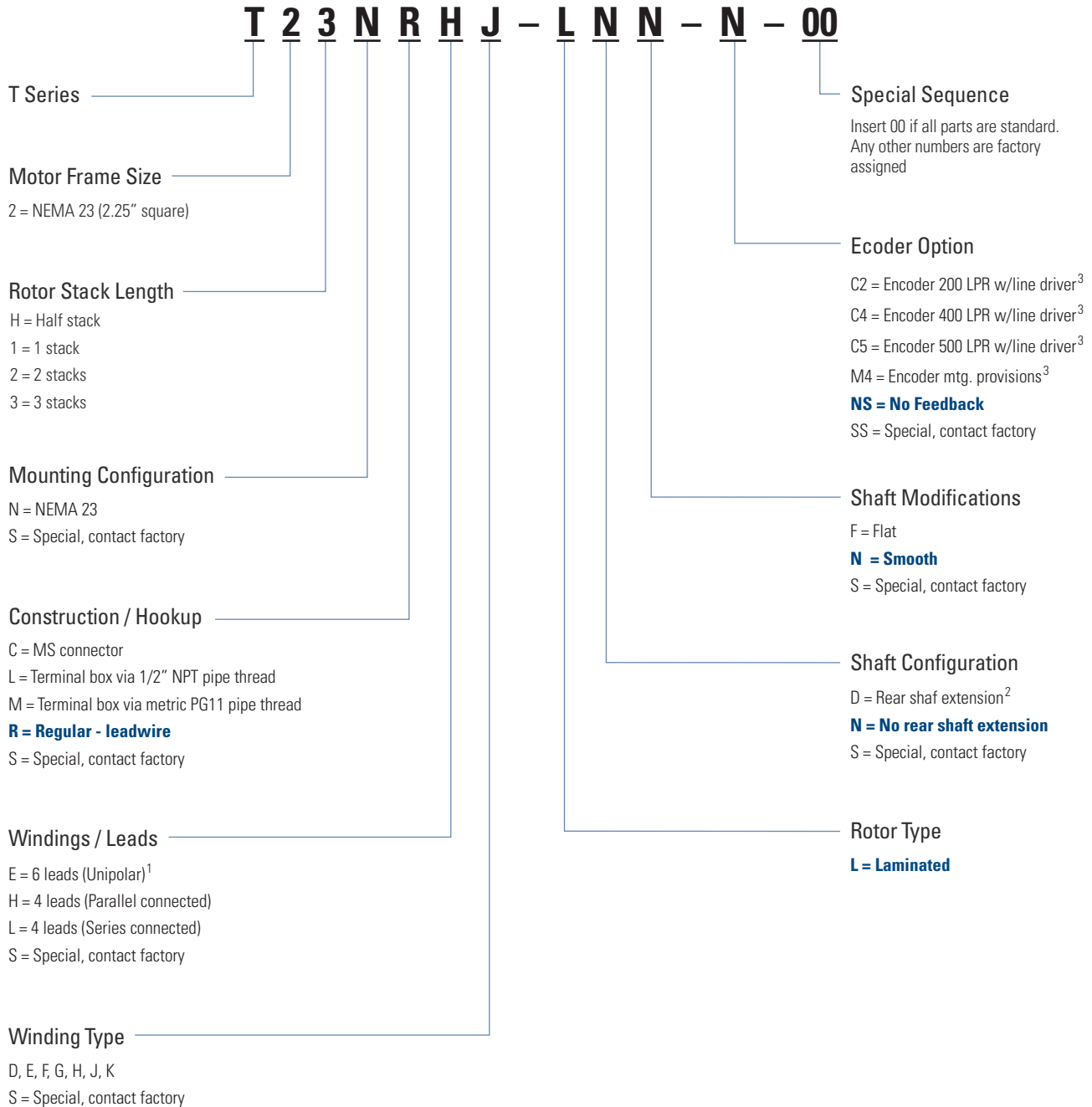

Notes:

1. N/A with "C" Construction / Hookup option
2. "R" Construction / Hookup only, required for motors with encoders
3. Requires "R" Construction / Hookup option and "D" Shaft Configuration option

Model Nomenclature

MODEL NOMENCLATURE

KS Series AC Synchronous Motor

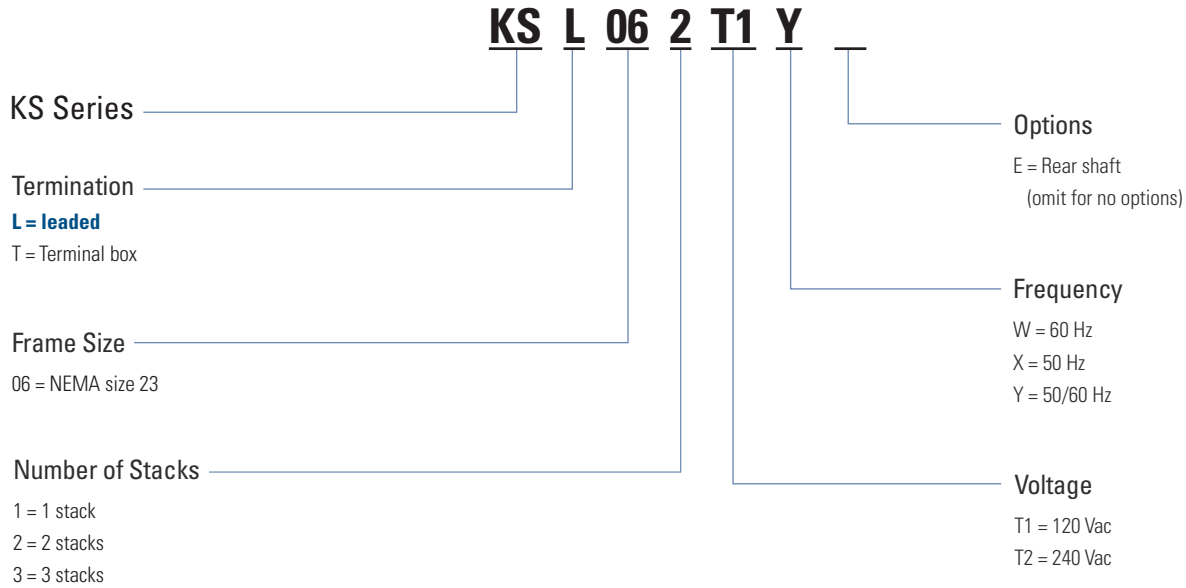

X(CE) Series AC Synchronous Motor

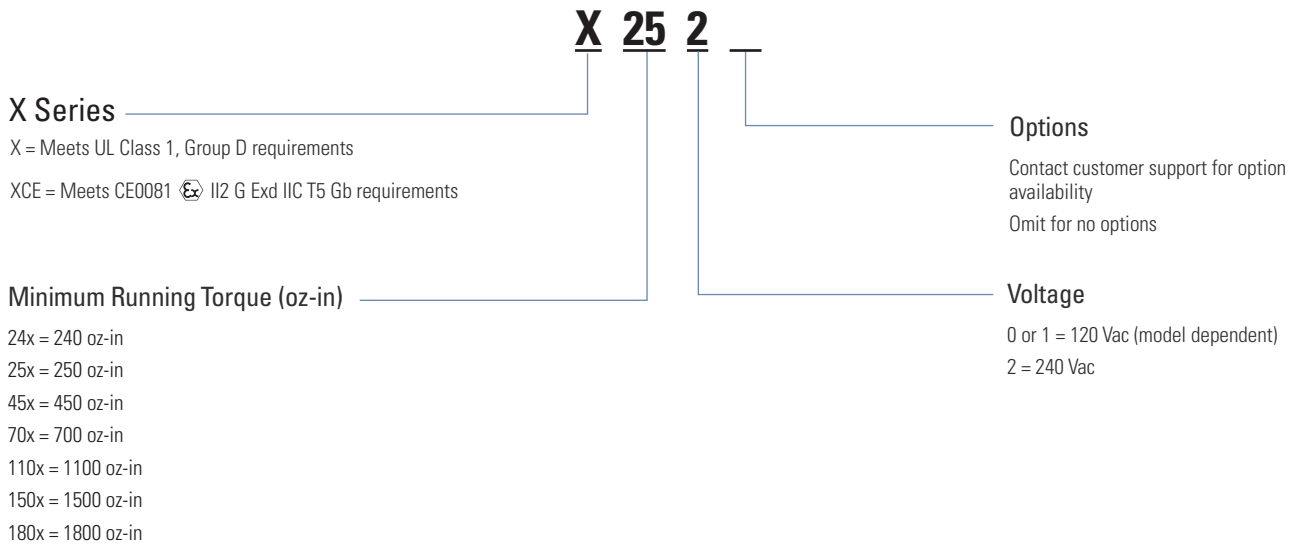

Note: Options shown in bold blue text are considered standard.

SS Series AC Synchronous Motor

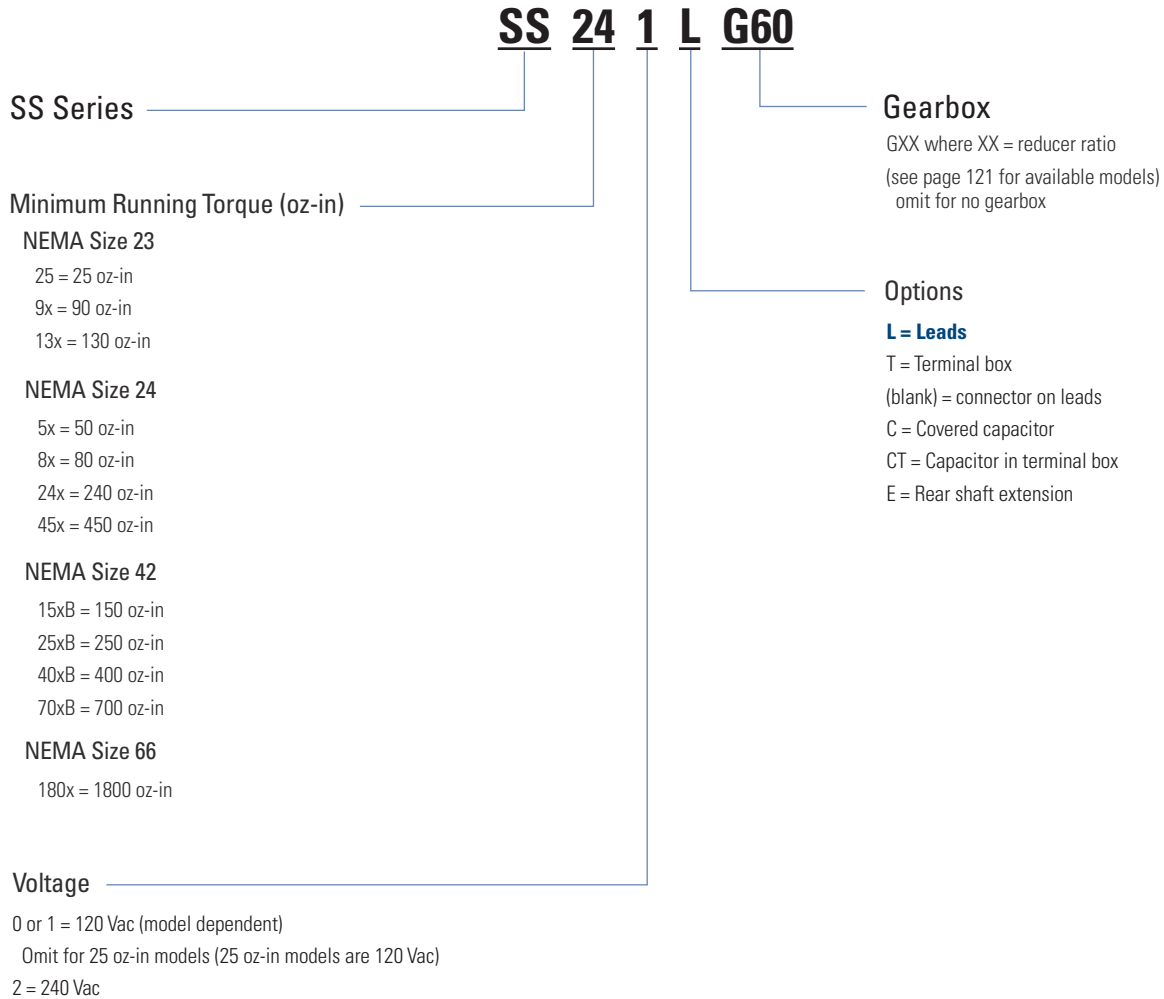

Note: Options shown in bold blue text are considered standard.

Model Nomenclature

MODEL NOMENCLATURE

Micron™ TRUE Planetary™ Gearbox

DTR 115 - 005 - 0 - ()

Gearbox Series

- AT = AquaTRUE™
- NT = NemaTRUE™
- NTP = NemaTRUE PLUS™
- NTR = NemaTRUE 90™
- XT = XTRUE™
- ET = EverTRUE™
- DT = DuraTRUE™
- DTR = DuraTRUE 90™
- DTRS = DuraTRUE™ slimline
- DTRH = DuraTRUE™ hollow shaft
- DTRD = DuraTRUE™ dual shaft
- VT = ValueTRUE™
- VTR = ValueTRUE 90™
- UT = UltraTRUE™
- UTR = UltraTRUE 90™

Motor Model Number

RediMount number (if available)
 or motor manufacturer and model number

Customer Options

- 0 = None
- S = Special
- H = High precision
 (for NemaTRUE™ product line only)

Gearbox Ratio

See ratio availability in corresponding
 gearbox section (pp 51-53)

Gearbox Size

AquaTRUE™
 060 = Size 60
 080 = Size 80
 120 = Size 120
 160 = Size 160

NemaTRUE™
NemaTRUE PLUS™
NemaTRUE 90™
 17 = Size 17
 23 = Size 23
 34 = Size 34
 42 = Size 42
 60 = Size 60
 90 = Size 90
 115 = Size 115

XTRUE™
 040 = Size 40
 060 = Size 60
 080 = Size 80
 120 = Size 120
 160 = Size 160

EverTRUE™
 10 = Size 10
 14 = Size 14
 18 = Size 18

DuraTRUE™
DuraTRUE 90™
DuraTRUE™ Slimline
DuraTRUE™ Hollow Shaft
DuraTRUE™ Dual Shaft
 60 = Size 60
 90 = Size 90
 115 = Size 115
 142 = Size 142

ValueTRUE™
ValueTRUE 90™
 006 = Size 60
 075 = Size 75
 090 = Size 90
 010 = Size 10
 115 = Size 115
 014 = Size 14
 018 = Size 18
 022 = Size 22

UltraTRUE™
UltraTRUE 90™
 006 = Size 60
 075 = Size 75
 090 = Size 90
 010 = Size 10
 115 = Size 115
 014 = Size 14
 018 = Size 18
 022 = Size 22 (UltraTRUE™ only)

EC Series Electric Cylinder with AKM Servo Motors

EC Series **Motor Type** **Motor Options** **Drive Ratio** **Screw Lead** **Stroke Length** **Cylinder Mounting** **Rod Ends** **Options** **Cable Option**
EC2 – **AKM23D** – **BNC** – **10** – **05B** – **300** – **MP2** – **FT1M** – **()** – **CO**

EC Series

EC1
 EC2
 EC3
 EC4
 EC5

Motor Type

AKM11B = AKM11B-ANCNx-00 brushless servo
 AKM13C = AKM13C-ANCNx-00 brushless servo
 AKM23D = AKM23D-EFxxx-00 brushless servo
 AKM23C = AKM23C-EFxxx-00 brushless servo
 AKM42G = AKM42G-EKxxx-00 brushless servo
 AKM42E = AKM42E-EKxxx-00 brushless servo
 AKM52G = AKM52G-EKxxx-00 brushless servo
 AKM52H = AKM52H-EKxxx-00 brushless servo
 AKM52L = AKM52L-EKxxx-00 brushless servo
 X = Customer-supplied motor
 (motor described in Options element of part number)

Motor Options

B ■■ = Rotatable IP65 connectors
C ■■ = 0.5 m shielded cables w/ IP65 connectors
C ■■ = Rotatable IP65 connectors
■ N = No brake
■ 2 = 24 Vdc power-off holding brake
■ R = Resolver
■ 2 = 2048 LPR incremental comm. encoder
■ C = Smart Feedback Device (SFD)

Drive Ratio

10 = 1.0:1 drive belt/pulley (EC1 – helical)
 10L = 1.0:1 inline coupling (direct 1:1 coupling is the only ratio available for inline models)
 15 = 1.5:1 drive belt/pulley
 20 = 2.0:1 drive belt/pulley (EC1 – helical)
 40 = 4.0:1 helical gears
 50 = 5.0:1 helical gears
 70 = 7.1:1 helical gears
 100 = 10.0:1 helical gears

Screw Lead

03M = 3 mm/rev ballscrew
 05B = 5 mm/rev ballscrew
 10B = 10 mm/rev ballscrew
 16B = 16 mm/rev ballscrew
 25B = 25 mm/rev ballscrew
 32B = 32 mm/rev ballscrew
 04A = 4 mm/rev lead screw

Available

EC1
 EC1
 EC2, EC3
 EC2, EC3
 EC3, EC4, EC5
 EC3, EC4, EC5
 EC4, EC5
 EC4, EC5
 EC4, EC5
 All

Available

AKM2
 AKM1, AKM2
 AKM4, AKM5
 AKM1, AKM2, AKM4, AKM5
 AKM2, AKM4, AKM5
 AKM1, AKM2, AKM4, AKM5
 AKM1, AKM2, AKM4, AKM5
 AKM1, AKM2, AKM4, AKM5

Available

All
 All
 EC2, EC3, EC4, EC5
 Not valid for EC3-AKM42
 EC1 only
 EC2, EC3, EC4, EC5
 EC3 only
 EC2, EC4, EC5

Available

EC1
 EC2, EC3
 EC3, EC4, EC5
 EC2, EC3
 EC4
 EC5
 EC2, EC3

Stroke Length

50 = 50 mm total stroke
 100 = 100 mm total stroke
 150 = 150 mm total stroke
 200 = 200 mm total stroke
 250 = 250 mm total stroke
 300 = 300 mm total stroke
 450 = 450 mm total stroke
 600 = 600 mm total stroke
 750 = 700 mm total stroke
 1000 = 1,000 mm total stroke
 1250 = 1,250 mm total stroke
 1500 = 1,500 mm total stroke
 nnn = Custom stroke lengths available in 10 mm increments

Cylinder Mounting

MF1 = Front rectangular flange
 MF1E = Front rectangular flange (English)
 MF1M = Front rectangular flange (metric)
 MF2 = Rear rectangular flange
 MF2E = Rear rectangular flange (English)
 MF2M = Rear rectangular flange (metric)
 MF3 = Front & rear rectangular flange
 MF3E = Front & rear rectangular flange (English)
 MF3M = Front & rear rectangular flange (metric)
 MP2 = Rear double clevis without pivot base
 MP3 = Rear double clevis with pivot base
 MS1 = Side end angle
 MS2 = Side lugs
MS6M = Side tapped holes (metric)
 MS6E = Side tapped holes (English)
 MT4 = Trunnion

Rod Ends

FC2 = Clevis (includes MT1M)
 FS2 = Spherical joint (includes FT1M)
 FT1M = Female thread (metric)
 FT1E = Female thread (English)
MT1M = Male thread (metric)
 MT1E = Male thread (English)

Options

(add multiple in the following sequence, omit if no options)

BA24 = 24 Vdc brake on actuator (EC1 only, not available with 10L ratio or MS1 mounting options)
 BS24 = 24 Vdc brake on ballscrew (not available with EC1 or 10L ratio, or with MF2(x), MF3(x), MS1, MP2(x), MP3(x) mounting options)
 BS115 = 115 Vac brake on ballscrew (not available with EC1 or 10L ratio, or with MF2(x), MF3(x), MS1, MP2(x), MP3(x) mounting options)
 PB = Protective boot*
 L = Linear potentiometer (only valid through 600 mm stroke, standard lengths)*
 17X = NEMA 17 mountless motor (EC1 only)

Cable

CO = No cable supplies, motor includes connectors.
Default for all AKM Servo Motors; select cable as an accessory.

*Contact customer service for EC1

Available

All
 All
 All
 All
 EC2, EC3, EC4, EC5
 EC2, EC3, EC4, EC5
 EC2, EC3, EC4, EC5
 EC2, EC3, EC4, EC5
 EC2, EC3, EC4, EC5
 EC3, EC4, EC5
 EC4, EC5
 EC4, EC5

Available

EC1, EC2, EC3, EC5
 EC4 only
 EC4 only
 EC2, EC3, EC5
 EC4 only
 EC4 only
 EC2, EC3, EC5
 EC4 only
 EC4 only
 All
 All
 EC2, EC3
 All
All
 EC2, EC3, EC4, EC5
 EC2, EC3, EC4, EC5

Available

All
 All
 All
 EC2, EC3, EC4, EC5
All
 EC2, EC3, EC4, EC5

Note: Options shown in bold blue text are considered standard.

Model Nomenclature

N2 Series Electric Cylinder with AKM Servo Motors

N2 – AKM23D – BNC – 15 – 5B – 8 – MP2 – FT1M – () – CO

N2 Series

Motor Type*

AKM23D = AKM23D-EFxxx-00 brushless servo
 AKM23C = AKM23C-EFxxx-00 brushless servo

Motor Options

- B ■ ■** = Rotatable IP65 connectors
- C ■ ■ ■** = 0.5 m shielded cables w/ IP65 connectors
- N ■** = No brake
- 2 ■** = 24 Vdc power-off holding brake
- ■ R** = Resolver
- ■ 2** = 2048 LPR incremental comm. encoder
- ■ C** = Smart Feedback Device (SFD)

Drive Ratio

- 10 = 1.0:1 drive belt/pulley
- 10L = 1.0:1 inline coupling (direct 1:1 coupling is the only ratio available for inline models)
- 15 = 1.5:1 drive belt/pulley
- 20 = 2.0:1 drive belt/pulley
- 25 = 2.5:1 helical gears

Screw Pitch, Type

- 2B = 2 rev/inch ballscrew
- 5B = 5 rev/inch ballscrew
- 5A = 5 rev/inch lead screw
- 8A = 8 rev/inch lead screw

Stroke Length**

- 2 = 2 inch total stroke
- 4 = 4 inch total stroke
- 6 = 6 inch total stroke
- 8 = 8 inch total stroke
- 12 = 12 inch total stroke
- 18 = 18 inch total stroke (requires -DB option, effective stroke is 16.5")
- 24 = 24 inch total stroke (requires -DB option, effective stroke is 22.5")
- nn.n = Custom stroke lengths available in 0.1 inch increments

Cable

CO = No cable supplied, motor includes connectors. Default for all AKM servo motors; select Kollmorgen cables based on motor/drive pairings.

Options***

(add multiple in the following sequence, omit if no option required)

- BS24 = 24 Vdc brake on lead screw (not available with 10L ratio, or with MF2, MF3, MS2, MP2, MP3 mounting options)
- DB = Dual rod end bearing
- PB = Protective boot
- W = Water resistant
- F = Sub-freezing temperature
- H = High temperature prep
- L = Linear potentiometer (only for valid std. lengths)

Rod Ends

FC2 = Clevis (includes MT1M)

- FE2 = Female eye rod end
- FS2 = Spherical joint (includes FT1M)
- FT1M = Female thread (metric)
- FT1E = Female thread (English)
- MT1M = Male thread (metric)
- MT1E = Male thread (English)

Cylinder Mounting

MF1 = Front rectangular flange

- MF2 = Rear rectangular flange
- MF3 = Front & rear rectangular flange
- MP2 = Rear double clevis without pivot base
- MP3 = Rear double clevis with pivot base
- MS1 = Side end angle
- MS2 = Side lugs
- MS6M = Side tapped holes (metric)
- MS6E = Side tapped holes (English)
- MT4 = Trunion

* Contact customer support for AKM combinations outside of those listed.
 ** For custom lengths round up to next standard incremental plus add standard cut fee.
 *** Contact customer support for non-standard pricing and lead times.
 Note: Options shown in bold blue text are considered standard.

MODEL NOMENCLATURE

Rodless Actuators R-Series with AKM Servo Motors

R Series	Motor Type*	Motor Options	Drive Ratio	Linear Drive Type	Stroke Length	Motor Orientation	Mounting Style	Carriage	English/ Metric	Cable Option					
R3	AKM42G	CNC	10	5B	12	P	A	S	E	CO					
R Series R2A, R3, R4	Motor Type* AKM23C = AKM23C-EFxxx-00 brushless servo AKM23D = AKM23D-EFxxx-00 brushless servo AKM42E = AKM42E-EKxxx-00 brushless servo AKM42G = AKM42G-EKxxx-00 brushless servo AKM52G = AKM52G-EKxxx-00 brushless servo AKM52H = AKM52H-EKxxx-00 brushless servo	Available R2A, R3 R2A, R3 R3, R4 R3, R4 R4 R4	Available 10 = 1.0:1 drive belt/pulley 15 = 1.5:1 drive belt/pulley 20 = 2.0:1 drive belt/pulley 30 = 3.0:1 drive belt/pulley 50 = 5:1 helical gear 70 = 7:1 helical gear 100 = 10:1 helical gear	Available 5A = 5 pitch (0.2" lead) lead screw 8A = 8 pitch (0.125" lead) lead screw 1B = 1 pitch (1" lead) ball screw 2B = 2 pitch (0.5" lead) ball screw 4B = 4 pitch (0.25" lead) ball screw 5B = 5 pitch (0.2" lead) ball screw T = Tangential drive belt	Available 6 = 6" of total stroke 12 = 12" of total stroke 18 = 18" of total stroke 24 = 24" of total stroke 30 = 30" of total stroke 36 = 36" of total stroke 42 = 42" of total stroke 48 = 48" of total stroke 54 = 54" of total stroke 60 = 60" of total stroke 66 = 66" of total stroke 72 = 72" of total stroke 84 = 84" of total stroke 96 = 96" of total stroke 108 = 108" of total stroke Custom lengths available in the increment of 1"	Options*** BS24 = 24 Vdc brake on lead screw (Screw option only, n/a with inline models, MF3 or "C" options) BS115 = 115 Vdc brake on lead screw (Screw option only, n/a with inline models, MF3 or "C" options) BS230 = 230 Vdc brake on lead screw (Screw option only, n/a with inline models, MF3 or "C" options) WR = Water resistant seal option right WL = Water resistant seal option left GR = Lube port, right side GL = Lube port, left side DC1 = Idler carriage between driven carriage and non-motor end DC2 = Idler carriage between driven carriage and motor end VR = Breather vent, fitting, tubing, right side VL = Breather vent, fitting, tubing, left side CO = No motor cable S = Stub shaft	Available R2A, R3, R4 R2A, R3, R4 R2A, R3, R4 R2A, R3, R4 R2A R2A R3, R4 R3, R4 R2A R2A R4 R4 R2A, R3, R4 R2A	English/Metric (carriage/mounting) E = English carriage & mounting dimensions M = Metric carriage & mounting dimensions	Available R2A, R3, R4 R2A, R3, R4	Carriage (omit this field for R2A models) S = Single carriage Dxx = Dual carriage (xx = center distance between dual carriages in inches – contact customer support for lengths)	Available R3, R4 R3, R4	Mounting Style MF3 = Front & rear rectangular flanges MS1 = Side end angles MS5 = Adjustable feet MS6 = Side tapped mounting holes A = Side angle brackets B = Adjustable T-nuts C = Front & rear rectangular flanges	Available R2A R2A R2A R2A R3, R4 R3, R4 R3, R4	Motor Orientation <i>Belt options</i> AR = Motor housing rotated above/right BR = Motor housing rotated behind/right CR = Motor housing rotated under/right AL = Motor housing rotated above/left BL = Motor housing rotated behind/left CL = Motor housing rotated under/left <i>Screw options</i> I = Motor mounted inline P = Motor mounted parallel PR = Motor mounted parallel/right PL = Motor mounted parallel/left	Available R2A, R3, R4 R2A, R3, R4 R2A, R3, R4 R2A, R3, R4 R2A, R3, R4 R2A, R3, R4 R2A, R3, R4 R2A, R3, R4 R3, R4 R3, R4 R2A, R3, R4 R2A, R3, R4 R2A, R3, R4 R2A, R3, R4

* Contact customer support for AKM combinations outside of those listed.
** For custom lengths round up to next standard incremental plus add standard cut fee.
*** Contact customer support if CO is not selected.

Note: Options shown in bold blue text are considered standard.

Model Nomenclature

MODEL NOMENCLATURE

DS Series Precision Table

DS Series	Stroke Length	Grade	Ballscrew Lead	Motor Type*	Motor Options	Motor Mounts	Couplings	Motor Orient.	Limit Sensors	Home Switch	Shaft End Opt.	Linear Encoder	Options
DS4	250	C	5G	AKM23D	BNC	(-)	OE6	PR6E	LN1	H0	(-)	EO	CLN
<p>DS Series DS4 DS6</p> <p>Stroke Length 50 = 50 mm total stroke DS4 only 100 = 100 mm total stroke DS4 only 150 = 150 mm total stroke DS4 only 200 = 200 mm total stroke DS4 only 250 = 250 mm total stroke DS4 only 300 = 300 mm total stroke DS4 only 350 = 350 mm total stroke DS4 only 400 = 400 mm total stroke DS4 only 450 = 450 mm total stroke DS4 only 500 = 500 mm total stroke DS4 only 550 = 550 mm total stroke DS4 only 600 = 600 mm total stroke DS6 only 700 = 700 mm total stroke DS6 only 800 = 800 mm total stroke DS6 only 900 = 900 mm total stroke DS6 only 1000 = 1000 mm total stroke DS6 only 1250 = 1250 mm total stroke DS6 only 1500 = 1500 mm total stroke DS6 only 1750 = 1750 mm total stroke DS6 only 2000 = 2000 mm total stroke DS6 only</p> <p>Grade C = Commercial grade P = Precision grade**</p> <p>Ballscrew Lead 5G = 5 mm/rev 10G = 10 mm/rev 25G = 25 mm/rev (≥ 700 mm) DS6 only</p> <p>Motor Type* AKM23C = AKM23C-EFxxx-00 brushless servo AKM23D = AKM23D-EFxxx-00 brushless servo AKM42E = AKM42E-EKxxx-00 brushless servo DS6 only AKM42G = AKM42G-EKxxx-00 brushless servo DS6 only</p> <p>Motor Options* B ■ ■ = Rotatable IP65 connectors AKM2 only C ■ ■ = 0.5 m shielded cables w/ IP65 connectors AKM2 only C ■ ■ = Rotatable IP65 connectors AKM4, AKM5 only ■ N ■ = No brake ■ 2 ■ = 24 Vdc power-off holding brake ■ ■ R = Resolver ■ ■ 2 = 2048 LPR incremental comm. encoder ■ ■ C = Smart Feedback Device (SFD) ■ ■ DA = Single-turn absolute sine encoder, EnDat2.2, 01 ■ ■ DB = Multi-turn absolute sine encoder, EnDat2.2, 01</p> <p>Additional Options P1 = Standard pinning of x-axis carriage CLN = Cleanroom prep – class 100 Omit for no additional options</p> <p>Linear Encoder EO = No linear encoder E1 = 1.0 micron resolution E2 = 0.5 micron resolution E3 = 0.1 micron resolution</p> <p>Shaft End Options BS = Brake on ballscrew, 24 Vdc power-off ES = Rotary encoder on ballscrew, 1250 line Omit for no additional options</p> <p>Home Switch H0 = No home sensor HN1 = Home, NPN type normal open HN2 = Home, NPN type normal closed HP1 = Home, PNP type normal open HP2 = Home, PNP type normal closed</p> <p>Limit Sensors L0 = No end-of-travel limits LN1 = Limits, NPN type normal open LN2 = Limits, NPN type normal closed LP1 = Limits, PNP type normal open LP2 = Limits, PNP type normal closed</p> <p>Motor Orientation & Pulley Bore (Parallel Models) PR6E = Parallel right PL6E = Parallel left PU6E = Parallel under Omit if parallel model is not preferred</p> <p>Couplings (Inline Models) OE6 = Oldham style, 3/8" bore (AKM2X) OE8 = Oldham style, 1/2" bore (AKM4X) DS6 only BE6 = Bellows style, 3/8" bore (AKM2X) BE8 = Bellows style, 1/2" bore (AKM4X) DS6 only Omit for parallel models</p> <p>Motor Mounts X23 = NEMA 23 mount X34 = NEMA 34 mount DS6 only Omit if motor option is used</p>													

* Contact customer support for AKM combinations outside of those listed.
 ** Extended lead time required.
 Note 1: Options shown in bold blue text are considered standard.
 Note 2: Contact customer support for price and lead time on all non-standard features.

MOTIONEERING® Online

Announcing MOTIONEERING® Online – Kollmorgen has revamped, modernized and put online one of the most respected applications sizing programs of the last 20 years. You now can access this application sizing and selection tool where ever you have access to the internet. This initial launch of MOTIONEERING Online is just a start of a series of releases that will empower you to optimize solutions for your toughest applications. Sizing frameless motors and drive systems has never been easier. Using a mechanism project concept for collecting and saving multiple axes of load information, MOTIONEERING® Online can automatically calculate application results and compare against a catalog of systems - recommending the most optimized set of Kollmorgen system solutions available.

Versatile units-of-measure selection options for mechanism and motion profile data-entry, with the ability to convert data into other available units, makes this a convenient international tool. A user-friendly Help file teaches program functions and algorithms used to provide results.

Mechanism Projects

- Direct drive entry, lead screw, conveyor
- Rack and pinion, nip rolls
- Direct Drive Rotary
- Electric Cylinder
- Direct data entry



Solution Set Search Screen

- Color-coded indication of system's ability to meet application requirements
- Review system components specifications
- Save, print, or create a pdf application report
- Evaluate system performance curve with application points

MOTIONEERING® Online NEW and Improved Features:

- Inertia Calculator - lets you build up inertia based on odd shapes by additive or subtractive methods
- Custom motion profile - easy to add entire segments or copy segments to repeat
- Environmental Factor - takes into account your ambient temperature
- Project by Project Units - You can tailor your units on a project by project basis, or use the global units settings

MOTIONEERING Online Supported Browsers

- IE, Chrome, Firefox, Safari

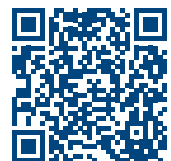

www.kollmorgen.com/motioneering