

## Rod Type



# Rod Type

**RCP4**

**ERC3**

**RCA2**

**RCP3**

**ERC2**

**RCA**

**RCP2**

**RCD**

**RCS2**

### Pulse Motor Type

<b>RCP4 series</b>	Standard Type	Coupling Type	52mm Width	RCP4-RA5C	<b>147</b>
			61mm Width	RCP4-RA6C	<b>149</b>
	Side-Mounted Motor Type		52mm Width	RCP4-RA5R	<b>151</b>
			61mm Width	RCP4-RA6R	<b>153</b>
<b>RCP3 series</b>	Mini Type	Coupling Type	22mm Width	RCP3-RA2AC	<b>155</b>
			28mm Width	RCP3-RA2BC	<b>157</b>
	Side-Mounted Motor Type		22mm Width	RCP3-RA2AR	<b>159</b>
			28mm Width	RCP3-RA2BR	<b>161</b>
<b>RCP2 series</b>	Standard Type	Coupling Type	25mm Width	RCP2-RA2C	<b>163</b>
			35mm Width	RCP2-RA3C	<b>165</b>
	High-Thrust Type	Coupling Type	85mm Width	RCP2-RA8C	<b>167</b>
		Side-Mounted Motor Type	85mm Width	RCP2-RA8R	<b>169</b>
	Short-Length Type	Coupling Type	100mm Width	RCP2-RA10C	<b>171</b>
		Standard Type	45mm Width	RCP2-SRA4R	<b>173</b>
Single-Guide Type		45mm Width	RCP2-SRGS4R	<b>175</b>	
	Double-Guide Type	45mm Width	RCP2-SRGD4R	<b>177</b>	

### Controller-Integrated Type with Pulse Motor

<b>ERC3 series</b>	Controller-Integrated Type	Standard Type	45mm Width	ERC3-RA4C	<b>179</b>
			64mm Width	ERC3-RA6C	<b>181</b>
<b>ERC2 series</b>	Controller-Integrated Type	Standard Type	58mm Width	ERC2-RA6C	<b>183</b>
			68mm Width	ERC2-RA7C	<b>185</b>
		Single-Guide Type	58mm Width	ERC2-RGS6C	<b>187</b>
			68mm Width	ERC2-RGS7C	<b>189</b>
		Double-Guide Type	58mm Width	ERC2-RGD6C	<b>191</b>
			68mm Width	ERC2-RGD7C	<b>193</b>

### DC Brushless Motor Type

<b>RCD series</b>	Mini Cylinder	12mm Width	RCD-RA1D	<b>195</b>
-------------------	---------------	------------	----------	------------

**145** Rod Type

Sold & Serviced By:

Toll Free Phone (877) SERV098  
 Toll Free Fax (877) SERV099  
[www.electromate.com](http://www.electromate.com)  
[sales@electromate.com](mailto:sales@electromate.com)

# Rod Type

- Slider Type
- Mini
- Standard
- Controller Integrated
- Rod Type
- Mini
- Standard
- Controllers Integrated
- Table/Arm/Flat Type
- Mini
- Standard
- Gripper/Rotary Type
- Linear Servo Type
- Clean-room Type
- Splash-Proof Type
- Pulse Motor
- Servo Motor (24V)
- Servo Motor (200V)
- Linear Servo Motor

<b>RCA2 series</b> 24V Servo Motor Type	Mini Rod Type	Coupling Type	18mm Width	RCA2-RA2AC	<b>197</b>	
		Side-Mounted Motor Type	18mm Width	RCA2-RA2AR	<b>199</b>	
		Short-Length Type	28mm Width	RCA2-RN3NA	<b>201</b>	
			34mm Width	RCA2-RN4NA	<b>203</b>	
			28mm Width	RCA2-RP3NA	<b>205</b>	
		34mm Width	RCA2-RP4NA	<b>207</b>		
	Single-Guide Type	28mm Width	RCA2-GS3NA	<b>209</b>		
		34mm Width	RCA2-GS4NA	<b>211</b>		
	Double-Guide Type	28mm Width	RCA2-GD3NA	<b>213</b>		
		34mm Width	RCA2-GD4NA	<b>215</b>		
	Slide Unit Type	60mm Width	RCA2-SD3NA	<b>217</b>		
		72mm Width	RCA2-SD4NA	<b>219</b>		
<b>RCA series</b> 24V Servo Motor Type	Standard Type	Coupling Type	ø32mm	RCA-RA3C	<b>221</b>	
			ø37mm	RCA-RA4C	<b>223</b>	
		Build-in Type	ø32mm	RCA-RA3D	<b>225</b>	
			ø37mm	RCA-RA4D	<b>227</b>	
		Side-Mounted Motor Type	ø32mm	RCA-RA3R	<b>229</b>	
			ø37mm	RCA-RA4R	<b>231</b>	
	Short-Length Type	45mm Width	RCA-SRA4R	<b>233</b>		
		Single-Guide Type	Coupling Type	ø32mm	RCA-RGS3C	<b>235</b>
				ø37mm	RCA-RGS4C	<b>237</b>
	Build-in Type	ø32mm	RCA-RGS3D	<b>239</b>		
		ø37mm	RCA-RGS4D	<b>241</b>		
		Short-Length Type	45mm Width	RCA-SRGS4R	<b>243</b>	
	Double-Guide Type	Coupling Type	ø32mm	RCA-RGD3C	<b>245</b>	
			ø37mm	RCA-RGD4C	<b>247</b>	
		Build-in Type	ø32mm	RCA-RGD3D	<b>249</b>	
			ø37mm	RCA-RGD4D	<b>251</b>	
		Side-Mounted Motor Type	ø32mm	RCA-RGD3R	<b>253</b>	
			ø37mm	RCA-RGD4R	<b>255</b>	
Short-Length Type	45mm Width	RCA-SRGD4R	<b>257</b>			
<b>RCS2 series</b> 200V Servo Motor Type	Mini Rod Type	Short-Length Type	46mm Width	RCS2-RN5N	<b>259</b>	
			46mm Width	RCS2-RP5N	<b>261</b>	
			46mm Width	RCS2-GS5N	<b>263</b>	
			46mm Width	RCS2-GD5N	<b>265</b>	
			94mm Width	RCS2-SD5N	<b>267</b>	
	Standard Type	Coupling Type	ø37mm	RCS2-RA4C	<b>269</b>	
			55mm Width	RCS2-RA5C	<b>271</b>	
		Build-in Type	ø37mm	RCS2-RA4D	<b>273</b>	
		Short-Length Type	75mm Width	RCS2-SRA7BD	<b>275</b>	
		Side-Mounted Motor Type	ø37mm	RCS2-RA4R	<b>277</b>	
	55mm Width		RCS2-RA5R	<b>279</b>		
	130mm Width		RCS2-RA13R	<b>281</b>		
	Single-Guide Type	Coupling Type	ø37mm	RCS2-RGS4C	<b>283</b>	
			55mm Width	RCS2-RGS5C	<b>285</b>	
		Build-in Type	ø37mm	RCS2-RGS4D	<b>287</b>	
	Short-Length Type	75mm Width	RCS2-SRGS7BD	<b>289</b>		
	Double-Guide Type	Coupling Type	ø37mm	RCS2-RGD4C	<b>291</b>	
			55mm Width	RCS2-RGD5C	<b>293</b>	
Build-in Type		ø37mm	RCS2-RGD4D	<b>295</b>		
Short-Length Type		75mm Width	RCS2-SRGD7BD	<b>297</b>		
Side-Mounted Motor Type	ø37mm	RCS2-RGD4R	<b>299</b>			

# RCP4-RA5C

ROBO Cylinder, Rod Type, Motor Unit Coupled, Actuator Width 52mm, 24-V Pulse Motor

Model Specification Items	<b>RCP4</b>	<b>RA5C</b>	<b>I</b>	<input type="checkbox"/>	<input type="checkbox"/>	<input type="checkbox"/>	<b>P3</b>	<input type="checkbox"/>	<input type="checkbox"/>
	Series	Type	Encoder type	Motor type	Lead	Stroke	Applicable controller	Cable length	Options
			I: Incremental	42P: Pulse motor, size 42□ 42SP: High-thrust pulse motor size 42□	20: 20mm 12: 12mm 6: 6mm 3: 3mm	50: 50mm 400: 400mm (50mm pitch increments)	P3: PCON-CA MSEP-C	N: None P: 1m S: 3m M: 5m X□□: Custom length R□□: Robot cable	See Options below.  * If the high-thrust pulse motor is selected, the actuator comes standard with option B (Brake).

\* See page Pre-47 for details on the model descriptions.

## Built-in guide mechanism

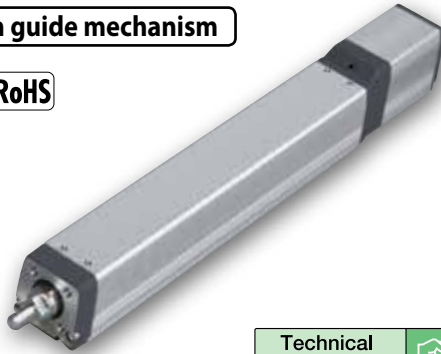

Technical References Appendix P.5



- The maximum payload is the value when operated at 0.3G (0.2G with some models) acceleration. The upper limit of acceleration is 1G (\*). Note that raising the acceleration causes the payload to drop. (\*): The specific value varies depending on the connected controller and actuator lead. For details, refer to "Selection References" on page A-101 and A-103.
- Take note that the maximum payload and maximum speed vary depending on the controller connected to the RCP4. (Refer to the actuator specifications below.)
- All horizontal payloads are values when an external guide is used.
- See page A-71 for details on push motion.

## Correlation Diagrams of Speed and Payload

\* The values of the horizontal specification assume that an external guide is used.

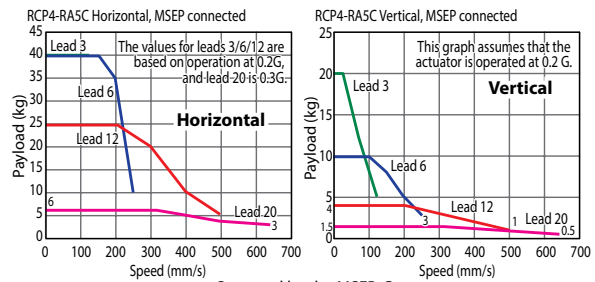
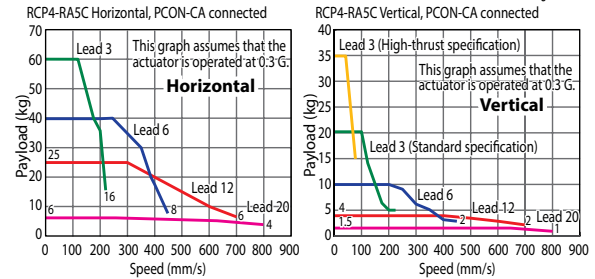

## Actuator Specifications

### Leads and Payloads

(\*) When operated at 0.2 G

Model number	Lead (mm)	Connected controller	Maximum payload		Max. push force (N)	Stroke (mm)
			Horizontal (kg)	Vertical (kg)		
Standard specification	20	PCON-CA	6	1.5	56	50 to 400 (every 50mm)
		MSEP-C	6	1.5 (*)		
	12	PCON-CA	25	4	93	
		MSEP-C	25 (*)	4 (*)		
6	PCON-CA	40	10	185		
	MSEP-C	40 (*)	10 (*)			
3	PCON-CA	60	20	370		
	MSEP-C	40 (*)	10 (*)			
High-thrust specification	3	PCON-CA	—	35	750	

### Stroke and Maximum Speed

Lead (mm)	Stroke	
	Connected controller	50~400 (every 50mm)
20	PCON-CA	800
	MSEP-C	640
12	PCON-CA	700
	MSEP-C	500
6	PCON-CA	450
	MSEP-C	250
3 (Standard)	PCON-CA	225
	MSEP-C	125
3 (High-thrust)	PCON-CA	80

Code explanation ① Stroke ② Cable length ③ Options \*See page A-71 for details on push motion.

(Unit: mm/s)

### ① Stroke

Stroke (mm)	Standard price	
	Standard	High-thrust
50	—	—
100	—	—
150	—	—
200	—	—
250	—	—
300	—	—
350	—	—
400	—	—

### ② Cable Length

Type	Cable symbol	Standard price
Standard type	P (1m)	—
	S (3m)	—
	M (5m)	—
Special length	X06 (6m) ~ X10 (10m)	—
	X11 (11m) ~ X15 (15m)	—
	X16 (16m) ~ X20 (20m)	—
	R01 (1m) ~ R03 (3m)	—
Robot cable	R04 (4m) ~ R05 (5m)	—
	R06 (6m) ~ R10 (10m)	—
	R11 (11m) ~ R15 (15m)	—
	R16 (16m) ~ R20 (20m)	—
	—	—

\* See page A-59 for cables for maintenance.

### ③ Options

Name	Option code	Page	Standard Price
Brake	B	→ A-42	—
Optional cable exit direction (top)	CJT	→ A-42	—
Optional cable exit direction (right)	CJR	→ A-42	—
Optional cable exit direction (left)	CJL	→ A-42	—
Optional cable exit direction (bottom)	CJB	→ A-42	—
Flange bracket	FL	→ A-44	—
Non-motor end specification	NM	→ A-52	—
Scraper	SC	→ A-55	—

### Actuator Specifications

Item	Description
Drive method	Ball screw, ø10mm, rolled C10
Positioning repeatability (*1)	±0.02mm [±0.03mm]
Lost motion	0.1mm or less
Rod	ø22mm stainless steel pipe
Rod non-rotation precision	±0 deg
Allowable rod load mass	Refer to page 148 and page A-117
Rod tip overhang distance	100mm or less
Ambient operating temperature/humidity	0 to 40°C, 85% RH max. (Non-condensing)

(\*1) The value at lead 20 is shown in [ ].

- Slider Type
- Mini
- Standard
- Controller Integrated
- Rod Type
- Mini
- Standard
- Controllers Integrated
- Table/Arm/Flat Type
- Mini
- Standard
- Gripper/Rotary Type
- Linear Servo Type
- Clean-room Type
- Splash-Proof Type
- Pulse Motor
- Servo Motor (24V)
- Servo Motor (200V)
- Linear Servo Motor

Dimensional Drawings

CAD drawings can be downloaded from the website. [www.intelligentactuator.com](http://www.intelligentactuator.com)



- (\*1) Connect the motor-encoder integrated cable here.
  - (\*2) During home return, be careful to avoid interference from peripheral objects because the slider travels until the mechanical end. Also, please note that the lengths between Home and ME, SE and ME are 2mm for the high-thrust specification.
  - (\*3) The orientation of the bolt varies depending on the product.
  - (\*4) If the actuator is installed using the front housing and flange, make sure the actuator will not receive any external force.
- ME : Mechanical end  
SE : Stroke end

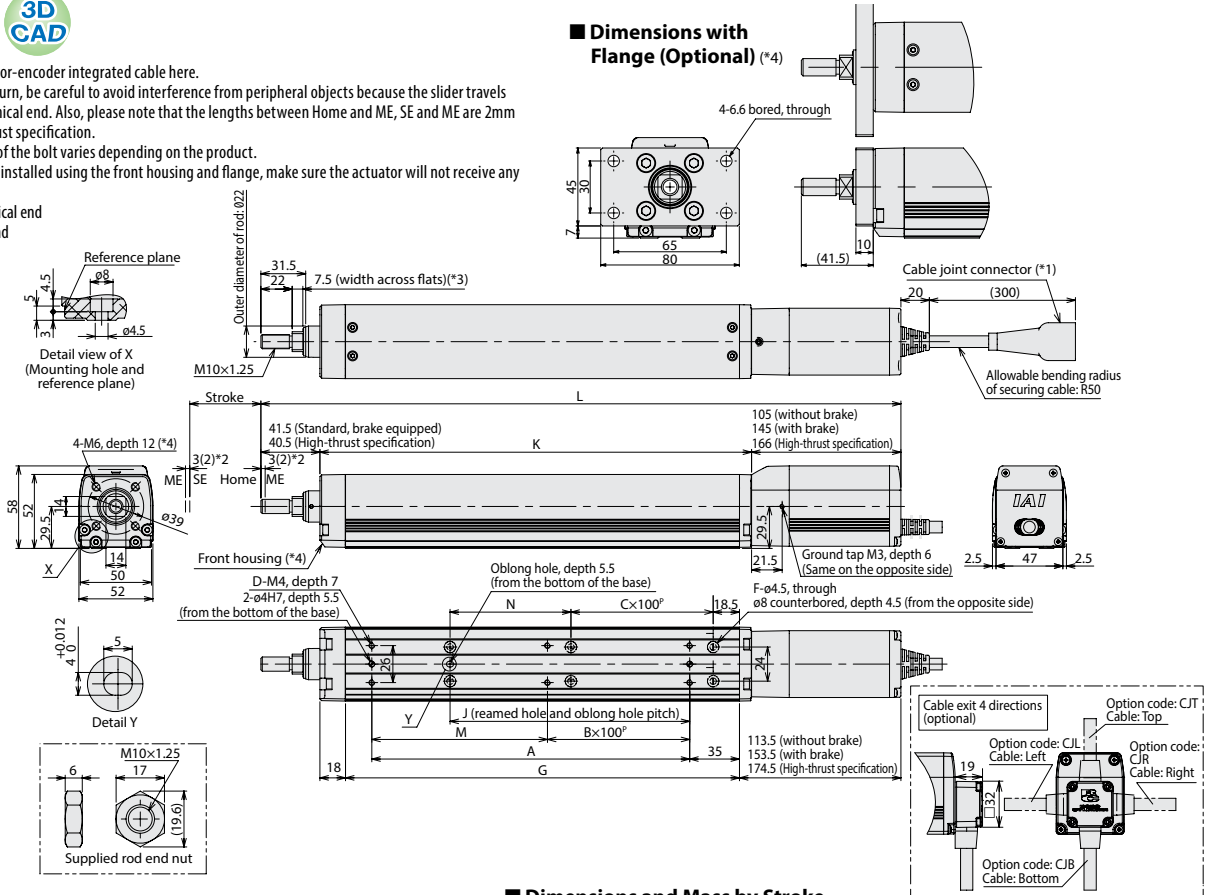

**Rod Deflection of RCP4-RA5C (Reference Values)**

(The graph below plots deflection as measured by installing the actuator vertically and applying a force to the rod from one side.)

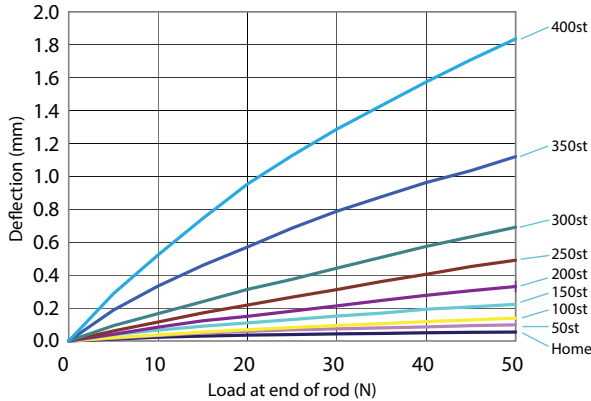

**Dimensions and Mass by Stroke**

Stroke	Stroke									
	50	100	150	200	250	300	350	400		
L	Without brake	300	350	400	450	500	550	600	650	
	With brake	340	390	440	490	540	590	640	690	
	High-thrust specification	360	410	460	510	560	610	660	710	
A	73.5	123.5	173.5	223.5	273.5	323.5	373.5	423.5		
B	0	0	1	1	2	2	3	3		
C	0	0	0	1	1	2	2	3		
D	4	4	6	6	8	8	10	10		
F	4	4	4	6	6	8	8	10		
G	127	177	227	277	327	377	427	477		
J	18.5	68.5	118.5	168.5	218.5	268.5	318.5	368.5		
K	153.5	203.5	253.5	303.5	353.5	403.5	453.5	503.5		
M	73.5	123.5	173.5	223.5	273.5	323.5	373.5	423.5		
N	35	85	135	185	235	285	335	385		
Allowable static load at end of rod (N)	Without brake	65.6	51.2	41.7	34.9	29.8	25.7	22.4	19.7	
	With brake	32.4	23.6	18.1	14.4	11.6	9.5	7.7	6.2	
Allowable dynamic load at end of rod (N)	Load offset 0mm	25.6	19.7	15.7	12.7	10.4	8.6	7.1	5.7	
	Load offset 100mm	6.6	5.2	4.3	3.7	3.2	2.8	2.6	2.3	
Allowable static torque at end of rod (N-m)	Without brake	2.6	2.0	1.6	1.3	1.0	0.9	0.7	0.6	
	With brake	1.9	2.1	2.4	2.7	2.9	3.2	3.4	3.7	
Weight (kg)	Without brake	1.9	2.1	2.4	2.7	2.9	3.2	3.4	3.7	
	With brake	2.1	2.4	2.6	2.9	3.1	3.4	3.7	3.9	

**Applicable Controllers**

RCP4 series actuators can be operated with the controllers indicated below. Select the type according to your intended application.

Name	External view	Model number	Features	Maximum number of positioning points	Input power	Power supply capacity	Standard price	Reference page
Positioner type High-output specification		PCON-CA-42○I-○-2-0	Equipped with a high-output driver PIO control supported	512 points	DC24V	Refer to P618	—	→ P607
Pulse-train type High-output specification		PCON-CA-42○I-PL□-2-0	Equipped with a high-output driver Pulse-train input supported	—				
Field network type High-output specification		PCON-CA-42○I-○-0-0	Equipped with a high-output driver Field network supported	768 points				
Solenoid valve multi-axis type PIO specification		MSEP-C-○-○-○-2-0	Positioner type based on PIO control, allowing up to 8 axes to be connected	3 points	Refer to P572	—	—	→ P563
Solenoid valve multi-axis type Network specification		MSEP-C-○-○-○-0-0	Field network-ready positioner type, allowing up to 8 axes to be connected	256 points				

\* ○ indicates I/O type (NP/PN). \* ◎ indicates number of axes (1 to 8). \* ◎ indicates field network specification symbol. \* □ indicates N (NPN specification) or P (PNP specification) symbol. \* ○ indicates P (Standard specification) or SP (High-thrust specification) symbol.

# RCP4-RA6C

ROBO Cylinder, Rod Type, Motor Unit Coupled, Actuator Width 61mm, 24-V Pulse Motor

Model Specification Items	<b>RCP4</b>	<b>SA6C</b>	<b>I</b>						
	Series	Type	Encoder type	Motor type	Lead	Stroke	Applicable controller	Cable length	Options
			I: Incremental	56P: Pulse motor, size 56□ 56SP: High-thrust pulse motor size 56□	24: 24mm 16: 16mm 8: 8mm 4: 4mm	50: 50mm ? 500: 500mm (50mm pitch increments)	P3: PCON-CA MSEP-C P4: PCON-CFA	N: None P: 1m S: 3m M: 5m X□□: Custom length R□□: Robot cable	See Options below.  * If the high-thrust pulse motor is selected, the actuator comes standard with option B (Brake).

\* See page Pre-47 for details on the model descriptions.

## Built-in guide mechanism

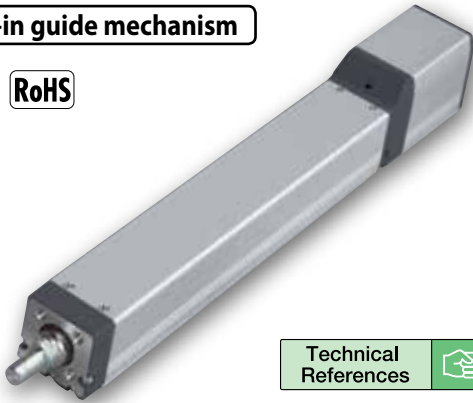

Technical References Appendix P.5



- The maximum payload is the value when operated at 0.3G (0.2G with some models) acceleration. The upper limit of acceleration is 1G (\*). Note that raising the acceleration causes the payload to drop. (\* ) The specific value varies depending on the connected controller and actuator lead. For details, refer to "Selection References" on page A-101 and A-103.
- Take note that the maximum payload and maximum speed vary depending on the controller connected to the RCP4. (Refer to the actuator specifications below.)
- All horizontal payloads are values when an external guide is used.
- See page A-71 for details on push motion.

## Correlation Diagrams of Speed and Payload

\* The values of the horizontal specification assume that an external guide is used.

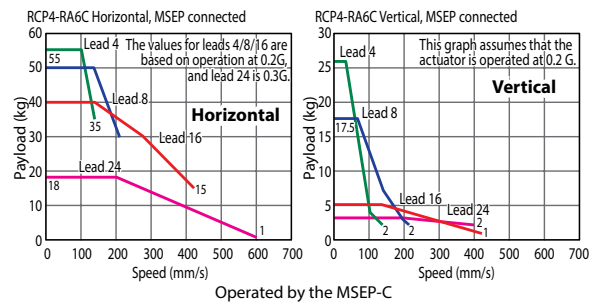
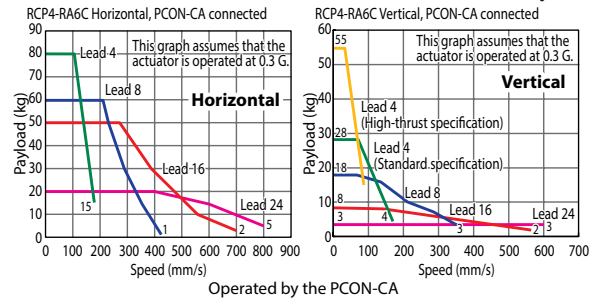

## Actuator Specifications

### Leads and Payloads

Model number	Lead (mm)	Connected controller	Maximum payload		Max. push force (N)	Stroke (mm)
			Horizontal (kg)	Vertical (kg)		
Standard specification	24	PCON-CA	20	3	182	50 to 500 (every 50mm)
		MSEP-C	18	3 (*)		
	16	PCON-CA	50	8	273	
		MSEP-C	40 (*)	5 (*)		
8	PCON-CA	60	18	547		
	MSEP-C	50 (*)	17.5 (*)			
4	PCON-CA	80	28	1094		
	MSEP-C	55 (*)	26 (*)			
High-thrust specification	4	PCON-CFA	—	55	1106	

(\*) When operated at 0.2 G

### Stroke and Maximum Speed

Lead (mm)	Connected controller	Stroke (mm)	50~500 (every 50mm)
			24
	MSEP-C	600<400>	
16	PCON-CA	700<560>	
	MSEP-C	420	
8	PCON-CA	420	
	MSEP-C	210	
4 (Standard)	PCON-CA	210	
	MSEP-C	140	
4 (High-thrust)	PCON-CFA	90	

The values in <> apply when the actuator is used vertically. (Unit: mm/s)

Code explanation ① Stroke ② Cable length ③ Options \*See page A-71 for details on push motion.

### ① Stroke

Stroke (mm)	Standard price	
	Standard	High-thrust
50	—	—
100	—	—
150	—	—
200	—	—
250	—	—
300	—	—
350	—	—
400	—	—
450	—	—
500	—	—

### ② Cable Length

Type	Cable symbol	Standard price
Standard type	P (1m)	—
	S (3m)	—
	M (5m)	—
Special length	X06 (6m) ~ X10 (10m)	—
	X11 (11m) ~ X15 (15m)	—
	X16 (16m) ~ X20 (20m)	—
	R01 (1m) ~ R03 (3m)	—
Robot cable	R04 (4m) ~ R05 (5m)	—
	R06 (6m) ~ R10 (10m)	—
	R11 (11m) ~ R15 (15m)	—
	R16 (16m) ~ R20 (20m)	—
	R20 (20m)	—

\* See page A-59 for cables for maintenance.

### ③ Options

Name	Option code	Page	Standard Price
Brake	B	→ A-42	—
Optional cable exit direction (top)	CJT	→ A-42	—
Optional cable exit direction (right)	CJR	→ A-42	—
Optional cable exit direction (left)	CJL	→ A-42	—
Optional cable exit direction (bottom)	CJB	→ A-42	—
Flange bracket	FL	→ A-44	—
Non-motor end specification	NM	→ A-52	—
Scraper	SC	→ A-55	—

## Actuator Specifications

Item	Description
Drive method	Ball screw, ø12mm, rolled C10
Positioning repeatability (*1)	±0.02mm [±0.03mm]
Lost motion	0.1mm or less
Rod	ø25mm stainless steel pipe
Rod non-rotation precision	±0 deg
Allowable rod load mass	Refer to page 150 and page A-117
Rod tip overhang distance	100mm or less
Ambient operating temperature/humidity	0 to 40°C, 85% RH max. (Non-condensing)

(\*1) The value at lead 24 is shown in [ ].

Dimensional Drawings

CAD drawings can be downloaded from the website.

www.intelligentactuator.com



- (\*1) Connect the motor-encoder integrated cable here.
  - (\*2) During home return, be careful to avoid interference from peripheral objects because the slider travels until the mechanical end. Also, please note that the lengths between Home and ME, SE and ME are 2mm for the high-thrust specification.
  - (\*3) The orientation of the bolt varies depending on the product.
  - (\*4) If the actuator is installed using the front housing and flange, make sure the actuator will not receive any external force.
- ME: Mechanical end  
SE: Stroke end

For Special Orders

Appendix P.15

Dimensions with Flange (Optional) (\*4)

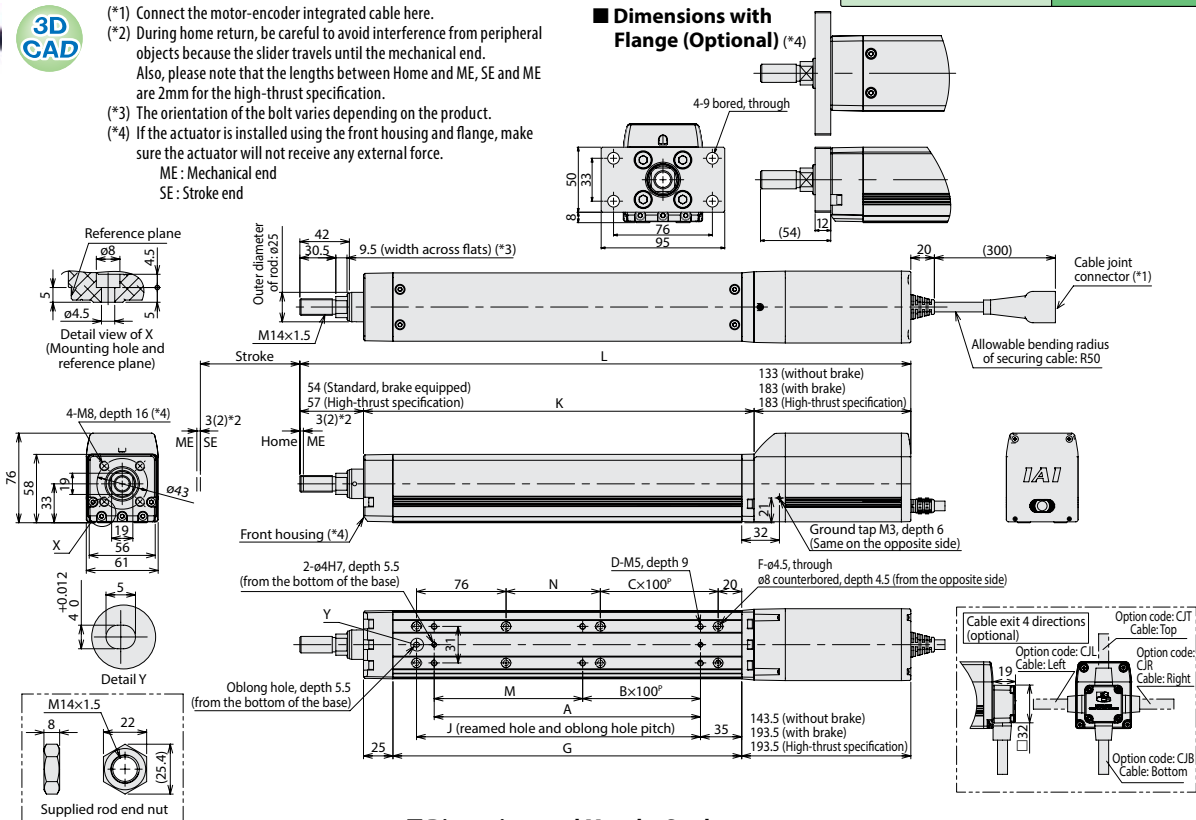

Rod Deflection of RCP4-RA6C (Reference Values)

(The graph below plots deflection as measured by installing the actuator vertically and applying a force to the rod from one side.)

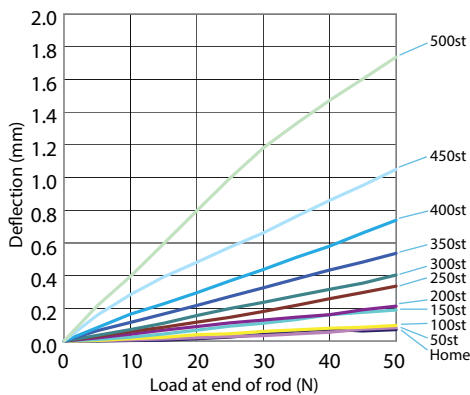

Dimensions and Mass by Stroke

Stroke	Stroke										
	50	100	150	200	250	300	350	400	450	500	
L	Without brake	368.5	418.5	468.5	518.5	568.5	618.5	668.5	718.5	768.5	818.5
	With brake	418.5	468.5	518.5	568.5	618.5	668.5	718.5	768.5	818.5	868.5
	High-thrust specification	421.5	471.5	521.5	571.5	621.5	671.5	721.5	771.5	821.5	871.5
A	76	126	176	226	276	326	376	426	476	526	
B	0	0	1	1	2	2	3	3	4	4	
C	0	0	0	1	1	2	2	3	3	4	
D	4	4	6	6	8	8	10	10	12	12	
F	6	6	6	8	8	10	10	12	12	14	
G	146	196	246	296	346	396	446	496	546	596	
J	91	141	191	241	291	341	391	441	491	541	
K	181.5	231.5	281.5	331.5	381.5	431.5	481.5	531.5	581.5	631.5	
M	76	126	176	226	276	326	376	426	476	526	
N	30	80	130	80	130	80	130	80	130	80	
Allowable static load at end of rod (N)	112.7	91.5	76.7	65.7	57.2	50.4	44.8	40.2	36.2	32.7	
Allowable dynamic load at end of rod (N)	Load offset 0mm	49.0	37.4	29.9	24.5	20.4	17.1	14.5	12.3	10.3	8.6
	Load offset 100mm	38.7	31.0	25.5	21.4	18.1	15.4	13.2	11.2	9.5	8.0
Allowable static torque at end of rod (N-m)	11.4	9.3	7.9	6.8	6.0	5.4	4.9	4.5	4.1	3.8	
Allowable dynamic torque at end of rod (N-m)	3.9	3.1	2.5	2.1	1.8	1.5	1.3	1.1	1.0	0.8	
Weight (kg)	Without brake	3.4	3.7	4.1	4.4	4.7	5.0	5.4	5.7	6.0	6.3
	With brake	3.9	4.2	4.6	4.9	5.2	5.5	5.9	6.2	6.5	6.8

Applicable Controllers

RCP4 series actuators can be operated with the controllers indicated below. Select the type according to your intended application.

Name	External view	Model number	Features	Maximum number of positioning points	Input power	Power supply capacity	Standard price	Reference page
Positioner type High-output specification		PCON-CA-56PI-①-2-0	Equipped with a high-output driver PIO control supported	512 points	DC24V	Refer to P618	—	→ P607
Pulse-train type High-output specification		PCON-CA-56PI-PL-□-2-0	Equipped with a high-output driver Pulse-train input supported	—				
Field network type High-output specification		PCON-CA-56PI-⑩-0-0	Equipped with a high-output driver Field network supported	768 points				
Solenoid valve multi-axis type PIO specification		MSEP-C-①-①-①-2-0	Positioner type based on PIO control, allowing up to 8 axes to be connected	3 points	DC24V	Refer to P572	—	→ P563
Solenoid valve multi-axis type Network specification		MSEP-C-①-①-⑩-0-0	Field network-ready positioner type, allowing up to 8 axes to be connected	256 points				
Positioner type		PCON-CFA-56SPI-①-2-0	High-thrust specification Positioner type based on PIO control	512 points	DC24V	Refer to P618	—	→ P607
Pulse-train type		PCON-CFA-56SPI-PL-□-2-0	High-thrust specification Pulse-train input type	—				
Field network type		PCON-CFA-56SPI-⑩-0-0	High-thrust specification Supporting 7 major field networks	768 points				

\* ① indicates I/O type (NP/PN). \* ⑩ indicates number of axes (1 to 8). \* ⑩ indicates field network specification symbol. \* □ indicates N (NPN specification) or P (PNP specification) symbol.



RCP4-RA6C

150  
Sole & Service

ELECTROMATE

Toll Free Phone (877) SERV098  
Toll Free Fax (877) SERV099  
www.electromate.com  
sales@electromate.com

Slider Type

Mini

Standard

Controller Integrated

Rod Type

Mini

Standard

Controllers Integrated

Table/ Arm/ Flat Type

Mini

Standard

Gripper/ Rotary Type

Linear Servo Type

Clean-room Type

Splash-Proof Type

Pulse Motor

Servo Motor (24V)

Servo Motor (200V)

Linear Servo Motor

# RCP4-RA5R

ROBO Cylinder, Rod Type, Side-mounted Motor, Actuator Width 52mm, 24-V Pulse Motor

<b>Model Specification Items</b>	<b>RCP4</b> — <b>RA5R</b> — <b>I</b> — <b>42P</b> — [ ] — [ ] — <b>P3</b> — [ ] — [ ]
Series — Type — Encoder type — Motor type — Lead — Stroke — Applicable controller — Cable length — Options	I: Incremental 42P: Pulse motor, size 42□ 20: 20mm 12: 12mm 6: 6mm 3: 3mm 50: 50mm } 400: 400mm (50mm pitch increments) P3: PCON-CA MSEP-C N: None P: 1m S: 3m M: 5m X□: Custom length R□: Robot cable See Options below. * Be sure to specify either "ML" or "MR" as the motor side-mounted direction.

\* See page Pre-47 for details on the model descriptions.

### Built-in guide mechanism



The "Motor side-mounted to the left (ML)" option is selected for the actuator shown above.

**Technical References** Appendix P.5

- POINT** Notes on selection
- The maximum payload is the value when operated at 0.3G (0.2G with some models) acceleration. The upper limit of acceleration is 1 G (\*). Note that raising the acceleration causes the payload to drop. (\*) The specific value varies depending on the connected controller and actuator lead. For details, refer to "Selection References" on page A-105 and A-107.
  - Take note that the maximum payload and maximum speed vary depending on the controller connected to the RCP4. (Refer to the actuator specifications below.)
  - All horizontal payloads are values when an external guide is used.
  - See page A-71 for details on push motion.

### Correlation Diagrams of Speed and Payload

\* The values of the horizontal specification assume that an external guide is used.

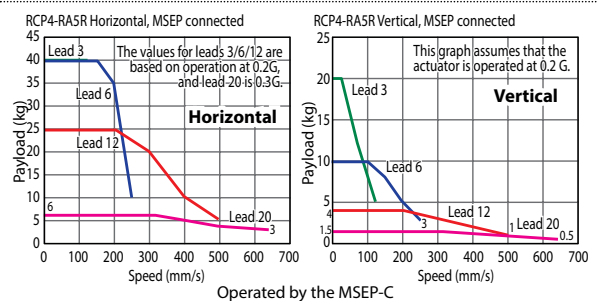
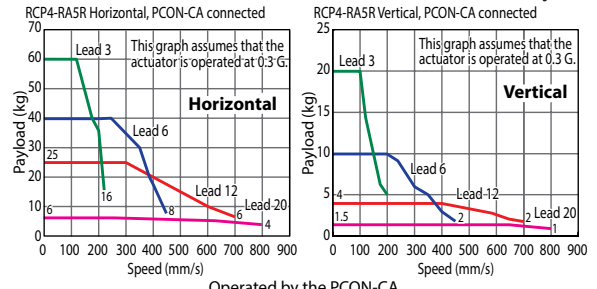

### Actuator Specifications

Model number	Lead (mm)	Connected controller	Maximum payload (*) When operated at 0.2 G		Max. push force (N)	Stroke (mm)	Stroke and Maximum Speed	
			Horizontal (kg)	Vertical (kg)			Lead (mm)	Stroke (mm) 50~400 (every 50mm)
RCP4-RA5R-I-42P-20-①-P3-②-③	20	PCON-CA	6	1.5	56	50 to 400 (every 50mm)	PCON-CA	800
		MSEP-C	6	1.5 (*)			MSEP-C	640
RCP4-RA5R-I-42P-12-①-P3-②-③	12	PCON-CA	25	4	93		PCON-CA	700
		MSEP-C	25 (*)	4 (*)			MSEP-C	500
RCP4-RA5R-I-42P-6-①-P3-②-③	6	PCON-CA	40	10	185		PCON-CA	450
		MSEP-C	40 (*)	10 (*)			MSEP-C	250
RCP4-RA5R-I-42P-3-①-P3-②-③	3	PCON-CA	60	20	370		PCON-CA	225
		MSEP-C	40 (*)	20 (*)			MSEP-C	125

Code explanation ① Stroke ② Cable length ③ Options \*See page A-71 for details on push motion. (Unit: mm/s)

#### ① Stroke

Stroke (mm)	Standard price
50	—
100	—
150	—
200	—
250	—
300	—
350	—
400	—

#### ③ Options

Name	Option code	Page	Standard Price
Brake (*)	B	→ A-42	—
Optional cable exit direction (top)	CJT	→ A-42	—
Optional cable exit direction (outside)	CJO	→ A-42	—
Optional cable exit direction (bottom)	CJB	→ A-42	—
Flange bracket (*)	FL	→ A-44	—
Motor side-mounted to the left (Standard)	ML	→ A-52	—
Motor side-mounted to the Right	MR	→ A-52	—
Non-motor end specification	NM	→ A-52	—
Scraper	SC	→ A-55	—

\* With brake option at 50 stroke, flange bracket can not be used because flange and motor cover may interfere.

#### ② Cable Length

Type	Cable symbol	Standard price
Standard type	P (1m)	—
	S (3m)	—
	M (5m)	—
Special length	X06 (6m) ~ X10 (10m)	—
	X11 (11m) ~ X15 (15m)	—
	X16 (16m) ~ X20 (20m)	—
	R01 (1m) ~ R03 (3m)	—
Robot cable	R04 (4m) ~ R05 (5m)	—
	R06 (6m) ~ R10 (10m)	—
	R11 (11m) ~ R15 (15m)	—
	R16 (16m) ~ R20 (20m)	—

\* See page A-59 for cables for maintenance.

### Actuator Specifications

Item	Description
Drive method	Ball screw, ø10mm, rolled C10
Positioning repeatability (*1)	±0.02mm [±0.03mm]
Lost motion	0.1mm or less
Rod	ø22mm stainless steel pipe
Rod non-rotation precision	±0 deg
Allowable rod load mass	Refer to page 152 and page A-117
Rod tip overhang distance	100mm or less
Ambient operating temperature/humidity	0 to 40°C, 85% RH max. (Non-condensing)

(\*1) The value at lead 20 is shown in [ ].

Dimensional Drawings

CAD drawings can be downloaded from the website.

www.intelligentactuator.com



- (\*1) Connect the motor-encoder integrated cable here.
  - (\*2) During home return, be careful to avoid interference from peripheral objects because the slider travels until the mechanical end.
  - (\*3) The orientation of the bolt varies depending on the product.
  - (\*4) If the actuator is installed using the front housing and flange, make sure the actuator will not receive any external force.
- ME : Mechanical end  
SE : Stroke end

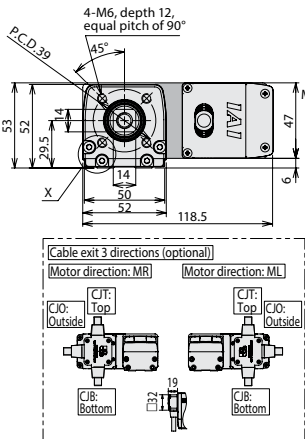
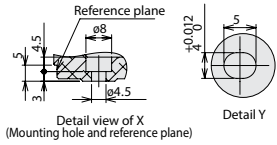

Dimensions with Flange (Optional) (\*4)

\*With brake option at 50 stroke, flange bracket can not be used because flange and motor cover may interfere.

For Special Orders

Appendix P.15

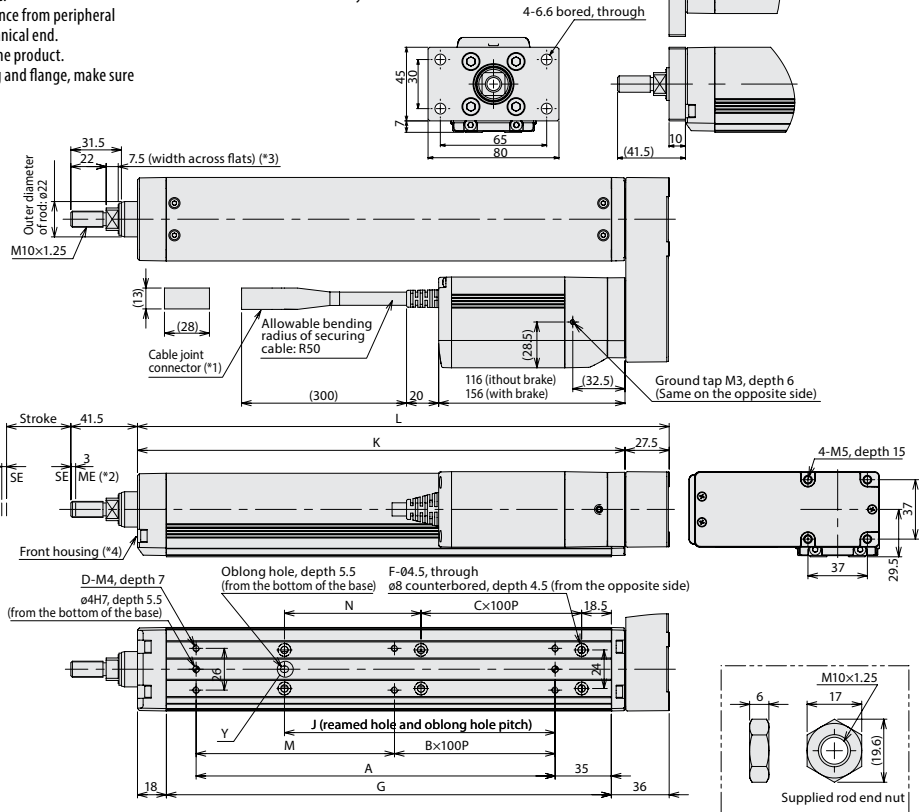

Rod Deflection of RCP4-RA5R (Reference Values)

(The graph below plots deflection as measured by installing the actuator vertically and applying a force to the rod from one side.)

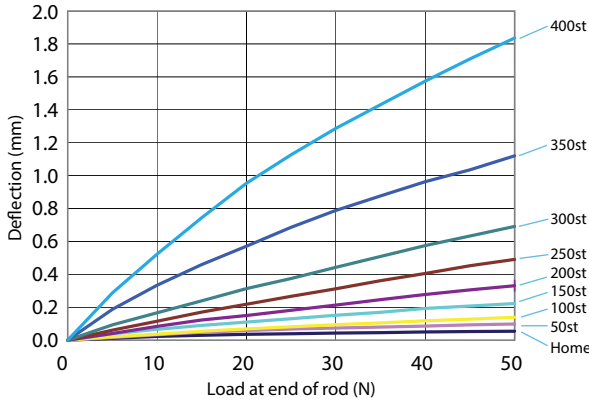

Dimensions and Mass by Stroke

Stroke	50	100	150	200	250	300	350	400	
L	181	231	281	331	381	431	481	531	
A	73.5	123.5	173.5	223.5	273.5	323.5	373.5	423.5	
B	0	0	1	1	2	2	3	3	
C	0	0	0	1	1	2	2	3	
D	4	4	6	6	8	8	10	10	
F	4	4	4	6	6	8	8	10	
G	127	177	227	277	327	377	427	477	
J	18.5	68.5	118.5	168.5	218.5	268.5	318.5	368.5	
K	153.5	203.5	253.5	303.5	353.5	403.5	453.5	503.5	
M	73.5	123.5	173.5	223.5	273.5	323.5	373.5	423.5	
N	35	85	135	85	135	85	135	85	
Allowable static load at end of rod (N)	65.6	51.2	41.7	34.9	29.8	25.7	22.4	19.7	
Allowable dynamic load at end of rod (N)	Load offset 0mm	32.4	23.6	18.1	14.4	11.6	9.5	7.7	6.2
	Load offset 100mm	25.6	19.7	15.7	12.7	10.4	8.6	7.1	5.7
Allowable static torque at end of rod (N-m)	6.6	5.2	4.3	3.7	3.2	2.8	2.6	2.3	
Allowable dynamic torque at end of rod (N-m)	2.6	2.0	1.6	1.3	1.0	0.9	0.7	0.6	
Weight (kg)	Without brake	2.1	2.4	2.6	2.9	3.2	3.4	3.7	4.0
	With brake	2.3	2.6	2.9	3.1	3.4	3.7	3.9	4.2

Applicable Controllers

RCP4 series actuators can be operated with the controllers indicated below. Select the type according to your intended application.

Name	External view	Model number	Features	Maximum number of positioning points	Input power	Power supply capacity	Standard price	Reference page		
Positioner type High-output specification		PCON-CA-42PI-①-2-0	Equipped with a high-output driver PIO control supported	512 points	DC24V	Refer to P618	—	→ P607		
Pulse-train type High-output specification		PCON-CA-42PI-PL-□-2-0	Equipped with a high-output driver Pulse-train input supported	—						
Field network type High-output specification		PCON-CA-42PI-③-0-0	Equipped with a high-output driver Field network supported	768 points						
Solenoid valve multi-axis type PIO specification	MSEP-C-④-⑤-⑥-2-0	Positioner type based on PIO control, allowing up to 8 axes to be connected	3 points	Refer to P572					—	→ P563
Solenoid valve multi-axis type Network specification	MSEP-C-④-⑤-⑥-0-0	Field network-ready positioner type, allowing up to 8 axes to be connected	256 points							

\* ① indicates I/O type (NP/PN). \* ② indicates number of axes (1 to 8). \* ③ indicates field network specification symbol. \* □ indicates N (NPN specification) or P (PNP specification) symbol.



RCP4-RA5R



Toll Free Phone (877) SERV098  
Toll Free Fax (877) SERV099  
www.electromate.com  
sales@electromate.com

- Slider Type
- Mini
- Standard
- Controller Integrated
- Rod Type
- Mini
- Standard
- Controllers Integrated
- Table/ Arm/ Flat Type
- Mini
- Standard
- Gripper/ Rotary Type
- Linear Servo Type
- Clean-room Type
- Splash-Proof Type
- Pulse Motor
- Servo Motor (24V)
- Servo Motor (200V)
- Linear Servo Motor



# RCP4-RA6R

ROBO Cylinder, Rod Type, Side-mounted Motor, Actuator Width 61mm, 24-V Pulse Motor

**Model Specification Items**

**RCP4** — **RA6R** — **I** — **56P** — [ ] — [ ] — **P3** — [ ] — [ ]

Series — Type — Encoder type — Motor type — Lead — Stroke — Applicable controller — Cable length — Options

I: Incremental    56P: Pulse motor, size 56□    24: 24mm  
16: 16mm    8: 8mm    4: 4mm

50: 50mm  
500: 500mm (50mm pitch increments)

P3: PCON-CA  
MSEP-C

N: None  
P: 1m  
S: 3m  
M: 5m  
X□: Custom length  
R□: Robot cable

See Options below.

\* Be sure to specify either "ML" or "MR" as the motor side-mounted direction.

\* See page Pre-47 for details on the model descriptions.

## Built-in guide mechanism



The "Motor side-mounted to the left (ML)" option is selected for the actuator shown above.

Technical References Appendix P.5



- The maximum payload is the value when operated at 0.3G (0.2G with some models) acceleration. The upper limit of acceleration is 1 G (\*). Note that raising the acceleration causes the payload to drop. (\* The specific value varies depending on the connected controller and actuator lead. For details, refer to "Selection References" on page A-105 and A-107.
- Take note that the maximum payload and maximum speed vary depending on the controller connected to the RCP4. (Refer to the actuator specifications below.)
- All horizontal payloads are values when an external guide is used.
- See page A-71 for details on push motion.

## Correlation Diagrams of Speed and Payload

\* The values of the horizontal specification assume that an external guide is used.

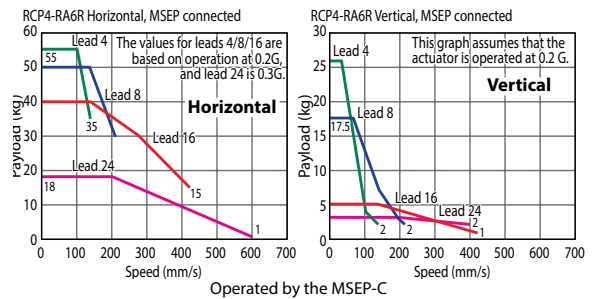
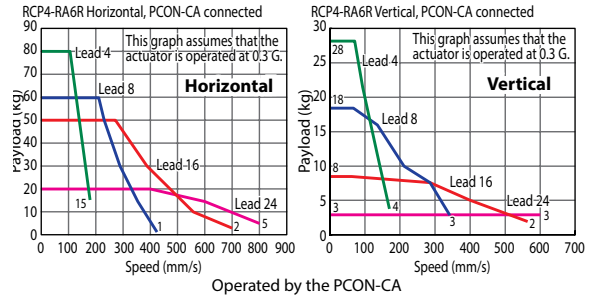

## Actuator Specifications

### Leads and Payloads

Model number	Lead (mm)	Connected controller	Maximum payload		Max. push force (N)	Stroke (mm)
			Horizontal (kg)	Vertical (kg)		
RCP4-RA6R-I-56P-24-①-P3-②-③	24	PCON-CA	20	3	182	50 to 500 (every 50mm)
		MSEP-C	18	3 (*)		
RCP4-RA6R-I-56P-16-①-P3-②-③	16	PCON-CA	50	8	273	
		MSEP-C	40 (*)	5 (*)		
RCP4-RA6R-I-56P-8-①-P3-②-③	8	PCON-CA	60	18	547	
		MSEP-C	50 (*)	17.5 (*)		
RCP4-RA6R-I-56P-4-①-P3-②-③	4	PCON-CA	80	28	1094	
		MSEP-C	55 (*)	26 (*)		

### Stroke and Maximum Speed

Lead (mm)	Connected controller	Stroke (mm)	50~500 (every 50mm)
			Speed (mm/s)
24	PCON-CA	800<600>	
	MSEP-C	600<400>	
16	PCON-CA	560	
	MSEP-C	420	
8	PCON-CA	420<350>	
	MSEP-C	210	
4	PCON-CA	175	
	MSEP-C	140	

Code explanation ① Stroke ② Cable length ③ Options \*See page A-71 for details on push motion.

\*The values of lead 8 apply when acceleration is at 0.1G.

The values in <> apply when the actuator is used vertically.

### ① Stroke

Stroke (mm)	Standard price
50	—
100	—
150	—
200	—
250	—
300	—
350	—
400	—
450	—
500	—

### ③ Options

Name	Option code	Page	Standard Price
Brake (*)	B	→ A-42	—
Optional cable exit direction (top)	CJT	→ A-42	—
Optional cable exit direction (outside)	CJO	→ A-42	—
Optional cable exit direction (bottom)	CJB	→ A-42	—
Flange bracket (*)	FL	→ A-44	—
Motor side-mounted to the left (Standard)	ML	→ A-52	—
Motor side-mounted to the Right	MR	→ A-52	—
Non-motor end specification	NM	→ A-52	—
Scraper	SC	→ A-55	—

\* With brake option at 50 stroke, flange bracket can not be used because flange and motor cover may interfere.

### ② Cable Length

Type	Cable symbol	Standard price
Standard type	P (1m)	—
	S (3m)	—
	M (5m)	—
Special length	X06 (6m) ~ X10 (10m)	—
	X11 (11m) ~ X15 (15m)	—
	X16 (16m) ~ X20 (20m)	—
	R01 (1m) ~ R03 (3m)	—
Robot cable	R04 (4m) ~ R05 (5m)	—
	R06 (6m) ~ R10 (10m)	—
	R11 (11m) ~ R15 (15m)	—
	R16 (16m) ~ R20 (20m)	—

\* See page A-59 for cables for maintenance.

## Actuator Specifications

Item	Description
Drive method	Ball screw, ø12mm, rolled C10
Positioning repeatability (*1)	±0.02mm [±0.03mm]
Lost motion	0.1mm or less
Rod	ø25mm stainless steel pipe
Rod non-rotation precision	±0 deg
Allowable rod load mass	Refer to page 154 and page A-117
Rod tip overhang distance	100mm or less
Ambient operating temperature/humidity	0 to 40°C, 85% RH max. (Non-condensing)

(\*1) The value at lead 24 is shown in [ ].

- Slider Type
- Mini
- Standard
- Controller Integrated
- Rod Type
- Mini
- Standard
- Controllers Integrated
- Table/Arm/Flat Type
- Mini
- Standard
- Gripper/Rotary Type
- Linear Servo Type
- Clean-room Type
- Splash-Proof Type
- Pulse Motor
- Servo Motor (24V)
- Servo Motor (200V)
- Linear Servo Motor

**Dimensional Drawings**

CAD drawings can be downloaded from the website. [www.intelligentactuator.com](http://www.intelligentactuator.com)



- (\*1) Connect the motor-encoder integrated cable here.
- (\*2) During home return, be careful to avoid interference from peripheral objects because the slider travels until the mechanical end.
- (\*3) The orientation of the bolt varies depending on the product.
- (\*4) If the actuator is installed using the front housing and flange, make sure the actuator will not receive any external force.

ME: Mechanical end  
SE: Stroke end

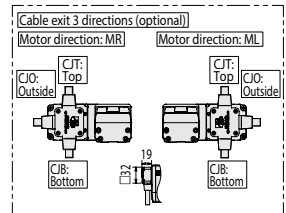
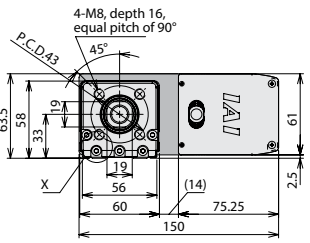
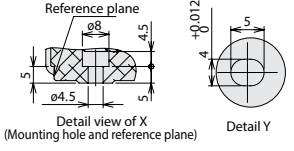

**Dimensions with Flange (Optional) (\*4)**

\*With brake option at 50 stroke, flange bracket can not be used because flange and motor cover may interfere.

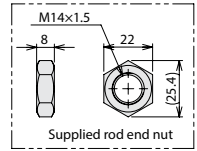
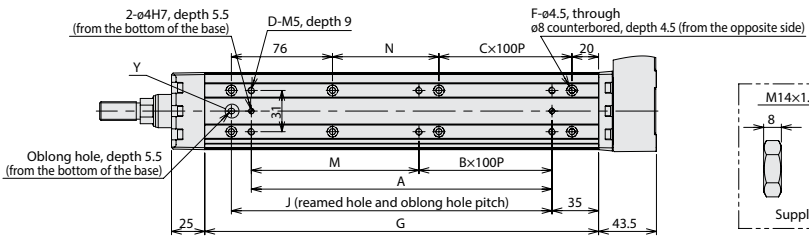
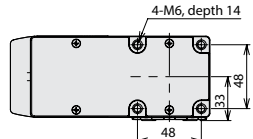
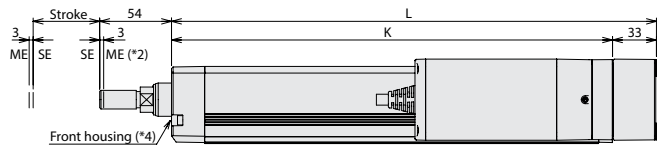
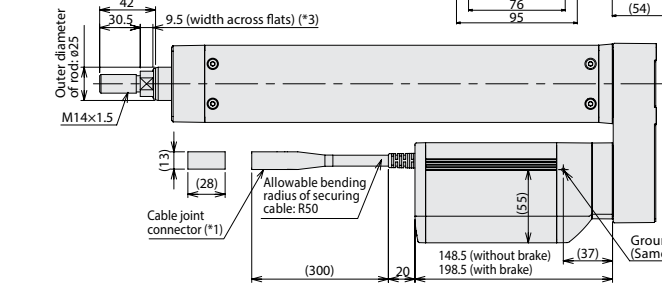
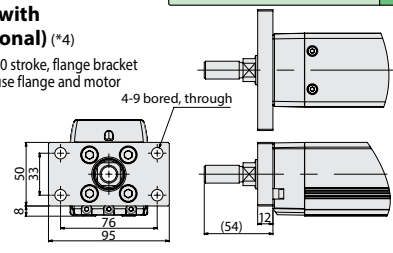

**Rod Deflection of RCP4-RA6R (Reference Values)**

(The graph below plots deflection as measured by installing the actuator vertically and applying a force to the rod from one side.)

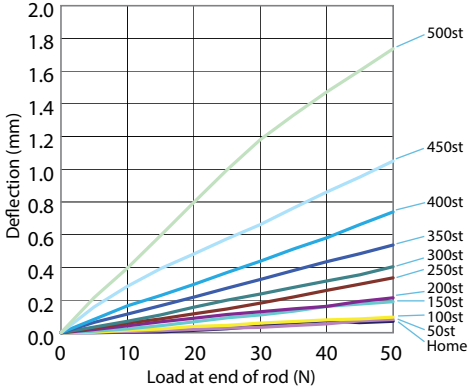

**Dimensions and Mass by Stroke**

Stroke	50	100	150	200	250	300	350	400	450	500
L	214.5	264.5	314.5	364.5	414.5	464.5	514.5	564.5	614.5	664.5
A	76	126	176	226	276	326	376	426	476	526
B	0	0	1	1	2	2	3	3	4	4
C	0	0	0	1	1	2	2	3	3	4
D	4	4	6	6	8	8	10	10	12	12
F	6	6	6	8	8	10	10	2	12	14
G	146	196	246	296	346	396	446	496	546	596
J	91	141	191	241	291	341	391	441	491	541
K	181.5	231.5	281.5	331.5	381.5	431.5	481.5	531.5	581.5	631.5
M	76	126	176	226	276	326	376	426	476	526
N	30	80	130	80	130	80	130	80	130	80
Allowable static load at end of rod (N)	112.7	91.5	76.7	65.7	57.2	50.4	44.8	40.2	36.2	32.7
Allowable dynamic load at end of rod (N)	49.0	37.4	29.9	24.5	20.4	17.1	14.5	12.3	10.3	8.6
Allowable static torque at end of rod (N·m)	11.4	9.3	7.9	6.8	6.0	5.4	4.9	4.5	4.1	3.8
Allowable dynamic torque at end of rod (N·m)	3.9	3.1	2.5	2.1	1.8	1.5	1.3	1.1	1.0	0.8
Weight (kg)	Without brake	3.9	4.2	4.5	4.8	5.1	5.5	5.8	6.1	6.4
	With brake	4.4	4.7	5.0	5.3	5.6	6.0	6.3	6.6	6.9

**Applicable Controllers**

RCP4 series actuators can be operated with the controllers indicated below. Select the type according to your intended application.

Name	External view	Model number	Features	Maximum number of positioning points	Input power	Power supply capacity	Standard price	Reference page
Positioner type High-output specification		PCON-CA-56PI-①-2-0	Equipped with a high-output driver PIO control supported	512 points	DC24V	Refer to P618	—	→ P607
Pulse-train type High-output specification		PCON-CA-56PI-PL-□-2-0	Equipped with a high-output driver Pulse-train input supported	—				
Field network type High-output specification		PCON-CA-56PI-③-0-0	Equipped with a high-output driver Field network supported	768 points				
Solenoid valve multi-axis type PIO specification	MSEP-C-④-①-①-2-0	Positioner type based on PIO control, allowing up to 8 axes to be connected	3 points	Refer to P572				
Solenoid valve multi-axis type Network specification	MSEP-C-④-①-③-0-0	Field network-ready positioner type, allowing up to 8 axes to be connected	256 points					

\*① indicates I/O type (NP/PN). \*② indicates number of axes (1 to 8). \*③ indicates field network specification symbol. \*□ indicates N (NPN specification) or P (PNP specification) symbol.



RCP4-RA6R Sold & Serviced By: **154 ELECTROMATE**  
 Toll Free Phone (877) SERV098  
 Toll Free Fax (877) SERV099  
[www.electromate.com](http://www.electromate.com)  
[sales@electromate.com](mailto:sales@electromate.com)

# RCP3-RA2AC

ROBO Cylinder, Mini Rod Type, Motor Unit Coupled Type, Actuator Width 22mm  
Pulse Motor, Ball Screw Specification/Lead Screw Specification

Model Specification Items	<b>RCP3</b>	<b>RA2AC</b>	<b>I</b>						
	Series	Type	Encoder type	Motor type	Lead	Stroke	Applicable controller	Cable length	Options
			I: Incremental *The Simple absolute encoder is also considered type "I".	20P: Pulse motor, size 20□ Standard type 20SP: Pulse motor, size 20□ High thrust type	4: Ball screw 4mm 2: Ball screw 2mm 1: Ball screw 1mm 4S: Lead screw 4mm 2S: Lead screw 2mm 1S: Lead screw 1mm	25: 25mm 100: 100mm (every 25mm)	P1: PCON-PL/PO/SE PSEL P3: PCON-CA PMEC/PSEP MSEP	N: None P: 1m S: 3m M: 5m X□□: Custom length	B: Brake NM: Non-motor end

\* See page Pre-47 for details on the model descriptions.

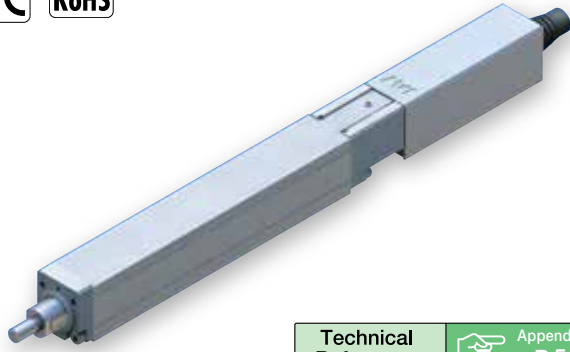

Technical References Appendix P.5

- POINT** Notes on Selection
- (1) The payload is the value when the actuator is operated at an acceleration of 0.3G (0.2G for the lead screw specification, if used vertically). The acceleration limit is the value indicated above.
  - (2) The horizontal payload is the value when used in combination with an external guide. Please note that if an external force is applied to the rod in a direction other than the proper direction the rod travels, the detent may get damaged.
  - (3) The maximum pushing force is the value when the actuator is operated at a speed of 5mm/s. See page A-71 for details on push motion.
  - (4) Service life decreases significantly if used in a dusty environment.

### Correlation Diagrams of Speed and Load Capacity

With the RCP3 series, due to the characteristics of the pulse motor, load capacity decreases as the speed increases. Use the chart below to confirm that the desired speed and load capacity requirements are met.

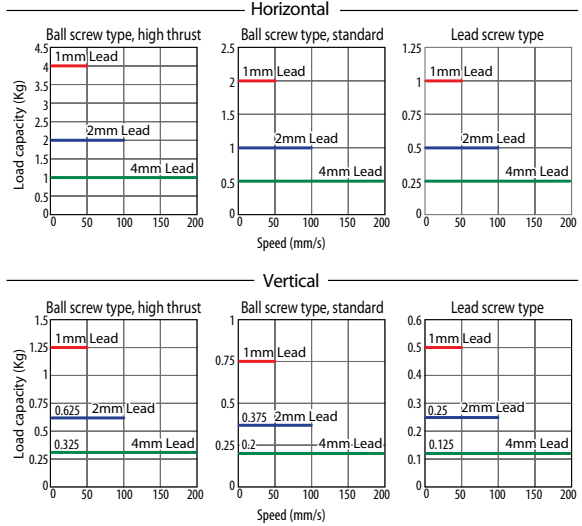

### Actuator Specifications

#### Leads and Payloads

Model number	Motor type	Feed screw	Lead (mm)	Maximum payload		Maximum pushing force (N)	Positioning repeatability (mm)	Stroke (mm)
				Horizontal (kg)	Vertical (kg)			
RCP3-RA2AC-1-20SP-4-①-②-③-④	High thrust	Ball screw	4	1	0.325	See page A-81.	±0.02	25 to 100 (every 25mm)
RCP3-RA2AC-1-20SP-2-①-②-③-④			2	2	0.625			
RCP3-RA2AC-1-20SP-1-①-②-③-④			1	4	1.25			
RCP3-RA2AC-1-20P-4-①-②-③-④			Standard	Ball screw	4			
RCP3-RA2AC-1-20P-2-①-②-③-④	2	1			0.375			
RCP3-RA2AC-1-20P-1-①-②-③-④	1	2			0.75			
RCP3-RA2AC-1-20P-4S-①-②-③-④	Standard	Lead screw			4			
RCP3-RA2AC-1-20P-2S-①-②-③-④			2	0.5	0.25			
RCP3-RA2AC-1-20P-1S-①-②-③-④			1	1	0.5			

#### Stroke and Maximum Speed

Stroke / Lead	25 (mm)		50~100 (mm)	
	25 (mm)	50~100 (mm)	25 (mm)	50~100 (mm)
Ball screw	4	180	200	
	2	100		
	1	50		
Lead screw	4	180	200	
	2	100		
	1	50		

Legend ① Stroke ② Applicable Controller ③ Cable length ④ Options \*See page A-71 for details on push motion. (Unit: mm/s)

#### ① Stroke

① Stroke (mm)	Standard price		
	Feed screw		
	Ball screw		Lead screw
High thrust type	Standard type		
25	—	—	—
50	—	—	—
75	—	—	—
100	—	—	—

#### ④ Options

Name	Option code	Page	Standard Price
Brake	<b>B</b>	→ A-42	—
Non-motor end specification	<b>NM</b>	→ A-52	—

#### ③ Cable Length

Type	Cable symbol	Standard price
Standard type (Robot cable)	<b>P</b> (1m)	—
	<b>S</b> (3m)	—
	<b>M</b> (5m)	—
Special length	<b>X06</b> (6m) ~ <b>X10</b> (10m)	—
	<b>X11</b> (11m) ~ <b>X15</b> (15m)	—
	<b>X16</b> (16m) ~ <b>X20</b> (20m)	—
		—

\* The standard cable for the RCP3 is the robot cable. \* See page A-59 for cables for maintenance.

### Actuator Specifications

Item	Description
Drive method	Ball screw/Lead screw, ø4mm, rolled C10
Lost motion	Ball screw: 0.1mm or less/Lead screw: 0.3mm or less (default value)
Base	Material: Aluminum, white alumite treated
Guide	Slide guide
Ambient operating temperature/humidity	0 to 40°C, 85% RH max. (No condensing)
Service life	Lead screw specification
	Ball screw specification
	Horizontal: 10 million cycles, Vertical: 5 million cycles 5,000km or 50 million cycles

Dimensional Drawings

CAD drawings can be downloaded from the website. [www.intelligentactuator.com](http://www.intelligentactuator.com)

For Special Orders Appendix P.15



- (\*1) Connect the motor-encoder integrated cable here.
- (\*2) During home return, be careful to avoid interference from peripheral objects because the slider travels until the mechanical end.
- (\*3) The orientation of the bolt varies depending on the product.

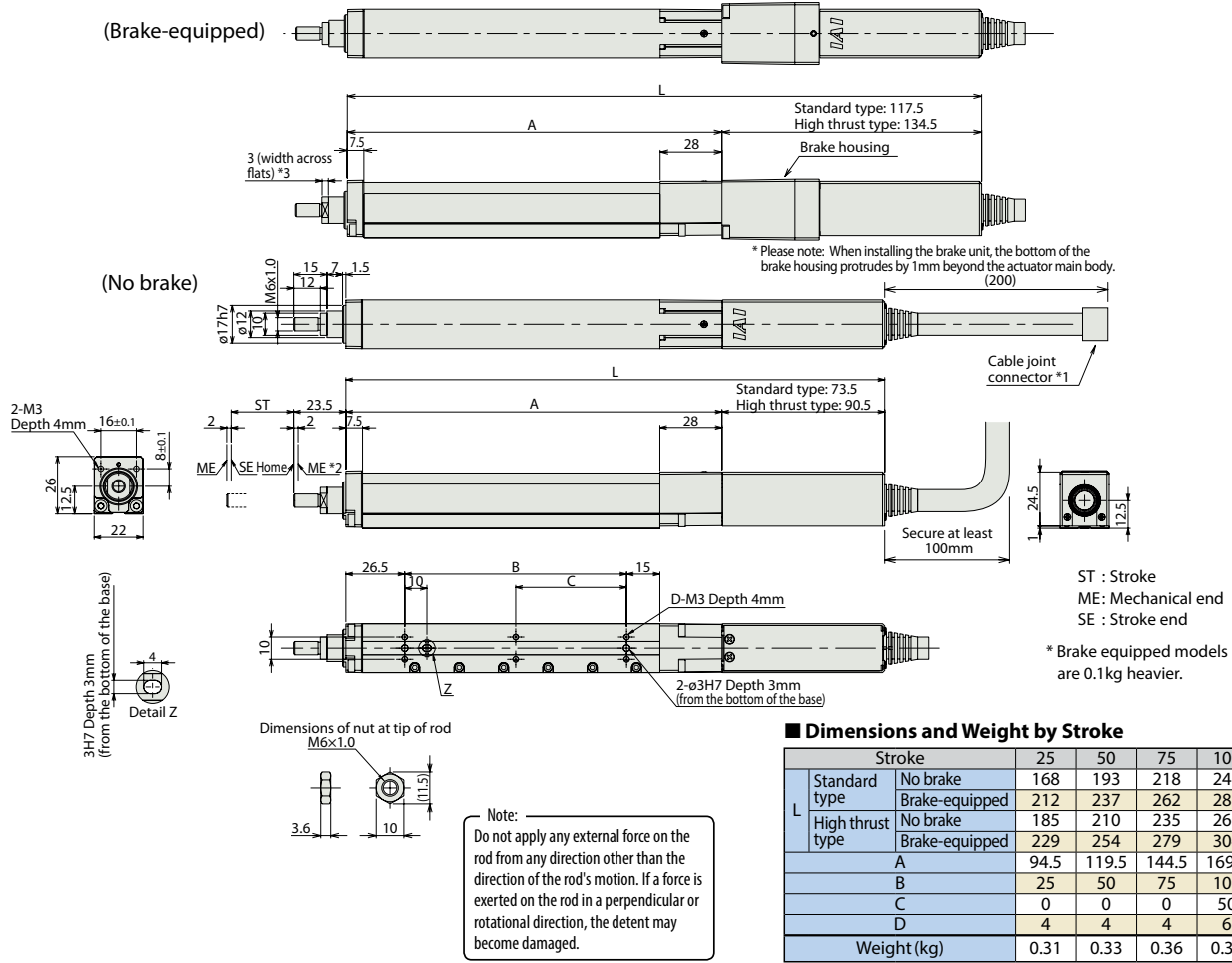

Note: Do not apply any external force on the rod from any direction other than the direction of the rod's motion. If a force is exerted on the rod in a perpendicular or rotational direction, the detent may become damaged.

Applicable Controllers

RCP3 series actuators can be operated with the controllers indicated below. Select the type according to your intended application.

Name	External view	Model number	Features	Maximum number of positioning points	Input power	Power-supply capacity	Standard price	Reference page
Solenoid Valve Type		PMEC-C-20SPI-①-2-② PMEC-C-20PI-①-2-②	Easy-to-use controller, even for beginners	3 points	AC100V AC200V	Refer to P541	—	→ P537
		PSEP-C-20SPI-①-2-0 PSEP-C-20PI-①-2-0	Simple controller operable with the same signal as a solenoid valve					→ P547
Solenoid valve multi-axis type PIO specification		MSEP-C-③-④-①-2-0	Positioner type based on PIO control, allowing up to 8 axes to be connected	256 points	DC24V	Refer to P572	—	→ P563
Solenoid valve multi-axis type Network specification		MSEP-C-③-④-④-0-0	Field network-ready positioner type, allowing up to 8 axes to be connected					→ P607
Positioner type High-output specification		PCON-CA-20SPI-①-2-0 PCON-CA-20PI-①-2-0	Equipped with a high-output driver Positioner type based on PIO control	512 points	DC24V	Refer to P618	—	→ P623
Pulse-train type High-output specification		PCON-CA-20SPI-PL□-2-0 PCON-CA-20PI-PL□-2-0	Equipped with a high-output driver Pulse-train input type	(—)				
Field network type High-output specification		PCON-CA-20SPI-④-0-0 PCON-CA-20PI-④-0-0	Equipped with a high-output driver Supporting 7 major field networks	768 points				
Pulse Train Input Type (Differential Line Driver)		PCON-PL-20SPI-①-2-0 PCON-PL-20PI-①-2-0	Pulse train input type with differential line driver support	(—)	DC24V	Refer to P628	—	→ P665
Pulse Train Input Type (Open Collector)		PCON-PO-20SPI-①-2-0 PCON-PO-20PI-①-2-0	Pulse train input type with open collector support					
Serial Communication Type		PCON-SE-20SPI-N-0-0 PCON-SE-20PI-N-0-0	Dedicated Serial Communication	64 points	DC24V	Refer to P671	—	→ P665
Program Control Type		PSEL-CS-1-20SPI-①-2-0 PSEL-CS-1-20PI-①-2-0	Programmed operation is possible. Can operate up to 2 axes	1,500 points	DC24V	Refer to P671	—	→ P665

\* This is for the single-axis PSEL. \* ① indicates I/O type (NP/PN). \* ② indicates power supply voltage (1: 100V / 2: 100~240V). \* ③ indicates number of axes (1 to 8). \* ④ indicates field network specification symbol. \* □ indicates N (NPN specification) or P (PNP specification) symbol.



- Slider Type
- Mini
- Standard
- Controller Integrated
- Rod Type
- Mini
- Standard
- Controllers Integrated
- Table/ Arm/ Flat Type
- Mini
- Standard
- Gripper/ Rotary Type
- Linear Servo Type
- Clean-room Type
- Splash-Proof Type
- Pulse Motor
- Servo Motor (24V)
- Servo Motor (200V)
- Linear Servo Motor

# RCP3-RA2BC

ROBO Cylinder, Mini Rod Type, Motor Unit Coupled Type, Actuator Width 28mm  
Pulse Motor, Ball Screw Specification/Lead Screw Specification

Model Specification Items	<b>RCP3</b>	<b>RA2BC</b>	<b>I</b>						
	Series	Type	Encoder type	Motor type	Lead	Stroke	Applicable controller	Cable length	Options
			I: Incremental *The Simple absolute encoder is also considered type "I".	20P: Pulse motor, size 20□ Standard type 20SP: Pulse motor, size 20□ High thrust type	6: Ball screw 6mm 4: Ball screw 4mm 2: Ball screw 2mm 1: Ball screw 1mm 6S: Lead screw 6mm 4S: Lead screw 4mm 2S: Lead screw 2mm	25: 25mm 150: 150mm (every 25mm)	P1: PCON-PL/PO/SE PSEL P3: PCON-CA PMEC/PSEP MSEP	N: None P: 1m S: 3m M: 5m X□□: Custom length	B: Brake NM: Non-motor end

\* See page Pre-47 for details on the model descriptions.

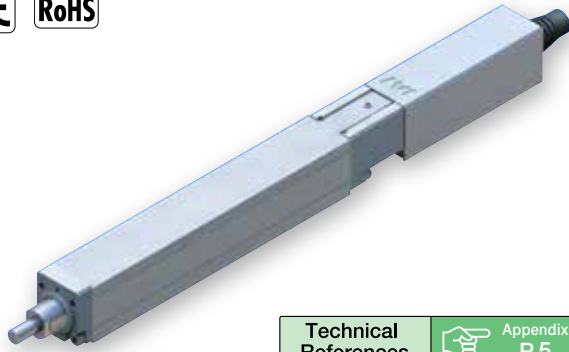

Technical References Appendix P.5

- POINT**  
Notes on Selection
- The payload is the value when the actuator is operated at an acceleration of 0.3G (0.2G for the lead screw specification, if used vertically). The acceleration limit is the value indicated above.
  - The horizontal payload is the value when used in combination with an external guide. Please note that if an external force is applied to the rod in a direction other than the proper direction the rod travels, the detent may get damaged.
  - The maximum pushing force is the value when the actuator is operated at a speed of 5mm/s. See page A-71 for details on push motion.
  - Service life decreases significantly if used in a dusty environment.

### Correlation Diagrams of Speed and Load Capacity

With the RCP3 series, due to the characteristics of the pulse motor, load capacity decreases as the speed increases. Use the chart below to confirm that the desired speed and load capacity requirements are met.

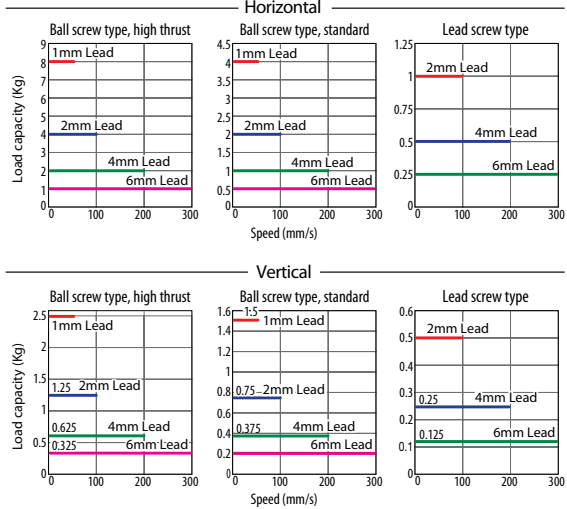

### Actuator Specifications

#### Leads and Payloads

Model number	Motor type	Feed screw	Lead (mm)	Maximum payload		Maximum pushing force (N)	Positioning repeatability (mm)	Stroke (mm)
				Horizontal (kg)	Vertical (kg)			
RCP3-RA2BC-1-20SP-6-①-②-③-④	High thrust	Ball screw	6	1	0.325	See page A-81.	±0.02	25 to 150 (every 25mm)
RCP3-RA2BC-1-20SP-4-①-②-③-④			4	2	0.625			
RCP3-RA2BC-1-20SP-2-①-②-③-④			2	4	1.25			
RCP3-RA2BC-1-20SP-1-①-②-③-④			1	8	2.5			
RCP3-RA2BC-1-20P-6-①-②-③-④	Standard	Ball screw	6	0.5	0.2			
RCP3-RA2BC-1-20P-4-①-②-③-④			4	1	0.375			
RCP3-RA2BC-1-20P-2-①-②-③-④			2	2	0.75			
RCP3-RA2BC-1-20P-1-①-②-③-④			1	4	1.5			
RCP3-RA2BC-1-20P-6S-①-②-③-④	Standard	Lead screw	6	0.25	0.125			
RCP3-RA2BC-1-20P-4S-①-②-③-④			4	0.5	0.25			
RCP3-RA2BC-1-20P-2S-①-②-③-④			2	1	0.5			

#### Stroke and Maximum Speed

Stroke	Maximum Speed		
	25 (mm)	50 (mm)	75~150 (mm)
6	180	280	300
4	180	200	
2	100		
1	50		
6	180	280	300
4	180	200	
2	100		

Legend ① Stroke ② Applicable Controller ③ Cable length ④ Options \*See page A-71 for details on push motion.

(Unit: mm/s)

#### ① Stroke

① Stroke (mm)	Standard price		
	Feed screw		
	Ball screw		Lead screw
High thrust type	Standard type		
25	—	—	—
50	—	—	—
75	—	—	—
100	—	—	—
125	—	—	—
150	—	—	—

#### ④ Options

Name	Option code	Page	Standard Price
Brake	<b>B</b>	→ A-42	—
Non-motor end specification	<b>NM</b>	→ A-52	—

#### ③ Cable Length

Type	Cable symbol	Standard price
Standard type (Robot cable)	<b>P</b> (1m)	—
	<b>S</b> (3m)	—
	<b>M</b> (5m)	—
Special length	<b>X06</b> (6m) ~ <b>X10</b> (10m)	—
	<b>X11</b> (11m) ~ <b>X15</b> (15m)	—
	<b>X16</b> (16m) ~ <b>X20</b> (20m)	—
		—

\* The standard cable for the RCP3 is the robot cable.  
\* See page A-59 for cables for maintenance.

#### Actuator Specifications

Item	Description
Drive method	Ball screw/Lead screw, ø6mm, rolled C10
Lost motion	Ball screw: 0.1mm or less/Lead screw: 0.3mm or less (default value)
Base	Material: Aluminum, white alumite treated
Guide	Slide guide
Ambient operating temperature/humidity	0 to 40°C, 85% RH max. (No condensing)
Service life	Lead screw specification
	Ball screw specification

Dimensional Drawings

CAD drawings can be downloaded from the website. [www.intelligentactuator.com](http://www.intelligentactuator.com)

For Special Orders Appendix P.15



- (\*1) Connect the motor-encoder integrated cable here.
- (\*2) During home return, be careful to avoid interference from peripheral objects because the slider travels until the mechanical end.
- (\*3) The orientation of the bolt varies depending on the product.

(Brake-equipped)

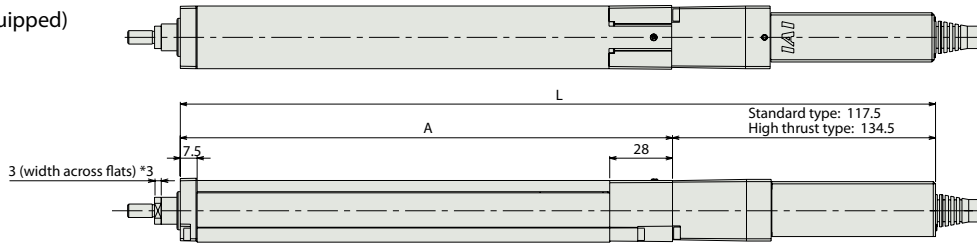

(No brake)

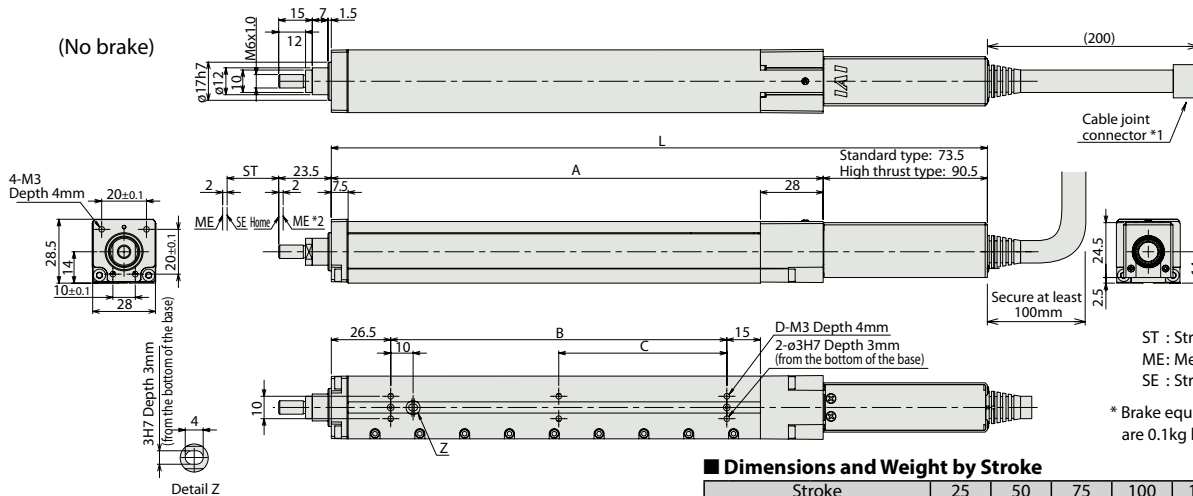

ST : Stroke  
ME : Mechanical end  
SE : Stroke end  
\* Brake equipped models are 0.1kg heavier.

Dimensions and Weight by Stroke

Stroke		25	50	75	100	125	150
L	Standard type No brake	168	193	218	243	268	293
	Standard type Brake-equipped	212	237	262	287	312	337
	High thrust type No brake	185	210	235	260	285	310
	High thrust type Brake-equipped	229	254	279	304	329	354
A		94.5	119.5	144.5	169.5	194.5	219.5
B		25	50	75	100	125	150
C		0	0	0	50	62.5	75
D		4	4	4	6	6	6
Weight (kg)		0.36	0.39	0.42	0.45	0.48	0.51

Note:  
Do not apply any external force on the rod from any direction other than the direction of the rod's motion. If a force is exerted on the rod in a perpendicular or rotational direction, the detent may become damaged.

Dimensions of nut at tip of rod

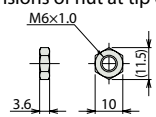

Applicable Controllers

RCP3 series actuators can be operated with the controllers indicated below. Select the type according to your intended application.

Name	External view	Model number	Features	Maximum number of positioning points	Input power	Power-supply capacity	Standard price	Reference page
Solenoid Valve Type		PMEC-C-20SPI-①-2-② PMEC-C-20PI-①-2-②	Easy-to-use controller, even for beginners	3 points	AC100V AC200V	Refer to P541	—	→ P537
		PSEP-C-20SPI-①-2-0 PSEP-C-20PI-①-2-0	Simple controller operable with the same signal as a solenoid valve					Refer to P555
Solenoid valve multi-axis type PIO specification		MSEP-C-③-④-①-2-0	Positioner type based on PIO control, allowing up to 8 axes to be connected	256 points	DC24V	Refer to P572	—	→ P563
Solenoid valve multi-axis type Network specification		MSEP-C-③-④-④-0-0	Field network-ready positioner type, allowing up to 8 axes to be connected					Refer to P618
Positioner type High-output specification		PCON-CA-20SPI-①-2-0 PCON-CA-20PI-①-2-0	Equipped with a high-output driver Positioner type based on PIO control	512 points	DC24V	Refer to P618	—	→ P607
Pulse-train type High-output specification		PCON-CA-20SPI-PL□-2-0 PCON-CA-20PI-PL□-2-0	Equipped with a high-output driver Pulse-train input type	(—)				
Field network type High-output specification		PCON-CA-20SPI-④-0-0 PCON-CA-20PI-④-0-0	Equipped with a high-output driver Supporting 7 major field networks	768 points				
Pulse Train Input Type (Differential Line Driver)		PCON-PL-20SPI-①-2-0 PCON-PL-20PI-①-2-0	Pulse train input type with differential line driver support	(—)	DC24V	Refer to P628	—	→ P623
Pulse Train Input Type (Open Collector)		PCON-PO-20SPI-①-2-0 PCON-PO-20PI-①-2-0	Pulse train input type with open collector support					
Serial Communication Type		PCON-SE-20SPI-N-0-0 PCON-SE-20PI-N-0-0	Dedicated Serial Communication	64 points	DC24V	Refer to P671	—	→ P665
Program Control Type		PSEL-CS-1-20SPI-①-2-0 PSEL-CS-1-20PI-①-2-0	Programmed operation is possible. Can operate up to 2 axes	1500 points	DC24V	Refer to P671	—	→ P665

\* This is for the single-axis PSEL. \* ① indicates I/O type (NP/PN). \* ② indicates power supply voltage (1: 100V / 2: 100~240V). \* ③ indicates number of axes (1 to 8). \* ④ indicates field network specification symbol. \* □ indicates N (NPN specification) or P (PNP specification) symbol.



- Slider Type
- Mini
- Standard
- Controller Integrated
- Rod Type
- Mini
- Standard
- Controllers Integrated
- Table/ Arm/ Flat Type
- Mini
- Standard
- Gripper/ Rotary Type
- Linear Servo Type
- Clean-room Type
- Splash-Proof Type
- Pulse Motor
- Servo Motor (24V)
- Servo Motor (200V)
- Linear Servo Motor

# RCP3-RA2AR

ROBO Cylinder, Mini Rod Type, Side-mounted Motor Type, Actuator Width 22mm  
Pulse Motor, Ball Screw Specification/Lead Screw Specification

Model Specification Items	<b>RCP3</b>	<b>RA2AR</b>	<b>I</b>						
	Series	Type	Encoder type	Motor type	Lead	Stroke	Applicable controller	Cable length	Options
			I: Incremental *The Simple absolute encoder is also considered type "I".	20P: Pulse motor, size 20□ Standard type 20SP: Pulse motor, size 20□ High thrust type	4: Ball screw 4mm 2: Ball screw 2mm 1: Ball screw 1mm 4S: Lead screw 4mm 2S: Lead screw 2mm 1S: Lead screw 1mm	25: 25mm 100: 100mm (every 25mm)	P1: PCON-PL/PO/SE PSEL P3: PCON-CA PMEC/PSEP MSEP	N: None P: 1m S: 3m M: 5m X□□: Custom length	See Options below.  * Be sure to specify either "ML" or "MR" as the motor side-mounted direction.

\* See page Pre-47 for details on the model descriptions.

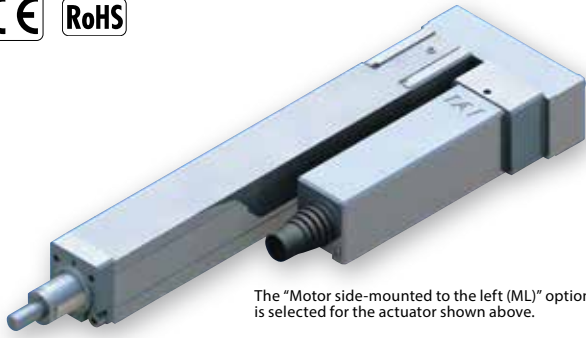

The "Motor side-mounted to the left (ML)" option is selected for the actuator shown above.

Technical References Appendix P.5

- POINT** Notes on Selection
- (1) The payload is the value when the actuator is operated at an acceleration of 0.3G (0.2G for the lead screw specification, if used vertically). The acceleration limit is the value indicated above.
  - (2) The horizontal payload is the value when used in combination with an external guide. Please note that if an external force is applied to the rod in a direction other than the proper direction the rod travels, the detent may get damaged.
  - (3) The maximum pushing force is the value when the actuator is operated at a speed of 5mm/s. See page A-71 for details on push motion.
  - (4) Service life decreases significantly if used in a dusty environment.

### Correlation Diagrams of Speed and Load Capacity

With the RCP3 series, due to the characteristics of the pulse motor, load capacity decreases as the speed increases. Use the chart below to confirm that the desired speed and load capacity requirements are met.

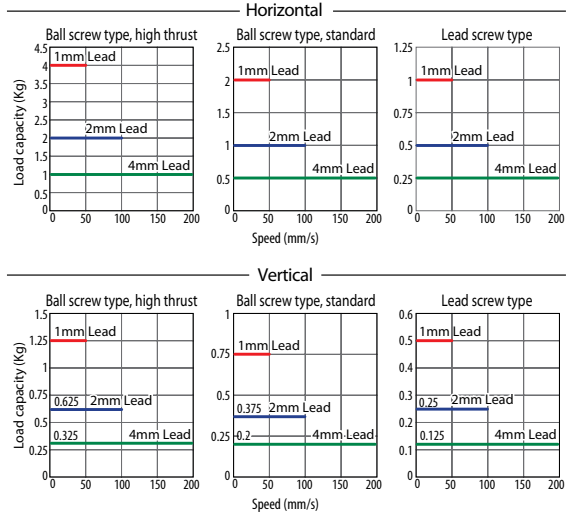

### Actuator Specifications

#### Leads and Payloads

Model number	Motor type	Feed screw	Lead (mm)	Maximum payload		Maximum pushing force (N)	Positioning repeatability (mm)	Stroke (mm)			
				Horizontal (kg)	Vertical (kg)						
RCP3-RA2AR-1-20SP-4-①-②-③-④	High thrust	Ball screw	4	1	0.325	See page A-81.	±0.02	25 to 100 (every 25mm)			
RCP3-RA2AR-1-20SP-2-①-②-③-④			2	2	0.625						
RCP3-RA2AR-1-20SP-1-①-②-③-④			1	4	1.25						
RCP3-RA2AR-1-20P-4-①-②-③-④	Standard	Ball screw	4	0.5	0.2						
RCP3-RA2AR-1-20P-2-①-②-③-④			2	1	0.375						
RCP3-RA2AR-1-20P-1-①-②-③-④			1	2	0.75						
RCP3-RA2AR-1-20P-4S-①-②-③-④	Standard	Lead screw	4	0.25	0.125				±0.05		
RCP3-RA2AR-1-20P-2S-①-②-③-④			2	0.5	0.25						
RCP3-RA2AR-1-20P-1S-①-②-③-④			1	1	0.5						

Legend ① Stroke ② Applicable Controller ③ Cable length ④ Options \*See page A-71 for details on push motion.

#### Stroke and Maximum Speed

Stroke / Lead	25 (mm)		50~100 (mm)	
	25 (mm)	50~100 (mm)	25 (mm)	50~100 (mm)
Ball screw	4	180	200	
	2	100		
	1	50		
Lead screw	4	180	200	
	2	100		
	1	50		

(Unit: mm/s)

#### ① Stroke

① Stroke (mm)	Standard price		
	Feed screw		
	Ball screw		Lead screw
High thrust type	Standard type		
25	—	—	—
50	—	—	—
75	—	—	—
100	—	—	—

#### ③ Cable Length

Type	Cable symbol	Standard price
Standard type	P (1m)	—
	S (3m)	—
	M (5m)	—
Special length	X06 (6m) ~ X10 (10m)	—
	X11 (11m) ~ X15 (15m)	—
	X16 (16m) ~ X20 (20m)	—
		—

\* The standard cable for the RCP3 is the robot cable.  
\* See page A-59 for cables for maintenance.

#### ④ Options

Name	Option code	Page	Standard Price
Brake	B	→ A-42	—
Side-mounted motor to the left (standard)	ML	→ A-52	—
Side-mounted motor to the right	MR	→ A-52	—
Non-motor end specification	NM	→ A-52	—

#### Actuator Specifications

Item	Description
Drive method	Ball screw/Lead screw, ø4mm, rolled C10
Lost motion	Ball screw: 0.1mm or less/Lead screw: 0.3mm or less (default value)
Base	Material: Aluminum, white alumite treated
Guide	Slide guide
Ambient operating temperature/humidity	0 to 40°C, 85% RH max. (No condensing)
Service life	Lead screw specification
	Ball screw specification

Dimensional Drawings

CAD drawings can be downloaded from the website.

www.intelligentactuator.com

\* The drawing below shows the specification of the motor side-mounted to the left.

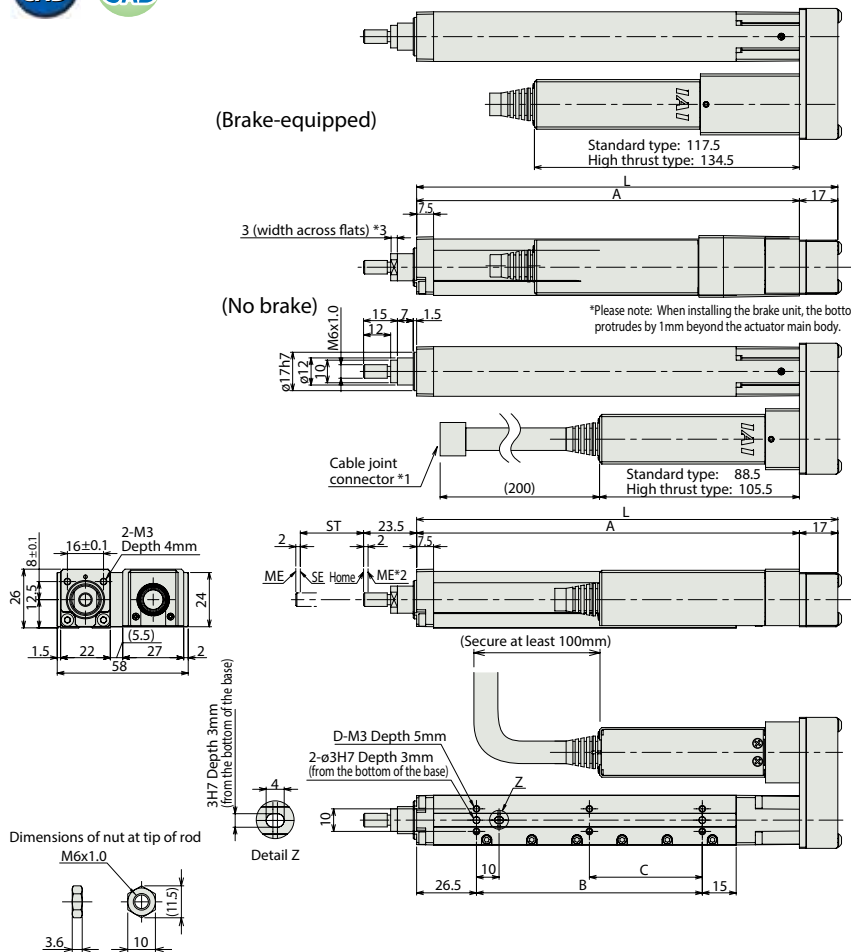

For Special Orders Appendix P.15

- (\*1) Connect the motor-encoder integrated cable here.
- (\*2) During home return, be careful to avoid interference from peripheral objects because the slider travels until the mechanical end.
- (\*3) The orientation of the bolt varies depending on the product.

Note:  
Do not apply any external force on the rod from any direction other than the direction of the rod's motion. If a force is exerted on the rod in a perpendicular or rotational direction, the detent may become damaged.



ST : Stroke  
ME : Mechanical end  
SE : Stroke end

\* Brake equipped models are 0.1kg heavier.

**■ Dimensions and Weight by Stroke**

Stroke	25	50	75	100
L	111.5	136.5	161.5	186.5
A	94.5	119.5	144.5	169.5
B	25	50	75	100
C	0	0	0	50
D	4	4	4	6
Weight (kg)	0.34	0.36	0.39	0.4

② Applicable Controllers

RCP3 series actuators can be operated with the controllers indicated below. Select the type according to your intended application.

Name	External view	Model number	Features	Maximum number of positioning points	Input power	Power-supply capacity	Standard price	Reference page
Solenoid Valve Type		PMEC-C-20SPI-①-2-② PMEC-C-20PI-①-2-②	Easy-to-use controller, even for beginners	3 points	AC100V AC200V	Refer to P541	—	→ P537
		PSEP-C-20SPI-①-2-0 PSEP-C-20PI-①-2-0	Simple controller operable with the same signal as a solenoid valve					→ P547
Solenoid valve multi-axis type PIO specification		MSEP-C-③-④-①-2-0	Positioner type based on PIO control, allowing up to 8 axes to be connected	256 points	DC24V	Refer to P572	—	→ P563
Solenoid valve multi-axis type Network specification		MSEP-C-③-④-⑤-0-0	Field network-ready positioner type, allowing up to 8 axes to be connected					→ P607
Positioner type High-output specification		PCON-CA-20SPI-①-2-0 PCON-CA-20PI-①-2-0	Equipped with a high-output driver Positioner type based on PIO control	512 points	DC24V	Refer to P618	—	→ P623
Pulse-train type High-output specification		PCON-CA-20SPI-①-2-0 PCON-CA-20PI-PL-①-2-0	Equipped with a high-output driver Pulse-train input type	(—)				
Field network type High-output specification		PCON-CA-20SPI-⑤-0-0 PCON-CA-20PI-⑤-0-0	Equipped with a high-output driver Supporting 7 major field networks	768 points				
Pulse Train Input Type (Differential Line Driver)		PCON-PL-20SPI-①-2-0 PCON-PL-20PI-①-2-0	Pulse train input type with differential line driver support	(—)	DC24V	Refer to P628	—	→ P623
Pulse Train Input Type (Open Collector)		PCON-PO-20SPI-①-2-0 PCON-PO-20PI-①-2-0	Pulse train input type with open collector support					
Serial Communication Type		PCON-SE-20SPI-N-0-0 PCON-SE-20PI-N-0-0	Dedicated Serial Communication	64 points	DC24V	Refer to P671	—	→ P665
Program Control Type		PSEL-CS-1-20SPI-①-2-0 PSEL-CS-1-20PI-①-2-0	Programmed operation is possible. Can operate up to 2 axes	1500 points	DC24V	Refer to P671	—	→ P665

\* This is for the single-axis PSEL. \* ① indicates I/O type (NP/PN). \* ② indicates power supply voltage (1: 100V / 2: 100~240V). \* ③ indicates number of axes (1 to 8). \* ④ indicates field network specification symbol. \* ⑤ indicates N (NPN specification) or P (PNP specification) symbol.

- Slider Type
- Mini
- Standard
- Controller Integrated
- Rod Type
- Mini
- Standard
- Controllers Integrated
- Table/ Arm/ Flat Type
- Mini
- Standard
- Gripper/ Rotary Type
- Linear Servo Type
- Clean-room Type
- Splash-Proof Type
- Pulse Motor
- Servo Motor (24V)
- Servo Motor (200V)
- Linear Servo Motor



# RCP3-RA2BR

ROBO Cylinder, Mini Rod Type, Side-mounted Motor Type, Actuator Width 28mm  
Pulse Motor, Ball Screw Specification/Lead Screw Specification

Model Specification Items	<b>RCP3</b>	<b>RA2BR</b>	<b>I</b>							
	Series	Type	Encoder type	Motor type	Lead	Stroke	Applicable controller	Cable length	Options	
			I: Incremental *The Simple absolute encoder is also considered type "I".	20P: Pulse motor, size 20□ Standard type 20SP: Pulse motor, size 20□ High thrust type	6: Ball screw 6mm 4: Ball screw 4mm 2: Ball screw 2mm 1: Ball screw 1mm 6S: Lead screw 6mm 4S: Lead screw 4mm 2S: Lead screw 2mm	25: 25mm 150: 150mm (every 25mm)	P1: PCON-PL/PO/SE PSEL P3: PCON-CA PMEC/PSEP MSEP	N: None P: 1m S: 3m M: 5m X□□: Custom length	See Options below.  * Be sure to specify either "ML" or "MR" as the motor side-mounted direction.	

\* See page Pre-47 for details on the model descriptions.



The "Motor side-mounted to the left (ML)" option is selected for the actuator shown above.

Technical References Appendix P.5

- POINT** Notes on Selection
- (1) The payload is the value when the actuator is operated at an acceleration of 0.3G (0.2G for the lead screw specification, if used vertically). The acceleration limit is the value indicated above.
  - (2) The horizontal payload is the value when used in combination with an external guide. Please note that if an external force is applied to the rod in a direction other than the proper direction the rod travels, the detent may get damaged.
  - (3) The maximum pushing force is the value when the actuator is operated at a speed of 5mm/s. See page A-71 for details on push motion.
  - (4) Service life decreases significantly if used in a dusty environment.

### Correlation Diagrams of Speed and Load Capacity

With the RCP3 series, due to the characteristics of the pulse motor, load capacity decreases as the speed increases. Use the chart below to confirm that the desired speed and load capacity requirements are met.

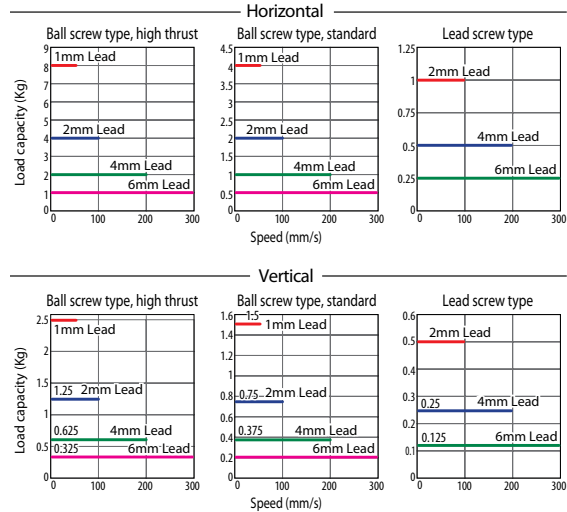

### Actuator Specifications

#### Leads and Payloads

Model number	Motor type	Feed screw	Lead (mm)	Maximum payload		Maximum pushing force (N)	Positioning repeatability (mm)	Stroke (mm)
				Horizontal (kg)	Vertical (kg)			
RCP3-RA2BR-1-20SP-6-①-②-③-④	High thrust	Ball screw	6	1	0.325	See page A-81.	±0.02	25 to 150 (every 25mm)
RCP3-RA2BR-1-20SP-4-①-②-③-④			4	2	0.625			
RCP3-RA2BR-1-20SP-2-①-②-③-④			2	4	1.25			
RCP3-RA2BR-1-20SP-1-①-②-③-④			1	8	2.5			
RCP3-RA2BR-1-20P-6-①-②-③-④	Standard	Ball screw	6	0.5	0.2			
RCP3-RA2BR-1-20P-4-①-②-③-④			4	1	0.375			
RCP3-RA2BR-1-20P-2-①-②-③-④			2	2	0.75			
RCP3-RA2BR-1-20P-1-①-②-③-④			1	4	1.5			
RCP3-RA2BR-1-20P-6S-①-②-③-④	Standard	Lead screw	6	0.25	0.125			
RCP3-RA2BR-1-20P-4S-①-②-③-④			4	0.5	0.25			
RCP3-RA2BR-1-20P-2S-①-②-③-④			2	1	0.5			

#### Stroke and Maximum Speed

Lead	Stroke	25 (mm)	50 (mm)	75~150 (mm)
		Ball screw	6	180
Lead screw	4	180	200	
	2	100		
	1	50		
Ball screw	6	180	280	300
	4	180	200	
	2	100		

Code explanation ① Stroke ② Applicable Controller ③ Cable length ④ Options \*See page A-71 for details on push motion. (Unit: mm/s)

#### ① Stroke

① Stroke (mm)	Standard price		
	Feed screw		
	Ball screw		Lead screw
High thrust type	Standard type		
25	—	—	—
50	—	—	—
75	—	—	—
100	—	—	—
125	—	—	—
150	—	—	—

#### ④ Options

Name	Option code	Page	Standard Price
Brake	<b>B</b>	→ A-42	—
Side-mounted motor to the left (standard)	<b>ML</b>	→ A-52	—
Side-mounted motor to the right	<b>MR</b>	→ A-52	—
Non-pend end specification	<b>NM</b>	→ A-52	—

#### ③ Cable Length

Type	Cable symbol	Standard price
Standard type	<b>P</b> (1m)	—
	<b>S</b> (3m)	—
	<b>M</b> (5m)	—
Special length	<b>X06</b> (6m) ~ <b>X10</b> (10m)	—
	<b>X11</b> (11m) ~ <b>X15</b> (15m)	—
	<b>X16</b> (16m) ~ <b>X20</b> (20m)	—

\* The standard cable for the RCP3 is the robot cable.  
\* See page A-59 for cables for maintenance.

#### Actuator Specifications

Item	Description
Drive method	Ball screw/Lead screw, ø6mm, rolled C10
Lost motion	Ball screw: 0.1mm or less/Lead screw: 0.3mm or less (default value)
Base	Material: Aluminum, white alumite treated
Guide	Slide guide
Ambient operating temperature/humidity	0 to 40°C, 85% RH max. (No condensing)
Service life	Lead screw specification
	Ball screw specification



# RCP2-RA2C

ROBO Cylinder, Rod Type, Actuator Width 25mm, Pulse Motor, Straight Type

Model Specification Items	<b>RCP2</b>	<b>RA2C</b>	<b>I</b>	<b>20P</b>	<b>1</b>				
	Series	Type	Encoder type	Motor type	Lead	Stroke	Applicable controller	Cable length	Options
			I: Incremental *The Simple absolute encoder is also considered type "I".	20P: Pulse motor, 20□ size	1: 1mm	25: 25mm ? 100: 100mm (25mm pitch increments)	P1: PCON-PL/PO/SE PSEL P3: PCON-CA PMEC/PSEP MSEP	N: None P: 1m S: 3m M: 5m X□□: Custom length X□□: Robot cable	See Options below.

\* See page Pre-47 for details on the model descriptions.

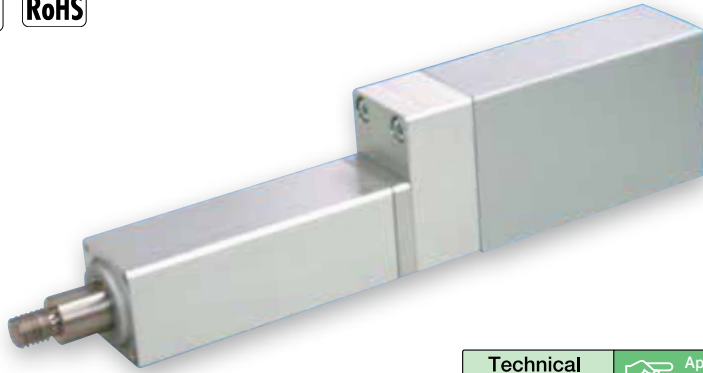

Technical References Appendix P.5



- Since the RCP2 series use a pulse motor, the load capacity decreases at high speeds. Check in the Speed vs. Load Capacity graph to see if your desired speed and load capacity are supported.
- The load capacity is based on operation at an acceleration of 0.05G. 0.05G is the upper limit of the acceleration. In addition, the horizontal load capacity is based on the use of an external guide. If an external force is exerted on the rod from a direction other than the motion of the rod, the detent may become damaged.
- See page A-71 for details on push motion.

### Speed vs. Load Capacity

Due to the characteristics of the pulse motor, the RCP2 series' load capacity decreases at high speeds. In the table below, check if your desired speed and load capacity are supported.

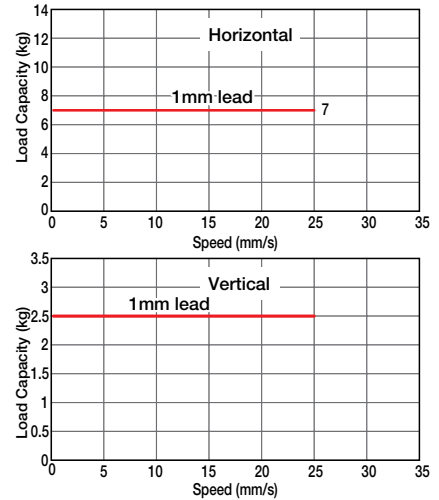

### Actuator Specifications

#### Lead and Payloads

Model number	Lead (mm)	Maximum payload		Maximum pushing force (N)	Stroke (mm)
		Horizontal (kg)	Vertical (kg)		
RCP2-RA2C-I-20P-1-①-②-③-④	1	7	2.5	100	25 to 100 (every 25mm)

#### Stroke and Maximum Speed

Stroke / Lead	25~100 (every 50mm)	
	Stroke	Lead
1	25	25

Code explanation ① Stroke ② Applicable Controller ③ Cable length ④ Options \*See page A-71 for details on push motion. (Unit: mm/s)

#### ① Stroke

① Stroke (mm)	Standard price
25	—
50	—
75	—
100	—

#### ③ Cable Length

Type	Cable symbol	Standard price
Standard type	P (1m)	—
	S (3m)	—
	M (5m)	—
Special length	X06 (6m) ~ X10 (10m)	—
	X11 (11m) ~ X15 (15m)	—
	X16 (16m) ~ X20 (20m)	—
	R01 (1m) ~ R03 (3m)	—
Robot cable	R04 (4m) ~ R05 (5m)	—
	R06 (6m) ~ R10 (10m)	—
	R11 (11m) ~ R15 (15m)	—
	R16 (16m) ~ R20 (20m)	—

\* See page A-59 for cables for maintenance.

#### ④ Options

Name	Option code	Page	Standard Price
Flange	FL	→ A-44	—
Foot bracket	FT	→ A-48	—

### Actuator Specifications

Item	Description
Drive method	Ball screw, ø6mm, rolled C10
Positioning repeatability	±0.02mm
Lost motion	0.1mm or less
Rod	ø12mm
Rod non-rotation precision	±2.1 deg
Ambient operating temperature/humidity	0 to 40°C, 85% RH max. (Non-condensing)

Dimensional Drawings

CAD drawings can be downloaded from the website. [www.intelligentactuator.com](http://www.intelligentactuator.com)



\* The RA2C is not available in non-motor end configuration, due to its construction.

- (\*1) Connect the motor and encoder cables here. (See page A-59 for details on cables.)
  - (\*2) After homing, the rod moves to the ME, therefore, please watch for any interference with surrounding objects.
- ME : Mechanical end  
SE : Stroke end

For Special Orders Appendix P.15

Note:  
Do not apply any external force on the rod from any direction other than the direction of the rod's motion. If a force is exerted on the rod in a perpendicular or rotational direction, the detent may become damaged.

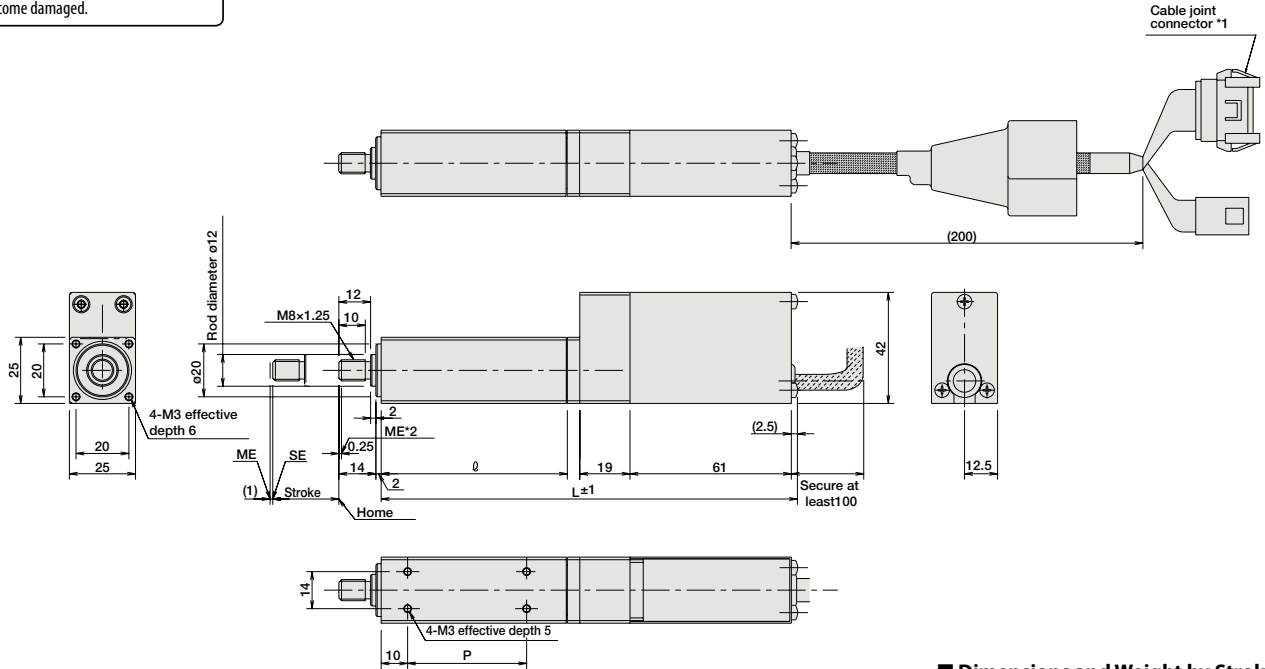

**■ Dimensions and Weight by Stroke**

Stroke	25	50	75	100
$\phi$	70	95	120	145
L	157.5	182.5	207.5	232.5
P	45	70	95	120
Weight (kg)	0.4	0.5	0.6	0.7

② Applicable Controllers

RCP2 series actuators can be operated with the controllers indicated below. Select the type according to your intended application.

Name	External view	Model number	Features	Maximum number of positioning points	Input power	Power-supply capacity	Standard price	Reference page
Solenoid Valve Type		PMEC-C-20PI-①-2-②	Easy-to-use controller, even for beginners	3 points	AC100V AC200V	Refer to P541	—	→ P537
		PSEP-C-20PI-①-2-0	Simple controller operable with the same signal as a solenoid valve					→ P547
Solenoid valve multi-axis type PIO specification		MSEP-C-③-④-2-0	Positioner type based on PIO control, allowing up to 8 axes to be connected	256 points	DC24V	Refer to P572	—	→ P563
Solenoid valve multi-axis type Network specification		MSEP-C-③-④-0-0	Field network-ready positioner type, allowing up to 8 axes to be connected					→ P607
Positioner type High-output specification		PCON-CA-20PI-①-2-0	Equipped with a high-output driver Positioner type based on PIO control	512 points	DC24V	Refer to P618	—	→ P607
Pulse-train type High-output specification		PCON-CA-20PI-PL□-2-0	Equipped with a high-output driver Pulse-train input type	(—)				
Field network type High-output specification		PCON-CA-20PI-④-0-0	Equipped with a high-output driver Supporting 7 major field networks	768 points				
Pulse Train Input Type (Differential Line Driver)		PCON-PL-20PI-①-2-0	Pulse train input type with differential line driver support	(—)	DC24V	Refer to P628	—	→ P623
Pulse Train Input Type (Open Collector)		PCON-PO-20PI-①-2-0	Pulse train input type with open collector support					
Serial Communication Type		PCON-SE-20PI-N-0-0	Dedicated Serial Communication	64 points	DC24V	Refer to P671	—	→ P665
Program Control Type		PSEL-CS-1-20PI-①-2-0	Programmed operation is possible. Can operate up to 2 axes	1,500 points	DC24V	Refer to P671	—	→ P665

\* This is for the single-axis PSEL. \* ① indicates I/O type (NP/PN). \* ② indicates power supply voltage (1: 100V / 2: 100~240V). \* ③ indicates number of axes (1 to 8). \* ④ indicates field network specification symbol. \* □ indicates N (NPN specification) or P (PNP specification) symbol.

- Slider Type
- Mini
- Standard
- Controller Integrated
- Rod Type
- Mini
- Standard
- Controllers Integrated
- Table/Arm/Flat Type
- Mini
- Standard
- Gripper/Rotary Type
- Linear Servo Type
- Clean-room Type
- Splash-Proof Type
- Pulse Motor
- Servo Motor (24V)
- Servo Motor (200V)
- Linear Servo Motor

# RCP2-RA3C

ROBO Cylinder, Rod Type, Actuator Width 35mm, Pulse Motor, Straight Type

<b>Model Specification Items</b>	<b>RCP2</b> — <b>RA3C</b> — <b>I</b> — <b>28P</b> — <input type="checkbox"/> — <input type="checkbox"/> — <input type="checkbox"/> — <input type="checkbox"/> — <input type="checkbox"/>
Series — Type — Encoder type — Motor type — Lead — Stroke — Applicable controller — Cable length — Options	I: Incremental *The Simple absolute encoder is also considered type "I". 28P: Pulse motor, 28□ size 5: 5mm 2.5: 2.5mm 50: 50mm ? 200: 200mm (50mm pitch increments) P1: PCON-PL/PO/SE PSEL P3: PCON-CA PMEC/PSEP MSEP N: None P: 1m S: 3m M: 5m X□□: Custom length X□□: Robot cable See Options below.

\* See page Pre-47 for details on the model descriptions.

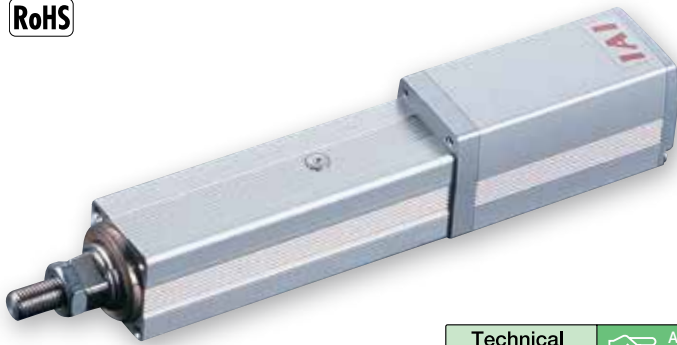

Technical References Appendix P.5

- POINT**  
Notes on Selection
- When the stroke increases, the maximum speed will drop to prevent the ball screw from reaching the critical rotational speed. Use the actuator specification table below to check the maximum speed at the stroke you desire.
  - Since the RCP2 series use a pulse motor, the load capacity decreases at high speeds. Check in the Speed vs. Load Capacity graph to see if your desired speed and load capacity are supported.
  - The load capacity is based on operation at an acceleration of 0.02G. In addition, the horizontal load capacity is based on the use of an external guide. If an external force is exerted on the rod from a direction other than the motion of the rod, the detent may become damaged.
  - See page A-71 for details on push motion.

### Speed vs. Load Capacity

Due to the characteristics of the pulse motor, the RCP2 series' load capacity decreases at high speeds. In the table below, check if your desired speed and load capacity are supported.

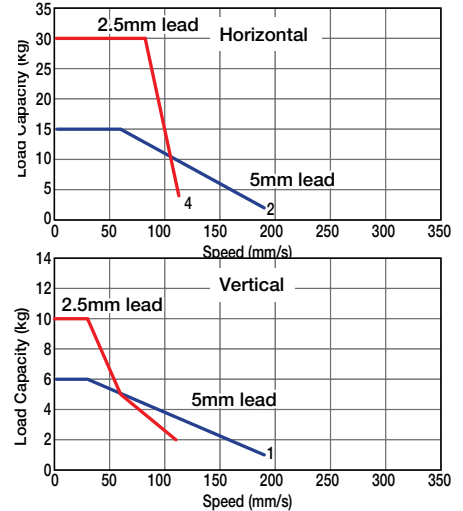

### Actuator Specifications

#### Leads and Payloads

(Note 1) Please note that the maximum load capacity decreases as the speed increases.

Model number	Lead (mm)	Maximum payload (Note 1)		Maximum pushing force (Note 2)	Stroke (mm)
		Horizontal (kg)	Vertical (kg)		
RCP2-RA3C-I-28P-5-①-②-③-④	5	~15	~6	73.5	50 to 200 (every 50mm)
RCP2-RA3C-I-28P-2.5-①-②-③-④	2.5	~30	~10	156.8	50 to 200 (every 50mm)

#### Stroke and Maximum Speed

Stroke / Lead	50~200 (every 50mm)	
	5	187
2.5	114	

Code explanation ① Stroke ② Applicable Controller ③ Cable length ④ Options \*See page A-71 for details on push motion. (Unit: mm/s)

#### ① Stroke

① Stroke (mm)	Standard price
50	—
100	—
150	—
200	—

#### ③ Cable Length

Type	Cable symbol	Standard price
Standard type	P (1m)	—
	S (3m)	—
	M (5m)	—
Special length	X06 (6m) ~ X10 (10m)	—
	X11 (11m) ~ X15 (15m)	—
	X16 (16m) ~ X20 (20m)	—
	R01 (1m) ~ R03 (3m)	—
Robot cable	R04 (4m) ~ R05 (5m)	—
	R06 (6m) ~ R10 (10m)	—
	R11 (11m) ~ R15 (15m)	—
	R16 (16m) ~ R20 (20m)	—
	R16 (16m) ~ R20 (20m)	—

\* See page A-59 for cables for maintenance.

#### ④ Options

Name	Option code	Page	Standard Price
Flange	FL	→ A-44	—
Foot bracket	FT	→ A-48	—
Non-motor end specification	NM	→ A-52	—

### Actuator Specifications

Item	Description
Drive method	Ball screw, ø8mm, rolled C10
Positioning repeatability	±0.02mm
Lost motion	0.1mm or less
Rod	ø22mm
Rod non-rotation precision	±1.5 deg
Ambient operating temperature/humidity	0 to 40°C, 85% RH max. (Non-condensing)

Dimensional Drawings

CAD drawings can be downloaded from the website. [www.intelligentactuator.com](http://www.intelligentactuator.com)



For Special Orders Appendix P.15

Note:  
Do not apply any external force on the rod from any direction other than the direction of the rod's motion. If a force is exerted on the rod in a perpendicular or rotational direction, the detent may become damaged.

- (\*1) Connect the motor and encoder cables here. (See page A-59 for details on cables.)
- (\*2) When homing, the rod moves to the ME; therefore, please watch for any interference with the surrounding objects.  
ME: Mechanical end  
SE: Stroke end
- (\*3) The orientation of the bolt will vary depending on the product.

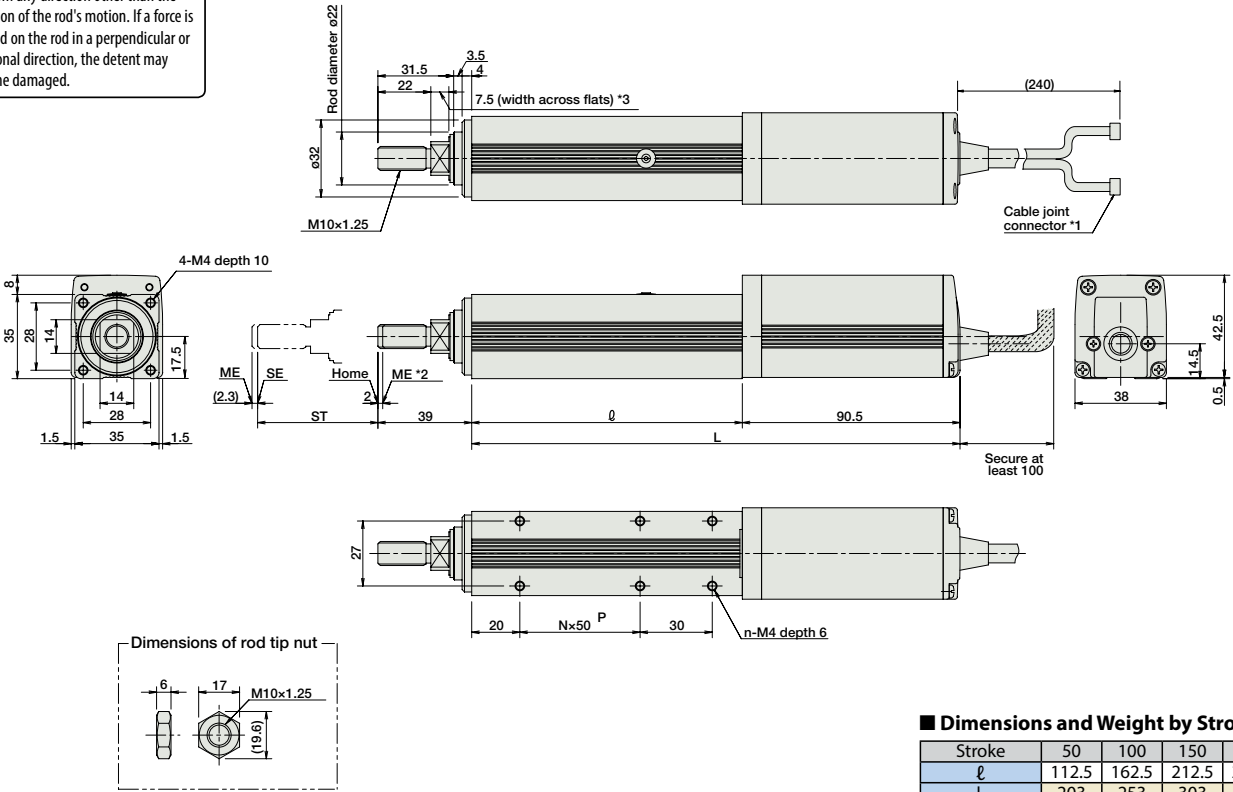

**Dimensions and Weight by Stroke**

Stroke	50	100	150	200
$\ell$	112.5	162.5	212.5	262.5
L	203	253	303	353
N	1	2	3	4
n	6	8	10	12
Weight (kg)	0.8	0.95	1.1	1.25

Applicable Controllers

RCP2 series actuators can be operated with the controllers indicated below. Select the type according to your intended application.

Name	External view	Model number	Features	Maximum number of positioning points	Input power	Power-supply capacity	Standard price	Reference page
Solenoid Valve Type		PMEC-C-28SPI-①-2-②	Easy-to-use controller, even for beginners	3 points	AC100V AC200V	Refer to P541	—	→ P537
		PSEP-C-28SPI-①-2-0	Simple controller operable with the same signal as a solenoid valve					→ P547
Solenoid valve multi-axis type PIO specification		MSEP-C-③④⑤⑥⑦⑧⑨⑩⑪⑫⑬⑭⑮⑯⑰⑱⑲⑳㉑㉒㉓㉔㉕㉖㉗㉘㉙㉚㉛㉜㉝㉞㉟㊱㊲㊳㊴㊵㊶㊷㊸㊹㊺㊻㊼㊽㊾㊿	Positioner type based on PIO control, allowing up to 8 axes to be connected	256 points	DC24V	Refer to P572	—	→ P563
Solenoid valve multi-axis type Network specification		MSEP-C-③④⑤⑥⑦⑧⑨⑩⑪⑫⑬⑭⑮⑯⑰⑱⑲⑳㉑㉒㉓㉔㉕㉖㉗㉘㉙㉚㉛㉜㉝㉞㉟㊱㊲㊳㊴㊵㊶㊷㊸㊹㊺㊻㊼㊽㊾㊿	Field network-ready positioner type, allowing up to 8 axes to be connected					→ P607
Positioner type High-output specification		PCON-CA-28SPI-①-2-0	Equipped with a high-output driver Positioner type based on PIO control	512 points	DC24V	Refer to P618	—	→ P607
Pulse-train type High-output specification		PCON-CA-28SPI-PL□-2-0	Equipped with a high-output driver Pulse-train input type	(—)				
Field network type High-output specification		PCON-CA-28SPI-④⑤⑥⑦⑧⑨⑩⑪⑫⑬⑭⑮⑯⑰⑱⑲⑳㉑㉒㉓㉔㉕㉖㉗㉘㉙㉚㉛㉜㉝㉞㉟㊱㊲㊳㊴㊵㊶㊷㊸㊹㊺㊻㊼㊽㊾㊿	Equipped with a high-output driver Supporting 7 major field networks	768 points				
Pulse Train Input Type (Differential Line Driver)		PCON-PL-28SPI-①-2-0	Pulse train input type with differential line driver support	(—)	DC24V	Refer to P628	—	→ P623
Pulse Train Input Type (Open Collector)		PCON-PO-28SPI-①-2-0	Pulse train input type with open collector support					
Serial Communication Type		PCON-SE-28SPI-N-0-0	Dedicated Serial Communication	64 points	DC24V	Refer to P671	—	→ P665
Program Control Type		PSEL-CS-1-28SPI-①-2-0	Programmed operation is possible. Can operate up to 2 axes	1,500 points	DC24V	Refer to P671	—	→ P665

\* This is for the single-axis PSEL. \* ① indicates I/O type (NP/PN). \* ② indicates power supply voltage (1: 100V / 2: 100~240V). \* ③④⑤⑥⑦⑧⑨⑩⑪⑫⑬⑭⑮⑯⑰⑱⑲⑳㉑㉒㉓㉔㉕㉖㉗㉘㉙㉚㉛㉜㉝㉞㉟㊱㊲㊳㊴㊵㊶㊷㊸㊹㊺㊻㊼㊽㊾㊿ indicates number of axes (1 to 8). \* ④⑤⑥⑦⑧⑨⑩⑪⑫⑬⑭⑮⑯⑰⑱⑲⑳㉑㉒㉓㉔㉕㉖㉗㉘㉙㉚㉛㉜㉝㉞㉟㊱㊲㊳㊴㊵㊶㊷㊸㊹㊺㊻㊼㊽㊾㊿ indicates field network specification symbol. \* □ indicates N (NPN specification) or P (PNP specification) symbol.



- Slider Type
- Mini
- Standard
- Controller Integrated
- Rod Type
- Mini
- Standard
- Controllers Integrated
- Table/Arm/Flat Type
- Mini
- Standard
- Gripper/Rotary Type
- Linear Servo Type
- Clean-room Type
- Splash-Proof Type
- Pulse Motor
- Servo Motor (24V)
- Servo Motor (200V)
- Linear Servo Motor

# RCP2-RA8C

ROBO Cylinder, High-Thrust Rod Type, Motor Unit Coupled, Actuator Width 85mm, 24-V Pulse Motor

**Model Specification Items**

**RCP2** — **RA8C** — **I** — **60P** —  —  — **P4** —  —

Series — Type — Encoder type — Motor type — Lead — Stroke — Applicable controller — Cable length — Options

I: Incremental      60P: Pulse motor, 60□ size      10: 10mm, 5: 5mm      50: 50mm, 300: 300mm (every 50mm)      P4: PCON-CFA      N: None, P: 1m, S: 3m, M: 5m, X□□: Custom length, X□□: Robot cable

See Options below.

\* See page Pre-47 for details on the model descriptions.



Technical References Appendix P.5

- POINT** Notes on Selection
- (1) The load capacity is based on operation at an acceleration of 0.1G for 5mm-lead, and 0.2G for 10mm-lead. These values are the upper limits for the acceleration.
  - (2) Please note that the controller for the RA8C will be the PCON-CFA (for high-thrust motors).
  - (3) The horizontal load capacity is based on the use of an external guide.
  - (4) See page A-71 for details on push motion.

### Speed vs. Load Capacity

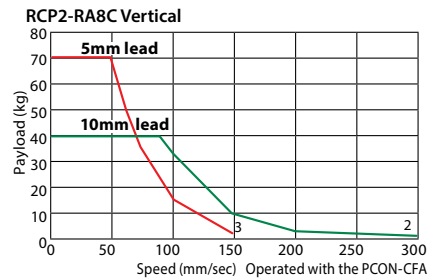
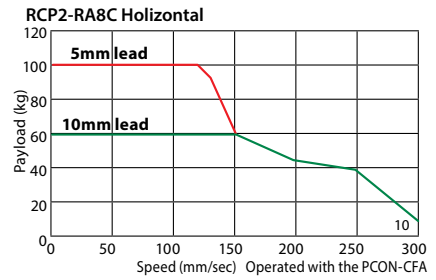

### Actuator Specifications

#### Leads and Payloads

Model number	Lead (mm)	Connection cable	Maximum payload		Maximum pushing force (N)	Stroke (mm)
			Horizontal (kg)	Vertical (kg)		
RCP2-RA8C-I-60P-10-①-P4-②-③	10	PCON-CFA	60	40	1,000	50 to 300 (every 50mm)
RCP2-RA8C-I-60P-5-①-P4-②-③	5	PCON-CFA	100	70	2,000	50 to 300 (every 50mm)

Code explanation ① Stroke ② Cable length ③ Options \*See page A-71 for details on push motion.

#### Stroke and Maximum Speed

Stroke / Lead	50~300 (every 50mm)	
	10	300
5	150	

(Unit: mm/s)

#### ① Stroke

① Stroke (mm)	Standard price
50	—
100	—
150	—
200	—
250	—
300	—

#### ② Cable Length

Type	Cable symbol	Standard price
Standard type	P (1m)	—
	S (3m)	—
	M (5m)	—
Special length	X06 (6m) ~ X10 (10m)	—
	X11 (11m) ~ X15 (15m)	—
	X16 (16m) ~ X20 (20m)	—
	R01 (1m) ~ R03 (3m)	—
Robot cable	R04 (4m) ~ R05 (5m)	—
	R06 (6m) ~ R10 (10m)	—
	R11 (11m) ~ R15 (15m)	—
	R16 (16m) ~ R20 (20m)	—
	R20 (20m)	—

\* See page A-59 for cables for maintenance.

#### ③ Options

Name	Option code	Page	Standard Prices
Connector cable exit direction	A1 ~ A3	→ A-41	—
Brake	B	→ A-42	—
Flange	FL	→ A-44	—
Foot bracket	FT	→ A-48	—
Non-motor end specification	NM	→ A-52	—

#### Actuator Specifications

Item	Description
Drive method	Ball screw, ø16mm, rolled C10
Positioning repeatability	±0.02mm
Lost motion	0.1mm or less
Rod	ø40mm Stainless steel pipe
Rod non-rotation precision	±1.0 deg
Ambient operating temperature/humidity	0 to 40°C, 85% RH max. (Non-condensing)

- Slider Type
- Mini
- Standard
- Controller Integrated
- Rod Type
- Mini
- Standard
- Controllers Integrated
- Table/Arm/Flat Type
- Mini
- Standard
- Gripper/Rotary Type
- Linear Servo Type
- Clean-room Type
- Splash-Proof Type
- Pulse Motor
- Servo Motor (24V)
- Servo Motor (200V)
- Linear Servo Motor

**Dimensional Drawings**

CAD drawings can be downloaded from the website. [www.intelligentactuator.com](http://www.intelligentactuator.com)

For Special Orders Appendix P.15



- (\*1) Connect the motor and encoder cables here.
- (\*2) During home return, the rod will move all the way to the ME. Accordingly, pay attention to prevent possible contact between the rod and surrounding parts during home return.  
ME: Mechanical End SE: Stroke End  
Reference dimensions are shown in parentheses.
- (\*3) The orientation of the bolt will vary depending on the product.
- (\*4) When installing the actuator by using flange and front housing, be careful not to apply external force to the main body.  
ME: Mechanical end SE: Stroke end

Note:  
Do not apply any external force on the rod from any direction other than the direction of the rod's motion. If a force is exerted on the rod in a perpendicular or rotational direction, the detent may become damaged.

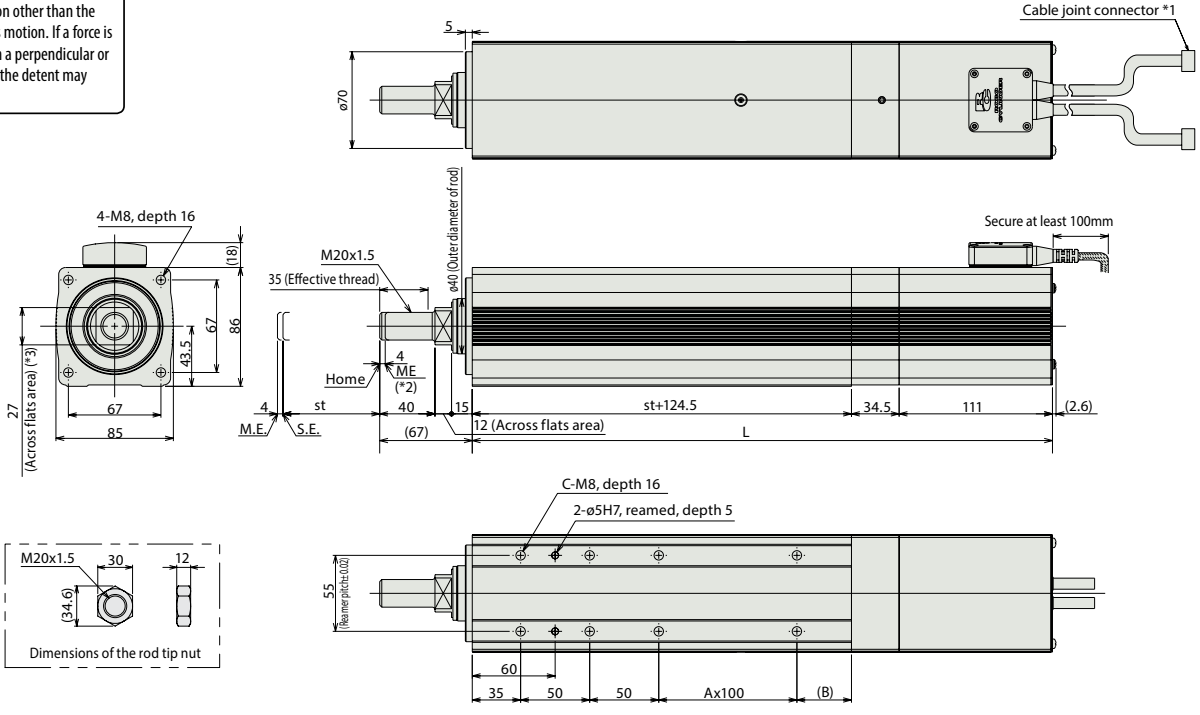

**Dimensions of the flange type**

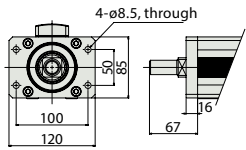

**Dimensions of the foot bracket type**

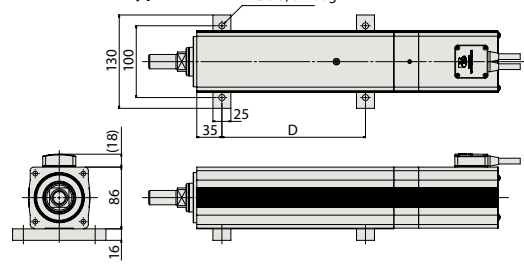

**Dimensions of the brake type**

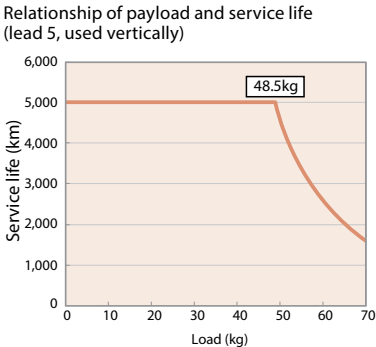
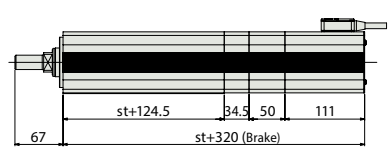

**Dimensions and Weights by Stroke (mm)**

Stroke	50	100	150	200	250	300
L	320	370	420	470	520	570
A	0	0	1	1	2	2
B	39.5	89.5	39.5	89.5	39.5	89.5
C	6	6	8	8	10	10
D	100	100	200	200	300	300
Weight (kg)	without brake	6.5	7.4	8.2	9.1	9.9
	with brake	7.5	8.4	9.2	10.1	10.9

**Applicable Controllers**

RCP2 series actuators can be operated with the controllers indicated below. Select the type according to your intended application.

Name	External view	Model number	Features	Maximum number of positioning points	Input power	Power-supply capacity	Standard price	Reference page
Positioner type		PCON-CFA-60PI-NP-□-0-□ PCON-CFA-60PI-PN-□-0-□	Equipped with a high-output driver Positioner type based on PIO control	512 points	DC24V	Refer to P618	—	→ P607
Pulse-train type		PCON-CFA-60PI-PLN-□-0-□ PCON-CFA-60PI-PLP-□-0-□	Equipped with a high-output driver Pulse-train input type	(—)				
Field network type		PCON-CFA-60PI-□-0-0-□	Equipped with a high-output driver Supporting 7 major field networks	768 points				

\* □ indicates field network specification symbol (DV, CC, PR, CN, ML, EC, EP).





# RCP2-RA8R

ROBO Cylinder, High-Thrust Rod Type, Side-mounted Motor Type, Actuator Width 85mm, 24-V Pulse Motor

Model Specification Items	<b>RCP2</b> — <b>RA8R</b> — <b>I</b> — <b>60P</b> — <input type="checkbox"/> — <input type="checkbox"/> — <b>P4</b> — <input type="checkbox"/> — <input type="checkbox"/>
Series — Type — Encoder type — Motor type — Lead — Stroke — Applicable controller — Cable length — Options	Series — Type — Encoder type — Motor type — Lead — Stroke — Applicable controller — Cable length — Options
	I: Incremental 60P: Pulse motor, 60□size 10: 10mm 5: 5mm 50: 50mm ? 300: 300mm (every 50mm) P4: PCON-CFA N: None P: 1m S: 3m M: 5m X□□: Custom length X□□: Robot cable See Options below. * Please specify side-mounted motor direction by an option code.

\* See page Pre-47 for details on the model descriptions.

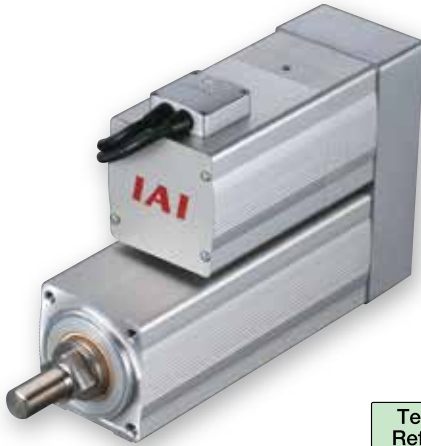

Technical References Appendix P.5

- POINT** Notes on Selection
- (1) The load capacity is based on operation at an acceleration of 0.1G for 5mm-lead, and 0.2G for 10mm-lead. These values are the upper limits for the acceleration.
  - (2) Please note that the controller for the RA8R will be the PCON-CFA (for high-thrust motors).
  - (3) The horizontal load capacity is based on the use of an external guide.
  - (4) See page A-71 for details on push motion.

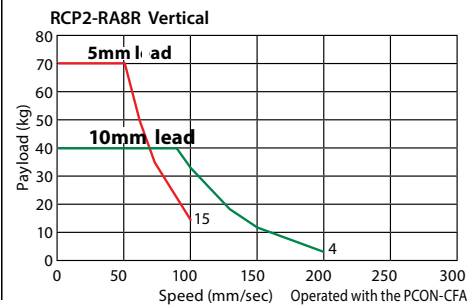
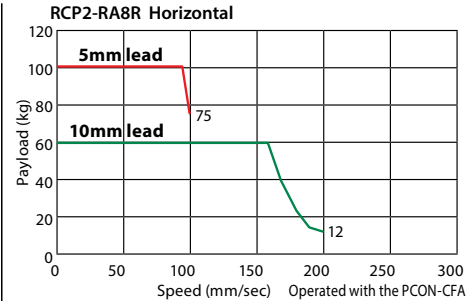

## Actuator Specifications

### Leads and Payloads

Model number	Lead (mm)	Connection cable	Maximum payload		Maximum pushing force (N)	Stroke (mm)	Stroke / Lead	
			Horizontal (kg)	Vertical (kg)			Stroke	50~300 (every 50mm)
RCP2-RA8R-I-60P-10-①-P4-②-③	10	PCON-CFA	60	40	1,000	50 to 300 (every 50mm)	10	200
RCP2-RA8R-I-60P-5-①-P4-②-③	5	PCON-CFA	100	70	2,000	5	5	100

Code explanation ① Stroke ② Cable length ③ Options \*See page A-71 for details on push motion.

(Unit: mm/s)

### ① Stroke

① Stroke (mm)	Standard price
50	—
100	—
150	—
200	—
250	—
300	—

### ② Cable Length

Type	Cable symbol	Standard price
Standard type	P (1m)	—
	S (3m)	—
	M (5m)	—
Special length	X06 (6m) ~ X10 (10m)	—
	X11 (11m) ~ X15 (15m)	—
	X16 (16m) ~ X20 (20m)	—
	R01 (1m) ~ R03 (3m)	—
Robot cable	R04 (4m) ~ R05 (5m)	—
	R06 (6m) ~ R10 (10m)	—
	R11 (11m) ~ R15 (15m)	—
	R16 (16m) ~ R20 (20m)	—

\* See page A-59 for cables for maintenance.

### ③ Options

Name	Option code	Page	Standard Prices
Connector cable exit direction	A1 ~ A3	→ A-41	—
Brake	B	→ A-42	—
Flange	FL	→ A-44	—
Foot bracket	FT	→ A-48	—
Non-motor end specification	NM	→ A-52	—
Side-mounted motor at the top	MT1/MT2/MT3	→ A-57	—
Side-mounted motor to the right	MR1/MR2	→ A-57	—
Side-mounted motor to the left	ML1/ML3	→ A-57	—

### Actuator Specifications

Item	Description
Drive method	Ball screw, ø16mm, rolled C10
Positioning repeatability	±0.02mm
Lost motion	0.1mm or less
Rod	ø40mm Stainless steel pipe
Rod non-rotation precision	±1.0 deg
Ambient operating temperature/humidity	0 to 40°C, 85% RH max. (Non-condensing)

Dimensional Drawings

CAD drawings can be downloaded from the website. [www.intelligentactuator.com](http://www.intelligentactuator.com)

For Special Orders Appendix P.15



- (\*1) Connect the motor and encoder cables here.
  - (\*2) When homing, the rod moves to the ME; therefore, please watch for any interference with the surrounding objects.
  - (\*3) The orientation of the bolt will vary depending on the product.
  - (\*4) When installing the actuator by using flange and front housing, be careful not to apply external force to the main body.
- ME : Mechanical end  
SE : Stroke end

Note:  
Do not apply any external force on the rod from any direction other than the direction of the rod's motion. If a force is exerted on the rod in a perpendicular or rotational direction, the detent may become damaged.

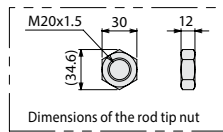
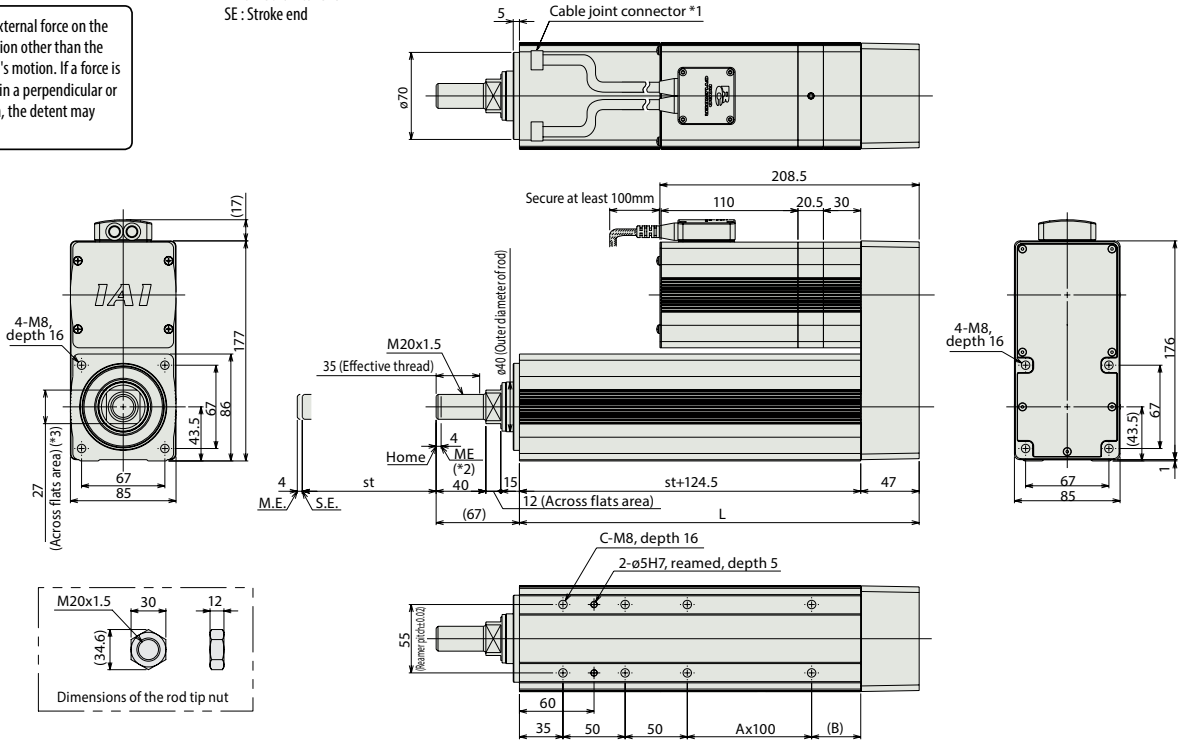

Dimensions of the flange type

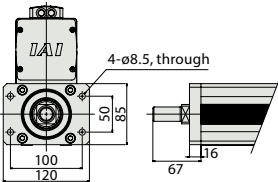

Dimensions of the foot bracket type

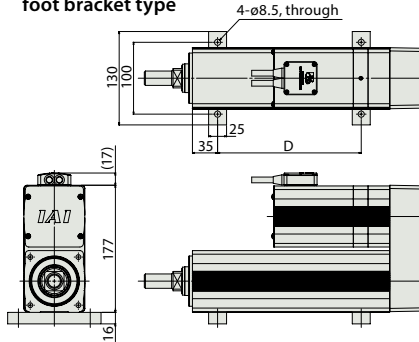

Dimensions of the brake type

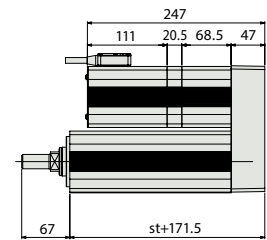

Relationship of payload and service life (lead 5, used vertically)

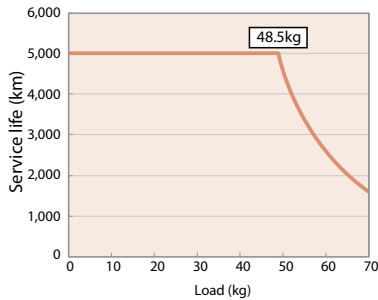

■ Dimensions and Weights by Stroke (mm)

Stroke	50	100	150	200	250	300	
L	221.5	271.5	321.5	371.5	421.5	471.5	
A	0	0	1	1	2	2	
B	39.5	89.5	39.5	89.5	39.5	89.5	
C	6	7	8	8	10	10	
D	100	100	200	200	300	300	
Weight (kg)	without brake	7.7	8.6	9.4	10.3	11.1	12
	with brake	8.6	9.5	10.3	11.2	12.0	12.9

Applicable Controllers

RCP2 series actuators can be operated with the controllers indicated below. Select the type according to your intended application.

Name	External view	Model number	Features	Maximum number of positioning points	Input power	Power-supply capacity	Standard price	Reference page
Positioner type		PCON-CFA-60PI-NP-□-0-□ PCON-CFA-60PI-PN-□-0-□	Equipped with a high-output driver Positioner type based on PIO control	512 points	DC24V	Refer to P618	—	→ P607
Pulse-train type		PCON-CFA-60PI-PLN-□-0-□ PCON-CFA-60PI-PLP-□-0-□	Equipped with a high-output driver Pulse-train input type	(—)				
Field network type		PCON-CFA-60PI-①-0-0-□	Equipped with a high-output driver Supporting 7 major field networks	768 points				

\* ① indicates field network specification symbol (DV, CC, PR, CN, ML, EC, EP).



- Slider Type
- Mini
- Standard
- Controller Integrated
- Rod Type
- Mini
- Standard
- Controllers Integrated
- Table/Arm/Flat Type
- Mini
- Standard
- Gripper/Rotary Type
- Linear Servo Type
- Clean-room Type
- Splash-Proof Type
- Pulse Motor
- Servo Motor (24V)
- Servo Motor (200V)
- Linear Servo Motor

# RCP2-RA10C

ROBO Cylinder, High-Thrust Rod Type, Actuator Width 100mm, Pulse Motor, Straight Type

Model Specification Items	<b>RCP2</b>	<b>RA10C</b>	<b>I</b>	<b>86P</b>	<input type="checkbox"/>	<input type="checkbox"/>	<b>P4</b>	<input type="checkbox"/>	<input type="checkbox"/>
	Series	Type	Encoder type	Motor type	Lead	Stroke	Applicable controller	Cable length	Options
			I: Incremental	86P: Pulse motor, size 86□	10: 10mm 5: 5mm 2.5: 2.5mm	50: 50mm ? 300: 300mm (50mm pitch increments)	P4: PCON-CFA	N: None P: 1m S: 3m M: 5m X□□: Custom length R□□: Robot cable	See Options below.

\* See page Pre-47 for details on the model descriptions.

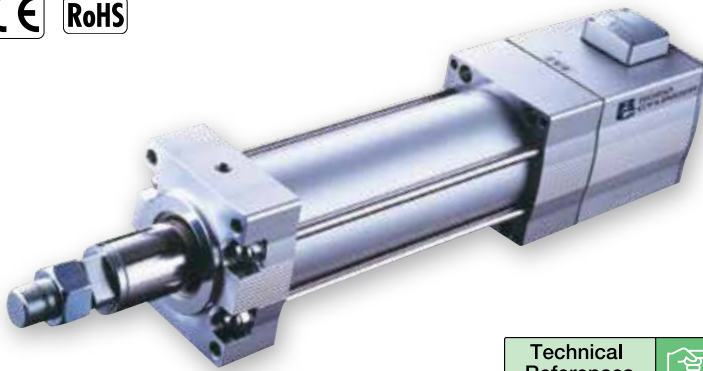

Technical References Appendix P.5

- POINT** Notes on Selection
- (1) Minimum speed is set per each lead. (10mm-lead: 10mm/s, 5mm-lead: 5mm/s, 2.5-lead: 1mm/s) Please note that if the actuator is operated below the minimum speed, vibration may occur.
  - (2) Since the RCP2 series use a pulse motor, the load capacity decreases at high speeds. Check in the Speed vs. Load Capacity graph to see if your desired speed and load capacity are supported.
  - (3) The load capacity is based on operation at an acceleration of 0.04G for 10mm-lead, 0.02G for 5mm-lead, and 0.01G for 2.5-lead. This is the upper limit of the acceleration. In addition, the horizontal load capacity is based on the use of an external guide. If an external force is exerted on the rod from a direction other than the motion of the rod, the detent may become damaged.
  - (4) See page A-71 for details on push motion.

### Speed vs. Load Capacity

Due to the characteristics of the pulse motor, the RCP2 series' load capacity decreases at high speeds. In the table below, check if your desired speed and load capacity are supported.

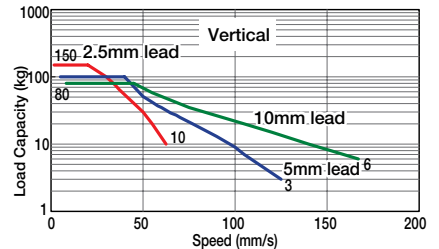
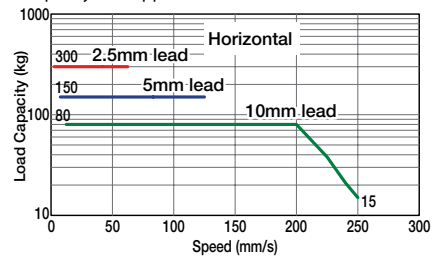

### Actuator Specifications

#### Leads and Payloads

(Note 1) Please note that the maximum load capacity decreases as the speed increases.

Model number	Lead (mm)	Maximum payload (Note 1)		Positioning repeatability (mm)	Stroke (mm)
		Horizontal (kg)	Vertical (kg)		
RCP2-RA10C-1-86P-10-①-P4-②-③	10	~80	~80	1,500	50 to 300 (every 50mm)
RCP2-RA10C-1-86P-5-①-P4-②-③	5	150	~100	3,000	
RCP2-RA10C-1-86P-2.5-①-P4-②-③	2.5	300	~150	6,000	

Legend ① Stroke ② Cable length ③ Options \*See page A-71 for details on push motion.

#### Stroke and Maximum Speed

Stroke / Lead	50~300 (every 50mm)
10	250 <167>
5	125
2.5	63

The values in <> apply when the actuator is used vertically. (Unit: mm/s)

#### ① Stroke

① Stroke (mm)	Standard price
50	—
100	—
150	—
200	—
250	—
300	—

#### ② Cable Length

Type	Cable symbol	Standard price
Standard type	P (1m)	—
	S (3m)	—
	M (5m)	—
Special length	X06 (6m) ~ X10 (10m)	—
	X11 (11m) ~ X15 (15m)	—
	X16 (16m) ~ X20 (20m)	—
	R01 (1m) ~ R03 (3m)	—
Robot cable	R04 (4m) ~ R05 (5m)	—
	R06 (6m) ~ R10 (10m)	—
	R11 (11m) ~ R15 (15m)	—
	R16 (16m) ~ R20 (20m)	—

\* See page A-59 for cables for maintenance.

#### ③ Options

Name	Option code	Page	Standard Price
Connector cable exit direction	A1 ~ A3	→ A-41	—
Brake	B	→ A-42	—
Flange	FL	→ A-46	—
Foot bracket	FT	→ A-48	—

#### Actuator Specifications

Item	Description
Drive method	Ball screw, ø20mm, rolled C10
Positioning repeatability	±0.02mm
Lost motion	0.1mm or less
Rod diameter	ø40mm
Rod non-rotation precision	±1.0 deg
Ambient operating temperature/humidity	0 to 40°C, 85% RH max. (Non-condensing)

- Slider Type
- Mini
- Standard
- Controller Integrated
- Rod Type
- Mini
- Standard
- Controllers Integrated
- Table/ Arm/ Flat Type
- Mini
- Standard
- Gripper/ Rotary Type
- Linear Servo Type
- Clean-room Type
- Splash-Proof Type
- Pulse Motor
- Servo Motor (24V)
- Servo Motor (200V)
- Linear Servo Motor

Dimensional Drawings

CAD drawings can be downloaded from the website. [www.intelligentactuator.com](http://www.intelligentactuator.com)

For Special Orders Appendix P.15



\* The RA10C is not available in non-motor end configuration, due to its construction.

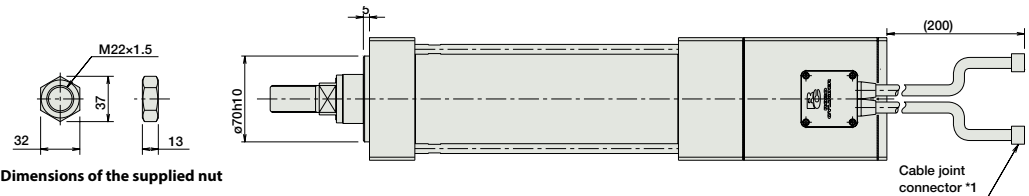

Dimensions of the supplied nut

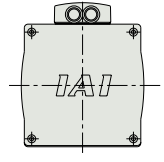
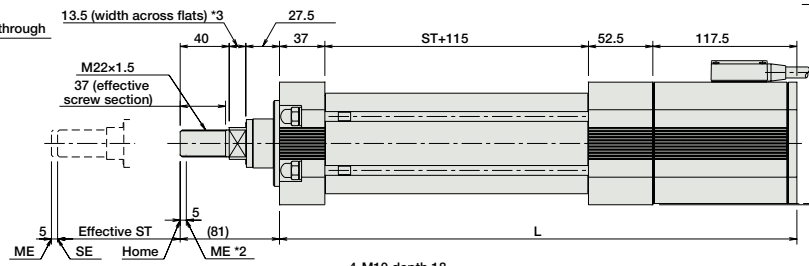
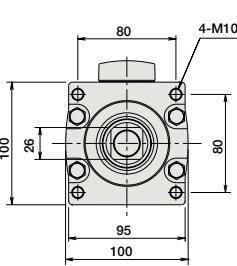

- (\*1) Connect the motor and encoder cables here. Please note that although the motor cable is the same as RCP2 series, the encoder cable is series-specific. (See page A-59 for details on cables.)
- (\*2) During home return, be careful to avoid interference from peripheral objects because the slider travels until the mechanical end.  
ME : Mechanical end  
SE : Stroke end  
The values enclosed in "( )" are reference dimensions.
- (\*3) The orientation of the bolt varies depending on the product.

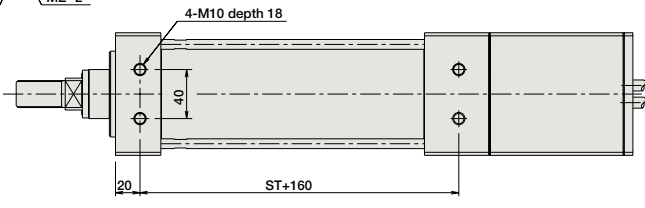

Dimensions of the brake section

\* Compared to the standard model, the brake-equipped model is longer by 45.5mm and heavier by 1.5kg.

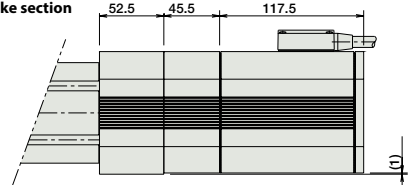

Note:  
Do not apply any external force on the rod from any direction other than the direction of the rod's motion. If a force is exerted on the rod in a perpendicular or rotational direction, the detent may become damaged.

Dimensions and Weights by Stroke

Stroke	50	100	150	200	250	300
L	372	422	472	522	572	622
Weight (kg)	9	9.5	10	10.5	11	11.5

Vertical Payload and Service Life

The service life of a rod-type ROBO Cylinder is 5,000km. However, since the RCP2-RA10C has a larger maximum thrust compared to other types, its service life will largely depend on the load capacity and pushing force used. Therefore, when selecting your product using the Speed vs. Load Capacity, or Pushing Force vs. Current Limit graphs, check the service life using the Load Capacity vs. Load Capacity, and Pushing Force vs. Load Capacity graphs.

Note:  
The rated value is the maximum value that can meet a service life of 5,000km. The maximum value is the value at which it is still operable. Please note that operation with values exceeding the rated value will result in a decrease in the service life, as shown in the graphs.

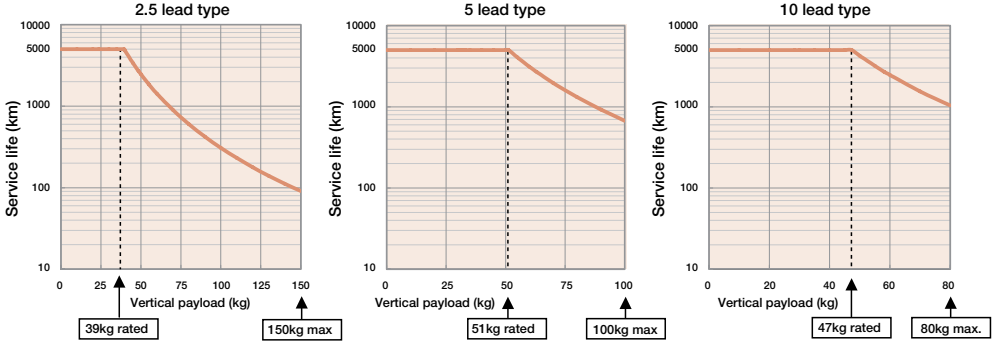

Applicable Controllers

RCP2 series actuators can be operated with the controllers indicated below. Select the type according to your intended application.

Name	External view	Model number	Features	Maximum number of positioning points	Input power	Power-supply capacity	Standard price	Reference page
Positioner type		PCON-CFA-86PI-NP-□-0-□ PCON-CFA-86PI-PN-□-0-□	Equipped with a high-output driver Positioner type based on PIO control	512 points	DC24V	Refer to P618	—	→ P607
Pulse-train type		PCON-CFA-86PI-PLN-□-0-□ PCON-CFA-86PI-PLP-□-0-□	Equipped with a high-output driver Pulse-train input type	(—)				
Field network type		PCON-CFA-86PI-①-0-0-□	Equipped with a high-output driver Supporting 7 major field networks	768 points				

\* ① indicates field network specification symbol (DV, CC, PR, CN, ML, EC, EP).



RCP2-RA10C Sold & Serviced By  
**172 ELECTROMATE**  
 Toll Free Phone (877) SERV098  
 Toll Free Fax (877) SERV099  
[www.electromate.com](http://www.electromate.com)  
[sales@electromate.com](mailto:sales@electromate.com)

# RCP2-SRA4R

ROBO Cylinder, Short-length Rod Type, Actuator Width 45mm, Pulse Motor, Side-mounted Motor

<b>Model Specification Items</b>	<b>RCP2</b> — <b>SRA4R</b> — <b>I</b> — <b>35P</b> — □ — □ — □ — □ — □
Series — Type — Encoder type — Motor type — Lead — Stroke — Applicable controller — Cable length — Options	
I: Incremental encoder is also considered type "I".	35P: Pulse motor, size 35□
5: 5mm	2.5: 2.5mm
20: 20mm	200: 200mm (10mm pitch increments) * 50mm increments over 100mm
P1: PCON-PL/PO/SE PSEL	N: None
P3: PCON-CA PMEC/PSEP MSEP	P: 1m
	S: 3m
	M: 5m
	X□□: Custom length

\* See options below.

\* See page Pre-47 for details on the model descriptions.



Technical References Appendix P.5

- POINT** Notes on Selection
- (1) Since the RCP2 series use a pulse motor, the load capacity decreases at high speeds. Check in the Speed vs. Load Capacity graph to see if your desired speed and load capacity are supported.
  - (2) The load capacity is based on operation at an acceleration of 0.3G (0.2G is for the 2.5mm-lead model, or when used vertically). This is the upper limit of the acceleration.
  - (3) The horizontal load capacity is based on the use of an external guide. If an external force is exerted on the rod from a direction other than the motion of the rod, the detent may become damaged.
  - (4) See page A-71 for details on push motion.

### Speed vs. Load Capacity

Due to the characteristics of the pulse motor, the RCP2 series' load capacity decreases at high speeds. In the table below, check if your desired speed and load capacity are supported.

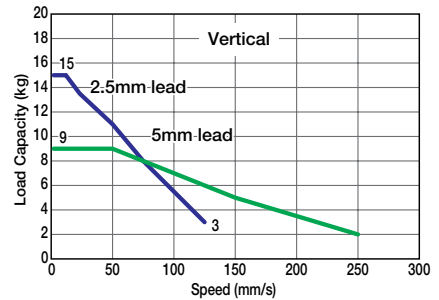
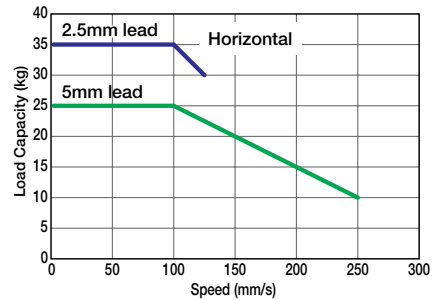

### Actuator Specifications

**Leads and Payloads** (Note 1) Please note that the maximum load capacity decreases as the speed increases. (Note 2) 50mm increments over 100mm.

Model number	Lead (mm)	Maximum payload (Note 1)		Positioning repeatability (mm)	Stroke (mm)
		Horizontal (kg)	Vertical (kg)		
RCP2-SRA4R-1-35P-5-①-②-③-④	5	~25	~9	112	20 to 200 (every 10mm) (Note 2)
RCP2-SRA4R-1-35P-2.5-①-②-③-④	2.5	~35	~15	224	

**Stroke and Maximum Speed**

Stroke / Lead	20~200 (every 10mm)
5	250
2.5	125

Legend ① Stroke ② Applicable Controller ③ Cable length ④ Options \*See page A-71 for details on push motion. (Unit: mm/s)

#### ① Stroke

① Stroke (mm)	Standard price
25 ~ 50	—
60 ~ 100	—
150	—
200	—

#### ③ Cable Length

Type	Cable symbol	Standard price
Standard type (Robot cable)	P (1m)	—
	S (3m)	—
	M (5m)	—
Special length	X06 (6m) ~ X10 (10m)	—
	X11 (11m) ~ X15 (15m)	—
	X16 (16m) ~ X20 (20m)	—
		—

\* The cable is a motor-encoder integrated cable, and is provided as a robot cable.

\* See page A-59 for cables for maintenance.

#### ④ Options

Name	Option code	Page	Standard Price
Brake	B	→ A-42	—
Flange bracket (front)	FL	→ A-44	—
Flange bracket (rear)	FLR	→ A-46	—
Foot bracket 1 (base mounting)	FT	→ A-48	—
Foot bracket 2 (right/left side mounting)	FT2/FT4	→ A-48	—
Non-motor end specification	NM	→ A-52	—

\* The brake is available for strokes of 70mm or more.

### Actuator Specifications

Item	Description
Drive method	Ball screw, ø8mm, rolled C10
Positioning repeatability	±0.02mm
Lost motion	0.1mm or less
Rod diameter	ø22mm
Rod non-rotation precision	—
Ambient operating temperature/humidity	0 to 40°C, 85% RH max. (Non-condensing)

Dimensional Drawings

CAD drawings can be downloaded from the website. [www.intelligentactuator.com](http://www.intelligentactuator.com)

For Special Orders Appendix P.15

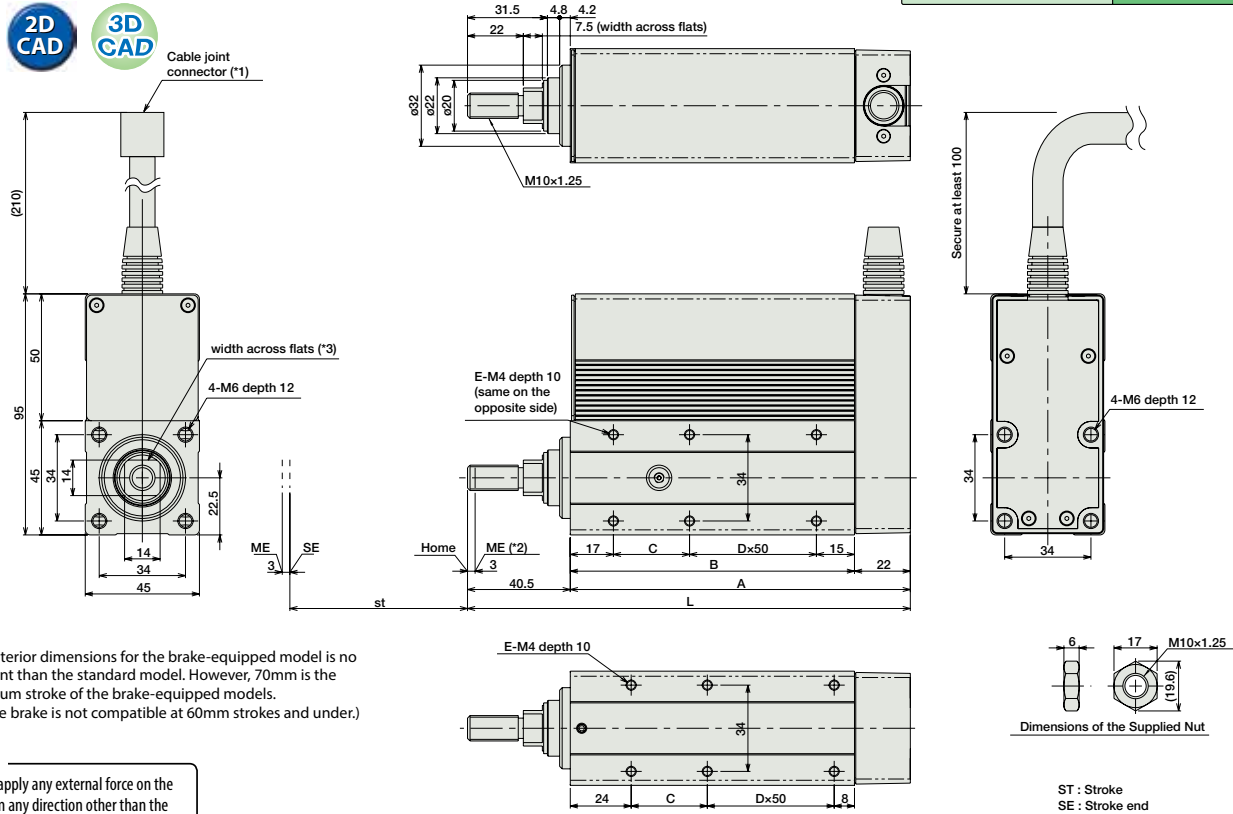

\* The exterior dimensions for the brake-equipped model is no different than the standard model. However, 70mm is the minimum stroke of the brake-equipped models. (i.e. The brake is not compatible at 60mm strokes and under.)

Note:  
Do not apply any external force on the rod from any direction other than the direction of the rod's motion. If a force is exerted on the rod in a perpendicular or rotational direction, the detent may become damaged.

- (\*1) Connect the motor-encoder integrated cable here. (See page A-59 for details on cables.)
- (\*2) During home return, be careful to avoid interference from peripheral objects because the rod moves until the mechanical end.
- (\*3) The orientation of the bolt varies depending on the product.

■ Dimensions and Weights by Stroke (Add 0.2kg for brake equipped)

Stroke	20	30	40	50	60	70	80	90	100	150	200
L	124.5	134.5	144.5	154.5	164.5	174.5	184.5	194.5	204.5	254.5	304.5
A	84	94	104	114	124	134	144	154	164	214	264
B	62	72	82	92	102	112	122	132	142	192	242
C	30	40	50	60	70	30	40	50	60	60	60
D	0	0	0	0	0	1	1	1	1	2	3
E	4	4	4	4	4	6	6	6	6	8	10
Weight (kg)	0.83	0.89	0.96	1.02	1.08	1.14	1.21	1.27	1.33	1.64	1.95

② Applicable Controllers

RCP2 series actuators can be operated with the controllers indicated below. Select the type according to your intended application.

Name	External view	Model number	Features	Maximum number of positioning points	Input power	Power-supply capacity	Standard price	Reference page
Solenoid Valve Type		PMEC-C-35PI-①-2-②	Easy-to-use controller, even for beginners	3 points	AC100V AC200V	Refer to P541	—	→ P537
		PSEP-C-35PI-①-2-0	Simple controller operable with the same signal as a solenoid valve					→ P547
Solenoid valve multi-axis type PIO specification		MSEP-C-③-①-2-0	Positioner type based on PIO control, allowing up to 8 axes to be connected	256 points	DC24V	Refer to P572	—	→ P563
Solenoid valve multi-axis type Network specification		MSEP-C-③-④-0-0	Field network-ready positioner type, allowing up to 8 axes to be connected					→ P607
Positioner type High-output specification		PCON-CA-35PI-①-2-0	Equipped with a high-output driver Positioner type based on PIO control	512 points	DC24V	Refer to P618	—	→ P623
Pulse-train type High-output specification		PCON-CA-35PI-PL□-2-0	Equipped with a high-output driver Pulse-train input type	(—)				
Field network type High-output specification		PCON-CA-35PI-④-0-0	Equipped with a high-output driver Supporting 7 major field networks	768 points				
Pulse Train Input Type (Differential Line Driver)		PCON-PL-35PI-①-2-0	Pulse train input type with differential line driver support	(—)	DC24V	Refer to P628	—	→ P665
Pulse Train Input Type (Open Collector)		PCON-PO-35PI-①-2-0	Pulse train input type with open collector support					
Serial Communication Type		PCON-SE-35PI-N-0-0	Dedicated Serial Communication	64 points	DC24V	Refer to P671	—	→ P665
Program Control Type		PSEL-CS-1-35PI-①-2-0	Programmed operation is possible. Can operate up to 2 axes	1,500 points	DC24V	Refer to P671	—	→ P665

\* This is for the single-axis PSEL. \* ① indicates I/O type (NP/PN). \* ② indicates power supply voltage (1: 100V / 2: 100~240V). \* ③ indicates number of axes (1 to 8). \* ④ indicates field network specification symbol. \* □ indicates N (NPN specification) or P (PNP specification) symbol.

- Slider Type
- Mini
- Standard
- Controller Integrated
- Rod Type
- Mini
- Standard
- Controllers Integrated
- Table/Arm/Flat Type
- Mini
- Standard
- Gripper/Rotary Type
- Linear Servo Type
- Clean-room Type
- Splash-Proof Type
- Pulse Motor
- Servo Motor (24V)
- Servo Motor (200V)
- Linear Servo Motor

# RCP2-SRGS4R

ROBO Cylinder, Short-length Rod Type with Single Guide, Actuator Width 45mm, Pulse Motor, Side-mounted Motor

Model Specification Items	<b>RCP2</b> – <b>SRGS4R</b> –	<b>I</b> –	<b>35P</b> –	<input type="checkbox"/> –	<input type="checkbox"/> –	<input type="checkbox"/> –	<input type="checkbox"/> –	<input type="checkbox"/>
	Series – Type	Encoder type	Motor type	Lead	Stroke	Applicable controller	Cable length	Options
		I: Incremental *The Simple absolute encoder is also considered type "I".	35P: Pulse motor, size 35□	5: 5mm 2.5: 2.5mm	20: 20mm 200: 200mm (10mm pitch increments) * 50mm increments over 100mm	P1: PCON-PL/PO/SE PSEL P3: PCON-CA PMEC/PSEP MSEP	N: None P: 1m S: 3m M: 5m X□□: Custom length	* See options below.

\* See page Pre-47 for details on the model descriptions.



Technical References Appendix P.5

- POINT** Notes on Selection
- (1) Since the RCP2 series use a pulse motor, the load capacity decreases at high speeds. Check in the Speed vs. Load Capacity graph to see if your desired speed and load capacity are supported.
  - (2) The load capacity is based on operation at an acceleration of 0.03G (0.2G is for the 2.5mm-lead model, or when used vertically). This is the upper limit of the acceleration.
  - (3) The horizontal load capacity is based on the use of an external guide. See the technical resources (page A-109) for the allowable weight using the supplied guide alone.
  - (4) See page A-71 for details on push motion.

### Speed vs. Load Capacity

Due to the characteristics of the pulse motor, the RCP2 series' load capacity decreases at high speeds. In the table below, check if your desired speed and load capacity are supported.

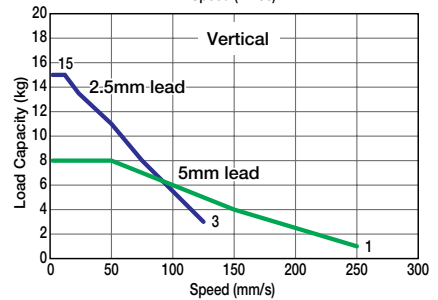
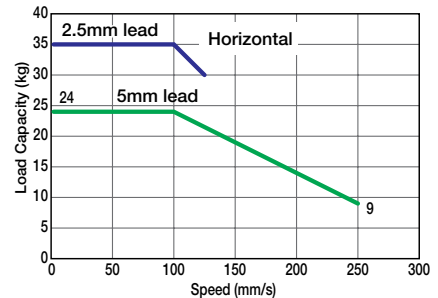

### Actuator Specifications

**Leads and Payloads** (Note 1) Please note that the maximum load capacity decreases as the speed increases. (Note 2) 50mm increments over 100mm.

Model number	Lead (mm)	Maximum payload (Note 1)		Positioning repeatability (mm)	Stroke (mm)
		Horizontal (kg)	Vertical (kg)		
RCP2-SRGS4R-1-35P-5-①-②-③-④	5	~24	~8	112	20 to 200 (every 10mm) (Note 2)
RCP2-SRGS4R-1-35P-2.5-①-②-③-④	2.5	~35	~15	224	(every 10mm) (Note 2)

**Stroke and Maximum Speed**

Stroke / Lead	20~200 (every 10mm)	
	5	250
2.5	125	

Legend ① Stroke ② Applicable Controller ③ Cable length ④ Options \*See page A-71 for details on push motion. (Unit: mm/s)

#### ① Stroke

① Stroke (mm)	Standard price
20 ~ 50	—
60 ~ 100	—
150	—
200	—

#### ③ Cable Length

Type	Cable symbol	Standard price
Standard type (Robot cable)	P (1m)	—
	S (3m)	—
	M (5m)	—
Special length	X06 (6m) ~ X10 (10m)	—
	X11 (11m) ~ X15 (15m)	—
	X16 (16m) ~ X20 (20m)	—

\* The cable is a motor-encoder integrated cable, and is provided as a robot cable.  
\* See page A-59 for cables for maintenance.

#### ④ Options

Name	Option code	Page	Standard Price
Brake	B	→ A-42	—
Flange bracket (rear)	FLR	→ A-46	—
Foot bracket 2 (right/left side mounting)	FT2/FT4	→ A-47	—
Guide mounting direction	GS2 ~ GS4	→ A-50	—
Non-motor end specification	NM	→ A-52	—

\* The brake is available for strokes of 70mm or more.  
\* Please be sure that the mounting direction of the guide is specified in the product name.  
\* The guide and the foot bracket cannot be mounted in the same direction.  
(Combination of FT2 and FT4, GS4 and GS2 can be mounted. The foot bracket cannot be mounted in the GS3 direction.)

### Actuator Specifications

Item	Description
Drive method	Ball screw, ø8mm, rolled C10
Positioning repeatability	±0.02mm
Lost motion	0.1mm or less
Rod diameter	ø22mm
Rod non-rotation precision	±0.05 deg
Ambient operating temperature/humidity	0 to 40°C, 85% RH max. (Non-condensing)

**175** RCP2-SRGS4R

Dimensional Drawings

CAD drawings can be downloaded from the website. [www.intelligentactuator.com](http://www.intelligentactuator.com)

For Special Orders Appendix P.15

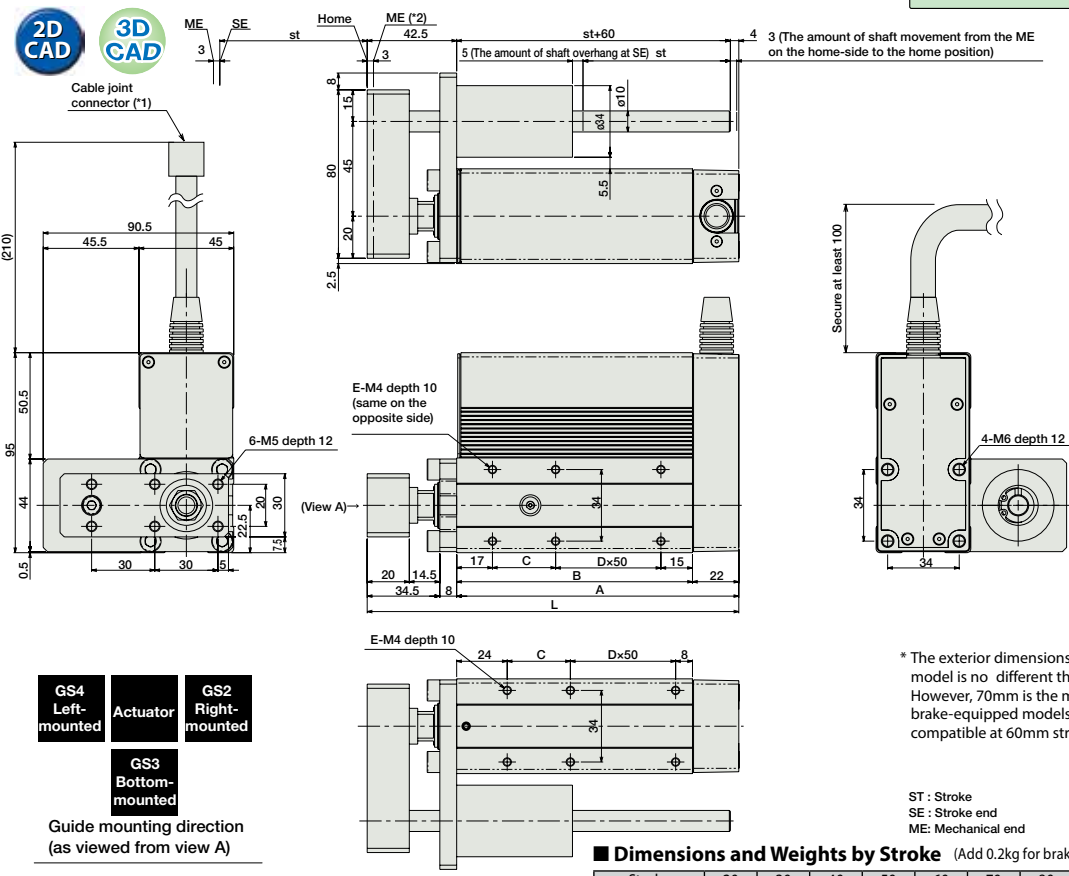

GS4 Left-mounted Actuator GS2 Right-mounted  
GS3 Bottom-mounted  
Guide mounting direction (as viewed from view A)

\* The exterior dimensions for the brake-equipped model is no different than the standard model. However, 70mm is the minimum stroke of the brake-equipped models. (i.e. The brake is not compatible at 60mm strokes and under.)

ST : Stroke  
SE : Stroke end  
ME : Mechanical end

Dimensions and Weights by Stroke (Add 0.2kg for brake equipped)

Stroke	20	30	40	50	60	70	80	90	100	150	200
L	126.5	136.5	146.5	156.5	166.5	176.5	186.5	196.5	206.5	256.5	306.5
A	84	94	104	114	124	134	144	154	164	214	264
B	62	72	82	92	102	112	122	132	142	192	242
C	30	40	50	60	70	80	90	100	110	160	210
D	0	0	0	0	0	1	1	1	1	2	3
E	4	4	4	4	4	6	6	6	6	8	10
Weight (kg)	1.2	1.27	1.34	1.41	1.48	1.54	1.61	1.68	1.75	2.09	2.43

(\*1) Connect the motor-encoder integrated cable here. (See page A-59 for details on cables.)  
(\*2) When homing, the rod moves to the mechanical end position; therefore, please watch for any interference with the surrounding objects.

Applicable Controllers

RCP2 series actuators can be operated with the controllers indicated below. Select the type according to your intended application.

Name	External view	Model number	Features	Maximum number of positioning points	Input power	Power-supply capacity	Standard price	Reference page
Solenoid Valve Type		PMEC-C-35PI-①-2-②	Easy-to-use controller, even for beginners	3 points	AC100V AC200V	Refer to P541	—	→ P537
		PSEP-C-35PI-①-2-0	Simple controller operable with the same signal as a solenoid valve					→ P547
Solenoid valve multi-axis type PIO specification		MSEP-C-③-④-①-2-0	Positioner type based on PIO control, allowing up to 8 axes to be connected	256 points	DC24V	Refer to P572	—	→ P563
Solenoid valve multi-axis type Network specification		MSEP-C-③-④-④-0-0	Field network-ready positioner type, allowing up to 8 axes to be connected					→ P607
Positioner type High-output specification		PCON-CA-35PI-①-2-0	Equipped with a high-output driver Positioner type based on PIO control	512 points	DC24V	Refer to P618	—	→ P623
Pulse-train type High-output specification		PCON-CA-35PI-PL□-2-0	Equipped with a high-output driver Pulse-train input type	(—)				
Field network type High-output specification		PCON-CA-35PI-④-0-0	Equipped with a high-output driver Supporting 7 major field networks	768 points				
Pulse Train Input Type (Differential Line Driver)		PCON-PL-35PI-①-2-0	Pulse train input type with differential line driver support	(—)	DC24V	Refer to P628	—	→ P665
Pulse Train Input Type (Open Collector)		PCON-PO-35PI-①-2-0	Pulse train input type with open collector support					
Serial Communication Type		PCON-SE-35PI-N-0-0	Dedicated Serial Communication	64 points	DC24V	Refer to P671	—	→ P665
Program Control Type		PSEL-CS-1-35PI-①-2-0	Programmed operation is possible. Can operate up to 2 axes	1,500 points	DC24V	Refer to P671	—	→ P665

\* This is for the single-axis PSEL. \* ① indicates I/O type (NP/PN). \* ② indicates power supply voltage (1: 100V / 2: 100~240V).  
\* ③ indicates number of axes (1 to 8). \* ④ indicates field network specification symbol. \* □ indicates N (NPN specification) or P (PNP specification) symbol.



# RCP2-SRGD4R

ROBO Cylinder, Short-length Rod Type with Double Guide, Actuator Width 45mm, Pulse Motor, Side-mounted Motor

<b>Model Specification Items</b>	<b>RCP2</b> — <b>SRGD4R</b> — <b>I</b> — <b>35P</b> — □ — □ — □ — □ — □
Series — Type — Encoder type — Motor type — Lead — Stroke — Applicable controller — Cable length — Options	<p>I: Incremental *The Simple absolute encoder is also considered type "I".</p> <p>35P: Pulse motor, size 35□</p> <p>5: 5mm 2.5: 2.5mm</p> <p>20: 20mm 200: 200mm (10mm pitch increments) *50mm increments over 100mm</p> <p>P1: PCON-PL/PO/SE PSEL P3: PCON-CA PMEC/PSEP MSEP</p> <p>N: None P: 1m S: 3m M: 5m X□□: Custom length</p> <p>* See options below.</p>

\* See page Pre-47 for details on the model descriptions.



Technical References Appendix P.5

- POINT** Notes on Selection
- (1) Since the RCP2 series use a pulse motor, the load capacity decreases at high speeds. Check in the Speed vs. Load Capacity graph to see if your desired speed and load capacity are supported.
  - (2) The load capacity is based on operation at an acceleration of 0.03G (0.2G is for the 2.5mm-lead model, or when used vertically). This is the upper limit of the acceleration.
  - (3) The horizontal load capacity is based on the use of an external guide. See the technical resources (page A-110) for the allowable weight using the supplied guide alone.
  - (4) See page A-71 for details on push motion.

### Speed vs. Load Capacity

Due to the characteristics of the pulse motor, the RCP2 series' load capacity decreases at high speeds. In the table below, check if your desired speed and load capacity are supported.

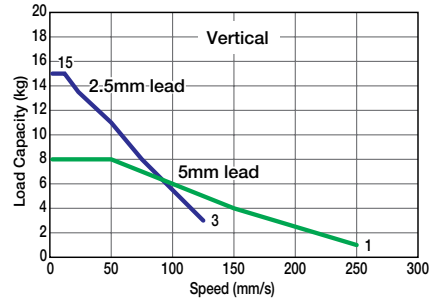
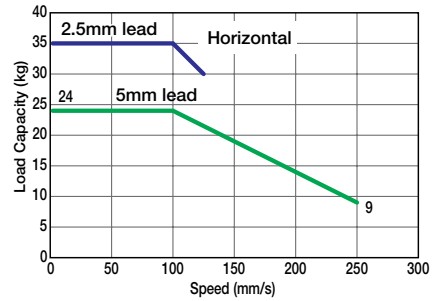

### Actuator Specifications

**Leads and Payloads** (Note 1) Please note that the maximum load capacity decreases as the speed increases. (Note 2) 50mm increments over 100mm.

Model number	Lead (mm)	Maximum payload (Note 1)		Positioning repeatability (mm)	Stroke (mm)
		Horizontal (kg)	Vertical (kg)		
RCP2-SRGD4R-1-35P-5-①-②-③-④	5	~24	~8	112	20 to 200 (every 10mm) (Note 2)
RCP2-SRGD4R-1-35P-2.5-①-②-③-④	2.5	~35	~15	224	

**Stroke and Maximum Speed**

Stroke / Lead	20~200 (every 10mm)	
	5	250
2.5	125	

Legend ① Stroke ② Applicable Controller ③ Cable length ④ Options \*See page A-71 for details on push motion. (Unit: mm/s)

#### ① Stroke

① Stroke (mm)	Standard price
25 ~ 50	—
60 ~ 100	—
150	—
200	—

#### ③ Cable Length

Type	Cable symbol	Standard price
Standard type (Robot cable)	P (1m)	—
	S (3m)	—
	M (5m)	—
Special length	X06 (6m) ~ X10 (10m)	—
	X11 (11m) ~ X15 (15m)	—
	X16 (16m) ~ X20 (20m)	—

\* The cable is a motor-encoder integrated cable, and is provided as a robot cable.  
\* See page A-59 for cables for maintenance.

#### ④ Options

Name	Option code	Page	Standard Price
Brake	B	→ A-42	—
Flange bracket (rear)	FLR	→ A-46	—
Non-motor end specification	NM	→ A-52	—

\* The brake is available for strokes of 70mm or more.

### Actuator Specifications

Item	Description
Drive method	Ball screw, ø8mm, rolled C10
Positioning repeatability	±0.02mm
Lost motion	0.1mm or less
Rod diameter	ø22mm
Rod non-rotation precision	±0.05 deg
Ambient operating temperature/humidity	0 to 40°C, 85% RH max. (Non-condensing)

Dimensional Drawings

CAD drawings can be downloaded from the website.

www.intelligentactuator.com

For Special Orders

Appendix P.15

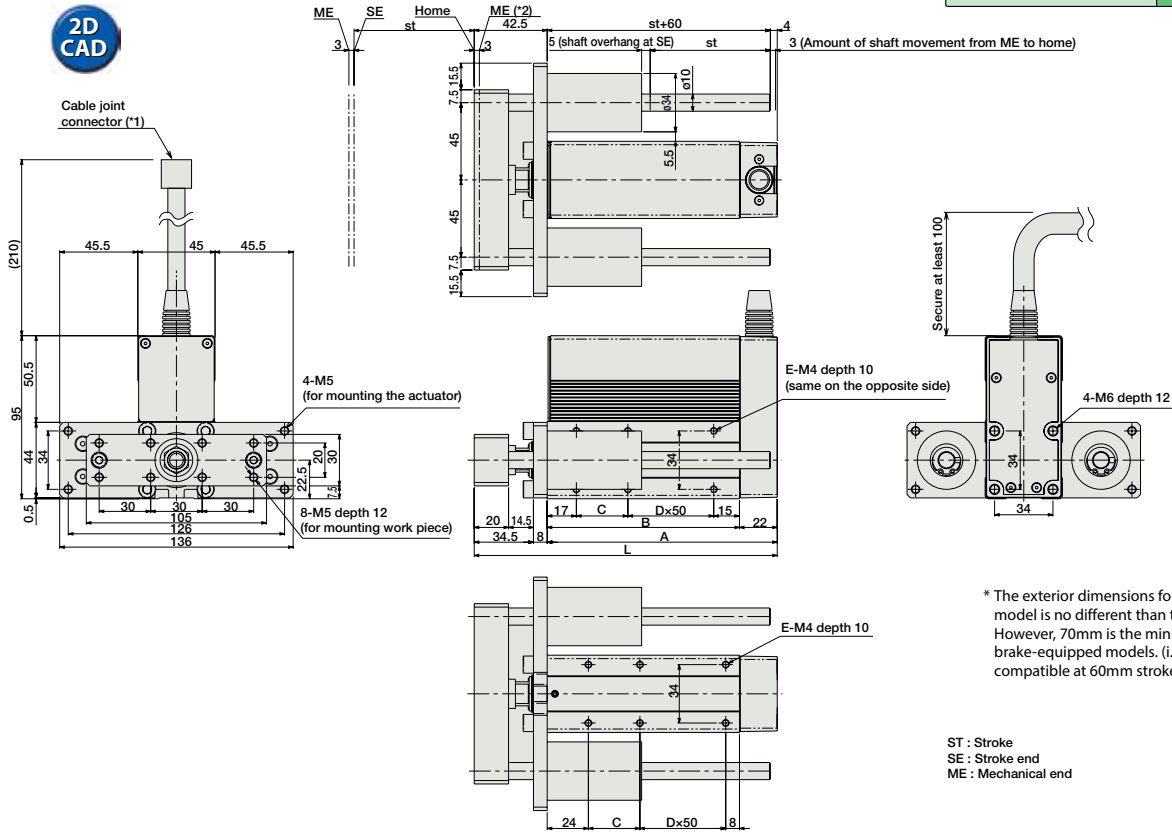

Dimensions and Weights by Stroke (Add 0.2kg for brake equipped)

Stroke	20	30	40	50	60	70	80	90	100	150	200
L	126.5	136.5	146.5	156.5	166.5	176.5	186.5	196.5	206.5	256.5	306.5
A	84	94	104	114	124	134	144	154	164	214	264
B	62	72	82	92	102	112	122	132	142	192	242
C	30	40	50	60	70	30	40	50	60	60	60
D	0	0	0	0	0	1	1	1	1	2	3
E	4	4	4	4	4	6	6	6	6	8	10
Weight (kg)	1.47	1.55	1.62	1.7	1.77	1.84	1.92	1.99	2.07	2.44	2.81

(\*1) Connect the motor-encoder integrated cable here. (See page A-59 for details on cables.)  
(\*2) When homing, the rod moves to the mechanical end position; therefore, please watch for any interference with the surrounding objects.

Applicable Controllers

RCP2 series actuators can be operated with the controllers indicated below. Select the type according to your intended application.

Name	External view	Model number	Features	Maximum number of positioning points	Input power	Power-supply capacity	Standard price	Reference page
Solenoid Valve Type		PMEC-C-35PI-①-2-②	Easy-to-use controller, even for beginners	3 points	AC100V AC200V	Refer to P541	—	→ P537
		PSEP-C-35PI-①-2-0	Simple controller operable with the same signal as a solenoid valve					→ P547
Solenoid valve multi-axis type PIO specification		MSEP-C-③-④-①-2-0	Positioner type based on PIO control, allowing up to 8 axes to be connected	256 points	DC24V	Refer to P572	—	→ P563
Solenoid valve multi-axis type Network specification		MSEP-C-③-④-④-0-0	Field network-ready positioner type, allowing up to 8 axes to be connected					→ P607
Positioner type High-output specification		PCON-CA-35PI-①-2-0	Equipped with a high-output driver Positioner type based on PIO control	512 points	DC24V	Refer to P618	—	→ P623
Pulse-train type High-output specification		PCON-CA-35PI-PL□-2-0	Equipped with a high-output driver Pulse-train input type	(—)				
Field network type High-output specification		PCON-CA-35PI-④-0-0	Equipped with a high-output driver Supporting 7 major field networks	768 points				
Pulse Train Input Type (Differential Line Driver)		PCON-PL-35PI-①-2-0	Pulse train input type with differential line driver support	(—)	DC24V	Refer to P628	—	→ P665
Pulse Train Input Type (Open Collector)		PCON-PO-35PI-①-2-0	Pulse train input type with open collector support					
Serial Communication Type		PCON-SE-35PI-N-0-0	Dedicated Serial Communication	64 points	DC24V	Refer to P671	—	→ P665
Program Control Type		PSEL-CS-1-35PI-①-2-0	Programmed operation is possible. Can operate up to 2 axes	1,500 points	DC24V	Refer to P671	—	→ P665

\* This is for the single-axis PSEL. \* ① indicates I/O type (NP/PN). \* ② indicates power supply voltage (1: 100V / 2: 100~240V).  
\* ③ indicates number of axes (1 to 8). \* ④ indicates field network specification symbol. \* □ indicates N (NPN specification) or P (PNP specification) symbol.

# ERC3-RA4C

Controller-Integrated, Rod Type, Actuator Width 45mm, Pulse Motor, Straight Type

Model Specification Items

**ERC3 - RA4C - I - 42P** - [ ] - [ ] - [ ] - [ ] - [ ] - [ ]

Series - Type - Encoder type - Motor type - Lead - Stroke - I/O type - Cable length - Controller Type - Options

I: Incremental 42□: Pulse motor 20: 20mm 12: 12mm 6: 6mm 3: 3mm 50: 50mm ? 300: 300mm (50mm pitch increments) NP: PIO (NPN) type PN: PIO (PNP) type SE: SIO type PLN: pulse-train (NPN) type PLP: pulse-train (PNP) type N: None P: 1m S: 3m M: 5m X□□: Custom length CN: CON type MC: MEC type B : Brake NM : Non-motor end ABU : Simple absolute specification FL : Flange FT : Foot bracket

\* See page Pre-47 for details on the model descriptions.



Technical References Appendix P.5

- POINT** Notes on Selection
- (1) If the high-output setting is enabled (factory default), the duty must be limited. (Refer to page A-95.) If the high-output setting is disabled, the payload and maximum speed become lower, but the actuator can be used at a duty of 100%. Refer to the operation manual for information on how to change the high-output setting.
  - (2) Refer to page A-99 for the payload at each speed/acceleration when the high-output setting is enabled.
  - (3) The value for the horizontal load capacity is with an external guide.
  - (4) See page A-71 for details on push motion.

### Speed vs. Load Capacity

Due to the characteristics of the pulse motor, the ERC3 series' load capacity decreases at high speeds. In the table below, check if your desired speed and load capacity are supported.

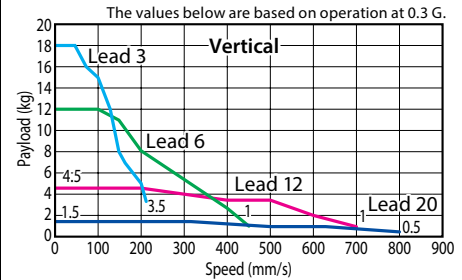
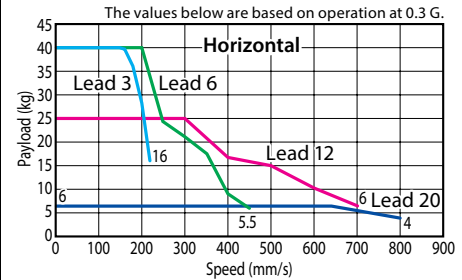

High-output setting enabled (Factory default)

### Actuator Specifications (High-output Setting Enabled)

#### Leads and Payloads

(Note 1) Please note that the maximum load capacity decreases as the speed increases.

Model number	Lead (mm)	Maximum payload (Note 1)		Maximum push force (N)	Stroke (mm)
		Horizontal (kg)	Vertical (kg)		
ERC3-RA4C-I-42P-20-①-②-③-④	20	6	1.5	56	50 to 300 (every 50mm)
ERC3-RA4C-I-42P-12-①-②-③-④	12	25	4.5	93	
ERC3-RA4C-I-42P-6-①-②-③-④	6	40	12	185	
ERC3-RA4C-I-42P-3-①-②-③-④	3	40	18	370	

Legend ① Stroke ② I/O type ③ Cable length ④ Options \*See page A-71 for details on push motion.

#### Stroke and Maximum Speed

Stroke / Lead	50~200 (every 50mm)	250 (mm)	300 (mm)
	20	800	
12	700	695	485
6	450	345	240
3	225	170	120

(Unit: mm/s)

#### ① Stroke

Stroke (mm)	Standard price
50	—
100	—
150	—
200	—
250	—
300	—

#### ③ Cable Length

Type	Cable symbol	Standard price
Standard (Robot Cables)	P (1m)	—
	S (3m)	—
	M (5m)	—
Special length	X06 (6m) ~ X10 (10m)	—

\* See page 586 for cables for maintenance.

#### ④ Options

Name	Option code	Page	Standard Price
Brake	B	→ A-42	—
Simple absolute specification	ABU	→ A-42	— (*)
Flange	FL	→ A-45	—
Foot bracket	FT	→ A-48	—
Non-motor end specification	NM	→ A-52	—

(\*) If the simple absolute specification is selected, SE (SIO type) I/O type and the separately sold PIO converter with simple absolute specification (with battery) are required.

#### Actuator Specifications

Item	Description
Drive method	Ball screw, ø10mm, rolled C10
Positioning repeatability (*)	±0.02mm [±0.03mm]
Lost motion (*)	0.1mm or less [0.2mm or less]
Rod diameter	ø25mm
Rod non-rotation precision	±1.5 deg
Ambient operating temperature/humidity	0 to 40°C, 85% RH max. (Non-condensing)

(\*) The specification in [ ] applies when the lead is 20mm.



# ERC3-RA6C

Controller-Integrated, Rod Type, Actuator Width 64mm, Pulse Motor, Straight Type

Model Specification Items

**ERC3 - RA6C - I - 56P** - [ ] - [ ] - [ ] - [ ] - [ ] - [ ]

Series - Type - Encoder type - Motor type - Lead - Stroke - I/O type - Cable length - Controller Type - Options

I: Incremental 56□: Pulse motor 24: 24mm 16: 16mm 8: 8mm 4: 4mm 50: 50mm 100: 100mm 200: 200mm 300: 300mm (50mm pitch increments) NP: PIO (NPN) type PN: PIO (PNP) type SE: SIO type PLN: pulse-train (NPN) type PLP: pulse-train (PNP) type N: None P: 1m S: 3m M: 5m X□□: Custom Length CN: CON type MC: MEC type B : Brake NM : Non-motor end ABU : Simple absolute specification FL : Flange FT : Foot bracket

\* See page Pre-47 for details on the model descriptions.

**RoHS**



Technical References Appendix P.5

**POINT**  
Notes on Selection

- (1) If the high-output setting is enabled (factory default), the duty must be limited. (Refer to page A-95.) If the high-output setting is disabled, the payload and maximum speed become lower, but the actuator can be used at a duty of 100%. Refer to the operation manual for information on how to change the high-output setting.
- (2) Refer to page A-99 for the payload at each speed/acceleration when the high-output setting is enabled.
- (3) The value for the horizontal load capacity is with an external guide.
- (4) See page A-71 for details on push motion.

**Speed vs. Load Capacity**

Due to the characteristics of the pulse motor, the ERC3 series' load capacity decreases at high speeds. In the table below, check if your desired speed and load capacity are supported.

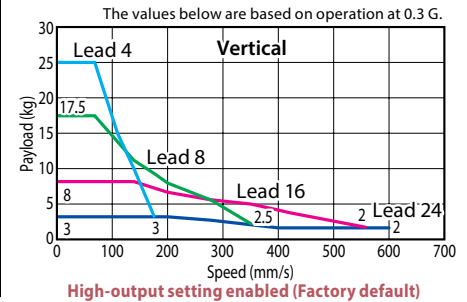
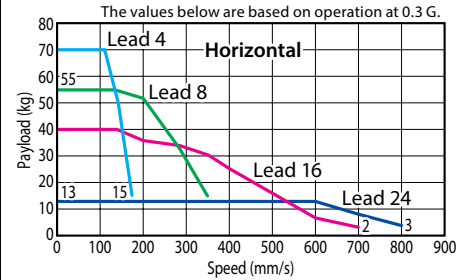

High-output setting enabled (Factory default)

**Actuator Specifications**

**Leads and Payloads**

(Note 1) Please note that the maximum load capacity decreases as the speed increases.

Model number	Lead (mm)	Maximum payload (Note 1)		Maximum push force (N)	Stroke (mm)
		Horizontal (kg)	Vertical (kg)		
ERC3-RA6C-I-56P-24-①-②-③-④	24	13	3	182	50 to 300 (every 50mm)
ERC3-RA6C-I-56P-16-①-②-③-④	16	40	8	273	
ERC3-RA6C-I-56P-8-①-②-③-④	8	55	17.5	547	
ERC3-RA6C-I-56P-4-①-②-③-④	4	70	25	1094	

Legend ① Stroke ② I/O type ③ Cable length ④ Options \*See page A-71 for details on push motion.

**Stroke and Maximum Speed**

Stroke Lead	50~250 (every 50mm)	300 (mm)
	24	800 <600>
16	700 <560>	
8	420	400
4	210 <175>	200 <175>

\* The values enclosed in < > apply to vertical settings. (Unit: mm/s)  
\* The values of lead 8 and lead 4 apply when acceleration is at 0.1G.

**① Stroke**

Stroke (mm)	Standard price
50	—
100	—
150	—
200	—
250	—
300	—

**④ Options**

Name	Option code	Page	Standard Price
Brake	<b>B</b>	→ A-42	—
Simple absolute specification	<b>ABU</b>	→ A-42	— (*)
Flange	<b>FL</b>	→ A-45	—
Foot bracket	<b>FT</b>	→ A-48	—
Non-motor end	<b>NM</b>	→ A-52	—

(\*) If the simple absolute specification is selected, SE (SIO type) I/O type and the separately sold PIO converter with simple absolute specification (with battery) are required.

**③ Cable Length**

Type	Cable symbol	Standard price
Standard (Robot Cables)	<b>P</b> (1m)	—
	<b>S</b> (3m)	—
	<b>M</b> (5m)	—
Special length	<b>X06</b> (6m) ~ <b>X10</b> (10m)	—

\* See page 586 for cables for maintenance.

**Actuator Specifications**

Item	Description
Drive method	Ball screw, ø10mm, rolled C10
Positioning repeatability (*)	±0.02mm [±0.03mm]
Lost motion (*)	0.1mm or less [0.2mm or less]
Rod diameter	ø25mm
Rod non-rotation precision	±1.5 deg
Ambient operating temperature/humidity	0 to 40°C, 85% RH max. (Non-condensing)

(\*) The specification in [ ] applies when the lead is 20mm.

Dimensional Drawings

CAD drawings can be downloaded from the website. [www.intelligentactuator.com](http://www.intelligentactuator.com)

For Special Orders Appendix P.15

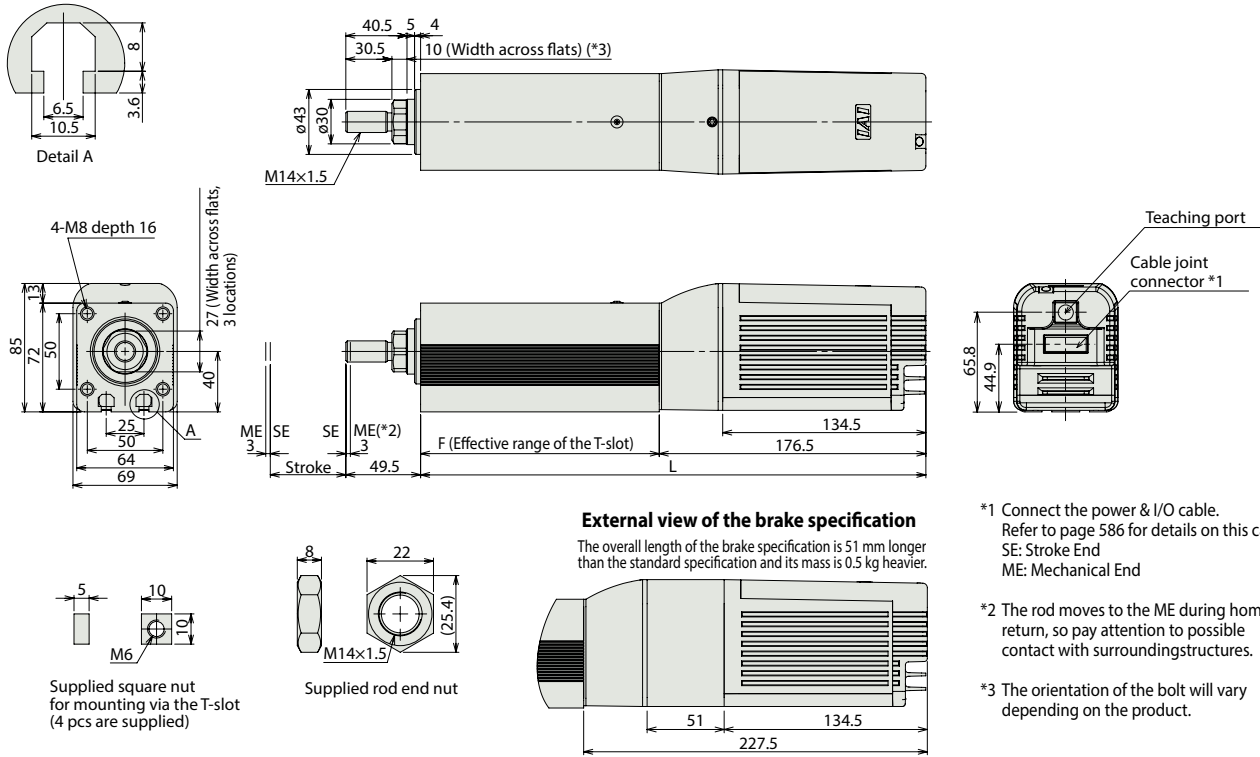

Dimensions and Mass by Stroke

Stroke	50	100	150	200	250	300
L	334.5	384.5	434.5	484.5	534.5	584.5
F	158	208	258	308	358	408
Weight (kg)	3.9	4.4	4.9	5.4	5.9	6.4

Controllers (Built into the Actuator)

I/O type

With the ERC3 series, one of the following five types of built-in controllers can be selected depending on the external input/output (I/O) type. Select the type that meets your purpose.

Name	External view	Model number	Features	Maximum number of positioning points	Input power	Power-supply capacity	Standard price	Reference page
PIO type (NPN specification)		ERC3-RA6C-I-56P-□-□-NP-□-□	Simple control type accommodating up to 16 positioning points	16	DC24V	High-output setting enabled: 3.5A rated 4.2A max. High-output setting disabled: 2.2A	—	→ P577
PIO type (PNP specification)		ERC3-RA6C-I-56P-□-□-PN-□-□	I/O type supporting inputs/outputs of the PNP specification often used overseas	16				
SIO type		ERC3-RA6C-I-56P-□-□-SE-□-□	High-function type accommodating up to 512 positioning points (PIO converter is used)	512				
Pulse-train type (NPN specification)		ERC3-RA6C-I-56P-□-□-PLN-□-□	Pulse-train input type supporting the NPN specification	—				
Pulse-train type (PNP specification)		ERC3-RA6C-I-56P-□-□-PLP-□-□	Pulse-train input type supporting the PNP specification	—				

# ERC2-RA6C

Controller-Integrated, Rod Type, Actuator Width 58mm, Pulse Motor, Straight Type

Model Specification Items	<b>ERC2</b>	<b>RA6C</b>	<b>I</b>	<b>PM</b>	<input type="checkbox"/>	<input type="checkbox"/>	<input type="checkbox"/>	<input type="checkbox"/>	<input type="checkbox"/>
	Series	Type	Encoder type	Motor type	Lead	Stroke	I/O type	Cable length	Options
			I: Incremental	PM: Pulse motor	12: 12mm 6: 6mm 3: 3mm	50: 50mm ? : 300: 300mm (50mm pitch increments)	NP: PIO (NPN) type PN: PIO (PNP) type SE: SIO type	N: None S: 3m X□□: Custom length W□□: Double-ended cable R□□: Robot cable RW□□: Double-ended Robot cable	P: 1m M: 5m B: Brake FT: Foot bracket NM: Non-motor end

\* See page Pre-47 for details on the model descriptions.

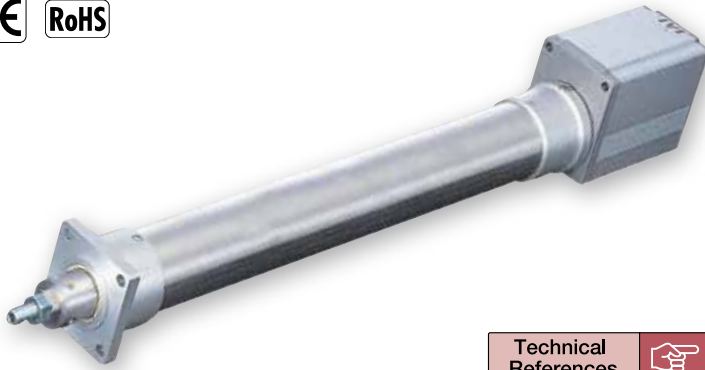

Technical References Appendix P.5

- POINT** Notes on Selection
- (1) When the stroke increases, the maximum speed will drop to prevent the ball screw from reaching the critical rotational speed. Use the actuator specification table below to check the maximum speed at the stroke you desire.
  - (2) Since the ERC2 series use a pulse motor, the load capacity decreases at high speeds. Check in the Speed vs. Load Capacity graph to see if your desired speed and load capacity are supported.
  - (3) The load capacity is based on operation at an acceleration of 0.3G (0.2G for the 3mm-lead model, or when used vertically). This is the upper limit of the acceleration.
  - (4) The value for the horizontal load capacity is with an external guide.
  - (5) See page A-71 for details on push motion.

### Speed vs. Load Capacity

Due to the characteristics of the pulse motor, the ERC2 series' load capacity decreases at high speeds. In the table below, check if your desired speed and load capacity are supported.

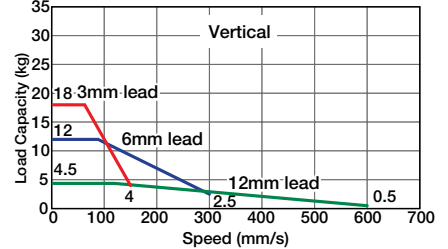
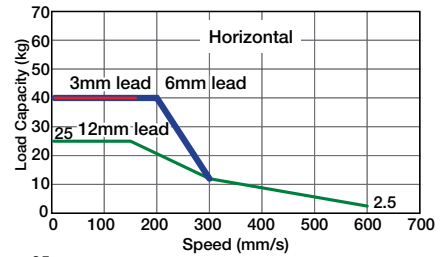

### Actuator Specifications

#### Leads and Payloads

(Note 1) Please note that the maximum load capacity decreases as the speed increases.

Model number	Lead (mm)	Maximum payload (Note 1)		Maximum push force (N)	Stroke (mm)
		Horizontal (kg)	Vertical (kg)		
ERC2-RA6C-I-PM-12-①-②-③-④	12	~25	~4.5	78	50 to 300 (every 50mm)
ERC2-RA6C-I-PM-6-①-②-③-④	6	~40	~12	157	
ERC2-RA6C-I-PM-3-①-②-③-④	3	40	~18	304	

#### Stroke and Maximum Speed

Stroke Lead	50~250 (every 50mm)	300 (mm)
	12	600
6	300	250
3	150	125

(Unit: mm/s)

Code explanation ① Stroke ② I/O type ③ Cable length ④ Options \*See page A-71 for details on push motion.

#### ① Stroke

① Stroke (mm)	Standard price
50	—
100	—
150	—
200	—
250	—
300	—

#### ③ Cable Length

Type	Cable symbol	Standard price
Standard type	P (1m)	—
	S (3m)	—
	M (5m)	—
Special length	X06 (6m) ~ X10 (3m)	—
Double ended	W01 (1m) ~ W03 (5m)	—
	W04 (4m) ~ W05 (10m)	—
	W06 (6m) ~ W10 (10m)	—
Robot cable	R01 (1m) ~ R03 (3m)	—
	R04 (4m) ~ R05 (5m)	—
	R06 (6m) ~ R10 (10m)	—
Double ended Robot cable	RW01 (1m) ~ RW03 (3m)	—
	RW04 (4m) ~ RW05 (5m)	—
	RW06 (6m) ~ RW10 (10m)	—

The values in < > apply to the SE type. \* See page 606 for cables for maintenance.

#### ④ Options

Name	Option code	Page	Standard Price
Brake	B	→ A-42	—
Foot bracket	FT	→ A-47	—
Non-motor end specification	NM	→ A-52	—

### Actuator Specifications

Item	Description
Drive method	Ball screw, ø10mm, rolled C10
Positioning repeatability	±0.02mm
Lost motion	0.1mm or less
Rod diameter	ø22mm special SUS type
Rod non-rotation precision	±1.5 deg
Ambient operating temperature/humidity	0 to 40°C, 85% RH max. (Non-condensing)

- Slider Type
- Mini
- Standard
- Controller Integrated
- Rod Type
- Mini
- Standard
- Controllers Integrated
- Table/Arm/Flat Type
- Mini
- Standard
- Gripper/Rotary Type
- Linear Servo Type
- Clean-room Type
- Splash-Proof Type
- Pulse Motor
- Servo Motor (24V)
- Servo Motor (200V)
- Linear Servo Motor

Dimensional Drawings

CAD drawings can be downloaded from the website. [www.intelligentactuator.com](http://www.intelligentactuator.com)

For Special Orders Appendix P.15



Note:  
Do not apply any external force on the rod from any direction other than the direction of the rod's motion. If a force is exerted on the rod in a perpendicular or rotational direction, the detent may become damaged.

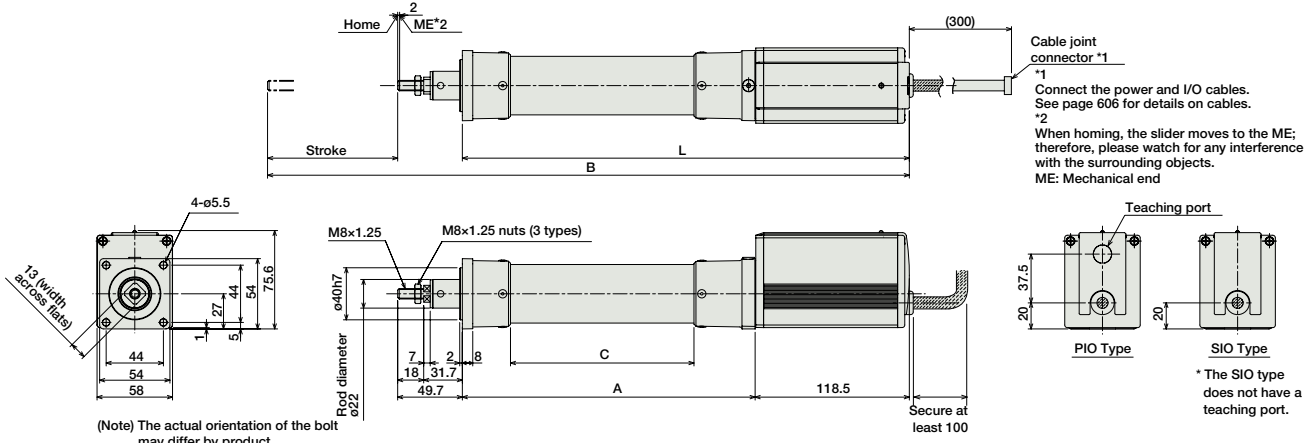

Brake Specifications Diagram

\* Compared to the standard model, the brake-equipped model is longer by 43.5mm and heavier by 0.5kg.

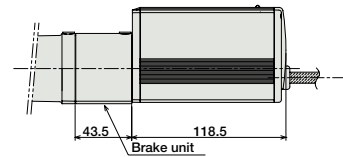

Dimensions and Mass by Stroke

Stroke	50	100	150	200	250	300
L	293.5	343.5	393.5	443.5	493.5	543.5
A	175	225	275	325	375	425
C	91	141	191	241	291	341
Weight (kg)	1.6	1.7	1.8	2.0	2.1	2.2

I/O type (Controller built into the Actuator)

@I/O type

With the ERC2 series, one of the following three types of built-in controllers can be selected depending on the external input/output (I/O) type. Select the type that meets your purpose.

Name	External view	Model number	Features	Maximum number of positioning points	Input power	Power supply capacity	Standard price	Reference page
PIO Type (NPN Specification)		ERC2-RA6C-I-PM-□-□-NP-□-□	Simple control type with up to 16-point positioning	16	DC24V	2A max.	—	→ P597
PIO Type (PNP Specification)		ERC2-RA6C-I-PM-□-□-PN-□-□	Supports the PNP I/O commonly used overseas.	16				
SIO Type		ERC2-RA6C-I-PM-□-□-SE-□-□	Field Network Connection Serial (Gateway unit used)	64				





# ERC2-RA7C

Controller-Integrated, Rod Type, Actuator Width 68mm, Pulse Motor, Straight Type

Model Specification Items

**ERC2 — RA7C** — **I** — **PM** —   —   —   —   —  

Series — Type — Encoder type — Motor type — Lead — Stroke — I/O type — Cable length — Options

I: Incremental PM: Pulse motor 16: 16mm 8: 8mm 4: 4mm 50: 50mm ? 300: 300mm (50mm pitch increments)

NP: PIO (NPN) type PN: PIO (PNP) type SE: SIO type N: None S: 3m P: 1m M: 5m B: Brake FT: Foot bracket NM: Non-motor end X□□: Custom length W□□: Double-ended cable R□□: Robot cable RW□□: Double-ended Robot cable

\* See page Pre-47 for details on the model descriptions.

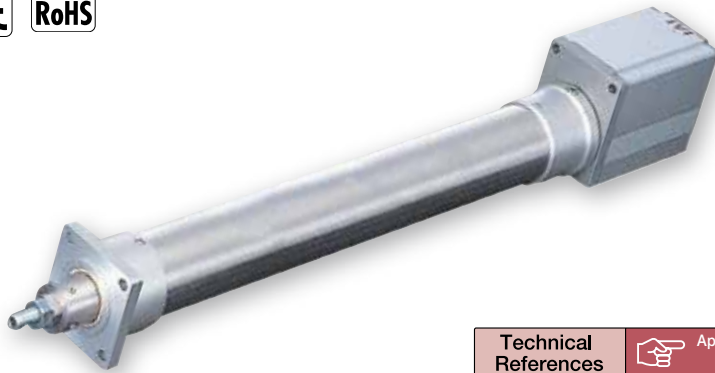

Technical References Appendix P.5



- (1) When the stroke increases, the maximum speed will drop to prevent the ball screw from reaching the critical rotational speed. Use the actuator specification table below to check the maximum speed at the stroke you desire.
- (2) Since the ERC2 series use a pulse motor, the load capacity decreases at high speeds. Check in the Speed vs. Load Capacity graph to see if your desired speed and load capacity are supported.
- (3) The load capacity is based on operation at an acceleration of 0.3G (0.2G for the 4mm-lead model, or when used vertically). This is the upper limit of the acceleration.
- (4) The value for the horizontal load capacity is with an external guide.
- (5) See page A-71 for details on push motion.

### Speed vs. Load Capacity

Due to the characteristics of the pulse motor, the ERC2 series' load capacity decreases at high speeds. In the table below, check if your desired speed and load capacity are supported.

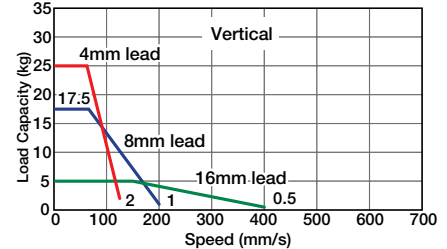
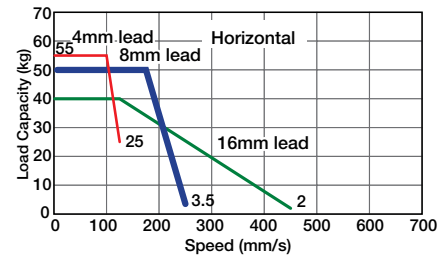

### Actuator Specifications

#### Leads and Payloads

(Note 1) Please note that the maximum load capacity decreases as the speed increases.

Model number	Lead (mm)	Maximum payload (Note 1)		Maximum push force (N)	Stroke (mm)
		Horizontal (kg)	Vertical (kg)		
ERC2-RA7C-I-PM-16-①-②-③-④	16	~40	~5	220	50 to 300 (every 50mm)
ERC2-RA7C-I-PM-8-①-②-③-④	8	~50	~17.5	441	
ERC2-RA7C-I-PM-4-①-②-③-④	4	~55	~25	873	

Code explanation ① Stroke ② I/O type ③ Cable length ④ Options \*See page A-71 for details on push motion.

#### Stroke and Maximum Speed

Stroke / Lead	50~300 (every 50mm)
16	450 <400>
8	250 <200>
4	125

\* The values enclosed in < > apply to vertical settings. (Unit: mm/s)

#### ① Stroke

① Stroke (mm)	Standard price
50	—
100	—
150	—
200	—
250	—
300	—

#### ③ Cable Length

Type	Cable symbol	Standard price
Standard type	P (1m)	—
	S (3m)	—
	M (5m)	—
Special length	X06 (6m) ~ X10 (3m)	—
Double ended	W01 (1m) ~ W03 (5m)	—
	W04 (4m) ~ W05 (10m)	—
	W06 (6m) ~ W10 (10m)	—
Robot cable	R01 (1m) ~ R03 (3m)	—
	R04 (4m) ~ R05 (5m)	—
	R06 (6m) ~ R10 (10m)	—
Double ended Robot cable	RW01 (1m) ~ RW03 (3m)	—
	RW04 (4m) ~ RW05 (5m)	—
	RW06 (6m) ~ RW10 (10m)	—

The values in < > apply to the SE type.

\* See page 606 for cables for maintenance.

#### ④ Options

Name	Option code	Page	Standard Price
Brake	B	→ A-42	—
Foot bracket	FT	→ A-47	—
Non-motor end specification	NM	→ A-52	—

### Actuator Specifications

Item	Description
Drive method	Ball screw, ø12mm, rolled C10
Positioning repeatability	±0.02mm
Lost motion	0.1mm or less
Rod diameter	ø30mm special SUS type
Rod non-rotation precision	±1.5 deg
Ambient operating temperature/humidity	0 to 40°C, 85% RH max. (Non-condensing)

Dimensional Drawings

CAD drawings can be downloaded from the website. [www.intelligentactuator.com](http://www.intelligentactuator.com)



Note:  
Do not apply any external force on the rod from any direction other than the direction of the rod's motion. If a force is exerted on the rod in a perpendicular or rotational direction, the detent may become damaged.

For Special Orders Appendix P.15

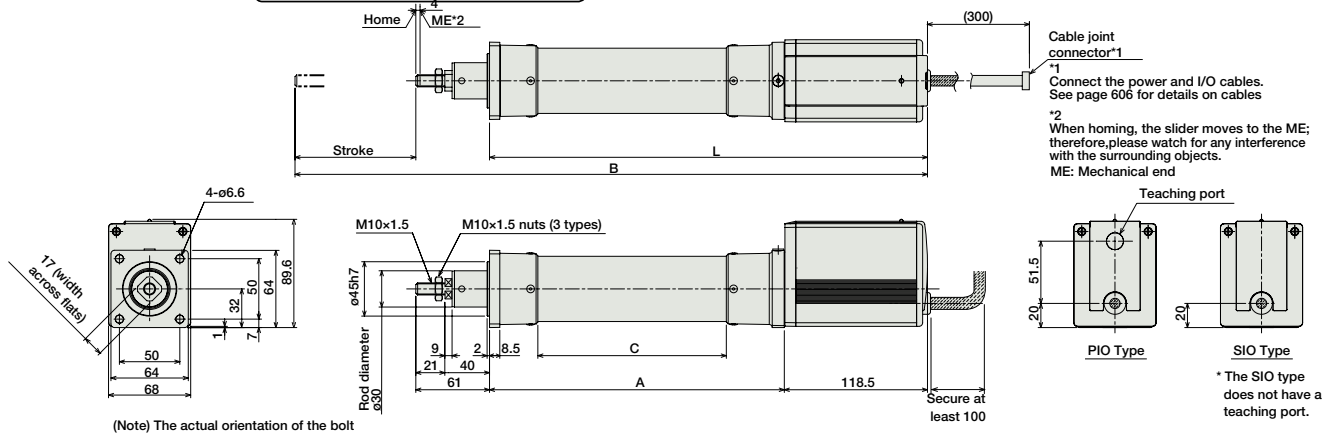

(Note) The actual orientation of the bolt may differ by product.

Brake Specifications Diagram

\* Compared to the standard model, the brake-equipped model is longer by 49mm and heavier by 0.5kg.

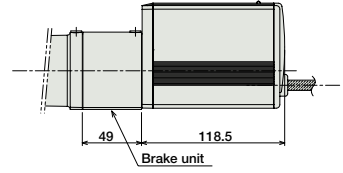

Dimensions and Mass by Stroke

Stroke	50	100	150	200	250	300
L	312.5	362.5	412.5	462.5	512.5	562.5
A	194	244	294	344	394	444
C	106	156	206	256	306	356
Weight (kg)	2.7	2.9	3.0	3.2	3.3	3.5

I/O type (Controller built into the Actuator)

@I/O type

With the ERC2 series, one of the following three types of built-in controllers can be selected depending on the external input/output (I/O) type. Select the type that meets your purpose.

Name	External view	Model number	Features	Maximum number of positioning points	Input power	Power supply capacity	Standard price	Reference page
PIO Type (NPN Specification)		ERC2-RA7C-I-PM-□-□-NP-□-□	Simple control type with up to 16-point positioning	16	DC24V	2A max.	—	→ P597
PIO Type (PNP Specification)		ERC2-RA7C-I-PM-□-□-PN-□-□	Supports the PNP I/O commonly used overseas.	16				
SIO Type		ERC2-RA7C-I-PM-□-□-SE-□-□	Field Network Connection Serial (Gateway unit used)	64				

- Slider Type
- Mini
- Standard
- Controller Integrated
- Rod Type
- Mini
- Standard
- Controllers Integrated
- Table/Arm/Flat Type
- Mini
- Standard
- Gripper/Rotary Type
- Linear Servo Type
- Clean-room Type
- Splash-Proof Type
- Pulse Motor
- Servo Motor (24V)
- Servo Motor (200V)
- Linear Servo Motor

# ERC2-RGS6C

Controller-integrated, Rod Type with Single Guide, Actuator Width 58mm, Pulse Motor, Straight Type

Model Specification Items	<b>ERC2</b>	<b>RA6C</b>	<b>I</b>	<b>PM</b>	<input type="checkbox"/>	<input type="checkbox"/>	<input type="checkbox"/>	<input type="checkbox"/>	<input type="checkbox"/>
	Series	Type	Encoder type	Motor type	Lead	Stroke	I/O type	Cable length	Options
			I: Incremental	PM: Pulse motor	12: 12mm 6: 6mm 3: 3mm	50: 50mm ? 300: 300mm (50mm pitch increments)	NP: PLO (NPN) type PN: PLO (PNP) type SE: SIO type	N: None S: 3m X: Custom length W: Double-ended cable R: Robot cable RW: Double-ended Robot cable	P: 1m M: 5m Custom length NM: Non-motor end

\* See page Pre-47 for details on the model descriptions.

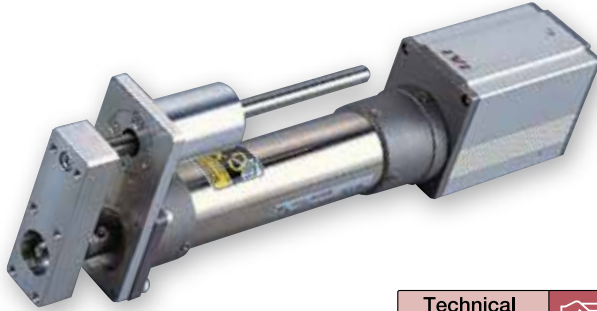

Technical References Appendix P.5

- POINT** Notes on Selection
- When the stroke increases, the maximum speed will drop to prevent the ball screw from reaching the critical rotational speed. Use the actuator specification table below to check the maximum speed at the stroke you desire.
  - Since the ERC2 series use a pulse motor, the load capacity decreases at high speeds. Check in the Speed vs. Load Capacity graph to see if your desired speed and load capacity are supported.
  - The load capacity is based on operation at an acceleration of 0.3G (0.2G for the 3mm-lead model, or when used vertically). This is the upper limit of the acceleration.
  - The value for the horizontal load capacity is with an external guide.
  - See page A-71 for details on push motion.

### Speed vs. Load Capacity

Due to the characteristics of the pulse motor, the ERC2 series' load capacity decreases at high speeds. In the table below, check if your desired speed and load capacity are supported.

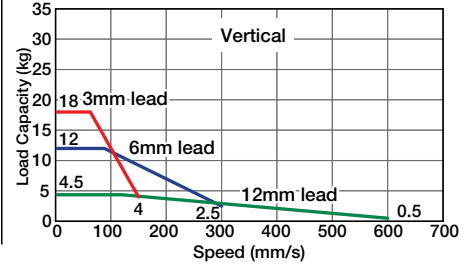
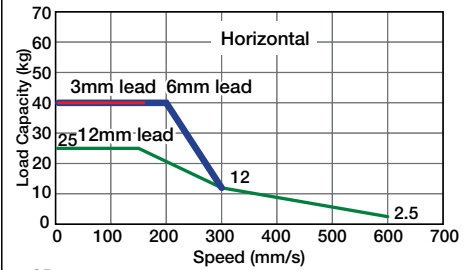

### Actuator Specifications

#### Leads and Payloads

(Note 1) Please note that the maximum load capacity decreases as the speed increases.

Model number	Lead (mm)	Maximum payload (Note 1)		Maximum push force (N)	Stroke (mm)
		Horizontal (kg)	Vertical (kg)		
ERC2-RGS6C-I-PM-12-①-②-③-④	12	~25	~4.5	78	50 to 300 (every 50mm)
ERC2-RGS6C-I-PM-6-①-②-③-④	6	~40	~12	157	
ERC2-RGS6C-I-PM-3-①-②-③-④	3	40	~18	304	

#### Stroke and Maximum Speed

Stroke Lead	50~250 (every 50mm)	300 (mm)
12	600	500
6	300	250
3	150	125

Code explanation ① Stroke ② I/O type ③ Cable length ④ Options \*See page A-71 for details on push motion.

(Unit: mm/s)

#### ① Stroke

① Stroke (mm)	Standard price
50	—
100	—
150	—
200	—
250	—
300	—

#### ③ Cable Length

Type	Cable symbol	Standard price
Standard type	P (1m)	—
	S (3m)	—
	M (5m)	—
Special length	X06 (6m) ~ X10 (3m)	—
Double ended	W01 (1m) ~ W03 (5m)	—
	W04 (4m) ~ W05 (10m)	—
	W06 (6m) ~ W10 (10m)	—
	R01 (1m) ~ R03 (3m)	—
Robot cable	R04 (4m) ~ R05 (5m)	—
	R06 (6m) ~ R10 (10m)	—
	RW01 (1m) ~ RW03 (3m)	—
Double ended Robot cable	RW04 (4m) ~ RW05 (5m)	—
	RW06 (6m) ~ RW10 (10m)	—

The values in < > apply to the SE type. \* See page 606 for cables for maintenance.

#### ④ Options

Name	Option code	Page	Standard Price
Brake	B	→ A-42	—
Foot bracket	FT	→ A-47	—
Non-motor end specification	NM	→ A-52	—

### Actuator Specifications

Item	Description
Drive method	Ball screw, ø10mm, rolled C10
Positioning repeatability	±0.02mm
Lost motion	0.1mm or less
Rod diameter	ø22mm special SUS type
Rod non-rotation precision	±1.5 deg
Ambient operating temperature/humidity	0 to 40°C, 85% RH max. (Non-condensing)

Dimensional Drawings

CAD drawings can be downloaded from the website. [www.intelligentactuator.com](http://www.intelligentactuator.com)

For Special Orders Appendix P.15

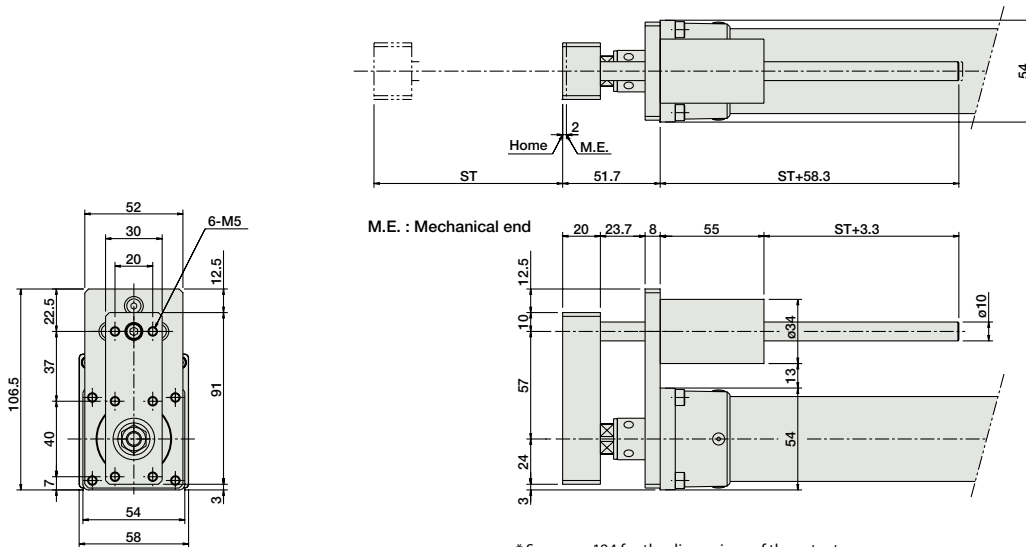

\* See page 184 for the dimensions of the actuator.

Dimensions and Mass by Stroke

Stroke	50	100	150	200	250	300
Guide weight (kg)	0.2	0.2	0.3	0.3	0.3	0.4
Guide + actuator weight (kg)	1.8	1.9	2.1	2.3	2.4	2.6

I/O type (Controller built into the Actuator)

I/O type

With the ERC2 series, one of the following three types of built-in controllers can be selected depending on the external input/output (I/O) type. Select the type that meets your purpose.

Name	External view	Model number	Features	Maximum number of positioning points	Input power	Power supply capacity	Standard price	Reference page
PIO Type (NPN Specification)		ERC2-RGS6C-I-PM-□-□-NP-□-□	Simple control type with up to 16-point positioning	16	DC24V	2A max.	—	→ P597
PIO Type (PNP Specification)		ERC2-RGS6C-I-PM-□-□-PN-□-□	Supports the PNP I/O commonly used overseas.	16				
SIO Type		ERC2-RGS6C-I-PM-□-□-SE-□-□	Field Network Connection Serial (Gateway unit used)	64				

- Slider Type
- Mini
- Standard
- Controllers Integrated
- Rod Type
- Mini
- Standard
- Controllers Integrated
- Table/ Arm/ Flat Type
- Mini
- Standard
- Gripper/ Rotary Type
- Linear Servo Type
- Clean-room Type
- Splash-Proof Type
- Pulse Motor
- Servo Motor (24V)
- Servo Motor (200V)
- Linear Servo Motor

# ERC2-RGS7C

Controller-integrated, Rod Type with Single Guide, Actuator Width 68mm, Pulse Motor, Straight Type

Model Specification Items	<b>ERC2</b>	<b>RGS7C</b>	<b>I</b>	<b>PM</b>	<input type="checkbox"/>	<input type="checkbox"/>	<input type="checkbox"/>	<input type="checkbox"/>	<input type="checkbox"/>
	Series	Type	Encoder type	Motor type	Lead	Stroke	I/O type	Cable length	Options
			I: Incremental	PM: Pulse motor	16: 16mm 8: 8mm 4: 4mm	50: 50mm ? : 300: 300mm (50mm pitch increments)	NP: PIO (NPN) type PN: PIO (PNP) type SE: SIO type	N: None S: 3m M: 5m X□□: Custom length W□□: Double-ended cable R□□: Robot cable RW□□: Double-ended Robot cable	B : Brake FT : Foot bracket NM : Non-motor end

\* See page Pre-47 for details on the model descriptions.

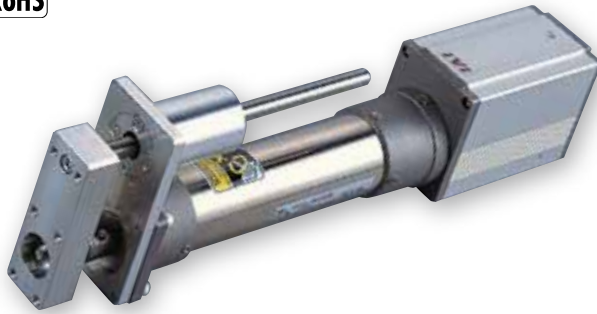

Technical References Appendix P.5

- POINT**  
Notes on Selection
- When the stroke increases, the maximum speed will drop to prevent the ball screw from reaching the critical rotational speed. Use the actuator specification table below to check the maximum speed at the stroke you desire.
  - Since the ERC2 series use a pulse motor, the load capacity decreases at high speeds. Check in the Speed vs. Load Capacity graph to see if your desired speed and load capacity are supported.
  - The load capacity is based on operation at an acceleration of 0.3G (0.2G for the 4mm-lead model, or when used vertically). This is the upper limit of the acceleration.
  - The value for the horizontal load capacity is with an external guide.
  - See page A-71 for details on push motion.

### Speed vs. Load Capacity

Due to the characteristics of the pulse motor, the ERC2 series' load capacity decreases at high speeds. In the table below, check if your desired speed and load capacity are supported.

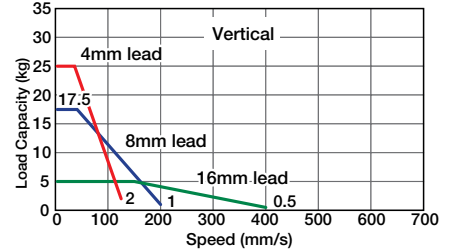
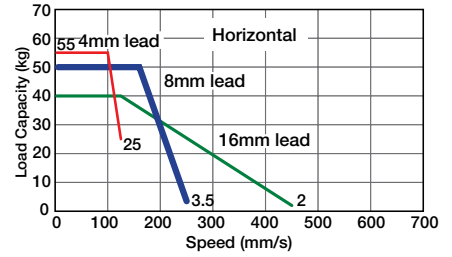

### Actuator Specifications

#### Leads and Payloads

(Note 1) Please note that the maximum load capacity decreases as the speed increases.

Model number	Lead (mm)	Maximum payload (Note 1)		Maximum push force (N)	Stroke (mm)
		Horizontal (kg)	Vertical (kg)		
ERC2-RGS7C-I-PM-16-①-②-③-④	16	~40	~5	220	50 to 300 (every 50mm)
ERC2-RGS7C-I-PM-8-①-②-③-④	8	~50	~17.5	441	
ERC2-RGS7C-I-PM-4-①-②-③-④	4	~55	~25	873	

Code explanation ① Stroke ② I/O type ③ Cable length ④ Options \*See page A-71 for details on push motion.

#### Stroke and Maximum Speed

Stroke / Lead	50~250 (every 50mm)
16	450 <400>
8	250 <200>
4	125

\*The values enclosed in < > apply to vertical settings. (Unit: mm/s)

#### ① Stroke

① Stroke (mm)	Standard price
50	—
100	—
150	—
200	—
250	—
300	—

#### ③ Cable Length

Type	Cable symbol	Standard price
Standard type	P (1m)	—
	S (3m)	—
	M (5m)	—
Special length	X06 (6m) ~ X10 (3m)	—
Double ended	W01 (1m) ~ W03 (5m)	—
	W04 (4m) ~ W05 (10m)	—
	W06 (6m) ~ W10 (10m)	—
	R01 (1m) ~ R03 (3m)	—
Robot cable	R04 (4m) ~ R05 (5m)	—
	R06 (6m) ~ R10 (10m)	—
	RW01 (1m) ~ RW03 (3m)	—
Double ended Robot cable	RW04 (4m) ~ RW05 (5m)	—
	RW06 (6m) ~ RW10 (10m)	—

The values in < > apply to the SE type. \* See page 606 for cables for maintenance.

#### ④ Options

Name	Option code	Page	Standard Price
Brake	B	→ A-42	—
Foot bracket	FT	→ A-47	—
Non-motor end specification	NM	→ A-52	—

### Actuator Specifications

Item	Description
Drive method	Ball screw, ø12mm, rolled C10
Positioning repeatability	±0.02mm
Lost motion	0.1mm or less
Rod diameter	ø30mm special SUS type
Rod non-rotation precision	±0.05 deg
Ambient operating temperature/humidity	0 to 40°C, 85% RH max. (Non-condensing)

Dimensional Drawings

CAD drawings can be downloaded from the website. [www.intelligentactuator.com](http://www.intelligentactuator.com)

For Special Orders  Appendix P.15

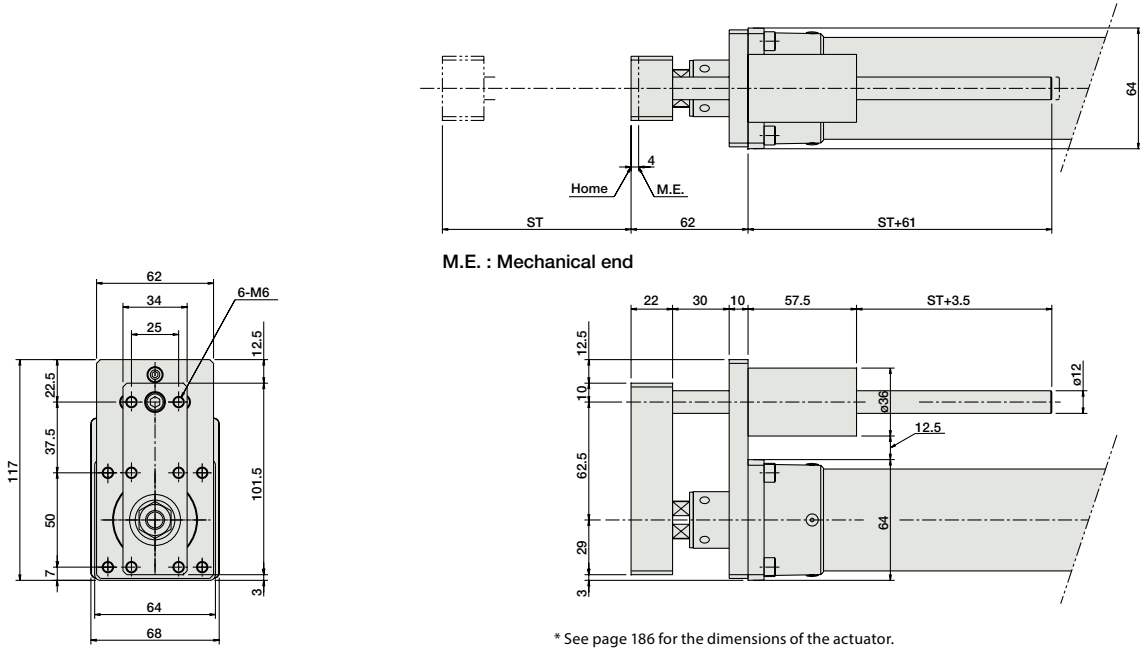



■ Dimensions and Mass by Stroke

Stroke	50	100	150	200	250	300
Guide weight (kg)	0.3	0.3	0.4	0.4	0.5	0.5
Guide + actuator weight (kg)	3.0	3.2	3.4	3.6	3.8	4.0

I/O type (Controller built into the Actuator)

@I/O type

With the ERC2 series, one of the following three types of built-in controllers can be selected depending on the external input/output (I/O) type. Select the type that meets your purpose.

Name	External view	Model number	Features	Maximum number of positioning points	Input power	Power supply capacity	Standard price	Reference page
PIO Type (NPN Specification)		ERC2-RGS7C-I-PM-□-□-NP-□-□	Simple control type with up to 16-point positioning	16	DC24V	2A max.	—	→ P597
PIO Type (PNP Specification)		ERC2-RGS7C-I-PM-□-□-PN-□-□	Supports the PNP I/O commonly used overseas.	16				
SIO Type		ERC2-RGS7C-I-PM-□-□-SE-□-□	Field Network Connection Serial (Gateway unit used)	64				

- Slider Type
- Mini
- Standard
- Controllers Integrated
- Rod Type
- Mini
- Standard
- Controllers Integrated
- Table/ Arm/ Flat Type
- Mini
- Standard
- Gripper/ Rotary Type
- Linear Servo Type
- Clean-room Type
- Splash-Proof Type
- Pulse Motor
- Servo Motor (24V)
- Servo Motor (200V)
- Linear Servo Motor

# ERC2-RGD6C

Controller-integrated, Rod Type with Double Guide, Actuator Width 58mm, Pulse Motor, Straight Type

Model Specification Items	<b>ERC2</b>	<b>RGD6C</b>	<b>I</b>	<b>PM</b>	<input type="checkbox"/>	<input type="checkbox"/>	<input type="checkbox"/>	<input type="checkbox"/>	<input type="checkbox"/>
	Series	Type	Encoder type	Motor type	Lead	Stroke	I/O type	Cable length	Options
			I: Incremental	PM: Pulse motor	12: 12mm 6: 6mm 3: 3mm	50: 50mm ? : 300: 300mm (50mm pitch increments)	NP: P/O (NPN) type PN: P/O (PNP) type SE: S/O type	N: None S: 3m X: Custom length W: Double-ended cable R: Robot cable RW: Double-ended Robot cable	P: 1m M: 5m FT: Foot bracket NM: Non-motor end B: Brake

\* See page Pre-47 for details on the model descriptions.

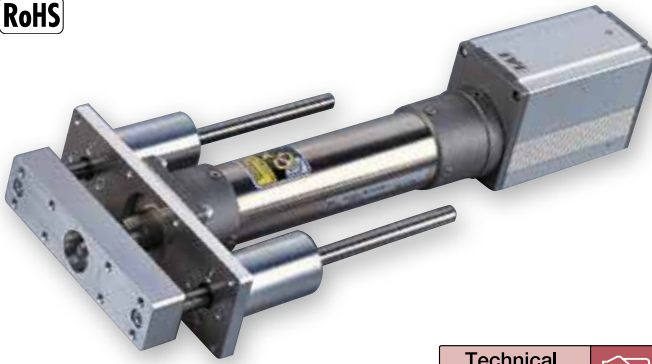

Technical References Appendix P.5

- POINT** Notes on Selection
- (1) When the stroke increases, the maximum speed will drop to prevent the ball screw from reaching the critical rotational speed. Use the actuator specification table below to check the maximum speed at the stroke you desire.
  - (2) Since the ERC2 series use a pulse motor, the load capacity decreases at high speeds. Check in the Speed vs. Load Capacity graph to see if your desired speed and load capacity are supported.
  - (3) The load capacity is based on operation at an acceleration of 0.3G (0.2G for the 3mm-lead model, or when used vertically). This is the upper limit of the acceleration.
  - (4) The value for the horizontal load capacity is with an external guide.
  - (5) See page A-71 for details on push motion.

### Speed vs. Load Capacity

Due to the characteristics of the pulse motor, the ERC2 series' load capacity decreases at high speeds. In the table below, check if your desired speed and load capacity are supported.

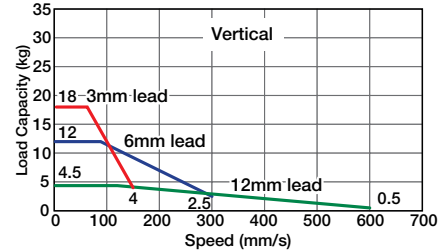
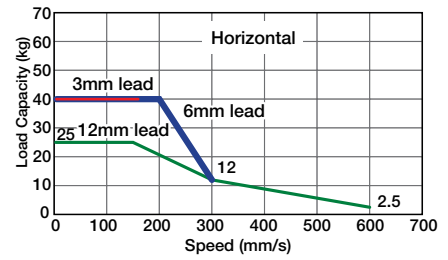

### Actuator Specifications

#### Leads and Payloads

(Note 1) Please note that the maximum load capacity decreases as the speed increases.

Model number	Lead (mm)	Maximum payload (Note 1)		Maximum push force (N)	Stroke (mm)
		Horizontal (kg)	Vertical (kg)		
ERC2-RGD6C-I-PM-12-①-②-③-④	12	~25	~4.5	78	50 to 300 (every 50mm)
ERC2-RGD6C-I-PM-6-①-②-③-④	6	~40	~12	157	
ERC2-RGD6C-I-PM-3-①-②-③-④	3	40	~18	304	

Code explanation ① Stroke ② I/O type ③ Cable length ④ Options \*See page A-71 for details on push motion.

#### Stroke and Maximum Speed

Stroke / Lead	50~250 (every 50mm)	300 (mm)
	12	600
6	300	250
3	150	125

(Unit: mm/s)

#### ① Stroke

Stroke (mm)	Standard price
50	—
100	—
150	—
200	—
250	—
300	—

#### ③ Cable Length

Type	Cable symbol	Standard price
Standard type	P (1m)	—
	S (3m)	—
	M (5m)	—
Special length	X06 (6m) ~ X10 (3m)	—
Double ended	W01 (1m) ~ W03 (5m)	—
	W04 (4m) ~ W05 (10m)	—
	W06 (6m) ~ W10 (10m)	—
Robot cable	R01 (1m) ~ R03 (3m)	—
	R04 (4m) ~ R05 (5m)	—
	R06 (6m) ~ R10 (10m)	—
Double ended Robot cable	RW01 (1m) ~ RW03 (3m)	—
	RW04 (4m) ~ RW05 (5m)	—
	RW06 (6m) ~ RW10 (10m)	—

The values in < > apply to the SE type. \* See page 606 for cables for maintenance.

#### ④ Options

Name	Option code	Page	Standard Price
Brake	B	→ A-42	—
Foot bracket	FT	→ A-47	—
Non-motor end specification	NM	→ A-52	—

### Actuator Specifications

Item	Description
Drive method	Ball screw, ø10mm, rolled C10
Positioning repeatability	±0.02mm
Lost motion	0.1mm or less
Rod diameter	ø22mm special SUS type
Rod non-rotation precision	±0.05 deg
Ambient operating temperature/humidity	0 to 40°C, 85% RH max. (Non-condensing)

Dimensional Drawings

CAD drawings can be downloaded from the website. [www.intelligentactuator.com](http://www.intelligentactuator.com)

For Special Orders

Appendix P.15

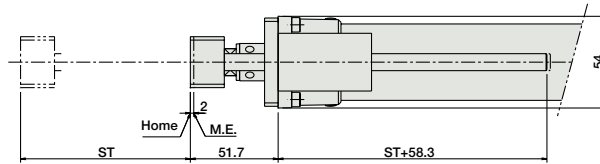
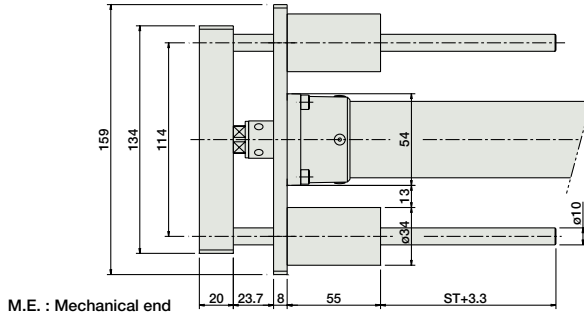
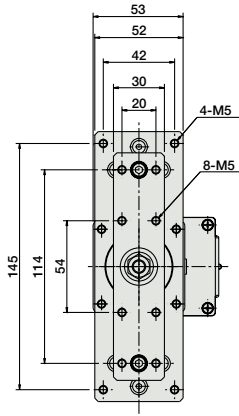

\* See page 184 for the dimensions of the actuator.

Dimensions and Mass by Stroke

Stroke	50	100	150	200	250	300
Guide weight (kg)	0.4	0.4	0.5	0.6	0.6	0.7
Guide + actuator weight (kg)	2.0	2.1	2.3	2.6	2.7	2.9

I/O type (Controller built into the Actuator)

@I/O type

With the ERC2 series, one of the following three types of built-in controllers can be selected depending on the external input/output (I/O) type. Select the type that meets your purpose.

Name	External view	Model number	Features	Maximum number of positioning points	Input power	Power supply capacity	Standard price	Reference page
PIO Type (NPN Specification)		ERC2-RGD6C-I-PM-□-□-NP-□-□	Simple control type with up to 16-point positioning	16	DC24V	2A max.	—	→ P597
PIO Type (PNP Specification)		ERC2-RGD6C-I-PM-□-□-PN-□-□	Supports the PNP I/O commonly used overseas.	16				
SIO Type		ERC2-RGD6C-I-PM-□-□-SE-□-□	Field Network Connection Serial (Gateway unit used)	64				



# ERC2-RGD7C

Controller-integrated, Rod Type with Double Guide, Actuator Width 68mm, Pulse Motor, Straight Type

Model Specification Items

<b>ERC2</b>	<b>RGD7C</b>	<b>I</b>	<b>PM</b>						
Series	Type	Encoder type	Motor type	Lead	Stroke	I/O type	Cable length	Options	
		I: Incremental	PM: Pulse motor	16: 16mm 8: 8mm 4: 4mm	50: 50mm ? : 300: 300mm (50mm pitch increments)	NP: PLO (NPN) type PN: PLO (PNP) type SE: SIO type	N : None S : 3m M : 5m X□□ : Custom W□□ : Double-ended cable R□□ : Robot cable RW□□ : Double-ended Robot cable	P : 1m M : 5m	See Options below.

\* See page Pre-47 for details on the model descriptions.

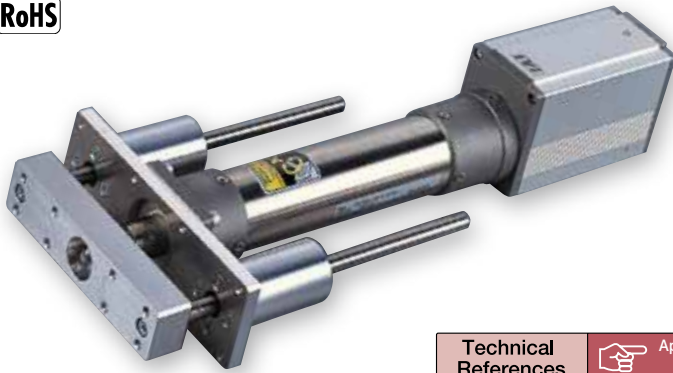

Technical References Appendix P.5

- POINT** Notes on Selection
- (1) When the stroke increases, the maximum speed will drop to prevent the ball screw from reaching the critical rotational speed. Use the actuator specification table below to check the maximum speed at the stroke you desire.
  - (2) Since the ERC2 series use a pulse motor, the load capacity decreases at high speeds. Check in the Speed vs. Load Capacity graph to see if your desired speed and load capacity are supported.
  - (3) The load capacity is based on operation at an acceleration of 0.3G (0.2G for the 4mm-lead model, or when used vertically). This is the upper limit of the acceleration.
  - (4) The value for the horizontal load capacity is with an external guide.
  - (5) See page A-71 for details on push motion.

**Speed vs. Load Capacity**

Due to the characteristics of the pulse motor, the ERC2 series' load capacity decreases at high speeds. In the table below, check if your desired speed and load capacity are supported.

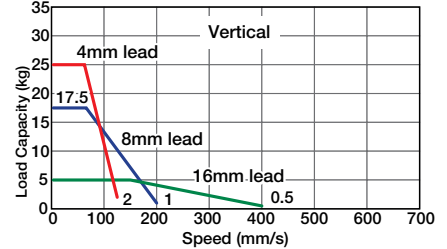
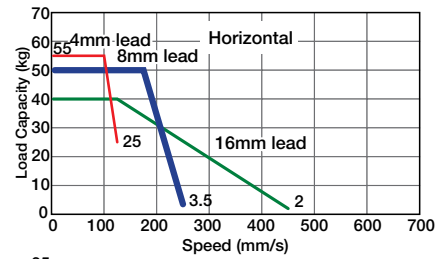

**Actuator Specifications**

**Leads and Payloads**

(Note 1) Please note that the maximum load capacity decreases as the speed increases.

Model number	Lead (mm)	Maximum payload (Note 1)		Maximum push force (N)	Stroke (mm)
		Horizontal (kg)	Vertical (kg)		
ERC2-RGD7C-I-PM-16-①-②-③-④	16	~40	~5	220	50 to 300 (every 50mm)
ERC2-RGD7C-I-PM-8-①-②-③-④	8	~50	~17.5	441	
ERC2-RGS7C-I-PM-4-①-②-③-④	4	~55	~25	873	

**Stroke and Maximum Speed**

Stroke Lead	50~300 (every 50mm)
16	450 <400>
8	250 <200>
4	125

Code explanation ① Stroke ② I/O type ③ Cable length ④ Options \*See page A-71 for details on push motion. (Unit: mm/s)

**① Stroke**

Stroke (mm)	Standard price
50	—
100	—
150	—
200	—
250	—
300	—

**③ Cable Length**

Type	Cable symbol	Standard price
Standard type	P (1m)	—
	S (3m)	—
	M (5m)	—
Special length	X06 (6m) ~ X10 (3m)	—
Double ended	W01 (1m) ~ W03 (5m)	—
	W04 (4m) ~ W05 (10m)	—
	W06 (6m) ~ W10 (10m)	—
Robot cable	R01 (1m) ~ R03 (3m)	—
	R04 (4m) ~ R05 (5m)	—
	R06 (6m) ~ R10 (10m)	—
Double ended Robot cable	RW01 (1m) ~ RW03 (3m)	—
	RW04 (4m) ~ RW05 (5m)	—
	RW06 (6m) ~ RW10 (10m)	—

The values in < > apply to the SE type. \* See page 606 for cables for maintenance.

**④ Options**

Name	Option code	Page	Standard Price
Brake	B	→ A-42	—
Foot bracket	FT	→ A-47	—
Non-motor end specification	NM	→ A-52	—

**Actuator Specifications**

Item	Description
Drive method	Ball screw, ø12mm, rolled C10
Positioning repeatability	±0.02mm
Lost motion	0.1mm or less
Rod diameter	ø30mm special SUS type
Rod non-rotation precision	±0.05 deg
Ambient operating temperature/humidity	0 to 40°C, 85% RH max. (Non-condensing)

Dimensional Drawings

CAD drawings can be downloaded from the website. [www.intelligentactuator.com](http://www.intelligentactuator.com)

For Special Orders Appendix P.15

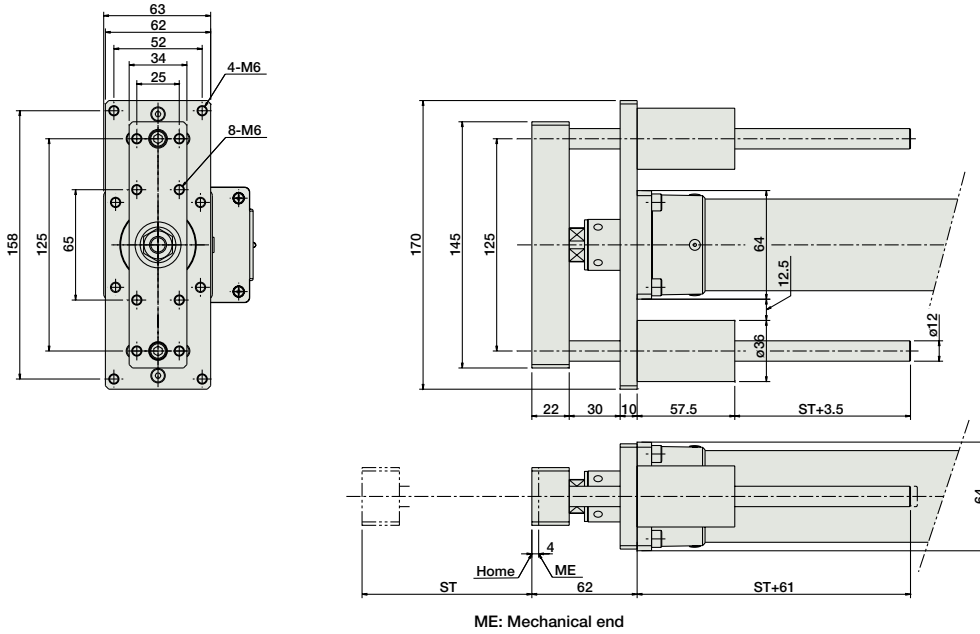

\* See page 186 for the dimensions of the actuator.

Dimensions and Mass by Stroke

Stroke	50	100	150	200	250	300
Guide weight (kg)	0.5	0.6	0.7	0.8	0.9	1.0
Guide + actuator weight (kg)	3.2	3.5	3.7	4.0	4.2	4.5

I/O type (Controller built into the Actuator)

@I/O type

With the ERC2 series, one of the following three types of built-in controllers can be selected depending on the external input/output (I/O) type. Select the type that meets your purpose.

Name	External view	Model number	Features	Maximum number of positioning points	Input power	Power supply capacity	Standard price	Reference page
PIO Type (NPN Specification)		ERC2-RGD7C-I-PM-□-□-NP-□-□	Simple control type with up to 16-point positioning	16	DC24V	2A max.	—	→ P597
PIO Type (PNP Specification)		ERC2-RGD7C-I-PM-□-□-PN-□-□	Supports the PNP I/O commonly used overseas.	16				
SIO Type		ERC2-RGD7C-I-PM-□-□-SE-□-□	Field Network Connection Serial (Gateway unit used)	64				

- Slider Type
- Mini
- Standard
- Controllers Integrated
- Rod Type
- Mini
- Standard
- Controllers Integrated
- Table/ Arm/ Flat Type
- Mini
- Standard
- Gripper/ Rotary Type
- Linear Servo Type
- Clean-room Type
- Splash-Proof Type
- Pulse Motor
- Servo Motor (24V)
- Servo Motor (200V)
- Linear Servo Motor

# RCD-RA1DA

ROBO Cylinder, Ultra-Compact Rod Type, Actuator Width 12mm, DC24V Brushless Motor

Model Specification Items

**RCD** — **RA1DA** — **I** — **3** — **2** —  — **D3** —

Series — Type — Encoder type — Motor type — Lead — Stroke — Applicable Controller — Cable length

I: Incremental 3: DC Brushless Motor 2.5W 2: 2mm 10: 10mm ? 30: 30mm (Every 10mm) D3: DSEP N: None P: 1m S: 3m M: 5m X: Custom length R: Robot cable

\* See page Pre-47 for details on the model descriptions.



Technical References Appendix P.5



- (1) The load capacity is based on operation at an acceleration of 1G. This is the upper limit of the acceleration/deceleration speed.
- (2) The horizontal payload is the value when used in combination with an external guide. Please note that if an external force is applied to the rod in a direction other than the proper direction the rod travels, the detent may get damaged.
- (3) The push motion is when operated at 5mm/s.
- (4) Since this model uses a lead screw, the actuator specifications may change according to the usage.
- (5) Take note that, since there is no brake, the rod may come down when the power is turned off if the actuator is used vertically.
- (6) See page A-71 for details on push motion.

### Electric Current Limit and Pushing Force

#### Electric current limit and pushing force

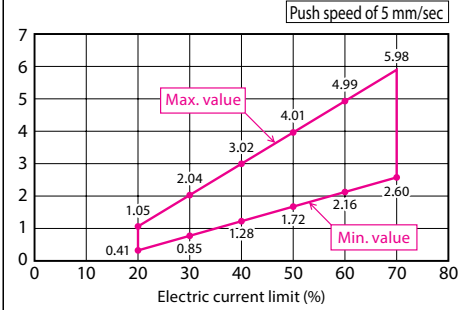

\* The ranges shown in this graph take into account efficiency deterioration caused by wear on the lead screw. Always use the product within the maximum and minimum values.

### Actuator Specifications

#### Lead and Payloads

Model number	Motor output (W)	Feed Screw	Lead (mm)	Maximum payload		Maximum push force (N)	Stroke (mm)
				Horizontal (kg)	Vertical (kg)		
RCD-RA1DA-I-3-2-①-D3-②	2.5	Lead screw	2	0.7	0.3	4.2	10 to 30 (every 10 mm)

#### Stroke and Maximum Speed

Lead (mm)	10~30 (every 10mm)
2	300

Legend ① Stroke ② Cable length \*See page A-71 for details on push motion. (Unit: mm/s)

#### ① Stroke

Stroke (mm)	Standard price
10	—
20	—
30	—

#### ② Cable Length

Type	Cable symbol	Standard price
Standard type	P (1m)	—
	S (3m)	—
	M (5m)	—
Special length	X06 (6m) ~ X10 (10m)	—
	X11 (11m) ~ X15 (15m)	—
	X16 (16m) ~ X20 (20m)	—
Robot cable	R01 (1m) ~ R03 (3m)	—
	R04 (4m) ~ R05 (5m)	—
	R06 (6m) ~ R10 (10m)	—
	R11 (11m) ~ R15 (15m)	—
	R16 (16m) ~ R20 (20m)	—

\* See page A-59 for cables for maintenance.

### Actuator Specifications

Item	Description
Drive method	Ball screw, ø3mm
Positioning repeatability	±0.05mm
Lost motion	0.2mm or less
Encoder resolution	400 pulses/rev
Base	Material: Aluminum, white alumite treated
Allowable static moment	0.02 N·m
Rod non-rotation precision	±3 deg
Ambient operating temperature/humidity	0 to 40°C, 85% RH max. (Non-condensing)
Service life	10 million cycles (for horizontal and vertical)

Dimensional Drawings

CAD drawings can be downloaded from the website. [www.intelligentactuator.com](http://www.intelligentactuator.com)

Technical References Appendix P.15



(\*) Connect the motor-encoder integrated cable here. (See page A-59 for details on cables.)

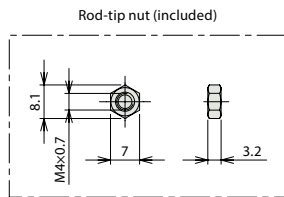
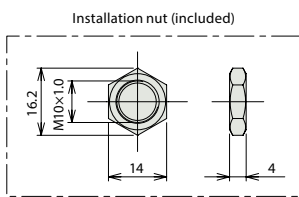
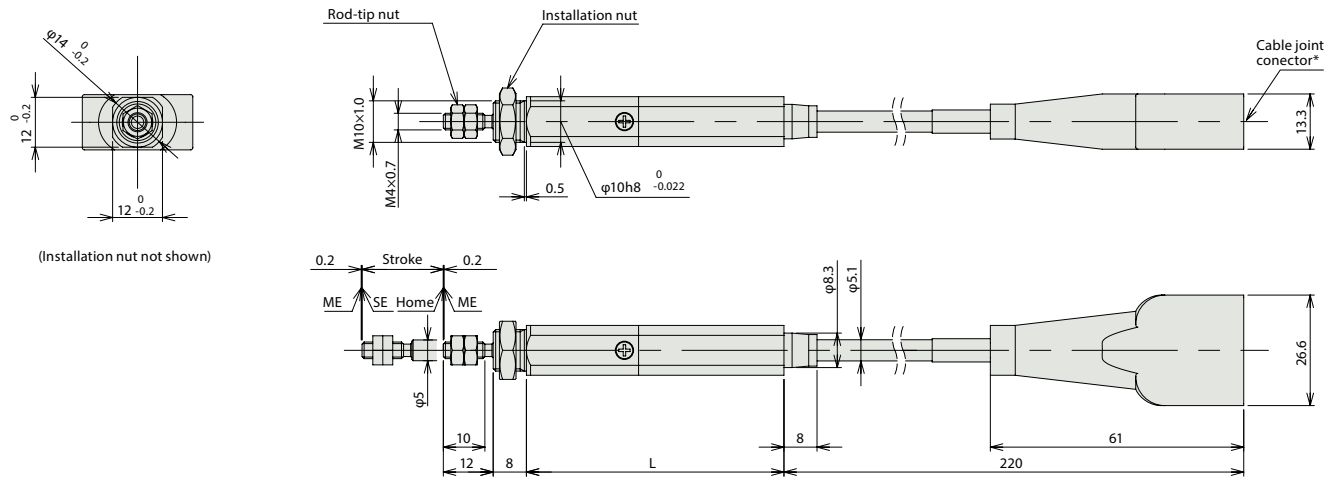

ME: Mechanical end  
SE: Stroke end

Stroke	10	20	30
L	52	62	72
Weight (g)	47	51	55

Applicable Controllers

RCD series actuators can be operated with the controllers indicated below. Select the type according to your intended application.

Name	External view	Model	Description	Maximum number of positioning points	Input Voltage	Power-supply capacity	Standard price	See Page
Solenoid valve type		DSEP-C-3I-①-2-0	Operable with the same signal as a solenoid valve. Supports both single and double solenoid types.	3 points	DC24V	(Standard specification) Rated: 0.7A Maximum: 2.5A	—	→ P547
Dust-proof solenoid valve type		DSEP-CW-3I-①-2-0						

\* ① indicates I/O type (NP/PN).

# RCA2-RA2AC

Robo Cylinder, Mini Rod Type, Motor Unit Coupled Type, Actuator Width 18mm, 24V Servo Motor, Ball Screw Specification

Model Specification Items	<b>RCA2</b>	<b>—RA2AC—</b>	<b>I</b>	<b>— 5 —</b>	<input type="checkbox"/>	<input type="checkbox"/>	<b>A3</b>	<input type="checkbox"/>	<input type="checkbox"/>
	Series	Type	Encoder type	Motor type	Lead	Stroke	Applicable controller	Cable length	Options
			I: Incremental * The Simple absolute encoder is also considered type "I".	5: 5W Servo motor	4 : 4mm 2 : 2mm 1 : 1mm	25: 25mm 100: 100mm (every 25mm)	A3:ASEP MSEP	N: None P: 1m S: 3m M: 5m X <input type="checkbox"/> : Custom Length	See Options below.

\* See page Pre-47 for details on the model descriptions.

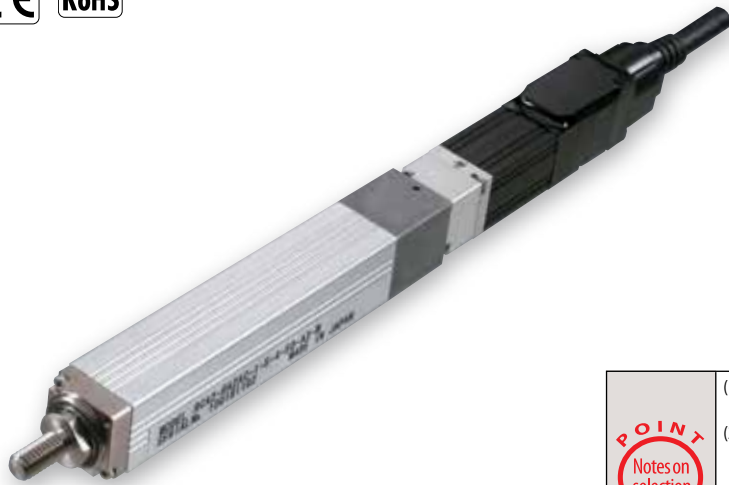

Technical References Appendix P.5

- POINT**  
Notes on selection
- (1) The load capacity is based on operation at an acceleration of 0.3G. This value is the upper limit for the acceleration.
  - (2) The horizontal payload is the value when used in combination with an external guide. Please note that if an external force is applied to the rod in a direction other than the proper direction the rod travels, the detent may get damaged.
  - (3) Take note that, since there is no brake, the slider may come down when the power is turned off if the actuator is used vertically.
  - (4) See page A-71 for details on push motion.

### Actuator Specifications

#### Leads and Payloads

Model number	Motor output (W)	Feed screw	Lead (mm)	Max. Load Capacity		Rated thrust (N)	Positioning Repeatability (mm)	Stroke (mm)
				Horizontal (kg)	Vertical (kg)			
RCA2-RA2AC-I-5-4- <input type="checkbox"/> -A3- <input type="checkbox"/> - <input type="checkbox"/>	5	Ball screw	4	0.5	0.25	21.4	±0.02	25~100 (every 25mm)
RCA2-RA2AC-I-5-2- <input type="checkbox"/> -A3- <input type="checkbox"/> - <input type="checkbox"/>			2	1	0.5	42.3		
RCA2-RA2AC-I-5-1- <input type="checkbox"/> -A3- <input type="checkbox"/> - <input type="checkbox"/>			1	2	1	85.5		

#### Stroke and Maximum Speed

Lead	Stroke	25 (mm)	50~100 (mm)
		Ball screw	4
	2	100	
	1	50	

Code explanation  Stroke  Cable length  Options \*See page A-71 for details on push motion. (Unit: mm/s)

#### ① Stroke

① Stroke (mm)	Standard price
25	—
50	—
75	—
100	—

#### ② Cable Length

Type	Cable symbol	Standard price
Standard (Robot Cables)	P (1m)	—
	S (3m)	—
	M (5m)	—
Special length	X06 (6m) ~ X10 (10m)	—
	X11 (11m) ~ X15 (15m)	—
	X16 (16m) ~ X20 (20m)	—
		—

\* The standard cable for the RCA2 is the robot cable.  
\* See page A-59 for cables for maintenance.

#### ③ Options

Name	Option code	See page	Standard price
Non-motor end specification	NM	→ A-52	—

#### Actuator Specifications

Item	Description
Drive System	Ball screw, ø4mm, rolled C10
Lost motion	0.1mm or less
Base	Material: Aluminum, white alumite treated
Rod non-rotation preciseness	±3.0 deg
Ambient operating temperature, humidity	0 to 40°C, 85% RH or less (Non-condensing)
Service life	5,000km

Dimensional Drawings

CAD drawings can be downloaded from the website.

[www.intelligentactuator.com](http://www.intelligentactuator.com)

For Special Orders

Appendix P.15



- (\*1) Connect the motor-encoder integrated cable here.
- (\*2) During home return, be careful to avoid interference from peripheral objects because the slider travels until the mechanical end.
- (\*3) The orientation of the nut varies depending on the product.

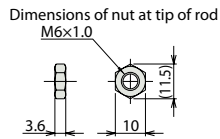
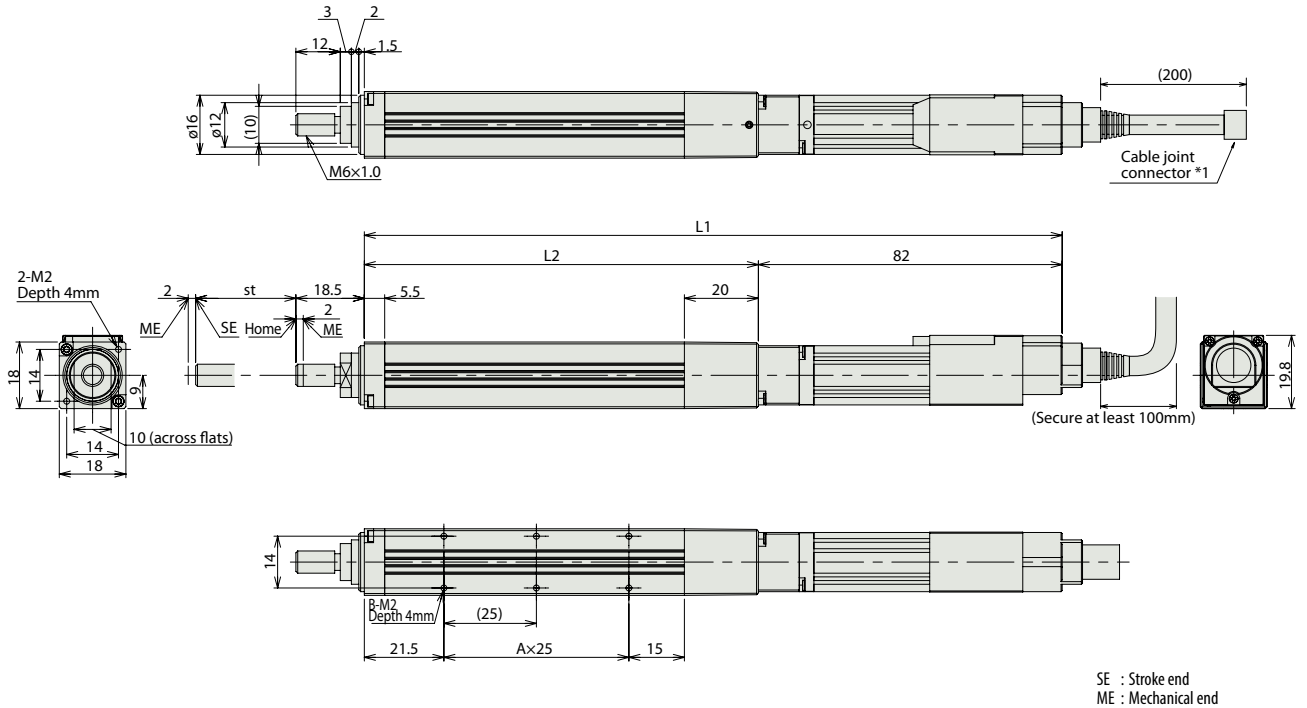

Note:  
Do not apply any external force on the rod from any direction other than the direction of the rod's motion. If a force is exerted on the rod in a perpendicular or rotational direction, the detent may become damaged.

**■ Dimensions and Weight by Stroke**

Stroke	25	50	75	100
L1	163.5	188.5	213.5	238.5
L2	81.5	106.5	131.5	156.5
A	1	2	3	4
B	4	6	8	10
Weight (kg)	0.17	0.19	0.2	0.22

Applicable Controllers

RCA2 series actuators can be operated with the controllers indicated below. Select the type according to your intended application.

Name	External view	Model number	Features	Maximum number of positioning points	Input power	Power supply capacity	Standard price	Reference page
Solenoid valve type		ASEP-C-5SI-①-2-0	Simple controller operable with the same signal as a solenoid valve	3 points	DC24V	1A rated 2A max.	—	→ P547
Solenoid valve multi-axis type PIO specification		MSEP-C-②-③-④-2-0	Positioner type based on PIO control, allowing up to 8 axes to be connected					→ P563
Solenoid valve multi-axis type Network specification		MSEP-C-②-③-④-0-0	Field network-ready positioner type, allowing up to 8 axes to be connected	256 points				—

\* ① indicates I/O type (NP/PN). \* ② indicates number of axes (1 to 8). \* ③ indicates field network specification symbol.

- Slider Type
- Mini
- Standard
- Controller Integrated
- Rod Type
- Mini
- Standard
- Controllers Integrated
- Table/Arm/Flat Type
- Mini
- Standard
- Gripper/Rotary Type
- Linear Servo Type
- Clean-room Type
- Splash-Proof Type
- Pulse Motor
- Servo Motor (24V)
- Servo Motor (200V)
- Linear Servo Motor

- Slider Type
- Mini
- Standard
- Controllers Integrated
- Rod Type
- Mini
- Standard
- Controllers Integrated
- Table/ Arm/ Flat Type
- Mini
- Standard
- Gripper/ Rotary Type
- Linear Servo Type
- Clean-room Type
- Splash-Proof Type
- Pulse Motor
- Servo Motor (24V)
- Servo Motor (200V)
- Linear Servo Motor

# RCA2-RA2AR

Robo Cylinder, Mini Rod Type, Side-mounted Motor Type, Actuator Width 18mm, 24V Servo Motor, Ball Screw Specification

<b>Model Specification Items</b>	<b>RCA2-RA2AR</b>	<b>I</b>	<b>5</b>			<b>A3</b>		
Series	Type	Encoder type	Motor type	Lead	Stroke	Applicable controller	Cable length	Options
		I: Incremental *The Simple absolute encoder is also considered type "I".	S: Servo motor 5W	4 : 4mm 2 : 2mm 1 : 1mm	25: 25mm ↕ 100: 100mm (every 25mm)	A3:ASEP MSEP	N: None P: 1m S: 3m M: 5m X□: Custom Length	See Options below. *Be sure to specify which side the motor is to be mounted (ML/MR).

\* See page Pre-47 for details on the model descriptions.



Pictured: Left-mounted motor model (ML).

**Technical References** [Appendix P.5](#)

- POINT

Notes on selection

  - (1) The load capacity is based on operation at an acceleration of 0.3G. This value is the upper limit for the acceleration.
  - (2) The horizontal payload is the value when used in combination with an external guide. Please note that if an external force is applied to the rod in a direction other than the proper direction the rod travels, the detent may get damaged.
  - (3) Take note that, since there is no brake, the slider may come down when the power is turned off if the actuator is used vertically.
  - (4) See page A-71 for details on push motion.

Actuator Specifications								
Leads and Payloads								
Model number	Motor output (W)	Feed screw	Lead (mm)	Max. Load Capacity		Rated thrust (N)	Positioning Repeatability (mm)	Stroke (mm)
				Horizontal (kg)	Vertical (kg)			
RCA2-RA2AR-I-5-4-①-A3-②-③	5	Ball screw	4	0.5	0.25	21.4	±0.02	25~100 (every 25mm)
RCA2-RA2AR-I-5-2-①-A3-②-③			2	1	0.5	42.3		
RCA2-RA2AR-I-5-1-①-A3-②-③			1	2	1	85.5		

Stroke and Maximum Speed			
Lead	Stroke	25 (mm)	50~100 (mm)
		Ball screw	4
	2	100	
	1	50	

(Unit: mm/s)

Code explanation ① Stroke ② Cable length ③ Options \*See page A-71 for details on push motion.

① Stroke	
① Stroke (mm)	Standard price
25	—
50	—
75	—
100	—

② Cable Length		
Type	Cable symbol	Standard price
Standard (Robot Cables)	P (1m)	—
	S (3m)	—
	M (5m)	—
Special length	X06 (6m) ~ X10 (10m)	—
	X11 (11m) ~ X15 (15m)	—
	X16 (16m) ~ X20 (20m)	—
		—

\* The standard cable for the RCA2 is the robot cable.  
\* See page A-59 for cables for maintenance.

③ Options			
Name	Option code	See page	Standard price
Side-mounted motor to the left	ML	→ A-52	—
Side-mounted motor to the right	MR	→ A-52	—
Side-mounted motor to the top	MT	→ A-52	—
Non-motor end specification	NM	→ A-52	—

Actuator Specifications	
Item	Description
Drive System	Ball screw, ø4mm, rolled C10
Lost Motion	0.1mm or less
Base	Material: Aluminum, white alumite treated
Rod non-rotation preciseness	±3.0 deg
Ambient operating temperature, humidity	0 to 40°C, 85% RH or less (Non-condensing)
Service life	5,000km

Dimensional Drawings

CAD drawings can be downloaded from the website.

[www.intelligentactuator.com](http://www.intelligentactuator.com)

For Special Orders

Appendix P.15



- (\*1) Connect the motor-encoder integrated cable here.
- (\*2) During home return, be careful to avoid interference from peripheral objects because the slider travels until the mechanical end.
- (\*3) The orientation of the nut varies depending on the product.  
\*The drawing below shows the specification with motor side-mounted to the left (ML).

Note:  
Do not apply any external force on the rod from any direction other than the direction of the rod's motion. If a force is exerted on the rod in a perpendicular or rotational direction, the detent may become damaged.

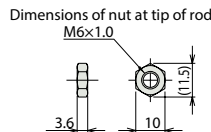
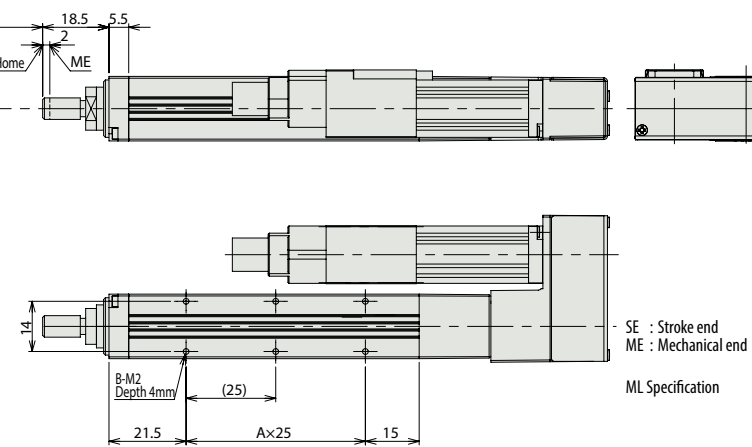
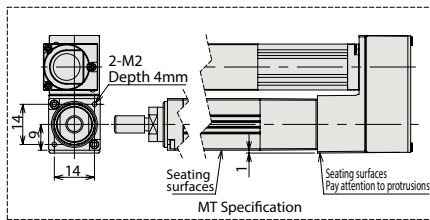
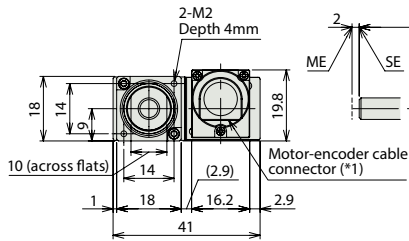
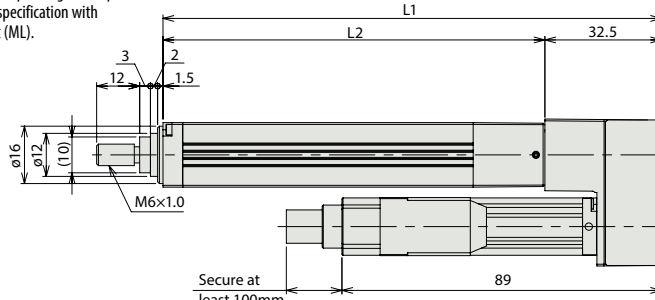

**Dimensions and Weight by Stroke**

Stroke	25	50	75	100
L1	114	139	164	189
L2	81.5	106.5	131.5	156.5
A	1	2	3	4
B	4	6	8	10
Weight (kg)	0.21	0.22	0.24	0.25

Applicable Controllers

RCA2 series actuators can be operated with the controllers indicated below. Select the type according to your intended application.

Name	External view	Model number	Features	Maximum number of positioning points	Input power	Power supply capacity	Standard price	Reference page
Solenoid valve type		ASEP-C-5SI-①-2-0	Simple controller operable with the same signal as a solenoid valve	3 points	DC24V	1A rated 2A max.	—	→ P547
Solenoid valve multi-axis type PIO specification		MSEP-C-①-①-①-2-0	Positioner type based on PIO control, allowing up to 8 axes to be connected					→ P563
Solenoid valve multi-axis type Network specification		MSEP-C-①-①-①-0-0	Field network-ready positioner type, allowing up to 8 axes to be connected	256 points			—	→ P563

\*① indicates I/O type (NP/PN). \*① indicates number of axes (1 to 8). \*①① indicates field network specification symbol.



# RCA2-RN3NA

Robo Cylinder, Mini Rod Type, Short-Length Nut Mounting Type, Actuator  
Width 28mm, 24V Servo Motor, Ball Screw Specification/Lead Screw Specification

Model Specification Items	<b>RCA2</b> — <b>RN3NA</b> — <b>I</b> — <b>10</b> — <input type="checkbox"/> — <input type="checkbox"/> — <input type="checkbox"/> — <input type="checkbox"/> — <input type="checkbox"/>	Series	Type	Encoder type	Motor type	Lead	Stroke	Applicable controller	Cable length	Options
	I: Incremental * The Simple absolute encoder is also considered type "I".	10: 10W Servo motor	4: Ball screw 4mm 2: Ball screw 2mm 1: Ball screw 1mm 4S: Lead screw 4mm 2S: Lead screw 2mm 1S: Lead screw 1mm	30: 30mm 50: 50mm	A1: ACON ASEL A3: AMEC ASEP MSEP	N: None P: 1m S: 3m M: 5m X□□: Custom Length	See options below.			

\* See page Pre-47 for details on the model descriptions.



Power-saving



Technical References Appendix P.5



- The screw is not equipped with an anti-rotation device, so please attach a guide or similar locking device to the tip of the screw prior to use. (If there is no anti-rotation device attached, the screw cannot extend or retract.) When connecting the anti-rotation device to the rod, do not use a floating joint. Please refer to page A-11 for the instruction details.
- The horizontal payload is the value when the actuator uses an external guide.
- The payload is the value when the actuator is operated at an acceleration of 0.3 G (0.2G for lead 1, if used vertically and for lead screw specification). The acceleration limit is the value indicated above.
- Do not apply an external force on the rod in any direction other than the direction the rod is moving in.
- If the actuator is used vertically, pay attention to rod contact because the rod will come down when the power is turned off.
- See page A-71 for details on push motion.

### Actuator Specifications

#### Leads and Payloads

Model number	Motor output (W)	Feed screw	Lead (mm)	Max. Load Capacity		Rated thrust (N)	Positioning Repeatability (mm)	Stroke (mm)
				Horizontal (kg)	Vertical (kg)			
RCA2-RN3NA-I-10-4-①-②-③-④	10	Ball screw	4	0.75	0.25	42.7	±0.02	30 50
RCA2-RN3NA-I-10-2-①-②-③-④			2	1.5	0.5	85.5		
RCA2-RN3NA-I-10-1-①-②-③-④			1	3	1	170.9		
RCA2-RN3NA-I-10-4S-①-②-③-④	10	Lead screw	4	0.25	0.125	25.1	±0.05	30 50
RCA2-RN3NA-I-10-2S-①-②-③-④			2	0.5	0.25	50.3		
RCA2-RN3NA-I-10-1S-①-②-③-④			1	1	0.5	100.5		

#### Stroke and Maximum Speed

Lead	Stroke	Maximum Speed	
		30 (mm)	50 (mm)
Ball screw	4	200	
	2	100	
	1	50	
Lead screw	4	200	
	2	100	
	1	50	

Code explanation ① Stroke ② Applicable controller ③ Cable length ④ Options \*See page A-71 for details on push motion. (Unit: mm/s)

#### ① Stroke

Stroke (mm)	Standard price	
	Ball screw	Lead screw
30	—	—
50	—	—

#### ③ Cable Length

Type	Cable symbol	Standard price
Standard (Robot Cables)	P (1m)	—
	S (3m)	—
	M (5m)	—
Special length	X06 (6m) ~ X10 (10m)	—
	X11 (11m) ~ X15 (15m)	—
	X16 (16m) ~ X20 (20m)	—

\* The standard cable for the RCA2 is the robot cable.  
\* See page A-59 for cables for maintenance.

#### ④ Options

Name	Option code	See page	Standard price
Brake	B	→ A-42	—
Connector cable exits from the left	K1	→ A-51	—
Connector cable exits from the front	K2	→ A-51	—
Connector cable exits from the right	K3	→ A-51	—
Power-saving specification	LA	→ A-52	—

#### Actuator Specifications

Item	Description
Drive System	Ball screw/Lead screw, ø4mm, rolled C10
Lost Motion	Ball screw: 0.1mm or less Lead screw: 0.3mm or less (initial value)
Frame	Material: Aluminum, white alumite treated
Ambient operating temperature, humidity	0 to 40°C, 85% RH or less (Non-condensing)
Service life	Lead screw specification
	Ball screw specification

Dimensional Drawings

CAD drawings can be downloaded from the website.

www.intelligentactuator.com

For Special Orders

Appendix P.15



- (\*1) Connect the motor-encoder integrated cable here.
- (\*2) During home return, be careful to avoid interference from peripheral objects because the slider travels until the mechanical end.
- (\*3) The orientation of the nut varies depending on the product.

Note:  
This product doesn't come with an anti-rotation device. Please add an anti-rotation device such as a guide or similar locking device to the tip of the screw prior to use.

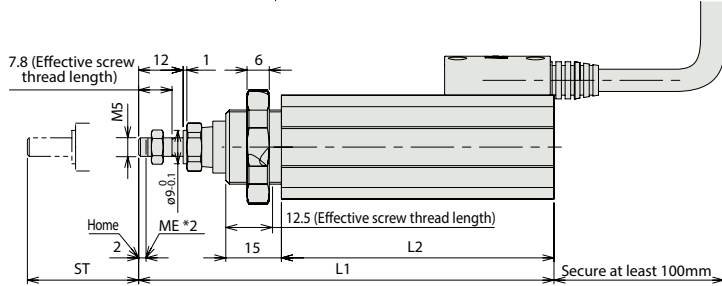
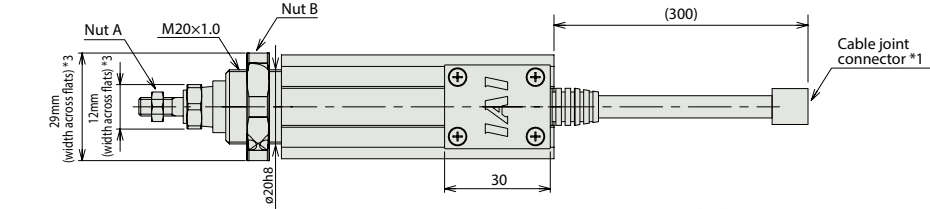
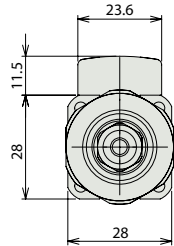

ST : Stroke  
ME : Mechanical end

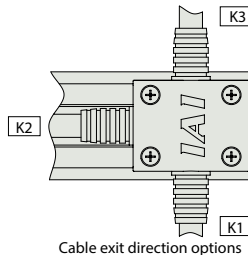
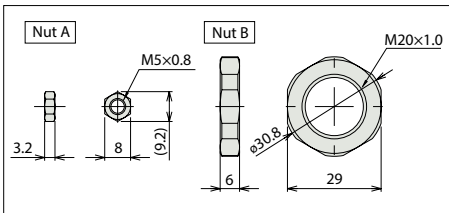
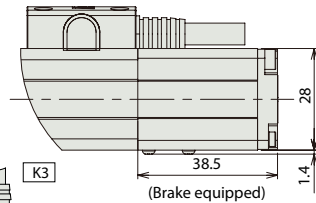
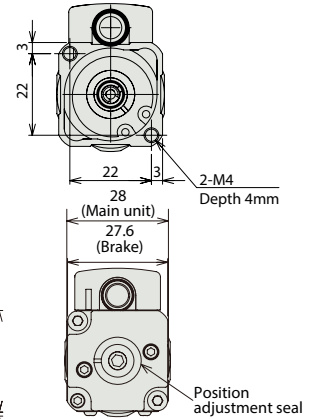

Cable exit direction options

\* Brake-equipped models are heavier by 0.1kg.

Dimensions and Weight by Stroke

Stroke	30	50
L1	112	132
L2	73.5	93.5
Weight (kg)	0.25	0.27

Applicable Controllers

RCA2 series actuators can be operated with the controllers indicated below. Select the type according to your intended application. \* ACON-CY also can be used.

Name	External view	Model number	Features	Maximum number of positioning points	Input power	Power-supply capacity	Standard price	Reference page
Solenoid Valve Type		AMEC-C-10I-①-②-2-1	Easy-to-use controller, even for beginners	3 points	AC100V	2.4A rated	—	→ P537
		ASEP-C-10I-①-②-2-0	Simple controller operable with the same signal as a solenoid valve					→ P547
Solenoid valve multi-axis type PIO specification		MSEP-C-③-④-⑤-2-0	Positioner type based on PIO control, allowing up to 8 axes to be connected	256 points	DC24V	(Standard) 1.3A rated 4.4A max. (Power-saving) 1.3A rated 2.5A max.	—	→ P563
Solenoid valve multi-axis type Network specification		MSEP-C-③-④-⑤-0-0	Field network-ready positioner type, allowing up to 8 axes to be connected					
Positioner type		ACON-C-10I-①-②-2-0	Positioning is possible for up to 512 points	512 points	DC24V	(Standard) 1.3A rated 4.4A max. (Power-saving) 1.3A rated 2.5A max.	—	—
Safety-Compliant Positioner Type		ACON-CG-10I-①-②-2-0						
Pulse Train Input Type (Differential Line Driver)		ACON-PL-10I-①-②-2-0	Pulse train input type with differential line driver support	(—)	DC24V	(Standard) 1.3A rated 4.4A max. (Power-saving) 1.3A rated 2.5A max.	—	→ P631
Pulse Train Input Type (Open Collector)		ACON-PO-10I-①-②-2-0	Pulse train input type with open collector support					
Serial Communication Type		ACON-SE-10I-①-N-0-0	Dedicated Serial Communication	64 points	DC24V	(Standard) 1.3A rated 4.4A max. (Power-saving) 1.3A rated 2.5A max.	—	—
Program Control Type		ASEL-CS-1-10I-①-②-2-0	Programmed operation is possible. Can operate up to 2 axes	1,500 points	DC24V	(Standard) 1.3A rated 4.4A max. (Power-saving) 1.3A rated 2.5A max.	—	→ P675

\* This is for the single-axis ASEL. \* Enter the code "LA" in ① when the power-saving specification is specified. \* ① indicates I/O type (NP/PN). \* ③ indicates number of axes (1 to 8). \* ④ indicates field network specification symbol.



RCA2-RN3NA



Toll Free Phone (877) SERV098  
Toll Free Fax (877) SERV099  
www.electromate.com  
sales@electromate.com

Slider Type

Mini

Standard

Controller Integrated

Rod Type

Mini

Standard

Controllers Integrated

Table/Arm/Flat Type

Mini

Standard

Gripper/Rotary Type

Linear Servo Type

Clean-room Type

Splash-Proof Type

Pulse Motor

Servo Motor (24V)

Servo Motor (200V)

Linear Servo Motor

# RCA2-RN4NA

Robo Cylinder, Mini Rod Type, Short-Length Nut Mounting Type, Actuator Width 34mm, 24V Servo Motor, Ball Screw Specification/Lead Screw Specification

Model Specification Items	<b>RCA2</b> — <b>RN4NA</b> — <b>I</b> — <b>20</b> — <input type="checkbox"/> — <input type="checkbox"/> — <input type="checkbox"/> — <input type="checkbox"/> — <input type="checkbox"/>	Series	Type	Encoder type	Motor type	Lead	Stroke	Applicable controller	Cable length	Options
	I: Incremental * The Simple absolute encoder is also considered type "I".	20: 20W Servo motor	6: Ball screw 6mm 4: Ball screw 4mm 2: Ball screw 2mm 6S: Lead screw 6mm 4S: Lead screw 4mm 2S: Lead screw 2mm	30: 30mm 50: 50mm	A1: ACON ASEL A3: AMEC ASEP MSEP	N: None P: 1m S: 3m M: 5m X□□: Custom Length	See options below.			

\* See page Pre-47 for details on the model descriptions.



Power-saving



Technical References Appendix P.5



- (1) The screw is not equipped with an anti-rotation device, so please attach a guide or similar locking device to the tip of the screw prior to use. (If there is no anti-rotation device attached, the screw cannot extend or retract.) When connecting the anti-rotation device to the rod, do not use a floating joint. Please refer to page A-11 for the instruction details.
- (2) The horizontal payload is the value when the actuator uses an external guide.
- (3) The payload is the value when the actuator is operated at an acceleration of 0.3 G (0.2G for lead 2, if used vertically and for lead screw specification). The acceleration limit is the value indicated above.
- (4) Do not apply an external force on the rod in any direction other than the direction the rod is moving in.
- (5) If the actuator is used vertically, pay attention to rod contact because the rod will come down when the power is turned off.
- (6) See page A-71 for details on push motion.

### Actuator Specifications

#### Leads and Payloads

Model number	Motor output (W)	Feed screw	Lead (mm)	Max. Load Capacity		Rated thrust (N)	Positioning Repeatability (mm)	Stroke (mm)
				Horizontal (kg)	Vertical (kg)			
RCA2-RN4NA-I-20-6-①-②-③-④	20	Ball screw	6	2	0.5	33.8	±0.02	30 50
RCA2-RN4NA-I-20-4-①-②-③-④			4	3	0.75	50.7		
RCA2-RN4NA-I-20-2-①-②-③-④			2	6	1.5	101.5		
RCA2-RN4NA-I-20-6S-①-②-③-④	20	Lead screw	6	0.25	0.125	19.9	±0.05	30 50
RCA2-RN4NA-I-20-4S-①-②-③-④			4	0.5	0.25	29.8		
RCA2-RN4NA-I-20-2S-①-②-③-④			2	1	0.5	59.7		

#### Stroke and Maximum Speed

Lead	Stroke	30 (mm)		50 (mm)	
		Ball screw	Lead screw	Ball screw	Lead screw
Ball screw	6	270	<220>	300	
	4	200			
	2	100			
Lead screw	6	220	300		
	4	200			
	2	100			

Code explanation ① Stroke ② Applicable controller ③ Cable length ④ Options \* See page A-71 for details on push motion. \* The values enclosed in < > apply to vertical settings. (Unit: mm/s)

#### ① Stroke

Stroke (mm)	Standard price	
	Feed screw	
	Ball screw	Lead screw
30	—	—
50	—	—

#### ③ Cable Length

Type	Cable symbol	Standard price
Standard (Robot Cables)	P (1m)	—
	S (3m)	—
	M (5m)	—
Special length	X06 (6m) ~ X10 (10m)	—
	X11 (11m) ~ X15 (15m)	—
	X16 (16m) ~ X20 (20m)	—
		—

\* The standard cable for the RCA2 is the robot cable.  
\* See page A-59 for cables for maintenance.

#### ④ Options

Name	Option code	See page	Standard price
Brake	B	→ A-42	—
Connector cable exits from the left	K1	→ A-51	—
Connector cable exits from the front	K2	→ A-51	—
Connector cable exits from the right	K3	→ A-51	—
Power-saving specification	LA	→ A-52	—

#### Actuator Specifications

Item	Description
Drive System	Ball screw/Lead screw, ø6mm, rolled C10
Lost Motion	Ball screw: 0.1mm or less
	Lead screw: 0.3mm or less (initial value)
Frame	Material: Aluminum, white alumite treated
Ambient operating temperature, humidity	0 to 40°C, 85% RH or less (Non-condensing)
Service life	Lead screw specification
	Ball screw specification

Dimensional Drawings

CAD drawings can be downloaded from the website.

[www.intelligentactuator.com](http://www.intelligentactuator.com)

For Special Orders

Appendix P.15



- (\*1) Connect the motor-encoder integrated cable here.
- (\*2) During home return, be careful to avoid interference from peripheral objects because the slider travels until the mechanical end.
- (\*3) The orientation of the nut varies depending on the product.

Note:  
This product doesn't come with an anti-rotation device. Please add an anti-rotation device such as a guide or similar locking device to the tip of the screw prior to use.

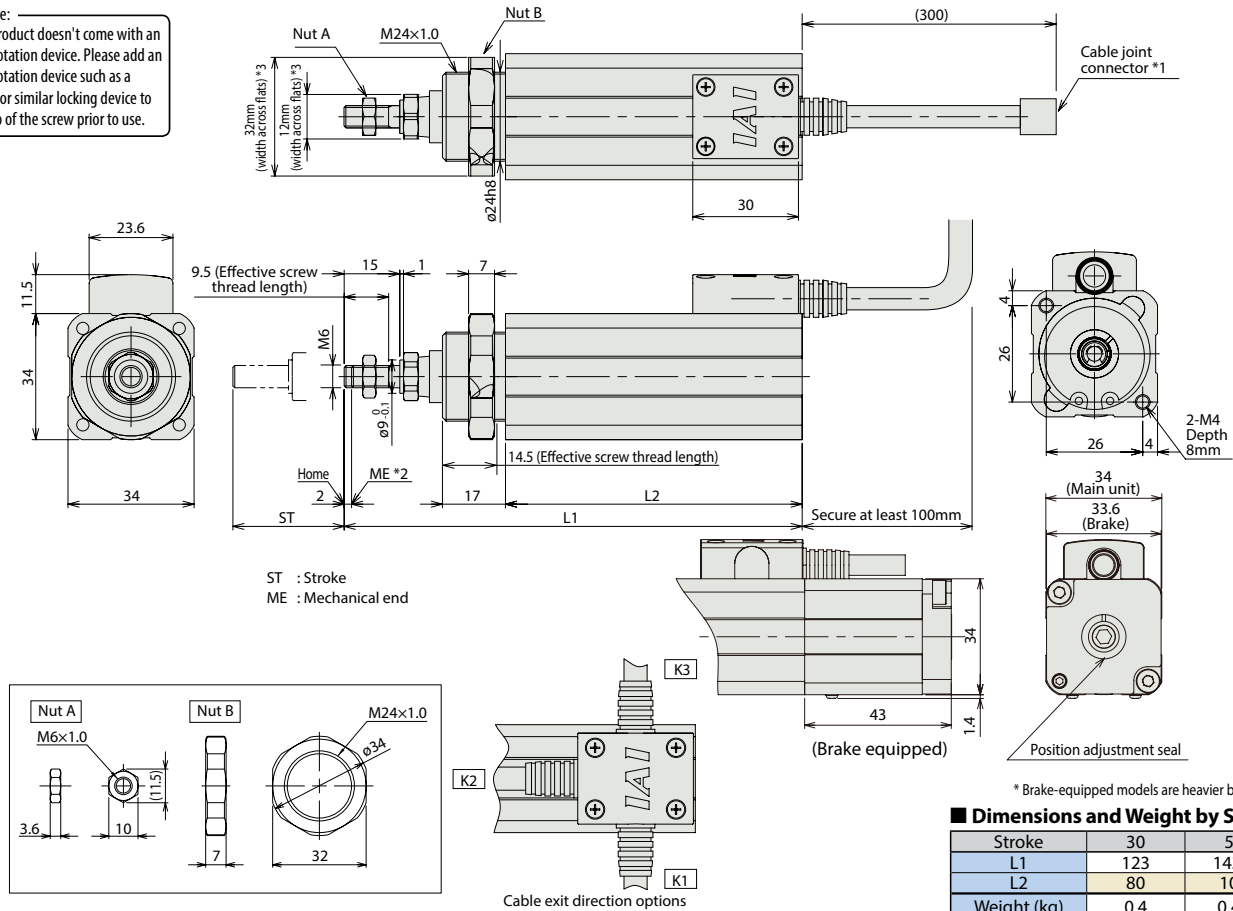

\* Brake-equipped models are heavier by 0.15kg.

**■ Dimensions and Weight by Stroke**

Stroke	30	50
L1	123	143.5
L2	80	100
Weight (kg)	0.4	0.44

Applicable Controllers

RCA2 series actuators can be operated with the controllers indicated below. Select the type according to your intended application. \* ACON-CY also can be used.

Name	External view	Model number	Features	Maximum number of positioning points	Input power	Power-supply capacity	Standard price	Reference page
Solenoid Valve Type		AMEC-C-20I①-②-2-1	Easy-to-use controller, even for beginners	3 points	AC100V	2.4A rated	—	→ P537
		ASEP-C-20I①-②-2-0	Simple controller operable with the same signal as a solenoid valve					→ P547
Solenoid valve multi-axis type PIO specification		MSEP-C-③-④-2-0	Positioner type based on PIO control, allowing up to 8 axes to be connected	256 points	DC24V	(Standard) 1.3A rated 4.4A max. (Power-saving) 1.3A rated 2.5A max.	—	→ P563
Solenoid valve multi-axis type Network specification		MSEP-C-③-④-0-0	Field network-ready positioner type, allowing up to 8 axes to be connected					
Positioner type		ACON-C-20I①-②-2-0	Positioning is possible for up to 512 points	512 points	DC24V	(Standard) 1.3A rated 4.4A max. (Power-saving) 1.3A rated 2.5A max.	—	—
Safety-Compliant Positioner Type		ACON-CG-20I①-②-2-0						
Pulse Train Input Type (Differential Line Driver)		ACON-PL-20I①-②-2-0	Pulse train input type with differential line driver support	(—)	DC24V	(Standard) 1.3A rated 4.4A max. (Power-saving) 1.3A rated 2.5A max.	—	→ P631
Pulse Train Input Type (Open Collector)		ACON-PO-20I①-②-2-0	Pulse train input type with open collector support					
Serial Communication Type		ACON-SE-20I①-N-0-0	Dedicated Serial Communication	64 points	DC24V	(Standard) 1.3A rated 4.4A max. (Power-saving) 1.3A rated 2.5A max.	—	—
Program Control Type		ASEL-CS-1-20I①-②-2-0	Programmed operation is possible. Can operate up to 2 axes	1,500 points	DC24V	(Standard) 1.3A rated 4.4A max. (Power-saving) 1.3A rated 2.5A max.	—	→ P675

\* This is for the single-axis ASEL. \* Enter the code "LA" in ① when the power-saving specification is specified. \* ① indicates I/O type (NP/PN).  
\* ③ indicates number of axes (1 to 8). \* ④ indicates field network specification symbol.



RCA2-RN4NA



Toll Free Phone (877) SERV098  
Toll Free Fax (877) SERV099  
[www.electromate.com](http://www.electromate.com)  
[sales@electromate.com](mailto:sales@electromate.com)

- Slider Type
- Mini
- Standard
- Controllers Integrated
- Rod Type
- Mini
- Standard
- Controllers Integrated
- Table/Arm/Flat Type
- Mini
- Standard
- Gripper/Rotary Type
- Linear Servo Type
- Clean-room Type
- Splash-Proof Type
- Pulse Motor
- Servo Motor (24V)
- Servo Motor (200V)
- Linear Servo Motor

# RCA2-RP3NA

Robo Cylinder, Mini Rod Type, Short-Length Tapped-Hole Mounting Type, Actuator Width 28mm, 24V Servo Motor, Ball Screw Specification/Lead Screw Specification

Model Specification Items	RCA2	RP3NA	I	10					
Series	Type	Encoder type	Motor type	Lead	Stroke	Applicable controller	Cable length	Options	
		I: Incremental * The Simple absolute encoder is also considered type "I".	10: 10W Servo motor	4: Ball screw 4mm 2: Ball screw 2mm 1: Ball screw 1mm 4S: Lead screw 4mm 2S: Lead screw 2mm 1S: Lead screw 1mm	30: 30mm 50: 50mm	A1: ACON ASEL A3: AMEC ASEP MSEP	N: None P: 1m S: 3m M: 5m X□□: Custom Length	See options below.	

\* See page Pre-47 for details on the model descriptions.



Power-saving

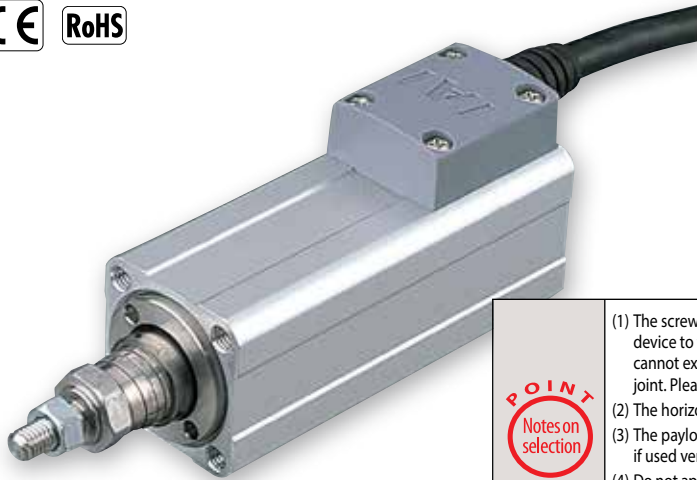

Technical References Appendix P.5



- The screw is not equipped with an anti-rotation device, so please attach a guide or similar locking device to the tip of the screw prior to use. (If there is no anti-rotation device attached, the screw cannot extend or retract.) When connecting the anti-rotation device to the rod, do not use a floating joint. Please refer to page A-11 for the instruction details.
- The horizontal payload is the value when the actuator uses an external guide.
- The payload is the value when the actuator is operated at an acceleration of 0.3 G (0.2G for lead 1, if used vertically and for lead screw specification). The acceleration limit is the value indicated above.
- Do not apply an external force on the rod in any direction other than the direction the rod is moving in.
- If the actuator is used vertically, pay attention to rod contact because the rod will come down when the power is turned off.
- See page A-71 for details on push motion.

### Actuator Specifications

#### Leads and Payloads

Model number	Motor output (W)	Feed screw	Lead (mm)	Max. Load Capacity		Rated thrust (N)	Positioning Repeatability (mm)	Stroke (mm)
				Horizontal (kg)	Vertical (kg)			
RCA2-RP3NA-I-10-4-①-②-③-④	10	Ball screw	4	0.75	0.25	42.7	±0.02	30 50
RCA2-RP3NA-I-10-2-①-②-③-④			2	1.5	0.5	85.5		
RCA2-RP3NA-I-10-1-①-②-③-④			1	3	1	170.9		
RCA2-RP3NA-I-10-4S-①-②-③-④	10	Lead screw	4	0.25	0.125	25.1	±0.05	30 50
RCA2-RP3NA-I-10-2S-①-②-③-④			2	0.5	0.25	50.3		
RCA2-RP3NA-I-10-1S-①-②-③-④			1	1	0.5	100.5		

#### Stroke and Maximum Speed

Lead	Stroke	Maximum Speed	
		30 (mm)	50 (mm)
Ball screw	4	200	
	2	100	
	1	50	
Lead screw	4	200	
	2	100	
	1	50	

Code explanation ① Stroke ② Applicable controller ③ Cable length ④ Options \*See page A-71 for details on push motion. (Unit: mm/s)

#### ① Stroke

Stroke (mm)	Standard price	
	Ball screw	Lead screw
30	—	—
50	—	—

#### ③ Cable Length

Type	Cable symbol	Standard price
Standard (Robot Cables)	P (1m)	—
	S (3m)	—
	M (5m)	—
Special length	X06 (6m) ~ X10 (10m)	—
	X11 (11m) ~ X15 (15m)	—
	X16 (16m) ~ X20 (20m)	—
		—

\* The standard cable for the RCA2 is the robot cable.  
\* See page A-59 for cables for maintenance.

#### ④ Options

Name	Option code	See page	Standard price
Brake	B	→ A-42	—
Connector cable exits from the left	K1	→ A-51	—
Connector cable exits from the front	K2	→ A-51	—
Connector cable exits from the right	K3	→ A-51	—
Power-saving specification	LA	→ A-52	—

#### Actuator Specifications

Item	Description
Drive System	Ball screw/Lead screw, ø4mm, rolled C10
Lost Motion	Ball screw: 0.1mm or less Lead screw: 0.3mm or less (initial value)
Frame	Material: Aluminum, white alumite treated
Ambient operating temperature, humidity	0 to 40°C, 85% RH or less (Non-condensing)
Service life	Lead screw specification
	Ball screw specification

205 RCA2-RP3NA

Dimensional Drawings

CAD drawings can be downloaded from the website.

www.intelligentactuator.com

For Special Orders

Appendix P.15



- (\*1) Connect the motor-encoder integrated cable here.
- (\*2) During home return, be careful to avoid interference from peripheral objects because the slider travels until the mechanical end.
- (\*3) The orientation of the nut varies depending on the product.

Note:  
This product doesn't come with an anti-rotation device. Please add an anti-rotation device such as a guide or similar locking device to the tip of the screw prior to use.

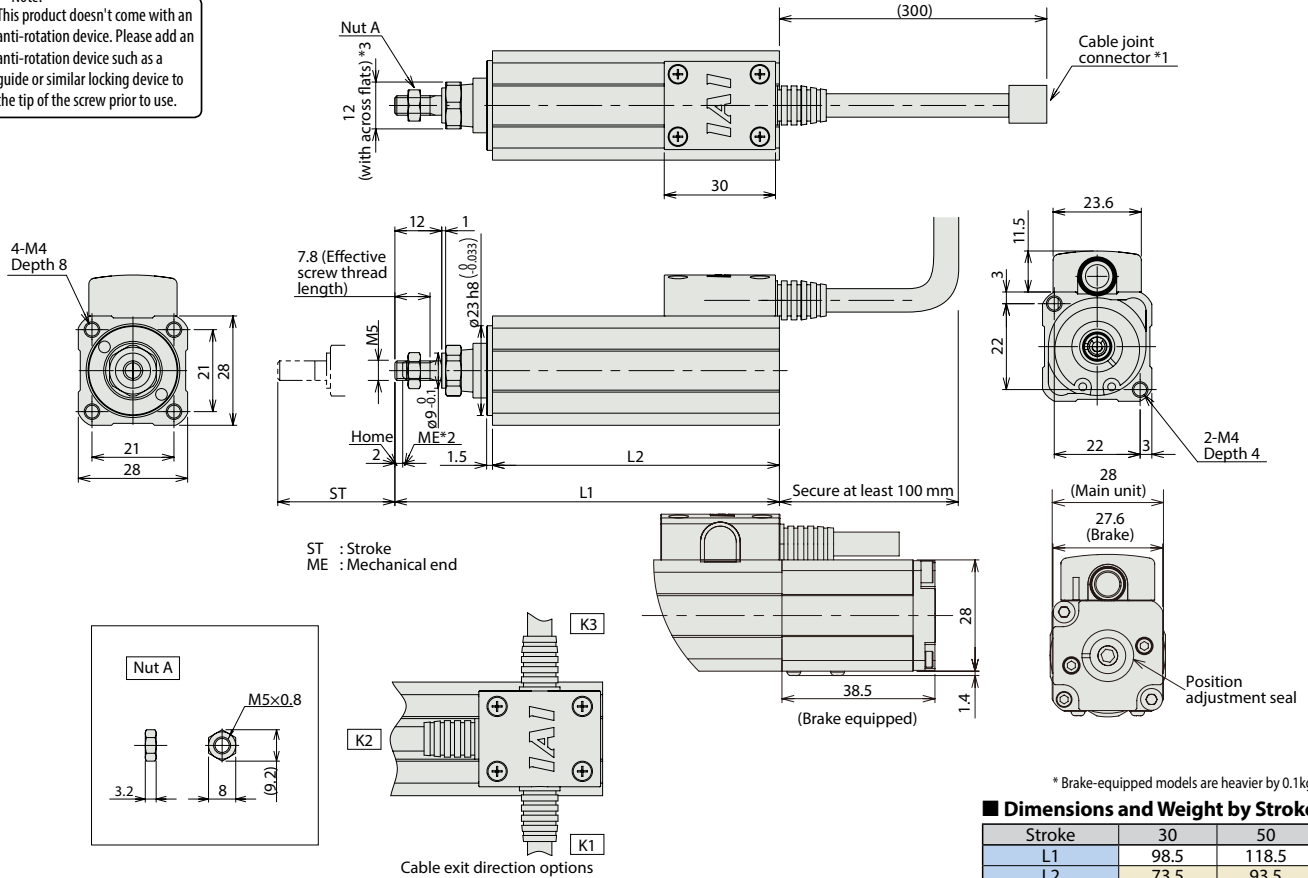

\* Brake-equipped models are heavier by 0.1kg.

Dimensions and Weight by Stroke

Stroke	30	50
L1	98.5	118.5
L2	73.5	93.5
Weight (kg)	0.2	0.22

Applicable Controllers

RCA2 series actuators can be operated with the controllers indicated below. Select the type according to your intended application. \* ACON-CY also can be used.

Name	External view	Model number	Features	Maximum number of positioning points	Input power	Power-supply capacity	Standard price	Reference page											
Solenoid Valve Type		AMEC-C-10I①-②-2-1	Easy-to-use controller, even for beginners	3 points	AC100V	2.4A rated	—	→ P537											
		ASEP-C-10I①-②-2-0	Simple controller operable with the same signal as a solenoid valve					→ P547											
Solenoid valve multi-axis type PIO specification		MSEP-C-③-④-⑤-2-0	Positioner type based on PIO control, allowing up to 8 axes to be connected	256 points				DC24V	(Standard) 1.3A rated 4.4A max.	—	→ P563								
Solenoid valve multi-axis type Network specification		MSEP-C-③-④-⑤-0-0	Field network-ready positioner type, allowing up to 8 axes to be connected																
Positioner type		ACON-C-10I①-②-2-0	Positioning is possible for up to 512 points	512 points							DC24V	(Power-saving) 1.3A rated 2.5A max.	—	→ P631					
Safety-Compliant Positioner Type		ACON-CG-10I①-②-2-0																	
Pulse Train Input Type (Differential Line Driver)		ACON-PL-10I①-②-2-0	Pulse train input type with differential line driver support	(—)											DC24V	(Power-saving) 1.3A rated 2.5A max.	—	→ P631	
Pulse Train Input Type (Open Collector)		ACON-PO-10I①-②-2-0	Pulse train input type with open collector support																
Serial Communication Type		ACON-SE-10I①-N-0-0	Dedicated Serial Communication	64 points	DC24V	(Power-saving) 1.3A rated 2.5A max.	—												→ P675
Program Control Type		ASEL-CS-1-10I①-②-2-0	Programmed operation is possible. Can operate up to 2 axes	1,500 points															

\* This is for the single-axis ASEL. \* Enter the code "LA" in ① when the power-saving specification is specified. \* ① indicates I/O type (NP/PN). \* ③ indicates number of axes (1 to 8). \* ④ indicates field network specification symbol.

# RCA2-RP4NA

Robo Cylinder, Mini Rod Type, Short-Length Tapped-Hole Mounting Type, Actuator Width 34mm, 24V Servo Motor, Ball Screw Specification/Lead Screw Specification

Model Specification Items	<b>RCA2</b> — <b>RP4NA</b> — <b>I</b> — <b>20</b> — <input type="checkbox"/> — <input type="checkbox"/> — <input type="checkbox"/> — <input type="checkbox"/> — <input type="checkbox"/>
Series	— Type — Encoder type — Motor type — Lead — Stroke — Applicable controller — Cable length — Options
	I: Incremental * The Simple absolute encoder is also considered type "I".
	20: 20W Servo motor
	6: Ball screw 6mm 4: Ball screw 4mm 2: Ball screw 2mm 6S: Lead screw 6mm 4S: Lead screw 4mm 2S: Lead screw 2mm
	30: 30mm 50: 50mm
	A1: ACON ASEL A3: AMEC ASEP MSEP
	N: None P: 1m S: 3m M: 5m X□□: Custom Length
	See options below.

\* See page Pre-47 for details on the model descriptions.



Power-saving

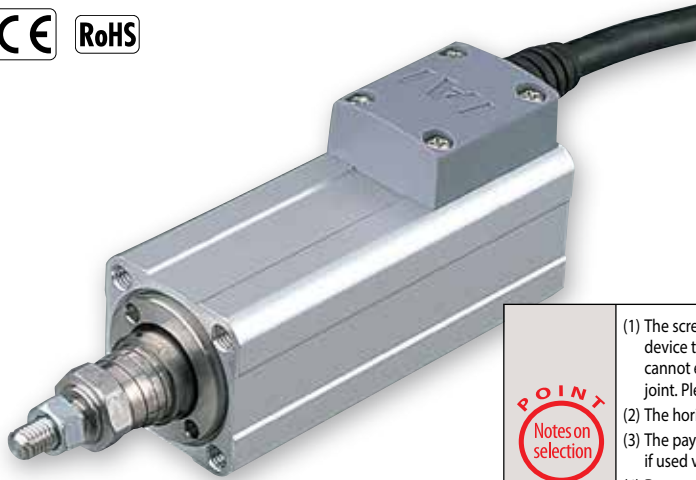

Technical References Appendix P.5



- (1) The screw is not equipped with an anti-rotation device, so please attach a guide or similar locking device to the tip of the screw prior to use. (If there is no anti-rotation device attached, the screw cannot extend or retract.) When connecting the anti-rotation device to the rod, do not use a floating joint. Please refer to page A-11 for the instruction details.
- (2) The horizontal payload is the value when the actuator uses an external guide.
- (3) The payload is the value when the actuator is operated at an acceleration of 0.3 G (0.2G for lead 2, if used vertically and for lead screw specification). The acceleration limit is the value indicated above.
- (4) Do not apply an external force on the rod in any direction other than the direction the rod is moving in.
- (5) If the actuator is used vertically, pay attention to rod contact because the rod will come down when the power is turned off.
- (6) See page A-71 for details on push motion.

### Actuator Specifications

#### Leads and Payloads

Model number	Motor output (W)	Feed screw	Lead (mm)	Max. Load Capacity		Rated thrust (N)	Positioning Repeatability (mm)	Stroke (mm)
				Horizontal (kg)	Vertical (kg)			
RCA2-RP4NA-I-20-6-①-②-③-④	20	Ball screw	6	2	0.5	33.8	±0.02	30 50
RCA2-RP4NA-I-20-4-①-②-③-④			4	3	0.75	50.7		
RCA2-RP4NA-I-20-2-①-②-③-④			2	6	1.5	101.5		
RCA2-RP4NA-I-20-6S-①-②-③-④	20	Lead screw	6	0.25	0.125	19.9	±0.05	30 50
RCA2-RP4NA-I-20-4S-①-②-③-④			4	0.5	0.25	29.8		
RCA2-RP4NA-I-20-2S-①-②-③-④			2	1	0.5	59.7		

#### Stroke and Maximum Speed

Lead	Stroke	30 (mm)	50 (mm)
		Ball screw	6
Lead screw	6	200	
	4	100	
	2	220	300
Lead screw	6	200	
	4	100	
	2	100	

Code explanation ① Stroke ② Applicable controller ③ Cable length ④ Options \*See page A-71 for details on push motion. \*The values enclosed in < > apply to vertical settings. (Unit: mm/s)

#### ① Stroke

Stroke (mm)	Standard price	
	Feed screw	
	Ball screw	Lead screw
30	—	—
50	—	—

#### ③ Cable Length

Type	Cable symbol	Standard price
Standard (Robot Cables)	P (1m)	—
	S (3m)	—
	M (5m)	—
Special length	X06 (6m) ~ X10 (10m)	—
	X11 (11m) ~ X15 (15m)	—
	X16 (16m) ~ X20 (20m)	—
		—

\* The standard cable for the RCA2 is the robot cable.  
\* See page A-59 for cables for maintenance.

#### ④ Options

Name	Option code	See page	Standard price
Brake	B	→ A-42	—
Connector cable exits from the left	K1	→ A-51	—
Connector cable exits from the front	K2	→ A-51	—
Connector cable exits from the right	K3	→ A-51	—
Power-saving specification	LA	→ A-52	—

#### Actuator Specifications

Item	Description
Drive System	Ball screw/Lead screw, ø6mm, rolled C10
Lost Motion	Ball screw: 0.1mm or less
	Lead screw: 0.3mm or less (initial value)
Frame	Material: Aluminum, white alumite treated
Ambient operating temperature, humidity	0 to 40°C, 85% RH or less (Non-condensing)
Service life	Lead screw specification
	Ball screw specification

Dimensional Drawings

CAD drawings can be downloaded from the website.

[www.intelligentactuator.com](http://www.intelligentactuator.com)

For Special Orders Appendix P.15



- (\*1) Connect the motor-encoder integrated cable here.
- (\*2) During home return, be careful to avoid interference from peripheral objects because the slider travels until the mechanical end.
- (\*3) The orientation of the nut varies depending on the product.

Note:  
This product doesn't come with an anti-rotation device. Please add an anti-rotation device such as a guide or similar locking device to the tip of the screw prior to use.

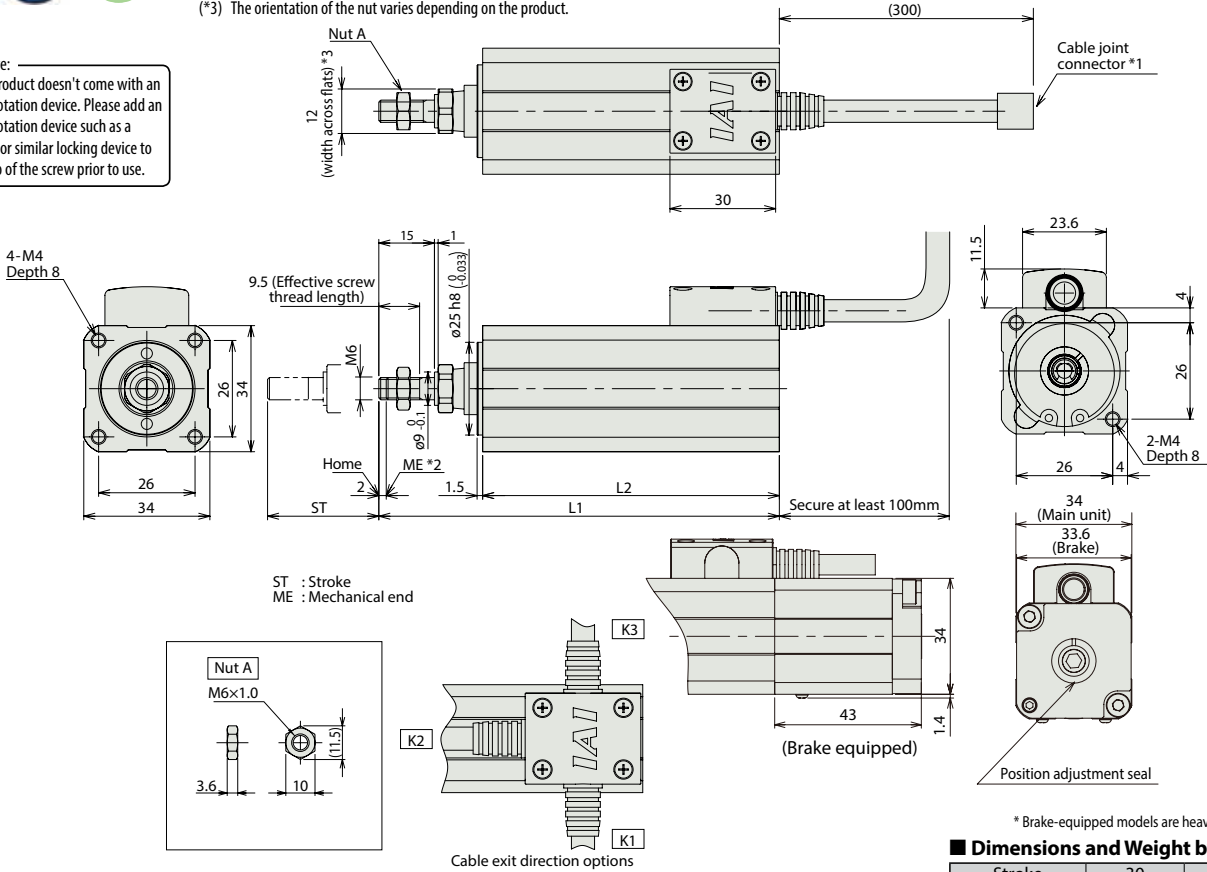

■ Dimensions and Weight by Stroke

Stroke	30	50
L1	108	128
L2	80	100
Weight (kg)	0.32	0.36

② Applicable Controllers

RCA2 series actuators can be operated with the controllers indicated below. Select the type according to your intended application. \* ACON-CY also can be used.

Name	External view	Model number	Features	Maximum number of positioning points	Input power	Power-supply capacity	Standard price	Reference page
Solenoid Valve Type		AMEC-C-20I①①-2-1	Easy-to-use controller, even for beginners	3 points	AC100V	2.4A rated	—	→ P537
		ASEP-C-20I①①-2-0	Simple controller operable with the same signal as a solenoid valve					→ P547
Solenoid valve multi-axis type PIO specification		MSEP-C-①①①①①①①①-2-0	Positioner type based on PIO control, allowing up to 8 axes to be connected	256 points	DC24V	(Standard) 1.3A rated 4.4A max. (Power-saving) 1.3A rated 2.5A max.	—	→ P563
Solenoid valve multi-axis type Network specification		MSEP-C-①①①①①①①①-0-0	Field network-ready positioner type, allowing up to 8 axes to be connected					
Positioner type		ACON-C-20I①①①①-2-0	Positioning is possible for up to 512 points	512 points	DC24V	(Standard) 1.3A rated 4.4A max. (Power-saving) 1.3A rated 2.5A max.	—	—
Safety-Compliant Positioner Type		ACON-CG-20I①①①①-2-0						
Pulse Train Input Type (Differential Line Driver)		ACON-PL-20I①①①①-2-0	Pulse train input type with differential line driver support	(—)	DC24V	(Standard) 1.3A rated 4.4A max. (Power-saving) 1.3A rated 2.5A max.	—	→ P631
Pulse Train Input Type (Open Collector)		ACON-PO-20I①①①①-2-0	Pulse train input type with open collector support					
Serial Communication Type		ACON-SE-20I①①-N-0-0	Dedicated Serial Communication	64 points	DC24V	(Standard) 1.3A rated 4.4A max. (Power-saving) 1.3A rated 2.5A max.	—	—
Program Control Type		ASEL-CS-1-20I①①①①-2-0	Programmed operation is possible. Can operate up to 2 axes	1,500 points	DC24V	(Standard) 1.3A rated 4.4A max. (Power-saving) 1.3A rated 2.5A max.	—	→ P675

\* This is for the single-axis ASEL. \* Enter the code "LA" in ① when the power-saving specification is specified. \* ① indicates I/O type (NP/PN). \* ①① indicates number of axes (1 to 8). \* ①①①① indicates field network specification symbol.



# RCA2-GS3NA

Robo Cylinder, Mini Rod Type, Short-Length Single-Guide Type, Actuator Width 28mm, 24V Servo Motor, Ball Screw Specification/Lead Screw Specification

Model Specification Items	<b>RCA2</b> — <b>GS3NA</b> — <b>I</b> — <b>10</b> — <input type="checkbox"/> — <input type="checkbox"/> — <input type="checkbox"/> — <input type="checkbox"/> — <input type="checkbox"/>	Series	Type	Encoder type	Motor type	Lead	Stroke	Applicable controller	Cable length	Options
	I: Incremental * The Simple absolute encoder is also considered type "I".	10: 10W Servo motor	4: Ball screw 4mm 2: Ball screw 2mm 1: Ball screw 1mm 4S: Lead screw 4mm 2S: Lead screw 2mm 1S: Lead screw 1mm	30: 30mm 50: 50mm	A1: ACON ASEL A3: AMEC ASEP MSEP	N: None P: 1m S: 3m M: 5m X□□: Custom Length	See options below.			

\* See page Pre-47 for details on the model descriptions.



Power-saving

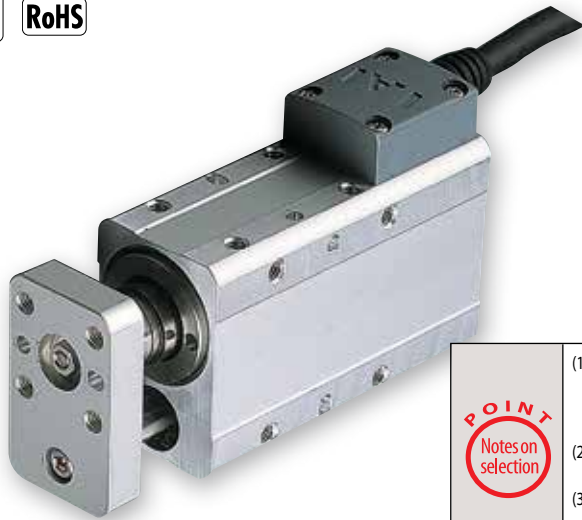

Technical References Appendix P.5



- (1) The horizontal payload is the value when used in combination with a guide so that a radial load and moment load are not applied to the rod. Please refer to page A-110 for correlation diagrams of the end load and service life when a guide is not installed. Also note that single-guide types cannot be used if a force is applied in the rotating direction. Use double-guide types in these applications.
- (2) The payload is the value when the actuator is operated at an acceleration of 0.3 G (0.2G for lead 1, if used vertically and for lead screw specification). The acceleration limit is the value indicated above.
- (3) If the actuator is used vertically, pay attention to rod contact because the rod will come down when the power is turned off.
- (4) See page A-71 for details on push motion.

### Actuator Specifications

#### Leads and Payloads

Model number	Motor output (W)	Feed screw	Lead (mm)	Max. Load Capacity		Rated thrust (N)	Positioning Repeatability (mm)	Stroke (mm)
				Horizontal (kg)	Vertical (kg)			
RCA2-GS3NA-I-10-4-①-②-③-④	10	Ball screw	4	0.75	0.25	42.7	±0.02	30 50
RCA2-GS3NA-I-10-2-①-②-③-④			2	1.5	0.5	85.5		
RCA2-GS3NA-I-10-1-①-②-③-④			1	3	1	170.9		
RCA2-GS3NA-I-10-4S-①-②-③-④	10	Lead screw	4	0.25	0.125	25.1	±0.05	30 50
RCA2-GS3NA-I-10-2S-①-②-③-④			2	0.5	0.25	50.3		
RCA2-GS3NA-I-10-1S-①-②-③-④			1	1	0.5	100.5		

#### Stroke and Maximum Speed

Lead	Stroke	30 (mm)		50 (mm)	
		Lead	Stroke	Lead	Stroke
Ball screw	4	—	200	—	—
	2	—	100	—	—
	1	—	50	—	—
Lead screw	4	—	200	—	—
	2	—	100	—	—
	1	—	50	—	—

Code explanation ① Stroke ② Applicable controller ③ Cable length ④ Options \*See page A-71 for details on push motion. (Unit: mm/s)

#### ① Stroke

Stroke (mm)	Standard price	
	Feed screw	
	Ball screw	Lead screw
30	—	—
50	—	—

#### ③ Cable Length

Type	Cable symbol	Standard price
Standard (Robot Cables)	P (1m)	—
	S (3m)	—
	M (5m)	—
Special length	X06 (6m) ~ X10 (10m)	—
	X11 (11m) ~ X15 (15m)	—
	X16 (16m) ~ X20 (20m)	—
	—	—

\* The standard cable for the RCA2 is the robot cable.  
\* See page A-59 for cables for maintenance.

#### ④ Options

Name	Option code	See page	Standard price
Brake	B	→ A-42	—
Connector cable exits from the left	K1	→ A-51	—
Connector cable exits from the front	K2	→ A-51	—
Connector cable exits from the right	K3	→ A-51	—
Power-saving specification	LA	→ A-52	—

#### Actuator Specifications

Item	Description
Drive System	Ball screw/Lead screw, ø4mm, rolled C10
Lost Motion	Ball screw: 0.1mm or less
	Lead screw: 0.3mm or less (initial value)
Frame	Material: Aluminum, white alumite treated
Ambient operating temperature, humidity	0 to 40°C, 85% RH or less (Non-condensing)
Service life	Lead screw specification
	Ball screw specification

Dimensional Drawings

CAD drawings can be downloaded from the website.

www.intelligentactuator.com

For Special Orders

Appendix P.15



(\*1) Connect the motor-encoder integrated cable here.

(\*2) During home return, be careful to avoid interference from peripheral objects because the slider travels until the mechanical end.

\*Please make sure the screw-in depth doesn't exceed this dimension.

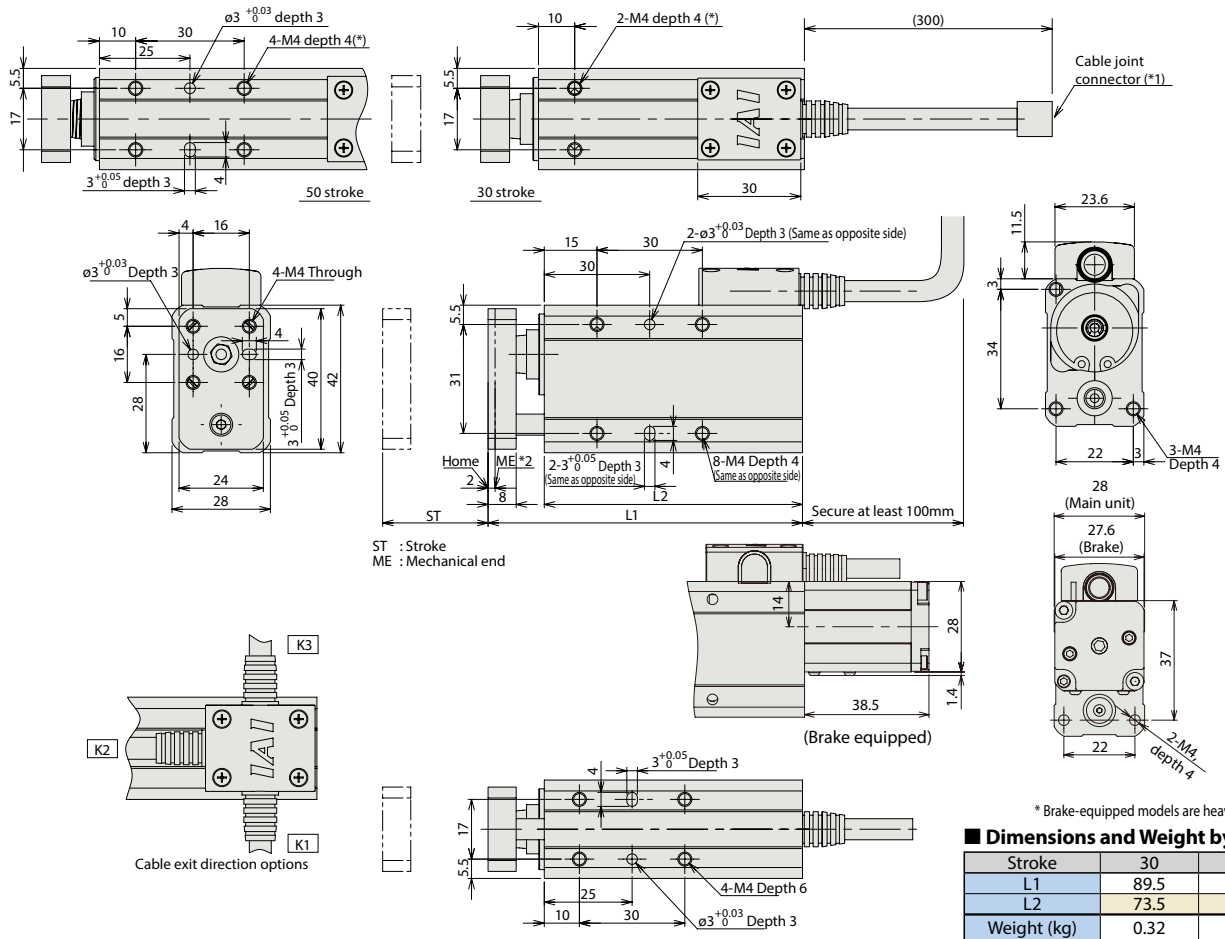

\* Brake-equipped models are heavier by 0.1kg.

**■ Dimensions and Weight by Stroke**

Stroke	30	50
L1	89.5	109.5
L2	73.5	93.5
Weight (kg)	0.32	0.36

Applicable Controllers

RCA2 series actuators can be operated with the controllers indicated below. Select the type according to your intended application. \* ACON-CY also can be used.

Name	External view	Model number	Features	Maximum number of positioning points	Input power	Power-supply capacity	Standard price	Reference page
Solenoid Valve Type		AMEC-C-10I①-②-2-1	Easy-to-use controller, even for beginners	3 points	AC100V	2.4A rated	—	→ P537
		ASEP-C-10I①-②-2-0	Simple controller operable with the same signal as a solenoid valve					→ P547
Solenoid valve multi-axis type PIO specification		MSEP-C-③-④-⑤-2-0	Positioner type based on PIO control, allowing up to 8 axes to be connected	256 points	DC24V	(Standard) 1.3A rated 4.4A max. (Power-saving) 1.3A rated 2.5A max.	—	→ P563
Solenoid valve multi-axis type Network specification		MSEP-C-③-④-⑤-0-0	Field network-ready positioner type, allowing up to 8 axes to be connected					
Positioner type		ACON-C-10I①-②-2-0	Positioning is possible for up to 512 points	512 points	DC24V	(Standard) 1.3A rated 4.4A max. (Power-saving) 1.3A rated 2.5A max.	—	—
Safety-Compliant Positioner Type		ACON-CG-10I①-②-2-0						
Pulse Train Input Type (Differential Line Driver)		ACON-PL-10I①-②-2-0	Pulse train input type with differential line driver support	(—)	DC24V	(Standard) 1.3A rated 4.4A max. (Power-saving) 1.3A rated 2.5A max.	—	→ P631
Pulse Train Input Type (Open Collector)		ACON-PO-10I①-②-2-0	Pulse train input type with open collector support					
Serial Communication Type		ACON-SE-10I①-N-0-0	Dedicated Serial Communication	64 points	DC24V	(Standard) 1.3A rated 4.4A max. (Power-saving) 1.3A rated 2.5A max.	—	—
Program Control Type		ASEL-CS-1-10I①-②-2-0	Programmed operation is possible. Can operate up to 2 axes	1,500 points	DC24V	(Standard) 1.3A rated 4.4A max. (Power-saving) 1.3A rated 2.5A max.	—	→ P675

\* This is for the single-axis ASEL. \* Enter the code "LA" in ① when the power-saving specification is specified. \* ① indicates I/O type (NP/PN). \* ③ indicates number of axes (1 to 8). \* ④ indicates field network specification symbol.



RCA2-GS3NA



Toll Free Phone (877) SERV098  
Toll Free Fax (877) SERV099  
www.electromate.com  
sales@electromate.com

- Slider Type
- Mini
- Standard
- Controller Integrated
- Rod Type
- Mini
- Standard
- Controllers Integrated
- Table/Arm/Flat Type
- Mini
- Standard
- Gripper/Rotary Type
- Linear Servo Type
- Clean-room Type
- Splash-Proof Type
- Pulse Motor
- Servo Motor (24V)
- Servo Motor (200V)
- Linear Servo Motor

# RCA2-GS4NA

Robo Cylinder, Mini Rod Type, Short-Length Single-Guide Type, Actuator Width 34mm, 24V Servo Motor, Ball Screw Specification/Lead Screw Specification

Model Specification Items	<b>RCA2</b> — <b>GS4NA</b> — <b>I</b> — <b>20</b> — <input type="checkbox"/> — <input type="checkbox"/> — <input type="checkbox"/> — <input type="checkbox"/> — <input type="checkbox"/>	Series	Type	Encoder type	Motor type	Lead	Stroke	Applicable controller	Cable length	Options
	I: Incremental * The Simple absolute encoder is also considered type "I".	20: 20W Servo motor	6: Ball screw 6mm 4: Ball screw 4mm 2: Ball screw 2mm 6S: Lead screw 6mm 4S: Lead screw 4mm 2S: Lead screw 2mm	30: 30mm 50: 50mm	A1: ACON ASEL A3: AMEC ASEP MSEP	N: None P: 1m S: 3m M: 5m X□□: Custom Length	See options below.			

\* See page Pre-47 for details on the model descriptions.

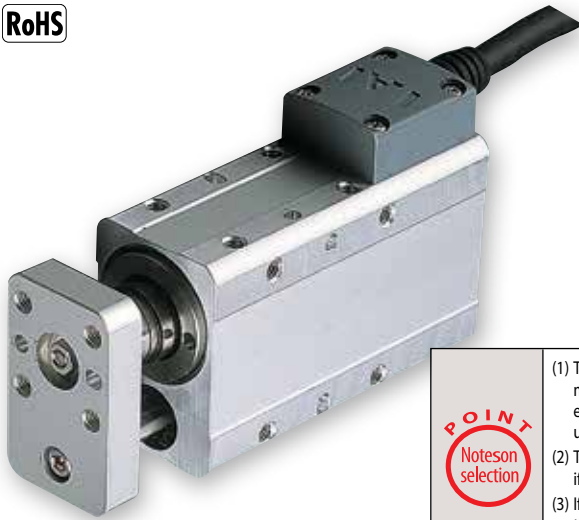

Power-saving

Technical References Appendix P.5



- (1) The horizontal payload is the value when used in combination with a guide so that a radial load and moment load are not applied to the rod. Please refer to page A-110 for correlation diagrams of the end load and service life when a guide is not installed. Also note that single-guide types cannot be used if a force is applied in the rotating direction. Use double-guide types in these applications.
- (2) The payload is the value when the actuator is operated at an acceleration of 0.3 G (0.2G for lead 2, if used vertically and for lead screw specification). The acceleration limit is the value indicated above.
- (3) If the actuator is used vertically, pay attention to rod contact because the rod will come down when the power is turned off.
- (4) See page A-71 for details on push motion.

### Actuator Specifications

#### Leads and Payloads

Model number	Motor output (W)	Feed screw	Lead (mm)	Max. Load Capacity		Rated thrust (N)	Positioning Repeatability (mm)	Stroke (mm)
				Horizontal (kg)	Vertical (kg)			
RCA2-GS4NA-I-20-6-①-②-③-④	20	Ball screw	6	2	0.5	33.8	±0.02	30 50
RCA2-GS4NA-I-20-4-①-②-③-④			4	3	0.75	50.7		
RCA2-GS4NA-I-20-2-①-②-③-④			2	6	1.5	101.5		
RCA2-GS4NA-I-20-6S-①-②-③-④	20	Lead screw	6	0.25	0.125	19.9	±0.05	30 50
RCA2-GS4NA-I-20-4S-①-②-③-④			4	0.5	0.25	29.8		
RCA2-GS4NA-I-20-2S-①-②-③-④			2	1	0.5	59.7		

#### Stroke and Maximum Speed

Lead	Stroke	30 (mm)		50 (mm)	
		30 (mm)	50 (mm)	30 (mm)	50 (mm)
Ball screw	6	270 <220>		300	
	4	200			
	2	100			
Lead screw	6	220	300		
	4	200			
	2	100			

Code explanation ① Stroke ② Applicable controller ③ Cable length ④ Options \*See page A-71 for details on push motion. \*The values enclosed in < > apply to vertical settings. (Unit: mm/s)

#### ① Stroke

Stroke (mm)	Standard price	
	Feed screw	
	Ball screw	Lead screw
30	—	—
50	—	—

#### ③ Cable Length

Type	Cable symbol	Standard price
Standard (Robot Cables)	P (1m)	—
	S (3m)	—
	M (5m)	—
Special length	X06 (6m) ~ X10 (10m)	—
	X11 (11m) ~ X15 (15m)	—
	X16 (16m) ~ X20 (20m)	—
		—

\*The standard cable for the RCA2 is the robot cable. \*See page A-59 for cables for maintenance.

#### ④ Options

Name	Option code	See page	Standard price
Brake	B	→ A-42	—
Connector cable exits from the left	K1	→ A-51	—
Connector cable exits from the front	K2	→ A-51	—
Connector cable exits from the right	K3	→ A-51	—
Power-saving specification	LA	→ A-52	—

#### Actuator Specifications

Item	Description
Drive System	Ball screw/Lead screw, ø6mm, rolled C10
Lost Motion	Ball screw: 0.1mm or less
	Lead screw: 0.3mm or less (initial value)
Frame	Material: Aluminum, white alumite treated
Ambient operating temperature, humidity	0 to 40°C, 85% RH or less (Non-condensing)
Service life	Lead screw specification
	Ball screw specification

211 RCA2-GS4NA

Dimensional Drawings

CAD drawings can be downloaded from the website. [www.intelligentactuator.com](http://www.intelligentactuator.com)

For Special Orders Appendix P.15



(\*1) Connect the motor-encoder integrated cable here.  
 (\*2) During home return, be careful to avoid interference from peripheral objects because the slider travels until the mechanical end.  
 \*Please make sure the screw-in depth doesn't exceed this dimension.

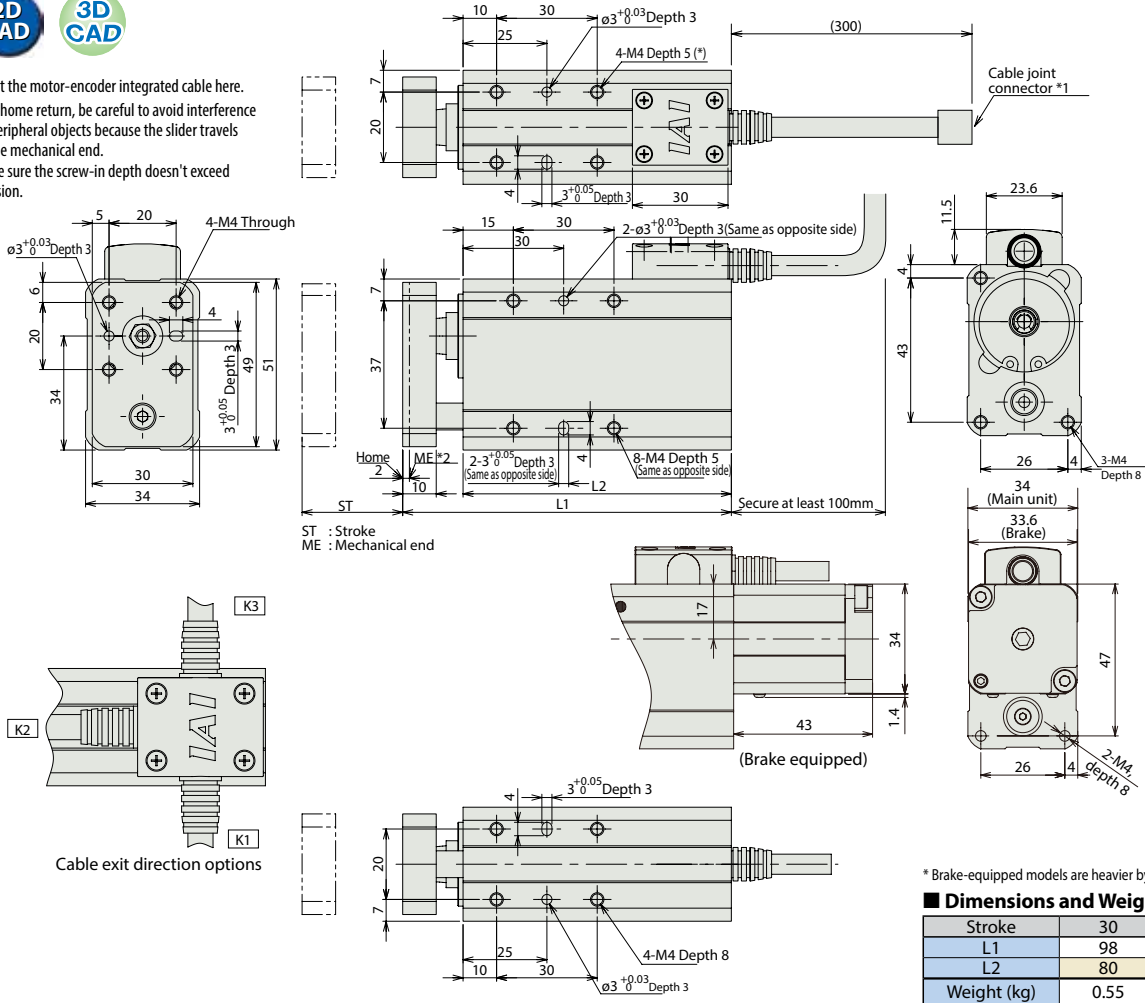

■ Dimensions and Weight by Stroke

Stroke	30	50
L1	98	118
L2	80	100
Weight (kg)	0.55	0.63

② Applicable Controllers

RCA2 series actuators can be operated with the controllers indicated below. Select the type according to your intended application. \* ACON-CY also can be used.

Name	External view	Model number	Features	Maximum number of positioning points	Input power	Power-supply capacity	Standard price	Reference page
Solenoid Valve Type		AMEC-C-20I①-②-2-1	Easy-to-use controller, even for beginners	3 points	AC100V	2.4A rated	—	→ P537
		ASEP-C-20I①-②-2-0	Simple controller operable with the same signal as a solenoid valve					→ P547
Solenoid valve multi-axis type PIO specification		MSEP-C-③④⑤⑥⑦⑧-2-0	Positioner type based on PIO control, allowing up to 8 axes to be connected	256 points	DC24V	(Standard) 1.3A rated 4.4A max.	—	→ P563
Solenoid valve multi-axis type Network specification		MSEP-C-③④⑤⑥⑦⑧-④-0-0	Field network-ready positioner type, allowing up to 8 axes to be connected					
Positioner type		ACON-C-20I①-②-2-0	Positioning is possible for up to 512 points	512 points	DC24V	(Power-saving) 1.3A rated 2.5A max.	—	→ P631
Safety-Compliant Positioner Type		ACON-CG-20I①-②-2-0						
Pulse Train Input Type (Differential Line Driver)		ACON-PL-20I①-②-2-0	Pulse train input type with differential line driver support	(—)	DC24V	(Power-saving) 1.3A rated 2.5A max.	—	→ P631
Pulse Train Input Type (Open Collector)		ACON-PO-20I①-②-2-0	Pulse train input type with open collector support					
Serial Communication Type		ACON-SE-20I①-N-0-0	Dedicated Serial Communication	64 points	DC24V	(Power-saving) 1.3A rated 2.5A max.	—	→ P675
Program Control Type		ASEL-CS-1-20I①-②-2-0	Programmed operation is possible. Can operate up to 2 axes	1,500 points	DC24V	(Power-saving) 1.3A rated 2.5A max.	—	→ P675

\* This is for the single-axis ASEL. \* Enter the code "LA" in ① when the power-saving specification is specified. \* ③④⑤⑥⑦⑧ indicates I/O type (NP/PN).  
 \* ③④⑤⑥⑦⑧ indicates number of axes (1 to 8). \* ④⑤⑥⑦⑧ indicates field network specification symbol.



RCA2-GS4NA



Toll Free Phone (877) SERV098  
 Toll Free Fax (877) SERV099  
[www.electromate.com](http://www.electromate.com)  
[sales@electromate.com](mailto:sales@electromate.com)

- Slider Type
- Mini
- Standard
- Controller Integrated
- Rod Type
- Mini
- Standard
- Controllers Integrated
- Table/ Arm/ Flat Type
- Mini
- Standard
- Gripper/ Rotary Type
- Linear Servo Type
- Clean-room Type
- Splash-Proof Type
- Pulse Motor
- Servo Motor (24V)
- Servo Motor (200V)
- Linear Servo Motor

# RCA2-GD3NA

Robo Cylinder, Mini Rod Type, Short-Length Double-Guide Type, Actuator Width 28mm, 24V Servo Motor, Ball Screw Specification/Lead Screw Specification

Model Specification Items	<b>RCA2</b> — <b>GD3NA</b> — <b>I</b> — <b>10</b> — <input type="checkbox"/> — <input type="checkbox"/> — <input type="checkbox"/> — <input type="checkbox"/> — <input type="checkbox"/>	Series	Type	Encoder type	Motor type	Lead	Stroke	Applicable controller	Cable length	Options
	I: Incremental * The Simple absolute encoder is also considered type "I".	10: 10W Servo motor	4: Ball screw 4mm 2: Ball screw 2mm 1: Ball screw 1mm 4S: Lead screw 4mm 2S: Lead screw 2mm 1S: Lead screw 1mm	30: 30mm 50: 50mm	A1: ACON ASEL A3: AMEC ASEP MSEP	N: None P: 1m S: 3m M: 5m X□□: Custom Length	See options below.			

\* See page Pre-47 for details on the model descriptions.



Power-saving

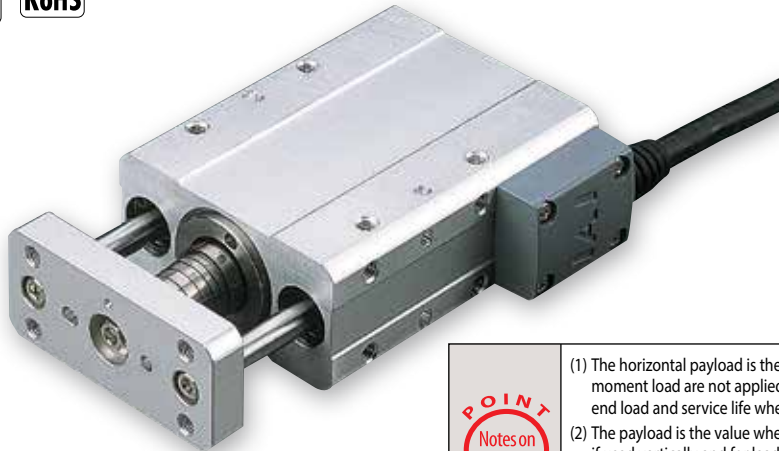

Technical References Appendix P.5



- (1) The horizontal payload is the value when used in combination with a guide so that a radial load and moment load are not applied to the rod. Please refer to page A-111 for correlation diagrams of the end load and service life when a guide is not installed.
- (2) The payload is the value when the actuator is operated at an acceleration of 0.3 G (0.2G for lead 1, if used vertically and for lead screw specification). The acceleration limit is the value indicated above.
- (3) If the actuator is used vertically, pay attention to rod contact because the rod will come down when the power is turned off.
- (4) See page A-71 for details on push motion.

### Actuator Specifications

#### Leads and Payloads

Model number	Motor output (W)	Feed screw	Lead (mm)	Max. Load Capacity		Rated thrust (N)	Positioning Repeatability (mm)	Stroke (mm)
				Horizontal (kg)	Vertical (kg)			
RCA2-GD3NA-I-10-4-①-②-③-④	10	Ball screw	4	0.75	0.25	42.7	±0.02	30 50
RCA2-GD3NA-I-10-2-①-②-③-④			2	1.5	0.5	85.5		
RCA2-GD3NA-I-10-1-①-②-③-④			1	3	1	170.9		
RCA2-GD3NA-I-10-4S-①-②-③-④	10	Lead screw	4	0.25	0.125	25.1	±0.05	30 50
RCA2-GD3NA-I-10-2S-①-②-③-④			2	0.5	0.25	50.3		
RCA2-GD3NA-I-10-1S-①-②-③-④			1	1	0.5	100.5		

#### Stroke and Maximum Speed

Lead	Stroke	30 (mm)		50 (mm)	
		Ball screw	Lead screw	Ball screw	Lead screw
Ball screw	4	—	200	—	—
	2	—	100	—	—
Lead screw	1	—	50	—	—
	4	—	200	—	—
	2	—	100	—	—
	1	—	50	—	—

Code explanation ① Stroke ② Applicable controller ③ Cable length ④ Options \*See page A-71 for details on push motion. (Unit: mm/s)

#### ① Stroke

Stroke (mm)	Standard price	
	Ball screw	Lead screw
30	—	—
50	—	—

#### ③ Cable Length

Type	Cable symbol	Standard price
Standard (Robot Cables)	P (1m)	—
	S (3m)	—
	M (5m)	—
Special length	X06 (6m) ~ X10 (10m)	—
	X11 (11m) ~ X15 (15m)	—
	X16 (16m) ~ X20 (20m)	—
		—

\* The standard cable for the RCA2 is the robot cable.  
\* See page A-59 for cables for maintenance.

#### ④ Options

Name	Option code	See page	Standard price
Brake	B	→ A-42	—
Connector cable exits from the left	K1	→ A-51	—
Connector cable exits from the front	K2	→ A-51	—
Connector cable exits from the right	K3	→ A-51	—
Power-saving specification	LA	→ A-52	—

#### Actuator Specifications

Item	Description
Drive System	Ball screw/Lead screw, ø4mm, rolled C10
Lost Motion	Ball screw: 0.1mm or less
	Lead screw: 0.3mm or less (initial value)
Frame	Material: Aluminum, white alumite treated
Ambient operating temperature, humidity	0 to 40°C, 85% RH or less (Non-condensing)
Service life	Lead screw specification
	Ball screw specification

Dimensional Drawings

CAD drawings can be downloaded from the website. [www.intelligentactuator.com](http://www.intelligentactuator.com)

For Special Orders Appendix P.15

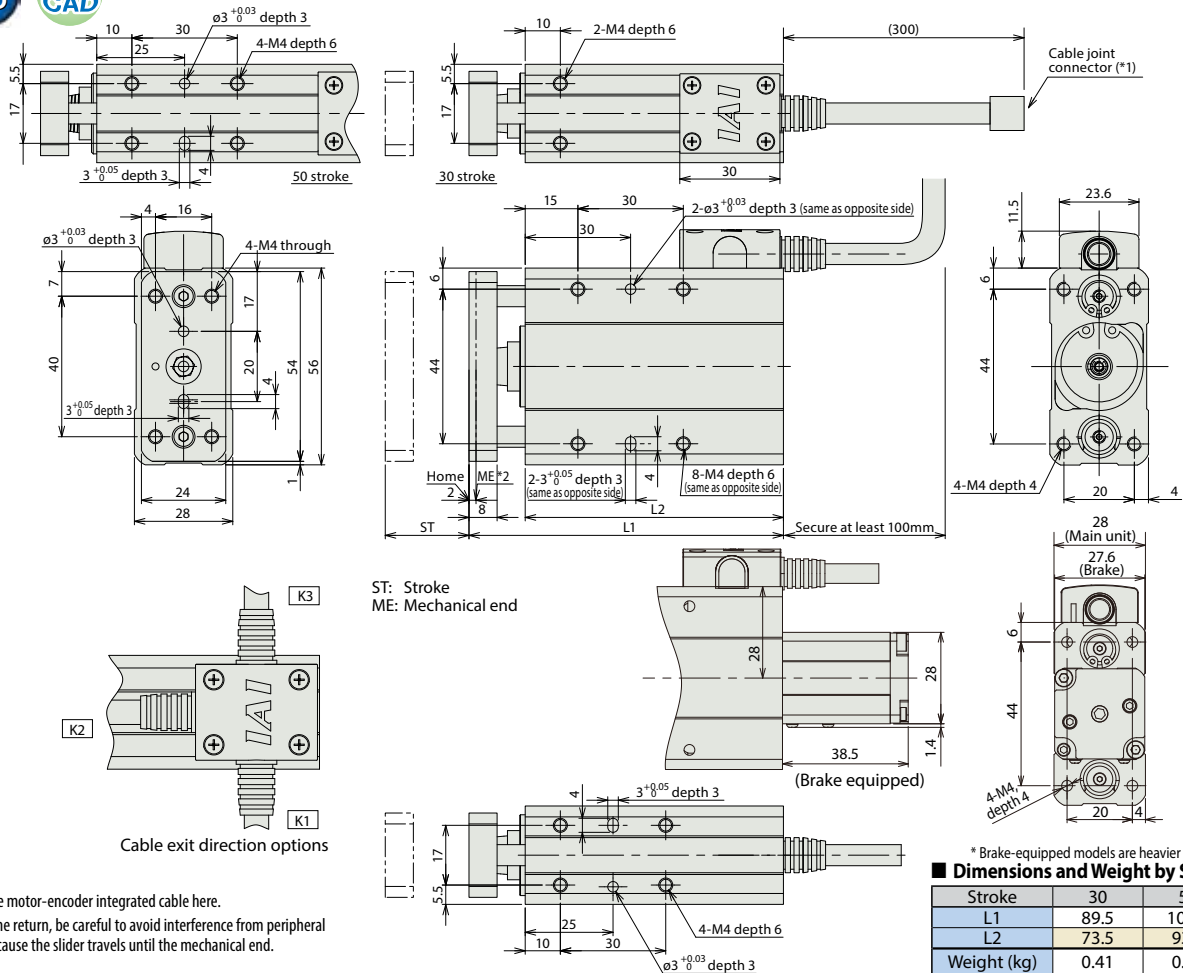

(\*1) Connect the motor-encoder integrated cable here.  
(\*2) During home return, be careful to avoid interference from peripheral objects because the slider travels until the mechanical end.

Applicable Controllers

RCA2 series actuators can be operated with the controllers indicated below. Select the type according to your intended application. \* ACON-CY also can be used.

Name	External view	Model number	Features	Maximum number of positioning points	Input power	Power-supply capacity	Standard price	Reference page
Solenoid Valve Type		AMEC-C-10I①②-2-1	Easy-to-use controller, even for beginners	3 points	AC100V	2.4A rated	—	→ P537
		ASEP-C-10I①②-2-0	Simple controller operable with the same signal as a solenoid valve					→ P547
Solenoid valve multi-axis type PIO specification		MSEP-C-③④⑤⑥⑦⑧⑨⑩-2-0	Positioner type based on PIO control, allowing up to 8 axes to be connected	256 points	DC24V	(Standard) 1.3A rated 4.4A max.	—	→ P563
Solenoid valve multi-axis type Network specification		MSEP-C-③④⑤⑥⑦⑧⑨⑩-0-0	Field network-ready positioner type, allowing up to 8 axes to be connected					→ P631
Positioner type		ACON-C-10I①②-2-0	Positioning is possible for up to 512 points	512 points	DC24V	(Power-saving) 1.3A rated 2.5A max.	—	→ P631
Safety-Compliant Positioner Type		ACON-CG-10I①②-2-0						
Pulse Train Input Type (Differential Line Driver)		ACON-PL-10I①②-2-0	Pulse train input type with differential line driver support	(—)	DC24V	(Power-saving) 1.3A rated 2.5A max.	—	→ P631
Pulse Train Input Type (Open Collector)		ACON-PO-10I①②-2-0	Pulse train input type with open collector support					
Serial Communication Type		ACON-SE-10I①-N-0-0	Dedicated Serial Communication	64 points	DC24V	(Power-saving) 1.3A rated 2.5A max.	—	→ P675
Program Control Type		ASEL-CS-1-10I①②-2-0	Programmed operation is possible. Can operate up to 2 axes	1,500 points	DC24V	(Power-saving) 1.3A rated 2.5A max.	—	→ P675

\* This is for the single-axis ASEL. \* Enter the code "LA" in ① when the power-saving specification is specified. \* ① indicates I/O type (NP/PN).  
\* ③ indicates number of axes (1 to 8). \* ④ indicates field network specification symbol.



RCA2-GD3NA



Toll Free Phone (877) SERV098  
Toll Free Fax (877) SERV099  
[www.electromate.com](http://www.electromate.com)  
[sales@electromate.com](mailto:sales@electromate.com)

- Slider Type
- Mini
- Standard
- Controller Integrated
- Rod Type
- Mini
- Standard
- Controllers Integrated
- Table/Arm/Flat Type
- Mini
- Standard
- Gripper/Rotary Type
- Linear Servo Type
- Clean-room Type
- Splash-Proof Type
- Pulse Motor
- Servo Motor (24V)
- Servo Motor (200V)
- Linear Servo Motor

# RCA2-GD4NA

Robo Cylinder, Mini Rod Type, Short-Length Double-Guide Type, Actuator Width 34mm, 24V Servo Motor, Ball Screw Specification/Lead Screw Specification

Model Specification Items	<b>RCA2</b>	<b>GD4NA</b>	<b>I</b>	<b>20</b>					
	Series	Type	Encoder type	Motor type	Lead	Stroke	Applicable controller	Cable length	Options
			I: Incremental * The Simple absolute encoder is also considered type "I".	20: 20W Servo motor	6: Ball screw 6mm 4: Ball screw 4mm 2: Ball screw 2mm 6S: Lead screw 6mm 4S: Lead screw 4mm 2S: Lead screw 2mm	30: 30mm 50: 50mm	A1: ACON ASEL A3: AMEC ASEP MSEP	N: None P: 1m S: 3m M: 5m X□□: Custom Length	See options below.

\* See page Pre-47 for details on the model descriptions.



Power-saving



Technical References Appendix P.5



- (1) The horizontal payload is the value when used in combination with a guide so that a radial load and moment load are not applied to the rod. Please refer to page A-111 for correlation diagrams of the end load and service life when a guide is not installed.
- (2) The payload is the value when the actuator is operated at an acceleration of 0.3 G (0.2G for lead 2, if used vertically and for lead screw specification). The acceleration limit is the value indicated above.
- (3) If the actuator is used vertically, pay attention to rod contact because the rod will come down when the power is turned off.
- (4) See page A-71 for details on push motion.

### Actuator Specifications

#### Leads and Payloads

Model number	Motor output (W)	Feed screw	Lead (mm)	Max. Load Capacity		Rated thrust (N)	Positioning Repeatability (mm)	Stroke (mm)
				Horizontal (kg)	Vertical (kg)			
RCA2-GD4NA-I-20-6-①-②-③-④	20	Ball screw	6	2	0.5	33.8	±0.02	30 50
RCA2-GD4NA-I-20-4-①-②-③-④			4	3	0.75	50.7		
RCA2-GD4NA-I-20-2-①-②-③-④			2	6	1.5	101.5		
RCA2-GD4NA-I-20-6S-①-②-③-④	20	Lead screw	6	0.25	0.125	19.9	±0.05	30 50
RCA2-GD4NA-I-20-4S-①-②-③-④			4	0.5	0.25	29.8		
RCA2-GD4NA-I-20-2S-①-②-③-④			2	1	0.5	59.7		

#### Stroke and Maximum Speed

Lead	Stroke	Maximum Speed	
		30 (mm)	50 (mm)
Ball screw	6	270 <220>	
	4	200	
	2	100	
Lead screw	6	220	300
	4	200	
	2	100	

Code explanation ① Stroke ② Applicable controller ③ Cable length ④ Options \*See page A-71 for details on push motion. \*The values enclosed in < > apply to vertical settings. (Unit: mm/s)

#### ① Stroke

Stroke (mm)	Standard price	
	Feed screw	
	Ball screw	Lead screw
30	—	—
50	—	—

#### ③ Cable Length

Type	Cable symbol	Standard price
Standard (Robot Cables)	P (1m)	—
	S (3m)	—
	M (5m)	—
Special length	X06 (6m) ~ X10 (10m)	—
	X11 (11m) ~ X15 (15m)	—
	X16 (16m) ~ X20 (20m)	—

\* The standard cable for the RCA2 is the robot cable.  
\* See page A-59 for cables for maintenance.

#### ④ Options

Name	Option code	See page	Standard price
Brake	B	→ A-42	—
Connector cable exits from the left	K1	→ A-51	—
Connector cable exits from the front	K2	→ A-51	—
Connector cable exits from the right	K3	→ A-51	—
Power-saving specification	LA	→ A-52	—

#### Actuator Specifications

Item	Description
Drive System	Ball screw/Lead screw, ø6mm, rolled C10
Lost Motion	Ball screw: 0.1mm or less
	Lead screw: 0.3mm or less (initial value)
Frame	Material: Aluminum, white alumite treated
Ambient operating temperature, humidity	0 to 40°C, 85% RH or less (Non-condensing)
Service life	Lead screw specification
	Ball screw specification

215 RCA2-GD4NA

Dimensional Drawings

CAD drawings can be downloaded from the website.

www.intelligentactuator.com



For Special Orders

Appendix P.15

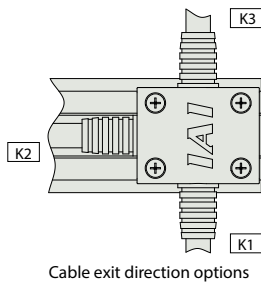
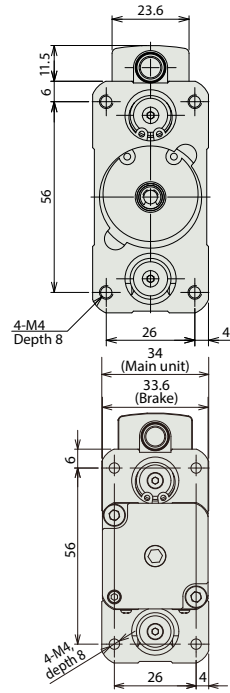
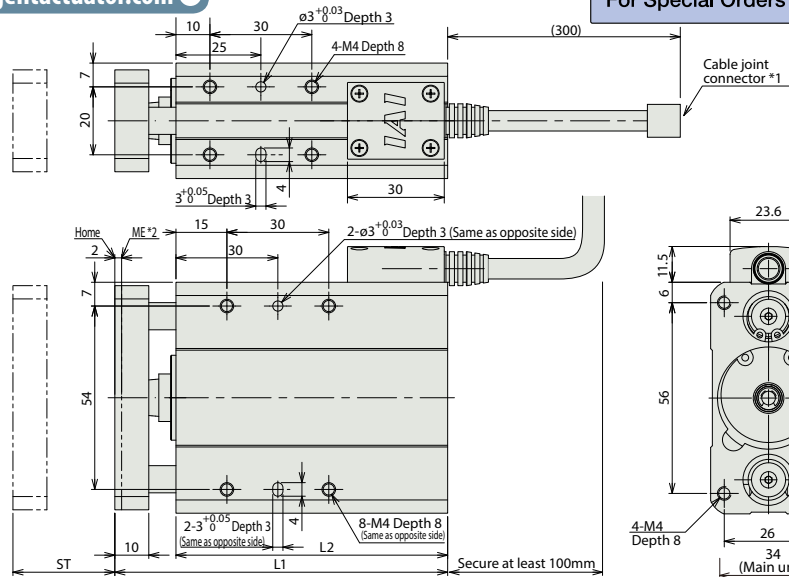
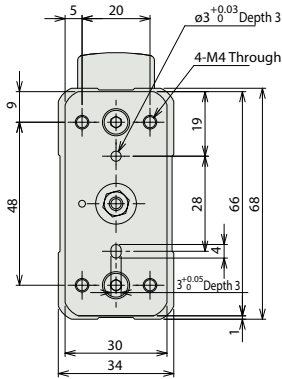

Cable exit direction options

ST: Stroke  
ME: Mechanical end

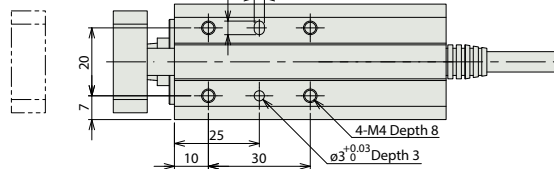
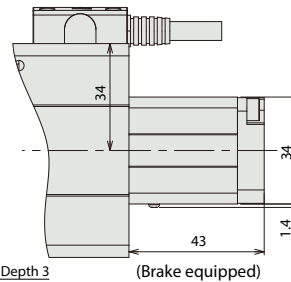

\* Brake-equipped models are heavier by 0.15kg.

Dimensions and Weight by Stroke

Stroke	30	50
L1	98	118
L2	80	100
Weight (kg)	0.64	0.76

(\*1) Connect the motor-encoder integrated cable here.  
(\*2) During home return, be careful to avoid interference from peripheral objects because the slider travels until the mechanical end.

Applicable Controllers

RCA2 series actuators can be operated with the controllers indicated below. Select the type according to your intended application. \* ACON-CY also can be used.

Name	External view	Model number	Features	Maximum number of positioning points	Input power	Power-supply capacity	Standard price	Reference page
Solenoid Valve Type		AMEC-C-20I-①-②-2-1	Easy-to-use controller, even for beginners	3 points	AC100V	2.4A rated	—	→ P537
		ASEP-C-20I-①-②-2-0	Simple controller operable with the same signal as a solenoid valve					→ P547
Solenoid valve multi-axis type PIO specification		MSEP-C-③-④-⑤-2-0	Positioner type based on PIO control, allowing up to 8 axes to be connected	256 points	DC24V	(Standard) 1.3A rated 4.4A max. (Power-saving) 1.3A rated 2.5A max.	—	→ P563
Solenoid valve multi-axis type Network specification		MSEP-C-③-④-⑤-0-0	Field network-ready positioner type, allowing up to 8 axes to be connected					→ P631
Positioner type		ACON-C-20I-①-②-2-0	Positioning is possible for up to 512 points	512 points	DC24V	(Standard) 1.3A rated 4.4A max. (Power-saving) 1.3A rated 2.5A max.	—	—
Safety-Compliant Positioner Type		ACON-CG-20I-①-②-2-0						
Pulse Train Input Type (Differential Line Driver)		ACON-PL-20I-①-②-2-0	Pulse train input type with differential line driver support	(—)	DC24V	(Standard) 1.3A rated 4.4A max. (Power-saving) 1.3A rated 2.5A max.	—	→ P631
Pulse Train Input Type (Open Collector)		ACON-PO-20I-①-②-2-0	Pulse train input type with open collector support					→ P675
Serial Communication Type		ACON-SE-20I-①-N-0-0	Dedicated Serial Communication	64 points	DC24V	(Standard) 1.3A rated 4.4A max. (Power-saving) 1.3A rated 2.5A max.	—	→ P675
Program Control Type		ASEL-CS-1-20I-①-②-2-0	Programmed operation is possible. Can operate up to 2 axes	1,500 points	DC24V	(Standard) 1.3A rated 4.4A max. (Power-saving) 1.3A rated 2.5A max.	—	→ P675

\* This is for the single-axis ASEL. \* Enter the code "LA" in ① when the power-saving specification is specified. \* ③ indicates I/O type (NP/PN).  
\* ④ indicates number of axes (1 to 8). \* ⑤ indicates field network specification symbol.



RCA2-GD4NA



Toll Free Phone (877) SERV098  
Toll Free Fax (877) SERV099  
www.electromate.com  
sales@electromate.com

Slider Type

Mini

Standard

Controller Integrated

Rod Type

Mini

Standard

Controller Integrated

Table/Arm/Flat Type

Mini

Standard

Gripper/Rotary Type

Linear Servo Type

Clean-room Type

Splash-Proof Type

Pulse Motor

Servo Motor (24V)

Servo Motor (200V)

Linear Servo Motor



# RCA2-SD3NA

Robo Cylinder, Mini Rod Type, Short-Length Double-Guide Slide Unit Type, Actuator  
Width 60mm, 24V Servo Motor, Ball Screw Specification/Lead Screw Specification

Model Specification Items	<b>RCA2</b> — <b>SD3NA</b> — <b>I</b> — <b>10</b> — <input type="checkbox"/> — <input type="checkbox"/> — <input type="checkbox"/> — <input type="checkbox"/> — <input type="checkbox"/>							
Series	Type	Encoder type	Motor type	Lead	Stroke	Applicable controller	Cable length	Options
I: Incremental * The Simple absolute encoder is also considered type "I".	10: 10W Servo motor	4: Ball screw 4mm 2: Ball screw 2mm 1: Ball screw 1mm 4S: Lead screw 4mm 2S: Lead screw 2mm 1S: Lead screw 1mm	25: 25mm 50: 50mm	A1: ACON ASEL A3: AMEC ASEP MSEP	N: None P: 1m S: 3m M: 5m X□□: Custom Length	See options below.		

\* See page Pre-47 for details on the model descriptions.



Power-saving

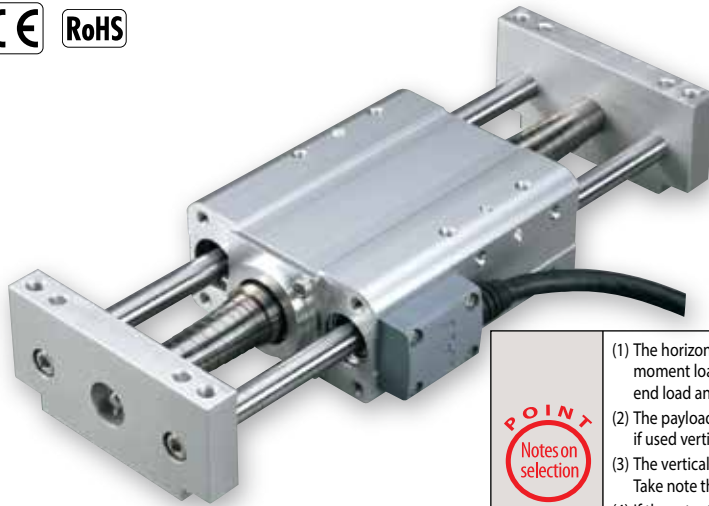

Technical References Appendix P.5



- (1) The horizontal payload is the value when used in combination with a guide so that a radial load and moment load are not applied to the rod. Please refer to page A-111 for correlation diagrams of the end load and service life when a guide is not installed.
- (2) The payload is the value when the actuator is operated at an acceleration of 0.3 G (0.2G for lead 1, if used vertically and for lead screw specification). The acceleration limit is the value indicated above.
- (3) The vertical payload is the value when the actuator is mounted and side bracket is operated. Take note that in vertical operation, the side bracket cannot be mounted to operate the actuator.
- (4) If the actuator is used vertically, pay attention to rod contact because the rod will come down when the power is turned off.
- (5) See page A-71 for details on push motion.

### Actuator Specifications

Leads and Payloads								Stroke and Maximum Speed			
Model number	Motor output (W)	Feed screw	Lead (mm)	Max. Load Capacity		Rated thrust (N)	Positioning Repeatability (mm)	Stroke (mm)	Stroke		
				Horizontal (kg)	Vertical (kg)				Lead	25 (mm)	50 (mm)
RCA2-SD3NA-I-10-4-①-②-③-④	10	Ball screw	4	0.75	0.25 (*1)	42.7	±0.02	25 50	Ball screw	4	200
RCA2-SD3NA-I-10-2-①-②-③-④			2	1.5	0.5 (*1)	85.5				2	100
RCA2-SD3NA-I-10-1-①-②-③-④			1	3	1 (*1)	170.9				1	50
RCA2-SD3NA-I-10-4S-①-②-③-④	10	Lead screw	4	0.25	0.125 (*1)	25.1	±0.05	25 50	Lead screw	4	200
RCA2-SD3NA-I-10-2S-①-②-③-④			2	0.5	0.25 (*1)	50.3				2	100
RCA2-SD3NA-I-10-1S-①-②-③-④			1	1	0.5 (*1)	100.5				1	50

Code explanation ① Stroke ② Applicable controller ③ Cable length ④ Options \*See page A-71 for details on push motion. (Unit: mm/s)

#### ① Stroke

Stroke (mm)	Standard price	
	Feed screw	
	Ball screw	Lead screw
25	—	—
50	—	—

#### ③ Cable Length

Type	Cable symbol	Standard price
Standard (Robot Cables)	P (1m)	—
	S (3m)	—
	M (5m)	—
Special length	X06 (6m) ~ X10 (10m)	—
	X11 (11m) ~ X15 (15m)	—
	X16 (16m) ~ X20 (20m)	—
		—

\* The standard cable for the RCA2 is the robot cable.  
\* See page A-59 for cables for maintenance.

#### ④ Options

Name	Option code	See page	Standard price
Connector cable exits from the left	K1	→ A-51	—
Connector cable exits from the right	K3	→ A-51	—
Power-saving specification	LA	→ A-52	—

#### Actuator Specifications

Item	Description
Drive System	Ball screw/Lead screw, ø4mm, rolled C10
Lost Motion	Ball screw: 0.1mm or less Lead screw: 0.3mm or less (initial value)
Frame	Material: Aluminum, white alumite treated
Ambient operating temperature, humidity	0 to 40°C, 85% RH or less (Non-condensing)
Service life	Lead screw specification
	Ball screw specification

Dimensional Drawings

CAD drawings can be downloaded from the website. [www.intelligentactuator.com](http://www.intelligentactuator.com)

For Special Orders Appendix P.15

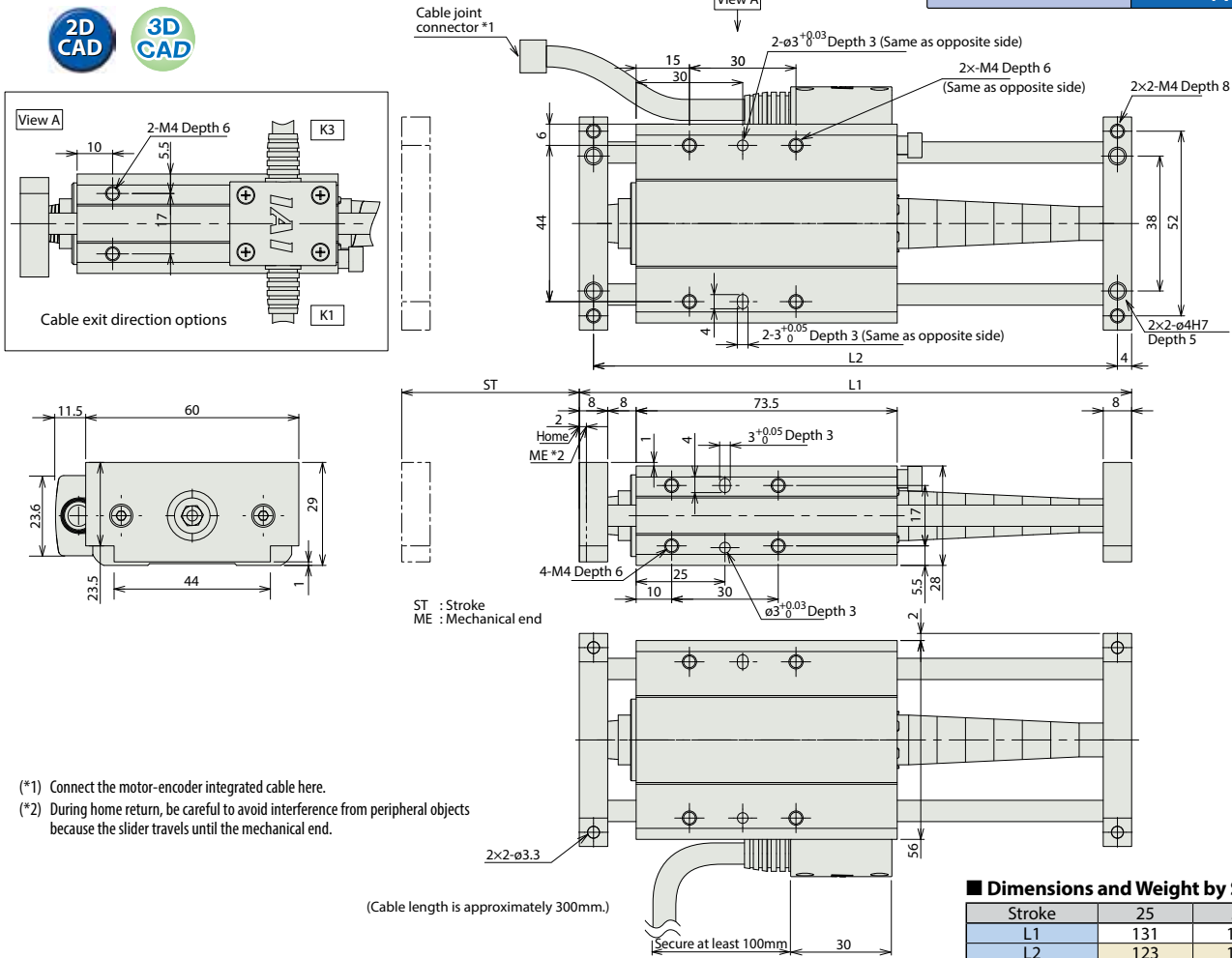

(\*1) Connect the motor-encoder integrated cable here.  
(\*2) During home return, be careful to avoid interference from peripheral objects because the slider travels until the mechanical end.

Applicable Controllers

RCA2 series actuators can be operated with the controllers indicated below. Select the type according to your intended application. \* ACON-CY also can be used.

Name	External view	Model number	Features	Maximum number of positioning points	Input power	Power-supply capacity	Standard price	Reference page
Solenoid Valve Type		AMEC-C-10I①-②-2-1	Easy-to-use controller, even for beginners	3 points	AC100V	2.4A rated	—	→ P537
		ASEP-C-10I①-②-2-0	Simple controller operable with the same signal as a solenoid valve					→ P547
Solenoid valve multi-axis type PIO specification		MSEP-C-③-④-⑤-2-0	Positioner type based on PIO control, allowing up to 8 axes to be connected	256 points	DC24V	(Standard) 1.3A rated 4.4A max. (Power-saving) 1.3A rated 2.5A max.	—	→ P563
Solenoid valve multi-axis type Network specification		MSEP-C-③-④-⑤-0-0	Field network-ready positioner type, allowing up to 8 axes to be connected					
Positioner type		ACON-C-10I①-②-2-0	Positioning is possible for up to 512 points	512 points	DC24V	(Standard) 1.3A rated 4.4A max. (Power-saving) 1.3A rated 2.5A max.	—	→ P631
Safety-Compliant Positioner Type		ACON-CG-10I①-②-2-0						
Pulse Train Input Type (Differential Line Driver)		ACON-PL-10I①-②-2-0	Pulse train input type with differential line driver support	(—)	DC24V	(Standard) 1.3A rated 4.4A max. (Power-saving) 1.3A rated 2.5A max.	—	→ P631
Pulse Train Input Type (Open Collector)		ACON-PO-10I①-②-2-0	Pulse train input type with open collector support					
Serial Communication Type		ACON-SE-10I①-N-0-0	Dedicated Serial Communication	64 points	DC24V	(Standard) 1.3A rated 4.4A max. (Power-saving) 1.3A rated 2.5A max.	—	→ P675
Program Control Type		ASEL-CS-1-10I①-②-2-0	Programmed operation is possible. Can operate up to 2 axes	1,500 points	DC24V	(Standard) 1.3A rated 4.4A max. (Power-saving) 1.3A rated 2.5A max.	—	→ P675

\* This is for the single-axis ASEL. \* Enter the code "LA" in ① when the power-saving specification is specified. \* ① indicates I/O type (NP/PN).  
\* ③ indicates number of axes (1 to 8). \* ④ indicates field network specification symbol.

- Slider Type
- Mini
- Standard
- Controller Integrated
- Rod Type
- Mini
- Standard
- Controllers Integrated
- Table/ Arm/ Flat Type
- Mini
- Standard
- Gripper/ Rotary Type
- Linear Servo Type
- Clean-room Type
- Splash-Proof Type
- Pulse Motor
- Servo Motor (24V)
- Servo Motor (200V)
- Linear Servo Motor

# RCA2-SD4NA

Robo Cylinder, Mini Rod Type, Short-Length Double-Guide Slide Unit Type, Actuator Width 72mm, 24V Servo Motor, Ball Screw Specification/Lead Screw Specification

Model Specification Items	<b>RCA2</b> — <b>SD4NA</b> — <b>I</b> — <b>20</b> — <input type="checkbox"/> — <input type="checkbox"/> — <input type="checkbox"/> — <input type="checkbox"/> — <input type="checkbox"/>	Series	Type	Encoder type	Motor type	Lead	Stroke	Applicable controller	Cable length	Options
	I: Incremental * The Simple absolute encoder is also considered type "I".	20: 20W Servo motor	6: Ball screw 6mm 4: Ball screw 4mm 2: Ball screw 2mm 6S: Lead screw 6mm 4S: Lead screw 4mm 2S: Lead screw 2mm	25: 25mm 50: 50mm 75: 75mm	A1: ACON ASEL A3: AMEC ASEP MSEP	N: None P: 1m S: 3m M: 5m X□□: Custom Length	See options below.			

\* See page Pre-47 for details on the model descriptions.



Power-saving

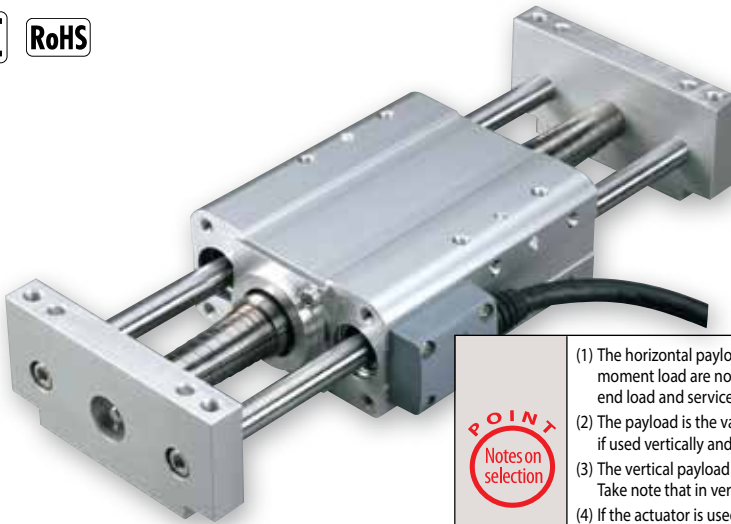

Technical References Appendix P.5

- POINT**  
Notes on selection
- (1) The horizontal payload is the value when used in combination with a guide so that a radial load and moment load are not applied to the rod. Please refer to page A-111 for correlation diagrams of the end load and service life when a guide is not installed.
  - (2) The payload is the value when the actuator is operated at an acceleration of 0.3 G (0.2G for 2mm-lead if used vertically and for lead screw specification). The acceleration limit is the value indicated above.
  - (3) The vertical payload is the value when the actuator is mounted and side bracket is operated. Take note that in vertical operation, the side bracket cannot be mounted to operate the actuator.
  - (4) If the actuator is used vertically, pay attention to rod contact because the rod will come down when the power is turned off.
  - (5) See page A-71 for details on push motion.

### Actuator Specifications

Leads and Payloads								Stroke and Maximum Speed				
Model number	Motor output (W)	Feed screw	Lead (mm)	Max. Load Capacity		Rated thrust (N)	Positioning Repeatability (mm)	Stroke (mm)	Stroke and Maximum Speed			
				Horizontal (kg)	Vertical (kg)				Lead	25 (mm)	50~75 (mm)	
RCA2-SD4NA-I-20-6-①-②-③-④	20	Ball screw	6	2	0.5 (*1)	33.8	±0.02	25 50 75	Ball screw	6	240 <200>	300
RCA2-SD4NA-I-20-4-①-②-③-④			4	3	0.75 (*1)	50.7				4	200	
RCA2-SD4NA-I-20-2-①-②-③-④			2	6	1.5 (*1)	101.5				2	100	
RCA2-SD4NA-I-20-6S-①-②-③-④	20	Lead screw	6	0.25	0.125 (*1)	19.9	±0.05	25 50 75	Lead screw	6	200	300
RCA2-SD4NA-I-20-4S-①-②-③-④			4	0.5	0.25 (*1)	29.8				4	200	
RCA2-SD4NA-I-20-2S-①-②-③-④			2	1	0.5 (*1)	59.7				2	100	

Code explanation ① Stroke ② Applicable controller ③ Cable length ④ Options \*See page A-71 for details on push motion. \*The values enclosed in < > apply to vertical settings. (Unit: mm/s)

#### ① Stroke

Stroke (mm)	Standard price	
	Feed screw	
	Ball screw	Lead screw
25	—	—
50	—	—
75	—	—

#### ③ Cable Length

Type	Cable symbol	Standard price
Standard (Robot Cables)	P (1m)	—
	S (3m)	—
	M (5m)	—
Special length	X06 (6m) ~ X10 (10m)	—
	X11 (11m) ~ X15 (15m)	—
	X16 (16m) ~ X20 (20m)	—

\* The standard cable for the RCA2 is the robot cable.  
\* See page A-59 for cables for maintenance.

#### ④ Options

Name	Option code	See page	Standard price
Connector cable exits from the left	K1	→ A-51	—
Connector cable exits from the right	K3	→ A-51	—
Power-saving specification	LA	→ A-52	—

#### Actuator Specifications

Item	Description
Drive System	Ball screw/Lead screw, ø6mm, rolled C10
Lost Motion	Ball screw: 0.1mm or less
	Lead screw: 0.3mm or less (initial value)
Frame	Material: Aluminum, white alumite treated
Ambient operating temperature, humidity	0 to 40°C, 85% RH or less (Non-condensing)
Service life	Lead screw specification
	Ball screw specification

Dimensional Drawings

CAD drawings can be downloaded from the website. [www.intelligentactuator.com](http://www.intelligentactuator.com)

For Special Orders Appendix P.15

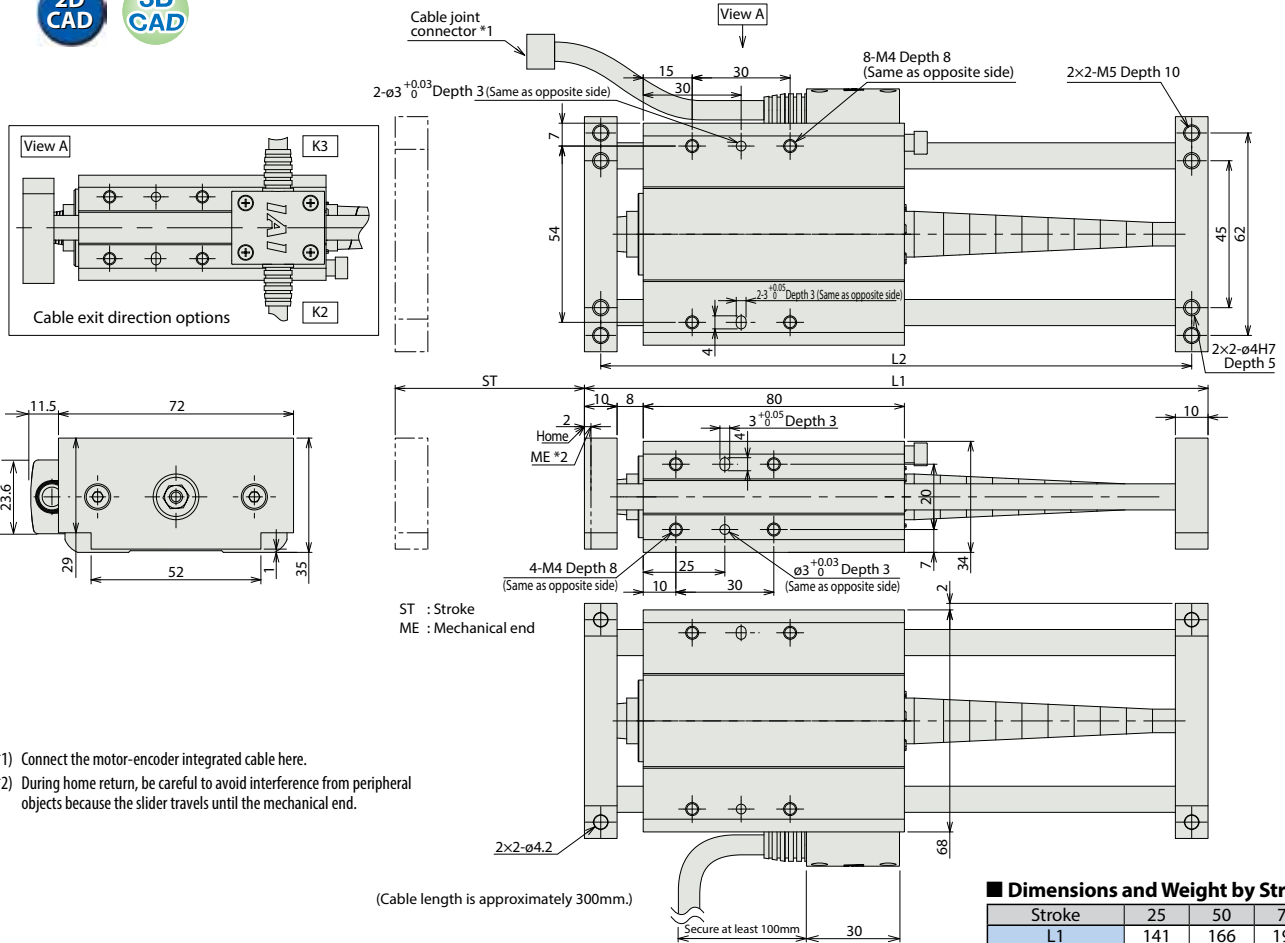

(\*1) Connect the motor-encoder integrated cable here.  
(\*2) During home return, be careful to avoid interference from peripheral objects because the slider travels until the mechanical end.

■ Dimensions and Weight by Stroke

Stroke	25	50	75
L1	141	166	191
L2	131	156	181
Weight (kg)	0.73	0.75	0.77

② Applicable Controllers

RCA2 series actuators can be operated with the controllers indicated below. Select the type according to your intended application. \* ACON-CY also can be used.

Name	External view	Model number	Features	Maximum number of positioning points	Input power	Power-supply capacity	Standard price	Reference page				
Solenoid Valve Type		AMEC-C-20I①-②-2-1	Easy-to-use controller, even for beginners	3 points	AC100V	2.4A rated	—	→ P537				
		ASEP-C-20I①-②-2-0	Simple controller operable with the same signal as a solenoid valve									
Solenoid valve multi-axis type PIO specification		MSEP-C-③-④-⑤-2-0	Positioner type based on PIO control, allowing up to 8 axes to be connected	256 points					DC24V	(Standard) 1.3A rated 4.4A max.	—	→ P563
Solenoid valve multi-axis type Network specification		MSEP-C-③-④-⑤-0-0	Field network-ready positioner type, allowing up to 8 axes to be connected	512 points								
Positioner type		ACON-C-20I①-②-2-0	Positioning is possible for up to 512 points	—					(Power-saving) 1.3A rated 2.5A max.	—	—	→ P631
Safety-Compliant Positioner Type		ACON-CG-20I①-②-2-0										
Pulse Train Input Type (Differential Line Driver)		ACON-PL-20I①-②-2-0	Pulse train input type with differential line driver support	(—)					—	—	—	—
Pulse Train Input Type (Open Collector)		ACON-PO-20I①-②-2-0	Pulse train input type with open collector support									
Serial Communication Type		ACON-SE-20I①-N-0-0	Dedicated Serial Communication	64 points	—	—	—	—				
Program Control Type		ASEL-CS-1-20I①-②-2-0	Programmed operation is possible. Can operate up to 2 axes	1,500 points	—	—	—	→ P675				

\* This is for the single-axis ASEL. \* Enter the code "LA" in ① when the power-saving specification is specified. \* ③ indicates I/O type (NP/PN).  
\* ③ indicates number of axes (1 to 8). \* ④ indicates field network specification symbol.

# RCA-RA3C

Robo Cylinder, Rod Type, ø32mm Diameter, 24V Servo Motor, Coupled

Model Specification Items	<b>RCA</b> — <b>RA3C</b> — <b>I</b> — <b>20</b> — <input type="checkbox"/> — <input type="checkbox"/> — <input type="checkbox"/> — <input type="checkbox"/> — <input type="checkbox"/>	Series — Type — Encoder type — Motor type — Lead — Stroke — Applicable controller — Cable length — Options
	I: Incremental * The Simple absolute encoder is also considered type "I".	20: 20W Servo motor
	10: 10mm 5: 5mm 2.5: 2.5mm	50: 50mm { 200: 200mm (50mm pitch increments)
	A1: ASEP MSEP A3: AMEC ASEP MSEP	N: None P: 1m S: 3m M: 5m X <input type="checkbox"/> : Custom Length R <input type="checkbox"/> : Robot Cable
	See Options below.	

\* See page Pre-47 for details on the model descriptions.



**For High Acceleration/Deceleration**

**Power-saving**

(excluding the 2.5-mm lead model)

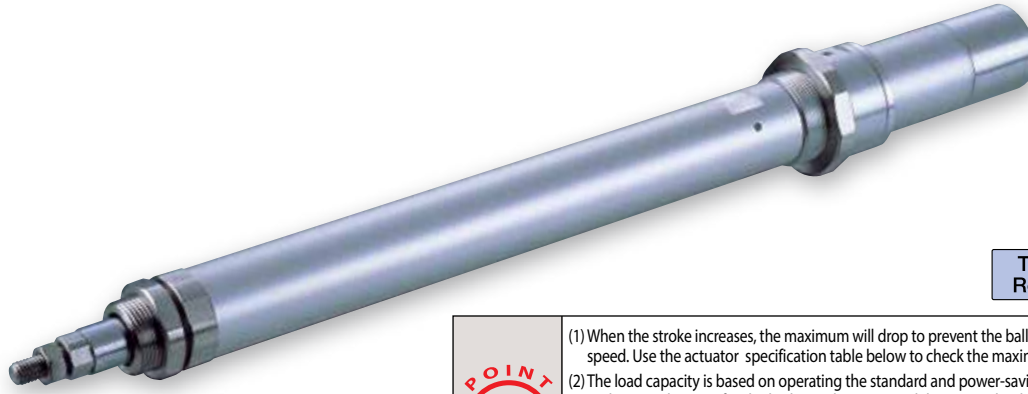

Technical References Appendix P.5



- (1) When the stroke increases, the maximum will drop to prevent the ball screw from reaching the critical rotational speed. Use the actuator specification table below to check the maximum speed at the stroke you desire.
- (2) The load capacity is based on operating the standard and power-saving models at 0.3G (0.2G for 2.5mm-lead), and 1G acceleration for the high-acceleration models (2.5mm-lead model excluded). (The values in the table below are the upper limits, even if the acceleration/deceleration is decreased.)
- (3) The values for the horizontal load capacity assume the use of an external guide, so that there is no external force from any direction other than the forward/backward direction of the rod.
- (4) See page A-71 for details on push motion.

### Actuator Specifications

#### Leads and Payloads

Model number	Motor output (W)	Lead (mm)	Max. Load Capacity		Rated thrust (N)	Stroke (mm)
			Horizontal (kg)	Vertical (kg)		
RCA-RA3C-I-20-10-①-②-③-④	20	10	4.0	1.5	36.2	50~200 (every 50mm)
RCA-RA3C-I-20-5-①-②-③-④		5	9.0	3.0	72.4	
RCA-RA3C-I-20-2.5-①-②-③-④		2.5	18.0	6.5	144.8	

#### Stroke and Maximum Speed

Lead	Stroke	50~200 (every 50mm)
	10	500
5	250	250
2.5	125	125

Code explanation ① Stroke ② Applicable controller ③ Cable length ④ Options \*See page A-71 for details on push motion. (Unit: mm/s)

#### ① Stroke

① Stroke (mm)	Standard price
50	—
100	—
150	—
200	—

#### ④ Options

Name	Option code	See page	Standard price
Brake	<b>B</b>	→ A-42	—
Foot bracket	<b>FT</b>	→ A-49	—
Flange bracket (front)	<b>FL</b>	→ A-45	—
Flange bracket (back)	<b>FLR</b>	→ A-46	—
High-acceleration/deceleration (*1)	<b>HA</b>	→ A-50	—
Home sensor (*2)	<b>HS</b>	→ A-50	—
Power-saving (*3)	<b>LA</b>	→ A-52	—
Knuckle joint	<b>NJ</b>	→ A-53	—
Non-motor end specification	<b>NM</b>	→ A-52	—
Trunnion bracket (front)	<b>TRF</b>	→ A-57	—
Trunnion bracket (back)	<b>TRR</b>	→ A-58	—

(\*1) The high-acceleration/deceleration option is not available for 2.5mm-lead model.  
 (\*2) The home sensor (HS) cannot be used on the Non-motor end models.  
 (\*3) The high-acceleration/deceleration option and the power-saving option cannot be used simultaneously.

#### ③ Cable Length

Type	Cable symbol	Standard Price
Standard	<b>P</b> (1m)	—
	<b>S</b> (3m)	—
	<b>M</b> (5m)	—
Special length	<b>X06</b> (6m) ~ <b>X10</b> (10m)	—
	<b>X11</b> (11m) ~ <b>X15</b> (15m)	—
	<b>X16</b> (16m) ~ <b>X20</b> (20m)	—
Robot Cable	<b>R01</b> (1m) ~ <b>R03</b> (3m)	—
	<b>R04</b> (4m) ~ <b>R05</b> (5m)	—
	<b>R06</b> (6m) ~ <b>R10</b> (10m)	—
	<b>R11</b> (11m) ~ <b>R15</b> (15m)	—
	<b>R16</b> (16m) ~ <b>R20</b> (20m)	—

\* See page A-59 for cables for maintenance.

### Actuator Specifications

Item	Description
Drive System	Ball screw, ø8mm, rolled C10
Positioning Repeatability	±0.02mm
Lost Motion	0.1mm or less
Base	Material: Aluminum, white alumite treated
Rod diameter	ø16mm
Non-rotating accuracy of rod	±1.0 deg
Ambient operating temperature, humidity	0 to 40°C, 85% RH or less (Non-condensing)

Dimensional Drawings

CAD drawings can be downloaded from the website.

www.intelligentactuator.com

For Special Orders

Appendix P.15



- (\*1) Connect the motor and encoder cables here. See page A-59 for details on cables.
- (\*2) After homing, the slider moves to the ME, therefore, please watch for any interference with surrounding objects.  
ME: Mechanical end SE: Stroke end
- (\*3) The orientation of the bolt varies depending on the product.

[No Brake]

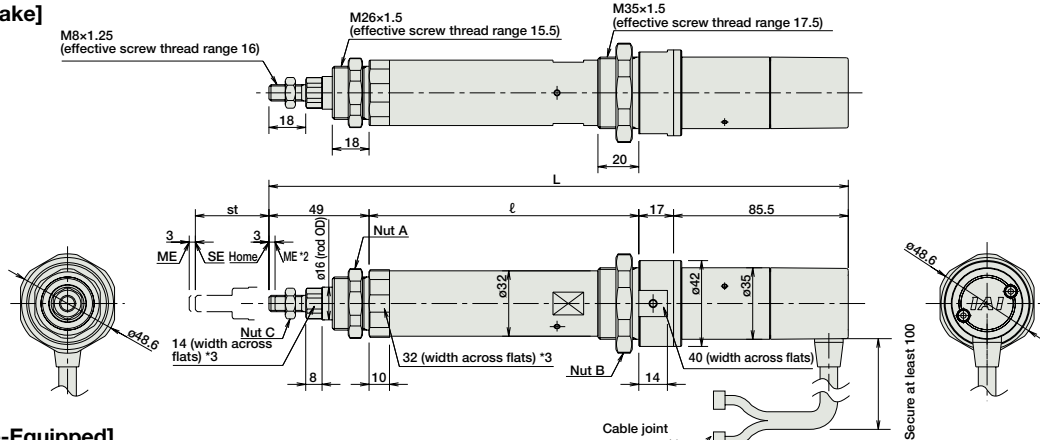

[Brake-Equipped]

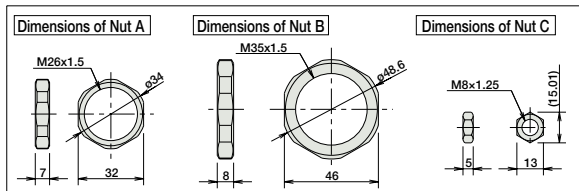
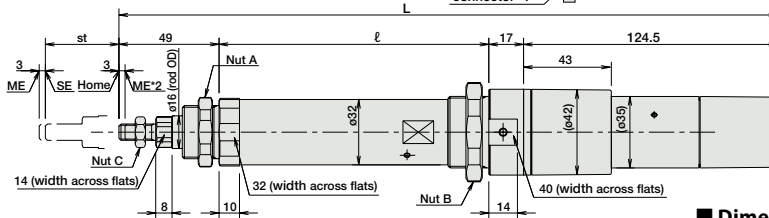

Note:  
Do not apply any external force on the rod from any direction other than the direction of the rod's motion. If a force is exerted on the rod in a perpendicular or rotational direction, the detent may become damaged.

Dimensions and Weight by Stroke  
RCA-RA3C (without brake)

Stroke	50	100	150	200
L	283.5	333.5	383.5	433.5
ℓ	132	182	232	282
Weight (kg)	0.7	0.8	0.9	1.0

RCA-RA3C (with brake)

Stroke	50	100	150	200
L	322.5	372.5	422.5	472.5
ℓ	132	182	232	282
Weight (kg)	0.9	1.0	1.1	1.2

Applicable Controllers

RCA series actuators can be operated with the controllers indicated below. Select the type according to your intended application. \* ACON-CY also can be used.

Name	External view	Model number	Features	Maximum number of positioning points	Input power	Power-supply capacity	Standard price	Reference page
Solenoid Valve Type		AMEC-C-20SI①-②-2-1	Easy-to-use controller, even for beginners	3 points	AC100V	2.4A rated	—	→ P537
		ASEP-C-20SI①-②-2-0	Simple controller operable with the same signal as a solenoid valve					→ P547
Solenoid valve multi-axis type PIO specification		MSEP-C-③-④-⑤-2-0	Positioner type based on PIO control, allowing up to 8 axes to be connected	256 points	DC24V	(Standard) 1.7A rated 5.1A max.	—	→ P563
Solenoid valve multi-axis type Network specification		MSEP-C-③-④-⑤-0-0	Field network-ready positioner type, allowing up to 8 axes to be connected					
Positioner type		ACON-C-20SI①-②-2-0	Positioning is possible for up to 512 points	512 points	DC24V	(Power-saving) 1.7A rated 3.4A max.	—	→ P631
Safety-Compliant Positioner Type		ACON-CG-20SI①-②-2-0						
Pulse Train Input Type (Differential Line Driver)		ACON-PL-20SI①-②-2-0	Pulse train input type with differential line driver support	(—)	DC24V	(Power-saving) 1.7A rated 3.4A max.	—	→ P631
Pulse Train Input Type (Open Collector)		ACON-PO-20SI①-②-2-0	Pulse train input type with open collector support					
Serial Communication Type		ACON-SE-20SI①-N-0-0	Dedicated Serial Communication	64 points	DC24V	(Power-saving) 1.7A rated 3.4A max.	—	→ P675
Program Control Type		ASEL-CS-1-20SI①-②-2-0	Programmed operation is possible. Can operate up to 2 axes	1,500 points	DC24V	(Power-saving) 1.7A rated 3.4A max.	—	→ P675

\* This is for the single-axis ASEL. \* Enter the code "HA" or "LA" in ① when the high-acceleration/deceleration option or the power-saving option is specified.  
 \* ① indicates I/O type (NP/PN). \* ③ indicates number of axes (1 to 8). \* ④ indicates field network specification symbol.

# RCA-RA4C

Robo Cylinder, Rod Type, ø37mm Diameter, 24V Servo Motor, Coupled

Model Specification Items	<b>RCA</b>	<b>RA4C</b>							
	Series	Type	Encoder type	Motor type	Lead	Stroke	Applicable controller	Cable length	Options
	I: Incremental A: Absolute	20: 20W Servo motor 30: 30W Servo motor			12: 12mm 6: 6mm 3: 3mm	50: 50mm 300: 300mm (50mm pitch increments)	A1: ACON ASEL A3: AMEC ASEP MSEP	N: None P: 1m S: 3m M: 5m X□□: Custom Length R□□: Robot Cable	See Options below.

\* See page Pre-47 for details on the model descriptions.  
\* The absolute models are only compatible with ASEL. Simple absolute encoders are considered incremental.



**For High Acceleration/Deceleration**

**Power-saving**

(\*1) Except all 20W models and 30W 3mm lead models

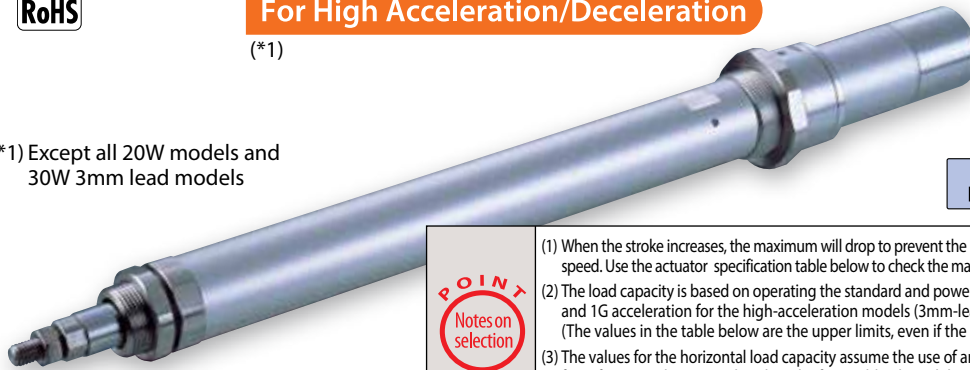

Technical References Appendix P.5



- (1) When the stroke increases, the maximum will drop to prevent the ball screw from reaching the critical rotational speed. Use the actuator specification table below to check the maximum speed at the stroke you desire.
- (2) The load capacity is based on operating the standard and power-saving models at 0.3G (0.2G for 3mm-lead), and 1G acceleration for the high-acceleration models (3mm-lead model excluded). (The values in the table below are the upper limits, even if the acceleration/deceleration is decreased.)
- (3) The values for the horizontal load capacity assume the use of an external guide, so that there is no external force from any direction other than the forward/backward direction of the rod.
- (4) See page A-71 for details on push motion.

### Actuator Specifications

#### Leads and Payloads

Model number	Motor output (W)	Lead (mm)	Max. Load Capacity		Rated thrust (N)	Stroke (mm)
			Horizontal (kg)	Vertical (kg)		
RCA-RA4C-①-20-12-②-③-④-⑤	20	12	3.0	1.0	18.9	50~300 (every 50mm)
RCA-RA4C-①-20-6-②-③-④-⑤		6	6.0	2.0	37.7	
RCA-RA4C-①-20-3-②-③-④-⑤		3	12.0	4.0	75.4	
RCA-RA4C-①-30-12-②-③-④-⑤	30	12	4.0	1.5	28.3	
RCA-RA4C-①-30-6-②-③-④-⑤		6	9.0	3.0	56.6	
RCA-RA4C-①-30-3-②-③-④-⑤		3	18.0	6.5	113.1	

#### Stroke and Maximum Speed

Stroke Lead	Stroke	50~300 (every 50mm)
	12	600
6	300	300
3	150	150

(Unit: mm/s)

Code explanation ① Stroke ② Applicable controller ③ Cable length ④ Options \*See page A-71 for details on push motion.

#### ① Encoder Type/② Stroke

② Stroke (mm)	Standard price			
	① Encoder Type			
	Incremental		Absolute	
	Motor Output (W)		Motor Output (W)	
	20W	30W	20W	30W
50	—	—	—	—
100	—	—	—	—
150	—	—	—	—
200	—	—	—	—
250	—	—	—	—
300	—	—	—	—

#### ⑤ Options

Name	Option code	See page	Standard price
Brake	<b>B</b>	→ A-42	—
Foot bracket	<b>FT</b>	→ A-49	—
Flange bracket (front)	<b>FL</b>	→ A-45	—
Flange bracket (back)	<b>FLR</b>	→ A-46	—
High-acceleration/deceleration (*1)	<b>HA</b>	→ A-50	—
Home sensor (*2)	<b>HS</b>	→ A-50	—
Power-saving (*3)	<b>LA</b>	→ A-52	—
Knuckle joint	<b>NJ</b>	→ A-53	—
Non-motor end specification	<b>NM</b>	→ A-52	—
Trunnion bracket (front)	<b>TRF</b>	→ A-57	—
Trunnion bracket (back)	<b>TRR</b>	→ A-58	—

(\*1) The high-acceleration/deceleration option is not available for all the 20W models, not 30W with 3mm-lead model.  
(\*2) The home sensor (HS) cannot be used on the Non-motor end models.  
(\*3) The high-acceleration/deceleration option and the power-saving option cannot be used simultaneously.

#### ④ Cable Length

Type	Cable symbol	Standard Price
Standard	<b>P</b> (1m)	—
	<b>S</b> (3m)	—
	<b>M</b> (5m)	—
Special length	<b>X06</b> (6m) ~ <b>X10</b> (10m)	—
	<b>X11</b> (11m) ~ <b>X15</b> (15m)	—
	<b>X16</b> (16m) ~ <b>X20</b> (20m)	—
Robot Cable	<b>R01</b> (1m) ~ <b>R03</b> (3m)	—
	<b>R04</b> (4m) ~ <b>R05</b> (5m)	—
	<b>R06</b> (6m) ~ <b>R10</b> (10m)	—
	<b>R11</b> (11m) ~ <b>R15</b> (15m)	—
	<b>R16</b> (16m) ~ <b>R20</b> (20m)	—

\* See page A-59 for cables for maintenance.

### Actuator Specifications

Item	Description
Drive System	Ball screw, ø10mm, rolled C10
Positioning Repeatability	±0.02mm
Lost Motion	0.1mm or less
Base	Material: Aluminum, white alumite treated
Rod diameter	ø20mm
Non-rotating accuracy of rod	±1.0 deg
Ambient operating temperature, humidity	0 to 40°C, 85% RH or less (Non-condensing)

Dimensional Drawings

CAD drawings can be downloaded from the website.

www.intelligentactuator.com

For Special Orders

Appendix P.15



- (\*1) Connect the motor and encoder cables here. See page A-59 for details on cables.
- (\*2) After homing, the slider moves to the ME, therefore, please watch for any interference with surrounding objects.  
ME: Mechanical end SE: Stroke end
- (\*3) The orientation of the bolt varies depending on the product.

Note:  
Do not apply any external force on the rod from any direction other than the direction of the rod's motion. If a force is exerted on the rod in a perpendicular or rotational direction, the detent may become damaged.

[No Brake]

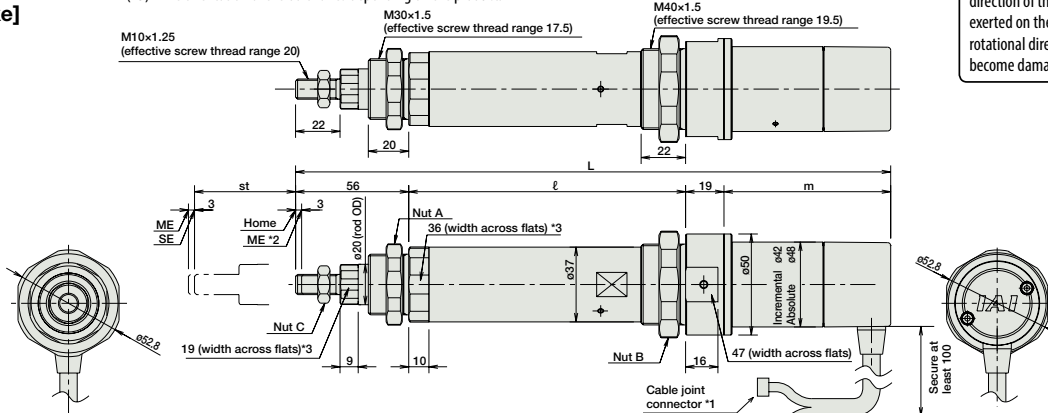

[Brake-Equipped]

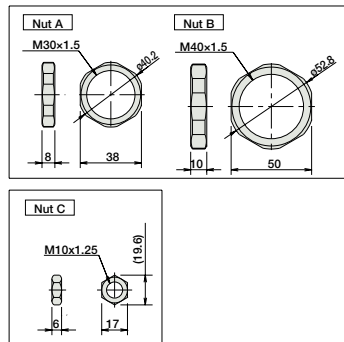
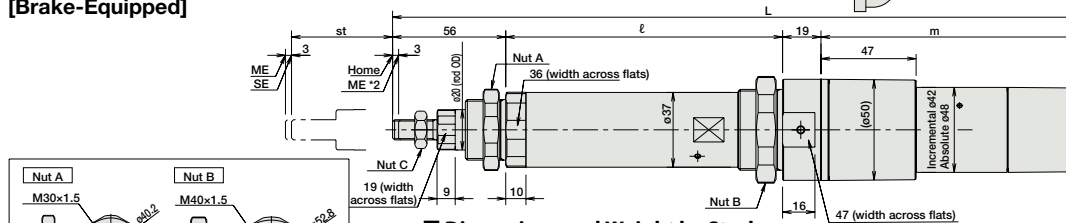

Dimensions and Weight by Stroke

RCA-RA4C (without brake)

Stroke	RCA-RA4C (without brake)						
	50	100	150	200	250	300	
L	Increm.	279.5	329.5	379.5	429.5	479.5	529.5
	Absol.	292.5	342.5	392.5	442.5	492.5	542.5
L	Increm.	294.5	344.5	394.5	444.5	494.5	544.5
	Absol.	307.5	357.5	407.5	457.5	507.5	557.5
ℓ		137	187	237	287	337	387
m	Increm.	67.5					
	Absol.	80.5					
m	Increm.	82.5					
	Absol.	95.5					
Weight (kg)		1.1	1.2	1.4	1.5	1.7	1.8

RCA-RA4C (with brake)

Stroke	RCA-RA4C (with brake)						
	50	100	150	200	250	300	
L	Increm.	322.5	372.5	422.5	472.5	522.5	572.5
	Absol.	335.5	385.5	435.5	485.5	535.5	585.5
L	Increm.	337.5	387.5	437.5	487.5	537.5	587.5
	Absol.	350.5	400.5	450.5	500.5	550.5	600.5
ℓ		137	187	237	287	337	387
m	Increm.	110.5					
	Absol.	123.5					
m	Increm.	125.5					
	Absol.	138.5					
Weight (kg)		1.3	1.4	1.6	1.7	1.9	2.0

Applicable Controllers

RCA series actuators can be operated with the controllers indicated below. Select the type according to your intended application. \* ACON-CY also can be used.

Name	External view	Model number	Features	Maximum number of positioning points	Input power	Power-supply capacity	Standard price	Reference page
Solenoid Valve Type		AMEC-C-20I(①)-(②)-2-1 AMEC-C-30I(①)-(②)-2-1	Easy-to-use controller, even for beginners	3 points	AC100V	2.4A rated	—	→ P537
		ASEP-C-20I(①)-(②)-2-0 ASEP-C-30I(①)-(②)-2-0	Simple controller operable with the same signal as a solenoid valve					
Solenoid valve multi-axis type PIO specification		MSEP-C-IV-~-(③)-2-0	Positioner type based on PIO control, allowing up to 8 axes to be connected	256 points	DC24V	(Standard) 20W 1.3A rated 4.4A max. 30W 1.3A rated 4.4A max.	—	→ P563
Solenoid valve multi-axis type Network specification		MSEP-C-IV-~-(④)-0-0	Field network-ready positioner type, allowing up to 8 axes to be connected					
Positioner type		ACON-C-20I(①)-(②)-2-0 ACON-C-30I(①)-(②)-2-0	Positioning is possible for up to 512 points	512 points	DC24V	(Power-saving) 20W 1.3A rated 2.5A max. 30W 1.3A rated 2.2A max.	—	→ P631
Safety-Compliant Positioner Type		ACON-CG-20I(①)-(②)-2-0 ACON-CG-30I(①)-(②)-2-0						
Pulse Train Input Type (Differential Line Driver)		ACON-PL-20I(①)-(②)-2-0 ACON-PL-30I(①)-(②)-2-0	Pulse train input type with differential line driver support	(—)	DC24V	(Power-saving) 20W 1.3A rated 2.5A max. 30W 1.3A rated 2.2A max.	—	→ P631
Pulse Train Input Type (Open Collector)		ACON-PO-20I(①)-(②)-2-0 ACON-PO-30I(①)-(②)-2-0	Pulse train input type with open collector support					
Serial Communication Type		ACON-SE-20I(①)-N-0-0 ACON-SE-30I(①)-N-0-0	Dedicated Serial Communication	64 points	DC24V	(Power-saving) 20W 1.3A rated 2.5A max. 30W 1.3A rated 2.2A max.	—	→ P675
Program Control Type		ASEL-CS-1-20I(①)-(②)-2-0 ASEL-CS-1-30I(①)-(②)-2-0	Programmed operation is possible. Can operate up to 2 axes	1,500 points	DC24V	(Power-saving) 20W 1.3A rated 2.5A max. 30W 1.3A rated 2.2A max.	—	→ P675

\* This is for the single-axis ASEL. \* ① indicates encoder type (I: incremental, A: absolute) \* Enter the code "HA" or "LA" in ② when the high-acceleration/deceleration option or the power-saving option is specified. \* ③ indicates I/O type (NP/PN). \* ④ indicates number of axes (1 to 8). \* ⑤ indicates field network specification symbol.



# RCA-RA3D

Robo Cylinder, Rod Type, ø32mm Diameter, 24V Servo Motor, Built-In (Direct-Coupled) Motor

Model Specification Items	<b>RCA</b>	<b>— RA3D</b>	<b>— I</b>	<b>— 20</b>	<input type="checkbox"/>	<input type="checkbox"/>	<input type="checkbox"/>	<input type="checkbox"/>	<input type="checkbox"/>
	Series	Type	Encoder type	Motor type	Lead	Stroke	Applicable controller	Cable length	Options
			I: Incremental * The Simple absolute encoder is also considered type "I".	20: 20W Servo motor	10: 10mm 5: 5mm 2.5: 2.5mm	50: 50mm { 200: 200mm (50mm pitch increments)	A1: ACON ASEL A3: AMEC ASEP MSEP	N: None P: 1m S: 3m M: 5m X□□: Custom Length R□□: Robot Cable	See Options below.

\* See page Pre-47 for details on the model descriptions.



Power-saving

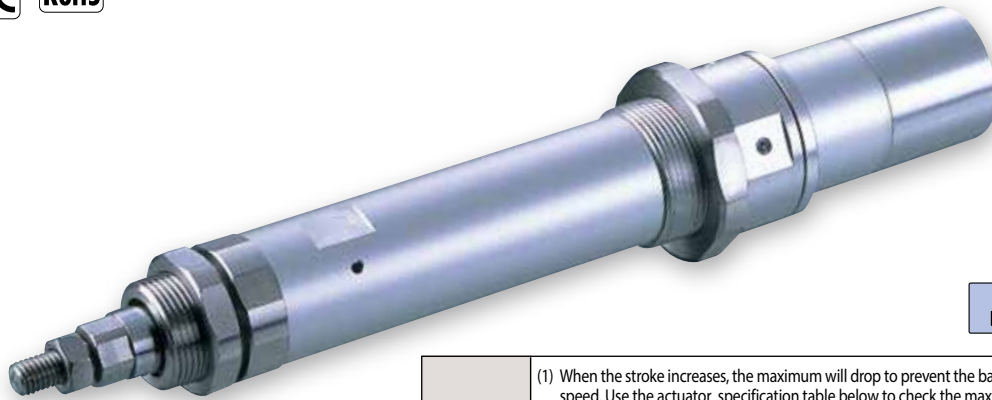

Technical References Appendix P.5

- POINT**  
Notes on selection
- (1) When the stroke increases, the maximum will drop to prevent the ball screw from reaching the critical rotational speed. Use the actuator specification table below to check the maximum speed at the stroke you desire.
  - (2) The load capacity is based on operation at an acceleration of 0.3G (0.2G for 2.5mm-lead model). These values are the upper limits for the acceleration.
  - (3) The values for the horizontal load capacity assume the use of an external guide, so that there is no external force from any direction other than the forward/backward direction of the rod.
  - (4) Please note that there is no brake option for the motor built-in specification.
  - (5) See page A-71 for details on push motion.

## Actuator Specifications

### Leads and Payloads

Model number	Motor output (W)	Lead (mm)	Max. Load Capacity		Rated thrust (N)	Stroke (mm)
			Horizontal (kg)	Vertical (kg)		
RCA-RA3D-I-20-10-①-②-③-④	20	10	4.0	1.5	36.2	50~200 (every 50mm)
RCA-RA3D-I-20-5-①-②-③-④		5	9.0	3.0	72.4	
RCA-RA3D-I-20-2.5-①-②-③-④		2.5	18.0	6.5	144.8	

### Stroke and Maximum Speed

Lead	Stroke	50~200 (every 50mm)
	10	500
5	250	250
2.5	125	125

Code explanation ① Stroke ② Applicable controller ③ Cable length ④ Options \*See page A-71 for details on push motion. (Unit: mm/s)

### ① Stroke

① Stroke (mm)	Standard price
50	—
100	—
150	—
200	—

### ③ Cable Length

Type	Cable symbol	Standard Price
Standard	P (1m)	—
	S (3m)	—
	M (5m)	—
Special length	X06 (6m) ~ X10 (10m)	—
	X11 (11m) ~ X15 (15m)	—
	X16 (16m) ~ X20 (20m)	—
Robot Cable	R01 (1m) ~ R03 (3m)	—
	R04 (4m) ~ R05 (5m)	—
	R06 (6m) ~ R10 (10m)	—
	R11 (11m) ~ R15 (15m)	—
	R16 (16m) ~ R20 (20m)	—

\* See page A-59 for cables for maintenance.

### ④ Options

Name	Option code	See page	Standard price
Foot bracket	FT	→ A-49	—
Flange bracket (front)	FL	→ A-45	—
Flange bracket (back)	FLR	→ A-46	—
Home sensor	HS	→ A-50	—
Power-saving	LA	→ A-52	—
Knuckle joint	NJ	→ A-53	—
Non-motor end specification	NM	→ A-52	—
Trunnion bracket (front)	TRF	→ A-57	—
Trunnion bracket (back)	TRR	→ A-58	—

\*The home sensor (HS) cannot be used on the Non-motor end models.

### Actuator Specifications

Item	Description
Drive System	Ball screw, ø8mm, rolled C10
Positioning Repeatability	±0.02mm
Lost Motion	0.1mm or less
Base	Material: Aluminum, white alumite treated
Rod diameter	ø16mm
Non-rotating accuracy of rod	±1.0 deg
Ambient operating temperature, humidity	0 to 40°C, 85% RH or less (Non-condensing)

225 RCA-RA3D

Dimensional Drawings

CAD drawings can be downloaded from the website. [www.intelligentactuator.com](http://www.intelligentactuator.com)

For Special Orders Appendix P.15



- (\*1) Connect the motor and encoder cables here. See page A-59 for details on cables.
- (\*2) After homing, the slider moves to the ME, therefore, please watch for any interference with surrounding objects.  
ME : Mechanical end  
SE : Stroke end
- (\*3) The orientation of the bolt varies depending on the product.

[No Brake]

Note:  
Do not apply any external force on the rod from any direction other than the direction of the rod's motion. If a force is exerted on the rod in a perpendicular or rotational direction, the detent may become damaged.

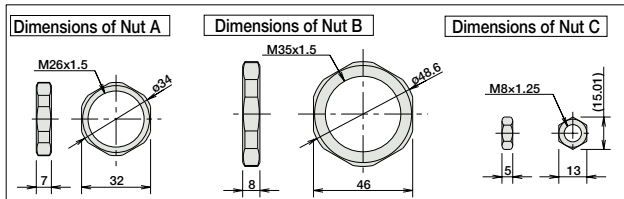
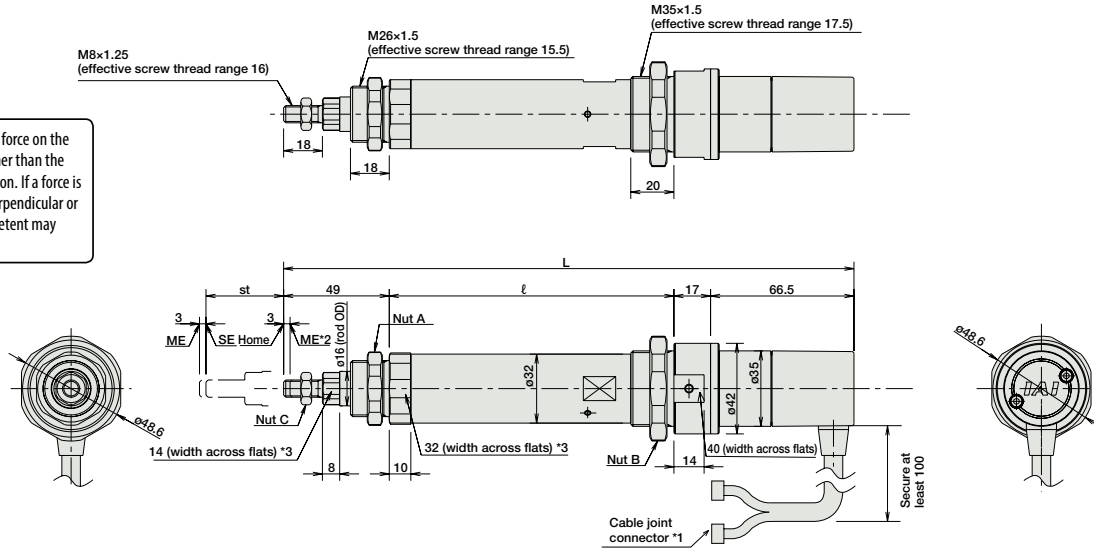

Dimensions and Weight by Stroke RCA-RA3D (without brake)

Stroke	50	100	150	200
L	264.5	314.5	364.5	414.5
ℓ	132	182	232	282
Weight (kg)	0.7	0.8	0.9	1.0

RCA-RA3D models are not equipped with a brake.

Applicable Controllers

RCA series actuators can be operated with the controllers indicated below. Select the type according to your intended application. \* ACON-CY also can be used.

Name	External view	Model number	Features	Maximum number of positioning points	Input power	Power-supply capacity	Standard price	Reference page
Solenoid Valve Type		AMEC-C-20SI①-②-2-1	Easy-to-use controller, even for beginners	3 points	AC100V	2.4A rated	—	→ P537
		ASEP-C-20SI①-②-2-0	Simple controller operable with the same signal as a solenoid valve					→ P547
Solenoid valve multi-axis type PIO specification		MSEP-C-③-④-2-0	Positioner type based on PIO control, allowing up to 8 axes to be connected	256 points	DC24V	(Standard) 1.7A rated 5.1A max.	—	→ P563
Solenoid valve multi-axis type Network specification		MSEP-C-③-④-0-0	Field network-ready positioner type, allowing up to 8 axes to be connected					
Positioner type		ACON-C-20SI①-②-2-0	Positioning is possible for up to 512 points	512 points	DC24V	(Power-saving) 1.7A rated 3.4A max.	—	→ P631
Safety-Compliant Positioner Type		ACON-CG-20SI①-②-2-0						
Pulse Train Input Type (Differential Line Driver)		ACON-PL-20SI①-②-2-0	Pulse train input type with differential line driver support	(—)	DC24V	(Power-saving) 1.7A rated 3.4A max.	—	→ P631
Pulse Train Input Type (Open Collector)		ACON-PO-20SI①-②-2-0	Pulse train input type with open collector support					
Serial Communication Type		ACON-SE-20SI①-N-0-0	Dedicated Serial Communication	64 points	DC24V	(Power-saving) 1.7A rated 3.4A max.	—	→ P631
Program Control Type		ASEL-CS-1-20SI①-②-2-0	Programmed operation is possible. Can operate up to 2 axes	1,500 points	DC24V	(Power-saving) 1.7A rated 3.4A max.	—	→ P675

\* This is for the single-axis ASEL. \* Enter the code "LA" in ① when the power-saving specification is specified. \* ③ indicates I/O type (NP/PN). \* ④ indicates number of axes (1 to 8). \* ⑤ indicates field network specification symbol.

- Slider Type
- Mini
- Standard
- Controller Integrated
- Rod Type
- Mini
- Standard
- Controllers Integrated
- Table/Arm/Flat Type
- Mini
- Standard
- Gripper/Rotary Type
- Linear Servo Type
- Clean-room Type
- Splash-Proof Type
- Pulse Motor
- Servo Motor (24V)
- Servo Motor (200V)
- Linear Servo Motor

# RCA-RA4D

Robo Cylinder, Rod Type, ø37mm Diameter, 24V Servo Motor, Built-In (Direct-Coupled) Motor

Model Specification Items	<b>RCA</b> — <b>RA4D</b> —	Encoder type	Motor type	Lead	Stroke	Applicable controller	Cable length	Options
	Series — Type	— Encoder type	— Motor type	— Lead	— Stroke	— Applicable controller	— Cable length	— Options
		I: Incremental A: Absolute *The absolute models are only compatible with ASEL. Simple absolute encoders are considered incremental.	20: 20W Servo motor 30: 30W Servo motor	12: 12mm 6: 6mm 3: 3mm	50: 50mm 300: 300mm (50mm pitch increments)	A1: ACON ASEL A3: AMEC ASEP MSEP	N: None P: 1m S: 3m M: 5m X□□: Custom Length R□□: Robot Cable	See Options below.

\* See page Pre-47 for details on the model descriptions.



Power-saving

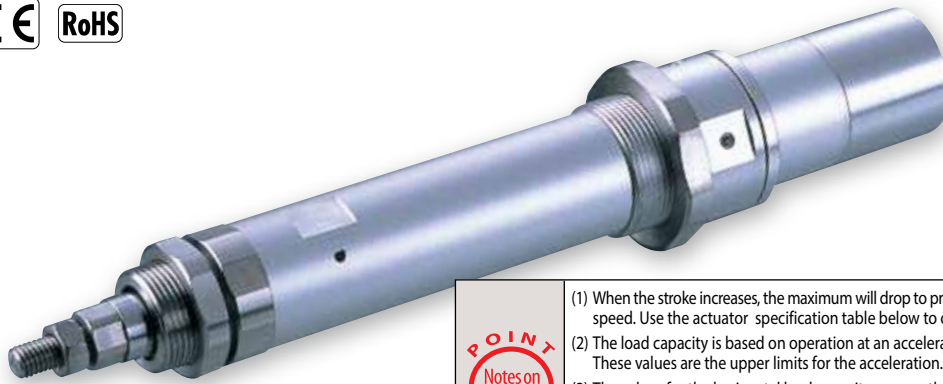

Technical References Appendix P.5



- (1) When the stroke increases, the maximum will drop to prevent the ball screw from reaching the critical rotational speed. Use the actuator specification table below to check the maximum speed at the stroke you desire.
- (2) The load capacity is based on operation at an acceleration of 0.3G (0.2G for 3mm-lead model). These values are the upper limits for the acceleration.
- (3) The values for the horizontal load capacity assume the use of an external guide, so that there is no external force from any direction other than the forward/backward direction of the rod.
- (4) Please note that there is no brake option for the motor built-in specification.
- (5) See page A-71 for details on push motion.

## Actuator Specifications

### Leads and Payloads

Model number	Motor output (W)	Lead (mm)	Max. Load Capacity		Rated thrust (N)	Stroke (mm)
			Horizontal (kg)	Vertical (kg)		
RCA-RA4D-①-20-12-②-③-④-⑤	20	12	3.0	1.0	18.9	50~300 (every 50mm)
RCA-RA4D-①-20-6-②-③-④-⑤		6	6.0	2.0	37.7	
RCA-RA4D-①-20-3-②-③-④-⑤		3	12.0	4.0	75.4	
RCA-RA4D-①-30-12-②-③-④-⑤	30	12	4.0	1.5	28.3	
RCA-RA4D-①-30-6-②-③-④-⑤		6	9.0	3.0	56.6	
RCA-RA4D-①-30-3-②-③-④-⑤		3	18.0	6.5	113.1	

### Stroke and Maximum Speed

Stroke / Lead	50~300 (every 50mm)
12	600
6	300
3	150

(Unit: mm/s)

Code explanation ① Encoder ② Stroke ③ Applicable controller ④ Cable length ⑤ Options \*See page A-71 for details on push motion.

### ① Encoder Type/② Stroke

② Stroke (mm)	Standard price			
	① Encoder Type			
	Incremental		Absolute	
	Motor Output (W)	Motor Output (W)	Motor Output (W)	Motor Output (W)
	20W	30W	20W	30W
50	—	—	—	—
100	—	—	—	—
150	—	—	—	—
200	—	—	—	—
250	—	—	—	—
300	—	—	—	—

### ④ Cable Length

Type	Cable symbol	Standard Price
Standard	P (1m)	—
	S (3m)	—
	M (5m)	—
Special length	X06 (6m) ~ X10 (10m)	—
	X11 (11m) ~ X15 (15m)	—
	X16 (16m) ~ X20 (20m)	—
Robot Cable	R01 (1m) ~ R03 (3m)	—
	R04 (4m) ~ R05 (5m)	—
	R06 (6m) ~ R10 (10m)	—
	R11 (11m) ~ R15 (15m)	—
	R16 (16m) ~ R20 (20m)	—

\* See page A-59 for cables for maintenance.

### ⑤ Options

Name	Option code	See page	Standard price
Foot bracket	FT	→ A-49	—
Flange bracket (front)	FL	→ A-45	—
Flange bracket (back)	FLR	→ A-46	—
Home sensor	HS	→ A-50	—
Power-saving	LA	→ A-52	—
Knuckle joint	NJ	→ A-53	—
Non-motor end specification	NM	→ A-52	—
Trunnion bracket (front)	TRF	→ A-57	—
Trunnion bracket (back)	TRR	→ A-58	—

\*The home sensor (HS) cannot be used on the Non-motor end models.

### Actuator Specifications

Item	Description
Drive System	Ball screw, ø10mm, rolled C10
Positioning Repeatability	±0.02mm
Lost Motion	0.1mm or less
Base	Material: Aluminum, white alumite treated
Rod diameter	ø20mm
Non-rotating accuracy of rod	±1.0 deg
Ambient operating temperature, humidity	0 to 40°C, 85% RH or less (Non-condensing)

Dimensional Drawings

CAD drawings can be downloaded from the website. [www.intelligentactuator.com](http://www.intelligentactuator.com)

For Special Orders Appendix P.15

2D CAD [No Brake]

Note:  
Do not apply any external force on the rod from any direction other than the direction of the rod's motion. If a force is exerted on the rod in a perpendicular or rotational direction, the detent may become damaged.

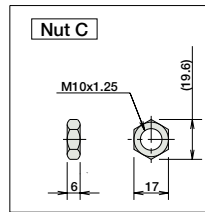
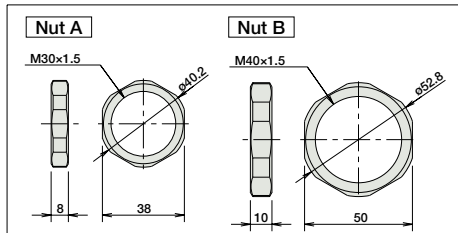
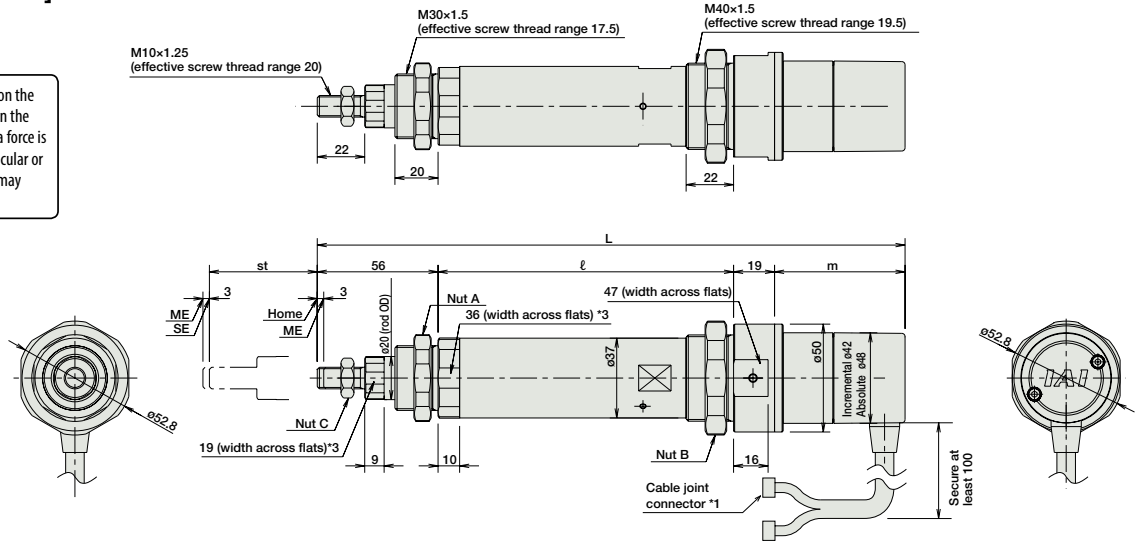

Dimensions and Weight by Stroke RCA-RA4D (without brake)

Stroke	RCA-RA4D (without brake)						
	50	100	150	200	250	300	
L	20W	Incr. 257.5	307.5	357.5	407.5	457.5	507.5
		Absol. 270.5	320.5	370.5	420.5	470.5	520.5
30W	Incr.	272.5	322.5	372.5	422.5	472.5	522.5
	Absol.	285.5	335.5	385.5	435.5	485.5	535.5
ℓ		137	187	237	287	337	387
m	20W	Incr. 45.5				Absol. 58.5	
	30W	Incr. 60.5				Absol. 73.5	
Weight (kg)		1.0	1.2	1.3	1.5	1.6	1.8

- (\*1) Connect the motor and encoder cables here. See page A-59 for details on cables.
- (\*2) After homing, the slider moves to the ME, therefore, please watch for any interference with surrounding objects.  
ME: Mechanical end SE: Stroke end
- (\*3) The orientation of the bolt varies depending on the product.

RCA-RA4D models are not equipped with a brake.

Applicable Controllers

RCA series actuators can be operated with the controllers indicated below. Select the type according to your intended application. \* ACON-CY also can be used.

Name	External view	Model number	Features	Maximum number of positioning points	Input power	Power-supply capacity	Standard price	Reference page
Solenoid Valve Type		AMEC-C-20I(①)-②-1 AMEC-C-30I(①)-②-1	Easy-to-use controller, even for beginners	3 points	AC100V	2.4A rated	—	→ P537
		ASEP-C-20I(①)-②-0 ASEP-C-30I(①)-②-0	Simple controller operable with the same signal as a solenoid valve					
Solenoid valve multi-axis type PIO specification		MSEP-C-④-④-②-0	Positioner type based on PIO control, allowing up to 8 axes to be connected	256 points	DC24V	(Standard) 20W 1.3A rated 4.4A max. 30W 1.3A rated 4.4A max.	—	→ P563
Solenoid valve multi-axis type Network specification		MSEP-C-④-④-⑤-0-0	Field network-ready positioner type, allowing up to 8 axes to be connected					
Positioner type		ACON-C-20I(①)-②-0 ACON-C-30I(①)-②-0	Positioning is possible for up to 512 points	512 points	DC24V	(Power-saving) 20W 1.3A rated 2.5A max. 30W 1.3A rated 2.2A max.	—	→ P631
Safety-Compliant Positioner Type		ACON-CG-20I(①)-②-0 ACON-CG-30I(①)-②-0						
Pulse Train Input Type (Differential Line Driver)		ACON-PL-20I(①)-②-0 ACON-PL-30I(①)-②-0	Pulse train input type with differential line driver support	(—)	DC24V	(Power-saving) 20W 1.3A rated 2.5A max. 30W 1.3A rated 2.2A max.	—	→ P631
Pulse Train Input Type (Open Collector)		ACON-PO-20I(①)-②-0 ACON-PO-30I(①)-②-0	Pulse train input type with open collector support					
Serial Communication Type		ACON-SE-20I(①)-N-0-0 ACON-SE-30I(①)-N-0-0	Dedicated Serial Communication	64 points	DC24V	(Power-saving) 20W 1.3A rated 2.5A max. 30W 1.3A rated 2.2A max.	—	→ P675
Program Control Type		ASEL-CS-1-20I(①)-②-0 ASEL-CS-1-30I(①)-②-0	Programmed operation is possible. Can operate up to 2 axes	1,500 points	DC24V	(Power-saving) 20W 1.3A rated 2.5A max. 30W 1.3A rated 2.2A max.	—	→ P675

\* This is for the single-axis ASEL. \* ① indicates encoder type (I: incremental, A: absolute) \* Enter the code "LA" in ① when the power-saving specification is specified.  
 \* ② indicates I/O type (NP/PN). \* ④ indicates number of axes (1 to 8). \* ⑤ indicates field network specification symbol.

# RCA-RA3R

Robo Cylinder, Rod Type, ø32mm Diameter, 24V Servo Motor, Side-Mounted Motor

Model Specification Items	<b>RCA</b> — <b>RA3R</b> — <b>I</b> — <b>20</b> — <input type="checkbox"/> — <input type="checkbox"/> — <input type="checkbox"/> — <input type="checkbox"/> — <input type="checkbox"/>	Series — Type — Encoder type — Motor type — Lead — Stroke — Applicable controller — Cable length — Options
	I: Incremental * The Simple absolute encoder is also considered type "I".	20: 20W Servo motor 10: 10mm 5: 5mm 2.5: 2.5mm 50: 50mm { 200: 200mm (50mm pitch increments)

A1: ACON  
ASEL  
A3: AMEC  
ASEP  
MSEP

N: None  
P: 1m  
S: 3m  
M: 5m  
X: Custom Length  
R: Robot Cable

See Options below.

\* See page Pre-47 for details on the model descriptions.



Power-saving



Technical References Appendix P.5

- POINT**  
Notes on selection
- When the stroke increases, the maximum will drop to prevent the ball screw from reaching the critical rotational speed. Use the actuator specification table below to check the maximum speed at the stroke you desire.
  - The load capacity is based on operation at an acceleration of 0.3G (0.2G for 2.5mm-lead model). These values are the upper limits for the acceleration.
  - The values for the horizontal load capacity assume the use of an external guide, so that there is no external force from any direction other than the forward/backward direction of the rod.
  - See page A-71 for details on push motion.

### Actuator Specifications

#### Leads and Payloads

Model number	Motor output (W)	Lead (mm)	Max. Load Capacity		Rated thrust (N)	Stroke (mm)
			Horizontal (kg)	Vertical (kg)		
RCA-RA3R-I-20-10-①-②-③-④	20	10	4.0	1.5	36.2	50~200 (every 50mm)
RCA-RA3R-I-20-5-①-②-③-④		5	9.0	3.0	72.4	
RCA-RA3R-I-20-2.5-①-②-③-④		2.5	18.0	6.5	144.8	

#### Stroke and Maximum Speed

Lead	Stroke	50~200 (every 50mm)
	10	
5		250
2.5		125

Code explanation ① Stroke ② Applicable controller ③ Cable length ④ Options \*See page A-71 for details on push motion. (Unit: mm/s)

#### ① Stroke

① Stroke (mm)	Standard price
50	—
100	—
150	—
200	—

#### ④ Options

Name	Option code	See page	Standard price
Brake	<b>B</b>	→ A-42	—
Foot bracket	<b>FT</b>	→ A-49	—
Flange bracket (front)	<b>FL</b>	→ A-45	—
Flange bracket (back)	<b>FLR</b>	→ A-46	—
Home sensor	<b>HS</b>	→ A-50	—
Power-saving	<b>LA</b>	→ A-52	—
Knuckle joint	<b>NJ</b>	→ A-53	—
Non-motor end specification	<b>NM</b>	→ A-52	—
Clevis bracket	<b>QR</b>	→ A-53	—
Back-mounting plate	<b>RP</b>	→ A-54	—
Trunnion bracket (front)	<b>TRF</b>	→ A-57	—

\*The home sensor (HS) cannot be used on the Non-motor end models.

#### ③ Cable Length

Type	Cable symbol	Standard Price
Standard	<b>P</b> (1m)	—
	<b>S</b> (3m)	—
	<b>M</b> (5m)	—
Special length	<b>X06</b> (6m) ~ <b>X10</b> (10m)	—
	<b>X11</b> (11m) ~ <b>X15</b> (15m)	—
	<b>X16</b> (16m) ~ <b>X20</b> (20m)	—
Robot Cable	<b>R01</b> (1m) ~ <b>R03</b> (3m)	—
	<b>R04</b> (4m) ~ <b>R05</b> (5m)	—
	<b>R06</b> (6m) ~ <b>R10</b> (10m)	—
	<b>R11</b> (11m) ~ <b>R15</b> (15m)	—
	<b>R16</b> (16m) ~ <b>R20</b> (20m)	—

\* See page A-59 for cables for maintenance.

#### Actuator Specifications

Item	Description
Drive System	Ball screw, ø8mm, rolled C10
Positioning Repeatability	±0.02mm
Lost Motion	0.1mm or less
Base	Material: Aluminum, white alumite treated
Rod diameter	ø16mm
Non-rotating accuracy of rod	±1.0 deg
Ambient operating temperature, humidity	0 to 40°C, 85% RH or less (Non-condensing)

Dimensional Drawings

CAD drawings can be downloaded from the website.

www.intelligentactuator.com

For Special Orders

Appendix P.15



- (\*1) Connect the motor and encoder cables here. See page A-59 for details on cables.
- (\*2) After homing, the slider moves to the ME, therefore, please watch for any interference with surrounding objects.  
ME : Mechanical end SE : Stroke end
- (\*3) The orientation of the bolt varies depending on the product.

[No Brake]

Note:

Do not apply any external force on the rod from any direction other than the direction of the rod's motion. If a force is exerted on the rod in a perpendicular or rotational direction, the detent may become damaged.

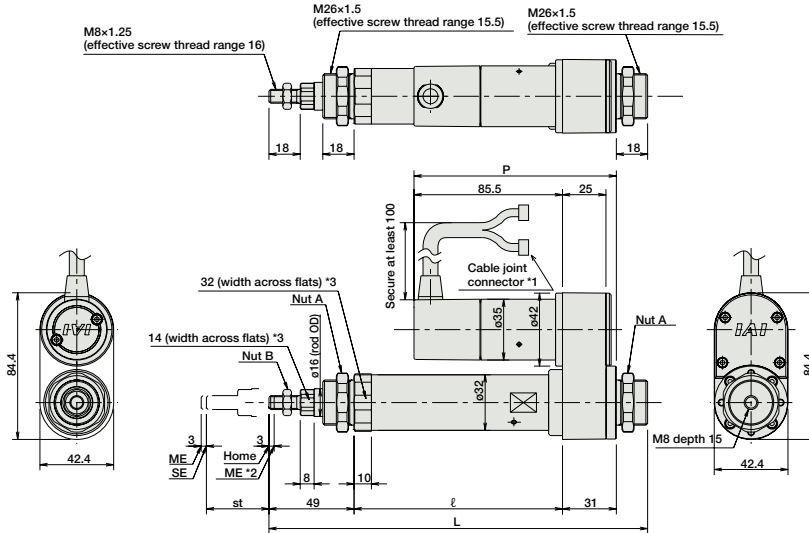

[Brake-Equipped]

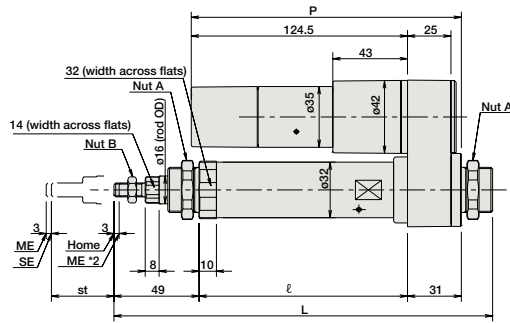
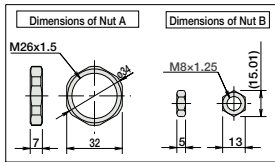

Dimensions and Weight by Stroke  
RCA-RA3R (without brake)

Stroke	50	100	150	200
L	218	268	318	368
ℓ	120	170	220	270
P	116.5			
Weight (kg)	0.8	0.9	1.0	1.1

RCA-RA3R (with brake)

Stroke	50	100	150	200
L	218	268	318	368
ℓ	120	170	220	270
P	155.5			
Weight (kg)	1.0	1.1	1.2	1.3

Applicable Controllers

RCA series actuators can be operated with the controllers indicated below. Select the type according to your intended application. \* ACON-CY also can be used.

Name	External view	Model number	Features	Maximum number of positioning points	Input power	Power-supply capacity	Standard price	Reference page
Solenoid Valve Type		AMEC-C-20SI①-②-2-1	Easy-to-use controller, even for beginners	3 points	AC100V	2.4A rated	—	→ P537
		ASEP-C-20SI①-②-2-0	Simple controller operable with the same signal as a solenoid valve					→ P547
Solenoid valve multi-axis type PIO specification		MSEP-C-③-④-2-0	Positioner type based on PIO control, allowing up to 8 axes to be connected	256 points	DC24V	(Standard) 1.7A rated 5.1A max.	—	→ P563
Solenoid valve multi-axis type Network specification		MSEP-C-③-④-0-0	Field network-ready positioner type, allowing up to 8 axes to be connected					
Positioner type		ACON-C-20SI①-②-2-0	Positioning is possible for up to 512 points	512 points	DC24V	(Power-saving) 1.7A rated 3.4A max.	—	→ P631
Safety-Compliant Positioner Type		ACON-CG-20SI①-②-2-0						
Pulse Train Input Type (Differential Line Driver)		ACON-PL-20SI①-②-2-0	Pulse train input type with differential line driver support	(—)	DC24V	(Power-saving) 1.7A rated 3.4A max.	—	→ P631
Pulse Train Input Type (Open Collector)		ACON-PO-20SI①-②-2-0	Pulse train input type with open collector support					
Serial Communication Type		ACON-SE-20SI①-N-0-0	Dedicated Serial Communication	64 points	DC24V	(Power-saving) 1.7A rated 3.4A max.	—	→ P631
Program Control Type		ASEL-CS-1-20SI①-②-2-0	Programmed operation is possible. Can operate up to 2 axes	1,500 points	DC24V	(Power-saving) 1.7A rated 3.4A max.	—	→ P675

\* This is for the single-axis ASEL. \* Enter the code "LA" in ① when the power-saving specification is specified. \* ③ indicates I/O type (NP/PN). \* ④ indicates number of axes (1 to 8). \* ⑤ indicates field network specification symbol.

# RCA-RA4R

Robo Cylinder, Rod Type, ø37mm Diameter, 24V Servo Motor, Side-Mounted Motor

Model Specification Items	<b>RCA</b> — <b>RA4R</b> —	—	—	—	—	—	—	—	—	—
	Series	Type	Encoder type	Motor type	Lead	Stroke	Applicable controller	Cable length	Options	
	I: Incremental A: Absolute	20: 20W Servo motor 30: 30W Servo motor		12: 12mm 6: 6mm 3: 3mm	50: 50mm 300: 300mm (50mm pitch increments)	A1: ACON ASEL A3: AMEC ASEP MSEP	N: None P: 1m S: 3m M: 5m X□□: Custom Length R□□: Robot Cable	See Options below.		

\* See page Pre-47 for details on the model descriptions.  
\* The absolute models are only compatible with ASEL. Simple absolute encoders are considered incremental.



Power-saving

Technical References Appendix P.5

- POINT**  
Notes on selection
- (1) When the stroke increases, the maximum will drop to prevent the ball screw from reaching the critical rotational speed. Use the actuator specification table below to check the maximum speed at the stroke you desire.
  - (2) The load capacity is based on operation at an acceleration of 0.3G (0.2G for 3mm-lead model). These values are the upper limits for the acceleration.
  - (3) The values for the horizontal load capacity assume the use of an external guide, so that there is no external force from any direction other than the forward/backward direction of the rod.
  - (4) See page A-71 for details on push motion.

### Actuator Specifications

#### Leads and Payloads

Model number	Motor output (W)	Lead (mm)	Max. Load Capacity		Rated thrust (N)	Stroke (mm)
			Horizontal (kg)	Vertical (kg)		
RCA-RA4R-①-20-12-②-③-④-⑤	20	12	3.0	1.0	18.9	50~300 (every 50mm)
RCA-RA4R-①-20-6-②-③-④-⑤		6	6.0	2.0	37.7	
RCA-RA4R-①-20-3-②-③-④-⑤		3	12.0	4.0	75.4	
RCA-RA4R-①-30-12-②-③-④-⑤	30	12	4.0	1.5	28.3	
RCA-RA4R-①-30-6-②-③-④-⑤		6	9.0	3.0	56.6	
RCA-RA4R-①-30-3-②-③-④-⑤		3	18.0	6.5	113.1	

#### Stroke and Maximum Speed

Lead	Stroke	50~300 (every 50mm)
	12	
6		300
3		150

(Unit: mm/s)

Code explanation ① Encoder ② Stroke ③ Applicable controller ④ Cable length ⑤ Options \*See page A-71 for details on push motion.

#### ① Encoder Type/② Stroke

② Stroke (mm)	Standard price			
	① Encoder Type			
	Incremental		Absolute	
	Motor Output (W)		Motor Output (W)	
	20W	30W	20W	30W
50	—	—	—	—
100	—	—	—	—
150	—	—	—	—
200	—	—	—	—
250	—	—	—	—
300	—	—	—	—

#### ⑤ Options

Name	Option code	See page	Standard price
Brake	<b>B</b>	→ A-42	—
Foot bracket	<b>FT</b>	→ A-49	—
Flange bracket (front)	<b>FL</b>	→ A-45	—
Flange bracket (back)	<b>FLR</b>	→ A-46	—
Home sensor	<b>HS</b>	→ A-50	—
Power-saving	<b>LA</b>	→ A-52	—
Knuckle joint	<b>NJ</b>	→ A-53	—
Non-motor end specification	<b>NM</b>	→ A-52	—
Clevis bracket	<b>QR</b>	→ A-53	—
Back-mounting plate	<b>RP</b>	→ A-54	—
Trunnion bracket (front)	<b>TRF</b>	→ A-57	—

\*The home sensor (HS) cannot be used on the Non-motor end models.

#### ④ Cable Length

Type	Cable symbol	Standard Price
Standard	<b>P</b> (1m)	—
	<b>S</b> (3m)	—
	<b>M</b> (5m)	—
Special length	<b>X06</b> (6m) ~ <b>X10</b> (10m)	—
	<b>X11</b> (11m) ~ <b>X15</b> (15m)	—
	<b>X16</b> (16m) ~ <b>X20</b> (20m)	—
Robot Cable	<b>R01</b> (1m) ~ <b>R03</b> (3m)	—
	<b>R04</b> (4m) ~ <b>R05</b> (5m)	—
	<b>R06</b> (6m) ~ <b>R10</b> (10m)	—
	<b>R11</b> (11m) ~ <b>R15</b> (15m)	—
	<b>R16</b> (16m) ~ <b>R20</b> (20m)	—

\* See page A-59 for cables for maintenance.

### Actuator Specifications

Item	Description
Drive System	Ball screw, ø10mm, rolled C10
Positioning Repeatability	±0.02mm
Lost Motion	0.1mm or less
Base	Material: Aluminum, white alumite treated
Rod diameter	ø20mm
Non-rotating accuracy of rod	±1.0 deg
Ambient operating temperature, humidity	0 to 40°C, 85% RH or less (Non-condensing)

Dimensional Drawings

CAD drawings can be downloaded from the website.

www.intelligentactuator.com



- (\*1) Connect the motor and encoder cables here. See page A-59 for details on cables.
- (\*2) After homing, the slider moves to the ME, therefore, please watch for any interference with surrounding objects.  
ME: Mechanical end SE: Stroke end
- (\*3) The orientation of the bolt varies depending on the product.

For Special Orders

Appendix P.15

[No Brake]

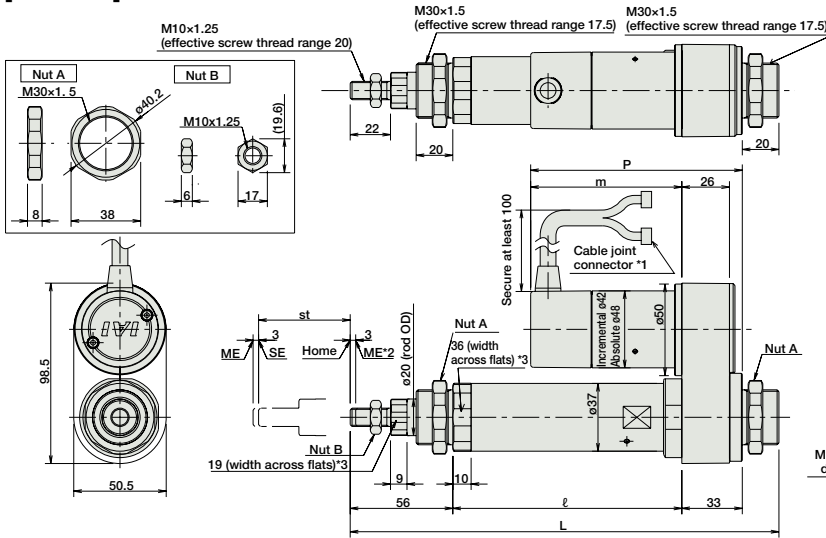

Dimensions and Weight by Stroke  
RCA-RA4R (without brake)

Stroke		50	100	150	200	250	300
L	20W	Increm. 234	284	334	384	434	484
		Absol. 234	284	334	384	434	484
L	30W	Increm. 234	284	334	384	434	484
		Absol. 234	284	334	384	434	484
ℓ		125	175	225	275	325	375
m	20W	Increm. 67.5					
		Absol. 80.5					
m	30W	Increm. 82.5					
		Absol. 95.5					
P	20W	Increm. 100.5					
		Absol. 113.5					
P	30W	Increm. 115.5					
		Absol. 128.5					
Weight (kg)		1.2	1.4	1.5	1.7	1.8	2.0

Note:  
Do not apply any external force on the rod from any direction other than the direction of the rod's motion. If a force is exerted on the rod in a perpendicular or rotational direction, the detent may become damaged.

[Brake-Equipped]

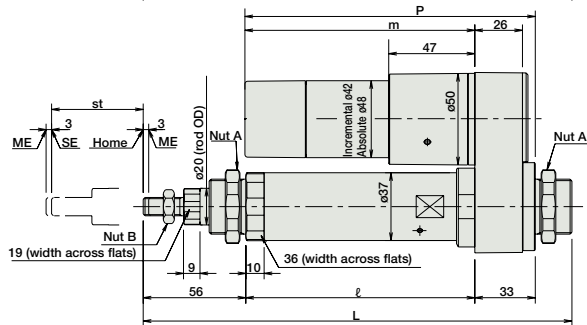

RCA-RA4R (with brake)

Stroke		50	100	150	200	250	300
L	20W	Increm. 234	284	334	384	434	484
		Absol. 234	284	334	384	434	484
L	30W	Increm. 234	284	334	384	434	484
		Absol. 234	284	334	384	434	484
ℓ		125	175	225	275	325	375
m	20W	Increm. 110.5					
		Absol. 123.5					
m	30W	Increm. 125.5					
		Absol. 138.5					
P	20W	Increm. 143.5					
		Absol. 156.5					
P	30W	Increm. 158.5					
		Absol. 171.5					
Weight (kg)		1.4	1.6	1.7	1.9	2.0	2.2

Applicable Controllers

RCA series actuators can be operated with the controllers indicated below. Select the type according to your intended application. \* ACON-CY also can be used.

Name	External view	Model number	Features	Maximum number of positioning points	Input power	Power-supply capacity	Standard price	Reference page
Solenoid Valve Type		AMEC-C-20I(Ⓜ)-2-1 AMEC-C-30I(Ⓜ)-2-1	Easy-to-use controller, even for beginners	3 points	AC100V	2.4A rated	—	→ P537
		ASEP-C-20I(Ⓜ)-2-0 ASEP-C-30I(Ⓜ)-2-0	Simple controller operable with the same signal as a solenoid valve					→ P547
Solenoid valve multi-axis type PIO specification		MSEP-C-IV~2-0	Positioner type based on PIO control, allowing up to 8 axes to be connected	256 points	DC24V	(Standard) 20W 1.3A rated 4.4A max. 30W 1.3A rated 4.4A max.	—	→ P563
Solenoid valve multi-axis type Network specification		MSEP-C-IV~V-0-0	Field network-ready positioner type, allowing up to 8 axes to be connected					
Positioner type		ACON-C-20I(Ⓜ)-2-0 ACON-C-30I(Ⓜ)-2-0	Positioning is possible for up to 512 points	512 points	DC24V	(Power-saving) 20W 1.3A rated 2.5A max. 30W 1.3A rated 2.2A max.	—	→ P631
Safety-Compliant Positioner Type		ACON-CG-20I(Ⓜ)-2-0 ACON-CG-30I(Ⓜ)-2-0						
Pulse Train Input Type (Differential Line Driver)		ACON-PL-20I(Ⓜ)-2-0 ACON-PL-30I(Ⓜ)-2-0	Pulse train input type with differential line driver support	(—)	DC24V	(Power-saving) 20W 1.3A rated 2.5A max. 30W 1.3A rated 2.2A max.	—	→ P631
Pulse Train Input Type (Open Collector)		ACON-PO-20I(Ⓜ)-2-0 ACON-PO-30I(Ⓜ)-2-0	Pulse train input type with open collector support					
Serial Communication Type		ACON-SE-20I(Ⓜ)-N-0-0 ACON-SE-30I(Ⓜ)-N-0-0	Dedicated Serial Communication	64 points	DC24V	(Power-saving) 20W 1.3A rated 2.5A max. 30W 1.3A rated 2.2A max.	—	→ P675
Program Control Type		ASEL-CS-1-20I(Ⓜ)-2-0 ASEL-CS-1-30I(Ⓜ)-2-0	Programmed operation is possible. Can operate up to 2 axes	1,500 points	DC24V	(Power-saving) 20W 1.3A rated 2.5A max. 30W 1.3A rated 2.2A max.	—	→ P675

\* This is for the single-axis ASEL. \* Ⓜ indicates encoder type (I: incremental, A: absolute) \* Enter the code "LA" in Ⓜ when the power-saving specification is specified.  
 \* Ⓜ indicates I/O type (NP/PN). \* IV indicates number of axes (1 to 8). \* V indicates field network specification symbol.

- Slider Type
- Mini
- Standard
- Controller Integrated
- Rod Type
- Mini
- Standard
- Controllers Integrated
- Table/Arm/Flat Type
- Mini
- Standard
- Gripper/Rotary Type
- Linear Servo Type
- Clean-room Type
- Splash-Proof Type
- Pulse Motor
- Servo Motor (24V)
- Servo Motor (200V)
- Linear Servo Motor



# RCA-SRA4R

Robo Cylinder, Rod Type, Actuator Width 45mm, Servo Motor, Short-Length Type

Model Specification Items	<b>RCA</b>	<b>SRA4R</b>	<b>I</b>	<b>20</b>	<input type="checkbox"/>	<input type="checkbox"/>	<input type="checkbox"/>	<input type="checkbox"/>	<input type="checkbox"/>
	Series	Type	Encoder type	Motor type	Lead	Stroke	Applicable controller	Cable length	Options
			I: Incremental * The Simple absolute encoder is also considered type "I".	20: 20W Servo motor	5: 5mm 2.5: 2.5mm	20: 20mm { 200: 200mm (10mm pitch increments) * Set in 50mm increments over 100mm	A1: ACON ASEL A3: AMEC ASEP MSEP	N: None P: 1m S: 3m M: 5m X□□: Custom Length	See Options below.

\* See page Pre-47 for details on the model descriptions.



Power-saving



Technical References Appendix P.5

- POINT** Notes on selection
- (1) The load capacity is based on operation at an acceleration of 0.3G (0.2G for the 2.5mm-lead model, or when used vertically). This is the upper limit of the acceleration.
  - (2) The horizontal load capacity is based on the use of an external guide. If an external force is exerted on the rod from a direction other than the motion of the rod, the detent may become damaged.
  - (3) See page A-71 for details on push motion.

### Actuator Specifications

#### Leads and Payloads

(Note A) 50mm increments over 100mm.

Model number	Motor output (W)	Lead (mm)	Max. Load Capacity		Rated thrust (N)	Stroke (mm)
			Horizontal (kg)	Vertical (kg)		
RCA-SRA4R-I-20-5-①-②-③-④	20	5	9 (Note1)	3	41	20~200 (every 10mm) (Note A)
RCA-SRA4R-I-20-2.5-①-②-③-④		2.5	18 (Note1)	6.5	81	

#### Stroke and Maximum Speed

Lead	Stroke	20~200 (every 10mm)
	5	
2.5		125

Code explanation ① Stroke ② Applicable controller ③ Cable length ④ Options \*See page A-71 for details on push motion. (Unit: mm/s)

#### ① Stroke

① Stroke (mm)	Standard price
20~50	—
60~100	—
150	—
200	—

#### ③ Cable Length

Type	Cable symbol	Standard Price
Standard (Robot Cables)	P (1m)	—
	S (3m)	—
	M (5m)	—
Special length	X06 (6m) ~ X10 (10m)	—
	X11 (11m) ~ X15 (15m)	—
	X16 (16m) ~ X20 (20m)	—

\* The cable is a motor-encoder integrated cable, and is provided as a robot cable. \* See page A-59 for cables for maintenance.

#### ④ Options

Name	Option code	See page	Standard price
Brake	B	→ A-42	—
Flange bracket (front)	FL	→ A-44	—
Flange bracket (back)	FLR	→ A-46	—
Foot bracket 1 (base mounting)	FT	→ A-48	—
Foot bracket 2 (right/left side mounting)	FT2/FT4	→ A-50	—
Power-saving	LA	→ A-52	—
Non-motor end specification	NM	→ A-52	—

\* The brake is available for strokes of 70mm or more.

#### Actuator Specifications

Item	Description
Drive System	Ball screw, ø8mm, rolled C10
Positioning Repeatability	±0.02mm
Lost Motion	0.1mm or less
Rod diameter	ø22mm
Non-rotating accuracy of rod	—
Ambient operating temperature, humidity	0 to 40°C, 85% RH or less (Non-condensing)

Dimensional Drawings

CAD drawings can be downloaded from the website. [www.intelligentactuator.com](http://www.intelligentactuator.com)

For Special Orders Appendix P.15

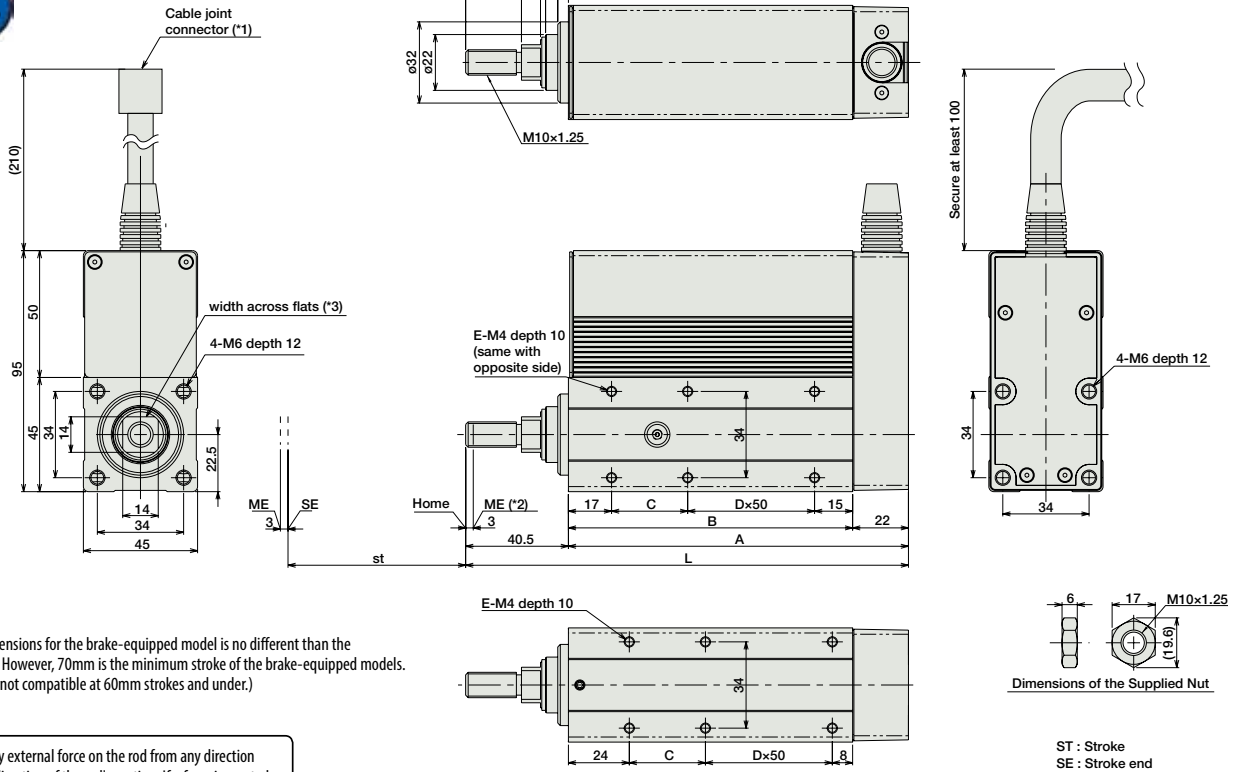

\*The exterior dimensions for the brake-equipped model is no different than the standard model. However, 70mm is the minimum stroke of the brake-equipped models. (i.e. The brake is not compatible at 60mm strokes and under.)

Note:  
Do not apply any external force on the rod from any direction other than the direction of the rod's motion. If a force is exerted on the rod in a perpendicular or rotational direction, the detent may become damaged.

- (\*1) Connect the motor-encoder integrated cable here. See page A-59 for details on cables.
- (\*2) After homing, the slider moves to the ME, therefore, please watch for any interference with surrounding objects.
- (\*3) The orientation of the bolt varies depending on the product.

Dimensions and Weight by Stroke

Stroke	20	30	40	50	60	70	80	90	100	150	200
L	124.5	134.5	144.5	154.5	164.5	174.5	184.5	194.5	204.5	254.5	304.5
A	84	94	104	114	124	134	144	154	164	214	264
B	62	72	82	92	102	112	122	132	142	192	242
C	30	40	50	60	70	30	40	50	60	60	60
D	0	0	0	0	0	1	1	1	1	2	3
E	4	4	4	4	4	6	6	6	6	8	10
Weight (kg)	0.78	0.84	0.9	0.96	1.03	1.09	1.15	1.21	1.27	1.59	1.9

(Add 0.2kg for brake equipped)

Applicable Controllers

RCA series actuators can be operated with the controllers indicated below. Select the type according to your intended application. \* ACON-CY also can be used.

Name	External view	Model number	Features	Maximum number of positioning points	Input power	Power-supply capacity	Standard price	Reference page
Solenoid Valve Type		AMEC-C-20I-①-②-2-1	Easy-to-use controller, even for beginners	3 points	AC100V	2.4A rated	—	→ P537
		ASEP-C-20I-①-②-2-0	Simple controller operable with the same signal as a solenoid valve					→ P547
Solenoid valve multi-axis type PIO specification		MSEP-C-③-④-⑤-2-0	Positioner type based on PIO control, allowing up to 8 axes to be connected	256 points	DC24V	(Standard) 1.3A rated 4.4A max.	—	→ P563
Solenoid valve multi-axis type Network specification		MSEP-C-③-④-⑤-0-0	Field network-ready positioner type, allowing up to 8 axes to be connected					
Positioner type		ACON-C-20I-①-②-2-0	Positioning is possible for up to 512 points	512 points	DC24V	(Power-saving) 1.3A rated 2.5A max.	—	→ P631
Safety-Compliant Positioner Type		ACON-CG-20I-①-②-2-0						
Pulse Train Input Type (Differential Line Driver)		ACON-PL-20I-①-②-2-0	Pulse train input type with differential line driver support	(—)	DC24V	(Power-saving) 1.3A rated 2.5A max.	—	→ P631
Pulse Train Input Type (Open Collector)		ACON-PO-20I-①-②-2-0	Pulse train input type with open collector support					
Serial Communication Type		ACON-SE-20I-①-N-0-0	Dedicated Serial Communication	64 points	DC24V	(Power-saving) 1.3A rated 2.5A max.	—	→ P675
Program Control Type		ASEL-CS-1-20I-①-②-2-0	Programmed operation is possible. Can operate up to 2 axes	1,500 points	DC24V	(Power-saving) 1.3A rated 2.5A max.	—	→ P675

\* This is for the single-axis ASEL. \* Enter the code "LA" in ① when the power-saving specification is specified. \* ③ indicates I/O type (NP/PN). \* ④ indicates number of axes (1 to 8). \* ⑤ indicates field network specification symbol.



RCA-SRA4R **234** ELECTROMATE  
 Toll Free Phone (877) SERV098  
 Toll Free Fax (877) SERV099  
[www.electromate.com](http://www.electromate.com)  
[sales@electromate.com](mailto:sales@electromate.com)

- Slider Type
- Mini
- Standard
- Controller Integrated
- Rod Type
- Mini
- Standard
- Controllers Integrated
- Table/Arm/Flat Type
- Mini
- Standard
- Gripper/Rotary Type
- Linear Servo Type
- Clean-room Type
- Splash-Proof Type
- Pulse Motor
- Servo Motor (24V)
- Servo Motor (200V)
- Linear Servo Motor

# RCA-RGS3C

Robo Cylinder, Rod Type with Single Guide, ø32mm Diameter, 24V Servo Motor, Coupled

Model Specification Items	<b>RCA</b> — <b>RGS3C</b> — <b>I</b> — <b>20</b> — <input type="checkbox"/> — <input type="checkbox"/> — <input type="checkbox"/> — <input type="checkbox"/> — <input type="checkbox"/>
	Series — Type — Encoder type — Motor type — Lead — Stroke — Applicable controller — Cable length — Options
	I: Incremental * The Simple absolute encoder is also considered type "I".
	20: 20W Servo motor
	10 : 10mm 5 : 5mm 2.5: 2.5mm
	50: 50mm { 200: 200mm (50mm pitch increments)
	A1: ACON ASEL A3: AMEC ASEP MSEP
	N: None P: 1m S: 3m M: 5m X <input type="checkbox"/> : Custom Length R <input type="checkbox"/> : Robot Cable
	See Options below.

\* See page Pre-47 for details on the model descriptions.



**For High Acceleration/Deceleration**

**Power-saving**

(excluding the 2.5mm-lead model)

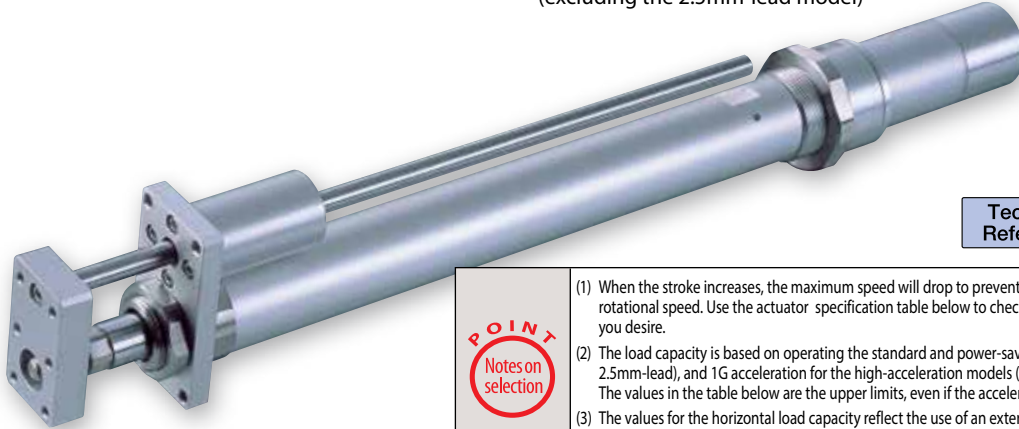

Technical References Appendix P.5



- When the stroke increases, the maximum speed will drop to prevent the ball screw from reaching the critical rotational speed. Use the actuator specification table below to check the maximum speed at the stroke you desire.
- The load capacity is based on operating the standard and power-saving models at 0.3G (0.2G for 2.5mm-lead), and 1G acceleration for the high-acceleration models (2.5mm-lead model excluded). The values in the table below are the upper limits, even if the acceleration/deceleration is decreased.
- The values for the horizontal load capacity reflect the use of an external guide. See the technical resources (page A-110) for the allowable weight using the supplied guide alone.
- See page A-71 for details on push motion.

### Actuator Specifications

#### Leads and Payloads

Model number	Motor output (W)	Lead (mm)	Max. Load Capacity		Rated thrust (N)	Stroke (mm)
			Horizontal (kg)	Vertical (kg)		
RCA-RGS3C-I-20-10-①-②-③-④	20	10	4.0	1.2	36.2	50~200 (every 50mm)
RCA-RGS3C-I-20-5-①-②-③-④		5	9.0	2.7	72.4	
RCA-RGS3C-I-20-2.5-①-②-③-④		2.5	18.0	6.2	144.8	

#### Stroke and Maximum Speed

Stroke / Lead	50~200 (every 50mm)
	10
5	250
2.5	125

Code explanation ① Stroke ② Applicable controller ③ Cable length ④ Options \*See page A-71 for details on push motion. (Unit: mm/s)

#### ① Stroke

① Stroke (mm)	Standard price
50	—
100	—
150	—
200	—

#### ③ Cable Length

Type	Cable symbol	Standard Price
Standard	P (1m)	—
	S (3m)	—
	M (5m)	—
Special length	X06 (6m) ~ X10 (10m)	—
	X11 (11m) ~ X15 (15m)	—
	X16 (16m) ~ X20 (20m)	—
Robot Cable	R01 (1m) ~ R03 (3m)	—
	R04 (4m) ~ R05 (5m)	—
	R06 (6m) ~ R10 (10m)	—
	R11 (11m) ~ R15 (15m)	—
	R16 (16m) ~ R20 (20m)	—

\* See page A-59 for cables for maintenance.

#### ④ Options

Name	Option code	See page	Standard price
Brake	B	→ A-42	—
Foot bracket	FT	→ A-49	—
High-acceleration/deceleration (*1)	HA	→ A-50	—
Home sensor (*2)	HS	→ A-50	—
Power-saving (*3)	LA	→ A-52	—
Non-motor end specification	NM	→ A-52	—
Trunnion bracket (back)	TRR	→ A-58	—

(\*1) The high-acceleration/deceleration option is not available for 2.5mm-lead model.  
 (\*2) The home sensor (HS) cannot be used on the non-motor end models.  
 (\*3) The high-acceleration/deceleration option and the power-saving option cannot be used simultaneously.

#### Actuator Specifications

Item	Description
Drive System	Ball screw, ø8mm, rolled C10
Positioning Repeatability	±0.02mm
Lost Motion	0.1mm or less
Guide	Single guide (guide rod diameter ø8mm, Ball bush type)
Rod diameter	ø16mm
Non-rotating accuracy of rod	±0.05 deg
Ambient operating temperature, humidity	0 to 40°C, 85% RH or less (Non-condensing)

Dimensional Drawings

CAD drawings can be downloaded from the website. [www.intelligentactuator.com](http://www.intelligentactuator.com)



[No Brake]

- (\*1) Connect the motor and encoder cables here. See page A-59 for details on cables.
  - (\*2) After homing, the slider moves to the ME, therefore, please watch for any interference with surrounding objects.
- ME : Mechanical end SE : Stroke end

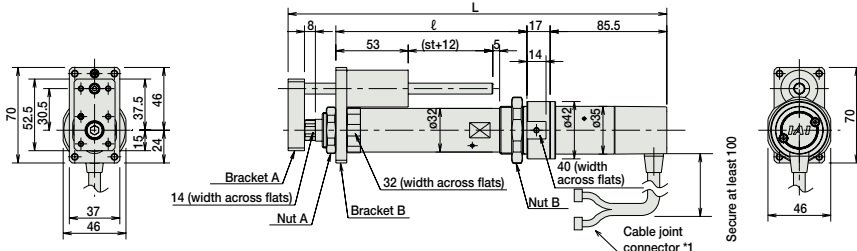
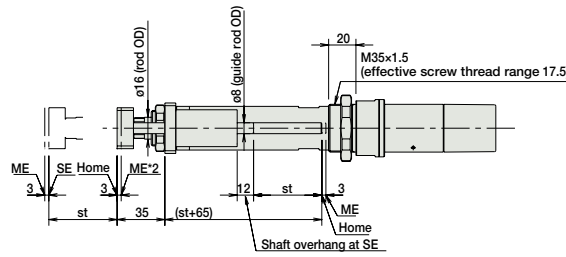

[Brake-Equipped]

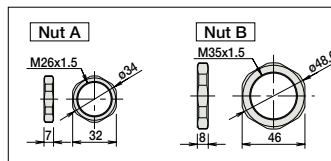
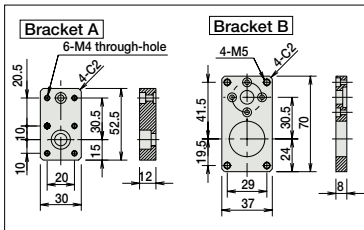
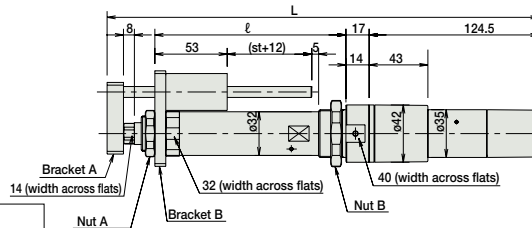

■ Dimensions and Weight by Stroke  
RCA-RGS3C (without brake)

Stroke	50	100	150	200
L	277.5	327.5	377.5	427.5
ℓ	140	190	240	290
Weight (kg)	0.9	1.1	1.2	1.3

RCA-RGS3C (with brake)

Stroke	50	100	150	200
L	316.5	366.5	416.5	466.5
ℓ	140	190	240	290
Weight (kg)	1.1	1.3	1.4	1.5

② Applicable Controllers

RCA series actuators can be operated with the controllers indicated below. Select the type according to your intended application. \* ACON-CY also can be used.

Name	External view	Model number	Features	Maximum number of positioning points	Input power	Power-supply capacity	Standard price	Reference page
Solenoid Valve Type		AMEC-C-20SI①-②-2-1	Easy-to-use controller, even for beginners	3 points	AC100V	2.4A rated	—	→ P537
		ASEP-C-20SI①-②-2-0	Simple controller operable with the same signal as a solenoid valve					→ P547
Solenoid valve multi-axis type PIO specification		MSEP-C-③-④-⑤-2-0	Positioner type based on PIO control, allowing up to 8 axes to be connected	256 points	DC24V	(Standard) 1.7A rated 5.1A max.	—	→ P563
Solenoid valve multi-axis type Network specification		MSEP-C-③-④-⑤-0-0	Field network-ready positioner type, allowing up to 8 axes to be connected					
Positioner type		ACON-C-20SI①-②-2-0	Positioning is possible for up to 512 points	512 points	DC24V	(Power-saving) 1.7A rated 3.4A max.	—	→ P631
Safety-Compliant Positioner Type		ACON-CG-20SI①-②-2-0						
Pulse Train Input Type (Differential Line Driver)		ACON-PL-20SI①-②-2-0	Pulse train input type with differential line driver support	(—)	DC24V	(Power-saving) 1.7A rated 3.4A max.	—	→ P631
Pulse Train Input Type (Open Collector)		ACON-PO-20SI①-②-2-0	Pulse train input type with open collector support					
Serial Communication Type		ACON-SE-20SI①-N-0-0	Dedicated Serial Communication	64 points	DC24V	(Power-saving) 1.7A rated 3.4A max.	—	→ P675
Program Control Type		ASEL-CS-1-20SI①-②-2-0	Programmed operation is possible. Can operate up to 2 axes	1,500 points	DC24V	(Power-saving) 1.7A rated 3.4A max.	—	→ P675

\* This is for the single-axis ASEL. \* Enter the code "HA" or "LA" in ① when the high-acceleration/deceleration option or the power-saving option is specified.  
 \* ① indicates I/O type (NP/PN). \* ③ indicates number of axes (1 to 8). \* ④ indicates field network specification symbol.

# RCA-RGS4C

Robo Cylinder, Rod Type with Single Guide, ø37mm Diameter, 24V Servo Motor, Coupled

Model Specification Items	<b>RCA</b>	<b>—RGS4C—</b>	<input type="checkbox"/>	<input type="checkbox"/>	<input type="checkbox"/>	<input type="checkbox"/>	<input type="checkbox"/>	<input type="checkbox"/>	<input type="checkbox"/>
	Series	Type	Encoder type	Motor type	Lead	Stroke	Applicable controller	Cable length	Options
	I: Incremental A: Absolute <small>* Absolute encoder models can only use ASEL. When the actuator is used with the simple absolute encoder, the model is considered an incremental model.</small>	20: 20W Servo motor 30: 30W Servo motor	12: 12mm 6: 6mm 3: 3mm	50: 50mm 300: 300mm (50mm pitch increments)	A1: ACON ASEL A3: AMEC ASEP MSEP	N: None P: 1m S: 3m M: 5m X□□: Custom Length R□□: Robot Cable	See Options below.		

\* See page Pre-47 for details on the model descriptions.



**For High Acceleration/Deceleration**

**Power-saving**

(\*1)

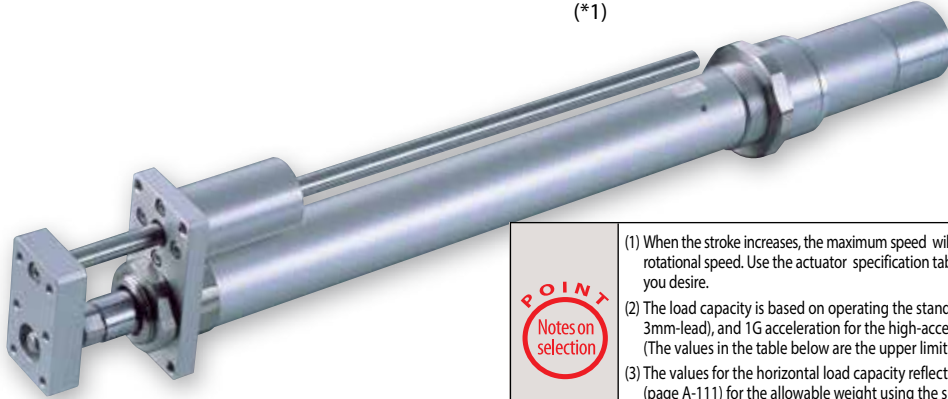

(\*1) Except all 20W models and 30W 3mm lead models

**Technical References** Appendix P.5

- POINT**  
Notes on selection
- (1) When the stroke increases, the maximum speed will drop to prevent the ball screw from reaching the critical rotational speed. Use the actuator specification table below to check the maximum speed at the stroke you desire.
  - (2) The load capacity is based on operating the standard and power-saving models at 0.3G (0.2G for 3mm-lead), and 1G acceleration for the high-acceleration models (3mm-lead model excluded). (The values in the table below are the upper limits, even if the acceleration/deceleration is decreased.)
  - (3) The values for the horizontal load capacity reflect the use of an external guide. See the technical resources (page A-111) for the allowable weight using the supplied guide alone.
  - (4) See page A-71 for details on push motion.

### Actuator Specifications

#### Leads and Payloads

Model number	Motor output (W)	Lead (mm)	Max. Load Capacity		Rated thrust (N)	Stroke (mm)
			Horizontal (kg)	Vertical (kg)		
RCA-RGS4C-①-20-12-②-③-④-⑤	20	12	3.0	0.5	18.9	50~300 (every 50mm)
RCA-RGS4C-①-20-6-②-③-④-⑤		6	6.0	1.5	37.7	
RCA-RGS4C-①-20-3-②-③-④-⑤		3	12.0	3.5	75.4	
RCA-RGS4C-①-30-12-②-③-④-⑤	30	12	4.0	1.0	28.3	
RCA-RGS4C-①-30-6-②-③-④-⑤		6	9.0	2.5	56.6	
RCA-RGS4C-①-30-3-②-③-④-⑤		3	18.0	6.0	113.1	

#### Stroke and Maximum Speed

Lead	Stroke	
	Stroke (mm)	50~300 (every 50mm)
12	600	
6	300	
3	150	

(Unit: mm/s)

Code explanation ① Encoder ② Stroke ③ Applicable controller ④ Cable length ⑤ Options \*See page A-71 for details on push motion.

#### ① Stroke

② Stroke (mm)	Standard price			
	① Encoder Type			
	Incremental		Absolute	
	Motor Output (W)		Motor Output (W)	
	20W	30W	20W	30W
50	—	—	—	—
100	—	—	—	—
150	—	—	—	—
200	—	—	—	—
250	—	—	—	—
300	—	—	—	—

#### ④ Cable Length

Type	Cable symbol	Standard Price
Standard	P (1m)	—
	S (3m)	—
	M (5m)	—
Special length	X06 (6m) ~ X10 (10m)	—
	X11 (11m) ~ X15 (15m)	—
	X16 (16m) ~ X20 (20m)	—
Robot Cable	R01 (1m) ~ R03 (3m)	—
	R04 (4m) ~ R05 (5m)	—
	R06 (6m) ~ R10 (10m)	—
	R11 (11m) ~ R15 (15m)	—
	R16 (16m) ~ R20 (20m)	—

\* See page A-59 for cables for maintenance.

#### ⑤ Options

Name	Option code	See page	Standard price
Brake	B	→ A-42	—
Foot bracket	FT	→ A-49	—
High-acceleration/deceleration (*1)	HA	→ A-50	—
Home sensor (*2)	HS	→ A-50	—
Power-saving (*3)	LA	→ A-52	—
Non-motor end specification	NM	→ A-52	—
Trunnion bracket (back)	TRR	→ A-58	—

(\*1) The high-acceleration/deceleration option is not available for all 20W models and 30W model with 3mm lead.  
 (\*2) The home sensor (HS) cannot be used on the non-motor end models.  
 (\*3) The high-acceleration/deceleration option and the power-saving option cannot be used simultaneously.

#### Actuator Specifications

Item	Description
Drive System	Ball screw, ø10mm, rolled C10
Positioning Repeatability	±0.02mm
Lost Motion	0.1mm or less
Guide	Single guide (guide rod diameter ø10mm, Ball bush type)
Rod diameter	ø20mm
Non-rotating accuracy of rod	±0.05 deg
Ambient operating temperature, humidity	0 to 40°C, 85% RH or less (Non-condensing)

Dimensional Drawings

CAD drawings can be downloaded from the website. [www.intelligentactuator.com](http://www.intelligentactuator.com)



[No Brake]

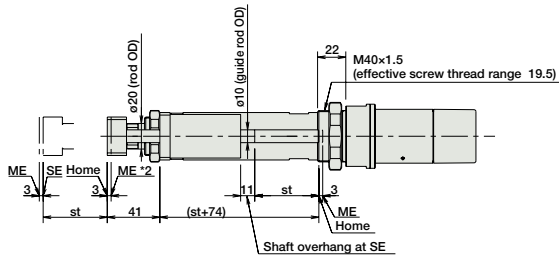

[Brake-Equipped]

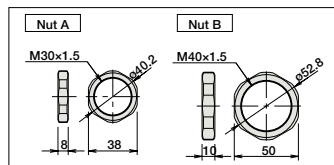
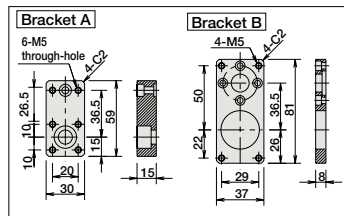
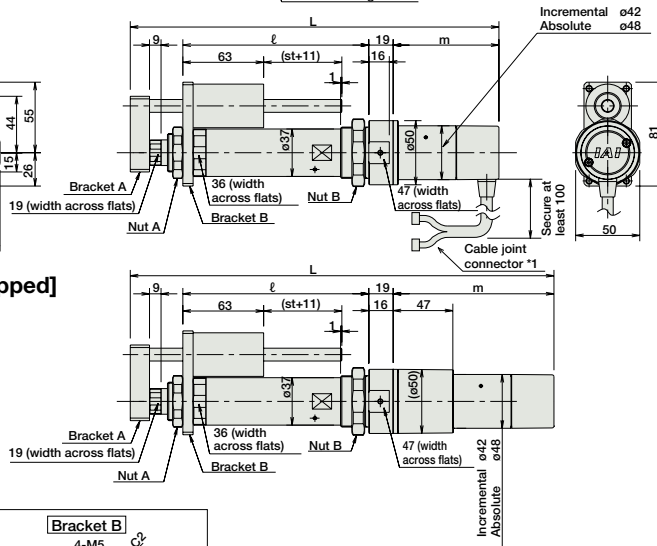

For Special Orders Appendix P.15

- (\*1) Connect the motor and encoder cables here. See page A-59 for details on cables.
- (\*2) After homing, the slider moves to the ME, therefore, please watch for any interference with surrounding objects. ME: Mechanical end SE: Stroke end

Dimensions and Weight by Stroke RCA-RGS4C (without brake)

Stroke	50	100	150	200	250	300		
L	20W	Increm.	272.5	322.5	372.5	422.5	472.5	522.5
		Absol.	285.5	335.5	385.5	435.5	485.5	535.5
	30W	Increm.	287.5	337.5	387.5	437.5	487.5	537.5
		Absol.	300.5	350.5	400.5	450.5	500.5	550.5
ℓ		145	195	245	295	345	395	
m	20W	Increm.	67.5					
		Absol.	80.5					
	30W	Increm.	82.5					
		Absol.	95.5					
Weight (kg)		1.5	1.6	1.8	2.0	2.2	2.4	

RCA-RGS4C (with brake)

Stroke	50	100	150	200	250	300		
L	20W	Increm.	315.5	365.5	415.5	465.5	515.5	565.5
		Absol.	328.5	378.5	428.5	478.5	528.5	578.5
	30W	Increm.	330.5	380.5	430.5	480.5	530.5	580.5
		Absol.	343.5	393.5	443.5	493.5	543.5	593.5
ℓ		145	195	245	295	345	395	
m	20W	Increm.	110.5					
		Absol.	123.5					
	30W	Increm.	125.5					
		Absol.	138.5					
Weight (kg)		1.7	1.8	2.0	2.2	2.4	2.6	

Applicable Controllers

RCA series actuators can be operated with the controllers indicated below. Select the type according to your intended application. \* ACON-CY also can be used.

Name	External view	Model number	Features	Maximum number of positioning points	Input power	Power-supply capacity	Standard price	Reference page
Solenoid Valve Type		AMEC-C-20I(II)-2-1 AMEC-C-30I(II)-2-1	Easy-to-use controller, even for beginners	3 points	AC100V	2.4A rated	—	→ P537
		ASEP-C-20I(II)-2-0 ASEP-C-30I(II)-2-0	Simple controller operable with the same signal as a solenoid valve					→ P547
Solenoid valve multi-axis type PIO specification		MSEP-C-IV-2-0	Positioner type based on PIO control, allowing up to 8 axes to be connected	256 points	DC24V	(Standard) 20W 1.3A rated 4.4A max. 30W 1.3A rated 4.4A max.	—	→ P563
Solenoid valve multi-axis type Network specification		MSEP-C-IV-V-0-0	Field network-ready positioner type, allowing up to 8 axes to be connected	512 points				
Positioner type		ACON-C-20I(II)-2-0 ACON-C-30I(II)-2-0	Positioning is possible for up to 512 points	512 points	DC24V	(Power-saving) 20W 1.3A rated 2.5A max. 30W 1.3A rated 2.2A max.	—	→ P631
Safety-Compliant Positioner Type		ACON-CG-20I(II)-2-0 ACON-CG-30I(II)-2-0						
Pulse Train Input Type (Differential Line Driver)		ACON-PL-20I(II)-2-0 ACON-PL-30I(II)-2-0	Pulse train input type with differential line driver support	(—)	DC24V	(Power-saving) 20W 1.3A rated 2.5A max. 30W 1.3A rated 2.2A max.	—	→ P631
Pulse Train Input Type (Open Collector)		ACON-PO-20I(II)-2-0 ACON-PO-30I(II)-2-0	Pulse train input type with open collector support					
Serial Communication Type		ACON-SE-20I(II)-N-0-0 ACON-SE-30I(II)-N-0-0	Dedicated Serial Communication	64 points	DC24V	—	—	—
Program Control Type		ASEL-CS-1-20I(II)-2-0 ASEL-CS-1-30I(II)-2-0	Programmed operation is possible. Can operate up to 2 axes	1,500 points	DC24V	—	—	→ P675

\* This is for the single-axis ASEL. \* (I) indicates encoder type (I: incremental, A: absolute) \* Enter the code "HA" or "LA" in (II) when the high-acceleration/deceleration option or the power-saving option is specified. \* (II) indicates I/O type (NP/PN). \* (IV) indicates number of axes (1 to 8). \* (V) indicates field network specification symbol.

- Slider Type
- Mini
- Standard
- Controller Integrated
- Rod Type
- Mini
- Standard
- Controllers Integrated
- Table/Arm/Flat Type
- Mini
- Standard
- Gripper/Rotary Type
- Linear Servo Type
- Clean-room Type
- Splash-Proof Type
- Pulse Motor
- Servo Motor (24V)
- Servo Motor (200V)
- Linear Servo Motor

# RCA-RGS3D

Robo Cylinder, Rod Type with Single Guide, ø32mm Diameter, 24V Servo Motor, Built-In Model

Model Specification Items	<b>RCA</b>	<b>-RGS3D-</b>	<b>I</b>	<b>- 20</b>	<input type="checkbox"/>	<input type="checkbox"/>	<input type="checkbox"/>	<input type="checkbox"/>	<input type="checkbox"/>
Series	Type	Encoder type	Motor type	Lead	Stroke	Applicable controller	Cable length	Options	
		I: Incremental * The Simple absolute encoder is also considered type "I".	20: 20W Servo motor	10 : 10mm 5 : 5mm 2.5: 2.5mm	50: 50mm { 200: 200mm (50mm pitch increments)	A1: ACON ASEL A3: AMEC ASEP MSEP	N: None P: 1m S: 3m M: 5m X□□: Custom Length R□□: Robot Cable	See Options below.	

\* See page Pre-47 for details on the model descriptions.

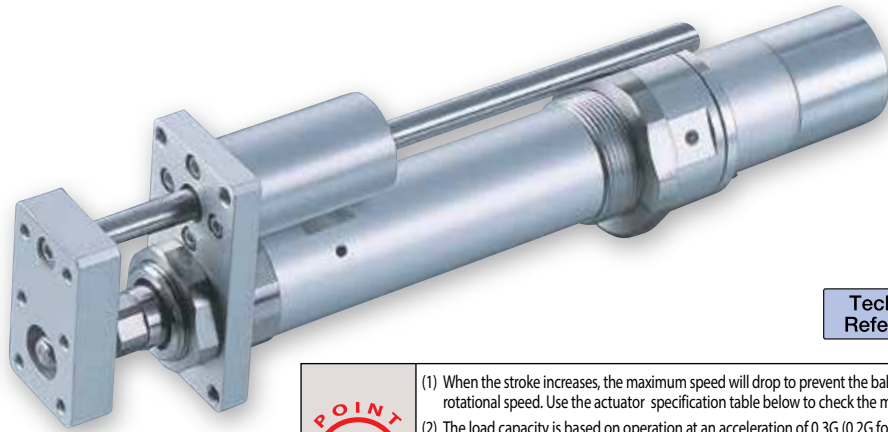

Power-saving

Technical References Appendix P.5



- (1) When the stroke increases, the maximum speed will drop to prevent the ball screw from reaching the critical rotational speed. Use the actuator specification table below to check the maximum speed at the stroke you desire.
- (2) The load capacity is based on operation at an acceleration of 0.3G (0.2G for the 2.5mm-lead model). This is the upper limit of the acceleration.
- (3) The values for the horizontal load capacity reflect the use of an external guide. See the technical resources (page A-110) for the allowable weight using the supplied guide alone.
- (4) See page A-71 for details on push motion.

## Actuator Specifications

### Leads and Payloads

Model number	Motor output (W)	Lead (mm)	Max. Load Capacity		Rated thrust (N)	Stroke (mm)
			Horizontal (kg)	Vertical (kg)		
RCA-RGS3D-I-20-10-①-②-③-④	20	10	4.0	1.2	36.2	50~200 (every 50mm)
RCA-RGS3D-I-20-5-①-②-③-④		5	9.0	2.7	72.4	
RCA-RGS3D-I-20-2.5-①-②-③-④		2.5	18.0	6.2	144.8	

### Stroke and Maximum Speed

Lead	Stroke	50~200 (every 50mm)
	10	500
5	250	250
2.5	125	125

Code explanation ① Stroke ② Applicable controller ③ Cable length ④ Options \*See page A-71 for details on push motion. (Unit: mm/s)

### ① Stroke

① Stroke (mm)	Standard price
50	—
100	—
150	—
200	—

### ③ Cable Length

Type	Cable symbol	Standard Price
Standard	P (1m)	—
	S (3m)	—
	M (5m)	—
Special length	X06 (6m) ~ X10 (10m)	—
	X11 (11m) ~ X15 (15m)	—
	X16 (16m) ~ X20 (20m)	—
	R01 (1m) ~ R03 (3m)	—
Robot Cable	R04 (4m) ~ R05 (5m)	—
	R06 (6m) ~ R10 (10m)	—
	R11 (11m) ~ R15 (15m)	—
	R16 (16m) ~ R20 (20m)	—
	—	—

\* See page A-59 for cables for maintenance.

### ④ Options

Name	Option code	See page	Standard price
Foot bracket	FT	→ A-49	—
Home sensor	HS	→ A-50	—
Power-saving	LA	→ A-52	—
Non-motor end specification	NM	→ A-52	—
Trunnion bracket (back)	TRR	→ A-58	—

\* The home sensor (HS) cannot be used on the non-motor end models.

### Actuator Specifications

Item	Description
Drive System	Ball screw, ø8mm, rolled C10
Positioning Repeatability	±0.02mm
Lost Motion	0.1mm or less
Guide	Single guide (guide rod diameter ø8mm, Ball bush type)
Rod diameter	ø16mm
Non-rotating accuracy of rod	±0.05 deg
Ambient operating temperature, humidity	0 to 40°C, 85% RH or less (Non-condensing)

Dimensional Drawings

CAD drawings can be downloaded from the website. [www.intelligentactuator.com](http://www.intelligentactuator.com)

For Special Orders Appendix P.15



- (\*1) Connect the motor and encoder cables here. See page A-59 for details on cables.
  - (\*2) After homing, the slider moves to the ME, therefore, please watch for any interference with surrounding objects.
- ME : Mechanical end SE : Stroke end

[No Brake]

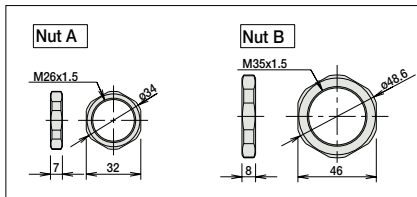
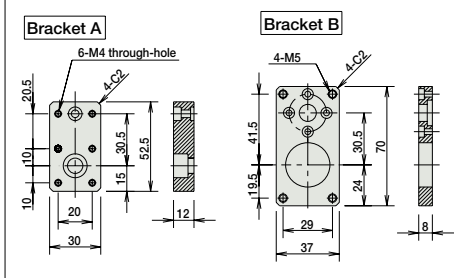
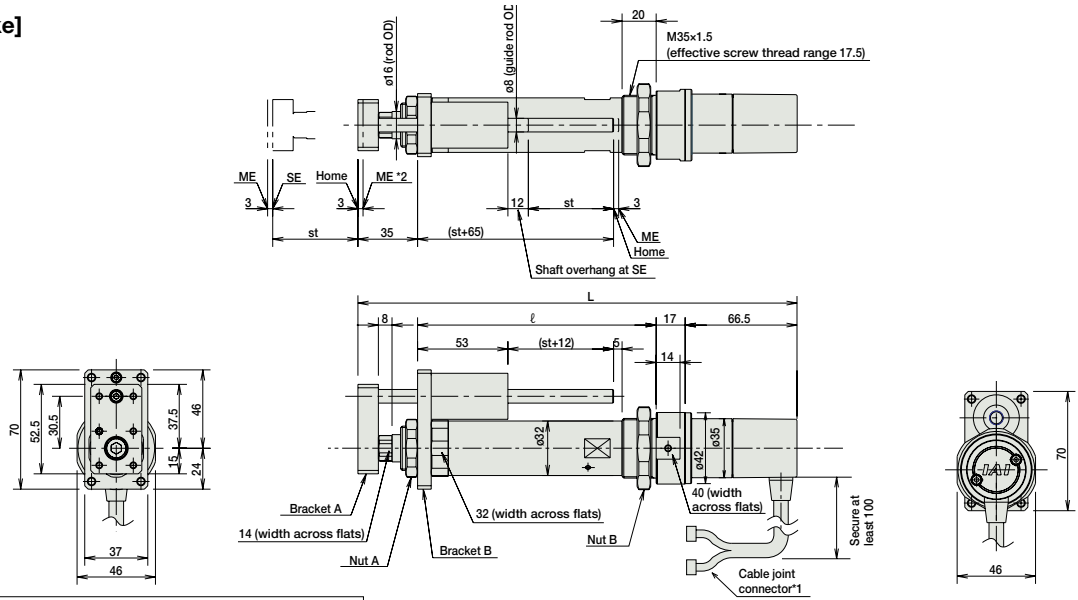

Dimensions and Weight by Stroke RCA-RGS3D (without brake)

Stroke	50	100	150	200
L	258.5	308.5	358.5	408.5
ℓ	140	190	240	290
Weight (kg)	0.9	1.1	1.2	1.3

RCA-RGS3D models are not equipped with a brake.

Applicable Controllers

RCA series actuators can be operated with the controllers indicated below. Select the type according to your intended application. \* ACON-CY also can be used.

Name	External view	Model number	Features	Maximum number of positioning points	Input power	Power-supply capacity	Standard price	Reference page
Solenoid Valve Type		AMEC-C-20SI①-②-2-1	Easy-to-use controller, even for beginners	3 points	AC100V	2.4A rated	—	→ P537
		ASEP-C-20SI①-②-2-0	Simple controller operable with the same signal as a solenoid valve					→ P547
Solenoid valve multi-axis type PIO specification		MSEP-C-③-④-⑤-2-0	Positioner type based on PIO control, allowing up to 8 axes to be connected	256 points	DC24V	(Standard) 1.7A rated 5.1A max.	—	→ P563
Solenoid valve multi-axis type Network specification		MSEP-C-③-④-⑤-0-0	Field network-ready positioner type, allowing up to 8 axes to be connected					
Positioner type		ACON-C-20SI①-②-2-0	Positioning is possible for up to 512 points	512 points	DC24V	(Standard) 1.7A rated 5.1A max.	—	→ P631
Safety-Compliant Positioner Type		ACON-CG-20SI①-②-2-0						
Pulse Train Input Type (Differential Line Driver)		ACON-PL-20SI①-②-2-0	Pulse train input type with differential line driver support	(—)	DC24V	(Power-saving) 1.7A rated 3.4A max.	—	→ P631
Pulse Train Input Type (Open Collector)		ACON-PO-20SI①-②-2-0	Pulse train input type with open collector support					
Serial Communication Type		ACON-SE-20SI①-N-0-0	Dedicated Serial Communication	64 points	DC24V	(Power-saving) 1.7A rated 3.4A max.	—	→ P675
Program Control Type		ASEL-CS-1-20SI①-②-2-0	Programmed operation is possible. Can operate up to 2 axes	1,500 points	DC24V	(Power-saving) 1.7A rated 3.4A max.	—	→ P675

\* This is for the single-axis ASEL. \* Enter the code "LA" in ① when the power-saving specification is specified.  
 \* ① indicates I/O type (NP/PN). \* ③ indicates number of axes (1 to 8). \* ④ indicates field network specification symbol.



RCA-RGS3D **240** ELECTROMATE  
 Toll Free Phone (877) SERV098  
 Toll Free Fax (877) SERV099  
[www.electromate.com](http://www.electromate.com)  
[sales@electromate.com](mailto:sales@electromate.com)

- Slider Type
- Mini
- Standard
- Controller Integrated
- Rod Type
- Mini
- Standard
- Controllers Integrated
- Table/Arm/Flat Type
- Mini
- Standard
- Gripper/Rotary Type
- Linear Servo Type
- Clean-room Type
- Splash-Proof Type
- Pulse Motor
- Servo Motor (24V)
- Servo Motor (200V)
- Linear Servo Motor



# RCA-RGS4D

Robo Cylinder, Rod Type with Single Guide, ø37mm Diameter, 24V Servo Motor, Built-In Model

Model Specification Items	<b>RCA</b>	<b>-RGS4D-</b>	<input type="checkbox"/>	<input type="checkbox"/>	<input type="checkbox"/>	<input type="checkbox"/>	<input type="checkbox"/>	<input type="checkbox"/>	<input type="checkbox"/>
	Series	Type	Encoder type	Motor type	Lead	Stroke	Applicable controller	Cable length	Options
			I: Incremental A: Absolute <small>* Absolute encoder models can only use ASEL. When the actuator is used with the simple absolute encoder, the model is considered an incremental model.</small>	20: 20W Servo motor 30: 30W Servo motor	12: 12mm 6: 6mm 3: 3mm	50: 50mm 300: 300mm (50mm pitch increments)	A1: ACON ASEL A3: AMEC ASEP MSEP	N: None P: 1m S: 3m M: 5m X <input type="checkbox"/> : Custom Length R <input type="checkbox"/> : Robot Cable	See Options below.

\* See page Pre-47 for details on the model descriptions.



Power-saving

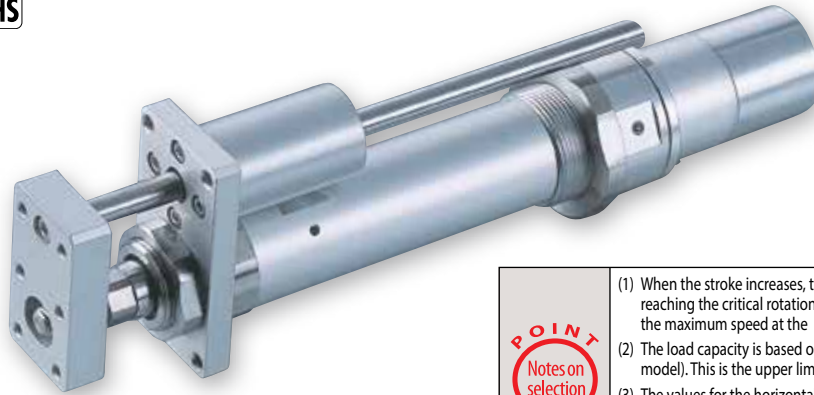

Technical References Appendix P.5

- POINT**  
Notes on selection
- When the stroke increases, the maximum speed will drop to prevent the ball screw from reaching the critical rotational speed. Use the actuator specification table below to check the maximum speed at the stroke you desire.
  - The load capacity is based on operation at an acceleration of 0.3G (0.2G for the 3mm-lead model). This is the upper limit of the acceleration.
  - The values for the horizontal load capacity reflect the use of an external guide. See the technical resources (page A-111) for the allowable weight using the supplied guide alone.
  - See page A-71 for details on push motion.

### Actuator Specifications

#### Leads and Payloads

Model number	Motor output (W)	Lead (mm)	Max. Load Capacity		Rated thrust (N)	Stroke (mm)
			Horizontal (kg)	Vertical (kg)		
RCA-RGS4D-①-20-12-②-③-④-⑤	20	12	3.0	0.5	18.9	50~300 (every 50mm)
RCA-RGS4D-①-20-6-②-③-④-⑤		6	6.0	1.5	37.7	
RCA-RGS4D-①-20-3-②-③-④-⑤		3	12.0	3.5	75.4	
RCA-RGS4D-①-30-12-②-③-④-⑤	30	12	4.0	1.0	28.3	
RCA-RGS4D-①-30-6-②-③-④-⑤		6	9.0	2.5	56.6	
RCA-RGS4D-①-30-3-②-③-④-⑤		3	18.0	6.0	113.1	

#### Stroke and Maximum Speed

Lead	Stroke	50~300 (every 50mm)
	12	
6		300
3		150

(Unit: mm/s)

Code explanation ① Encoder ② Stroke ③ Applicable controller ④ Cable length ⑤ Options \*See page A-71 for details on push motion.

#### ① Stroke

② Stroke (mm)	Standard price			
	① Encoder Type			
	Incremental		Absolute	
	Motor Output (W)		Motor Output (W)	
	20W	30W	20W	30W
50	—	—	—	—
100	—	—	—	—
150	—	—	—	—
200	—	—	—	—
250	—	—	—	—
300	—	—	—	—

#### ④ Cable Length

Type	Cable symbol	Standard Price
Standard	P (1m)	—
	S (3m)	—
	M (5m)	—
Special length	X06 (6m) ~ X10 (10m)	—
	X11 (11m) ~ X15 (15m)	—
	X16 (16m) ~ X20 (20m)	—
Robot Cable	R01 (1m) ~ R03 (3m)	—
	R04 (4m) ~ R05 (5m)	—
	R06 (6m) ~ R10 (10m)	—
	R11 (11m) ~ R15 (15m)	—
	R16 (16m) ~ R20 (20m)	—

\* See page A-59 for cables for maintenance.

#### ⑤ Options

Name	Option code	See page	Standard price
Foot bracket	FT	→ A-49	—
Home sensor	HS	→ A-50	—
Power-saving	LA	→ A-52	—
Non-motor end specification	NM	→ A-52	—
Trunnion bracket (back)	TRR	→ A-58	—

\*The home sensor (HS) cannot be used on the non-motor end models.

#### Actuator Specifications

Item	Description
Drive System	Ball screw, ø10mm, rolled C10
Positioning Repeatability	±0.02mm
Lost Motion	0.1mm or less
Guide	Single guide (guide rod diameter ø10mm, Ball bush type)
Rod diameter	ø20mm
Non-rotating accuracy of rod	±0.05 deg
Ambient operating temperature, humidity	0 to 40°C, 85% RH or less (Non-condensing)

241 RCA-RGS4D

Dimensional Drawings

CAD drawings can be downloaded from the website. [www.intelligentactuator.com](http://www.intelligentactuator.com)

For Special Orders Appendix P.15



[No Brake]

- (\*1) Connect the motor and encoder cables here. See page A-59 for details on cables.
- (\*2) After homing, the slider moves to the ME, therefore, please watch for any interference with surrounding objects.  
ME : Mechanical end SE : Stroke end

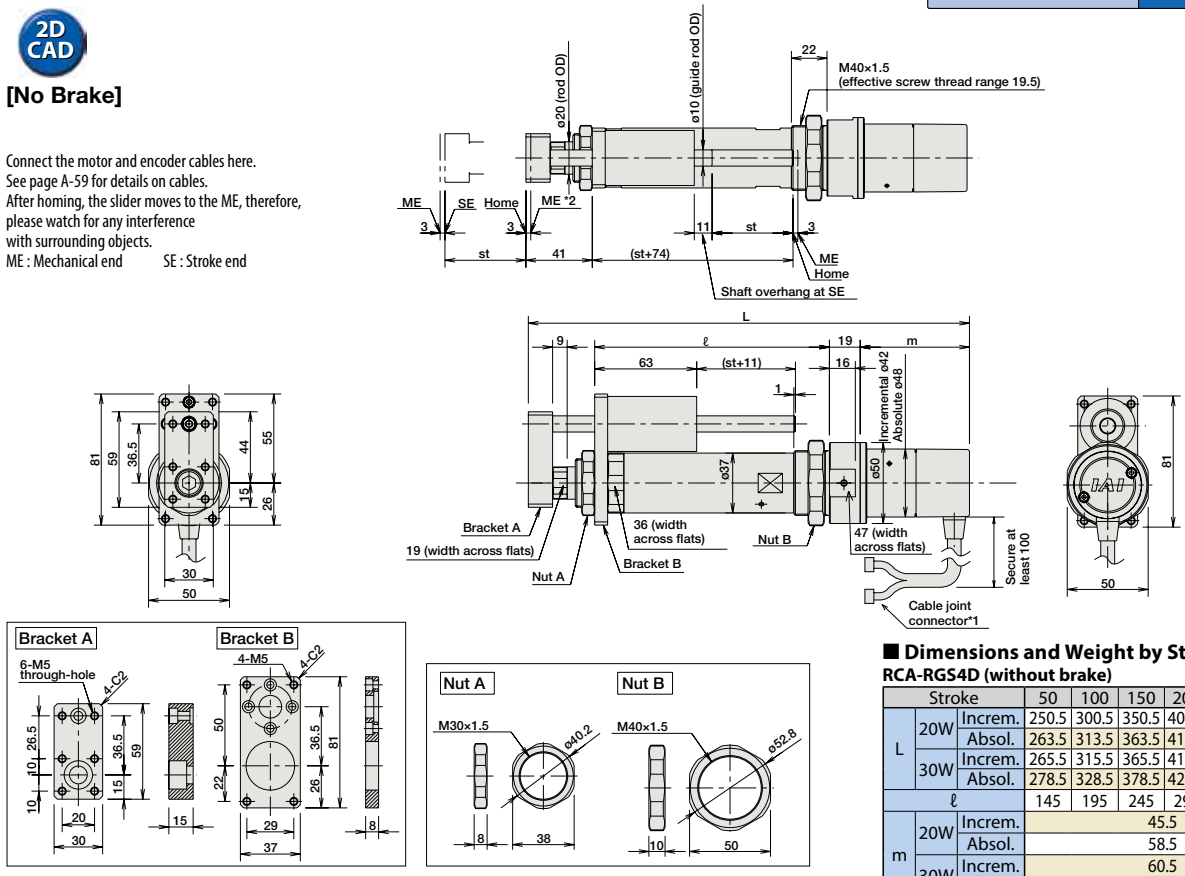

Dimensions and Weight by Stroke RCA-RGS4D (without brake)

Stroke	Weight (kg)							
	50	100	150	200	250	300		
L	20W	Incremental	250.5	300.5	350.5	400.5	450.5	500.5
		Absolute	263.5	313.5	363.5	413.5	463.5	513.5
	30W	Incremental	265.5	315.5	365.5	415.5	465.5	515.5
		Absolute	278.5	328.5	378.5	428.5	478.5	528.5
l			145	195	245	295	345	395
m	20W	Incremental	45.5					
		Absolute	58.5					
	30W	Incremental	60.5					
		Absolute	73.5					
Weight (kg)			1.3	1.5	1.7	1.9	2.1	2.3

RCA-RGS4D models are not equipped with a brake.

Applicable Controllers

RCA series actuators can be operated with the controllers indicated below. Select the type according to your intended application. \* ACON-CY also can be used.

Name	External view	Model number	Features	Maximum number of positioning points	Input power	Power-supply capacity	Standard price	Reference page
Solenoid Valve Type		AMEC-C-20I(①)-(②)-2-1 AMEC-C-30I(①)-(②)-2-1	Easy-to-use controller, even for beginners	3 points	AC100V	2.4A rated	—	→ P537
		ASEP-C-20I(①)-(②)-2-0 ASEP-C-30I(①)-(②)-2-0	Simple controller operable with the same signal as a solenoid valve					→ P547
Solenoid valve multi-axis type PIO specification		MSEP-C-(④)-(⑤)-(⑥)-2-0	Positioner type based on PIO control, allowing up to 8 axes to be connected	256 points	DC24V	(Standard) 20W 1.3A rated 4.4A max. 30W 1.3A rated 4.4A max.	—	→ P563
Solenoid valve multi-axis type Network specification		MSEP-C-(④)-(⑤)-(⑥)-0-0	Field network-ready positioner type, allowing up to 8 axes to be connected					→ P631
Positioner type		ACON-C-20I(①)-(②)-2-0 ACON-C-30I(①)-(②)-2-0	Positioning is possible for up to 512 points	512 points	DC24V	(Power-saving) 20W 1.3A rated 2.5A max. 30W 1.3A rated 2.2A max.	—	→ P631
Safety-Compliant Positioner Type		ACON-CG-20I(①)-(②)-2-0 ACON-CG-30I(①)-(②)-2-0						
Pulse Train Input Type (Differential Line Driver)		ACON-PL-20I(①)-(②)-2-0 ACON-PL-30I(①)-(②)-2-0	Pulse train input type with differential line driver support	(—)	DC24V	(Power-saving) 20W 1.3A rated 2.5A max. 30W 1.3A rated 2.2A max.	—	→ P631
Pulse Train Input Type (Open Collector)		ACON-PO-20I(①)-(②)-2-0 ACON-PO-30I(①)-(②)-2-0	Pulse train input type with open collector support					
Serial Communication Type		ACON-SE-20I(①)-N-0-0 ACON-SE-30I(①)-N-0-0	Dedicated Serial Communication	64 points	DC24V	(Power-saving) 20W 1.3A rated 2.5A max. 30W 1.3A rated 2.2A max.	—	→ P675
Program Control Type		ASEL-CS-1-20I(①)-(②)-2-0 ASEL-CS-1-30I(①)-(②)-2-0	Programmed operation is possible. Can operate up to 2 axes	1,500 points	DC24V	(Power-saving) 20W 1.3A rated 2.5A max. 30W 1.3A rated 2.2A max.	—	→ P675

\* This is for the single-axis ASEL. \* ① indicates encoder type (I: incremental, A: absolute) \* Enter the code "LA" in ① when the power-saving specification is specified.  
 \* ② indicates I/O type (NP/PN). \* ④ indicates number of axes (1 to 8). \* ⑤ indicates field network specification symbol.



RCA2-RGS4D **242** ELECTROMATE  
 Toll Free Phone (877) SERV098  
 Toll Free Fax (877) SERV099  
[www.electromate.com](http://www.electromate.com)  
[sales@electromate.com](mailto:sales@electromate.com)

- Slider Type
- Mini
- Standard
- Controller Integrated
- Rod Type
- Mini
- Standard
- Controllers Integrated
- Table/Arm/Flat Type
- Mini
- Standard
- Gripper/Rotary Type
- Linear Servo Type
- Clean-room Type
- Splash-Proof Type
- Pulse Motor
- Servo Motor (24V)
- Servo Motor (200V)
- Linear Servo Motor

# RCA-SRGS4R

Robo Cylinder, Rod Type with Single Guide, Actuator Width 45mm, Servo Motor, Short-Length Model, Side-Mounted Motor

Model Specification Items	<b>RCA</b>	<b>SRGS4R</b>	<b>I</b>	<b>20</b>	<input type="checkbox"/>	<input type="checkbox"/>	<input type="checkbox"/>	<input type="checkbox"/>	<input type="checkbox"/>
	Series	Type	Encoder type	Motor type	Lead	Stroke	Applicable controller	Cable length	Options
			I: Incremental * The Simple absolute encoder is also considered type "I".	20: 20W Servo motor	5 : 5mm 2.5: 2.5mm	20: 20mm { 200: 200mm (* Set in 50mm increments over 100mm)	A1: ACON ASEL A3: AMEC ASEP MSEP	N: None P: 1m S: 3m M: 5m X <input type="checkbox"/> : Custom Length	See Options below.

\* See page Pre-47 for details on the model descriptions.



Power-saving



Technical References Appendix P.5



- (1) The load capacity is based on operation at an acceleration of 0.3G (0.2G for the 2.5mm-lead model, or when used vertically). This is the upper limit of the acceleration.
- (2) The values for the horizontal load capacity reflect the use of an external guide. See the technical resources (page A-111) for the allowable weight using the supplied guide alone.
- (3) See page A-71 for details on push motion.

## Actuator Specifications

### Leads and Payloads

(Note A) 50mm increments over 100mm.

Model number	Motor output (W)	Lead (mm)	Max. Load Capacity		Rated thrust (N)	Stroke (mm)
			Horizontal (kg)	Vertical (kg)		
RCA-SRGS4R-I-20-5-①-②-③-④	20	5	9 (Note1)	2	41	20~200 (every 10mm) (Note A)
RCA-SRGS4R-I-20-2.5-①-②-③-④		2.5	18 (Note1)	5.5		

### Stroke and Maximum Speed

Lead	Stroke	20~200 (every 10mm)
	5	
2.5		125

Code explanation ① Stroke ② Applicable controller ③ Cable length ④ Options \*See page A-71 for details on push motion. (Unit: mm/s)

### ① Stroke

① Stroke (mm)	Standard price
20~50	—
60~100	—
150	—
200	—

### ③ Cable Length

Type	Cable symbol	Standard Price
Standard (Robot Cables)	P (1m)	—
	S (3m)	—
	M (5m)	—
Special length	X06 (6m) ~ X10 (10m)	—
	X11 (11m) ~ X15 (15m)	—
	X16 (16m) ~ X20 (20m)	—

\* The cable is a motor-encoder integrated cable, and is provided as a robot cable.  
\* See page A-59 for cables for maintenance.

### ④ Options

Name	Option code	See page	Standard price
Brake	B	→ A-42	—
Flange bracket (back)	FLR	→ A-46	—
Foot bracket 2 (right/left side mounting)	FT2/FT4	→ A-50	—
Guide mounting direction	GS2 ~ GS4	→ A-50	—
Power-saving	LA	→ A-52	—
Non-motor end specification	NM	→ A-52	—

\* The brake is available for strokes of 70mm or more.  
\* Please be sure that the mounting direction of the guide is specified in the product name.  
\* The guide and the foot bracket cannot be mounted in the same direction.  
(Combination of GS2 and FT4, GS4 and FT2 can be mounted. The foot bracket cannot be mounted in the GS3 direction.)

## Actuator Specifications

Item	Description
Drive System	Ball screw, ø8mm, rolled C10
Positioning Repeatability	±0.02mm
Lost Motion	0.1mm or less
Rod diameter	ø22mm
Non-rotating accuracy of rod	±0.05 deg
Ambient operating temperature, humidity	0 to 40°C, 85% RH or less (Non-condensing)

243 RCA-SRGS4R

Dimensional Drawings

CAD drawings can be downloaded from the website. [www.intelligentactuator.com](http://www.intelligentactuator.com)

For Special Orders Appendix P.15

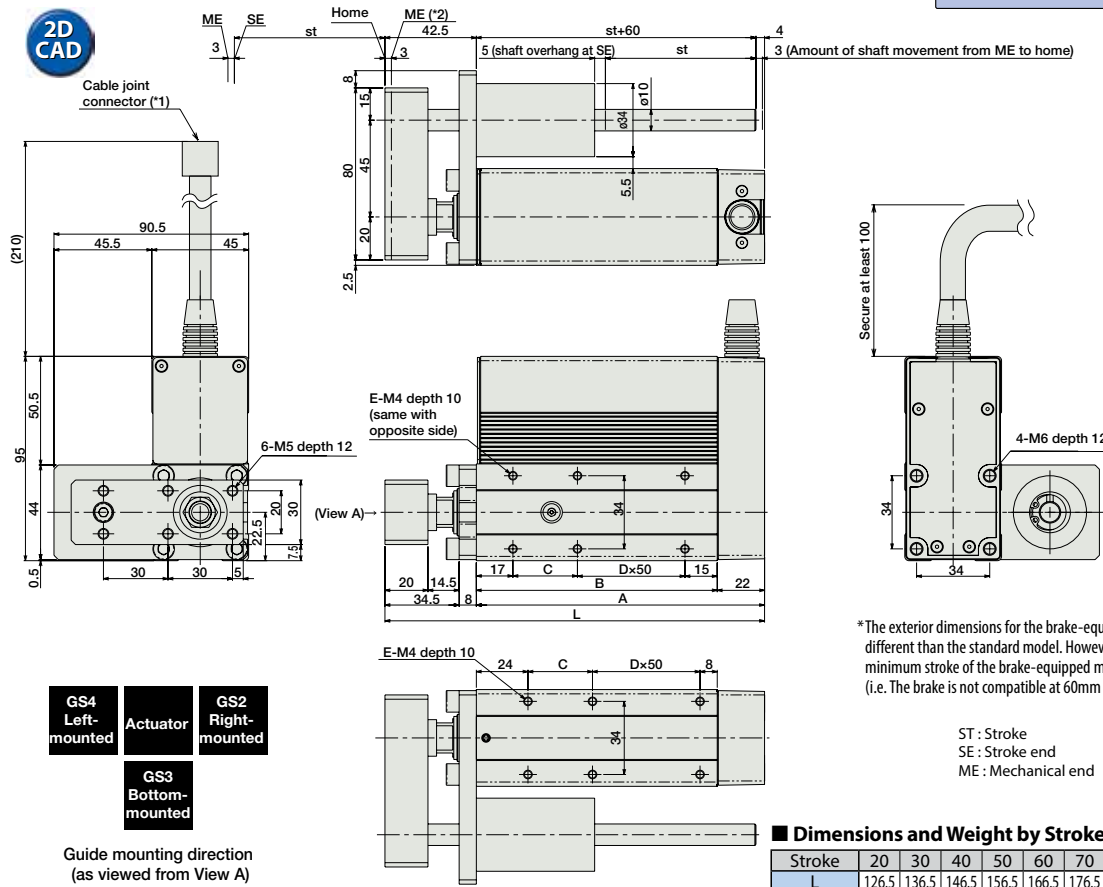

\*The exterior dimensions for the brake-equipped model is no different than the standard model. However, 70mm is the minimum stroke of the brake-equipped models. (i.e. The brake is not compatible at 60mm strokes and under.)

ST : Stroke  
SE : Stroke end  
ME : Mechanical end

■ Dimensions and Weight by Stroke (Add 0.2kg for brake equipped)

Stroke	20	30	40	50	60	70	80	90	100	150	200
L	126.5	136.5	146.5	156.5	166.5	176.5	186.5	196.5	206.5	256.5	306.5
A	84	94	104	114	124	134	144	154	164	214	264
B	62	72	82	92	102	112	122	132	142	192	242
C	30	40	50	60	70	30	40	50	60	60	60
D	0	0	0	0	0	1	1	1	1	2	3
E	4	4	4	4	4	6	6	6	6	8	10
Weight (kg)	1.15	1.21	1.28	1.35	1.42	1.49	1.56	1.62	1.69	2.03	2.38

(\*1) Connect the motor-encoder integrated cable here. See page A-59 for details on cables.  
(\*2) After homing, the slider moves to the ME, therefore, please watch for any interference with surrounding objects.

② Applicable Controllers

RCA series actuators can be operated with the controllers indicated below. Select the type according to your intended application. \* ACON-CY also can be used.

Name	External view	Model number	Features	Maximum number of positioning points	Input power	Power-supply capacity	Standard price	Reference page
Solenoid Valve Type		AMEC-C-20I①-②-2-1	Easy-to-use controller, even for beginners	3 points	AC100V	2.4A rated	—	→ P537
		ASEP-C-20I①-②-2-0	Simple controller operable with the same signal as a solenoid valve					→ P547
Solenoid valve multi-axis type PIO specification		MSEP-C-③-④-2-0	Positioner type based on PIO control, allowing up to 8 axes to be connected	256 points	DC24V	(Standard) 1.3A rated 4.4A max. (Power-saving) 1.3A rated 2.5A max.	—	→ P563
Solenoid valve multi-axis type Network specification		MSEP-C-③-④-0-0	Field network-ready positioner type, allowing up to 8 axes to be connected					
Positioner type		ACON-C-20I①-②-2-0	Positioning is possible for up to 512 points	512 points	DC24V	(Standard) 1.3A rated 4.4A max. (Power-saving) 1.3A rated 2.5A max.	—	→ P631
Safety-Compliant Positioner Type		ACON-CG-20I①-②-2-0						
Pulse Train Input Type (Differential Line Driver)		ACON-PL-20I①-②-2-0	Pulse train input type with differential line driver support	(—)	DC24V	(Standard) 1.3A rated 4.4A max. (Power-saving) 1.3A rated 2.5A max.	—	→ P631
Pulse Train Input Type (Open Collector)		ACON-PO-20I①-②-2-0	Pulse train input type with open collector support					
Serial Communication Type		ACON-SE-20I①-N-0-0	Dedicated Serial Communication	64 points	DC24V	(Standard) 1.3A rated 4.4A max. (Power-saving) 1.3A rated 2.5A max.	—	→ P675
Program Control Type		ASEL-CS-1-20I①-②-2-0	Programmed operation is possible. Can operate up to 2 axes	1,500 points	DC24V	(Standard) 1.3A rated 4.4A max. (Power-saving) 1.3A rated 2.5A max.	—	→ P675

\* This is for the single-axis ASEL. \* Enter the code "LA" in ① when the power-saving specification is specified. \* ② indicates I/O type (NP/PN).  
\* ③ indicates number of axes (1 to 8). \* ④ indicates field network specification symbol.

- Slider Type
- Mini
- Standard
- Controller Integrated
- Rod Type
- Mini
- Standard
- Controllers Integrated
- Table/Arm/Flat Type
- Mini
- Standard
- Gripper/Rotary Type
- Linear Servo Type
- Clean-room Type
- Splash-Proof Type
- Pulse Motor
- Servo Motor (24V)
- Servo Motor (200V)
- Linear Servo Motor

# RCA-RGD3C

Robo Cylinder, Rod Type with Double Guide, ø32mm Diameter, 24V Servo Motor, Coupled

Model Specification Items	<b>RCA</b>	<b>— RGD3C</b>	<b>— I</b>	<b>— 20</b>	<input type="checkbox"/>	<input type="checkbox"/>	<input type="checkbox"/>	<input type="checkbox"/>	<input type="checkbox"/>
	Series	Type	Encoder type	Motor type	Lead	Stroke	Applicable controller	Cable length	Options
			I: Incremental * The Simple absolute encoder is also considered type "I".	20: 20W Servo motor	10: 10mm 5: 5mm 2.5: 2.5mm	50: 50mm { 200: 200mm (50mm pitch increments)	A1: ACON ASEL A3: AMEC ASEP MSEP	N: None P: 1m S: 3m M: 5m X <input type="checkbox"/> : Custom Length R <input type="checkbox"/> : Robot Cable	See Options below.

\* See page Pre-47 for details on the model descriptions.



**For High Acceleration/Deceleration**

**Power-saving**

(excluding the 2.5mm-lead model)

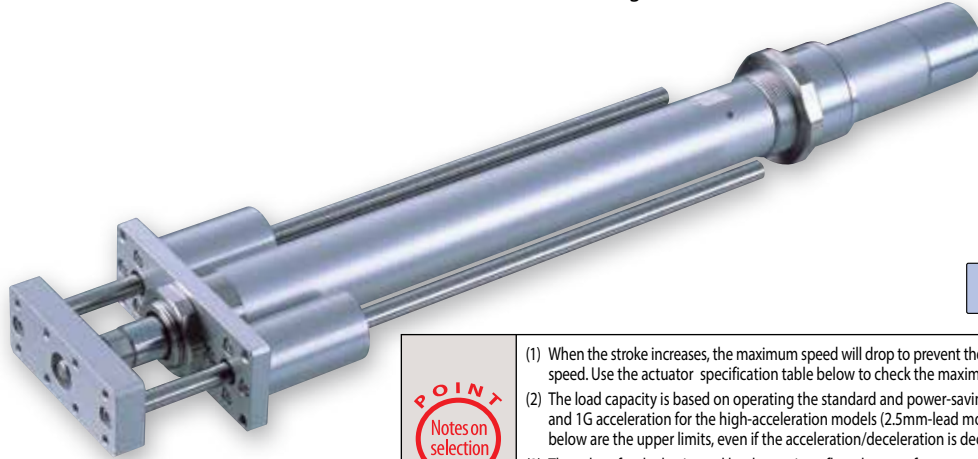

Technical References Appendix P.5

- POINT**  
Notes on selection
- When the stroke increases, the maximum speed will drop to prevent the ball screw from reaching the critical rotational speed. Use the actuator specification table below to check the maximum speed at the stroke you desire.
  - The load capacity is based on operating the standard and power-saving models at 0.3G (0.2G for 2.5mm-lead), and 1G acceleration for the high-acceleration models (2.5mm-lead model excluded). The values in the table below are the upper limits, even if the acceleration/deceleration is decreased.
  - The values for the horizontal load capacity reflect the use of an external guide. See the technical resources (page A-112) for the allowable weight using the supplied guide alone.
  - See page A-71 for details on push motion.

### Actuator Specifications

#### Leads and Payloads

Model number	Motor output (W)	Lead (mm)	Max. Load Capacity		Rated thrust (N)	Stroke (mm)
			Horizontal (kg)	Vertical (kg)		
RCA-RGD3C-I-20-10- <input type="checkbox"/> - <input type="checkbox"/> - <input type="checkbox"/> - <input type="checkbox"/>	20	10	4.0	1.2	36.2	50~200 (every 50mm)
RCA-RGD3C-I-20-5- <input type="checkbox"/> - <input type="checkbox"/> - <input type="checkbox"/> - <input type="checkbox"/>		5	9.0	2.7	72.4	
RCA-RGD3C-I-20-2.5- <input type="checkbox"/> - <input type="checkbox"/> - <input type="checkbox"/> - <input type="checkbox"/>		2.5	18.0	6.2	144.8	

#### Stroke and Maximum Speed

Stroke / Lead	50~200 (every 50mm)
	10
5	250
2.5	125

Code explanation  Stroke  Applicable controller  Cable length  Options \*See page A-71 for details on push motion. (Unit: mm/s)

#### ① Stroke

① Stroke (mm)	Standard price
50	—
100	—
150	—
200	—

#### ③ Cable Length

Type	Cable symbol	Standard Price
Standard	P (1m)	—
	S (3m)	—
	M (5m)	—
Special length	X06 (6m) ~ X10 (10m)	—
	X11 (11m) ~ X15 (15m)	—
	X16 (16m) ~ X20 (20m)	—
	R01 (1m) ~ R03 (3m)	—
Robot Cable	R04 (4m) ~ R05 (5m)	—
	R06 (6m) ~ R10 (10m)	—
	R11 (11m) ~ R15 (15m)	—
	R16 (16m) ~ R20 (20m)	—

\* See page A-59 for cables for maintenance.

#### ④ Options

Name	Option code	See page	Standard price
Brake	B	→ A-42	—
Foot bracket	FT	→ A-49	—
High-acceleration/deceleration (*1)	HA	→ A-50	—
Home sensor (*2)	HS	→ A-50	—
Power-saving (*3)	LA	→ A-52	—
Non-motor end specification	NM	→ A-52	—
Trunnion bracket (back)	TRR	→ A-58	—

(\*1) The high-acceleration/deceleration option is not available for 2.5mm-lead model.

(\*2) The home sensor (HS) cannot be used on the non-motor end models.

(\*3) The high-acceleration/deceleration option and the power-saving option cannot be used simultaneously.

#### Actuator Specifications

Item	Description
Drive System	Ball screw, ø8mm, rolled C10
Positioning Repeatability	±0.02mm
Lost Motion	0.1mm or less
Guide	Single guide (guide rod diameter ø8mm, Ball bush type)
Rod diameter	ø16mm
Non-rotating accuracy of rod	±0.05 deg
Ambient operating temperature, humidity	0 to 40°C, 85% RH or less (Non-condensing)

# 245

RCA-RGD3C

Dimensional Drawings

CAD drawings can be downloaded from the website. [www.intelligentactuator.com](http://www.intelligentactuator.com)

For Special Orders Appendix P.15



- (\*1) Connect the motor and encoder cables here. See page A-59 for details on cables.
  - (\*2) After homing, the slider moves to the ME, therefore, please watch for any interference with surrounding objects.
- ME : Mechanical end SE : Stroke end

[No Brake]

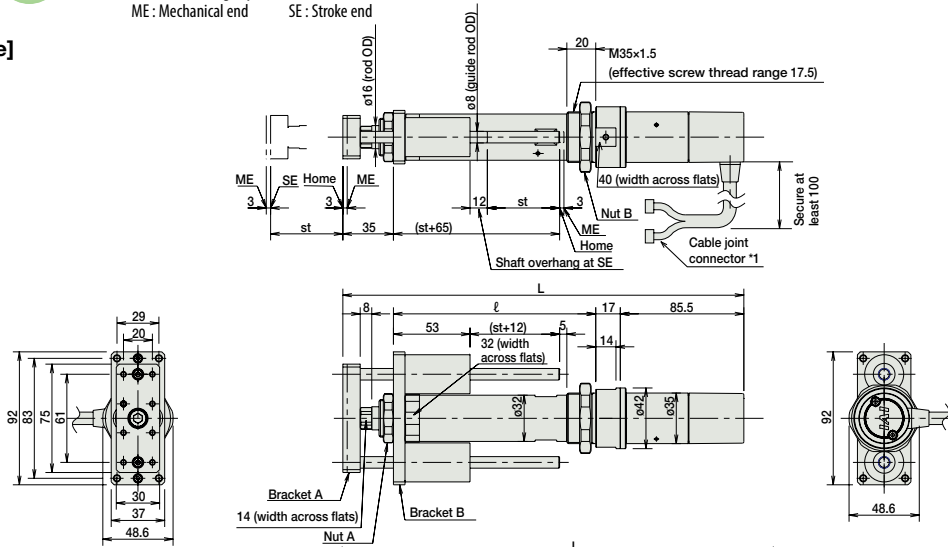

[Brake-Equipped]

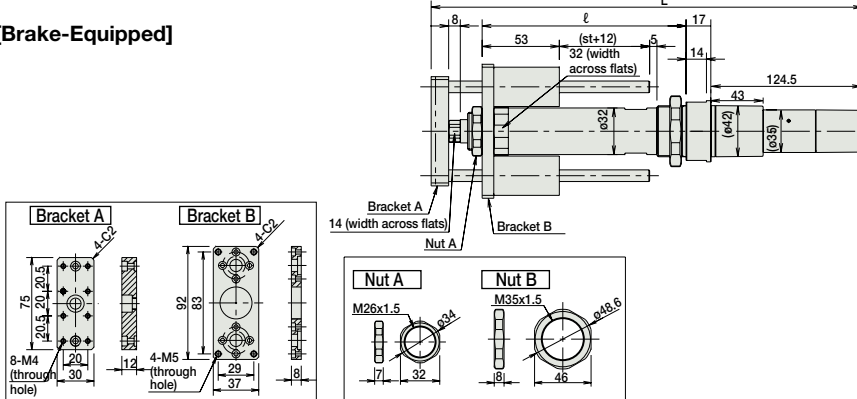

Dimensions and Weight by Stroke RCA-RGD3C (without brake)

Stroke	50	100	150	200
L	277.5	327.5	377.5	427.5
ℓ	140	190	240	290
Weight (kg)	1.1	1.2	1.4	1.5

RCA-RGD3C (with brake)

Stroke	50	100	150	200
L	316.5	366.5	416.5	466.5
ℓ	140	190	240	290
Weight (kg)	1.3	1.4	1.6	1.7

Applicable Controllers

RCA series actuators can be operated with the controllers indicated below. Select the type according to your intended application. \* ACON-CY also can be used.

Name	External view	Model number	Features	Maximum number of positioning points	Input power	Power-supply capacity	Standard price	Reference page
Solenoid Valve Type		AMEC-C-20SI①-②-2-1	Easy-to-use controller, even for beginners	3 points	AC100V	2.4A rated	—	→ P537
		ASEP-C-20SI①-②-2-0	Simple controller operable with the same signal as a solenoid valve					→ P547
Solenoid valve multi-axis type PIO specification		MSEP-C-③-④-2-0	Positioner type based on PIO control, allowing up to 8 axes to be connected	256 points	DC24V	(Standard) 1.7A rated 5.1A max.	—	→ P563
Solenoid valve multi-axis type Network specification		MSEP-C-③-④-0-0	Field network-ready positioner type, allowing up to 8 axes to be connected					
Positioner type		ACON-C-20SI①-②-2-0	Positioning is possible for up to 512 points	512 points	DC24V	(Power-saving) 1.7A rated 3.4A max.	—	→ P631
Safety-Compliant Positioner Type		ACON-CG-20SI①-②-2-0						
Pulse Train Input Type (Differential Line Driver)		ACON-PL-20SI①-②-2-0	Pulse train input type with differential line driver support	(—)	DC24V	(Power-saving) 1.7A rated 3.4A max.	—	→ P631
Pulse Train Input Type (Open Collector)		ACON-PO-20SI①-②-2-0	Pulse train input type with open collector support					
Serial Communication Type		ACON-SE-20SI①-N-0-0	Dedicated Serial Communication	64 points	DC24V	(Power-saving) 1.7A rated 3.4A max.	—	→ P631
Program Control Type		ASEL-CS-1-20SI①-②-2-0	Programmed operation is possible. Can operate up to 2 axes	1,500 points	DC24V	(Power-saving) 1.7A rated 3.4A max.	—	→ P675

\* This is for the single-axis ASEL. \* Enter the code "HA" or "LA" in ① when the high-acceleration/deceleration option or the power-saving option is specified.  
 \* ① indicates I/O type (NP/PN). \* ③ indicates number of axes (1 to 8). \* ④ indicates field network specification symbol.

# RCA-RGD4C

Robo Cylinder, Rod Type with Double Guide, ø37mm Diameter, 24V Servo Motor, Coupled

Model Specification Items	<b>RCA</b> — <b>RGD4C</b> —	—	—	—	—	—	—	—	—
	Series	Type	Encoder type	Motor type	Lead	Stroke	Applicable controller	Cable length	Options
	I: Incremental A: Absolute <small>* Absolute encoder models can only use ASEL. When the actuator is used with the simple absolute encoder, the model is considered an incremental model.</small>	20: 20W Servo motor 30: 30W Servo motor	12: 12mm 6: 6mm 3: 3mm	50: 50mm 300: 300mm (50mm pitch increments)	A1: ACON ASEL A3: AMEC ASEP MSEP	N: None P: 1m S: 3m M: 5m X□□: Custom Length R□□: Robot Cable	See Options below.		

\* See page Pre-47 for details on the model descriptions.



**For High Acceleration/Deceleration**

**Power-saving**

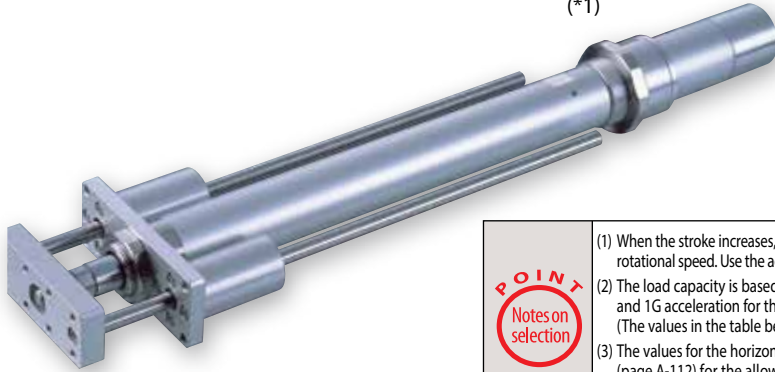

(\*1)

(\*1) Except all 20W models and 30W 3mm lead models

Technical References Appendix P.5



- (1) When the stroke increases, the maximum speed will drop to prevent the ball screw from reaching the critical rotational speed. Use the actuator specification table below to check the maximum speed at the stroke you desire.
- (2) The load capacity is based on operating the standard and power-saving models at 0.3G (0.2G for 3mm-lead), and 1G acceleration for the high-acceleration models (3mm-lead model excluded). (The values in the table below are the upper limits, even if the acceleration/deceleration is decreased.)
- (3) The values for the horizontal load capacity reflect the use of an external guide. See the technical resources (page A-112) for the allowable weight using the supplied guide alone.
- (4) See page A-71 for details on push motion.

### Actuator Specifications

#### Leads and Payloads

Model number	Motor output (W)	Lead (mm)	Max. Load Capacity		Rated thrust (N)	Stroke (mm)
			Horizontal (kg)	Vertical (kg)		
RCA-RGD4C-①-20-12-②-③-④-⑤	20	12	3.0	0.5	18.9	50~300 (every 50mm)
RCA-RGD4C-①-20-6-②-③-④-⑤		6	6.0	1.5	37.7	
RCA-RGD4C-①-20-3-②-③-④-⑤		3	12.0	3.5	75.4	
RCA-RGD4C-①-30-12-②-③-④-⑤	30	12	4.0	1.0	28.3	
RCA-RGD4C-①-30-6-②-③-④-⑤		6	9.0	2.5	56.6	
RCA-RGD4C-①-30-3-②-③-④-⑤		3	18.0	6.0	113.1	

#### Stroke and Maximum Speed

Stroke Lead	50~300 (every 50mm)
	12
6	300
3	150

(Unit: mm/s)

Code explanation ① Encoder ② Stroke ③ Applicable controller ④ Cable length ⑤ Options \*See page A-71 for details on push motion.

#### ① Encoder Type/② Stroke

② Stroke (mm)	Standard price			
	① Encoder Type			
	Incremental		Absolute	
	Motor Output (W)		Motor Output (W)	
	20W	30W	20W	30W
50	—	—	—	—
100	—	—	—	—
150	—	—	—	—
200	—	—	—	—
250	—	—	—	—
300	—	—	—	—

#### ④ Cable Length

Type	Cable symbol	Standard Price
Standard	P (1m)	—
	S (3m)	—
	M (5m)	—
Special length	X06 (6m) ~ X10 (10m)	—
	X11 (11m) ~ X15 (15m)	—
	X16 (16m) ~ X20 (20m)	—
Robot Cable	R01 (1m) ~ R03 (3m)	—
	R04 (4m) ~ R05 (5m)	—
	R06 (6m) ~ R10 (10m)	—
	R11 (11m) ~ R15 (15m)	—
	R16 (16m) ~ R20 (20m)	—

\* See page A-59 for cables for maintenance.

#### ⑤ Options

Name	Option code	See page	Standard price
Brake	B	→ A-42	—
Foot bracket	FT	→ A-49	—
High-acceleration/deceleration (*1)	HA	→ A-50	—
Home sensor (*2)	HS	→ A-50	—
Power-saving (*3)	LA	→ A-52	—
Non-motor end specification	NM	→ A-52	—
Trunnion bracket (back)	TRR	→ A-58	—

(\*1) The high-acceleration/deceleration option is not available for all 20W models and 30W model with 3mm lead.  
 (\*2) The home sensor (HS) cannot be used on the non-motor end models.  
 (\*3) The high-acceleration/deceleration option and the power-saving option cannot be used simultaneously.

#### Actuator Specifications

Item	Description
Drive System	Ball screw, ø10mm, rolled C10
Positioning Repeatability	±0.02mm
Lost Motion	0.1mm or less
Guide	Double guide (guide rod diameter ø10mm, Ball bush type)
Rod diameter	ø20mm
Non-rotating accuracy of rod	±0.05 deg
Ambient operating temperature, humidity	0 to 40°C, 85% RH or less (Non-condensing)

Dimensional Drawings

CAD drawings can be downloaded from the website. [www.intelligentactuator.com](http://www.intelligentactuator.com)



[No Brake]

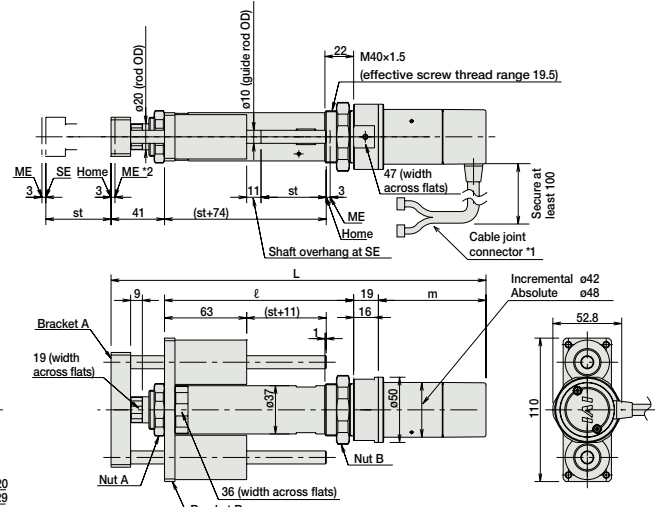

[Brake-Equipped]

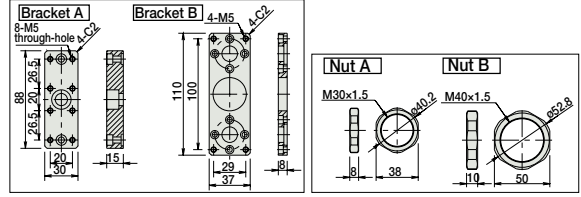
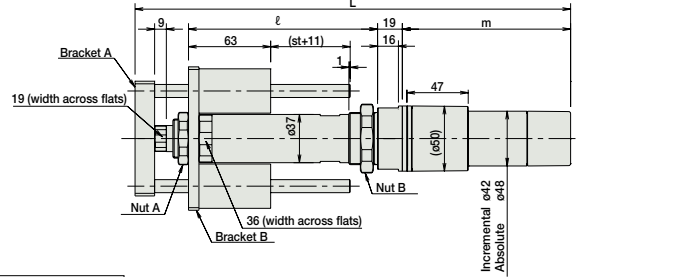

For Special Orders Appendix P.15

- (\*1) Connect the motor and encoder cables here. See page A-59 for details on cables.
  - (\*2) After homing, the slider moves to the ME, therefore, please watch for any interference with surrounding objects.
- ME : Mechanical end SE : Stroke end

■ Dimensions and Weight by Stroke  
RCA-RGD4C (without brake)

Stroke	RCA-RGD4C (without brake)							
	50	100	150	200	250	300		
L	20W	Increm.	272.5	322.5	372.5	422.5	472.5	522.5
		Absol.	285.5	335.5	385.5	435.5	485.5	535.5
	30W	Increm.	287.5	337.5	387.5	437.5	487.5	537.5
		Absol.	300.5	350.5	400.5	450.5	500.5	550.5
ℓ			145	195	245	295	345	395
m	20W	Increm.	67.5					
		Absol.	80.5					
	30W	Increm.	82.5					
		Absol.	95.5					
Weight (kg)			1.8	2.0	2.2	2.4	2.6	2.8

RCA-RGD4C (with brake)

Stroke	RCA-RGD4C (with brake)							
	50	100	150	200	250	300		
L	20W	Increm.	315.5	365.5	415.5	465.5	515.5	565.5
		Absol.	328.5	378.5	428.5	478.5	528.5	578.5
	30W	Increm.	330.5	380.5	430.5	480.5	530.5	580.5
		Absol.	343.5	393.5	443.5	493.5	543.5	593.5
ℓ			145	195	245	295	345	395
m	20W	Increm.	110.5					
		Absol.	123.5					
	30W	Increm.	125.5					
		Absol.	138.5					
Weight (kg)			2.0	2.2	2.4	2.6	2.8	3.0

③ Applicable Controllers

RCA series actuators can be operated with the controllers indicated below. Select the type according to your intended application. \* ACON-CY also can be used.

Name	External view	Model number	Features	Maximum number of positioning points	Input power	Power-supply capacity	Standard price	Reference page
Solenoid Valve Type		AMEC-C-20I(①)-(②)-2-1 AMEC-C-30I(①)-(②)-2-1	Easy-to-use controller, even for beginners	3 points	AC100V	2.4A rated	—	→ P537
		ASEP-C-20I(①)-(②)-2-0 ASEP-C-30I(①)-(②)-2-0	Simple controller operable with the same signal as a solenoid valve					→ P547
Solenoid valve multi-axis type PIO specification		MSEP-C-(④)-(⑤)-(⑥)-2-0	Positioner type based on PIO control, allowing up to 8 axes to be connected	256 points	DC24V	(Standard) 20W 1.3A rated 4.4A max. 30W 1.3A rated 4.4A max.	—	→ P563
Solenoid valve multi-axis type Network specification		MSEP-C-(④)-(⑤)-(⑥)-0-0	Field network-ready positioner type, allowing up to 8 axes to be connected					
Positioner type		ACON-C-20I(①)-(②)-2-0 ACON-C-30I(①)-(②)-2-0	Positioning is possible for up to 512 points	512 points	DC24V	(Power-saving) 20W 1.3A rated 2.5A max. 30W 1.3A rated 2.2A max.	—	→ P631
Safety-Compliant Positioner Type		ACON-CG-20I(①)-(②)-2-0 ACON-CG-30I(①)-(②)-2-0						
Pulse Train Input Type (Differential Line Driver)		ACON-PL-20I(①)-(②)-2-0 ACON-PL-30I(①)-(②)-2-0	Pulse train input type with differential line driver support	(—)	DC24V	(Power-saving) 20W 1.3A rated 2.5A max. 30W 1.3A rated 2.2A max.	—	→ P631
Pulse Train Input Type (Open Collector)		ACON-PO-20I(①)-(②)-2-0 ACON-PO-30I(①)-(②)-2-0	Pulse train input type with open collector support					
Serial Communication Type		ACON-SE-20I(①)-N-0-0 ACON-SE-30I(①)-N-0-0	Dedicated Serial Communication	64 points	DC24V	(Power-saving) 20W 1.3A rated 2.5A max. 30W 1.3A rated 2.2A max.	—	→ P675
Program Control Type		ASEL-CS-1-20I(①)-(②)-2-0 ASEL-CS-1-30I(①)-(②)-2-0	Programmed operation is possible. Can operate up to 2 axes	1,500 points	DC24V	(Power-saving) 20W 1.3A rated 2.5A max. 30W 1.3A rated 2.2A max.	—	→ P675

\* This is for the single-axis ASEL. \* ① indicates encoder type (I: incremental, A: absolute) \* Enter the code "HA" or "LA" in ① when the high-acceleration/deceleration option or the power-saving option is specified. \* ② indicates I/O type (NP/PN). \* ④ indicates number of axes (1 to 8). \* ⑤ indicates field network specification symbol.



- Slider Type
- Mini
- Standard
- Controller Integrated
- Rod Type
- Mini
- Standard
- Controllers Integrated
- Table/ Arm/ Flat Type
- Mini
- Standard
- Gripper/ Rotary Type
- Linear Servo Type
- Clean-room Type
- Splash-Proof Type
- Pulse Motor
- Servo Motor (24V)
- Servo Motor (200V)
- Linear Servo Motor



# RCA-RGD3D

Robo Cylinder, Rod Type with Double Guide, ø32mm Diameter, 24V Servo Motor, Built-In Model

Model Specification Items	<b>RCA</b>	<b>-RGD3D-</b>	<b>I</b>	<b>- 20</b>	<input type="checkbox"/>	<input type="checkbox"/>	<input type="checkbox"/>	<input type="checkbox"/>	<input type="checkbox"/>
Series	Type	Encoder type	Motor type	Lead	Stroke	Applicable controller	Cable length	Options	
		I: Incremental * The Simple absolute encoder is also considered type "I".	20: 20W Servo motor	10: 10mm 5: 5mm 2.5: 2.5mm	50: 50mm { 200: 200mm (50mm pitch increments)	A1: ACON ASEL A3: AMEC ASEP MSEP	N: None P: 1m S: 3m M: 5m X <input type="checkbox"/> : Custom Length R <input type="checkbox"/> : Robot Cable	See Options below.	

\* See page Pre-47 for details on the model descriptions.



Power-saving

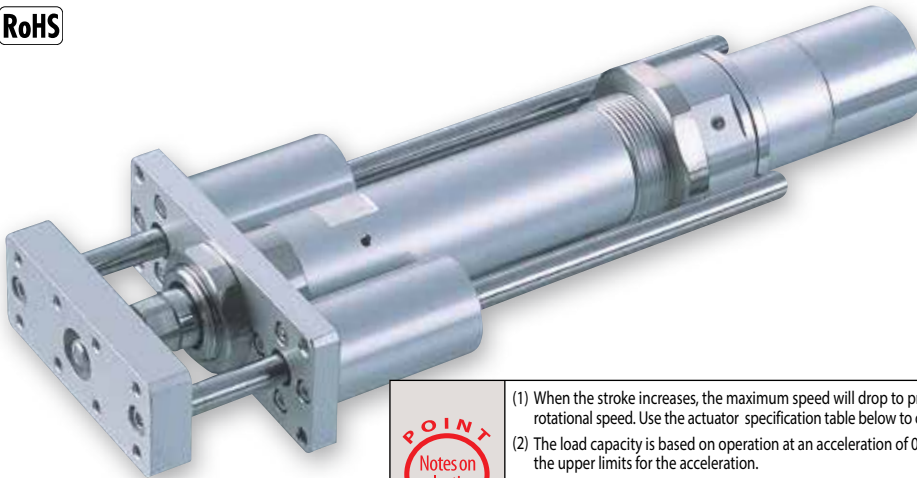

Technical References Appendix P.5



- When the stroke increases, the maximum speed will drop to prevent the ball screw from reaching the critical rotational speed. Use the actuator specification table below to check the maximum speed at the stroke you desire.
- The load capacity is based on operation at an acceleration of 0.3G (0.2G for 2.5mm-lead model). These values are the upper limits for the acceleration.
- The values for the horizontal load capacity reflect the use of an external guide. See the technical resources (page A-112) for the allowable weight using the supplied guide alone.
- See page A-71 for details on push motion.

## Actuator Specifications

### Leads and Payloads

Model number	Motor output (W)	Lead (mm)	Max. Load Capacity		Rated thrust (N)	Stroke (mm)
			Horizontal (kg)	Vertical (kg)		
RCA-RGD3D-I-20-10- <input type="checkbox"/> - <input type="checkbox"/> - <input type="checkbox"/> - <input type="checkbox"/>	20	10	4	1.2	36.2	50~200 (every 50mm)
RCA-RGD3D-I-20-5- <input type="checkbox"/> - <input type="checkbox"/> - <input type="checkbox"/> - <input type="checkbox"/>		5	9	2.7	72.4	
RCA-RGD3D-I-20-2.5- <input type="checkbox"/> - <input type="checkbox"/> - <input type="checkbox"/> - <input type="checkbox"/>		2.5	18	6.2	144.8	

### Stroke and Maximum Speed

Lead	Stroke	50~200 (every 50mm)
	10	500
5	250	250
2.5	125	125

Code explanation  Stroke  Applicable controller  Cable length  Options \*See page A-71 for details on push motion. (Unit: mm/s)

### ① Stroke

① Stroke (mm)	Standard price
50	—
100	—
150	—
200	—

### ③ Cable Length

Type	Cable symbol	Standard Price
Standard	P (1m)	—
	S (3m)	—
	M (5m)	—
Special length	X06 (6m) ~ X10 (10m)	—
	X11 (11m) ~ X15 (15m)	—
	X16 (16m) ~ X20 (20m)	—
Robot Cable	R01 (1m) ~ R03 (3m)	—
	R04 (4m) ~ R05 (5m)	—
	R06 (6m) ~ R10 (10m)	—
	R11 (11m) ~ R15 (15m)	—
	R16 (16m) ~ R20 (20m)	—

\* See page A-59 for cables for maintenance.

### ④ Options

Name	Option code	See page	Standard price
Foot bracket	FT	→ A-49	—
Home sensor	HS	→ A-50	—
Power-saving	LA	→ A-52	—
Non-motor end specification	NM	→ A-52	—
Trunnion bracket (back)	TRR	→ A-58	—

\*The home sensor (HS) cannot be used on the non-motor end models.

### Actuator Specifications

Item	Description
Drive System	Ball screw, ø8mm, rolled C10
Positioning Repeatability	±0.02mm
Lost Motion	0.1mm or less
Guide	Double guide (guide rod diameter ø8mm, Ball bush type)
Rod diameter	ø16mm
Non-rotating accuracy of rod	±0.05 deg
Ambient operating temperature, humidity	0 to 40°C, 85% RH or less (Non-condensing)

Dimensional Drawings

CAD drawings can be downloaded from the website. [www.intelligentactuator.com](http://www.intelligentactuator.com)

For Special Orders Appendix P.15



- (\*1) Connect the motor and encoder cables here. See page A-59 for details on cables.
  - (\*2) After homing, the slider moves to the ME, therefore, please watch for any interference with surrounding objects.
- ME : Mechanical end SE : Stroke end

[No Brake]

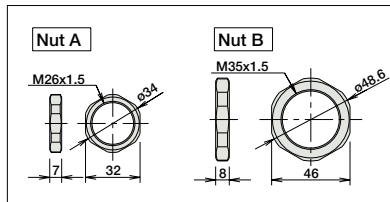
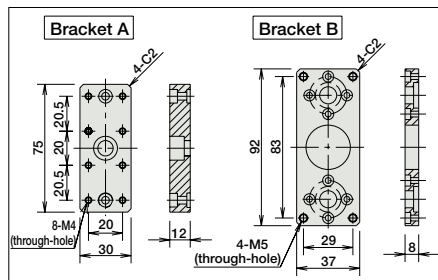
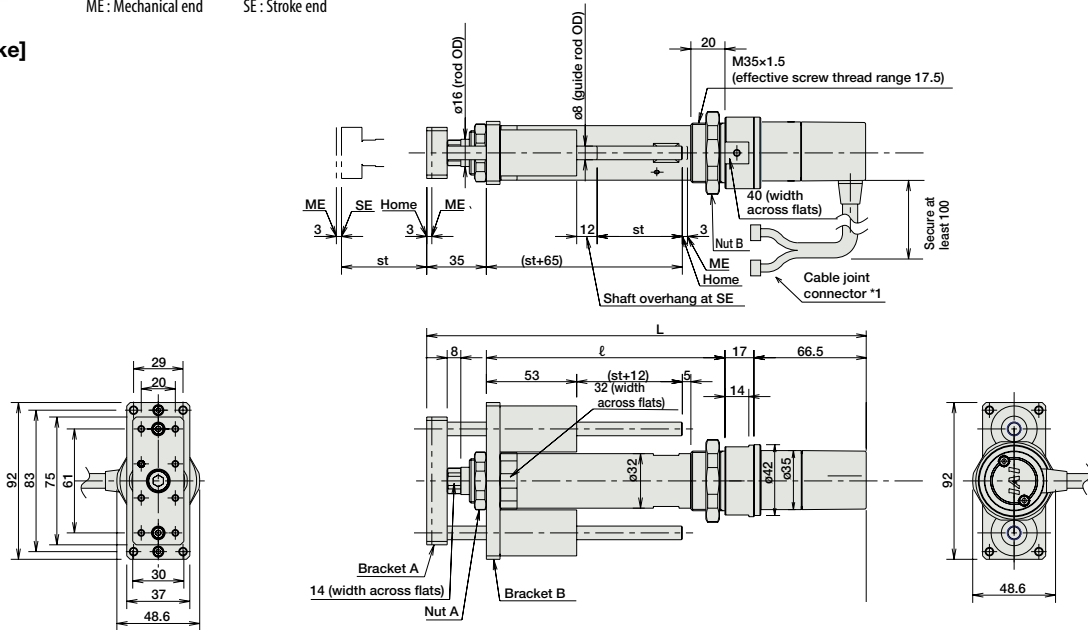

Dimensions and Weight by Stroke RCA-RGD3D (without brake)

Stroke	50	100	150	200
L	258.5	308.5	358.5	408.5
ℓ	140	190	240	290
Weight (kg)	1.1	1.2	1.4	1.5

RCA-RGD3D models are not equipped with a brake.

Applicable Controllers

RCA series actuators can be operated with the controllers indicated below. Select the type according to your intended application. \* ACON-CY also can be used.

Name	External view	Model number	Features	Maximum number of positioning points	Input power	Power-supply capacity	Standard price	Reference page
Solenoid Valve Type		AMEC-C-20SI①-②-2-1	Easy-to-use controller, even for beginners	3 points	AC100V	2.4A rated	—	→ P537
		ASEP-C-20SI①-②-2-0	Simple controller operable with the same signal as a solenoid valve					→ P547
Solenoid valve multi-axis type PIO specification		MSEP-C-③-④-⑤-2-0	Positioner type based on PIO control, allowing up to 8 axes to be connected	256 points	DC24V	(Standard) 1.7A rated 5.1A max.	—	→ P563
Solenoid valve multi-axis type Network specification		MSEP-C-③-④-⑤-0-0	Field network-ready positioner type, allowing up to 8 axes to be connected					
Positioner type		ACON-C-20SI①-②-2-0	Positioning is possible for up to 512 points	512 points	DC24V	(Power-saving) 1.7A rated 3.4A max.	—	→ P631
Safety-Compliant Positioner Type		ACON-CG-20SI①-②-2-0						
Pulse Train Input Type (Differential Line Driver)		ACON-PL-20SI①-②-2-0	Pulse train input type with differential line driver support	(—)	DC24V	(Power-saving) 1.7A rated 3.4A max.	—	→ P631
Pulse Train Input Type (Open Collector)		ACON-PO-20SI①-②-2-0	Pulse train input type with open collector support					
Serial Communication Type		ACON-SE-20SI①-N-0-0	Dedicated Serial Communication	64 points	DC24V	(Power-saving) 1.7A rated 3.4A max.	—	→ P675
Program Control Type		ASEL-CS-1-20SI①-②-2-0	Programmed operation is possible. Can operate up to 2 axes	1,500 points				

\* This is for the single-axis ASEL. \* Enter the code "LA" in ① when the power-saving specification is specified. \* ① indicates I/O type (NP/PN). \* ③ indicates number of axes (1 to 8). \* ④ indicates field network specification symbol.

# RCA-RGD4D

Robo Cylinder, Rod Type with Double Guide, ø37mm Diameter, 24V Servo Motor, Built-In Model

Model Specification Items	<b>RCA</b>	<b>— RGD4D</b>	<input type="checkbox"/>	<input type="checkbox"/>	<input type="checkbox"/>	<input type="checkbox"/>	<input type="checkbox"/>	<input type="checkbox"/>	<input type="checkbox"/>
	Series	Type	Encoder type	Motor type	Lead	Stroke	Applicable controller	Cable length	Options
	I: Incremental A: Absolute <small>* Absolute encoder models can only use ASEL. When the actuator is used with the simple absolute encoder, the model is considered an incremental model.</small>	20: 20W Servo motor 30: 30W Servo motor	12: 12mm 6: 6mm 3: 3mm	50: 50mm 300: 300mm (50mm pitch increments)	A1: ACON ASEL A3: AMEC ASEP MSEP	N: None P: 1m S: 3m M: 5m X <input type="checkbox"/> : Custom Length R <input type="checkbox"/> : Robot Cable	See Options below.		

\* See page Pre-47 for details on the model descriptions.

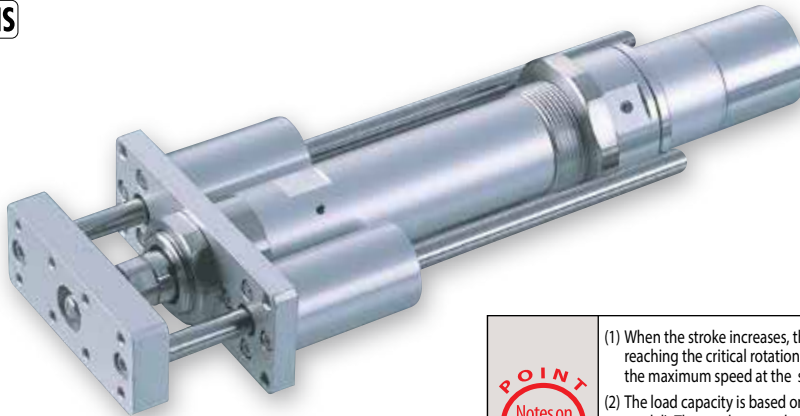

Power-saving

Technical References Appendix P.5

- POINT**  
Notes on selection
- (1) When the stroke increases, the maximum speed will drop to prevent the ball screw from reaching the critical rotational speed. Use the actuator specification table below to check the maximum speed at the stroke you desire.
  - (2) The load capacity is based on operation at an acceleration of 0.3G (0.2G for 3mm-lead model). These values are the upper limits for the acceleration.
  - (3) The values for the horizontal load capacity reflect the use of an external guide. See the technical resources (page A-112) for the allowable weight using the supplied guide alone.
  - (4) See page A-71 for details on push motion.

### Actuator Specifications

#### Leads and Payloads

Model number	Motor output (W)	Lead (mm)	Max. Load Capacity		Rated thrust (N)	Stroke (mm)
			Horizontal (kg)	Vertical (kg)		
RCA-RGD4D-①-20-12-②-③-④-⑤	20	12	3.0	0.5	18.9	50~300 (every 50mm)
RCA-RGD4D-①-20-6-②-③-④-⑤		6	6.0	1.5	37.7	
RCA-RGD4D-①-20-3-②-③-④-⑤		3	12.0	3.5	75.4	
RCA-RGD4D-①-30-12-②-③-④-⑤	30	12	4.0	1.0	28.3	
RCA-RGD4D-①-30-6-②-③-④-⑤		6	9.0	2.5	56.6	
RCA-RGD4D-①-30-3-②-③-④-⑤		3	18.0	6.0	113.1	

#### Stroke and Maximum Speed

Lead	Stroke	50~300 (every 50mm)
	50~300 (every 50mm)	
12	600	600
6	300	300
3	150	150

(Unit: mm/s)

Code explanation ① Encoder ② Stroke ③ Applicable controller ④ Cable length ⑤ Options \*See page A-71 for details on push motion.

#### ① Encoder Type/② Stroke

② Stroke (mm)	Standard price			
	① Encoder Type			
	Incremental		Absolute	
	Motor Output (W)		Motor Output (W)	
	20W	30W	20W	30W
50	—	—	—	—
100	—	—	—	—
150	—	—	—	—
200	—	—	—	—
250	—	—	—	—
300	—	—	—	—

#### ④ Cable Length

Type	Cable symbol	Standard Price
Standard	P (1m)	—
	S (3m)	—
	M (5m)	—
Special length	X06 (6m) ~ X10 (10m)	—
	X11 (11m) ~ X15 (15m)	—
	X16 (16m) ~ X20 (20m)	—
Robot Cable	R01 (1m) ~ R03 (3m)	—
	R04 (4m) ~ R05 (5m)	—
	R06 (6m) ~ R10 (10m)	—
	R11 (11m) ~ R15 (15m)	—
	R16 (16m) ~ R20 (20m)	—

\* See page A-59 for cables for maintenance.

#### ⑤ Options

Name	Option code	See page	Standard price
Foot bracket	FT	→ A-49	—
Home sensor	HS	→ A-50	—
Power-saving	LA	→ A-52	—
Non-motor end specification	NM	→ A-52	—
Trunnion bracket (back)	TRR	→ A-58	—

\*The home sensor (HS) cannot be used on the non-motor end models.

#### Actuator Specifications

Item	Description
Drive System	Ball screw, ø10mm, rolled C10
Positioning Repeatability	±0.02mm
Lost Motion	0.1mm or less
Guide	Double guide (guide rod diameter ø10mm, Ball bush type)
Rod diameter	ø20mm
Non-rotating accuracy of rod	±0.05 deg
Ambient operating temperature, humidity	0 to 40°C, 85% RH or less (Non-condensing)

Dimensional Drawings

CAD drawings can be downloaded from the website. [www.intelligentactuator.com](http://www.intelligentactuator.com)

For Special Orders Appendix P.15



- (\*1) Connect the motor and encoder cables here. See page A-59 for details on cables.
- (\*2) After homing, the slider moves to the ME, therefore, please watch for any interference with surrounding objects.

[No Brake]

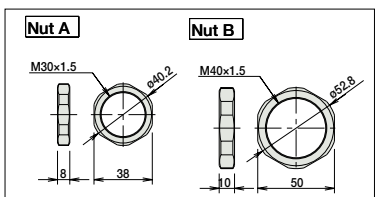
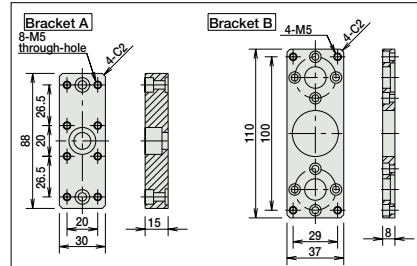
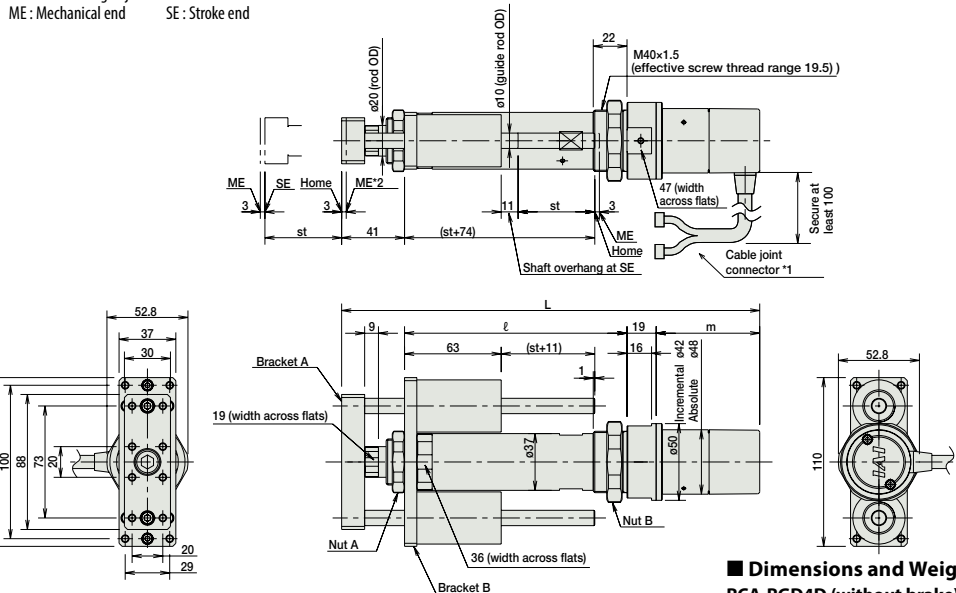

Dimensions and Weight by Stroke

		Stroke						
		50	100	150	200	250	300	
L	20W	Increment.	250.5	300.5	350.5	400.5	450.5	500.5
		Absol.	263.5	313.5	363.5	413.5	463.5	513.5
	30W	Increment.	265.5	315.5	365.5	415.5	465.5	515.5
		Absol.	278.5	328.5	378.5	428.5	478.5	528.5
		l	145	195	245	295	345	395
m	20W	Increment.	45.5					
		Absol.	58.5					
	30W	Increment.	60.5					
		Absol.	73.5					
		Weight (kg)	1.6	1.8	2.1	2.3	2.5	2.7

RCA-RGD4D models are not equipped with a brake.

Applicable Controllers

RCA series actuators can be operated with the controllers indicated below. Select the type according to your intended application. \* ACON-CY also can be used.

Name	External view	Model number	Features	Maximum number of positioning points	Input power	Power-supply capacity	Standard price	Reference page
Solenoid Valve Type		AMEC-C-20I(I)-(-)-2-1 AMEC-C-30I(I)-(-)-2-1	Easy-to-use controller, even for beginners	3 points	AC100V	2.4A rated	—	→ P537
		ASEP-C-20I(I)-(-)-2-0 ASEP-C-30I(I)-(-)-2-0	Simple controller operable with the same signal as a solenoid valve					
Solenoid valve multi-axis type PIO specification		MSEP-C-(V)~(-)-2-0	Positioner type based on PIO control, allowing up to 8 axes to be connected	256 points	DC24V	(Standard) 20W 1.3A rated 4.4A max. 30W 1.3A rated 4.4A max.	—	→ P563
Solenoid valve multi-axis type Network specification		MSEP-C-(V)~(-)-0-0	Field network-ready positioner type, allowing up to 8 axes to be connected					
Positioner type		ACON-C-20I(I)-(-)-2-0 ACON-C-30I(I)-(-)-2-0	Positioning is possible for up to 512 points	512 points	DC24V	(Power-saving) 20W 1.3A rated 2.5A max. 30W 1.3A rated 2.2A max.	—	→ P631
Safety-Compliant Positioner Type		ACON-CG-20I(I)-(-)-2-0 ACON-CG-30I(I)-(-)-2-0						
Pulse Train Input Type (Differential Line Driver)		ACON-PL-20I(I)-(-)-2-0 ACON-PL-30I(I)-(-)-2-0	Pulse train input type with differential line driver support	(—)	DC24V	(Power-saving) 20W 1.3A rated 2.5A max. 30W 1.3A rated 2.2A max.	—	→ P631
Pulse Train Input Type (Open Collector)		ACON-PO-20I(I)-(-)-2-0 ACON-PO-30I(I)-(-)-2-0	Pulse train input type with open collector support					
Serial Communication Type		ACON-SE-20I(I)-N-0-0 ACON-SE-30I(I)-N-0-0	Dedicated Serial Communication	64 points	DC24V	(Power-saving) 20W 1.3A rated 2.5A max. 30W 1.3A rated 2.2A max.	—	→ P675
Program Control Type		ASEL-CS-1-20I(I)-(-)-2-0 ASEL-CS-1-30I(I)-(-)-2-0	Programmed operation is possible. Can operate up to 2 axes	1,500 points	DC24V	(Power-saving) 20W 1.3A rated 2.5A max. 30W 1.3A rated 2.2A max.	—	→ P675

\* This is for the single-axis ASEL. \* (I) indicates encoder type (I: incremental, A: absolute) \* Enter the code "LA" in (I) when the power-saving specification is specified.  
 \* (II) indicates I/O type (NP/PN). \* (V) indicates number of axes (1 to 8). \* (V) indicates field network specification symbol.

# RCA-RGD3R

Robo Cylinder, Rod Type with Double Guide, ø32mm Diameter, 24V Servo Motor, Side-mounted Motor

Model Specification Items	<b>RCA</b> — <b>RGD3R</b> — <b>I</b> — <b>20</b> — <input type="checkbox"/> — <input type="checkbox"/> — <input type="checkbox"/> — <input type="checkbox"/> — <input type="checkbox"/>	Series	Type	Encoder type	Motor type	Lead	Stroke	Applicable controller	Cable length	Options
	I: Incremental * The Simple absolute encoder is also considered type "I".	20: 20W Servo motor	10: 10mm 5: 5mm 2.5: 2.5mm	50: 50mm { 200: 200mm (50mm pitch increments)	A1: ACON ASEL A3: AMEC ASEP MSEP	N: None P: 1m S: 3m M: 5m X <input type="checkbox"/> : Custom Length R <input type="checkbox"/> : Robot Cable	See Options below.			

\* See page Pre-47 for details on the model descriptions.



Power-saving

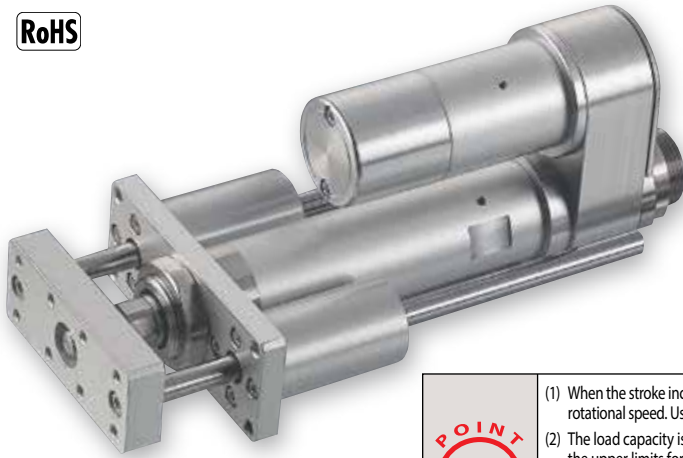

Technical References Appendix P.5



- (1) When the stroke increases, the maximum speed will drop to prevent the ball screw from reaching the critical rotational speed. Use the actuator specification table below to check the maximum speed at the stroke you desire.
- (2) The load capacity is based on operation at an acceleration of 0.3G (0.2G for 2.5mm-lead model). These values are the upper limits for the acceleration.
- (3) The values for the horizontal load capacity assume the use of an external guide, so that there is no external force from any direction other than the forward/backward direction of the rod. See the technical resources (page A-112) for the allowable weight using the supplied guide alone.
- (4) See page A-71 for details on push motion.

## Actuator Specifications

### Leads and Payloads

Model number	Motor output (W)	Lead (mm)	Max. Load Capacity		Rated thrust (N)	Stroke (mm)
			Horizontal (kg)	Vertical (kg)		
RCA-RGD3R-I-20-10- <input type="checkbox"/> - <input type="checkbox"/> - <input type="checkbox"/> - <input type="checkbox"/>	20	10	4.0	1.2	36.2	50~200 (every 50mm)
RCA-RGD3R-I-20-5- <input type="checkbox"/> - <input type="checkbox"/> - <input type="checkbox"/> - <input type="checkbox"/>		5	9.0	2.7	72.4	
RCA-RGD3R-I-20-2.5- <input type="checkbox"/> - <input type="checkbox"/> - <input type="checkbox"/> - <input type="checkbox"/>		2.5	18.0	6.2	144.8	

### Stroke and Maximum Speed

Stroke Lead	50~200 (every 50mm)	
	10	500
5	250	
2.5	125	

Code explanation  Stroke  Applicable controller  Cable length  Options \*See page A-71 for details on push motion. (Unit: mm/s)

### ① Stroke

① Stroke (mm)	Standard price
50	—
100	—
150	—
200	—

### ③ Cable Length

Type	Cable symbol	Standard Price
Standard	P (1m)	—
	S (3m)	—
	M (5m)	—
Special length	X06 (6m) ~ X10 (10m)	—
	X11 (11m) ~ X15 (15m)	—
	X16 (16m) ~ X20 (20m)	—
	R01 (1m) ~ R03 (3m)	—
Robot Cable	R04 (4m) ~ R05 (5m)	—
	R06 (6m) ~ R10 (10m)	—
	R11 (11m) ~ R15 (15m)	—
	R16 (16m) ~ R20 (20m)	—

\* See page A-59 for cables for maintenance.

### ④ Options

Name	Option code	See page	Standard price
Brake	B	→ A-42	—
Foot bracket	FT	→ A-49	—
Flange bracket (back)	FLR	→ A-46	—
Home sensor	HS	→ A-50	—
Power-saving	LA	→ A-52	—
Non-motor end specification	NM	→ A-52	—
Clevis bracket	QR	→ A-53	—
Back-mounting plate	RP	→ A-54	—

\*The home sensor (HS) cannot be used on the non-motor end models.

## Actuator Specifications

Item	Description
Drive System	Ball screw, ø8mm, rolled C10
Positioning Repeatability	±0.02mm
Lost Motion	0.1mm or less
Base	Material: Aluminum, white alumite treated
Rod diameter	ø16mm
Non-rotating accuracy of rod	±0.05 deg
Ambient operating temperature, humidity	0 to 40°C, 85% RH or less (Non-condensing)

Dimensional Drawings

CAD drawings can be downloaded from the website. [www.intelligentactuator.com](http://www.intelligentactuator.com)



For Special Orders Appendix P.15

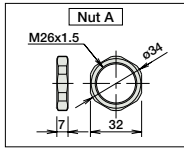

[No Brake]

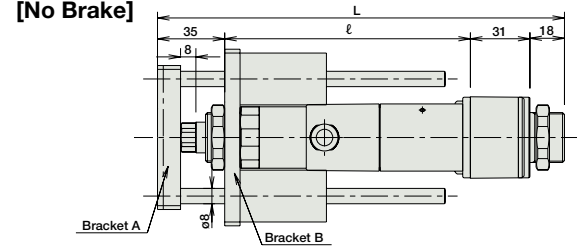

- (\*1) Connect the motor and encoder cables here. See page A-59 for details on cables.
- (\*2) After homing, the slider moves to the ME, therefore, please watch for any interference with surrounding objects.  
ME : Mechanical end SE : Stroke end
- (\*3) The orientation of the bolt varies depending on the product.

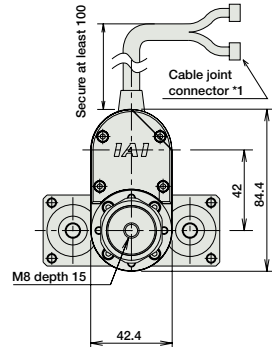
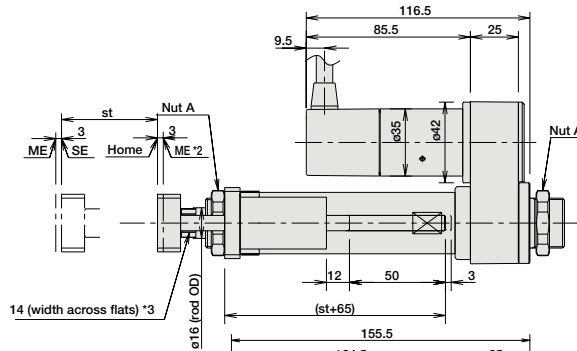
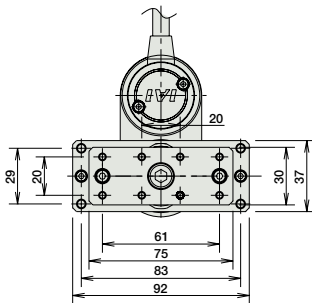

[Brake-Equipped]

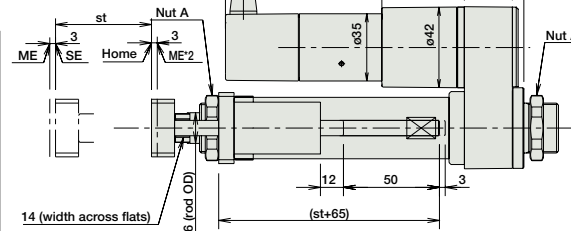
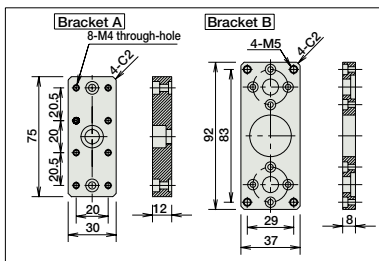

■ Dimensions and Weight by Stroke  
RCA-RGD3R (without brake)

Stroke	50	100	150	200
L	212	262	312	362
ℓ	128	178	228	278
Weight (kg)	1.2	1.3	1.5	1.6

RCA-RGD3R (with brake)

Stroke	50	100	150	200
L	212	262	312	362
ℓ	128	178	228	278
Weight (kg)	1.4	1.5	1.7	1.8

② Applicable Controllers

RCA series actuators can be operated with the controllers indicated below. Select the type according to your intended application. \* ACON-CY also can be used.

Name	External view	Model number	Features	Maximum number of positioning points	Input power	Power-supply capacity	Standard price	Reference page
Solenoid Valve Type		AMEC-C-20SI①-②-2-1	Easy-to-use controller, even for beginners	3 points	AC100V	2.4A rated	—	→ P537
		ASEP-C-20SI①-②-2-0	Simple controller operable with the same signal as a solenoid valve					→ P547
Solenoid valve multi-axis type PIO specification		MSEP-C-③-④-2-0	Positioner type based on PIO control, allowing up to 8 axes to be connected	256 points	DC24V	(Standard) 1.7A rated 5.1A max.	—	→ P563
Solenoid valve multi-axis type Network specification		MSEP-C-③-④-0-0	Field network-ready positioner type, allowing up to 8 axes to be connected					
Positioner type		ACON-C-20SI①-②-2-0	Positioning is possible for up to 512 points	512 points	DC24V	(Power-saving) 1.7A rated 3.4A max.	—	→ P631
Safety-Compliant Positioner Type		ACON-CG-20SI①-②-2-0						
Pulse Train Input Type (Differential Line Driver)		ACON-PL-20SI①-②-2-0	Pulse train input type with differential line driver support	(—)	DC24V	(Power-saving) 1.7A rated 3.4A max.	—	→ P631
Pulse Train Input Type (Open Collector)		ACON-PO-20SI①-②-2-0	Pulse train input type with open collector support					
Serial Communication Type		ACON-SE-20SI①-N-0-0	Dedicated Serial Communication	64 points	DC24V	(Power-saving) 1.7A rated 3.4A max.	—	→ P675
Program Control Type		ASEL-CS-1-20SI①-②-2-0	Programmed operation is possible. Can operate up to 2 axes	1,500 points	DC24V	(Power-saving) 1.7A rated 3.4A max.	—	→ P675

\* This is for the single-axis ASEL. \* Enter the code "LA" in ① when the power-saving specification is specified. \* ① indicates I/O type (NP/PN). \* ③ indicates number of axes (1 to 8). \* ④ indicates field network specification symbol.

- Slider Type
- Mini
- Standard
- Controller Integrated
- Rod Type
- Mini
- Standard
- Controllers Integrated
- Table/Arm/Flat Type
- Mini
- Standard
- Gripper/Rotary Type
- Linear Servo Type
- Clean-room Type
- Splash-Proof Type
- Pulse Motor
- Servo Motor (24V)
- Servo Motor (200V)
- Linear Servo Motor

# RCA-RGD4R

Robo Cylinder, Rod Type with Double Guide, Actuator Width 37mm, 24V Servo Motor, Side-mounted Motor

Model Specification Items	<b>RCA</b> — <b>RGD4R</b> —	— Encoder type —	— Motor type —	— Lead —	— Stroke —	— Applicable controller —	— Cable length —	— Options
	Series — Type	I: Incremental A: Absolute * Absolute encoder models can only use ASEL. When the actuator is used with the simple absolute encoder, the model is considered an incremental model.	20: 20W Servo motor 30: 30W Servo motor	12: 12mm 6: 6mm 3: 3mm	50: 50mm 300: 300mm (50mm pitch increments)	A1: ACON ASEL A3: AMEC ASEP MSEP	N: None P: 1m S: 3m M: 5m X□□: Custom Length R□□: Robot Cable	See Options below.

\* See page Pre-47 for details on the model descriptions.

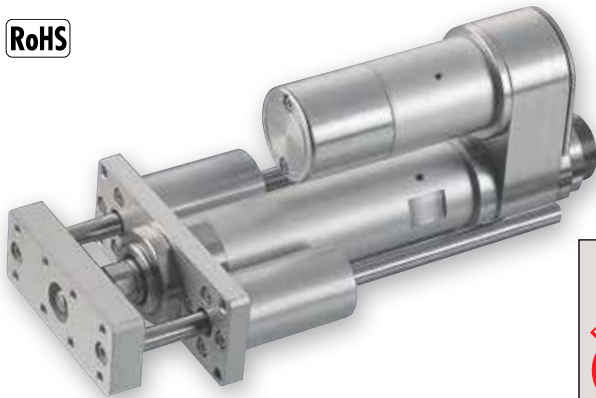

Power-saving

Technical References Appendix P.5

- POINT**  
Notes on selection
- (1) When the stroke increases, the maximum speed will drop to prevent the ball screw from reaching the critical rotational speed. Use the actuator specification table below to check the maximum speed at the stroke you desire.
  - (2) The load capacity is based on operation at an acceleration of 0.3G (0.2G for 3mm-lead model). These values are the upper limits for the acceleration.
  - (3) The values for the horizontal load capacity assume the use of an external guide, so that there is no external force from any direction other than the forward/backward direction of the rod. See the technical resources (page A-112) for the allowable weight using the supplied guide alone.
  - (4) See page A-71 for details on push motion.

### Actuator Specifications

#### Leads and Payloads

Model number	Motor output (W)	Lead (mm)	Max. Load Capacity		Rated thrust (N)	Stroke (mm)
			Horizontal (kg)	Vertical (kg)		
RCA-RGD4R-①-20-12-②-③-④-⑤	20	12	3.0	0.5	18.9	50~300 (every 50mm)
RCA-RGD4R-①-20-6-②-③-④-⑤		6	6.0	1.5	37.7	
RCA-RGD4R-①-20-3-②-③-④-⑤		3	12.0	3.5	75.4	
RCA-RGD4R-①-30-12-②-③-④-⑤	30	12	4.0	1.0	28.3	
RCA-RGD4R-①-30-6-②-③-④-⑤		6	9.0	2.5	56.6	
RCA-RGD4R-①-30-3-②-③-④-⑤		3	18.0	6.0	113.1	

#### Stroke and Maximum Speed

Stroke Lead	50~300 (every 50mm)	
	12	600
6	300	
3	150	

(Unit: mm/s)

Code explanation ① Encoder ② Stroke ③ Applicable controller ④ Cable length ⑤ Options \*See page A-71 for details on push motion.

#### ① Encoder Type/② Stroke

② Stroke (mm)	Standard price			
	① Encoder Type			
	Incremental		Absolute	
	Motor Output (W)		Motor Output (W)	
	20W	30W	20W	30W
50	—	—	—	—
100	—	—	—	—
150	—	—	—	—
200	—	—	—	—
250	—	—	—	—
300	—	—	—	—

#### ④ Cable Length

Type	Cable symbol	Standard Price
Standard	P (1m)	—
	S (3m)	—
	M (5m)	—
Special length	X06 (6m) ~ X10 (10m)	—
	X11 (11m) ~ X15 (15m)	—
	X16 (16m) ~ X20 (20m)	—
Robot Cable	R01 (1m) ~ R03 (3m)	—
	R04 (4m) ~ R05 (5m)	—
	R06 (6m) ~ R10 (10m)	—
	R11 (11m) ~ R15 (15m)	—
	R16 (16m) ~ R20 (20m)	—
	R16 (16m) ~ R20 (20m)	—

\* See page A-59 for cables for maintenance.

#### ⑤ Options

Name	Option code	See page	Standard price
Brake	B	→ A-42	—
Foot bracket	FT	→ A-49	—
Flange bracket (back)	FLR	→ A-46	—
Home sensor	HS	→ A-50	—
Power-saving	LA	→ A-52	—
Non-motor end specification	NM	→ A-52	—
Clevis bracket	QR	→ A-53	—
Back-mounting plate	RP	→ A-54	—

\*The home sensor (HS) cannot be used on the non-motor end models.

#### Actuator Specifications

Item	Description
Drive System	Ball screw, ø10mm, rolled C10
Positioning Repeatability	±0.02mm
Lost Motion	0.1mm or less
Base	Material: Aluminum, white alumite treated
Rod diameter	ø20mm
Non-rotating accuracy of rod	±0.05 deg
Ambient operating temperature, humidity	0 to 40°C, 85% RH or less (Non-condensing)

Dimensional Drawings

CAD drawings can be downloaded from the website. [www.intelligentactuator.com](http://www.intelligentactuator.com)



- (\*1) Connect the motor and encoder cables here. See page A-59 for details on cables.
- (\*2) After homing, the slider moves to the ME, therefore, please watch for any interference with surrounding objects.  
ME: Mechanical end SE: Stroke end
- (\*3) The orientation of the bolt varies depending on the product.

[No Brake]

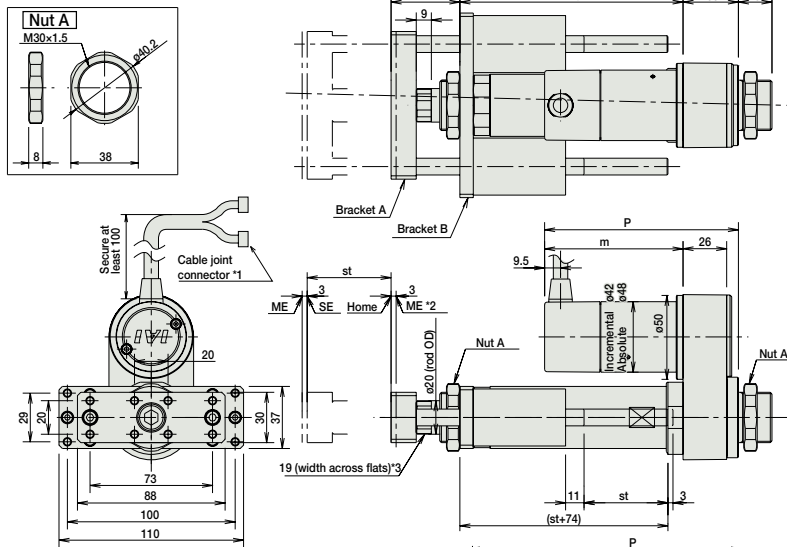

[Brake-Equipped]

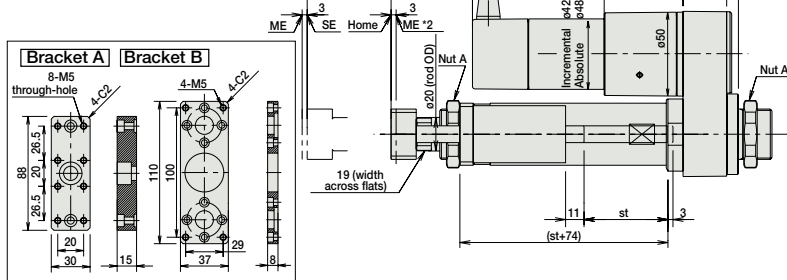

For Special Orders Appendix P.15

Dimensions and Weight by Stroke RCA-RGD4R (without brake)

L	Stroke	50	100	150	200	250	300	
		Increm.	227	277	327	377	427	477
	Absol.	227	277	327	377	427	477	
m	20W	Increm.	67.5					
		Absol.	80.5					
p	30W	Increm.	82.5					
		Absol.	95.5					
L <td rowspan="2">20W</td> <td>Increm.</td> <td colspan="5">100.5</td> <td></td>	20W	Increm.	100.5					
		Absol.	113.5					
m	30W	Increm.	115.5					
		Absol.	128.5					
Weight (kg)		1.9	2.2	2.3	2.6	2.7	3.0	

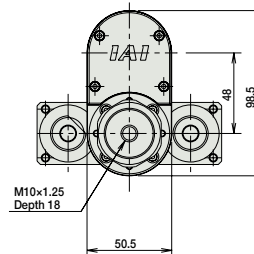

RCA-RGD4R (with brake)

L	Stroke	50	100	150	200	250	300	
		Increm.	227	277	327	377	427	477
	Absol.	227	277	327	377	427	477	
m	20W	Increm.	110.5					
		Absol.	123.5					
p	30W	Increm.	125.5					
		Absol.	138.5					
L <td rowspan="2">20W</td> <td>Increm.</td> <td colspan="5">143.5</td> <td></td>	20W	Increm.	143.5					
		Absol.	156.5					
m	30W	Increm.	158.5					
		Absol.	171.5					
Weight (kg)		2.1	2.4	2.5	2.8	2.9	3.2	

Applicable Controllers

RCA series actuators can be operated with the controllers indicated below. Select the type according to your intended application. \* ACON-CY also can be used.

Name	External view	Model number	Features	Maximum number of positioning points	Input power	Power-supply capacity	Standard price	Reference page
Solenoid Valve Type		AMEC-C-20I(①)-(②)-2-1 AMEC-C-30I(①)-(②)-2-1	Easy-to-use controller, even for beginners	3 points	AC100V	2.4A rated	—	→ P537
		ASEP-C-20I(①)-(②)-2-0 ASEP-C-30I(①)-(②)-2-0	Simple controller operable with the same signal as a solenoid valve					→ P547
Solenoid valve multi-axis type PIO specification		MSEP-C-(④)-(⑤)-(⑥)-2-0	Positioner type based on PIO control, allowing up to 8 axes to be connected	256 points	DC24V	(Standard) 20W 1.3A rated 4.4A max. 30W 1.3A rated 4.4A max.	—	→ P563
Solenoid valve multi-axis type Network specification		MSEP-C-(④)-(⑤)-(⑥)-0-0	Field network-ready positioner type, allowing up to 8 axes to be connected					→ P631
Positioner type		ACON-C-20I(①)-(②)-2-0 ACON-C-30I(①)-(②)-2-0	Positioning is possible for up to 512 points	512 points	DC24V	(Power-saving) 20W 1.3A rated 2.5A max. 30W 1.3A rated 2.2A max.	—	→ P631
Safety-Compliant Positioner Type		ACON-CG-20I(①)-(②)-2-0 ACON-CG-30I(①)-(②)-2-0						
Pulse Train Input Type (Differential Line Driver)		ACON-PL-20I(①)-(②)-2-0 ACON-PL-30I(①)-(②)-2-0	Pulse train input type with differential line driver support	(—)	DC24V	(Power-saving) 20W 1.3A rated 2.5A max. 30W 1.3A rated 2.2A max.	—	→ P631
Pulse Train Input Type (Open Collector)		ACON-PO-20I(①)-(②)-2-0 ACON-PO-30I(①)-(②)-2-0	Pulse train input type with open collector support					
Serial Communication Type		ACON-SE-20I(①)-N-0-0 ACON-SE-30I(①)-N-0-0	Dedicated Serial Communication	64 points	DC24V	(Power-saving) 20W 1.3A rated 2.5A max. 30W 1.3A rated 2.2A max.	—	→ P631
Program Control Type		ASEL-CS-1-20I(①)-(②)-2-0 ASEL-CS-1-30I(①)-(②)-2-0	Programmed operation is possible. Can operate up to 2 axes	1,500 points	DC24V	(Power-saving) 20W 1.3A rated 2.5A max. 30W 1.3A rated 2.2A max.	—	→ P675

\* This is for the single-axis ASEL. \* ① indicates encoder type (I: incremental, A: absolute) \* Enter the code "LA" in ① when the power-saving specification is specified.  
 \* ② indicates I/O type (NP/PN). \* ④ indicates number of axes (1 to 8). \* ⑤ indicates field network specification symbol.



# RCA-SRGD4R

Robo Cylinder, Rod Type with Double Guide, Actuator Width 45mm, Servo Motor, Short-Length Model

Model Specification Items	<b>RCA</b>	<b>—SRGD4R—</b>	<b>I</b>	<b>— 20</b>	<input type="checkbox"/>	<input type="checkbox"/>	<input type="checkbox"/>	<input type="checkbox"/>	<input type="checkbox"/>
	Series	Type	Encoder type	Motor type	Lead	Stroke	Applicable controller	Cable length	Options
			I: Incremental * The Simple absolute encoder is also considered type "I".	20: 20W Servo motor	5: 5mm 2.5: 2.5mm	20: 20mm 200: 200mm (10mm pitch increments) * Set in 50mm increments over 100mm	A1: ACON ASEL A3: AMEC ASEP MSEP	N: None P: 1m S: 3m M: 5m X□□: Custom Length	See Options below.

\* See page Pre-47 for details on the model descriptions.



Power-saving



Technical References Appendix P.5



- (1) The load capacity is based on operation at an acceleration of 0.3G (0.2G for the 2.5mm-lead model, or when used vertically). This is the upper limit of the acceleration.
- (2) The values for the horizontal load capacity reflect the use of an external guide. See the technical resources (page A-112) for the allowable weight using the supplied guide alone.
- (3) See page A-71 for details on push motion.

## Actuator Specifications

### Leads and Payloads

(Note A) 50mm increments over 100mm.

Model number	Motor output (W)	Lead (mm)	Max. Load Capacity		Rated thrust (N)	Stroke (mm)
			Horizontal (kg)	Vertical (kg)		
RCA-SRGD4R-I-20-5-①-②-③-④	20	5	9 (Note1)	2	41	20~200 (every 10mm) (Note A)
RCA-SRGD4R-I-20-2.5-①-②-③-④		2.5	18 (Note1)	5.5	81	

### Stroke and Maximum Speed

Lead	Stroke	20~200 (every 10mm)
	5	
2.5		125

Code explanation ① Stroke ② Applicable controller ③ Cable length ④ Options \*See page A-71 for details on push motion. (Unit: mm/s)

### ① Stroke

① Stroke (mm)	Standard price
20~50	—
60~100	—
150	—
200	—

### ③ Cable Length

Type	Cable symbol	Standard Price
Standard (Robot Cables)	P (1m)	—
	S (3m)	—
	M (5m)	—
Special length	X06 (6m) ~ X10 (10m)	—
	X11 (11m) ~ X15 (15m)	—
	X16 (16m) ~ X20 (20m)	—
		—

\* The standard cable is the motor-encoder integrated robot cable.  
\* See page A-59 for cables for maintenance.

### ④ Options

Name	Option code	See page	Standard price
Brake	B	→ A-42	—
Flange bracket (back)	FLR	→ A-46	—
Power-saving	LA	→ A-52	—
Non-motor end specification	NM	→ A-52	—

\* The brake is available for strokes of 70mm or more.

### Actuator Specifications

Item	Description
Drive System	Ball screw, ø8mm, rolled C10
Positioning Repeatability	±0.02mm
Lost Motion	0.1mm or less
Rod diameter	ø22mm
Non-rotating accuracy of rod	±0.05 deg
Ambient operating temperature, humidity	0 to 40°C, 85% RH or less (Non-condensing)

Dimensional Drawings

CAD drawings can be downloaded from the website. [www.intelligentactuator.com](http://www.intelligentactuator.com)

For Special Orders Appendix P.15

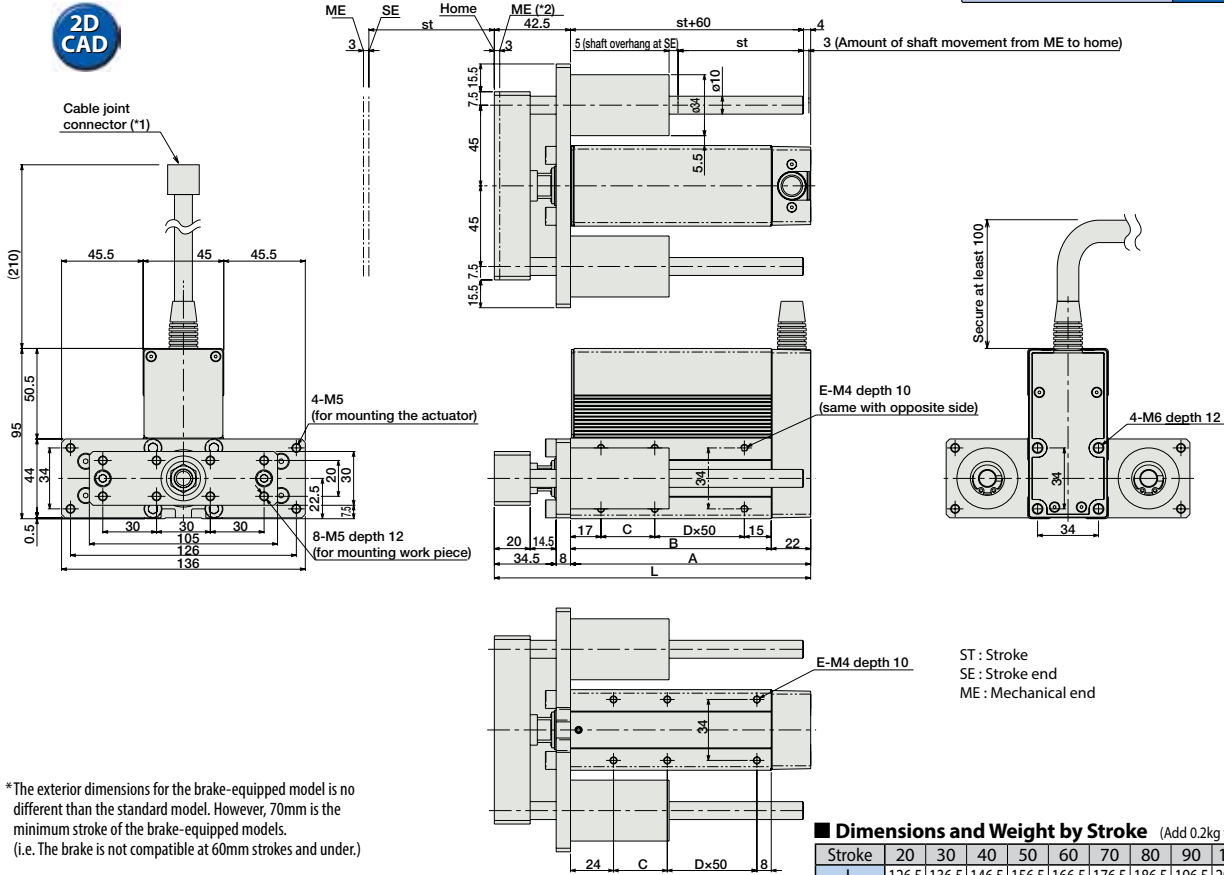

\*The exterior dimensions for the brake-equipped model is no different than the standard model. However, 70mm is the minimum stroke of the brake-equipped models. (i.e. The brake is not compatible at 60mm strokes and under.)

(\*1) Connect the motor-encoder integrated cable here. See page A-59 for details on cables.  
(\*2) After homing, the slider moves to the ME, therefore, please watch for any interference with surrounding objects.

**■ Dimensions and Weight by Stroke** (Add 0.2kg for brake equipped)

Stroke	20	30	40	50	60	70	80	90	100	150	200
L	126.5	136.5	146.5	156.5	166.5	176.5	186.5	196.5	206.5	256.5	306.5
A	84	94	104	114	124	134	144	154	164	214	264
B	62	72	82	92	102	112	122	132	142	192	242
C	30	40	50	60	70	30	40	50	60	60	60
D	0	0	0	0	0	1	1	1	1	2	3
E	4	4	4	4	4	6	6	6	6	8	10
Weight (kg)	1.42	1.49	1.56	1.64	1.71	1.79	1.86	1.94	2.01	2.38	2.75

② Applicable Controllers

RCA series actuators can be operated with the controllers indicated below. Select the type according to your intended application. \* ACON-CY also can be used.

Name	External view	Model number	Features	Maximum number of positioning points	Input power	Power-supply capacity	Standard price	Reference page
Solenoid Valve Type		AMEC-C-20I①-②-2-1	Easy-to-use controller, even for beginners	3 points	AC100V	2.4A rated	—	→ P537
		ASEP-C-20I①-②-2-0	Simple controller operable with the same signal as a solenoid valve					→ P547
Solenoid valve multi-axis type PIO specification		MSEP-C-③-④-2-0	Positioner type based on PIO control, allowing up to 8 axes to be connected	256 points	DC24V	(Standard) 1.3A rated 4.4A max. (Power-saving) 1.3A rated 2.5A max.	—	→ P563
Solenoid valve multi-axis type Network specification		MSEP-C-③-④-0-0	Field network-ready positioner type, allowing up to 8 axes to be connected					
Positioner type		ACON-C-20I①-②-2-0	Positioning is possible for up to 512 points	512 points	DC24V	(Standard) 1.3A rated 4.4A max. (Power-saving) 1.3A rated 2.5A max.	—	—
Safety-Compliant Positioner Type		ACON-CG-20I①-②-2-0						
Pulse Train Input Type (Differential Line Driver)		ACON-PL-20I①-②-2-0	Pulse train input type with differential line driver support	(—)	DC24V	(Standard) 1.3A rated 4.4A max. (Power-saving) 1.3A rated 2.5A max.	—	→ P631
Pulse Train Input Type (Open Collector)		ACON-PO-20I①-②-2-0	Pulse train input type with open collector support					
Serial Communication Type		ACON-SE-20I①-N-0-0	Dedicated Serial Communication	64 points	DC24V	(Standard) 1.3A rated 4.4A max. (Power-saving) 1.3A rated 2.5A max.	—	—
Program Control Type		ASEL-CS-1-20I①-②-2-0	Programmed operation is possible. Can operate up to 2 axes	1,500 points	DC24V	(Standard) 1.3A rated 4.4A max. (Power-saving) 1.3A rated 2.5A max.	—	→ P675

\* This is for the single-axis ASEL. \* Enter the code "LA" in ① when the power-saving specification is specified. \* ③ indicates I/O type (NP/PN).  
\* ④ indicates number of axes (1 to 8). \* ⑤ indicates field network specification symbol.

- Slider Type
- Mini
- Standard
- Controller Integrated
- Rod Type
- Mini
- Standard
- Controllers Integrated
- Table/Arm/Flat Type
- Mini
- Standard
- Gripper/Rotary Type
- Linear Servo Type
- Clean-room Type
- Splash-Proof Type
- Pulse Motor
- Servo Motor (24V)
- Servo Motor (200V)
- Linear Servo Motor

# RCS2-RN5N

Robo Cylinder, Mini Rod Type, Short-Length Tapped-Hole Mounting Type, Actuator Width 46mm, 200V Servo Motor, Ball Screw Specification

Model Specification Items	<b>RCS2</b>	<b>— RN5N</b>	<b>— I</b>	<b>— 60</b>	<input type="checkbox"/>	<input type="checkbox"/>	<b>T2</b>	<input type="checkbox"/>	<input type="checkbox"/>
	Series	Type	Encoder type	Motor type	Lead	Stroke	Applicable controller	Cable length	Options
			I: Incremental specification	60: 60W Servo motor	10: 10mm 5: 5mm 2.5: 2.5mm	50: 50mm 75: 75mm	T2: SCON-CA SSEL XSEL-P/Q	N: None P: 1m S: 3m M: 5m X <input type="checkbox"/> : Custom Length R <input type="checkbox"/> : Robot Cable	See options below.

\* See page Pre-47 for details on the model descriptions.



\*CE compliance is optional.

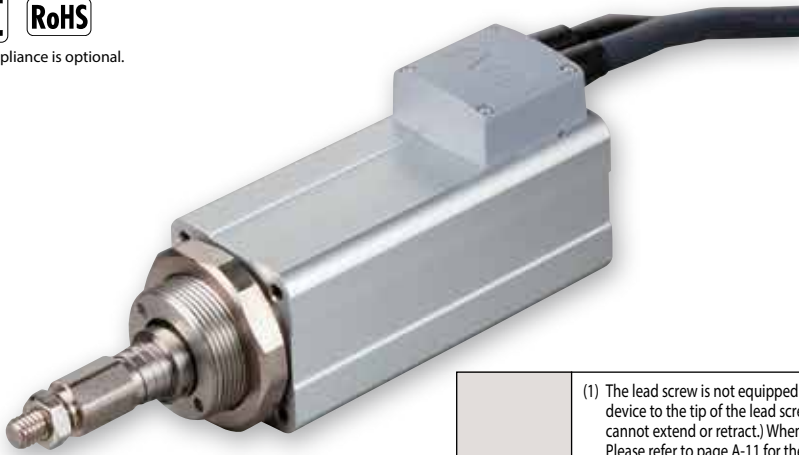

Technical References Appendix P.5



- The lead screw is not equipped with an anti-rotation device, so please attach a guide or similar locking device to the tip of the lead screw prior to use. (If there is no anti-rotation device attached, the lead screw cannot extend or retract.) When connecting the anti-rotation device and rod, do not use a floating joint. Please refer to page A-11 for the instruction details.
- The horizontal payload is the value when the actuator uses an external guide.
- The payload is the value when the actuator is operated at an acceleration of 0.3 G (0.2G for 2.5mm-lead) horizontally and 0.2G vertically. The acceleration limit is the value indicated above.
- Do not apply an external force on the rod in any direction other than the direction the rod is moving in.
- If the actuator is used vertically, pay attention to rod contact because the rod will come down when the power is turned off.
- See page A-71 for details on push motion.

### Actuator Specifications

#### Leads and Payloads

Model number	Motor output (W)	Feed screw	Lead (mm)	Max. Load Capacity Horizontal (kg) Vertical (kg)	Rated thrust (N)	Positioning Repeatability (mm)	Stroke (mm)
RCS2-RN5N-I-60-10-①-T2-②-③	60	Ball screw	10	5 1.5	89	±0.02	50 75
RCS2-RN5N-I-60-5-①-T2-②-③			5	10 3	178		
RCS2-RN5N-I-60-2.5-①-T2-②-③			2.5	20 6	356		

Code explanation ① Stroke ② Cable length ③ Options \*See page A-71 for details on push motion.

#### Stroke and Maximum Speed

Stroke / Lead	50 (mm)	75 (mm)
10	280 <230>	380 <330>
5	250 <230>	250
2.5	125	

\* The values enclosed in < > apply to vertical settings. (Unit: mm/s)

#### ① Stroke

Stroke (mm)	Standard price
50	—
75	—

#### ② Cable Length

Type	Cable symbol	Standard Price
Standard	P (1m)	—
	S (3m)	—
	M (5m)	—
Special length	X06 (6m) ~ X10 (10m)	—
	X11 (11m) ~ X15 (15m)	—
	X16 (16m) ~ X20 (20m)	—
Robot Cable	R01 (1m) ~ R03 (3m)	—
	R04 (4m) ~ R05 (5m)	—
	R06 (6m) ~ R10 (10m)	—
	R11 (11m) ~ R15 (15m)	—
	R16 (16m) ~ R20 (20m)	—

\* See page A-59 for cables for maintenance.

#### ③ Options

Name	Option code	See page	Standard price
Brake	B	→ A-42	—
CE compliance	CE	→ A-42	—
Connector cable exits (left)	K1	→ A-51	—
Connector cable exits (front)	K2	→ A-51	—
Connector cable exits (right)	K3	→ A-51	—

#### Actuator Specifications

Item	Description
Drive System	Ball screw, ø8mm, rolled C10
Lost Motion	0.1mm or less
Frame	Material: Aluminum, white alumite treated
Ambient operating temperature, humidity	0 to 40°C, 85% RH or less (Non-condensing)
Service life	5,000km or 50 million cycles

259 RCS2-RN5N

## Dimensional Drawings

CAD drawings can be downloaded from the website.

[www.intelligentactuator.com](http://www.intelligentactuator.com)

For Special Orders

Appendix P.15



- (\*1) Connect the motor and encoder cables here. See page A-59 for details on cables.
- (\*2) After homing, the slider moves to the ME, therefore, please watch for any interference with surrounding objects.  
ME : Mechanical end SE : Stroke end
- (\*3) The orientation of the nut varies depending on the product.

Note:  
This product doesn't come with the screw stopper. Please add a stopper before use.

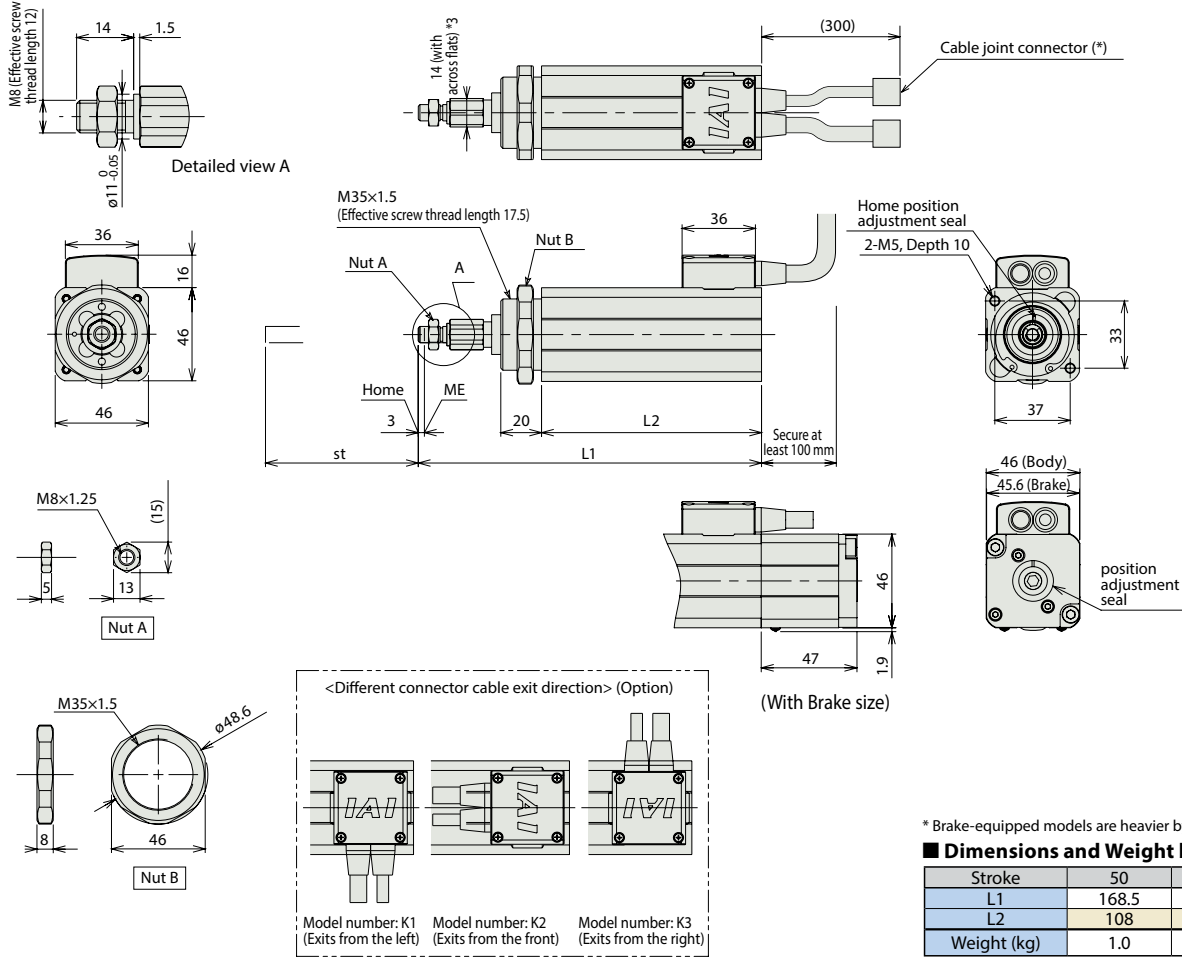

\* Brake-equipped models are heavier by 0.26kg.

### Dimensions and Weight by Stroke

Stroke	50	75
L1	168.5	193.5
L2	108	133
Weight (kg)	1.0	1.1

### Applicable Controllers

RCS2 series actuators can be operated with the controllers indicated below. Select the type according to your intended application.

Name	External view	Model number	Features	Maximum number of positioning points	Input power	Power-supply capacity	Standard price	Reference page
Positioner Type		SCON-CA-60I-NP-2-①	Up to 512 positioning points are supported	512 points	Single-phase 100 VAC	218 VA max.	—	→ P643
Solenoid mode			Can be operated with the same controls used for solenoid valves	7 points				
Network mode			Can be moved by direct numerical specification	768 points				
Pulse-train input control mode			Can be controlled using pulse trains	(—)	Single-phase 200 VAC	—		
Program control type 1 or 2 axes		SSEL-CS-1-60I-NP-2-①	Program operation is supported Up to two axes can be operated	20,000 points	3-phase 200 VAC (XSEL-P/Q only)	—	—	→ P685
Program control type 1 or 6 axes		XSEL-①-1-60I-N1-EEE-2-3	Program operation is supported Up to six axes can be operated	20,000 points				—

\* The values of SSEL and XSEL assume a 1-axis specification. \* ① indicates the type of power-supply voltage (1: 100 V/2: Single-phase 200 V). \* ①① indicates the XSEL type (P/Q).

Please note that this model cannot be connected to the XSEL-R/P/Q type (5-axis/6-axis), XSEL-R/S type, or MSCON.

# RCS2-RP5N

Robo Cylinder, Mini Rod Type, Short-Length Tapped-Hole Mounting Type, Actuator Width 46mm, 200V Servo Motor, Ball Screw Specification

Model Specification Items	<b>RCS2</b> — <b>RP5N</b> — <b>I</b> — <b>60</b> — <input type="checkbox"/> — <input type="checkbox"/> — <b>T2</b> — <input type="checkbox"/> — <input type="checkbox"/>
	Series — Type — Encoder type — Motor type — Lead — Stroke — Applicable controller — Cable length — Options
	I: Incremental specification 60: 60W Servo motor 10: 10mm 5: 5mm 2.5: 2.5mm T2: SCON-CA SSEL XSEL-P/Q N: None P: 1m S: 3m M: 5m X <input type="checkbox"/> : Custom Length R <input type="checkbox"/> : Robot Cable

\* See page Pre-47 for details on the model descriptions.



\*CE compliance is optional.



Technical References Appendix P.5



- The lead screw is not equipped with an anti-rotation device, so please attach a guide or similar locking device to the tip of the lead screw prior to use. (If there is no anti-rotation device attached, the lead screw cannot extend or retract.) When connecting the anti-rotation device and rod, do not use a floating joint. Please refer to page A-11 for the instruction details.
- The horizontal payload is the value when the actuator uses an external guide.
- The payload is the value when the actuator is operated at an acceleration of 0.3 G (0.2G for 2.5mm-lead) horizontally and 0.2G vertically. The acceleration limit is the value indicated above.
- Do not apply an external force on the rod in any direction other than the direction the rod is moving in.
- If the actuator is used vertically, pay attention to rod contact because the rod will come down when the power is turned off.
- See page A-71 for details on push motion.

### Actuator Specifications

#### Leads and Payloads

Model number	Motor output (W)	Feed screw	Lead (mm)	Max. Load Capacity		Rated thrust (N)	Positioning Repeatability (mm)	Stroke (mm)
				Horizontal (kg)	Vertical (kg)			
RCS2-RP5N-I-60-10-①-T2-②-③	60	Ball screw	10	5	1.5	89	±0.02	50 75
RCS2-RP5N-I-60-5-①-T2-②-③			5	10	3	178		
RCS2-RP5N-I-60-2.5-①-T2-②-③			2.5	20	6	356		

#### Stroke and Maximum Speed

Stroke Lead	50 (mm)	75 (mm)
	10	280 <230>
5	250 <230>	250
2.5	125	

Code explanation ① Stroke ② Cable length ③ Options \*See page A-71 for details on push motion.

\* The values enclosed in < > apply to vertical settings. (Unit: mm/s)

#### ① Stroke

Stroke (mm)	Standard price
50	—
75	—

#### ② Cable Length

Type	Cable symbol	Standard Price
Standard	P (1m)	—
	S (3m)	—
	M (5m)	—
Special length	X06 (6m) ~ X10 (10m)	—
	X11 (11m) ~ X15 (15m)	—
	X16 (16m) ~ X20 (20m)	—
Robot Cable	R01 (1m) ~ R03 (3m)	—
	R04 (4m) ~ R05 (5m)	—
	R06 (6m) ~ R10 (10m)	—
	R11 (11m) ~ R15 (15m)	—
	R16 (16m) ~ R20 (20m)	—

\* See page A-59 for cables for maintenance.

#### ③ Options

Name	Option code	See page	Standard price
Brake	B	→ A-42	—
CE compliance	CE	→ A-42	—
Connector cable exits (left)	K1	→ A-51	—
Connector cable exits (front)	K2	→ A-51	—
Connector cable exits (right)	K3	→ A-51	—

#### Actuator Specifications

Item	Description
Drive System	Ball screw, Ø8mm, rolled C10
Lost Motion	0.1mm or less
Frame	Material: Aluminum, white alumite treated
Ambient operating temperature, humidity	0 to 40°C, 85% RH or less (Non-condensing)
Service life	5,000km or 50 million cycles

## Dimensional Drawings

CAD drawings can be downloaded from the website. [www.intelligentactuator.com](http://www.intelligentactuator.com)

For Special Orders Appendix P.15



- (\*1) Connect the motor and encoder cables here. See page A-59 for details on cables.
- (\*2) After homing, the slider moves to the ME, therefore, please watch for any interference with surrounding objects.  
ME : Mechanical end SE : Stroke end
- (\*3) The orientation of the nut varies depending on the product.

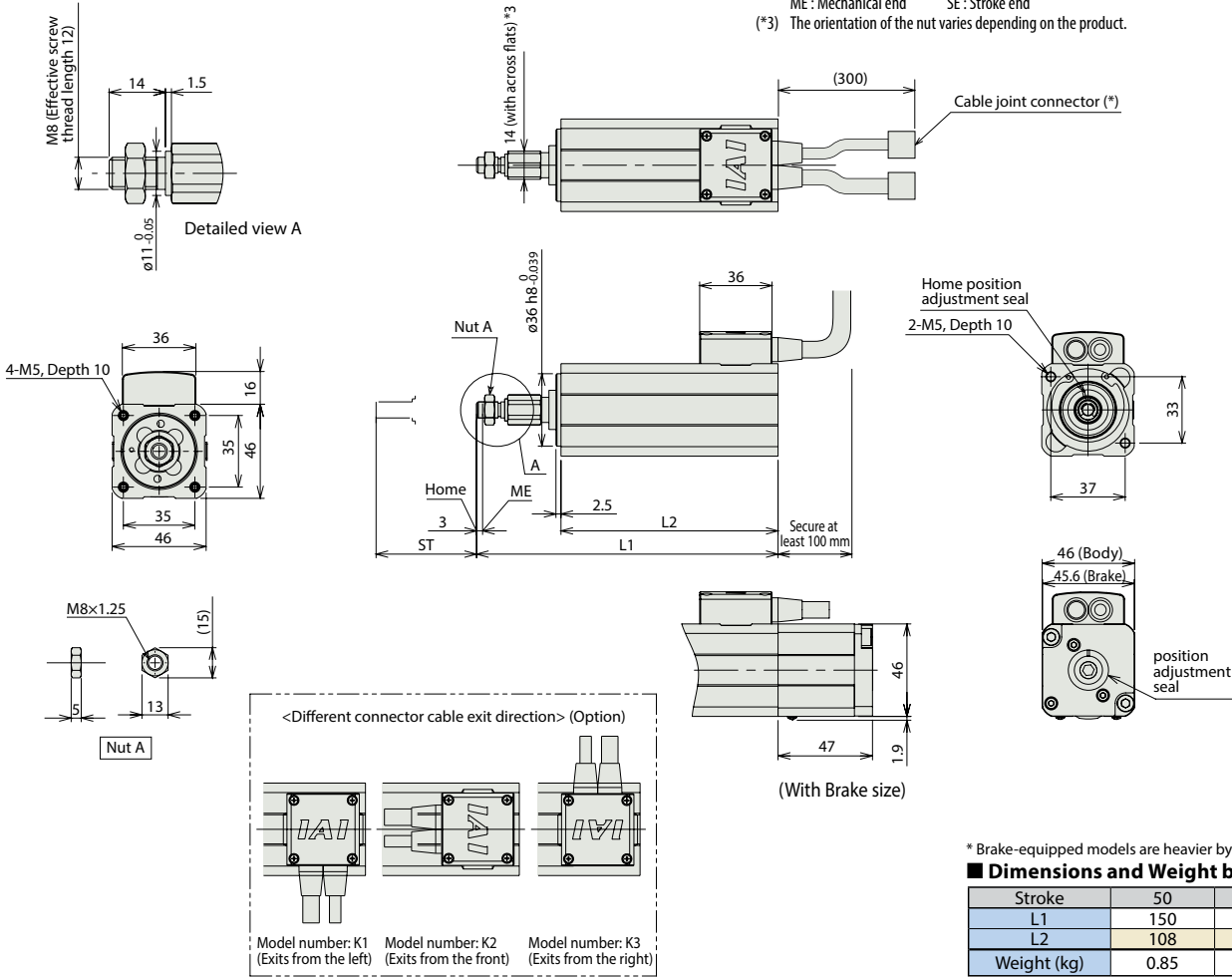

\* Brake-equipped models are heavier by 0.26kg.

■ Dimensions and Weight by Stroke		
Stroke	50	75
L1	150	175
L2	108	133
Weight (kg)	0.85	1.0

## Applicable Controllers

RCS2 series actuators can be operated with the controllers indicated below. Select the type according to your intended application.

Name	External view	Model number	Features	Maximum number of positioning points	Input power	Power-supply capacity	Standard price	Reference page
Positioner Type		SCON-CA-60I-NP-2-①	Up to 512 positioning points are supported	512 points	Single-phase 100 VAC	218 VA max.	—	→ P643
Solenoid mode			Can be operated with the same controls used for solenoid valves	7 points				
Network mode			Can be moved by direct numerical specification	768 points				
Pulse-train input control mode			Can be controlled using pulse trains	(—)	Single-phase 200 VAC	—		
Program control type 1 or 2 axes		SSEL-CS-1-60I-NP-2-①	Program operation is supported Up to two axes can be operated	20,000 points	3-phase 200 VAC (XSEL-P/Q only)	* Varies depending on the controller. Refer to the operation manual for details.	—	→ P685
Program control type 1 or 6 axes		XSEL-①-1-60I-N1-EEE-2-3	Program operation is supported Up to six axes can be operated	20,000 points			—	→ P695

\* The values of SSEL and XSEL assume a 1-axis specification. \* ① indicates the type of power-supply voltage (1: 100 V/2: Single-phase 200 V). \* ① indicates the XSEL type (P/Q).

Please note that this model cannot be connected to the XSEL-P/Q type (5-axis/6-axis), XSEL-R/S type, or MSCON.

# RCS2-GS5N

Robo Cylinder, Mini Rod Type, Short-Length Single-Guide Type, Actuator Width 46mm, 200V Servo Motor, Ball Screw Specification

Model Specification Items	<b>RCS2</b>	<b>GS5N</b>	<b>I</b>	<b>60</b>	<input type="checkbox"/>	<input type="checkbox"/>	<b>T2</b>	<input type="checkbox"/>	<input type="checkbox"/>
	Series	Type	Encoder type	Motor type	Lead	Stroke	Applicable controller	Cable length	Options
			I: Incremental specification	60: 60W Servo motor	10: 10mm 5: 5mm 2.5: 2.5mm	50: 50mm 75: 75mm	T2: SCON-CA SSEL XSEL-P/Q	N: None P: 1m S: 3m M: 5m X <input type="checkbox"/> : Custom Length R <input type="checkbox"/> : Robot Cable	See options below.

\* See page Pre-47 for details on the model descriptions.



\*CE compliance is optional.



Technical References Appendix P.5



- (1) The horizontal payload is the value when used in combination with a guide so that a radial load and moment load are not applied to the rod. See page A-110 for correlation diagrams of the end load and service life when a guide is not installed. Also note that single-guide types cannot be used if a force is applied in the rotating direction. Use double-guide types in these applications.
- (2) The payload is the value when the actuator is operated at an acceleration of 0.3 G (0.2G for 2.5mm-lead) horizontally and 0.2G vertically. The acceleration limit is the value indicated above.
- (3) If the actuator is used vertically, pay attention to rod contact because the rod will come down when the power is turned off.
- (4) See page A-71 for details on push motion.

### Actuator Specifications

#### Leads and Payloads

Model number	Motor output (W)	Feed screw	Lead (mm)	Max. Load Capacity		Rated thrust (N)	Positioning Repeatability (mm)	Stroke (mm)
				Horizontal (kg)	Vertical (kg)			
RCS2-GS5N-I-60-10-①-T2-②-③	60	Ball screw	10	5	1.5	89	±0.02	50 75
RCS2-GS5N-I-60-5-①-T2-②-③			5	10	3	178		
RCS2-GS5N-I-60-2.5-①-T2-②-③			2.5	20	6	356		

Code explanation ① Stroke ② Cable length ③ Options \*See page A-71 for details on push motion.

#### Stroke and Maximum Speed

Lead	Stroke	50 (mm)	75 (mm)
		10	280 <230>
5	250 <230>	250	
2.5	125		

\* The values enclosed in < > apply to vertical settings. (Unit: mm/s)

#### ① Stroke

Stroke (mm)	Standard price
50	—
75	—

#### ② Cable Length

Type	Cable symbol	Standard Price
Standard	P (1m)	—
	S (3m)	—
	M (5m)	—
Special length	X06 (6m) ~ X10 (10m)	—
	X11 (11m) ~ X15 (15m)	—
	X16 (16m) ~ X20 (20m)	—
Robot Cable	R01 (1m) ~ R03 (3m)	—
	R04 (4m) ~ R05 (5m)	—
	R06 (6m) ~ R10 (10m)	—
	R11 (11m) ~ R15 (15m)	—
	R16 (16m) ~ R20 (20m)	—

\* See page A-59 for cables for maintenance.

#### ③ Options

Name	Option code	See page	Standard price
Brake	B	→ A-42	—
CE compliance	CE	→ A-42	—
Connector cable exits (left)	K1	→ A-51	—
Connector cable exits (front)	K2	→ A-51	—
Connector cable exits (right)	K3	→ A-51	—

#### Actuator Specifications

Item	Description
Drive System	Ball screw, ø8mm, rolled C10
Lost Motion	0.1mm or less
Frame	Material: Aluminum, white alumite treated
Ambient operating temperature, humidity	0 to 40°C, 85% RH or less (Non-condensing)
Service life	5,000km or 50 million cycles

Dimensional Drawings

CAD drawings can be downloaded from the website. [www.intelligentactuator.com](http://www.intelligentactuator.com)

For Special Orders Appendix P.15



(\*1) Connect the motor and encoder cables here. See page A-59 for details on cables.  
 (\*2) After homing, the slider moves to the ME, therefore, please watch for any interference with surrounding objects.  
 ME: Mechanical end SE: Stroke end

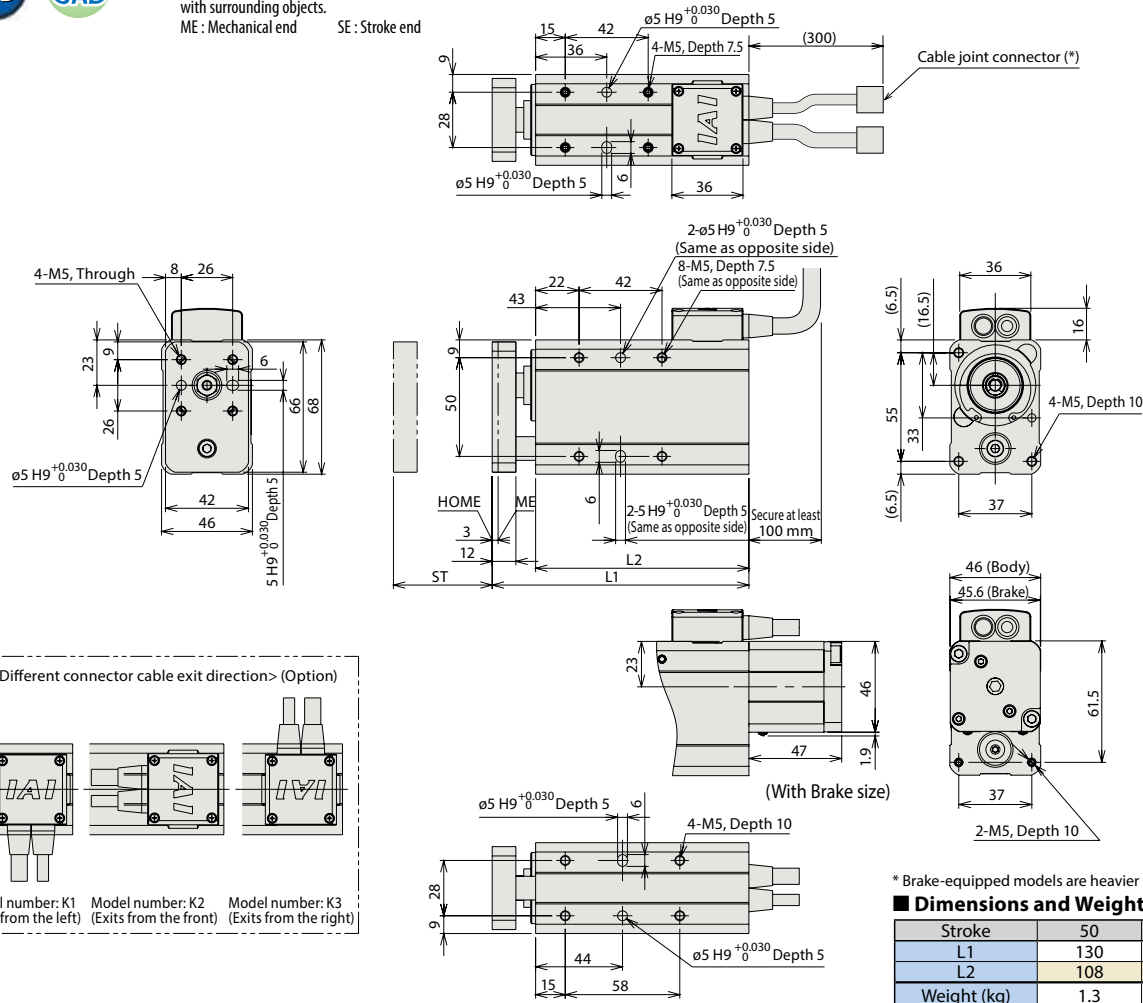

\* Brake-equipped models are heavier by 0.26kg.

■ Dimensions and Weight by Stroke			
Stroke	50	75	
L1	130	155	
L2	108	133	
Weight (kg)	1.3	1.4	

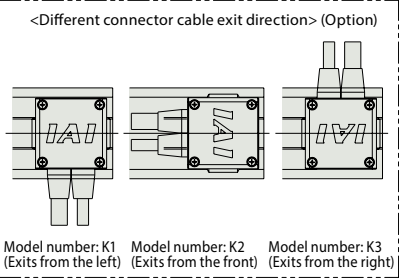

Applicable Controllers

RCS2 series actuators can be operated with the controllers indicated below. Select the type according to your intended application.

Name	External view	Model number	Features	Maximum number of positioning points	Input power	Power-supply capacity	Standard price	Reference page
Positioner Type		SCON-CA-60I-NP-2-①	Up to 512 positioning points are supported	512 points	Single-phase 100 VAC	218 VA max.  * Varies depending on the controller. Refer to the operation manual for details.	—	→ P643
Solenoid mode			Can be operated with the same controls used for solenoid valves	7 points				
Network mode			Can be moved by direct numerical specification	768 points				
Pulse-train input control mode			Can be controlled using pulse trains	(—)				
Program control type 1 or 2 axes		SSEL-CS-1-60I-NP-2-①	Program operation is supported Up to two axes can be operated	20,000 points	3-phase 200 VAC (XSEL-P/Q only)	—	→ P685	
Program control type 1 or 6 axes		XSEL-I-1-60I-N1-EEE-2-3	Program operation is supported Up to six axes can be operated	20,000 points				—

\* The values of SSEL and XSEL assume a 1-axis specification. \* ① indicates the type of power-supply voltage (1: 100 V/2: Single-phase 200 V). \* ② indicates the XSEL type (P/Q).

Please note that this model cannot be connected to the XSEL-P/Q type (5-axis/6-axis), XSEL-R/S type, or MSCON.



- Slider Type
- Mini
- Standard
- Controller Integrated
- Rod Type
- Mini
- Standard
- Controllers Integrated
- Table/Arm/Flat Type
- Mini
- Standard
- Gripper/Rotary Type
- Linear Servo Type
- Clean-room Type
- Splash-Proof Type
- Pulse Motor
- Servo Motor (24V)
- Servo Motor (200V)
- Linear Servo Motor



# RCS2-GD5N

Robo Cylinder, Mini Rod Type, Short-Length Double-Guide Type, Actuator Width 46mm, 200V Servo Motor, Ball Screw Specification

Model Specification Items	<b>RCS2</b>	<b>GD5N</b>	<b>I</b>	<b>60</b>	<input type="checkbox"/>	<input type="checkbox"/>	<b>T2</b>	<input type="checkbox"/>	<input type="checkbox"/>
	Series	Type	Encoder type	Motor type	Lead	Stroke	Applicable controller	Cable length	Options
			I: Incremental specification	60: 60W Servo motor	10: 10mm 5: 5mm 2.5: 2.5mm	50: 50mm 75: 75mm	T2: SCON-CA SSEL XSEL-P/Q	N: None P: 1m S: 3m M: 5m X <input type="checkbox"/> : Custom Length R <input type="checkbox"/> : Robot Cable	See options below.

\* See page Pre-47 for details on the model descriptions.



\*CE compliance is optional.



Technical References Appendix P.5

- POINT**  
Notes on selection
- (1) The horizontal payload is the value when used in combination with a guide so that a radial load and moment load are not applied to the rod. See page A-111 for correlation diagrams of the end load and service life when a guide is not installed.
  - (2) The payload is the value when the actuator is operated at an acceleration of 0.3 G (0.2G for 2.5mm-lead) horizontally and 0.2G vertically. The acceleration limit is the value indicated above.
  - (3) If the actuator is used vertically, pay attention to rod contact because the rod will come down when the power is turned off.
  - (4) See page A-71 for details on push motion.

### Actuator Specifications

#### Leads and Payloads

Model number	Motor output (W)	Feed screw	Lead (mm)	Max. Load Capacity		Rated thrust (N)	Positioning Repeatability (mm)	Stroke (mm)
				Horizontal (kg)	Vertical (kg)			
RCS2-GD5N-I-60-10-①-T2-②-③	60	Ball screw	10	5	1.5	89	±0.02	50 75
RCS2-GD5N-I-60-5-①-T2-②-③			5	10	3	178		
RCS2-GD5N-I-60-2.5-①-T2-②-③			2.5	20	6	356		

Code explanation ① Stroke ② Cable length ③ Options \*See page A-71 for details on push motion.

#### Stroke and Maximum Speed

Stroke / Lead	50 (mm)	75 (mm)
	10	280 <230>
5	250 <230>	250
2.5	125	

\* The values enclosed in < > apply to vertical settings. (Unit: mm/s)

#### ① Stroke

Stroke (mm)	Standard price
50	—
75	—

#### ② Cable Length

Type	Cable symbol	Standard Price
Standard	P (1m)	—
	S (3m)	—
	M (5m)	—
Special length	X06 (6m) ~ X10 (10m)	—
	X11 (11m) ~ X15 (15m)	—
	X16 (16m) ~ X20 (20m)	—
Robot Cable	R01 (1m) ~ R03 (3m)	—
	R04 (4m) ~ R05 (5m)	—
	R06 (6m) ~ R10 (10m)	—
	R11 (11m) ~ R15 (15m)	—
	R16 (16m) ~ R20 (20m)	—

\* See page A-59 for cables for maintenance.

#### ③ Options

Name	Option code	See page	Standard price
Brake	B	→ A-42	—
CE compliance	CE	→ A-42	—
Connector cable exits (left)	K1	→ A-51	—
Connector cable exits (front)	K2	→ A-51	—
Connector cable exits (right)	K3	→ A-51	—

#### Actuator Specifications

Item	Description
Drive System	Ball screw, ø8mm, rolled C10
Lost Motion	0.1mm or less
Frame	Material: Aluminum, white alumite treated
Ambient operating temperature, humidity	0 to 40°C, 85% RH or less (Non-condensing)
Service life	5,000km or 50 million cycles

**265** RCS2-GD5N

## Dimensional Drawings

CAD drawings can be downloaded from the website.

[www.intelligentactuator.com](http://www.intelligentactuator.com)

For Special Orders

Appendix P.15



- (\*1) Connect the motor and encoder cables here. See page A-59 for details on cables.
- (\*2) After homing, the slider moves to the ME, therefore, please watch for any interference with surrounding objects.

ME : Mechanical end SE : Stroke end

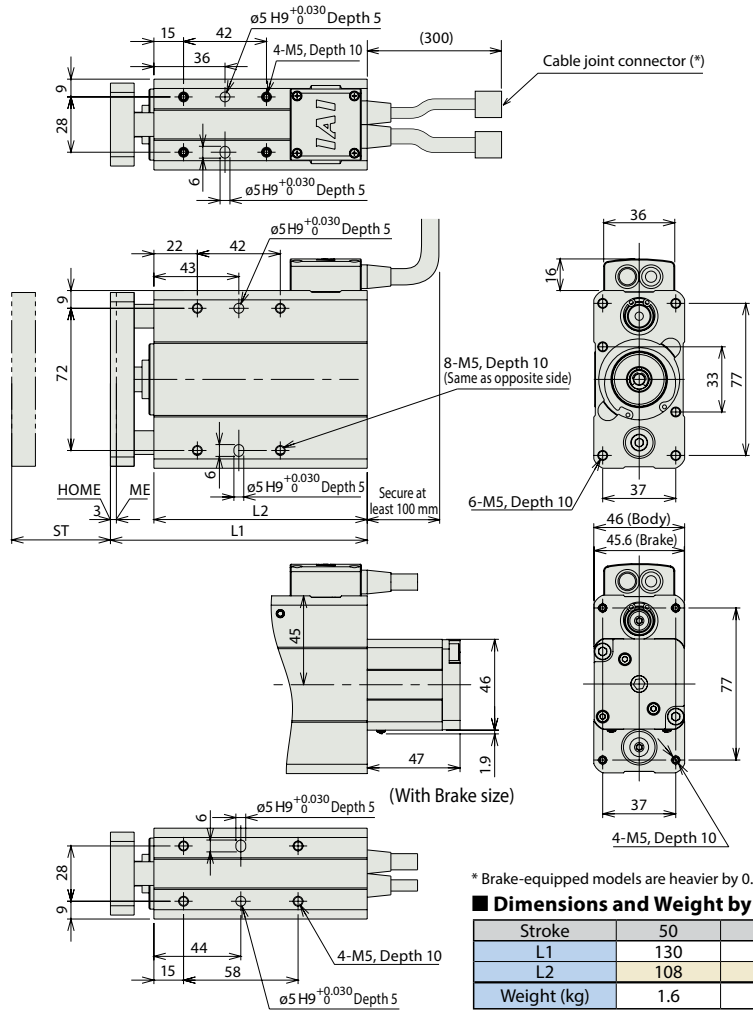
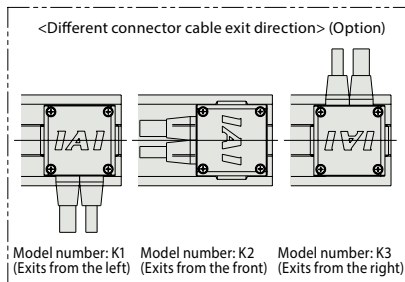
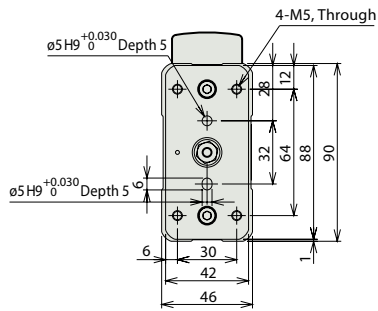

\* Brake-equipped models are heavier by 0.26kg.

### ■ Dimensions and Weight by Stroke

Stroke	50	75
L1	130	155
L2	108	133
Weight (kg)	1.6	1.9

### Applicable Controllers

RCS2 series actuators can be operated with the controllers indicated below. Select the type according to your intended application.

Name	External view	Model number	Features	Maximum number of positioning points	Input power	Power-supply capacity	Standard price	Reference page
Positioner Type		SCON-CA-60I-NP-2-①	Up to 512 positioning points are supported	512 points	Single-phase 100 VAC	218 VA max.	—	→ P643
Solenoid mode			Can be operated with the same controls used for solenoid valves	7 points				
Network mode			Can be moved by direct numerical specification	768 points				
Pulse-train input control mode			Can be controlled using pulse trains	(—)	Single-phase 200 VAC	—		
Program control type 1 or 2 axes		SSEL-CS-1-60I-NP-2-①	Program operation is supported Up to two axes can be operated	20,000 points	3-phase 200 VAC (XSEL-P/Q only)	* Varies depending on the controller. Refer to the operation manual for details.	—	→ P685
Program control type 1 or 6 axes		XSEL-①-1-60I-N1-EEE-2-3	Program operation is supported Up to six axes can be operated	20,000 points			—	→ P695

\* The values of SSEL and XSEL assume a 1-axis specification. \* ① indicates the type of power-supply voltage (1: 100 V/2: Single-phase 200 V). \* ①① indicates the XSEL type (P/Q).

Please note that this model cannot be connected to the XSEL-P/Q type (5-axis/6-axis), XSEL-R/S type, or MSCON.

# RCS2-SD5N

Robo Cylinder, Mini Rod Type, Short-Length Double-Guide Slide Unit Type, Actuator Width 94mm, 200V Servo Motor, Ball Screw Specification

Model Specification Items	<b>RCS2</b>	<b>SD5N</b>	<b>I</b>	<b>60</b>	<input type="checkbox"/>	<input type="checkbox"/>	<b>T2</b>	<input type="checkbox"/>	<input type="checkbox"/>
	Series	Type	Encoder type	Motor type	Lead	Stroke	Applicable controller	Cable length	Options
			I: Incremental specification	60: 60W Servo motor	10: 10mm 5: 5mm 2.5: 2.5mm	50: 50mm 75: 75mm	T2: SCON-CA SSEL XSEL-P/Q	N: None P: 1m S: 3m M: 5m X <input type="checkbox"/> : Custom Length R <input type="checkbox"/> : Robot Cable	See options below.

\* See page Pre-47 for details on the model descriptions.



\*CE compliance is optional.

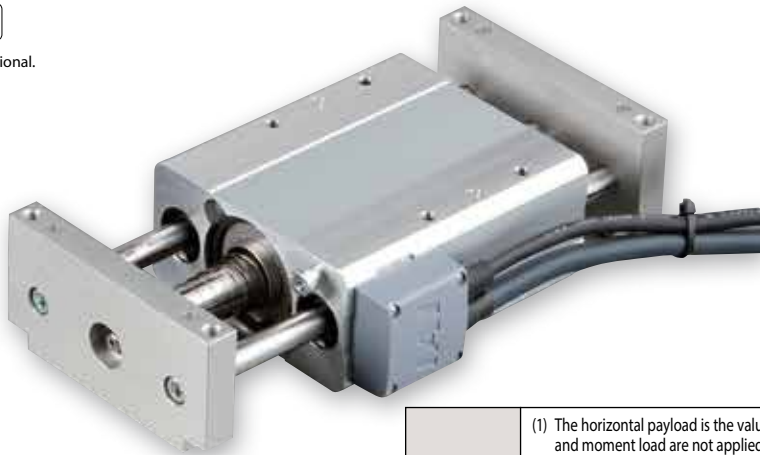

Technical References Appendix P.5

**POINT**  
Notes on selection

- (1) The horizontal payload is the value when used in combination with a guide so that a radial load and moment load are not applied to the rod. See page A-111 for correlation diagrams of the end load and service life when a guide is not installed.
- (2) The payload is the value when the actuator is operated at an acceleration of 0.3 G (0.2G for 2.5mm-lead) horizontally and 0.2G vertically. The acceleration limit is the value indicated above.
- (3) The vertical payload is the value when the actuator is mounted and side bracket is operated. Take note that in vertical operation, the side bracket cannot be mounted to operate the actuator.
- (4) If the actuator is used vertically, pay attention to rod contact because the rod will come down when the power is turned off.
- (5) See page A-71 for details on push motion.

### Actuator Specifications

#### Leads and Payloads

Model number	Motor output (W)	Feed screw	Lead (mm)	Max. Load Capacity		Rated thrust (N)	Positioning Repeatability (mm)	Stroke (mm)
				Horizontal (kg)	Vertical (kg)			
RCS2-SD5N-I-60-10-①-T2-②-③	60	Ball screw	10	5	1.5	89	±0.02	50 75
RCS2-SD5N-I-60-5-①-T2-②-③			5	10	3	178		
RCS2-SD5N-I-60-2.5-①-T2-②-③			2.5	20	6	356		

#### Stroke and Maximum Speed

Stroke Lead	50 (mm)	75 (mm)
	10	280 <230>
5	250 <230>	250
2.5	125	

Code explanation ① Stroke ② Cable length ③ Options \*See page A-71 for details on push motion.

\* The values enclosed in < > apply to vertical settings. (Unit: mm/s)

#### ① Stroke

Stroke (mm)	Standard price
50	—
75	—

#### ② Cable Length

Type	Cable symbol	Standard Price
Standard	P (1m)	—
	S (3m)	—
	M (5m)	—
Special length	X06 (6m) ~ X10 (10m)	—
	X11 (11m) ~ X15 (15m)	—
	X16 (16m) ~ X20 (20m)	—
Robot Cable	R01 (1m) ~ R03 (3m)	—
	R04 (4m) ~ R05 (5m)	—
	R06 (6m) ~ R10 (10m)	—
	R11 (11m) ~ R15 (15m)	—
	R16 (16m) ~ R20 (20m)	—

\* See page A-59 for cables for maintenance.

#### ③ Options

Name	Option code	See page	Standard price
CE compliance	CE	→ A-42	—
Connector cable exits (left)	K1	→ A-51	—
Connector cable exits (right)	K3	→ A-51	—

#### Actuator Specifications

Item	Description
Drive System	Ball screw, Ø8mm, rolled C10
Lost Motion	0.1mm or less
Frame	Material: Aluminum, white alumite treated
Ambient operating temperature, humidity	0 to 40°C, 85% RH or less (Non-condensing)
Service life	5,000km or 50 million cycles

Dimensional Drawings

CAD drawings can be downloaded from the website. [www.intelligentactuator.com](http://www.intelligentactuator.com)

For Special Orders Appendix P.15



(\*1) Connect the motor-encoder integrated cable here. See page A-59 for details on cables.  
 (\*2) After homing, the slider moves to the ME, therefore, please watch for any interference with surrounding objects.  
 ME: Mechanical end SE: Stroke end

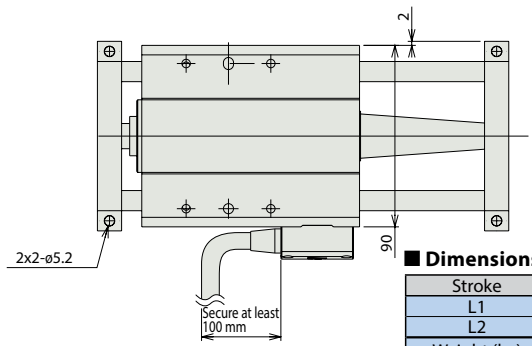
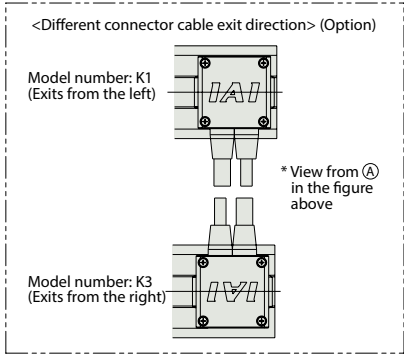
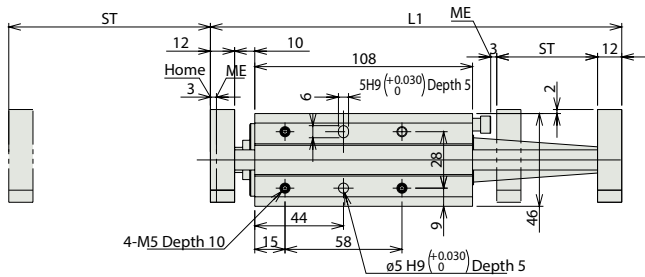
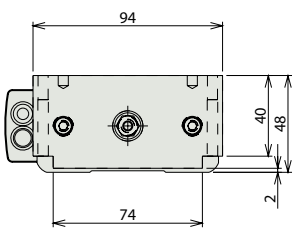
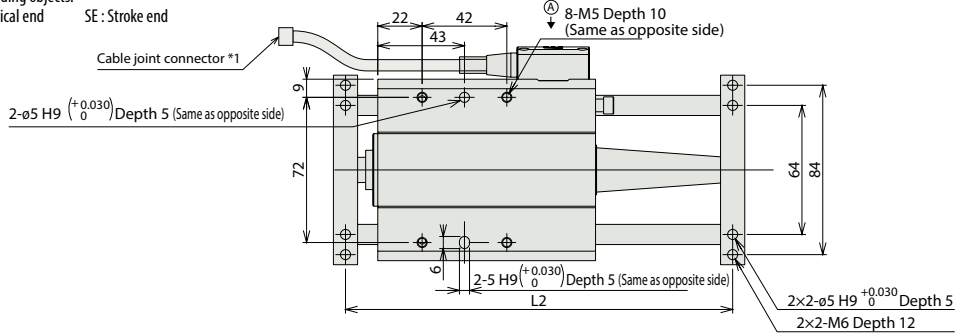

**Dimensions and Weight by Stroke**

Stroke	50	75
L1	204	229
L2	192	217
Weight (kg)	1.9	1.94

Applicable Controllers

RCS2 series actuators can be operated with the controllers indicated below. Select the type according to your intended application.

Name	External view	Model number	Features	Maximum number of positioning points	Input power	Power-supply capacity	Standard price	Reference page
Positioner Type		SCON-CA-60I-NP-2-①	Up to 512 positioning points are supported	512 points	Single-phase 100 VAC	218 VA max. * Varies depending on the controller. Refer to the operation manual for details.	—	→ P643
Solenoid mode			Can be operated with the same controls used for solenoid valves	7 points				
Network mode			Can be moved by direct numerical specification	768 points				
Pulse-train input control mode			Can be controlled using pulse trains	(—)				
Program control type 1 or 2 axes		SSEL-CS-1-60I-NP-2-①	Program operation is supported Up to two axes can be operated	20,000 points	3-phase 200 VAC (XSEL-P/Q only)	—	→ P685	
Program control type 1 or 6 axes		XSEL-①-1-60I-N1-EEE-2-3	Program operation is supported Up to six axes can be operated	20,000 points				—

\* The values of SSEL and XSEL assume a 1-axis specification. \* ① indicates the type of power-supply voltage (1: 100 V/2: Single-phase 200 V). \* ①① indicates the XSEL type (P/Q).

Please note that this model cannot be connected to the XSEL-P/Q type (5-axis/6-axis), XSEL-R/S type, or MSCON.



# RCS2-RA4C

Robo Cylinder, Rod Type, ø37mm Diameter, 200V Servo Motor, Coupled

Model Specification Items	<b>RCS2</b> — <b>RA4C</b> —	Encoder type	Motor type	Lead	Stroke	Applicable controller	Cable length	Options
	Series — Type	1: Incremental A: Absolute	20:20W Servo motor 30:30W Servo motor	12: 12mm 6: 6mm 3: 3mm	50: 50mm 300: 300mm (50mm pitch increments)	T1: XSEL-J/K T2: SCON MSCON SSEL XSEL-P/Q XSEL-R/S	N: None P: 1m S: 3m M: 5m X□□: Custom Length R□□: Robot Cable	See options below.

\* See page Pre-47 for details on the model descriptions.



\*CE compliance is optional.

## For High Acceleration/Deceleration (\*1)

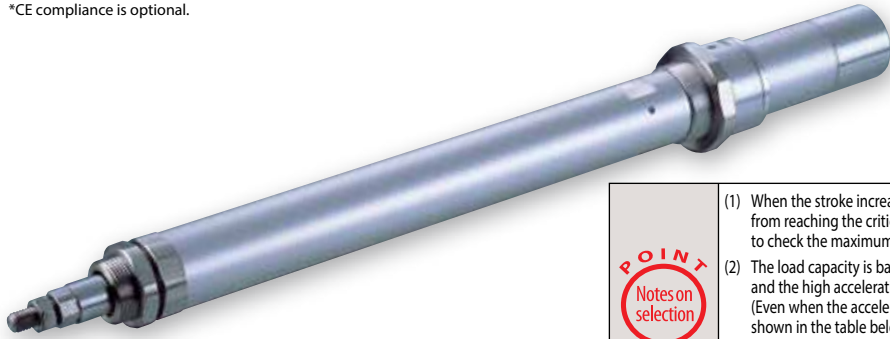

(\*1) Except all 20W models and 30W 3mm lead models

Technical References Appendix P.5

- POINT**  
Notes on selection
- (1) When the stroke increases, the maximum speed will drop to prevent the ball screw from reaching the critical rotational speed. Use the actuator specification table below to check the maximum speed at the stroke you desire.
  - (2) The load capacity is based on operation of the standard model at 0.3G (0.2G for 3mm-lead), and the high acceleration/deceleration model at 1G (excluding the 3mm-lead model). (Even when the acceleration/deceleration is dropped, the maximum load capacity values shown in the table below are the upper limits.)
  - (3) The values for the horizontal load capacity assume the use of an external guide, so that there is no external force from any direction other than the forward/backward direction of the rod.
  - (4) See page A-71 for details on push motion.

### Actuator Specifications

#### Leads and Payloads

Model number	Motor output (W)	Lead (mm)	Max. Load Capacity		Rated thrust (N)	Stroke (mm)
			Horizontal (kg)	Vertical (kg)		
RCS2-RA4C-①-20-12-②-③-④-⑤	20	12	3.0	1.0	18.9	50~300 (every 50mm)
RCS2-RA4C-①-20-6-②-③-④-⑤		6	6.0	2.0	37.7	
RCS2-RA4C-①-20-3-②-③-④-⑤		3	12.0	4.0	75.4	
RCS2-RA4C-①-30-12-②-③-④-⑤	30	12	4.0	1.5	28.3	
RCS2-RA4C-①-30-6-②-③-④-⑤		6	9.0	3.0	56.6	
RCS2-RA4C-①-30-3-②-③-④-⑤		3	18.0	6.5	113.1	

#### Stroke and Maximum Speed

Lead	Stroke	50~300 (every 50mm)
	12	600
6	300	
3	150	

(Unit: mm/s)

Code explanation ① Encoder ② Stroke ③ Applicable controller ④ Cable length ⑤ Options \*See page A-71 for details on push motion.

#### ① Encoder Type/② Stroke

② Stroke (mm)	Standard price			
	① Encoder Type			
	Incremental		Absolute	
	Motor Output (W)		Motor Output (W)	
	20W	30W	20W	30W
50	—	—	—	—
100	—	—	—	—
150	—	—	—	—
200	—	—	—	—
250	—	—	—	—
300	—	—	—	—

#### ⑤ Options

Name	Option code	See page	Standard price
Brake	B	→ A-42	—
CE compliance	CE	→ A-42	—
Foot bracket	FT	→ A-49	—
Flange bracket (front)	FL	→ A-45	—
Flange bracket (back)	FLR	→ A-47	—
High-acceleration/deceleration (*1)	HA	→ A-50	—
Home sensor (*2)	HS	→ A-50	—
Knuckle joint	NJ	→ A-53	—
Non-motor end specification	NM	→ A-52	—
Trunnion bracket (front)	TRF	→ A-57	—
Trunnion bracket (back)	TRR	→ A-58	—

(\*1) The high-acceleration/deceleration option is not available for all 20W models and 30W model with 3mm lead.  
(\*2) The home sensor (HS) cannot be used on the non-motor end models.

#### ④ Cable Length

Type	Cable symbol	Standard Price
Standard	P (1m)	—
	S (3m)	—
	M (5m)	—
Special length	X06 (6m) ~ X10 (10m)	—
	X11 (11m) ~ X15 (15m)	—
	X16 (16m) ~ X20 (20m)	—
Robot Cable	R01 (1m) ~ R03 (3m)	—
	R04 (4m) ~ R05 (5m)	—
	R06 (6m) ~ R10 (10m)	—
	R11 (11m) ~ R15 (15m)	—
	R16 (16m) ~ R20 (20m)	—

\* See page A-59 for cables for maintenance.

### Actuator Specifications

Item	Description
Drive System	Ball screw, ø10mm, rolled C10
Positioning Repeatability	±0.02mm
Lost Motion	0.1mm or less
Base	Material: Aluminum, white alumite treated
Rod diameter	ø20mm
Non-rotating accuracy of rod	±1.0 deg
Ambient operating temperature, humidity	0 to 40°C, 85% RH or less (Non-condensing)

- Slider Type
- Mini
- Standard
- Controller Integrated
- Rod Type
- Mini
- Standard
- Controllers Integrated
- Table/Arm/Flat Type
- Mini
- Standard
- Gripper/Rotary Type
- Linear Servo Type
- Clean-room Type
- Splash-Proof Type
- Pulse Motor
- Servo Motor (24V)
- Servo Motor (200V)
- Linear Servo Motor

Dimensional Drawings

CAD drawings can be downloaded from the website. [www.intelligentactuator.com](http://www.intelligentactuator.com)

For Special Orders Appendix P.15



- (\*1) Connect the motor and encoder cables here. See page A-59 for details on cables.
- (\*2) After homing, the slider moves to the ME, therefore, please watch for any interference with surrounding objects.  
ME: Mechanical end SE: Stroke end
- (\*3) The orientation of the bolt varies depending on the product.

[No Brake]

Note:  
Do not apply any external force on the rod from any direction other than the direction of the rod's motion. If a force is exerted on the rod in a perpendicular or rotational direction, the detent may become damaged.

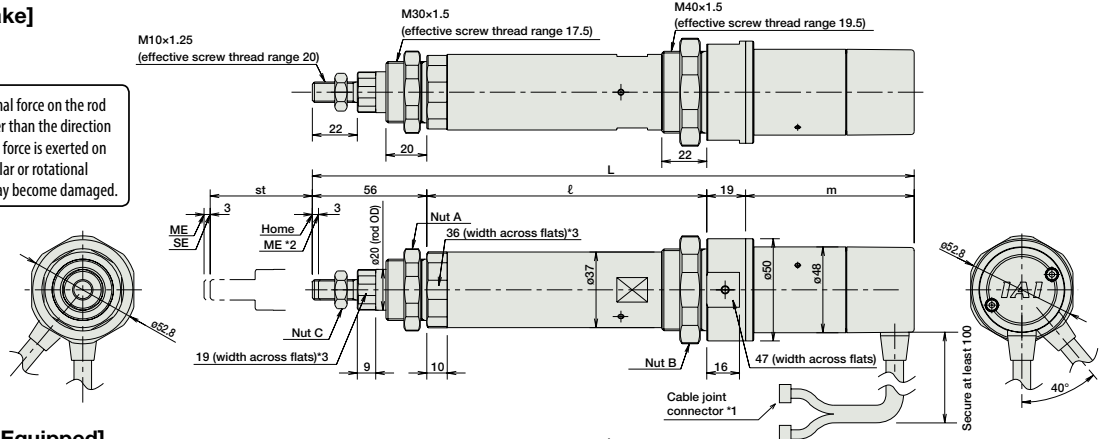

[Brake-Equipped]

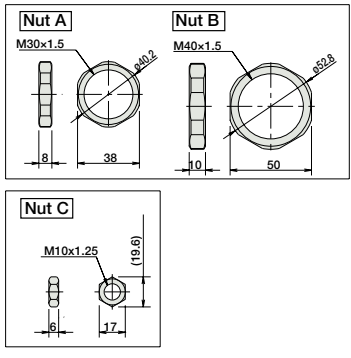
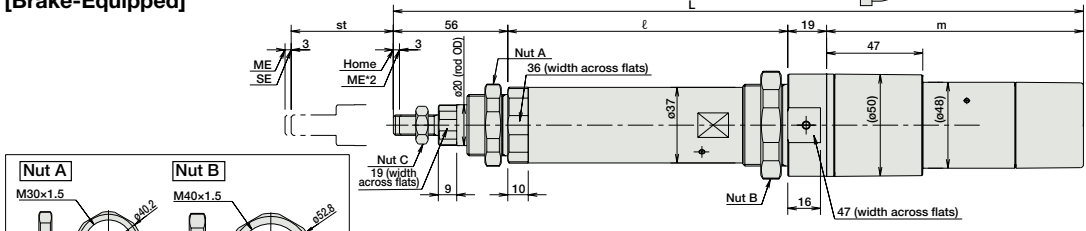

■ Dimensions and Weight by Stroke

RCS2-RA4C (without brake)							RCS2-RA4C (with brake)								
	Stroke	50	100	150	200	250	300		Stroke	50	100	150	200	250	300
L	20W	292.5	342.5	392.5	442.5	492.5	542.5	Single-phase 100VAC	20W	335.5	385.5	435.5	485.5	535.5	585.5
	30W	307.5	357.5	407.5	457.5	507.5	557.5		30W	350.5	400.5	450.5	500.5	550.5	600.5
	l	137	187	237	287	337	487		l	137	187	237	287	337	487
m	20W	80.5						Single-phase 200VAC	20W	123.5					
	30W	95.5							30W	138.5					
Weight (kg)		1.1	1.2	1.4	1.5	1.7	1.8	Weight (kg)		1.3	1.5	1.6	1.7	1.9	2.0

③ Applicable Controllers

RCS2-series actuators can be operated with the following controllers. Select an appropriate controller type according to your application.

Name	External view	Model number	Features	Maximum number of positioning points	Input power	Power supply capacity	Standard price	Reference page	
Positioner mode		SCON-CA-20①-NP-2-② SCON-CA-30D①-NP-2-②	Up to 512 positioning points are supported.	512 points	Single-phase 100VAC Single-phase 200VAC 3-phase 200VAC (XSEL-P/Q/R/S ONLY)	126 VA max. *Power supply capacity will vary depending on the controller, so please refer to the instruction manual for details.	—	→ P643	
Solenoid valve mode			Actuators can be operated through the same control used for solenoid valves.	7 points					
Field network type			Movement by numerical specification is supported.	768 points					
Pulse-train input control type			Dedicated pulse-train input type	(—)					
Positioner multi-axis, network type		MSCON-C-1-20①-④-0-② MSCON-C-1-30D①-④-0-②	Up to 6 axes can be operated. Movement by numerical specification is supported.	256 points	3-phase 200VAC (XSEL-P/Q/R/S ONLY)	126 VA max. *Power supply capacity will vary depending on the controller, so please refer to the instruction manual for details.	—	→ P655	
Program control type, 1 to 2 axes	SSEL-CS-1-20①-NP-2-② SSEL-CS-1-30D①-NP-2-②	Program operation is supported. Up to 2 axes can be operated.	20,000 points	—					→ P685
Program control type, 1 to 8 axes	XSEL-③-1-20①-N1-EEE-2-④ XSEL-③-1-30D①-N1-EEE-2-④	Program operation is supported. Up to 8 axes can be operated.	Varies depending on the number of axes connected	—					→ P695

\* This is for the single-axis MSCON, SSEL, and XSEL.  
 \* ① indicates the power-supply voltage type (1: 100V / 2: Single-phase 200V).  
 \* ② indicates the power-supply voltage type (1: 100V / 2: Single-phase 200V / 3: Three-phase 200V).  
 \* ③ indicates the encoder type (I: Incremental / A: Absolute).  
 \* ④ indicates the XSEL type (J / K / P / Q / R / S).  
 \* ⑤ indicates field network specification symbol.



RCS2-RA4C Sold & Serviced By

# 270

**ELECTROMATE**

Toll Free Phone (877) SERV098  
 Toll Free Fax (877) SERV099  
[www.electromate.com](http://www.electromate.com)  
[sales@electromate.com](mailto:sales@electromate.com)

# RCS2-RA5C

Robo Cylinder, Rod Type, Actuator Width 55mm, 200V Servo Motor, Coupled

Model Specification Items	<b>RCS2</b> — <b>RA5C</b> —	—	—	—	—	—	—	—	—	—
	Series	Type	Encoder type	Motor type	Lead	Stroke	Applicable controller	Cable length	Options	
			I: Incremental A: Absolute	60: 60W Servo motor 100: 100W Servo motor	16: 16mm 8: 8mm 4: 4mm	50: 50mm 300: 300mm (50mm pitch increments)	T1: XSEL-J/K T2: SCON MSCON SSEL XSEL-P/Q XSEL-R/S	N: None P: 1m S: 3m M: 5m X□□: Custom Length R□□: Robot Cable	See options below.	

\* See page Pre-47 for details on the model descriptions.



\*CE compliance is optional.



## For High Acceleration/Deceleration

(\*1)

(\*1) Except all 60W models and 100W 4mm lead models

Technical References Appendix P.5

- POINT**  
Notes on selection
- When the stroke increases, the maximum speed will drop to prevent the ball screw from reaching the critical rotational speed. Use the actuator specification table below to check the maximum speed at the stroke you desire.
  - The load capacity is based on operation of the standard model at 0.3G (0.2G for 4mm-lead), and the high acceleration/deceleration model at 1G (0.2G for 4mm-lead). (Even when the acceleration/deceleration is dropped, the maximum load capacity values shown in the table below are the upper limits.)
  - The values for the horizontal load capacity assume the use of an external guide, so that there is no external force from any direction other than the forward/backward direction of the rod.
  - See page A-71 for details on push motion.

### Actuator Specifications

#### Leads and Payloads

Model number	Motor output (W)	Lead (mm)	Max. Load Capacity		Rated thrust (N)	Stroke (mm)
			Horizontal (kg)	Vertical (kg)		
RCS2-RA5C-①-60-16-②-③-④-⑤	60	16	12.0	2.0	63.8	50~300 (every 50mm)
RCS2-RA5C-①-60-8-②-③-④-⑤		8	25.0	5.0	127.5	
RCS2-RA5C-①-60-4-②-③-④-⑤		4	50.0	11.5	255.1	
RCS2-RA5C-①-100-16-②-③-④-⑤	100	16	15.0	3.5	105.8	
RCS2-RA5C-①-100-8-②-③-④-⑤		8	30.0	9.0	212.7	
RCS2-RA5C-①-100-4-②-③-④-⑤		4	60.0	18.0	424.3	

#### Stroke and Maximum Speed

Lead	Stroke	50~250 (every 50mm)	300 (mm)
		16	800
8	400	377	
4	200	188	

(Unit: mm/s)

Code explanation ① Encoder ② Stroke ③ Applicable controller ④ Cable length ⑤ Options \*See page A-71 for details on push motion.

#### ① Encoder Type/② Stroke

② Stroke (mm)	Standard price			
	① Encoder Type			
	Incremental		Absolute	
	Motor Output (W)		Motor Output (W)	
	60W	100W	60W	100W
50	—	—	—	—
100	—	—	—	—
150	—	—	—	—
200	—	—	—	—
250	—	—	—	—
300	—	—	—	—

#### ④ Cable Length

Type	Cable symbol	Standard Price
Standard	P (1m)	—
	S (3m)	—
	M (5m)	—
Special length	X06 (6m) ~ X10 (10m)	—
	X11 (11m) ~ X15 (15m)	—
	X16 (16m) ~ X20 (20m)	—
	R01 (1m) ~ R03 (3m)	—
Robot Cable	R04 (4m) ~ R05 (5m)	—
	R06 (6m) ~ R10 (10m)	—
	R11 (11m) ~ R15 (15m)	—
	R16 (16m) ~ R20 (20m)	—

\* See page A-59 for cables for maintenance.

#### ⑤ Options

Name	Option code	See page	Standard price
Connector cable exit direction	A2	→ A-41	—
Brake	B	→ A-42	—
CE compliance	CE	→ A-42	—
Flange bracket	FL	→ A-45	—
Foot bracket	FT	→ A-49	—
High-acceleration/deceleration (*1)	HA	→ A-50	—

(\*1) The high-acceleration/deceleration option is not available for all 60W models and 100W model with 4mm lead.

#### Actuator Specifications

Item	Description
Drive System	Ball screw, ø12mm, rolled C10
Positioning Repeatability	±0.02mm
Lost Motion	0.1mm or less
Base	Material: Aluminum, white alumite treated
Rod diameter	ø30mm
Non-rotating accuracy of rod	±0.7 deg
Ambient operating temperature, humidity	0 to 40°C, 85% RH or less (Non-condensing)

Dimensional Drawings

CAD drawings can be downloaded from the website. [www.intelligentactuator.com](http://www.intelligentactuator.com)

For Special Orders Appendix P.15



\*The RA5C is not available in non-motor end configuration, due to its construction.

- (\*1) Connect the motor and encoder cables here. See page A-59 for details on cables.
- (\*2) After homing, the slider moves to the ME, therefore, please watch for any interference with surrounding objects.  
ME: Mechanical end SE: Stroke end
- (\*3) The orientation of the bolt varies depending on the product.

Note:  
Do not apply any external force on the rod from any direction other than the direction of the rod's motion. If a force is exerted on the rod in a perpendicular or rotational direction, the detent may become damaged.

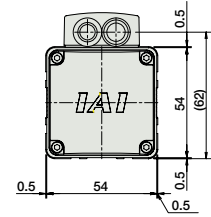
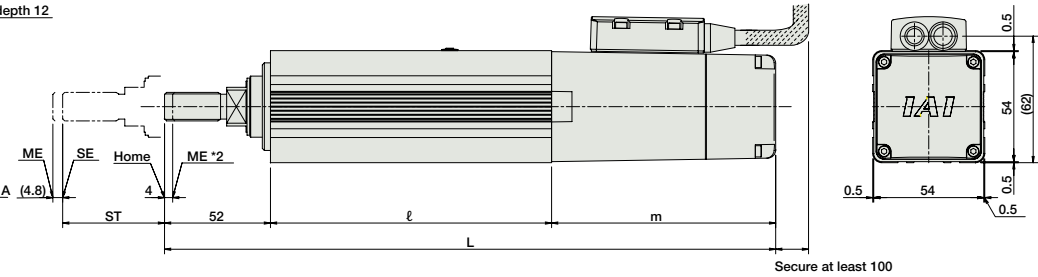
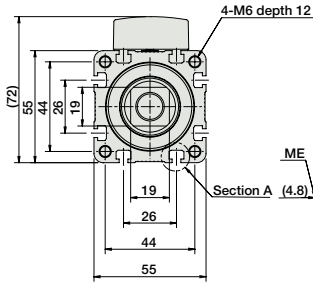
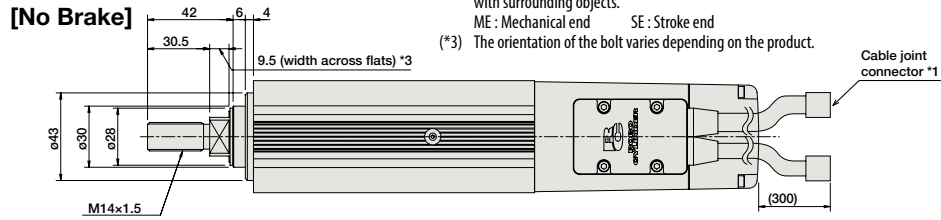

[Brake-Equipped]

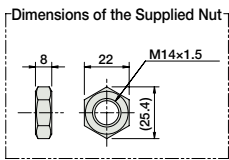
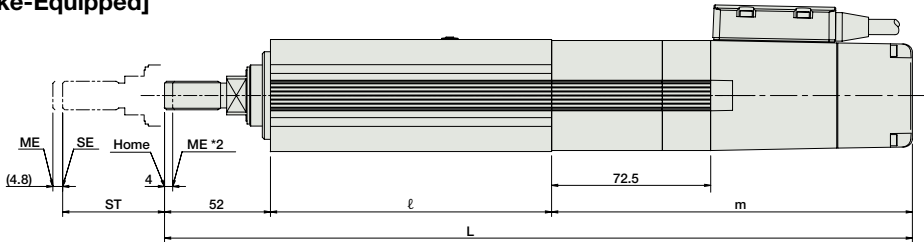
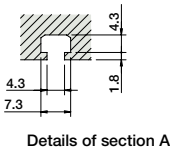

■ Dimensions and Weight by Stroke

RCS2-RA5C (without brake)		Stroke	50	100	150	200	250	300
L	60W	282	332	382	432	482	532	
	100W	300	350	400	450	500	550	
	l	138	188	238	288	338	388	
m	60W	92						
	100W	110						
Weight (kg)		1.9	2.2	2.5	2.8	3.1	3.4	

RCS2-RA5C (with brake)		Stroke	50	100	150	200	250	300
L	60W	354.5	404.5	454.5	504.5	554.5	604.5	
	100W	372.5	422.5	472.5	522.5	572.5	622.5	
	l	138	188	238	288	338	388	
m	60W	164.5						
	100W	182.5						
Weight (kg)		2.2	2.5	2.8	3.1	3.4	3.7	

③ Applicable Controllers

RCS2-series actuators can be operated with the following controllers. Select an appropriate controller type according to your application.

Name	External view	Model number	Features	Maximum number of positioning points	Input power	Power supply capacity	Standard price	Reference page
Positioner mode		SCON-CA-60①-NP-2-② SCON-CA-100①-NP-2-②	Up to 512 positioning points are supported.	512 points	Single-phase 100VAC Single-phase 200VAC 3-phase 200VAC (XSEL-P/Q/R/S ONLY)	314 VA max. *Power supply capacity will vary depending on the controller, so please refer to the instruction manual for details.	—	→ P643
Solenoid valve mode			Actuators can be operated through the same control used for solenoid valves.	7 points				
Field network type			Movement by numerical specification is supported.	768 points				
Pulse-train input control type			Dedicated pulse-train input type	(—)				
Positioner multi-axis, network type		MSCON-C-1-60①-④-0-② MSCON-C-1-100①-④-0-②	Up to 6 axes can be operated. Movement by numerical specification is supported.	256 points			—	→ P655
Program control type, 1 to 2 axes		SSEL-CS-1-60①-NP-2-② SSEL-CS-1-100①-NP-2-②	Program operation is supported. Up to 2 axes can be operated.	20,000 points			—	→ P685
Program control type, 1 to 8 axes		XSEL-③-1-60①-N1-EEE-2-④ XSEL-③-1-100①-N1-EEE-2-④	Program operation is supported. Up to 8 axes can be operated.	Varies depending on the number of axes connected			—	→ P695

\* This is for the single-axis MSCON, SSEL, and XSEL.  
 \* ① indicates the power-supply voltage type (1: 100V / 2: Single-phase 200V).  
 \* ② indicates the power-supply voltage type (1: 100V / 2: Single-phase 200V / 3: Three-phase 200V).  
 \* ③ indicates the encoder type (I: Incremental / A: Absolute).  
 \* ④ indicates the XSEL type (J / K / P / Q / R / S).  
 \* ⑤ indicates field network specification symbol.

- Slider Type
- Mini
- Standard
- Controller Integrated
- Rod Type
- Mini
- Standard
- Controllers Integrated
- Table/ Arm/ Flat Type
- Mini
- Standard
- Gripper/ Rotary Type
- Linear Servo Type
- Clean-room Type
- Splash-Proof Type
- Pulse Motor
- Servo Motor (24V)
- Servo Motor (200V)
- Linear Servo Motor



# RCS2-RA4D

Robo Cylinder, Rod Type, ø37mm Diameter, 200V Servo Motor, Built-in (Direct-Coupled) Motor

Model Specification Items	<b>RCS2</b> — <b>RA4D</b> —	Encoder type	Motor type	Lead	Stroke	Applicable controller	Cable length	Options
	Series — Type	I : Incremental A : Absolute	20 : 20W Servo motor 30 : 30W Servo motor	12 : 12mm 6 : 6mm 3 : 3mm	50: 50mm 300: 300mm (50mm pitch increments)	T1: XSEL-J/K T2: SCON MSCON SSEL XSEL-P/Q XSEL-R/S	N: None P: 1m S: 3m M: 5m X□□: Custom Length R□□: Robot Cable	See options below.

\* See page Pre-47 for details on the model descriptions.



\*CE compliance is optional.

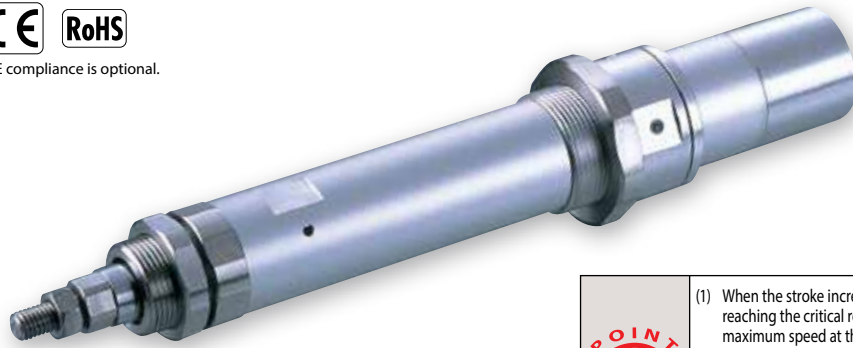

Technical References Appendix P.5

- POINT**  
Notes on selection
- (1) When the stroke increases, the maximum speed will drop to prevent the ball screw from reaching the critical rotational speed. Use the actuator specification table below to check the maximum speed at the stroke you desire.
  - (2) The load capacity is based on operation at an acceleration of 0.3G (0.2G for 3mm-lead model). This is the upper limit of the acceleration.
  - (3) The values for the horizontal load capacity assume the use of an external guide, so that there is no external force from any direction other than the forward/backward direction of the rod.
  - (4) See page A-71 for details on push motion.

### Actuator Specifications

#### Leads and Payloads

Model number	Motor output (W)	Lead (mm)	Max. Load Capacity		Rated thrust (N)	Stroke (mm)
			Horizontal (kg)	Vertical (kg)		
RCS2-RA4D-①-20-12-②-③-④-⑤	20	12	3.0	1.0	18.9	50~300 (every 50mm)
RCS2-RA4D-①-20-6-②-③-④-⑤		6	6.0	2.0	37.7	
RCS2-RA4D-①-20-3-②-③-④-⑤		3	12.0	4.0	75.4	
RCS2-RA4D-①-30-12-②-③-④-⑤	30	12	4.0	1.5	28.3	
RCS2-RA4D-①-30-6-②-③-④-⑤		6	9.0	3.0	56.6	
RCS2-RA4D-①-30-3-②-③-④-⑤		3	18.0	6.5	113.1	

#### Stroke and Maximum Speed

Lead	Stroke	50~300 (every 50mm)
	12	600
6	300	
3	150	

(Unit: mm/s)

Code explanation ① Encoder ② Stroke ③ Applicable controller ④ Cable length ⑤ Options \*See page A-71 for details on push motion.

#### ① Encoder Type/② Stroke

② Stroke (mm)	Standard price			
	① Encoder Type			
	Incremental		Absolute	
	Motor Output (W)		Motor Output (W)	
	20W	30W	20W	30W
50	—	—	—	—
100	—	—	—	—
150	—	—	—	—
200	—	—	—	—
250	—	—	—	—
300	—	—	—	—

#### ④ Cable Length

Type	Cable symbol	Standard Price
Standard	P (1m)	—
	S (3m)	—
	M (5m)	—
Special length	X06 (6m) ~ X10 (10m)	—
	X11 (11m) ~ X15 (15m)	—
	X16 (16m) ~ X20 (20m)	—
	R01 (1m) ~ R03 (3m)	—
Robot Cable	R04 (4m) ~ R05 (5m)	—
	R06 (6m) ~ R10 (10m)	—
	R11 (11m) ~ R15 (15m)	—
	R16 (16m) ~ R20 (20m)	—
	R16 (16m) ~ R20 (20m)	—

\* See page A-59 for cables for maintenance.

#### ⑤ Options

Name	Option code	See page	Standard price
CE compliance	CE	→ A-42	—
Foot bracket	FT	→ A-49	—
Flange bracket (front)	FL	→ A-45	—
Flange bracket (back)	FLR	→ A-46	—
Home sensor	HS	→ A-50	—
Knuckle joint	NJ	→ A-53	—
Non-motor end specification	NM	→ A-52	—
Trunnion bracket (front)	TRF	→ A-57	—
Trunnion bracket (back)	TRR	→ A-58	—

\*The home sensor (HS) cannot be used on the non-motor end models.

#### Actuator Specifications

Item	Description
Drive System	Ball screw, ø10mm, rolled C10
Positioning Repeatability	±0.02mm
Lost Motion	0.1mm or less
Base	Material: Aluminum, white alumite treated
Rod diameter	ø20mm
Non-rotating accuracy of rod	±1.0 deg
Ambient operating temperature, humidity	0 to 40°C, 85% RH or less (Non-condensing)

Dimensional Drawings

CAD drawings can be downloaded from the website. [www.intelligentactuator.com](http://www.intelligentactuator.com)

For Special Orders Appendix P.15



- (\*1) Connect the motor and encoder cables here. See page A-59 for details on cables.
- (\*2) After homing, the slider moves to the ME, therefore, please watch for any interference with surrounding objects.  
ME : Mechanical end SE : Stroke end
- (\*3) The orientation of the bolt varies depending on the product.

[No Brake]

Note:  
Do not apply any external force on the rod from any direction other than the direction of the rod's motion. If a force is exerted on the rod in a perpendicular or rotational direction, the detent may become damaged.

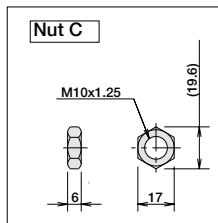
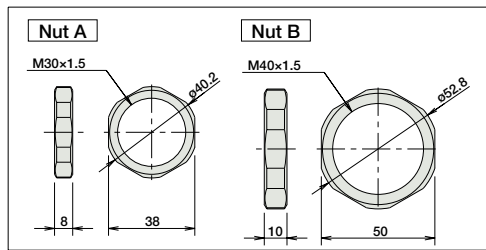
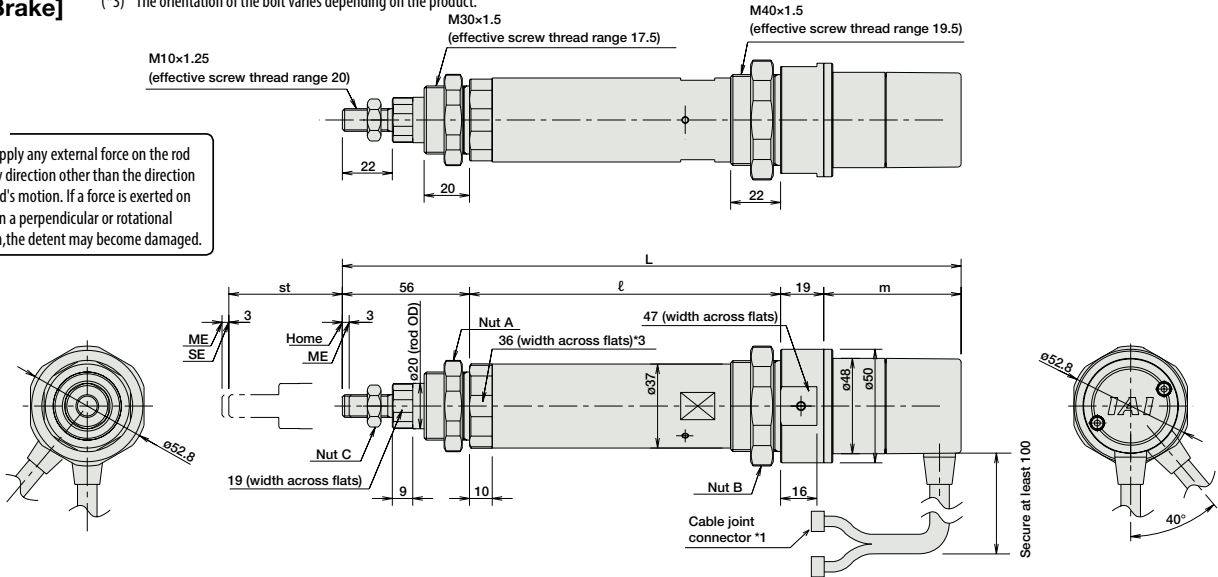

Dimensions and Weight by Stroke

RCS2-RA4D (without brake)								
Stroke	50	100	150	200	250	300		
L	20W	270.5	320.5	370.5	420.5	470.5	520.5	
	30W	285.5	335.5	385.5	435.5	485.5	535.5	
ℓ	137	187	237	287	337	487		
	20W	58.5						
m	30W	73.5						
	Weight (kg)	1.0	1.2	1.3	1.5	1.6	1.8	

RCS2-RA4D models are not equipped with a brake.

Applicable Controllers

RCS2-series actuators can be operated with the following controllers. Select an appropriate controller type according to your application.

Name	External view	Model number	Features	Maximum number of positioning points	Input power	Power supply capacity	Standard price	Reference page
Positioner mode		SCON-CA-20①-NP-2-② SCON-CA-30D①-NP-2-②	Up to 512 positioning points are supported.	512 points	Single-phase 100VAC Single-phase 200VAC 3-phase 200VAC (XSEL-P/Q/R/S ONLY)	126 VA max. *Power supply capacity will vary depending on the controller, so please refer to the instruction manual for details.	—	→ P643
Solenoid valve mode			Actuators can be operated through the same control used for solenoid valves.	7 points				
Field network type			Movement by numerical specification is supported.	768 points				
Pulse-train input control type			Dedicated pulse-train input type	(—)				
Positioner multi-axis, network type		MSCON-C-1-20①-④-0-② MSCON-C-1-30D①-④-0-②	Up to 6 axes can be operated. Movement by numerical specification is supported.	256 points			—	→ P655
Program control type, 1 to 2 axes		SSEL-CS-1-20①-NP-2-② SSEL-CS-1-30D①-NP-2-②	Program operation is supported. Up to 2 axes can be operated.	20,000 points			—	→ P685
Program control type, 1 to 8 axes		XSEL-③-1-20①-N1-EEE-2-④ XSEL-③-1-30D①-N1-EEE-2-④	Program operation is supported. Up to 8 axes can be operated.	Varies depending on the number of axes connected			—	→ P695

\* This is for the single-axis MSCON, SSEL, and XSEL.  
 \* ① indicates the power-supply voltage type (1: 100V / 2: Single-phase 200V).  
 \* ② indicates the power-supply voltage type (1: 100V / 2: Single-phase 200V / 3: Three-phase 200V).  
 \* ③ indicates the encoder type (I: Incremental / A: Absolute).  
 \* ④ indicates the XSEL type (J / K / P / Q / R / S).  
 \* ⑤ indicates field network specification symbol.

# RCS2-SRA7BD

Robo Cylinder, Rod Type, Actuator Width 75mm, 200V Servo Motor, Short-Length Type

Model Specification Items	<b>RCS2</b>	<b>SRA7BD</b>	<b>I</b>						
	Series	Type	Encoder type	Motor type	Lead	Stroke	Applicable controller	Cable length	Options
	I: Incremental	60: 60W Servo motor 100: 100W Servo motor 150: 150W Servo Motor		16: 16mm 8: 8mm 4: 4mm	50: 50mm 300: 300mm (50mm pitch increments)	T1: XSEL-J/K T2: SCON SSEL XSEL-P/Q	N: None P: 1m S: 3m M: 5m X□□: Custom Length R□□: Robot Cable	See options below.	

\* See page Pre-47 for details on the model descriptions.



Technical References Appendix P.5

- POINT**  
Notes on selection
- When operated at the rated acceleration, the maximum load capacity is the load capacity at the rated acceleration.
  - When operated at the maximum acceleration, the maximum load capacity is the load capacity at the maximum acceleration.
  - If positioning repeatability and/or lost motion is required, the rotation of the rod must be restricted. In this case, select a model with a guide, or add a separate guide.
  - The standard model may exhibit vibration of the rod at long strokes. If this is an issue, select a model with a guide, or add a separate guide.
  - The values for the horizontal load capacity reflect the use of an external guide.
  - See page A-71 for details on push motion.

### Actuator Specifications

#### Leads and Payloads

Model number	Motor output (W)	Lead (mm)	Rated Acceleration (G)	Load Capacity at Rated Acceleration		Max Acceleration (G)	Load Capacity at Max. Acceleration		Rated thrust (N)	Stroke (mm)
				Horizontal (kg)	Vertical (kg)		Horizontal (kg)	Vertical (kg)		
RCS2-SRA7BD-I-60-16-①-②-③-④	60	16	0.25	5	2	0.35	2.5	1	63	50~300 (every 50mm)
RCS2-SRA7BD-I-60-8-①-②-③-④		8	0.15	10	5	0.25	5	2.5	127	
RCS2-SRA7BD-I-60-4-①-②-③-④		4	0.05	20	10	0.15	10	5	254	
RCS2-SRA7BD-I-100-16-①-②-③-④	100	16	0.3	10	3.5	0.4	5	1.5	103	
RCS2-SRA7BD-I-100-8-①-②-③-④		8	0.2	22	9	0.3	10	4.5	207	
RCS2-SRA7BD-I-100-4-①-②-③-④		4	0.1	40	19.5	0.2	20	9	414	
RCS2-SRA7BD-I-150-16-①-②-③-④	150	16	0.3	15	6.5	0.4	7.5	3	157	
RCS2-SRA7BD-I-150-8-①-②-③-④		8	0.2	35	14.5	0.3	17.5	7	314	
RCS2-SRA7BD-I-150-4-①-②-③-④		4	0.1	55	22.5	0.2	27.5	11	628	

#### Stroke and Maximum Speed

Stroke Lead	Stroke (mm)	
	Stroke	50~300 (every 50mm)
16	800	
8	400	
4	200	

(Unit: mm/s)

Code explanation ① Stroke ② Applicable controller ③ Cable length ④ Options \*The values for the horizontal load capacity reflect the use of an external guide. \*See page A-71 for details on push motion.

#### ① Stroke

① Stroke (mm)	Standard price		
	Motor Output (W)		
	60W	100W	150W
50	—	—	—
100	—	—	—
150	—	—	—
200	—	—	—
250	—	—	—
300	—	—	—

#### ③ Cable Length

Type	Cable symbol	Standard Price
Standard	P (1m)	—
	S (3m)	—
	M (5m)	—
Special length	X06 (6m) ~ X10 (10m)	—
	X11 (11m) ~ X15 (15m)	—
	X16 (16m) ~ X20 (20m)	—
Robot Cable	R01 (1m) ~ R03 (3m)	—
	R04 (4m) ~ R05 (5m)	—
	R06 (6m) ~ R10 (10m)	—
	R11 (11m) ~ R15 (15m)	—
	R16 (16m) ~ R20 (20m)	—

\* See page A-59 for cables for maintenance.

#### ④ Options

Name	Option code	See page	Standard price
Connector cable exit direction	A1~A3	→ A-41	—
Brake	B	→ A-42	—
Flange	FL	→ A-45	—
Foot bracket	FT	→ A-49	—
Extended rod tip	RE	→ A-54	—

#### Actuator Specifications

Item	Description
Drive System	Ball screw, ø12mm, rolled C10
Positioning Repeatability	±0.02mm
Lost Motion	0.1mm or less
Base	Material: Aluminum, white alumite treated
Rod diameter	ø35mm
Non-rotating accuracy of rod	—
Ambient operating temperature, humidity	0 to 40°C, 85% RH or less (Non-condensing)

Dimensional Drawings

CAD drawings can be downloaded from the website. [www.intelligentactuator.com](http://www.intelligentactuator.com)

For Special Orders Appendix P.15



\*The SRA7BD is not available in non-motor end configuration, due to its construction.

- (\*1) Connect the motor and encoder cables here. See page A-59 for details on cables.
- (\*2) After homing, the slider moves to the ME, therefore, please watch for any interference with surrounding objects.  
ST: Stroke  
SE: Stroke end  
ME: Mechanical end
- (\*3) The orientation of the bolt varies depending on the product.

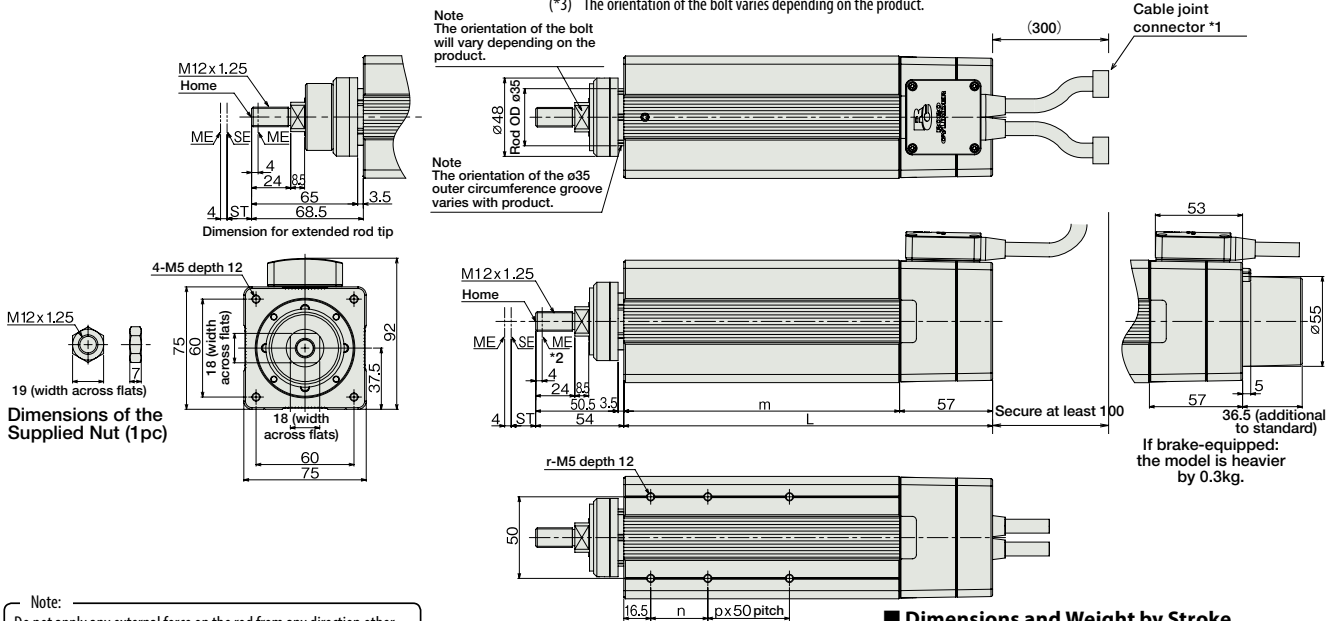

Note:  
Do not apply any external force on the rod from any direction other than the direction of the rod's motion. If a force is exerted on the rod in a perpendicular or rotational direction, the detent may become damaged.

Note:  
A slit is provided in the side of the actuator body to prevent pauses due to forward/backward operation. Please be careful when operating in the dusty environment. The dust may enter inside from the slit.

If brake-equipped: the model is heavier by 0.3kg.

Dimensions and Weight by Stroke

		Stroke	50	100	150	200	250	300
L	60W	126	176	226	276	326	376	
	100W	133	176	226	276	326	376	
	150W	145	176	226	276	326	376	
m	60W	69	119	169	219	269	319	
	100W	76	119	169	219	269	319	
	150W	88	119	169	219	269	319	
	n	25	35	35	35	35	35	
	p	0	0	1	2	3	4	
	r	4	4	6	8	10	12	
Weight (kg)	60W	2.4	2.9	3.5	4.1	4.6	5.2	
	100W	2.6	3.1	3.7	4.2	4.8	5.4	
	150W	2.9	3.3	3.9	4.4	5	5.6	

Applicable Controllers

RCS2 series actuators can be operated with the controllers indicated below. Select the type according to your intended application.

Name	External view	Model number	Features	Maximum number of positioning points	Input power	Power-supply capacity	Standard price	Reference page
Positioner mode		SCON-CA-①-I-NP-2-②	Up to 512 positioning points are supported.	512 points	Single-phase 100VAC	408 VA max.	—	→ P643
Solenoid valve mode			Actuators can be operated through the same control used for solenoid valves.	7 points				
Field network type			Movement by numerical specification is supported.	768 points				
Pulse-train input control type			Dedicated pulse-train input type	(—)				
Program control type 1 or 2 axes		SSEL-CS-1-①-I-NP-2-②	Program operation is supported Up to two axes can be operated	20,000 points	3-phase 200VAC (XSEL-P/Q only)	—	→ P685	
Program control type 1 or 6 axes		XSEL-③-1-①-I-N1-EEE-2-④	Program operation is supported Up to six axes can be operated	20,000 points				—

\* This is for the single-axis SSEL, and XSEL.  
 \* ① Indicates the power-supply voltage type (1: 100 V / 2: Single-phase 200 V).  
 \* ② Indicates the power-supply voltage type (1: 100 V / 2: Single-phase 200 V / 3: Three-phase 200 V).  
 \* ③ Indicates the wattage (60/100/150).  
 \* ④ Indicates the XSEL type (J / K / P / Q).

Please note that this model cannot be connected to the XSEL-P/Q type (5-axis/6-axis), XSEL-R/S type, or MSCON.

# RCS2-RA4R

Robo Cylinder, Rod Type, ø37mm Diameter, 200V Servo Motor, Side-mounted Motor

Model Specification Items	<b>RCS2</b> — <b>RA4R</b> —	Encoder type	Motor type	Lead	Stroke	Applicable controller	Cable length	Options
	Series — Type	I: Incremental A: Absolute	20: 20W Servo motor 30: 30W Servo motor	12: 12mm 6: 6mm 3: 3mm	50: 50mm 300: 300mm (50mm pitch increments)	T1: XSEL-J/K T2: SCON MSCON SSEL XSEL-P/Q XSEL-R/S	N: None P: 1m S: 3m M: 5m X□□: Custom Length R□□: Robot Cable	See options below.

\* See page Pre-47 for details on the model descriptions.



\*CE compliance is optional.

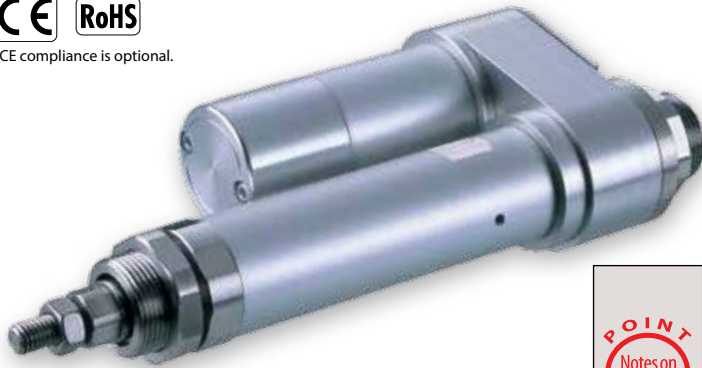

Technical References Appendix P.5

- POINT**  
Notes on selection
- (1) When the stroke increases, the maximum speed will drop to prevent the ball screw from reaching the critical rotational speed. Use the actuator specification table below to check the maximum speed at the stroke you desire.
  - (2) The load capacity is based on operation at an acceleration of 0.3G (0.2G for 3mm-lead model). This is the upper limit of the acceleration.
  - (3) The values for the horizontal load capacity assume the use of an external guide, so that there is no external force from any direction other than the forward/backward direction of the rod.
  - (4) See page A-71 for details on push motion.

### Actuator Specifications

#### Leads and Payloads

Model number	Motor output (W)	Lead (mm)	Max. Load Capacity		Rated thrust (N)	Stroke (mm)
			Horizontal (kg)	Vertical (kg)		
RCS2-RA4R-①-20-12-②-③-④-⑤	20	12	3.0	1.0	18.9	50~300 (every 50mm)
RCS2-RA4R-①-20-6-②-③-④-⑤		6	6.0	2.0	37.7	
RCS2-RA4R-①-20-3-②-③-④-⑤		3	12.0	4.0	75.4	
RCS2-RA4R-①-30-12-②-③-④-⑤	30	12	4.0	1.5	28.3	
RCS2-RA4R-①-30-6-②-③-④-⑤		6	9.0	3.0	56.6	
RCS2-RA4R-①-30-3-②-③-④-⑤		3	18.0	6.5	113.1	

#### Stroke and Maximum Speed

Lead	Stroke	50~300 (every 50mm)
	12	600
6	300	300
3	150	150

(Unit: mm/s)

Code explanation ① Encoder ② Stroke ③ Applicable controller ④ Cable length ⑤ Options \*See page A-71 for details on push motion.

#### ① Encoder Type/② Stroke

② Stroke (mm)	Standard price			
	① Encoder Type			
	Incremental		Absolute	
	Motor Output (W)		Motor Output (W)	
	20W	30W	20W	30W
50	—	—	—	—
100	—	—	—	—
150	—	—	—	—
200	—	—	—	—
250	—	—	—	—
300	—	—	—	—

#### ⑤ Options

Name	Option code	See page	Standard price
Brake	B	→ A-42	—
CE compliance	CE	→ A-42	—
Foot bracket	FT	→ A-49	—
Flange bracket (front)	FL	→ A-45	—
Flange bracket (back)	FLR	→ A-46	—
Home sensor	HS	→ A-50	—
Knuckle joint	NJ	→ A-53	—
Non-motor end specification	NM	→ A-52	—
Clevis bracket	QR	→ A-53	—
Back-mounting plate	RP	→ A-54	—
Trunnion bracket (front)	TRF	→ A-57	—

\*The home sensor (HS) cannot be used on the non-motor end models.

#### ④ Cable Length

Type	Cable symbol	Standard Price
Standard	P (1m)	—
	S (3m)	—
	M (5m)	—
Special length	X06 (6m) ~ X10 (10m)	—
	X11 (11m) ~ X15 (15m)	—
	X16 (16m) ~ X20 (20m)	—
	R01 (1m) ~ R03 (3m)	—
Robot Cable	R04 (4m) ~ R05 (5m)	—
	R06 (6m) ~ R10 (10m)	—
	R11 (11m) ~ R15 (15m)	—
	R16 (16m) ~ R20 (20m)	—
	R16 (16m) ~ R20 (20m)	—

\* See page A-59 for cables for maintenance.

### Actuator Specifications

Item	Description
Drive System	Ball screw, ø10mm, rolled C10
Positioning Repeatability	±0.02mm
Lost Motion	0.1mm or less
Base	Material: Aluminum, white alumite treated
Rod diameter	ø20mm
Non-rotating accuracy of rod	±1.0 deg
Ambient operating temperature, humidity	0 to 40°C, 85% RH or less (Non-condensing)

- Slider Type
- Mini
- Standard
- Controller Integrated
- Rod Type
- Mini
- Standard
- Controllers Integrated
- Table/Arm/Flat Type
- Mini
- Standard
- Gripper/Rotary Type
- Linear Servo Type
- Clean-room Type
- Splash-Proof Type
- Pulse Motor
- Servo Motor (24V)
- Servo Motor (200V)
- Linear Servo Motor

Dimensional Drawings

CAD drawings can be downloaded from the website. [www.intelligentactuator.com](http://www.intelligentactuator.com)

For Special Orders Appendix P.15



[No Brake]

Note:  
Do not apply any external force on the rod from any direction other than the direction of the rod's motion. If a force is exerted on the rod in a perpendicular or rotational direction, the detent may become damaged.

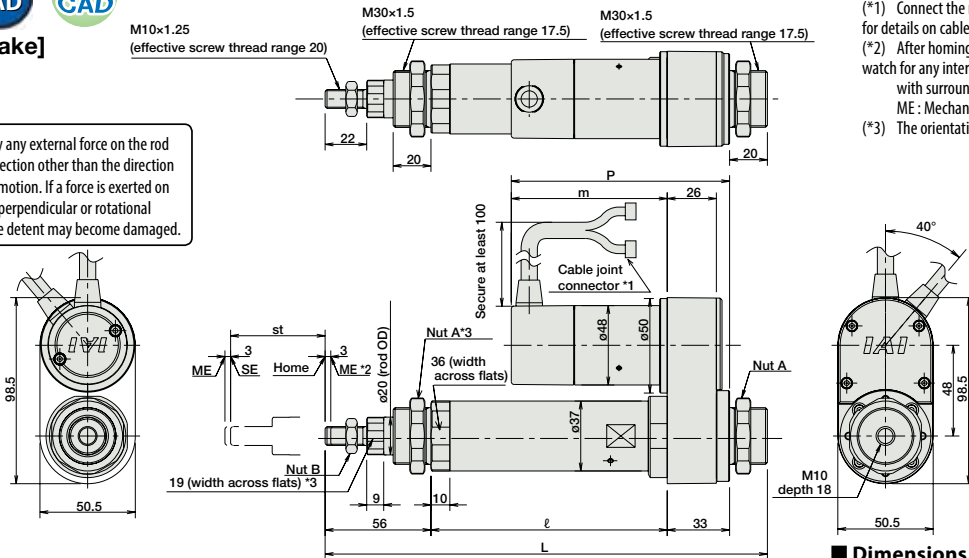

- (\*1) Connect the motor and encoder cables here. See page A-59 for details on cables.
- (\*2) After homing, the slider moves to the ME, therefore, please watch for any interference with surrounding objects.  
ME: Mechanical end SE: Stroke end
- (\*3) The orientation of the bolt varies depending on the product.

[Brake-Equipped]

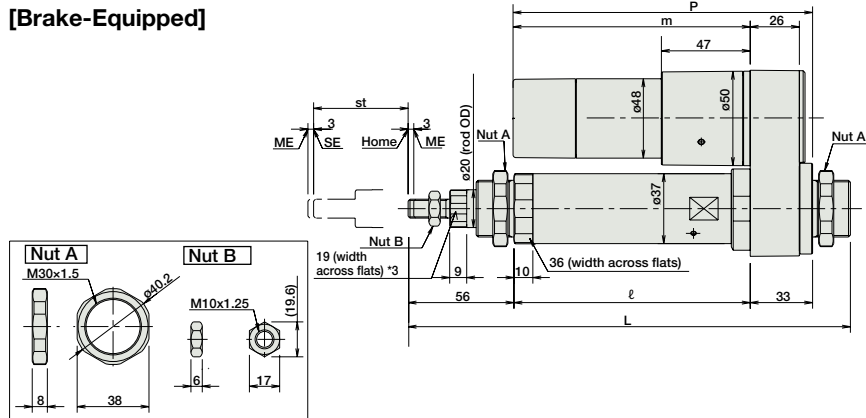

Dimensions and Weight by Stroke

**RCS2-RA4R (without brake)**

Stroke	50	100	150	200	250	300
L	20W	234	284	334	384	434
	30W	234	284	334	384	434
	ℓ	125	175	225	275	325
m	20W	80.5				
	30W	95.5				
p	20W	113.5				
	30W	128.5				
Weight (kg)	1.2	1.4	1.5	1.7	1.8	2.0

**RCS2-RA4R (with brake)**

Stroke	50	100	150	200	250	300
L	20W	234	284	334	384	434
	30W	234	284	334	384	434
	ℓ	125	175	225	275	325
m	20W	123.5				
	30W	138.5				
p	20W	156.5				
	30W	171.5				
Weight (kg)	1.4	1.6	1.7	1.9	2.0	2.2

Applicable Controllers

RCS2-series actuators can be operated with the following controllers. Select an appropriate controller type according to your application.

Name	External view	Model number	Features	Maximum number of positioning points	Input power	Power supply capacity	Standard price	Reference page	
Positioner mode		SCON-CA-20①-NP-2-② SCON-CA-30D①-NP-2-②	Up to 512 positioning points are supported.	512 points	Single-phase 100VAC Single-phase 200VAC 3-phase 200VAC (XSEL-P/Q/R/S ONLY)	126 VA max. *Power supply capacity will vary depending on the controller, so please refer to the instruction manual for details.	—	→ P643	
Solenoid valve mode			Actuators can be operated through the same control used for solenoid valves.	7 points					
Field network type			Movement by numerical specification is supported.	768 points					
Pulse-train input control type			Dedicated pulse-train input type	(—)					
Positioner multi-axis, network type		MSCON-C-1-20①-V-0-② MSCON-C-1-30D①-V-0-②	Up to 6 axes can be operated. Movement by numerical specification is supported.	256 points	—	—	→ P655		
Program control type, 1 to 2 axes		SSEL-CS-1-20①-NP-2-② SSEL-CS-1-30D①-NP-2-②	Program operation is supported. Up to 2 axes can be operated.	20,000 points				—	→ P685
Program control type, 1 to 8 axes		XSEL-③-1-20①-N1-EEE-2-④ XSEL-③-1-30D①-N1-EEE-2-④	Program operation is supported. Up to 8 axes can be operated.	Varies depending on the number of axes connected					

\* This is for the single-axis MSCON, SSEL, and XSEL.  
 \* ① indicates the power-supply voltage type (1: 100V / 2: Single-phase 200V).  
 \* ② indicates the power-supply voltage type (1: 100V / 2: Single-phase 200V / 3: Three-phase 200V).  
 \* ③ indicates the encoder type (I: Incremental / A: Absolute).  
 \* ④ indicates the XSEL type (J / K / P / Q / R / S).  
 \* ⑤ indicates field network specification symbol.

# RCS2-RA5R

Robo Cylinder, Rod Type, Actuator Width 55mm, 200V Servo Motor, Side-mounted Motor

Model Specification Items	<b>RCS2</b> — <b>RA5R</b> — <input type="checkbox"/> — <b>60</b> — <input type="checkbox"/> — <input type="checkbox"/> — <input type="checkbox"/> — <input type="checkbox"/>
	Series — Type — Encoder type — Motor type — Lead — Stroke — Applicable controller — Cable length — Options
	I: Incremental A: Absolute
	60: 60W Servo motor
	16: 16mm 8: 8mm 4: 4mm
	50: 50mm ? 300: 300mm (50mm pitch increments)
	T1: XSEL-J/K T2: SCON MSCON SSEL XSEL-P/Q XSEL-R/S
	N: None P: 1m S: 3m M: 5m X <input type="checkbox"/> : Custom Length (ML/MR) R <input type="checkbox"/> : Robot Cable
	See options below. * Be sure to specify which side the motor is to be mounted (ML/MR).

\* See page Pre-47 for details on the model descriptions.



\*CE compliance is optional.

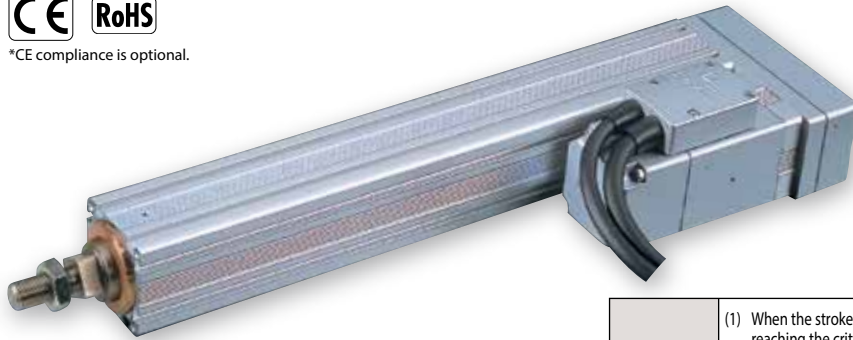

Technical References Appendix P.5

- POINT**  
Notes on selection
- (1) When the stroke increases, the maximum speed will drop to prevent the ball screw from reaching the critical rotational speed. Use the actuator specification table below to check the maximum speed at the stroke you desire.
  - (2) The load capacity is based on operation at an acceleration of 0.3G (0.2G for 4mm-lead model). This is the upper limit of the acceleration.
  - (3) The values for the horizontal load capacity assume the use of an external guide, so that there is no external force from any direction other than the forward/backward direction of the rod.
  - (4) See page A-71 for details on push motion.

### Actuator Specifications

#### Leads and Payloads

Model number	Motor output (W)	Lead (mm)	Max. Load Capacity		Rated thrust (N)	Stroke (mm)
			Horizontal (kg)	Vertical (kg)		
RCS2-RA5R-①-60-16-②-③-④-⑤	60	16	12.0	2.0	63.8	50~300 (every 50mm)
RCS2-RA5R-①-60-8-②-③-④-⑤		8	25.0	5.0	127.5	
RCS2-RA5R-①-60-4-②-③-④-⑤		4	50.0	11.5	255.1	

#### Stroke and Maximum Speed

Lead	Stroke	50~250 (every 50mm)	300 (mm)
		16	800
8	400	377	
4	200	188	

(Unit: mm/s)

Code explanation ① Encoder ② Stroke ③ Applicable controller ④ Cable length ⑤ Options \*See page A-71 for details on push motion.

#### ① Encoder Type/② Stroke

② Stroke (mm)	Standard price	
	① Encoder Type	
	Incremental	Absolute
50	I	A
100	—	—
150	—	—
200	—	—
250	—	—
300	—	—

#### ④ Cable Length

Type	Cable symbol	Standard Price
Standard	P (1m)	—
	S (3m)	—
	M (5m)	—
Special length	X06 (6m) ~ X10 (10m)	—
	X11 (11m) ~ X15 (15m)	—
	X16 (16m) ~ X20 (20m)	—
	R01 (1m) ~ R03 (3m)	—
Robot Cable	R04 (4m) ~ R05 (5m)	—
	R06 (6m) ~ R10 (10m)	—
	R11 (11m) ~ R15 (15m)	—
	R16 (16m) ~ R20 (20m)	—

\* See page A-59 for cables for maintenance.

#### ⑤ Options

Name	Option code	See page	Standard price
Connector cable exit direction	A2	→ A-41	—
Brake	B	→ A-42	—
CE compliance	CE	→ A-42	—
Flange	FL	→ A-45	—
Foot bracket	FT	→ A-49	—
Left-mounted motor (standard)	ML	→ A-52	—
Right-mounted motor	MR	→ A-52	—

#### Actuator Specifications

Item	Description
Drive System	Ball screw, ø12mm, rolled C10
Positioning Repeatability	±0.02mm
Lost Motion	0.1mm or less
Base	Material: Aluminum, white alumite treated
Rod diameter	ø30mm
Non-rotating accuracy of rod	±0.7 deg
Ambient operating temperature, humidity	0 to 40°C, 85% RH or less (Non-condensing)

Dimensional Drawings

CAD drawings can be downloaded from the website. [www.intelligentactuator.com](http://www.intelligentactuator.com)

For Special Orders Appendix P.15

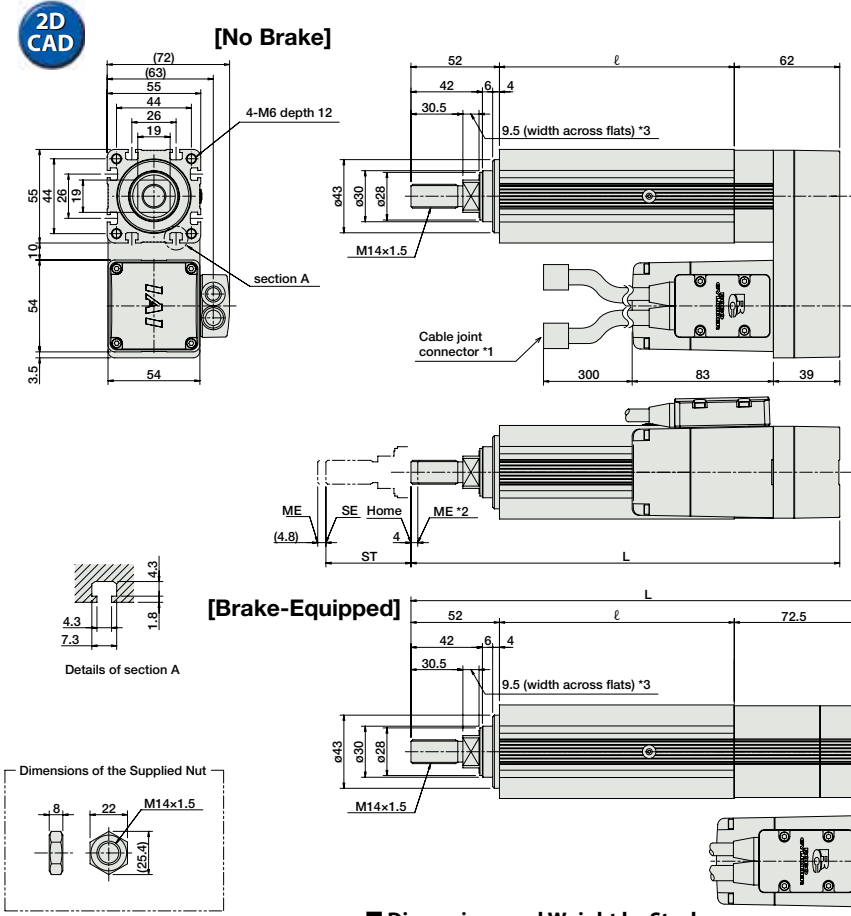

\*The RA5R is not available in non-motor end configuration, due to its construction.

- (\*1) Connect the motor and encoder cables here. See page A-59 for details on cables.
- (\*2) After homing, the slider moves to the ME, therefore, please watch for any interference with surrounding objects. ME: Mechanical end SE: Stroke end
- (\*3) The orientation of the bolt varies depending on the product.

Note:  
Do not apply any external force on the rod from any direction other than the direction of the rod's motion. If a force is exerted on the rod in a perpendicular or rotational direction, the detent may become damaged.

Dimensions and Weight by Stroke

RCS2-RA5R (without brake)						
Stroke	50	100	150	200	250	300
L	252	302	352	402	452	502
l	138	188	238	288	338	388
Weight (kg)	2.3	2.6	2.9	3.2	3.5	3.8

RCS2-RA5R (with brake)						
Stroke	50	100	150	200	250	300
L	301.5	351.5	401.5	451.5	501.5	551.5
l	138	188	238	288	338	388
Weight (kg)	2.6	2.9	3.2	3.5	3.8	4.1

Applicable Controllers

RCS2-series actuators can be operated with the following controllers. Select an appropriate controller type according to your application.

Name	External view	Model number	Features	Maximum number of positioning points	Input power	Power supply capacity	Standard price	Reference page			
Positioner mode		SCON-CA-60-①-NP-2-②③	Up to 512 positioning points are supported.	512 points	Single-phase 100VAC Single-phase 200VAC 3-phase 200VAC (XSEL-P/Q/R/S ONLY)	218 VA max. *Power supply capacity will vary depending on the controller, so please refer to the instruction manual for details.	—	→ P643			
Solenoid valve mode			Actuators can be operated through the same control used for solenoid valves.	7 points							
Field network type			Movement by numerical specification is supported.	768 points							
Pulse-train input control type			Dedicated pulse-train input type	(—)							
Positioner multi-axis, network type		MCON-C-1-60-①-④-0-③	Up to 6 axes can be operated. Movement by numerical specification is supported.	256 points			—	→ P655			
Program control type, 1 to 2 axes		SSEL-CS-1-60-①-NP-2-③	Program operation is supported. Up to 2 axes can be operated.	20,000 points						—	→ P685
Program control type, 1 to 8 axes		XSEL-V-1-60-①-N1-EEE-2-④	Program operation is supported. Up to 8 axes can be operated.	Varies depending on the number of axes connected							

\* This is for the single-axis MCON, SSEL, and XSEL.  
 \* ① indicates the power-supply voltage type (1: 100V / 2: Single-phase 200V).  
 \* ② indicates the power-supply voltage type (1: 100V / 2: Single-phase 200V / 3: Three-phase 200V).  
 \* ③ indicates the encoder type (I: Incremental / A: Absolute).  
 \* ④ indicates the XSEL type (J / K / P / Q / R / S).  
 \* ⑤ indicates field network specification symbol.





# RCS2-RA13R

Robo Cylinder, Ultra High Thrust Rod Type, Actuator Width 130mm, 200V Servo Motor, Side-mounted Motor

Model Specification Items	<b>RCS2</b>	<b>— RA13R</b>	<b>—</b>	<b>— 750</b>	<b>—</b>	<b>—</b>	<b>— T2</b>	<b>—</b>	<b>—</b>	<b>—</b>
	Series	Type	Encoder type	Motor type	Lead	Stroke	Applicable controller	Cable length	Options	
	I: Incremental A: Absolute	750: 750W Servo motor	2.5: 2.5mm 1.25: 1.25mm	50: 50mm 200: 200mm (50mm pitch increments)	T2: SCON SSEL XSEL-P/Q XSEL-R/S	N: None P: 1m S: 3m M: 5m X□□: Custom Length R□□: Robot Cable			See options below. * Please be sure to specify one of the codes for the motor mounting direction and the cable exit direction.	

\* See page Pre-47 for details on the model descriptions.



\*CE compliance is optional.



### Pushing Force vs. Current Limit

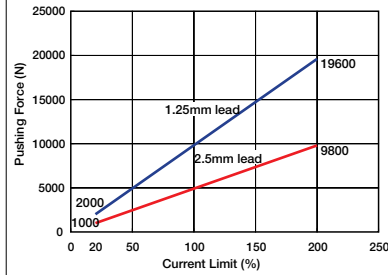

Note:

- The correlation between the pushing force and the current limit are only rough guide values, and may deviate from the actual numbers.
- The pushing force may be inconsistent if the current limit is low. Therefore, please set it at 20% or higher.
- The travel speed while the pushing force is acting is fixed at 10mm/s. The graph shows pushing action at 10mm/s. Please note that the pushing force will decrease if the speed changes.
- Depending on operational conditions, the pushing force may decrease due to the rise in the temperature of the motor.

\*Continuous pushing is allowed if the current limit value during push motion is equal to 70% or less, but there is a pushing time limit when 71% or more. See page A-83 for the details.

**POINT** Notes on selection

- (1) When performing pushing operation, duration of continuous use is preset for the set pushing force. In addition, the continuous thrust (with load and duty factored in) must be less than the rated thrust. For details, please see selection reference material (→page A-83).
- (2) The load capacity is based on operation at an acceleration of 0.02G for 2.5mm-lead, and 0.01G for 1.25mm-lead. This is the upper limit of the acceleration.
- (3) The values for the horizontal load capacity assume the use of an external guide, so that there is no external force from any direction other than the forward/backward direction of the rod.
- (4) The brake option requires, in addition to the actuator and the controller, a brake box (see accessories on page 282).

Technical References Appendix P.5

### Actuator Specifications

#### Leads and Payloads

Model number	Motor output (W)	Lead (mm)	Max Acceleration (G)	Max. Load Capacity		Rated thrust (N)	Continuous Pushing Force (N)	Maximum Push Force (N)	Stroke (mm)
				Horizontal (kg)	Vertical (kg)				
RCS2-RA13R-①-750-2.5-②-T2③-④	750	2.5	0.02	400	200	5106	3567	9800	50~200 (every 50mm)
RCS2-RA13R-①-750-1.25-②-T2③-④		1.25	0.01	500	300	10211	7141	19600	

Code explanation ① Encoder ② Stroke ③ Cable Length ④ Options

\* The values for the horizontal load capacity reflect the use of an external guide.

\* See page A-71 for details on push motion.

#### Stroke and Maximum Speed

Stroke Lead	Stroke			
	50	100	150	200
2.5	85	120	125	
1.25		62		

(Unit: mm/s)

#### ① Encoder Type/② Stroke

② Stroke (mm)	Standard price			
	① Encoder Type			
	Incremental		Absolute	
	1t type (2.5mm lead)	2t type (1.25mm lead)	1t type (2.5mm lead)	2t type (1.25mm lead)
50	—	—	—	—
100	—	—	—	—
150	—	—	—	—
200	—	—	—	—

#### ③ Cable Length

Type	Cable symbol	Standard Price
Standard	P (1m)	—
	S (3m)	—
	M (5m)	—
Special length	X06 (6m) ~ X10 (10m)	—
	X11 (11m) ~ X15 (15m)	—
	X16 (16m) ~ X20 (20m)	—
	R01 (1m) ~ R03 (3m)	—
Robot Cable	R04 (4m) ~ R05 (5m)	—
	R06 (6m) ~ R10 (10m)	—
	R11 (11m) ~ R15 (15m)	—
	R16 (16m) ~ R20 (20m)	—
	R16 (16m) ~ R20 (20m)	—

\* See page A-59 for cables for maintenance.

#### ④ Options

Name	Option code	See page	Standard price
Brake (with brake box)	B	→ A-42	—
Brake (without brake box)	BN	→ A-42	—
CE compliance	CE	→ A-42	—
Top-mounted motor	MT1/MT2/MT3	→ P282	—
Right-mounted motor	MR1/MR2	→ P282	—
Left-mounted motor	ML1/ML3	→ P282	—
Flange	FL	→ A-46	—
Foot bracket	FT	→ A-49	—
Load cell type (with cable track)	LCT	→ A-51	—
Load cell type (without cable track)	LCN	→ A-51	—

(Note:)  
The load cell type option can be operable only when the SCON-CA controller is used.  
The load cell type (with cable track) option and a flange option cannot be selected simultaneously.

#### Actuator Specifications

Item	Description
Drive System	Ball screw, ø32mm, rolled C10
Positioning Repeatability	±0.01mm
Backlash	0.2mm or less
Rod diameter	ø50mm (ball spline)
Allowable load moment of the rod	120 N·m
Ambient operating temperature, humidity	0 to 40°C, 85% RH or less (Non-condensing)
Push force service life	10 million pushes (*1)

(\*1) The number of pushes arwe based on the maximum pushing force and a distance of 1mm.

## Dimensional Drawings

CAD drawings can be downloaded from the website. [www.intelligentactuator.com](http://www.intelligentactuator.com)

For Special Orders Appendix P.15

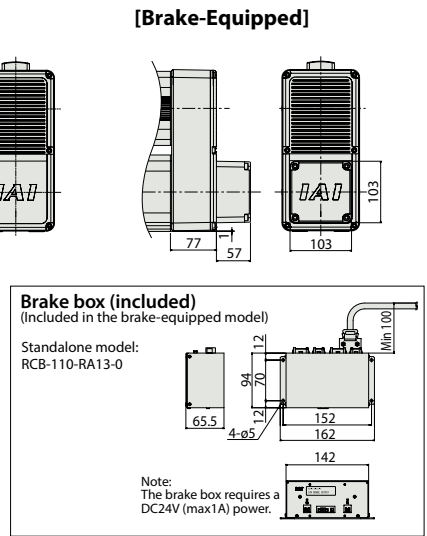
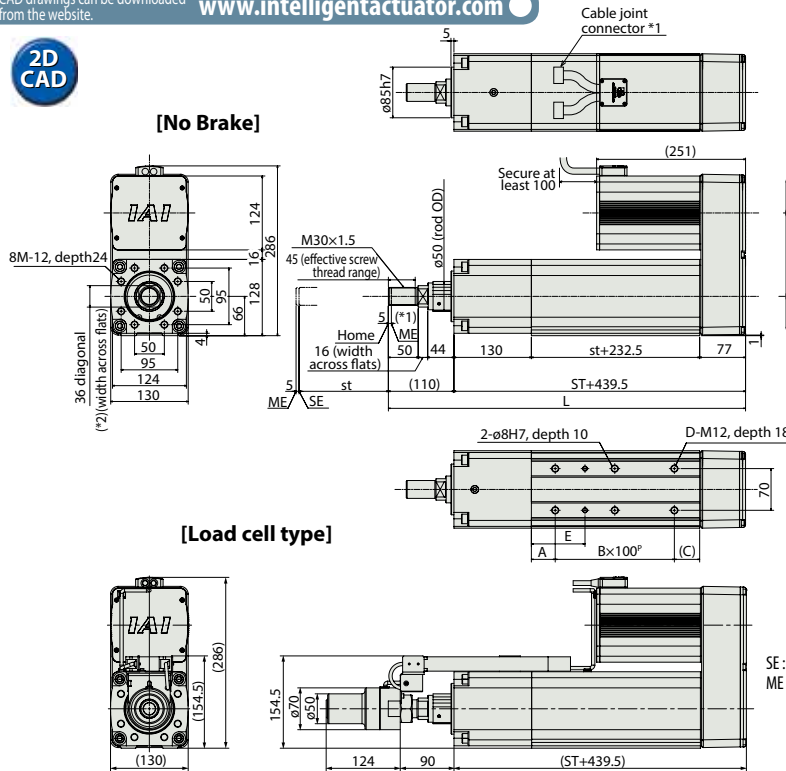

### Dimensions and Weight by Stroke RCS2-RA13R

\* Adding a brake will increase the actuator's overall length by 57mm, and its weight by 2.0kg.

Stroke	50	100	150	200
L	599.5	649.5	699.5	749.5
A	40	65	40	65
B	2	2	3	3
C	42.5	67.5	42.5	67.5
D	6	6	8	8
E	90	115	90	115
Weight (kg)	33	34	35	36

- (\*1) Connect the motor and encoder cables here. See page A-59 for details on cables.
- (\*2) During home return, be careful to avoid interference from peripheral objects because the slider travels until the mechanical end.
- (\*3) The orientation of the bolt varies depending on the product.

Note:  
The brake-equipped model (option code: "-B") always comes with a brake box. If you want to order just the brake-equipped actuator, specify the option code "-BN".

### Motor-mounting direction / Cable exit direction (options)

Note:  
Please be sure to specify one of the codes for the motor mounting direction and the cable exit direction.

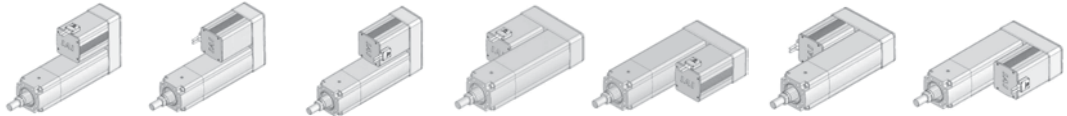

Option Code	MT1	MT2	MT3	MR1	ML1	MR2	ML3
Motor-mounting direction	Top (standard)	Top	Top	Right	Left	Right	Left
Cable exit direction	Top (standard)	Right	Left	Top	Top	Right	Left

### Applicable Controllers

RCS2 series actuators can be operated with the controllers indicated below. Select the type according to your intended application.

Name	External view	Model number	Features	Maximum number of positioning points	Input power	Power-supply capacity	Standard price	Reference page
Positioner mode		(Standard) SCON-CA-750①-NP-2-2	Up to 512 positioning points are supported.	512 points	Single-Phase 200VAC (SCON-CA/SSEL only)	1569VA max.	—	→ P643
Solenoid valve mode		(Load cell type) SCON-CA-750S①-NP-2-2	Actuators can be operated through the same control used for solenoid valves.	7 points				
Field network type			Movement by numerical specification is supported.	768 points				
Pulse-train input control type			Dedicated pulse-train input type	(—)	Three-phase 200VAC (XSEL-P/Q/R/S only)			
Program control type 1 or 2 axes		SSEL-CS-1-750①-NP-2	Program operation is supported Up to two axes can be operated	20,000 points			—	→ P685
Program control type 1 or 6 axes		XSEL-④-1-750①-N1-EEE-2-④	Program operation is supported Up to eight axes can be operated	Varies depending on the number of axes connected			—	→ P695

\* This is for the single-axis SSEL, and XSEL. \* ① Indicates the encoder type (I: Incremental / A: Absolute).  
\* ④ Indicates the XSEL type (P / Q / R / S). \* ④ Indicates the power-supply voltage type (1: 100 V / 2: Single-phase 200 V / 3: Three-phase 200 V).  
(Note) The load cell type option can be operable only when the SCON-CA controller is used.



RCS2-RA13R



Toll Free Phone (877) SERV098  
Toll Free Fax (877) SERV099  
[www.electromate.com](http://www.electromate.com)  
[sales@electromate.com](mailto:sales@electromate.com)

- Slider Type
- Mini
- Standard
- Controller Integrated
- Rod Type
- Mini
- Standard
- Controllers Integrated
- Table/Arm/Flat Type
- Mini
- Standard
- Gripper/Rotary Type
- Linear Servo Type
- Clean-room Type
- Splash-Proof Type
- Pulse Motor
- Servo Motor (24V)
- Servo Motor (200V)
- Linear Servo Motor

# RCS2-RGS4C

Robo Cylinder, Rod Type with Single Guide, ø37mm Diameter, 200V Servo Motor, Coupled

Model Specification Items	<b>RCS2</b>	<b>-RGS4C-</b>	<input type="checkbox"/>	<input type="checkbox"/>	<input type="checkbox"/>	<input type="checkbox"/>	<input type="checkbox"/>	<input type="checkbox"/>	<input type="checkbox"/>
	Series	Type	Encoder type	Motor type	Lead	Stroke	Applicable controller	Cable length	Options
	I: Incremental A: Absolute	20: 20W Servo motor 30: 30W Servo motor	12: 12mm 6: 6mm 3: 3mm	50: 50mm 300: 300mm (50mm pitch increments)	T1: XSEL-J/K T2: SCON MSCON SSEL XSEL-P/Q XSEL-R/S	N: None P: 1m S: 3m M: 5m X□□: Custom Length R□□: Robot Cable	See options below.		

\* See page Pre-47 for details on the model descriptions.



**For High Acceleration/Deceleration**

\*CE compliance is optional. (\*1)



(\*1) Except all 20W models and 30W 3mm lead models

**Technical References** Appendix P.5



- (1) When the stroke increases, the maximum speed will drop to prevent the ball screw from reaching the critical rotational speed. Use the actuator specification table below to check the maximum speed at the stroke you desire.
- (2) The load capacity is based on operating the standard and power-saving models at 0.3G (0.2G for 3mm-lead), and 1G acceleration for the high-acceleration models (3mm-lead model excluded). (The values in the table below are the upper limits, even if the acceleration/deceleration is decreased.)
- (3) The values for the horizontal load capacity assume the use of an external guide, so that there is no external force from any direction other than the forward/backward direction of the rod. See the technical resources (page A-111) for the allowable weight using the supplied guide alone.
- (4) See page A-71 for details on push motion.

### Actuator Specifications

#### Leads and Payloads

Model number	Motor output (W)	Lead (mm)	Max. Load Capacity		Rated thrust (N)	Stroke (mm)
			Horizontal (kg)	Vertical (kg)		
RCS2-RGS4C-①-20-12-②-③-④-⑤	20	12	3.0	0.5	18.9	50~300 (every 50mm)
RCS2-RGS4C-①-20-6-②-③-④-⑤		6	6.0	1.5	37.7	
RCS2-RGS4C-①-20-3-②-③-④-⑤		3	12.0	3.5	75.4	
RCS2-RGS4C-①-30-12-②-③-④-⑤	30	12	4.0	1.0	28.3	
RCS2-RGS4C-①-30-6-②-③-④-⑤		6	9.0	2.5	56.6	
RCS2-RGS4C-①-30-3-②-③-④-⑤		3	18.0	6.0	113.1	

#### Stroke and Maximum Speed

Lead	Stroke	50~300 (every 50mm)
	12	600
6	300	300
3	150	150

(Unit: mm/s)

Code explanation ① Encoder ② Stroke ③ Applicable controller ④ Cable length ⑤ Options \*See page A-71 for details on push motion.

#### ① Encoder Type/② Stroke

② Stroke (mm)	Standard price			
	① Encoder Type			
	Incremental		Absolute	
	Motor Output (W)		Motor Output (W)	
	20W	30W	20W	30W
50	—	—	—	—
100	—	—	—	—
150	—	—	—	—
200	—	—	—	—
250	—	—	—	—
300	—	—	—	—

#### ④ Cable Length

Type	Cable symbol	Standard Price
Standard	P (1m)	—
	S (3m)	—
	M (5m)	—
Special length	X06 (6m) ~ X10 (10m)	—
	X11 (11m) ~ X15 (15m)	—
	X16 (16m) ~ X20 (20m)	—
	R01 (1m) ~ R03 (3m)	—
Robot Cable	R04 (4m) ~ R05 (5m)	—
	R06 (6m) ~ R10 (10m)	—
	R11 (11m) ~ R15 (15m)	—
	R16 (16m) ~ R20 (20m)	—

\* See page A-59 for cables for maintenance.

#### ⑤ Options

Name	Option code	See page	Standard price
Brake	B	→ A-42	—
CE compliance	CE	→ A-42	—
Foot bracket	FT	→ A-49	—
High-acceleration/deceleration (*1)	HA	→ A-50	—
Home sensor (*2)	HS	→ A-50	—
Non-motor end specification	NM	→ A-52	—
Trunnion bracket (back)	TRR	→ A-58	—

(\*1) The high-acceleration/deceleration option is not available for all 20W models and 30W model with 3mm lead.  
(\*2) The home sensor (HS) cannot be used on the non-motor end models.

#### Actuator Specifications

Item	Description
Drive System	Ball screw, ø10mm, rolled C10
Positioning Repeatability	±0.02mm
Lost Motion	0.1mm or less
Guide	Single guide (guide rod diameter ø10mm, ball bush type)
Rod diameter	ø20mm
Non-rotating accuracy of rod	±0.05 deg
Ambient operating temperature, humidity	0 to 40°C, 85% RH or less (Non-condensing)

Slider Type

Mini

Standard

Controller Integrated

Rod Type

Mini

Standard

Controllers Integrated

Table/Arm/Flat Type

Mini

Standard

Gripper/Rotary Type

Linear Servo Type

Clean-room Type

Splash-Proof Type

Pulse Motor

Servo Motor (24V)

Servo Motor (200V)

Linear Servo Motor

Dimensional Drawings

CAD drawings can be downloaded from the website. [www.intelligentactuator.com](http://www.intelligentactuator.com)



[No Brake]

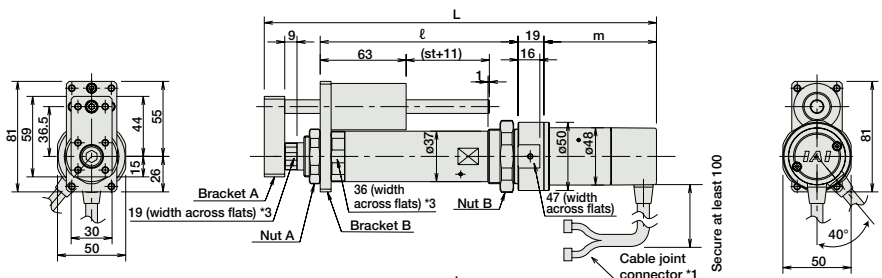
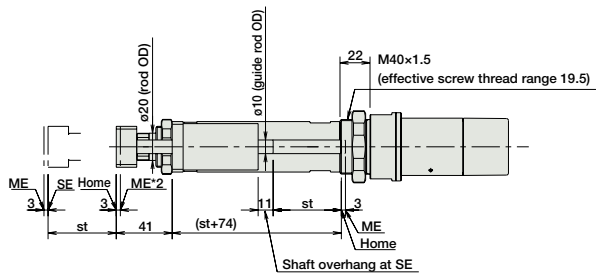

[Brake-Equipped]

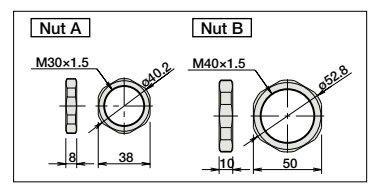
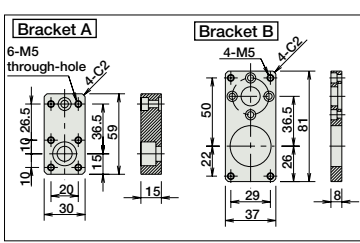
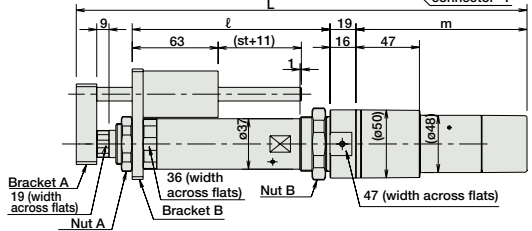

For Special Orders Appendix P.15

- (\*1) Connect the motor and encoder cables here. See page A-59 for details on cables.
- (\*2) After homing, the slider moves to the ME, therefore, please watch for any interference with surrounding objects.  
ME : Mechanical end SE : Stroke end
- (\*3) The orientation of the bolt varies depending on the product.

Dimensions and Weight by Stroke

RCS2-RGS4C (without brake)

Stroke	50	100	150	200	250	300	
L	20W	285.5	335.5	385.5	435.5	485.5	535.5
	30W	300.5	350.5	400.5	450.5	500.5	550.5
ℓ	20W	145	195	245	295	345	395
	30W	80.5					
m	20W	80.5					
	30W	95.5					
Weight (kg)	20W	1.5	1.6	1.8	2.0	2.2	2.4
	30W	95.5					

RCS2-RGS4C (with brake)

Stroke	50	100	150	200	250	300	
L	20W	328.5	387.5	428.5	478.5	528.5	578.5
	30W	343.5	393.5	443.5	493.5	543.5	593.5
ℓ	20W	145	195	245	295	345	395
	30W	123.5					
m	20W	123.5					
	30W	138.5					
Weight (kg)	20W	1.7	1.8	2.0	2.2	2.4	2.6
	30W	138.5					

Applicable Controllers

RCS2-series actuators can be operated with the following controllers. Select an appropriate controller type according to your application.

Name	External view	Model number	Features	Maximum number of positioning points	Input power	Power supply capacity	Standard price	Reference page	
Positioner mode		SCON-CA-20①-NP-2-② SCON-CA-30D①-NP-2-②	Up to 512 positioning points are supported.	512 points	Single-phase 100VAC Single-phase 200VAC 3-phase 200VAC (XSEL-P/Q/R/S ONLY)	126 VA max. *Power supply capacity will vary depending on the controller, so please refer to the instruction manual for details.	—	→ P643	
Solenoid valve mode			Actuators can be operated through the same control used for solenoid valves.	7 points					
Field network type			Movement by numerical specification is supported.	768 points					
Pulse-train input control type			Dedicated pulse-train input type	(—)					
Positioner multi-axis, network type		MSCON-C-1-20①-④-0-② MSCON-C-1-30D①-④-0-②	Up to 6 axes can be operated. Movement by numerical specification is supported.	256 points	—	—	→ P655		
Program control type, 1 to 2 axes		SSEL-CS-1-20①-NP-2-② SSEL-CS-1-30D①-NP-2-②	Program operation is supported. Up to 2 axes can be operated.	20,000 points				—	→ P685
Program control type, 1 to 8 axes		XSEL-③-1-20①-N1-EEE-2-④ XSEL-③-1-30D①-N1-EEE-2-④	Program operation is supported. Up to 8 axes can be operated.	Varies depending on the number of axes connected					

\* This is for the single-axis MSCON, SSEL, and XSEL.  
 ① indicates the power-supply voltage type (1: 100V / 2: Single-phase 200V).  
 ② indicates the encoder type (I: Incremental / A: Absolute).  
 ③ indicates the XSEL type (J / K / P / Q / R / S).  
 ④ indicates field network specification symbol.  
 \* indicates power-supply voltage type (1: 100V / 2: Single-phase 200V / 3: Three-phase 200V).  
 \* indicates field network specification symbol.



# RCS2-RGS5C

Robo Cylinder, Rod Type with Single Guide, Actuator Width 55mm, 200V Servo Motor, Coupled

Model Specification Items	<b>RCS2</b>	<b>— RGS5C</b>	<input type="checkbox"/>	<input type="checkbox"/>	<input type="checkbox"/>	<input type="checkbox"/>	<input type="checkbox"/>	<input type="checkbox"/>	<input type="checkbox"/>
	Series	Type	Encoder type	Motor type	Lead	Stroke	Applicable controller	Cable length	Options
	I: Incremental A: Absolute	60: 60W Servo motor 100: 100W Servo motor	16: 16mm 8: 8mm 4: 4mm	50: 50mm 300: 300mm (50mm pitch increments)	T1: XSEL-J/K T2: SCON MSCON SSEL XSEL-P/Q XSEL-R/S	N: None P: 1m S: 3m M: 5m X□□: Custom Length R□□: Robot Cable	See options below.		

\* See page Pre-47 for details on the model descriptions.



**For High Acceleration/Deceleration**

\*CE compliance is optional. (\*1)

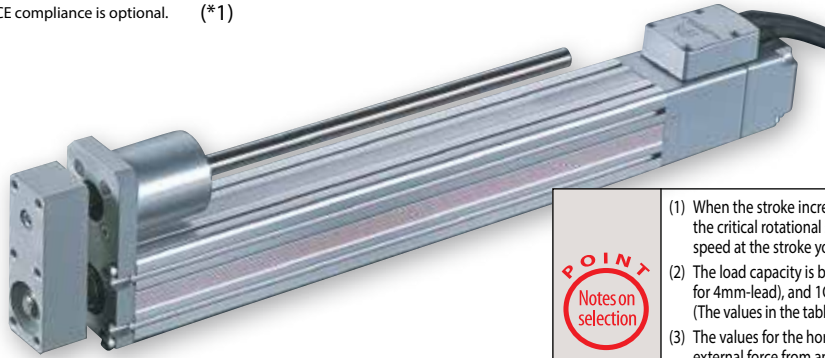

(\*1) Except all 60W models and 100W 4mm lead models

**Technical References** Appendix P.5



- (1) When the stroke increases, the maximum speed will drop to prevent the ball screw from reaching the critical rotational speed. Use the actuator specification table below to check the maximum speed at the stroke you desire.
- (2) The load capacity is based on operating the standard and power-saving models at 0.3G (0.2G for 4mm-lead), and 1G acceleration for the high-acceleration models (4mm-lead model excluded). (The values in the table below are the upper limits, even if the acceleration/deceleration is decreased.)
- (3) The values for the horizontal load capacity assume the use of an external guide, so that there is no external force from any direction other than the forward/backward direction of the rod. See the technical resources (page A-111) for the allowable weight using the supplied guide alone.
- (4) See page A-71 for details on push motion.

### Actuator Specifications

#### Leads and Payloads

Model number	Motor output (W)	Lead (mm)	Max. Load Capacity		Rated thrust (N)	Stroke (mm)
			Horizontal (kg)	Vertical (kg)		
RCS2-RGS5C-①-60-16-②-③-④-⑤	60	16	12.0	1.3	63.8	50~300 (every 50mm)
RCS2-RGS5C-①-60-8-②-③-④-⑤		8	25.0	4.3	127.5	
RCS2-RGS5C-①-60-4-②-③-④-⑤		4	50.0	10.8	255.1	
RCS2-RGS5C-①-100-16-②-③-④-⑤	100	16	15.0	2.8	105.8	
RCS2-RGS5C-①-100-8-②-③-④-⑤		8	30.0	8.3	212.7	
RCS2-RGS5C-①-100-4-②-③-④-⑤		4	60.0	17.3	424.3	

#### Stroke and Maximum Speed

Lead	Stroke	50~250 (every 50mm)	
		300 (mm)	755 (mm)
16	800	755	
8	400	377	
4	200	188	

(Unit: mm/s)

Code explanation ① Encoder ② Stroke ③ Applicable controller ④ Cable length ⑤ Options \*See page A-71 for details on push motion.

#### ① Encoder Type/② Stroke

② Stroke (mm)	Standard price			
	① Encoder Type			
	Incremental		Absolute	
	Motor Output (W)		Motor Output (W)	
	60W	100W	60W	100W
50	—	—	—	—
100	—	—	—	—
150	—	—	—	—
200	—	—	—	—
250	—	—	—	—
300	—	—	—	—

#### ④ Cable Length

Type	Cable symbol	Standard Price
Standard	P (1m)	—
	S (3m)	—
	M (5m)	—
Special length	X06 (6m) ~ X10 (10m)	—
	X11 (11m) ~ X15 (15m)	—
	X16 (16m) ~ X20 (20m)	—
	R01 (1m) ~ R03 (3m)	—
Robot Cable	R04 (4m) ~ R05 (5m)	—
	R06 (6m) ~ R10 (10m)	—
	R11 (11m) ~ R15 (15m)	—
	R16 (16m) ~ R20 (20m)	—

\* See page A-59 for cables for maintenance.

#### ⑤ Options

Name	Option code	See page	Standard price
Connector cable exit direction	A2	→ A-41	—
Brake	B	→ A-42	—
CE compliance	CE	→ A-42	—
Foot bracket	FT	→ A-49	—
Guide mounting direction	GS2~GS4	→ A-50	—
High acceleration/deceleration (*1)	HA	→ A-50	—

(\*1) The high-acceleration/deceleration option is not available for all 60W models and 100W model with 4mm lead.

#### Actuator Specifications

Item	Description
Drive System	Ball screw, ø12mm, rolled C10
Positioning Repeatability	±0.02mm
Lost Motion	0.1mm or less
Guide	Single guide (guide rod diameter ø10mm, ball bush type)
Rod diameter	ø30mm
Non-rotating accuracy of rod	±0.1 deg
Ambient operating temperature, humidity	0 to 40°C, 85% RH or less (Non-condensing)

Dimensional Drawings

CAD drawings can be downloaded from the website. [www.intelligentactuator.com](http://www.intelligentactuator.com)

For Special Orders Appendix P.15



\*The RGS5C is not available in non-motor end configuration, due to its construction.

(\*1) Connect the motor and encoder cables here. See page A-59 for details on cables.  
 (\*2) After homing, the slider moves to the ME, therefore, please watch for any interference with surrounding objects.  
 ME : Mechanical end SE : Stroke end

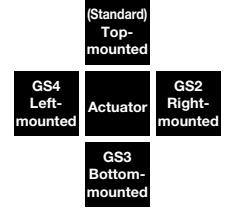
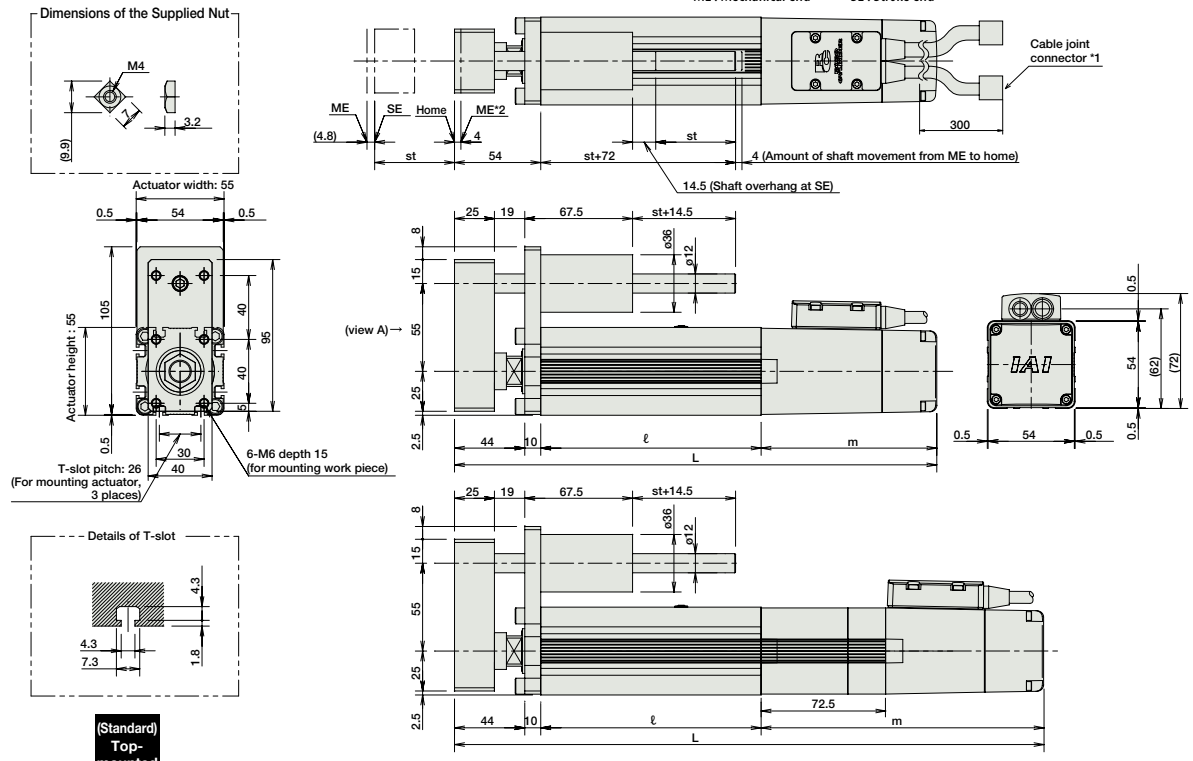

Dimensions and Weight by Stroke

RCS2-RGS5C (without brake)							RCS2-RGS5C (with brake)								
	Stroke	50	100	150	200	250	300		Stroke	50	100	150	200	250	300
L	60W	284	334	384	434	484	534	L	60W	356.5	406.5	456	506.5	556.5	606.5
	100W	302	352	402	452	502	552		100W	374.5	424.5	474.5	524.5	574.5	624.5
	ℓ	138	188	238	288	338	388		ℓ	138	188	238	288	338	388
m	60W	92						m	60W	164.5					
	100W	110							100W	182.5					
	Weight (kg)	2.5	2.8	3.2	3.6	3.9	4.3		Weight (kg)	2.8	3.1	3.5	3.9	4.2	4.6

Guide mounting direction (as viewed from view A)

Applicable Controllers

RCS2-series actuators can be operated with the following controllers. Select an appropriate controller type according to your application.

Name	External view	Model number	Features	Maximum number of positioning points	Input power	Power supply capacity	Standard price	Reference page
Positioner mode		SCON-CA-60①-NP-2-② SCON-CA-100①-NP-2-②	Up to 512 positioning points are supported.	512 points	Single-phase 100VAC Single-phase 200VAC 3-phase 200VAC (XSEL-P/Q/R/S ONLY)	314 VA max. *Power supply capacity will vary depending on the controller, so please refer to the instruction manual for details.	—	→ P643
Solenoid valve mode			Actuators can be operated through the same control used for solenoid valves.	7 points				
Field network type			Movement by numerical specification is supported.	768 points				
Pulse-train input control type			Dedicated pulse-train input type	(—)				
Positioner multi-axis, network type		MSCON-C-1-60①-V-0-② MSCON-C-1-100①-V-0-②	Up to 6 axes can be operated. Movement by numerical specification is supported.	256 points			—	→ P655
Program control type, 1 to 2 axes		SSEL-CS-1-60①-NP-2-② SSEL-CS-1-100①-NP-2-②	Program operation is supported. Up to 2 axes can be operated.	20,000 points			—	→ P685
Program control type, 1 to 8 axes		XSEL-③-1-60①-N1-EEE-2-④ XSEL-③-1-100①-N1-EEE-2-④	Program operation is supported. Up to 8 axes can be operated.	Varies depending on the number of axes connected			—	→ P695

\* This is for the single-axis MSCON, SSEL, and XSEL.  
 \* ① indicates the power-supply voltage type (1: 100V / 2: Single-phase 200V).  
 \* ② indicates the power-supply voltage type (1: 100V / 2: Single-phase 200V / 3: Three-phase 200V).  
 \* ③ indicates the encoder type (I: Incremental / A: Absolute).  
 \* ④ indicates the XSEL type (J / K / P / Q / R / S).  
 \* ⑤ indicates field network specification symbol.



# RCS2-RGS4D

Robo Cylinder, Rod Type with Single Guide, ø37mm Diameter, 200V Servo Motor, Built-In Model

Model Specification Items	<b>RCS2</b>	<b>-RGS4D</b>	<input type="checkbox"/>	<input type="checkbox"/>	<input type="checkbox"/>	<input type="checkbox"/>	<input type="checkbox"/>	<input type="checkbox"/>	<input type="checkbox"/>
	Series	Type	Encoder type	Motor type	Lead	Stroke	Applicable controller	Cable length	Options
			I: Incremental A: Absolute	20: 20W Servo motor 30: 30W Servo motor	12: 12mm 6: 6mm 3: 3mm	50: 50mm 300: 300mm (50mm pitch increments)	T1: XSEL-J/K T2: SCON MSCON SSEL XSEL-P/Q XSEL-R/S	N: None P: 1m S: 3m M: 5m X□□: Custom Length R□□: Robot Cable	See options below.

\* See page Pre-47 for details on the model descriptions.



\*CE compliance is optional.

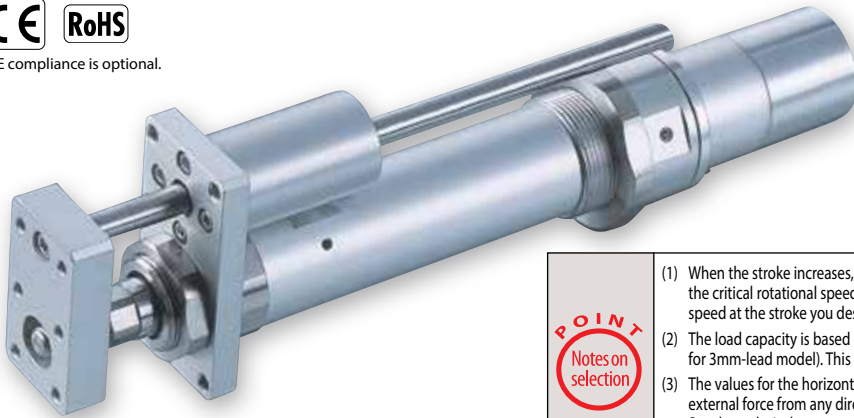

Technical References Appendix P.5

- POINT**  
Notes on selection
- When the stroke increases, the maximum speed will drop to prevent the ball screw from reaching the critical rotational speed. Use the actuator specification table below to check the maximum speed at the stroke you desire.
  - The load capacity is based on operating the standard and power-saving models at 0.3G (0.2G for 3mm-lead model). This is the upper limit of the acceleration.
  - The values for the horizontal load capacity assume the use of an external guide, so that there is no external force from any direction other than the forward/backward direction of the rod. See the technical resources (page A-111) for the allowable weight using the supplied guide alone.
  - See page A-71 for details on push motion.

### Actuator Specifications

#### Leads and Payloads

Model number	Motor output (W)	Lead (mm)	Max. Load Capacity		Rated thrust (N)	Stroke (mm)
			Horizontal (kg)	Vertical (kg)		
RCS2-RGS4D-①-20-12-②-③-④-⑤	20	12	3.0	0.5	18.9	50~300 (every 50mm)
RCS2-RGS4D-①-20-6-②-③-④-⑤		6	6.0	1.5	37.7	
RCS2-RGS4D-①-20-3-②-③-④-⑤		3	12.0	3.5	75.4	
RCS2-RGS4D-①-30-12-②-③-④-⑤	30	12	4.0	1.0	28.3	
RCS2-RGS4D-①-30-6-②-③-④-⑤		6	9.0	2.5	56.6	
RCS2-RGS4D-①-30-3-②-③-④-⑤		3	18.0	6.0	113.1	

#### Stroke and Maximum Speed

Stroke Lead	50~300 (every 50mm)	
	Stroke (mm)	Maximum Speed (mm/s)
12	600	
6	300	
3	150	

(Unit: mm/s)

Code explanation ① Encoder ② Stroke ③ Applicable controller ④ Cable length ⑤ Options \*See page A-71 for details on push motion.

#### ① Encoder Type/② Stroke

② Stroke (mm)	Standard price			
	① Encoder Type			
	Incremental		Absolute	
	Motor Output (W)		Motor Output (W)	
	20W	30W	20W	30W
50	—	—	—	—
100	—	—	—	—
150	—	—	—	—
200	—	—	—	—
250	—	—	—	—
300	—	—	—	—

#### ④ Cable Length

Type	Cable symbol	Standard Price
Standard	P (1m)	—
	S (3m)	—
	M (5m)	—
Special length	X06 (6m) ~ X10 (10m)	—
	X11 (11m) ~ X15 (15m)	—
	X16 (16m) ~ X20 (20m)	—
	R01 (1m) ~ R03 (3m)	—
Robot Cable	R04 (4m) ~ R05 (5m)	—
	R06 (6m) ~ R10 (10m)	—
	R11 (11m) ~ R15 (15m)	—
	R16 (16m) ~ R20 (20m)	—
	R16 (16m) ~ R20 (20m)	—

\* See page A-59 for cables for maintenance.

#### ⑤ Options

Name	Option code	See page	Standard price
CE compliance	CE	→ A-42	—
Foot bracket	FT	→ A-49	—
Home sensor	HS	→ A-50	—
Non-motor end specification	NM	→ A-52	—
Trunnion bracket (back)	TRR	→ A-58	—

\*The home sensor (HS) cannot be used on the non-motor end models.

#### Actuator Specifications

Item	Description
Drive System	Ball screw, ø10mm, rolled C10
Positioning Repeatability	±0.02mm
Lost Motion	0.1mm or less
Guide	Single guide (guide rod diameter ø10mm, ball bush type)
Rod diameter	ø20mm
Non-rotating accuracy of rod	±0.05 deg
Ambient operating temperature, humidity	0 to 40°C, 85% RH or less (Non-condensing)

Dimensional Drawings

CAD drawings can be downloaded from the website.

[www.intelligentactuator.com](http://www.intelligentactuator.com)

For Special Orders

Appendix P.15



- (\*1) Connect the motor and encoder cables here. See page A-59 for details on cables.
- (\*2) After homing, the slider moves to the ME, therefore, please watch for any interference with surrounding objects.  
ME : Mechanical end SE : Stroke end

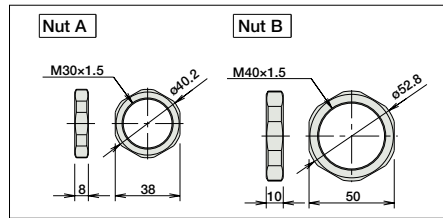
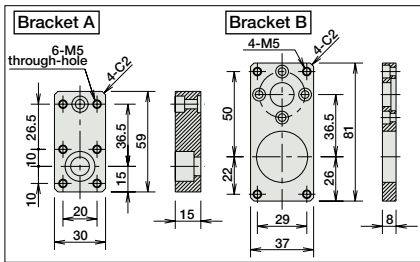
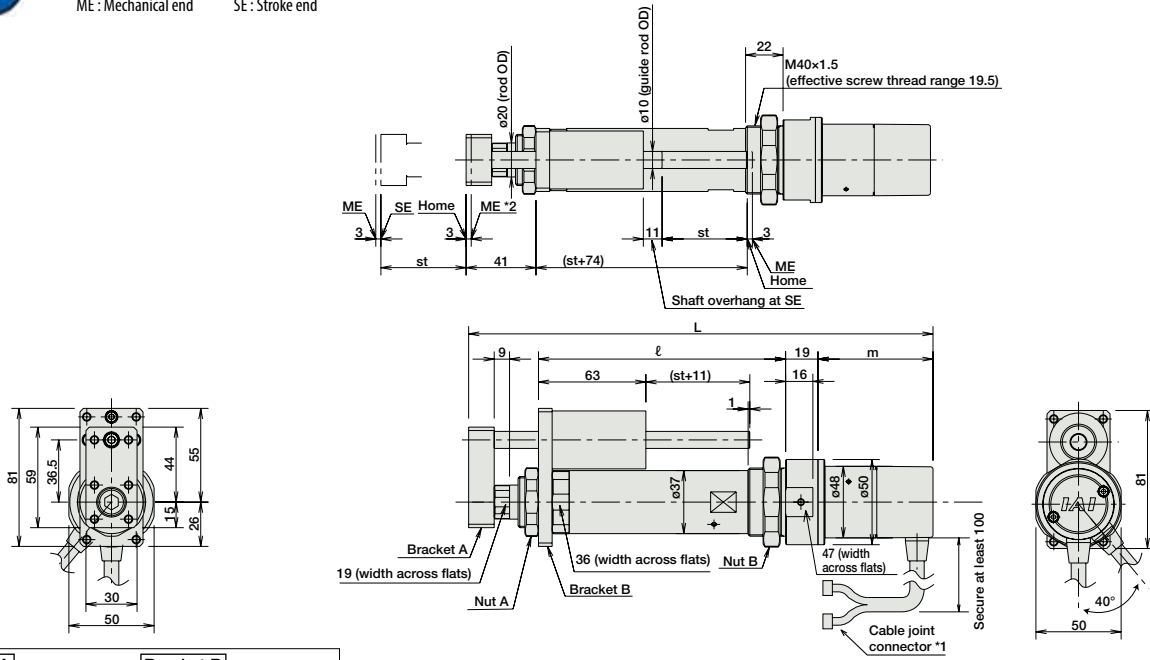

Dimensions and Weight by Stroke

RCS2-RGS4D (without brake)								
Stroke	50	100	150	200	250	300		
L	20W	263.5	313.5	363.5	413.5	463.5	513.5	
	30W	278.5	328.5	378.5	428.5	478.5	528.5	
ℓ	145	195	245	295	345	395		
		58.5						
m	20W	73.5						
	30W	73.5						
Weight (kg)	1.3	1.5	1.7	1.9	2.1	2.3		

RCS2-RGS4D models are not equipped with a brake.

Applicable Controllers

RCS2-series actuators can be operated with the following controllers. Select an appropriate controller type according to your application.

Name	External view	Model number	Features	Maximum number of positioning points	Input power	Power supply capacity	Standard price	Reference page
Positioner mode		SCON-CA-20①-NP-2-② SCON-CA-30D①-NP-2-②	Up to 512 positioning points are supported.	512 points	Single-phase 100VAC Single-phase 200VAC 3-phase 200VAC (XSEL-P/Q/R/S ONLY)	126 VA max. *Power supply capacity will vary depending on the controller, so please refer to the instruction manual for details.	—	→ P643
Solenoid valve mode			Actuators can be operated through the same control used for solenoid valves.	7 points				
Field network type			Movement by numerical specification is supported.	768 points				
Pulse-train input control type			Dedicated pulse-train input type	(—)				
Positioner multi-axis, network type		MSCON-C-1-20①-V-0-② MSCON-C-1-30D①-V-0-②	Up to 6 axes can be operated. Movement by numerical specification is supported.	256 points			—	→ P655
Program control type, 1 to 2 axes		SSEL-CS-1-20①-NP-2-② SSEL-CS-1-30D①-NP-2-②	Program operation is supported. Up to 2 axes can be operated.	20,000 points			—	→ P685
Program control type, 1 to 8 axes		XSEL-③-1-20①-N1-EEE-2-④ XSEL-③-1-30D①-N1-EEE-2-④	Program operation is supported. Up to 8 axes can be operated.	Varies depending on the number of axes connected			—	→ P695

\* This is for the single-axis MSCON, SSEL, and XSEL.  
 \* ① indicates the power-supply voltage type (1: 100V / 2: Single-phase 200V).  
 \* ② indicates the power-supply voltage type (1: 100V / 2: Single-phase 200V / 3: Three-phase 200V).  
 \* ③ indicates the encoder type (I: Incremental / A: Absolute).  
 \* ④ indicates the XSEL type (J / K / P / Q / R / S).  
 \* ⑤ indicates field network specification symbol.



# RCS2-SRGS7BD

Robo Cylinder, Rod Type with Single Guide, Actuator Width 75mm, 200V Servo Motor, Short-Length Model

Model Specification Items	<b>RCS2</b>	<b>—SRGS7BD—</b>	<b>I</b>	<input type="checkbox"/>	<input type="checkbox"/>	<input type="checkbox"/>	<input type="checkbox"/>	<input type="checkbox"/>	<input type="checkbox"/>
	Series	Type	Encoder type	Motor type	Lead	Stroke	Applicable controller	Cable length	Options
	I: Incremental	60: 60W Servo motor 100: 100W Servo motor 150: 150W Servo Motor		16: 16mm 8: 8mm 4: 4mm	50: 50mm 300: 300mm (50mm pitch increments)	T1: XSEL-J/K T2: SCON SSEL XSEL-P/Q	N: None P: 1m S: 3m M: 5m X□□: Custom Length R□□: Robot Cable	See options below.	

\* See page Pre-47 for details on the model descriptions.



Technical References Appendix P.5

- POINT**  
Notes on selection
- When operated at the rated acceleration, the maximum load capacity is the load capacity at the rated acceleration.
  - When operated at the maximum acceleration, the maximum load capacity is the load capacity at the maximum acceleration.
  - The values for the horizontal load capacity assume the use of an external guide, so that there is no external force from any direction other than the forward/backward direction of the rod. See the technical resources (page A-111) for the allowable weight using the supplied guide alone.
  - See page A-71 for details on push motion.

### Actuator Specifications

#### Leads and Payloads

Model number	Motor output (W)	Lead (mm)	Rated Acceleration (G)	Load Capacity at Rated Acceleration		Max Acceleration (G)	Load Capacity at Max. Acceleration		Rated thrust (N)	Stroke (mm)
				Horizontal (kg)	Vertical (kg)		Horizontal (kg)	Vertical (kg)		
RCS2-SRGS7BD-I-60-16-①-②-③-④	60	16	0.25	5	1.5	0.35	2.5	0.5	63	50~300 (every 50mm)
RCS2-SRGS7BD-I-60-8-①-②-③-④		8	0.15	10	4.5	0.25	5	2	127	
RCS2-SRGS7BD-I-60-4-①-②-③-④		4	0.05	20	9.5	0.15	10	4.5	254	
RCS2-SRGS7BD-I-100-16-①-②-③-④	100	16	0.3	10	3	0.4	5	1	103	
RCS2-SRGS7BD-I-100-8-①-②-③-④		8	0.2	22	8.5	0.3	10	4	207	
RCS2-SRGS7BD-I-100-4-①-②-③-④		4	0.1	40	19	0.2	20	8.5	414	
RCS2-SRGS7BD-I-150-16-①-②-③-④	150	16	0.3	15	6	0.4	7.5	2.5	157	
RCS2-SRGS7BD-I-150-8-①-②-③-④		8	0.2	35	14	0.3	17.5	6.5	314	
RCS2-SRGS7BD-I-150-4-①-②-③-④		4	0.1	55	22	0.2	27.5	10.5	628	

#### Stroke and Maximum Speed

Stroke Lead	50~300 (every 50mm)
16	800
8	400
4	200

(Unit: mm/s)

Code explanation ① Stroke ② Applicable controller ③ Cable length ④ Options \*See page A-71 for details on push motion.

#### ① Stroke

① Stroke (mm)	Standard price		
	Motor Output (W)		
	60W	100W	150W
50	—	—	—
100	—	—	—
150	—	—	—
200	—	—	—
250	—	—	—
300	—	—	—

#### ③ Cable Length

Type	Cable symbol	Standard Price
Standard	P (1m)	—
	S (3m)	—
	M (5m)	—
Special length	X06 (6m) ~ X10 (10m)	—
	X11 (11m) ~ X15 (15m)	—
	X16 (16m) ~ X20 (20m)	—
Robot Cable	R01 (1m) ~ R03 (3m)	—
	R04 (4m) ~ R05 (5m)	—
	R06 (6m) ~ R10 (10m)	—
	R11 (11m) ~ R15 (15m)	—
	R16 (16m) ~ R20 (20m)	—

\* See page A-59 for cables for maintenance.

#### ④ Options

Name	Option code	See page	Standard price
Connector cable exit direction	A1~A3	→ A-41	—
Brake	B	→ A-42	—
Foot bracket	FT	→ A-49	—
Guide mounting direction	GS2~GS4	→ A-50	—
Extended rod tip	RE	→ A-54	—

#### Actuator Specifications

Item	Description
Drive System	Ball screw, ø12mm, rolled C10
Positioning Repeatability	±0.02mm
Lost Motion	0.1mm or less
Guide	Single guide (guide rod diameter ø10mm, ball bush type)
Rod diameter	ø35mm
Non-rotating accuracy of rod	±0.1 deg
Ambient operating temperature, humidity	0 to 40°C, 85% RH or less (Non-condensing)

Dimensional Drawings

CAD drawings can be downloaded from the website. [www.intelligentactuator.com](http://www.intelligentactuator.com)

For Special Orders Appendix P.15



\*The SRGS7BD is not available in n on-motor end configuration, due to its construction.

- (\*1) Connect the motor and encoder cables here. See page A-59 for details on cables.
  - (\*2) After homing, the slider moves to the ME, therefore, please watch for any interference with surrounding objects.
- ST: Stroke  
SE : Stroke end  
ME : Mechanical end

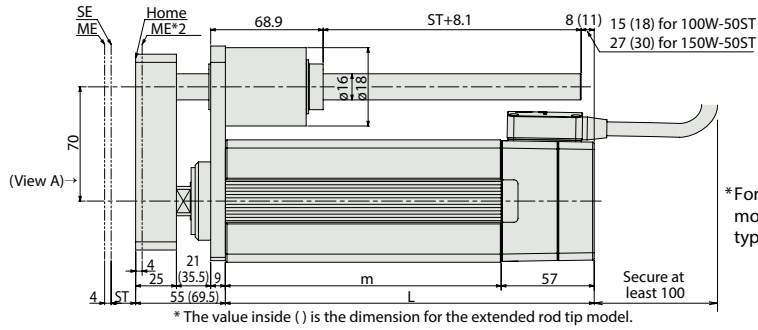
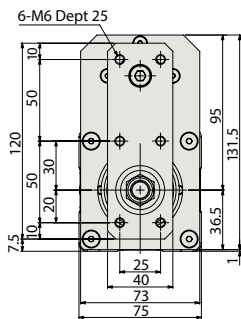

\*For brake-equipped model, see standard type (see P276)

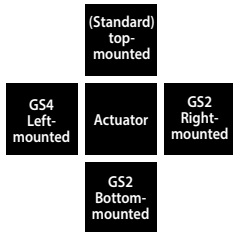

Guide mounting direction (as viewed from view A)

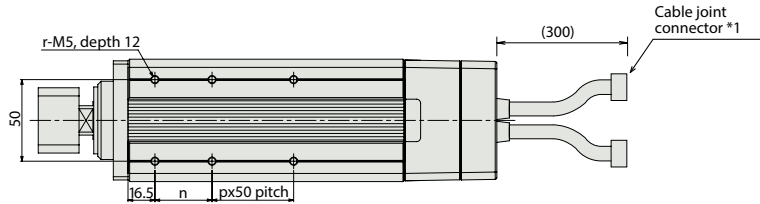

Dimensions and Weight by Stroke

Stroke		50	100	150	200	250	300
L	60W	126	176	226	276	326	376
	100W	133	176	226	276	326	376
	150W	145	176	226	276	326	376
m	60W	69	119	169	219	269	319
	100W	76	119	169	219	269	319
	150W	88	119	169	219	269	319
n		25	35	35	35	35	35
p		0	0	1	2	3	4
r		4	4	6	8	10	12
Weight (kg)	60W	3.5	4.1	4.8	5.4	6.1	6.7
	100W	3.7	4.3	4.9	5.6	6.2	6.9
	150W	4	4.5	5.1	5.8	6.4	7.1

Note:

A slit is provided in the side of the actuator body to prevent pauses due to forward/backward operation. Please make a separate request for a dustproof/splash-proof model. Please be careful when operating in the dusty environment. The dust may enter inside from the slit.

Applicable Controllers

RCS2 series actuators can be operated with the controllers indicated below. Select the type according to your intended application.

Name	External view	Model number	Features	Maximum number of positioning points	Input power	Power-supply capacity	Standard price	Reference page
Positioner mode		SCON-CA-①-I-NP-2-②	Up to 512 positioning points are supported.	512 points	Single-phase 100VAC	408 VA max.	—	→ P643
Solenoid valve mode			Actuators can be operated through the same control used for solenoid valves.	7 points				
Field network type			Movement by numerical specification is supported.	768 points				
Pulse-train input control type			Dedicated pulse-train input type	(—)				
Program control type 1 or 2 axes		SSEL-CS-1-①-I-NP-2-②	Program operation is supported Up to two axes can be operated	20,000 points	3-phase 200VAC (XSEL-P/Q only)	—	—	→ P685
Program control type 1 or 6 axes		XSEL-③-1-①-I-N1-EEE-2-④	Program operation is supported Up to six axes can be operated	20,000 points				

\* This is for the single-axis SSEL, and XSEL.

\* ① Indicates the power-supply voltage type (1: 100 V / 2: Single-phase 200 V).

\* ② Indicates the power-supply voltage type (1: 100 V / 2: Single-phase 200 V / 3: Three-phase 200 V).

\* ① Indicates the wattage (60/100/150).

\* ③ Indicates the XSEL type (J / K / P / Q).

Please note that this model cannot be connected to the XSEL-P/Q type (5-axis/6-axis), XSEL-R/S type, or MSCON.

# RCS2-RGD4C

Robo Cylinder, Rod Type with Double Guide, ø37mm Diameter, 200V Servo Motor, Coupled

Model Specification Items	<b>RCS2</b>	<b>— RGD4C</b>	<input type="checkbox"/>	<input type="checkbox"/>	<input type="checkbox"/>	<input type="checkbox"/>	<input type="checkbox"/>	<input type="checkbox"/>	<input type="checkbox"/>
	Series	Type	Encoder type	Motor type	Lead	Stroke	Applicable controller	Cable length	Options
			I: Incremental A: Absolute	20: 20W Servo motor 30: 30W Servo motor	12: 12mm 6: 6mm 3: 3mm	50: 50mm 300: 300mm (50mm pitch increments)	T1: XSEL-J/K T2: SCON MSCON SSEL XSEL-P/Q XSEL-R/S	N: None P: 1m S: 3m M: 5m X□□: Custom Length R□□: Robot Cable	See options below.

\* See page Pre-47 for details on the model descriptions.



**For High Acceleration/Deceleration**

\*CE compliance is optional. (\*1)



(\*1) Except all 20W models and 30W 3mm lead models

**Technical References** Appendix P.5



- (1) When the stroke increases, the maximum speed will drop to prevent the ball screw from reaching the critical rotational speed. Use the actuator specification table below to check the maximum speed at the stroke you desire.
- (2) The load capacity is based on operating the standard and power-saving models at 0.3G (0.2G for 3mm-lead), and 1G acceleration for the high-acceleration models (3mm-lead model excluded). (The values in the table below are the upper limits, even if the acceleration/deceleration is decreased.)
- (3) The values for the horizontal load capacity assume the use of an external guide, so that there is no external force from any direction other than the forward/backward direction of the rod. See the technical resources (page A-112) for the allowable weight using the supplied guide alone.
- (4) See page A-71 for details on push motion.

### Actuator Specifications

#### Leads and Payloads

Model number	Motor output (W)	Lead (mm)	Max. Load Capacity		Rated thrust (N)	Stroke (mm)
			Horizontal (kg)	Vertical (kg)		
RCS2-RGD4C-①-20-12-②-③-④-⑤	20	12	3.0	0.5	18.9	50~300 (every 50mm)
RCS2-RGD4C-①-20-6-②-③-④-⑤		6	6.0	1.5	37.7	
RCS2-RGD4C-①-20-3-②-③-④-⑤		3	12.0	3.5	75.4	
RCS2-RGD4C-①-30-12-②-③-④-⑤	30	12	4.0	1.0	28.3	
RCS2-RGD4C-①-30-6-②-③-④-⑤		6	9.0	2.5	56.6	
RCS2-RGD4C-①-30-3-②-③-④-⑤		3	18.0	6.0	113.1	

#### Stroke and Maximum Speed

Lead	Stroke	50~300 (every 50mm)
		12
6		300
3		150

(Unit: mm/s)

Code explanation ① Encoder ② Stroke ③ Applicable controller ④ Cable length ⑤ Options \*See page A-71 for details on push motion.

#### ① Encoder Type/② Stroke

② Stroke (mm)	Standard price			
	① Encoder Type			
	Incremental		Absolute	
	Motor Output (W)		Motor Output (W)	
	20W	30W	20W	30W
50	—	—	—	—
100	—	—	—	—
150	—	—	—	—
200	—	—	—	—
250	—	—	—	—
300	—	—	—	—

#### ④ Cable Length

Type	Cable symbol	Standard Price
Standard	P (1m)	—
	S (3m)	—
	M (5m)	—
Special length	X06 (6m) ~ X10 (10m)	—
	X11 (11m) ~ X15 (15m)	—
	X16 (16m) ~ X20 (20m)	—
	R01 (1m) ~ R03 (3m)	—
Robot Cable	R04 (4m) ~ R05 (5m)	—
	R06 (6m) ~ R10 (10m)	—
	R11 (11m) ~ R15 (15m)	—
	R16 (16m) ~ R20 (20m)	—

\* See page A-59 for cables for maintenance.

#### ⑤ Options

Name	Option code	See page	Standard price
Brake	B	→ A-42	—
CE compliance	CE	→ A-42	—
Foot bracket	FT	→ A-49	—
High-acceleration/deceleration (*1)	HA	→ A-50	—
Home sensor (*2)	HS	→ A-50	—
Non-motor end specification	NM	→ A-52	—
Trunnion bracket (back)	TRR	→ A-58	—

(\*1) The high-acceleration/deceleration option is not available for all 20W models and 30W model with 3mm lead.  
(\*2) The home sensor (HS) cannot be used on the non-motor end models.

#### Actuator Specifications

Item	Description
Drive System	Ball screw, ø10mm, rolled C10
Positioning Repeatability	±0.02mm
Lost Motion	0.1mm or less
Guide	Double guide (guide rod diameter ø10mm, ball bush type)
Rod diameter	ø20mm
Non-rotating accuracy of rod	±0.05 deg
Ambient operating temperature, humidity	0 to 40°C, 85% RH or less (Non-condensing)

- Slider Type
- Mini
- Standard
- Controller Integrated
- Rod Type
- Mini
- Standard
- Controllers Integrated
- Table/Arm/Flat Type
- Mini
- Standard
- Gripper/Rotary Type
- Linear Servo Type
- Clean-room Type
- Splash-Proof Type
- Pulse Motor
- Servo Motor (24V)
- Servo Motor (200V)
- Linear Servo Motor

Dimensional Drawings

CAD drawings can be downloaded from the website. [www.intelligentactuator.com](http://www.intelligentactuator.com)

For Special Orders Appendix P.15



(\*1) Connect the motor and encoder cables here. See page A-59 for details on cables.  
 (\*2) After homing, the slider moves to the ME, therefore, please watch for any interference with surrounding objects.  
 ME: Mechanical end SE: Stroke end

[No Brake]

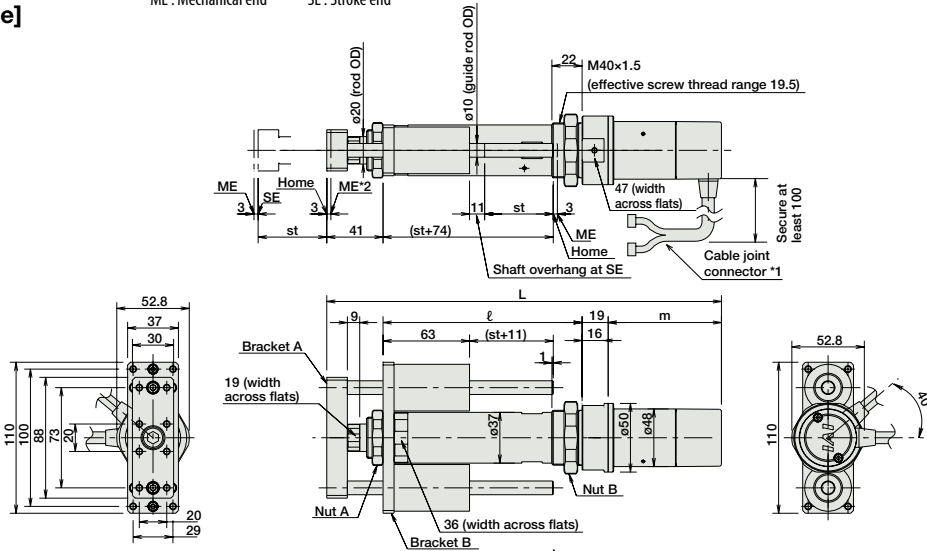

[Brake-Equipped]

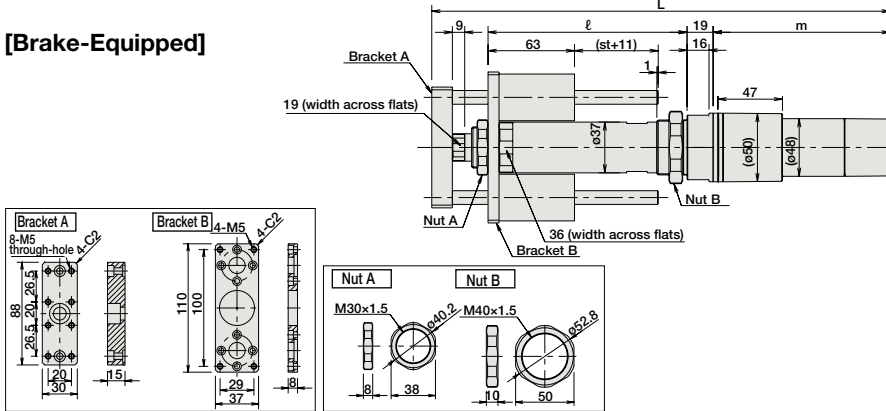

■ Dimensions and Weight by Stroke

**RCS2-RGD4C (without brake)**

		Stroke					
		50	100	150	200	250	300
L	20W	285.5	335.5	385.5	435.5	485.5	535.5
	30W	300.5	350.5	400.5	450.5	500.5	550.5
ℓ		145	195	245	295	345	395
m	20W	80.5					
	30W	95.5					
Weight (kg)		1.8	2.0	2.2	2.4	2.6	2.8

**RCS2-RGD4C (with brake)**

		Stroke					
		50	100	150	200	250	300
L	20W	328.5	378.5	428.5	478.5	528.5	578.5
	30W	343.5	393.5	443.5	493.5	543.5	593.5
ℓ		145	195	245	295	345	395
m	20W	123.5					
	30W	138.5					
Weight (kg)		2.0	2.2	2.4	2.6	2.8	3.0

③ Applicable Controllers

RCS2-series actuators can be operated with the following controllers. Select an appropriate controller type according to your application.

Name	External view	Model number	Features	Maximum number of positioning points	Input power	Power supply capacity	Standard price	Reference page
Positioner mode		SCON-CA-20①-NP-2-② SCON-CA-30D①-NP-2-②	Up to 512 positioning points are supported.	512 points	Single-phase 100VAC Single-phase 200VAC 3-phase 200VAC (XSEL-P/Q/R/S ONLY)	126 VA max. *Power supply capacity will vary depending on the controller, so please refer to the instruction manual for details.	—	→ P643
Solenoid valve mode			Actuators can be operated through the same control used for solenoid valves.	7 points				
Field network type			Movement by numerical specification is supported.	768 points				
Pulse-train input control type			Dedicated pulse-train input type	(—)				
Positioner multi-axis, network type		MSCON-C-1-20①-V-0-② MSCON-C-1-30D①-V-0-②	Up to 6 axes can be operated. Movement by numerical specification is supported.	256 points	—	—	→ P655	
Program control type, 1 to 2 axes		SSEL-CS-1-20①-NP-2-② SSEL-CS-1-30D①-NP-2-②	Program operation is supported. Up to 2 axes can be operated.	20,000 points				→ P685
Program control type, 1 to 8 axes		XSEL-③-1-20①-N1-EEE-2-④ XSEL-③-1-30D①-N1-EEE-2-④	Program operation is supported. Up to 8 axes can be operated.	Varies depending on the number of axes connected				

\* This is for the single-axis MSCON, SSEL, and XSEL.  
 \* ① indicates the power-supply voltage type (1: 100V / 2: Single-phase 200V).  
 \* ② indicates the power-supply voltage type (1: 100V / 2: Single-phase 200V / 3: Three-phase 200V).  
 \* ③ indicates the encoder type (I: Incremental / A: Absolute).  
 \* ④ indicates the XSEL type (J / K / P / Q / R / S).  
 \* ⑤ indicates field network specification symbol.

# RCS2-RGD5C

Robo Cylinder, Rod Type with Double Guide, Actuator Width 55mm, 200V Servo Motor, Coupled

Model Specification Items	<b>RCS2</b>	<b>— RGD5C</b>	—	—	—	—	—	—	—
	Series	Type	Encoder type	Motor type	Lead	Stroke	Applicable controller	Cable length	Options
	I: Incremental A: Absolute	60: 60W Servo motor 100: 100W Servo motor	16: 16mm 8: 8mm 4: 4mm	50: 50mm 300: 300mm (50mm pitch increments)	T1: XSEL-J/K T2: SCON MSCON SSEL XSEL-P/Q XSEL-R/S	N: None P: 1m S: 3m M: 5m X□□: Custom Length R□□: Robot Cable	See options below.		

\* See page Pre-47 for details on the model descriptions.



**For High Acceleration/Deceleration**

(\*1)

\*CE compliance is optional.



(\*1) Except all 60W models and 100W 4mm lead models

**Technical References** Appendix P.5

- POINT**  
Notes on selection
- (1) When the stroke increases, the maximum speed will drop to prevent the ball screw from reaching the critical rotational speed. Use the actuator specification table below to check the maximum speed at the stroke you desire.
  - (2) The load capacity is based on operating the standard and power-saving models at 0.3G (0.2G for 4mm-lead), and 1G acceleration for the high-acceleration models (4mm-lead model excluded). (The values in the table below are the upper limits, even if the acceleration/deceleration is decreased.)
  - (3) The values for the horizontal load capacity assume the use of an external guide, so that there is no external force from any direction other than the forward/backward direction of the rod. See the technical resources (page A-112) for the allowable weight using the supplied guide alone.
  - (4) See page A-71 for details on push motion.

**Actuator Specifications**

**Leads and Payloads**

Model number	Motor output (W)	Lead (mm)	Max. Load Capacity		Rated thrust (N)	Stroke (mm)
			Horizontal (kg)	Vertical (kg)		
RCS2-RGD5C-①-60-16-②-③-④-⑤	60	16	12.0	1.3	63.8	50~300 (every 50mm)
RCS2-RGD5C-①-60-8-②-③-④-⑤		8	25.0	4.3	127.5	
RCS2-RGD5C-①-60-4-②-③-④-⑤		4	50.0	10.8	255.1	
RCS2-RGD5C-①-100-16-②-③-④-⑤	100	16	15.0	2.8	105.8	
RCS2-RGD5C-①-100-8-②-③-④-⑤		8	30.0	8.3	212.7	
RCS2-RGD5C-①-100-4-②-③-④-⑤		4	60.0	17.3	424.3	

**Stroke and Maximum Speed**

Lead	Stroke	50~250 (every 50mm)	300 (mm)
	16	800	755
8	400	377	
4	200	188	

(Unit: mm/s)

Code explanation ① Encoder ② Stroke ③ Applicable controller ④ Cable length ⑤ Options \*See page A-71 for details on push motion.

**① Encoder Type/② Stroke**

② Stroke (mm)	Standard price			
	① Encoder Type			
	Incremental		Absolute	
	Motor Output (W)	Motor Output (W)	Motor Output (W)	Motor Output (W)
	<b>60W</b>	<b>100W</b>	<b>60W</b>	<b>100W</b>
50	—	—	—	—
100	—	—	—	—
150	—	—	—	—
200	—	—	—	—
250	—	—	—	—
300	—	—	—	—

**④ Cable Length**

Type	Cable symbol	Standard Price
Standard	<b>P</b> (1m)	—
	<b>S</b> (3m)	—
	<b>M</b> (5m)	—
Special length	<b>X06</b> (6m) ~ <b>X10</b> (10m)	—
	<b>X11</b> (11m) ~ <b>X15</b> (15m)	—
	<b>X16</b> (16m) ~ <b>X20</b> (20m)	—
Robot Cable	<b>R01</b> (1m) ~ <b>R03</b> (3m)	—
	<b>R04</b> (4m) ~ <b>R05</b> (5m)	—
	<b>R06</b> (6m) ~ <b>R10</b> (10m)	—
	<b>R11</b> (11m) ~ <b>R15</b> (15m)	—
	<b>R16</b> (16m) ~ <b>R20</b> (20m)	—

\* See page A-59 for cables for maintenance.

**⑤ Options**

Name	Option code	See page	Standard price
Connector cable exit direction	<b>A2</b>	→ A-41	—
Brake	<b>B</b>	→ A-42	—
CE compliance	<b>CE</b>	→ A-42	—
Foot bracket	<b>FT</b>	→ A-49	—
High acceleration/deceleration (*1)	<b>HA</b>	→ A-50	—

(\*1) The high-acceleration/deceleration option is not available for all 60W models and 100W model with 4mm lead.

**Actuator Specifications**

Item	Description
Drive System	Ball screw, ø12mm, rolled C10
Positioning Repeatability	±0.02mm
Lost Motion	0.1mm or less
Guide	Double guide (guide rod diameter ø12mm, ball bush type)
Rod diameter	ø30mm
Non-rotating accuracy of rod	±0.08 deg
Ambient operating temperature, humidity	0 to 40°C, 85% RH or less (Non-condensing)

Dimensional Drawings

CAD drawings can be downloaded from the website. [www.intelligentactuator.com](http://www.intelligentactuator.com)

For Special Orders Appendix P.15



\*The RGD5C is not available in non-motor end configuration, due to its construction.

(\*1) Connect the motor and encoder cables here. See page A-59 for details on cables.  
 (\*2) After homing, the slider moves to the ME, therefore, please watch for any interference with surrounding objects.  
 ME : Mechanical end SE : Stroke end

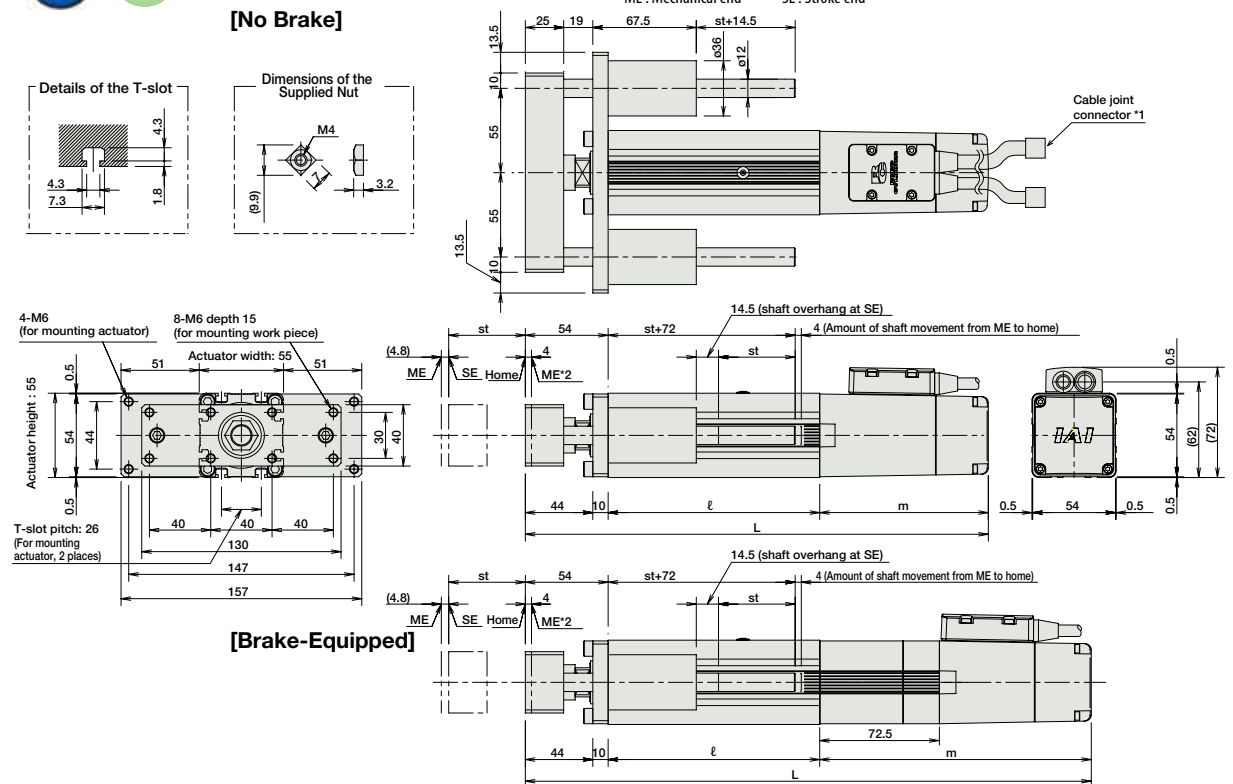

Dimensions and Weight by Stroke

RCS2-RGD5C (without brake)							RCS2-RGD5C (with brake)								
	Stroke	50	100	150	200	250	300		Stroke	50	100	150	200	250	300
L	60W	284	334	384	434	484	524	L	60W	356.5	406.5	456.5	506.5	556.5	606.5
	100W	302	352	402	452	502	552		100W	374.5	424.5	474.5	524.5	574.5	624.5
	l	138	188	238	288	338	388		l	138	188	238	288	338	388
m	60W	92					m	60W	164.5						
	100W	110						100W	182.5						
	Weight (kg)	2.7	3.0	3.4	3.8	4.2	5.5		Weight (kg)	3.0	3.3	3.7	4.1	4.5	5.8

Applicable Controllers

RCS2-series actuators can be operated with the following controllers. Select an appropriate controller type according to your application.

Name	External view	Model number	Features	Maximum number of positioning points	Input power	Power supply capacity	Standard price	Reference page
Positioner mode		SCON-CA-60①-NP-2-② SCON-CA-100①-NP-2-②	Up to 512 positioning points are supported.	512 points	Single-phase 100VAC Single-phase 200VAC 3-phase 200VAC (XSEL-P/Q/R/S ONLY)	314 VA max. *Power supply capacity will vary depending on the controller, so please refer to the instruction manual for details.	—	→ P643
Solenoid valve mode			Actuators can be operated through the same control used for solenoid valves.	7 points				
Field network type			Movement by numerical specification is supported.	768 points				
Pulse-train input control type			Dedicated pulse-train input type	(—)				
Positioner multi-axis, network type		MSON-C-1-60①-V-0-② MSON-C-1-100①-V-0-②	Up to 6 axes can be operated. Movement by numerical specification is supported.	256 points			—	→ P655
Program control type, 1 to 2 axes		SSEL-CS-1-60①-NP-2-② SSEL-CS-1-100①-NP-2-②	Program operation is supported. Up to 2 axes can be operated.	20,000 points			—	→ P685
Program control type, 1 to 8 axes		XSEL-③-1-60①-N1-EEE-2-④ XSEL-③-1-100①-N1-EEE-2-④	Program operation is supported. Up to 8 axes can be operated.	Varies depending on the number of axes connected			—	→ P695

\* This is for the single-axis MSON, SSEL, and XSEL.  
 \* ① indicates the power-supply voltage type (1: 100V / 2: Single-phase 200V).  
 \* ② indicates the power-supply voltage type (1: 100V / 2: Single-phase 200V / 3: Three-phase 200V).  
 \* ③ indicates the encoder type (I: Incremental / A: Absolute).  
 \* ④ indicates the XSEL type (J / K / P / Q / R / S).  
 \* ⑤ indicates field network specification symbol.



# RCS2-RGD4D

Robo Cylinder, Rod Type with Double Guide, ø37mm Diameter, 200V Servo Motor, Built-In Model

Model Specification Items	<b>RCS2</b>	<b>— RGD4D</b>	<input type="checkbox"/>	<input type="checkbox"/>	<input type="checkbox"/>	<input type="checkbox"/>	<input type="checkbox"/>	<input type="checkbox"/>	<input type="checkbox"/>
	Series	Type	Encoder type	Motor type	Lead	Stroke	Applicable controller	Cable length	Options
			I : Incremental A : Absolute	20 : 20W Servo motor 30 : 30W Servo motor	12 : 12mm 6 : 6mm 3 : 3mm	50: 50mm 300: 300mm (50mm pitch increments)	T1: XSEL-J/K T2: SCON MSCON SSEL XSEL-P/Q XSEL-R/S	N: None P: 1m S: 3m M: 5m X□□: Custom Length R□□: Robot Cable	See options below.

\* See page Pre-47 for details on the model descriptions.



\*CE compliance is optional.

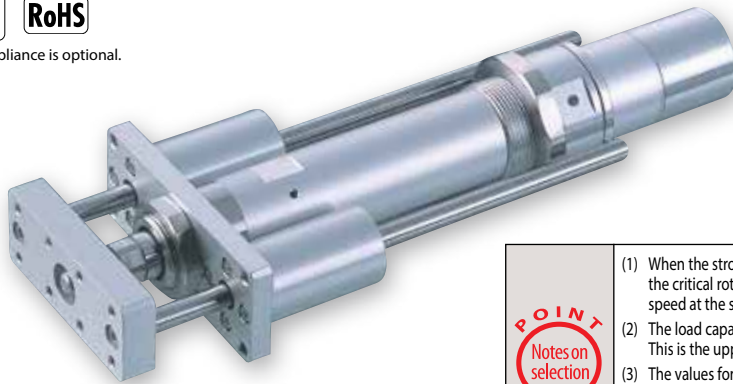

Technical References Appendix P.5

- POINT**  
Notes on selection
- When the stroke increases, the maximum speed will drop to prevent the ball screw from reaching the critical rotational speed. Use the actuator specification table below to check the maximum speed at the stroke you desire.
  - The load capacity is based on operation at an acceleration of 0.3G (0.2G for the 3mm-lead model). This is the upper limit of the acceleration.
  - The values for the horizontal load capacity assume the use of an external guide, so that there is no external force from any direction other than the forward/backward direction of the rod. See the technical resources (page A-112) for the allowable weight using the supplied guide alone.
  - See page A-71 for details on push motion.

### Actuator Specifications

#### Leads and Payloads

Model number	Motor output (W)	Lead (mm)	Max. Load Capacity		Rated thrust (N)	Stroke (mm)
			Horizontal (kg)	Vertical (kg)		
RCS2-RGD4D-①-20-12-②-③-④-⑤	20	12	3.0	0.5	18.9	50~300 (every 50mm)
RCS2-RGD4D-①-20-6-②-③-④-⑤		6	6.0	1.5	37.7	
RCS2-RGD4D-①-20-3-②-③-④-⑤		3	12.0	3.5	75.4	
RCS2-RGD4D-①-30-12-②-③-④-⑤	30	12	4.0	1.0	28.3	
RCS2-RGD4D-①-30-6-②-③-④-⑤		6	9.0	2.5	56.6	
RCS2-RGD4D-①-30-3-②-③-④-⑤		3	18.0	6.0	113.1	

#### Stroke and Maximum Speed

Stroke	50~300 (every 50mm)	
	Lead	Stroke
12	12	600
6	6	300
3	3	150

(Unit: mm/s)

Code explanation ① Encoder ② Stroke ③ Applicable controller ④ Cable length ⑤ Options \*See page A-71 for details on push motion.

#### ① Encoder Type/② Stroke

② Stroke (mm)	Standard price			
	① Encoder Type			
	Incremental		Absolute	
	Motor Output (W)		Motor Output (W)	
	20W	30W	20W	30W
50	—	—	—	—
100	—	—	—	—
150	—	—	—	—
200	—	—	—	—
250	—	—	—	—
300	—	—	—	—

#### ④ Cable Length

Type	Cable symbol	Standard Price
Standard	P (1m)	—
	S (3m)	—
	M (5m)	—
Special length	X06 (6m) ~ X10 (10m)	—
	X11 (11m) ~ X15 (15m)	—
	X16 (16m) ~ X20 (20m)	—
Robot Cable	R01 (1m) ~ R03 (3m)	—
	R04 (4m) ~ R05 (5m)	—
	R06 (6m) ~ R10 (10m)	—
	R11 (11m) ~ R15 (15m)	—
	R16 (16m) ~ R20 (20m)	—

\* See page A-59 for cables for maintenance.

#### ⑤ Options

Name	Option code	See page	Standard price
CE compliance	CE	→ A-42	—
Foot bracket	FT	→ A-49	—
Home sensor	HS	→ A-50	—
Non-motor end specification	NM	→ A-52	—
Trunnion bracket (back)	TRR	→ A-58	—

\*The home sensor (HS) cannot be used on the non-motor end models.

#### Actuator Specifications

Item	Description
Drive System	Ball screw, ø10mm, rolled C10
Positioning Repeatability	±0.02mm
Lost Motion	0.1mm or less
Guide	Double guide (guide rod diameter ø10mm, ball bush type)
Rod diameter	ø20mm
Non-rotating accuracy of rod	±0.05 deg
Ambient operating temperature, humidity	0 to 40°C, 85% RH or less (Non-condensing)

Dimensional Drawings

CAD drawings can be downloaded from the website. [www.intelligentactuator.com](http://www.intelligentactuator.com)

For Special Orders Appendix P.15



- (\*1) Connect the motor and encoder cables here. See page A-59 for details on cables.
  - (\*2) After homing, the slider moves to the ME, therefore, please watch for any interference with surrounding objects.
- ME: Mechanical end SE: Stroke end

[No Brake]

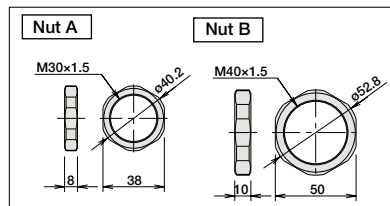
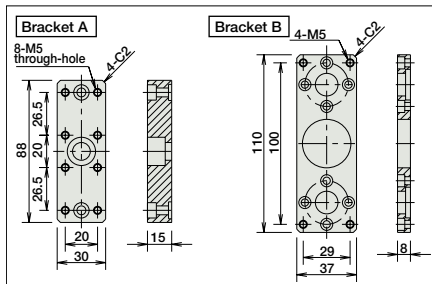
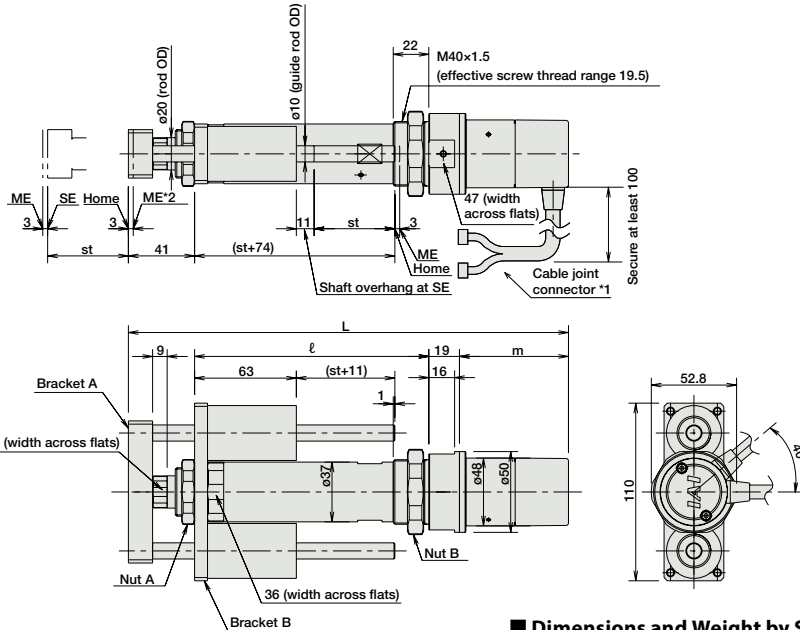

Dimensions and Weight by Stroke

RCS2-RGD4D (without brake)							
Stroke	50	100	150	200	250	300	
L	20W	263.5	313.5	363.5	413.5	463.5	513.5
	30W	278.5	328.5	378.5	428.5	478.5	528.5
ℓ	20W	145	195	245	295	345	395
	30W						
m	20W	58.5					
	30W	73.5					
Weight (kg)	1.6	1.8	2.1	2.3	2.5	2.7	

RCS2-RGD4D models are not equipped with a brake.

Applicable Controllers

RCS2-series actuators can be operated with the following controllers. Select an appropriate controller type according to your application.

Name	External view	Model number	Features	Maximum number of positioning points	Input power	Power supply capacity	Standard price	Reference page
Positioner mode		SCON-CA-20①-NP-2-② SCON-CA-30D①-NP-2-②	Up to 512 positioning points are supported.	512 points	Single-phase 100VAC Single-phase 200VAC 3-phase 200VAC (XSEL-P/Q/R/S ONLY)	126 VA max. *Power supply capacity will vary depending on the controller, so please refer to the instruction manual for details.	—	→ P643
Solenoid valve mode			Actuators can be operated through the same control used for solenoid valves.	7 points				
Field network type			Movement by numerical specification is supported.	768 points				
Pulse-train input control type			Dedicated pulse-train input type	(—)				
Positioner multi-axis, network type		MSCON-C-1-20①-V-0-② MSCON-C-1-30D①-V-0-②	Up to 6 axes can be operated. Movement by numerical specification is supported.	256 points			—	→ P655
Program control type, 1 to 2 axes		SSEL-CS-1-20①-NP-2-② SSEL-CS-1-30D①-NP-2-②	Program operation is supported. Up to 2 axes can be operated.	20,000 points			—	→ P685
Program control type, 1 to 8 axes		XSEL-③-1-20①-N1-EEE-2-④ XSEL-③-1-30D①-N1-EEE-2-④	Program operation is supported. Up to 8 axes can be operated.	Varies depending on the number of axes connected			—	→ P695

\* This is for the single-axis MSCON, SSEL, and XSEL.  
 ① indicates the power-supply voltage type (1: 100V / 2: Single-phase 200V).  
 ② indicates the power-supply voltage type (1: 100V / 2: Single-phase 200V / 3: Three-phase 200V).  
 ③ indicates the encoder type (I: Incremental / A: Absolute).  
 ④ indicates the XSEL type (J / K / P / Q / R / S).  
 \* indicates field network specification symbol.



# RCS2-SRGD7BD

Robo Cylinder, Rod Type with Double Guide, Actuator Width 75mm, 200V Servo Motor, Short-Length Model

Model Specification Items	<b>RCS2</b>	<b>—SRGD7BD—</b>	<b>I</b>	<input type="checkbox"/>	<input type="checkbox"/>	<input type="checkbox"/>	<input type="checkbox"/>	<input type="checkbox"/>	<input type="checkbox"/>
	Series	Type	Encoder type	Motor type	Lead	Stroke	Applicable controller	Cable length	Options
	I: Incremental	60: 60W Servo motor 100: 100W Servo motor 150: 150W Servo motor		16: 16mm 8: 8mm 4: 4mm	50: 50mm 300: 300mm (50mm pitch increments)	T1: XSEL-J/K T2: SCON SSEL XSEL-P/Q	N: None P: 1m S: 3m M: 5m X <input type="checkbox"/> : Custom Length R <input type="checkbox"/> : Robot Cable	See options below.	

\* See page Pre-47 for details on the model descriptions.

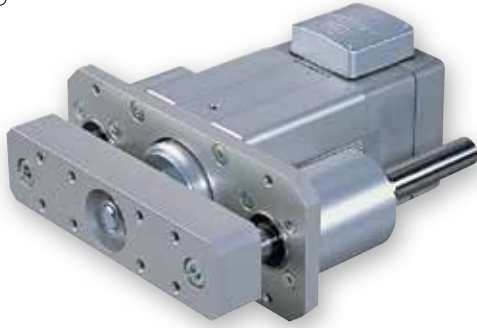

Technical References Appendix P.5

- POINT**  
Notes on selection
- When operated at the rated acceleration, the maximum load capacity is the load capacity at the rated acceleration.
  - When operated at the maximum acceleration, the maximum load capacity is the load capacity at the maximum acceleration.
  - The values for the horizontal load capacity assume the use of an external guide, so that there is no external force from any direction other than the forward/backward direction of the rod. See the technical resources (page A-112) for the allowable weight using the supplied guide alone.
  - See page A-71 for details on push motion.

### Actuator Specifications

#### Leads and Payloads

Model number	Motor output (W)	Lead (mm)	Rated Acceleration (G)	Load Capacity at Rated Acceleration		Max Acceleration (G)	Load Capacity at Max. Acceleration		Rated thrust (N)	Stroke (mm)
				Horizontal (kg)	Vertical (kg)		Horizontal (kg)	Vertical (kg)		
RCS2-SRGD7BD-I-60-16-①-②-③-④	60	16	0.25	5	1	0.35	2.5	(N/A)	63	50~300 (every 50mm)
RCS2-SRGD7BD-I-60-8-①-②-③-④		8	0.15	10	4	0.25	5	1.5	127	
RCS2-SRGD7BD-I-60-4-①-②-③-④		4	0.05	20	9	0.15	10	4	254	
RCS2-SRGD7BD-I-100-16-①-②-③-④	100	16	0.3	10	2.5	0.4	5	0.5	103	
RCS2-SRGD7BD-I-100-8-①-②-③-④		8	0.2	22	8	0.3	10	3.5	207	
RCS2-SRGD7BD-I-100-4-①-②-③-④		4	0.1	40	18.5	0.2	20	8	414	
RCS2-SRGD7BD-I-150-16-①-②-③-④	150	16	0.3	15	5.5	0.4	7.5	2	157	
RCS2-SRGD7BD-I-150-8-①-②-③-④		8	0.2	35	13.5	0.3	17.5	6	314	
RCS2-SRGD7BD-I-150-4-①-②-③-④		4	0.1	55	21.5	0.2	27.5	10	628	

#### Stroke and Maximum Speed

Stroke Lead	50~300 (every 50mm)
16	800
8	400
4	200

(Unit: mm/s)

Code explanation ① Stroke ② Applicable controller ③ Cable length ④ Options \*See page A-71 for details on push motion.

#### ① Stroke

① Stroke (mm)	Standard price		
	Motor Output (W)		
	60W	100W	150W
50	—	—	—
100	—	—	—
150	—	—	—
200	—	—	—
250	—	—	—
300	—	—	—

#### ③ Cable Length

Type	Cable symbol	Standard Price
Standard	P (1m)	—
	S (3m)	—
	M (5m)	—
Special length	X06 (6m) ~ X10 (10m)	—
	X11 (11m) ~ X15 (15m)	—
	X16 (16m) ~ X20 (20m)	—
Robot Cable	R01 (1m) ~ R03 (3m)	—
	R04 (4m) ~ R05 (5m)	—
	R06 (6m) ~ R10 (10m)	—
	R11 (11m) ~ R15 (15m)	—
	R16 (16m) ~ R20 (20m)	—

\* See page A-59 for cables for maintenance.

#### ④ Options

Name	Option code	See page	Standard price
Connector cable exit direction	A1~A3	→ A-41	—
Brake	B	→ A-42	—
Foot bracket	FT	→ A-49	—
Guide mounting direction	GS2~GS4	→ A-50	—
Extended rod tip	RE	→ A-54	—

#### Actuator Specifications

Item	Description
Drive System	Ball screw, ø12mm, rolled C10
Positioning Repeatability	±0.02mm
Lost Motion	0.1mm or less
Guide	Double guide (guide rod diameter ø16mm, ball bush type)
Rod diameter	ø35mm
Non-rotating accuracy of rod	±0.08 deg
Ambient operating temperature, humidity	0 to 40°C, 85% RH or less (Non-condensing)

Dimensional Drawings

CAD drawings can be downloaded from the website. [www.intelligentactuator.com](http://www.intelligentactuator.com)

For Special Orders Appendix P.15



\*The SRGD7BD is not available in non-motor end configuration, due to its construction.

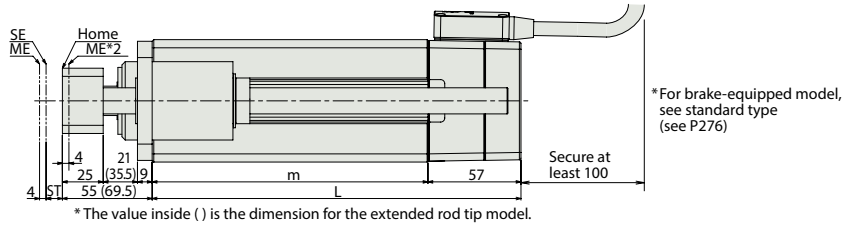
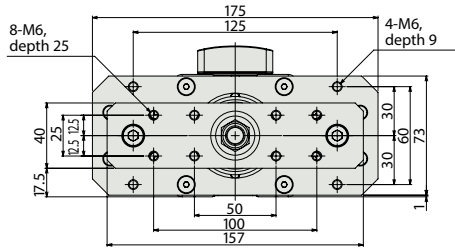

Note:  
A slit is provided in the side of the actuator body to prevent pauses due to forward/backward operation. Please make a separate request for a dustproof/splash-proof model.  
Please be careful when operating in the dusty environment. The dust may enter inside from the slit.

- (\*1) Connect the motor and encoder cables here. See page A-59 for details on cables.
- (\*2) After homing, the slider moves to the ME, therefore, please watch for any interference with surrounding objects.  
ST: Stroke  
SE: Stroke end  
ME: Mechanical end

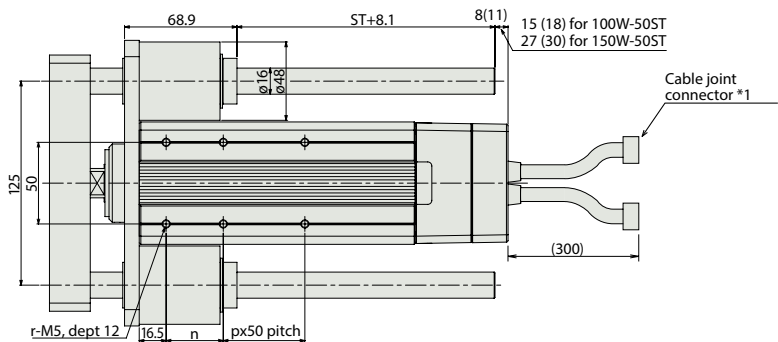

Dimensions and Weight by Stroke

Stroke		50	100	150	200	250	300
L	60W	126	176	226	276	326	376
	100W	133	176	226	276	326	376
	150W	145	176	226	276	326	376
m	60W	69	119	169	219	269	319
	100W	76	119	169	219	269	319
	150W	88	119	169	219	269	319
n		25	35	35	35	35	35
p		0	0	1	2	3	4
r		4	4	6	8	10	12
Weight (kg)	60W	4.3	5	5.7	6.4	7.2	7.9
	100W	4.5	5.1	5.9	6.6	7.3	8
	150W	4.8	5.3	6.1	6.8	7.5	8.2

Applicable Controllers

RCS2 series actuators can be operated with the controllers indicated below. Select the type according to your intended application.

Name	External view	Model number	Features	Maximum number of positioning points	Input power	Power-supply capacity	Standard price	Reference page
Positioner mode		SCON-CA-①I-NP-2-②	Up to 512 positioning points are supported.	512 points	Single-phase 100VAC	408 VA max.	—	→ P643
Solenoid valve mode			Actuators can be operated through the same control used for solenoid valves.	7 points				
Field network type			Movement by numerical specification is supported.	768 points				
Pulse-train input control type			Dedicated pulse-train input type	(—)				
Program control type 1 or 2 axes		SSEL-CS-1-①I-NP-2-②	Program operation is supported Up to two axes can be operated	20,000 points	3-phase 200VAC (XSEL-P/Q only)	—	—	→ P685
Program control type 1 or 6 axes		XSEL-③-1-①I-N1-EEE-2-④	Program operation is supported Up to six axes can be operated	20,000 points				

\* This is for the single-axis SSEL, and XSEL.  
 \* ① Indicates the power-supply voltage type (1: 100 V / 2: Single-phase 200 V).  
 \* ② Indicates the power-supply voltage type (1: 100 V / 2: Single-phase 200 V / 3: Three-phase 200 V).  
 \* ③ Indicates the wattage (60/100/150).  
 \* ④ Indicates the XSEL type (J / K / P / Q).

Please note that this model cannot be connected to the XSEL-P/Q type (5-axis/6-axis), XSEL-R/S type, or MSCON.

- Slider Type
- Mini
- Standard
- Controller Integrated
- Rod Type
- Mini
- Standard
- Controllers Integrated
- Table/ Arm/ Flat Type
- Mini
- Standard
- Gripper/ Rotary Type
- Linear Servo Type
- Clean-room Type
- Splash-Proof Type
- Pulse Motor
- Servo Motor (24V)
- Servo Motor (200V)
- Linear Servo Motor

# RCS2-RGD4R

Robo Cylinder, Rod Type with Double Guide, ø37mm Diameter, 200V Servo Motor, Side-mounted Motor

Model Specification Items	<b>RCS2</b>	<b>— RGD4R</b>	<input type="checkbox"/>	<input type="checkbox"/>	<input type="checkbox"/>	<input type="checkbox"/>	<input type="checkbox"/>	<input type="checkbox"/>	<input type="checkbox"/>
	Series	Type	Encoder type	Motor type	Lead	Stroke	Applicable controller	Cable length	Options
			I: Incremental A: Absolute	20: 20W Servo motor 30: 30W Servo motor	12: 12mm 6: 6mm 3: 3mm	50: 50mm ? 300: 300mm (50mm pitch increments)	T1: XSEL-J/K T2: SCON MSCON SSEL XSEL-P/Q XSEL-R/S	N: None P: 1m S: 3m M: 5m X□□: Custom Length R□□: Robot Cable	See options below.

\* See page Pre-47 for details on the model descriptions.



\*CE compliance is optional.

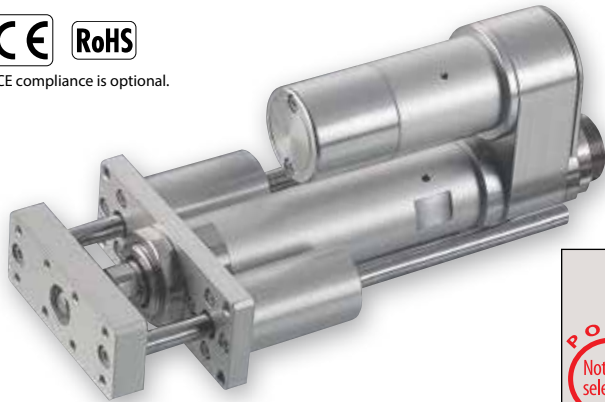

Technical References Appendix P.5

- POINT**  
Notes on selection
- When the stroke increases, the maximum speed will drop to prevent the ball screw from reaching the critical rotational speed. Use the actuator specification table below to check the maximum speed at the stroke you desire.
  - The load capacity is based on operation at an acceleration of 0.3G (0.2G for the 3mm-lead model). This is the upper limit of the acceleration.
  - The values for the horizontal load capacity assume the use of an external guide, so that there is no external force from any direction other than the forward/backward direction of the rod. See the technical resources (page A-112) for the allowable weight using the supplied guide alone.
  - See page A-71 for details on push motion.

### Actuator Specifications

#### Leads and Payloads

Model number	Motor output (W)	Lead (mm)	Max. Load Capacity		Rated thrust (N)	Stroke (mm)
			Horizontal (kg)	Vertical (kg)		
RCS2-RGD4R-①-20-12-②-③-④-⑤	20	12	3.0	0.5	18.9	50~300 (every 50mm)
RCS2-RGD4R-①-20-6-②-③-④-⑤		6	6.0	1.5	37.7	
RCS2-RGD4R-①-20-3-②-③-④-⑤		3	12.0	3.5	75.4	
RCS2-RGD4R-①-30-12-②-③-④-⑤	30	12	4.0	1.0	28.3	
RCS2-RGD4R-①-30-6-②-③-④-⑤		6	9.0	2.5	56.6	
RCS2-RGD4R-①-30-3-②-③-④-⑤		3	18.0	6.0	113.1	

#### Stroke and Maximum Speed

Stroke	50~300 (every 50mm)
12	600
6	300
3	150

(Unit: mm/s)

Code explanation ① Encoder ② Stroke ③ Applicable controller ④ Cable length ⑤ Options \*See page A-71 for details on push motion.

#### ① Encoder Type/② Stroke

② Stroke (mm)	Standard price			
	① Encoder Type			
	Incremental		Absolute	
	Motor Output (W)		Motor Output (W)	
	20W	30W	20W	30W
50	—	—	—	—
100	—	—	—	—
150	—	—	—	—
200	—	—	—	—
250	—	—	—	—
300	—	—	—	—

#### ④ Cable Length

Type	Cable symbol	Standard Price
Standard	P (1m)	—
	S (3m)	—
	M (5m)	—
Special length	X06 (6m) ~ X10 (10m)	—
	X11 (11m) ~ X15 (15m)	—
	X16 (16m) ~ X20 (20m)	—
Robot Cable	R01 (1m) ~ R03 (3m)	—
	R04 (4m) ~ R05 (5m)	—
	R06 (6m) ~ R10 (10m)	—
	R11 (11m) ~ R15 (15m)	—
	R16 (16m) ~ R20 (20m)	—

\* See page A-59 for cables for maintenance.

#### ⑤ Options

Name	Option code	See page	Standard price
Brake	B	→ A-42	—
CE compliance	CE	→ A-42	—
Foot bracket	FT	→ A-49	—
Flange bracket (back)	FLR	→ A-46	—
Home sensor	HS	→ A-50	—
Non-motor end specification	NM	→ A-52	—
Clevis bracket	QR	→ A-53	—
Back-mounting plate	RP	→ A-54	—

\*The home sensor (HS) cannot be used on the non-motor end models.

#### Actuator Specifications

Item	Description
Drive System	Ball screw, ø10mm, rolled C10
Positioning Repeatability	±0.02mm
Lost Motion	0.1mm or less
Base	Material: Aluminum, white alumite treated
Rod diameter	ø20mm
Non-rotating accuracy of rod	±0.05 deg
Ambient operating temperature, humidity	0 to 40°C, 85% RH or less (Non-condensing)

299 RCS2-RGD4R

## Dimensional Drawings

CAD drawings can be downloaded from the website. [www.intelligentactuator.com](http://www.intelligentactuator.com)



[No Brake]

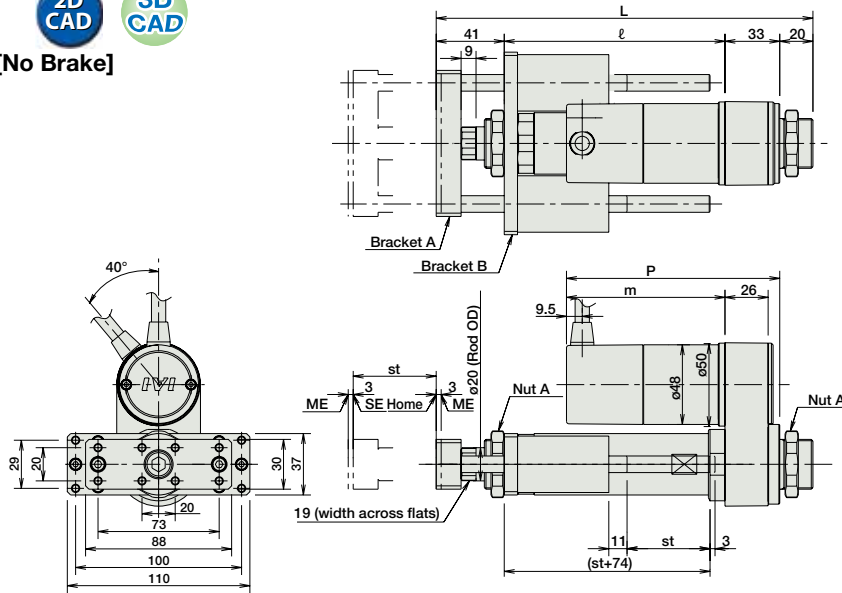

[Brake-Equipped]

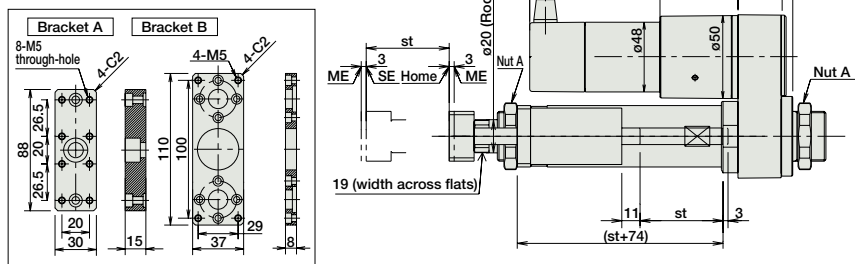

For Special Orders

Appendix P.15

- (\*1) Connect the motor and encoder cables here. See page A-59 for details on cables.
- (\*2) After homing, the slider moves to the ME, therefore, please watch for any interference with surrounding objects.  
ME : Mechanical end SE : Stroke end
- (\*3) The orientation of the bolt varies depending on the product.

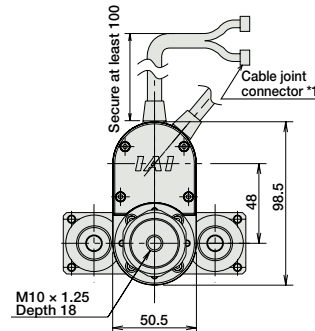

### Dimensions and Weight by Stroke

RCS2-RGD4R (without brake)							
Stroke	50	100	150	200	250	300	
L	20W	227	277	327	377	427	477
	30W	227	277	327	377	427	477
ℓ	133	183	233	283	333	383	
m	20W	80.5					
	30W	95.5					
p	20W	113.5					
	30W	128.5					
Weight (kg)	1.9	2.2	2.3	2.6	2.7	3.0	

RCS2-RGD4R (with brake)							
Stroke	50	100	150	200	250	300	
L	20W	227	277	327	377	427	477
	30W	227	277	327	377	427	477
ℓ	133	183	233	283	333	383	
m	20W	123.w5					
	30W	138.5					
p	20W	156.5					
	30W	171.5					
Weight (kg)	2.1	2.4	2.5	2.8	2.9	3.2	

### Applicable Controllers

RCS2-series actuators can be operated with the following controllers. Select an appropriate controller type according to your application.

Name	External view	Model number	Features	Maximum number of positioning points	Input power	Power supply capacity	Standard price	Reference page
Positioner mode			Up to 512 positioning points are supported.	512 points				
Solenoid valve mode		SCON-CA-20①-NP-2-② SCON-CA-30D①-NP-2-②	Actuators can be operated through the same control used for solenoid valves.	7 points				
Field network type			Movement by numerical specification is supported.	768 points	Single-phase 100VAC	126 VA max. *Power supply capacity will vary depending on the controller, so please refer to the instruction manual for details.		→ P643
Pulse-train input control type			Dedicated pulse-train input type	(—)	Single-phase 200VAC			
Positioner multi-axis, network type		MSCON-C-1-20①-V-0-② MSCON-C-1-30D①-V-0-②	Up to 6 axes can be operated. Movement by numerical specification is supported.	256 points	3-phase 200VAC (XSEL-P/Q/R/S ONLY)			→ P655
Program control type, 1 to 2 axes		SSEL-CS-1-20①-NP-2-② SSEL-CS-1-30D①-NP-2-②	Program operation is supported. Up to 2 axes can be operated.	20,000 points				→ P685
Program control type, 1 to 8 axes		XSEL-③-1-20①-N1-EEE-2-④ XSEL-③-1-30D①-N1-EEE-2-④	Program operation is supported. Up to 8 axes can be operated.	Varies depending on the number of axes connected				→ P695

\* This is for the single-axis MSCON, SSEL, and XSEL.

① indicates the power-supply voltage type (1: 100V / 2: Single-phase 200V).

② indicates the power-supply voltage type (1: 100V / 2: Single-phase 200V / 3: Three-phase 200V).

③ indicates the encoder type (I: Incremental / A: Absolute).

④ indicates the XSEL type (J / K / P / Q / R / S).

\* indicates field network specification symbol.