



## Gripper Type / Rotary Type

### RCP2 RCS2



RCP2-GRSS



RCP2-GRLS



RCP2-GRS



RCP2-GRM



RCP2-GRST



RCP2-GRHM



RCP2-GRHB



RCP2-GR3LS



RCP2-GR3SS



RCS2-GR8



RCP2-RTBS/RTBSL



RCP2-RTB/RTBL



RCP2-RTBB/RTBBL



RCP2-RTCS/RTCSL



RCP2-RTC/RTCL



RCP2-RTCB/RTCBL



RCS2-RTC8L/RTC8HL



RCS2-RTC10L



RCS2-RTC12L



RCS2-RT6

# Gripper Type / Rotary Type

<b>RCP2 series</b> Pulse Motor Type	2-Finger Gripper	Mini Slider Type	42mm Width	RCP2-GRSS	<b>373</b>
		Mini Lever Type	42mm Width	RCP2-GRLS	<b>375</b>
		Small Slider Type	69mm Width	RCP2-GRS	<b>377</b>
		Medium Slider Type	74mm Width	RCP2-GRM	<b>379</b>
		Long Stroke Slider Type	130mm Width ? 190mm Width	RCP2-GRST	<b>381</b>
	3-Finger Gripper	Medium High-force Gripper	116mm Width	RCP2-GRHM	<b>383</b>
		Large High-force Gripper	131mm Width	RCP2-GRHB	<b>385</b>
		Lever Type	62mm Width	RCP2-GR3LS	<b>387</b>
		Slider Type	80mm Width	RCP2-GR3LM	<b>389</b>
62mm Width	RCP2-GR3SS		<b>391</b>		
80mm Width	RCP2-GR3SM	<b>393</b>			
<b>RCS2 series</b> 200V Servo Motor Type	2-Finger Gripper	Long Stroke Slider Type	104mm Width ? 284mm Width	RCS2-GR8	<b>395</b>
<b>RCP2 series</b> Pulse Motor Type	Rotary	Small Vertical Type	45mm Width	RCP2-RTBS/RTBSL	<b>397</b>
		Small Flat Type	72mm Width	RCP2-RTCS/RTCSL	<b>399</b>
		Medium Vertical Type	50mm Width	RCP2-RTB/RTBL	<b>401</b>
		Medium Flat Type	88mm Width	RCP2-RTC/RTCL	<b>403</b>
		Large Vertical Type	76mm Width	RCP2-RTBB/RTBBL	<b>405</b>
		Large Flat Type	124mm Width	RCP2-RTCB/RTCBL	<b>407</b>
<b>RCS2 series</b> 200V Servo Motor Type	Hollow Rotary	Small Type	85mm Width	RCS2-RTC8L/RTC8HL	<b>409</b>
		Medium Type	99mm Width	RCS2-RTC10L	<b>411</b>
		Large Type	123mm Width	RCS2-RTC12L	<b>413</b>
	Rotary	Straight Motor Type	64mm Width	RCS2-RT6	<b>415</b>

Slider Type

Mini

Standard

Controllers Integrated

Rod Type

Mini

Standard

Controllers Integrated

Table/Arm/Flat Type

Mini

Standard

Gripper/Rotary Type

Linear Servo Type

Clean-room Type

Splash-Proof Type

Pulse Motor

Servo Motor (24V)

Servo Motor (200V)

Linear Servo Motor

Gripper Type / Rotary Type **372**

Sold &amp; Serviced By:

**ELECTROMATE**

Toll Free Phone (877) SERV098

Toll Free Fax (877) SERV099

www.electromate.com

sales@electromate.com

# RCP2-GRSS

ROBO Cylinder, 2-Finger Gripper, Mini Slider Type, Actuator Width 42mm, Pulse Motor

Model Specification Items	<b>RCP2</b> — <b>GRSS</b> — <b>I</b> — <b>20P</b> — <b>30</b> — <b>8</b> —	□	□	□
	Series — Type — Encoder type — Motor type — Deceleration Ratio — Stroke —	Applicable controller —	Cable length —	Options
	I: Incremental * The Simple absolute encoder is also considered type "I".	20P: Pulse motor, 20□ size	30 :1/30 deceleration ratio (4mm per side)	8: 8mm (4mm per side)
		P1: PCON-PL/PO/SE PSEL P3: PCON-CA PMEC/PSEP MSEP	N: None P: 1m S: 3m M: 5m X□□: Custom Length	NM: Non-motor end FB: Flange bracket SB: Shaft bracket

\* See page Pre-47 for details on the model descriptions.



Technical References Appendix P.5



- (1) The maximum opening/closing speed indicates the operating speed on one side. The relative operating speed is twice this value.
- (2) The maximum gripping force is the sum of the gripping forces of both fingers, at a gripping point where there is no offset or overhang distance. The work piece weight that can be actually moved depends on the friction coefficient between the gripper fingers and the work piece, as well as on the shape of the work piece. As a rough guide, a work piece's weight should not exceed 1/10 to 1/20 of the gripping force. (See page A-86 for details.)
- (3) The rated acceleration while moving is 0.3G.

### Gripping Force vs. Current Limit

The gripping (pushing) force can be adjusted freely within the range of current limits of 20% to 70%.

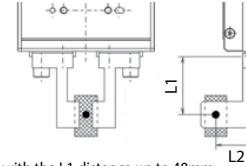

- \* Operate with the L1 distance up to 40mm.
  - \* The gripping force value in the graph below is when both L1 and L2 are at 0 mm. (For gripping force reference per L1 distance, see page A-87.)
- The gripping force value is the sum of gripping forces of both fingers.

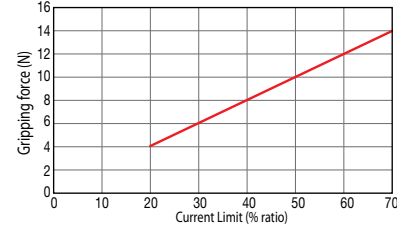

\* The gripping force graph above shows reference numbers. Please allow margins up to ± 15%.

\* Please note that, when gripping (pushing), the speed is fixed at 5mm/s.

### Actuator Specifications

#### Lead and Payload

Model number	Deceleration Ratio	Maximum Gripping Force (N)	Stroke (mm)
RCP2-GRSS-I-20P-30-8-①-②-③	30	14 (7 per side)	8 (4 per side)

Code explanation ① Applicable Controller ② Cable length ③ Options

#### Stroke and Max. Opening/Closing Speed

Stroke / Deceleration ratio	8 (mm) / (per side)
30	78 (per side)

(Unit: mm/s)

#### Stroke

Stroke (mm)	Standard price
8	—

#### ② Cable Length

Type	Cable symbol	Standard price
Standard (Robot Cables)	P (1m)	—
	S (3m)	—
	M (5m)	—
Special length	X06 (6m) ~ X10 (10m)	—
	X11 (11m) ~ X15 (15m)	—
	X16 (16m) ~ X20 (20m)	—

\* The standard cable is the motor-encoder integrated robot cable.  
\* See page A-59 for cables for maintenance.

#### ③ Options

Name	Option code	See page	Standard price
Non-motor end specification	NM	→ A-52	—
Flange bracket	FB	→ A-43	—
Shaft bracket	SB	→ A-55	—

#### Actuator Specifications

Item	Description
Drive System	Worm gear + helical gear + helical rack
Positioning repeatability	±0.01mm
Backlash	0.2mm or less per side (constantly pressed out by a spring)
Lost motion	0.05mm or less per side
Guide	Linear guide
Allowable static load moment	Ma: 0.5 N·m, Mb: 0.5 N·m, Mc: 1.5 N·m
Weight	0.2kg
Ambient operating temperature, humidity	0 to 40°C, 85% RH or less (Non-condensing)

373 RCP2-GRSS

Dimensional Drawings

For Special Orders  Appendix P.15



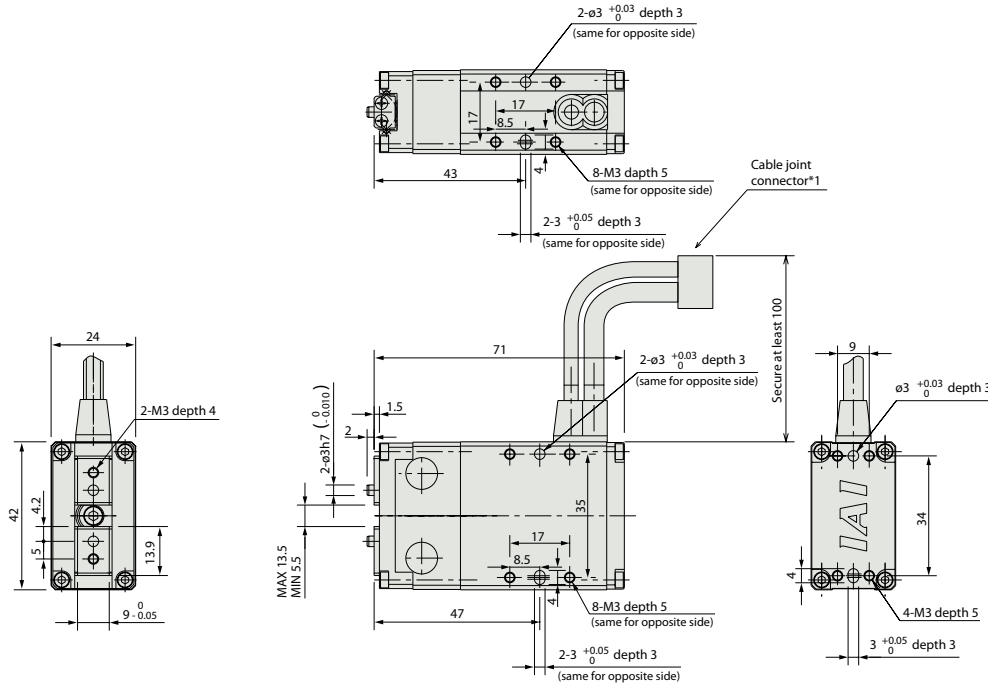



\*The opening side of the slider is the home position.  
 (\*1) Connect the motor-encoder integrated cable here. See page A-59 for details on cables.



Weight (kg) 0.2

① Applicable Controllers

RCP2 series actuators can be operated with the controllers indicated below. Select the type according to your intended application.

Name	External view	Model number	Features	Maximum number of positioning points	Input power	Power-supply capacity	Standard price	Reference page
Solenoid Valve Type		PMEC-C-20PI-①-2-②	Easy-to-use controller, even for beginners	3 points	AC100V AC200V	Refer to P541	—	→ P537
		PSEP-C-20PI-①-2-0	Simple controller operable with the same signal as a solenoid valve			Refer to P555	—	→ P547
Solenoid valve multi-axis type PIO specification		MSEP-C-③④⑤⑥⑦⑧⑨⑩-①-2-0	Positioner type based on PIO control, allowing up to 8 axes to be connected	256 points	DC24V	Refer to P572	—	→ P563
Solenoid valve multi-axis type Network specification		MSEP-C-③④⑤⑥⑦⑧⑨⑩-④-0-0	Field network-ready positioner type, allowing up to 8 axes to be connected			Refer to P618	—	→ P607
Positioner type High-output specification		PCON-CA-20PI-①-2-0	Equipped with a high-output driver Positioner type based on PIO control	512 points	DC24V	Refer to P618	—	→ P607
Pulse-train type High-output specification		PCON-CA-20PI-PL□-2-0	Equipped with a high-output driver Pulse-train input type	(—)		Refer to P628	—	
Field network type High-output specification		PCON-CA-20PI-④-0-0	Equipped with a high-output driver Supporting 7 major field networks	768 points		Refer to P628	—	
Pulse Train Input Type (Differential Line Driver)		PCON-PL-20PI-①-2-0	Pulse train input type with differential line driver support	(—)	DC24V	Refer to P628	—	→ P623
Pulse Train Input Type (Open Collector)		PCON-PO-20PI-①-2-0	Pulse train input type with open collector support			Refer to P671	—	
Serial Communication Type		PCON-SE-20PI-N-0-0	Dedicated Serial Communication	64 points	DC24V	Refer to P671	—	→ P665
Program Control Type		PSEL-CS-1-20PI-①-2-0	Programmed operation is possible. Can operate up to 2 axes	1,500 points		Refer to P671	—	

\* This is for the single-axis PSEL. \* ① indicates I/O type (NP/PN). \* ② indicates power supply voltage (1: 100V / 2: 100~240V).  
 \* ③④⑤⑥⑦⑧⑨⑩ indicates number of axes (1 to 8). \* ④ indicates field network specification symbol. \* □ indicates N (NPN specification) or P (PNP specification) symbol.



RCP2-GRSS **374**

- Slider Type
- Mini
- Standard
- Controllers Integrated
- Rod Type
- Mini
- Standard
- Controllers Integrated
- Table/ Arm/ Flat Type
- Mini
- Standard
- Gripper/ Rotary Type
- Linear Servo Type
- Clean-room Type
- Splash-Proof Type
- Pulse Motor
- Servo Motor (24V)
- Servo Motor (200V)
- Linear Servo Motor



# RCP2-GRLS

ROBO Cylinder, 2-Finger Gripper, Mini Lever Type, Actuator Width 42mm, Pulse Motor

Model Specification Items	<b>RCP2</b> — <b>GRLS</b> — <b>I</b> — <b>20P</b> — <b>30</b> — <b>180</b> —	<input type="checkbox"/>	<input type="checkbox"/>	<input type="checkbox"/>
	Series — Type — Encoder type — Motor type — Deceleration Ratio — Stroke — Applicable controller — Cable length — Options			
	I: Incremental * The Simple absolute encoder is also considered type "I".	20P: Pulse motor, 20□ size	30: 1/30 deceleration ratio	180: 180 degrees (90 degrees per side)
			P1: PCON-PL/PO/SE PSEL P3: PCON-CA PMEC/PSEP MSEP	N: None P: 1m S: 3m M: 5m X□□: Custom Length
				NM: Non-motor end FB: Flange bracket SB: Shaft bracket

\* See page Pre-47 for details on the model descriptions.



Technical References Appendix P.5

- POINT**  
Notes on selection
- The maximum opening/closing speed indicates the operating speed on one side. The relative operating speed is twice this value.
  - The maximum gripping force is the sum of the gripping forces of both fingers, at a gripping point where there is no offset or overhang distance. The work piece weight that can be actually moved depends on the friction coefficient between the gripper fingers and the work piece, as well as on the shape of the work piece. As a rough guide, a work piece's weight should not exceed 1/10 to 1/20 of the gripping force. (See page A-86 for details.)
  - The rated acceleration while moving is 0.3G.

### Gripping Force vs. Current Limit

The gripping (pushing) force can be adjusted freely within the range of current limits of 20% to 70%.

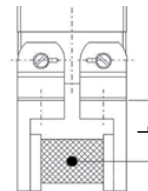

\* The gripping force of the graph below is measured on the top face of the lever. The actual gripping force drops in inverse proportion to the distance from the opening/closing fulcrum. Calculate the effective gripping force using the formula below.

\* Operate with the L distance up to 40mm.

$$\text{Effective gripping force (GRLS)} = F \times 15.5 / (L + 15.5)$$

\* In the graph below, the gripping force value is the sum of gripping forces of both fingers.

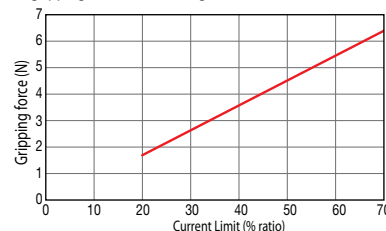

\* The gripping force graph above shows reference numbers. Please allow margins up to ± 15%.

\* Please note that, when gripping (pushing), the speed is fixed at 5 degrees/s.

### Actuator Specifications

#### Lead and Payload

Model number	Deceleration Ratio	Maximum Gripping Force (N)	Stroke (deg)
RCP2-GRLS-I-20P-30-180-①-②-③	30	6.4 (3.2 per side)	180 (90 per side)

Code explanation ① Applicable Controller ② Cable length ③ Options

#### Stroke and Max. Opening/Closing Speed

Deceleration ratio	Stroke	180 (deg)
	30	600 (per side)

(Unit: degree/s)

#### Stroke

Stroke (deg)	Standard price
180	—

#### ② Cable Length

Type	Cable symbol	Standard price
Standard (Robot Cables)	P (1m)	—
	S (3m)	—
	M (5m)	—
Special length	X06 (6m) ~ X10 (10m)	—
	X11 (11m) ~ X15 (15m)	—
	X16 (16m) ~ X20 (20m)	—

\* The standard cable is the motor-encoder integrated robot cable.  
\* See page A-59 for cables for maintenance.

#### ③ Options

Name	Option code	See page	Standard price
Non-motor end specification	NM	→ A-52	—
Flange bracket	FB	→ A-43	—
Shaft bracket	SB	→ A-55	—

#### Actuator Specifications

Item	Description
Drive System	Worm gear + helical gear
Positioning repeatability	±0.01deg.
Backlash	1 degree or less per side (constantly pressed out by a spring)
Lost motion	1 degree or less
Guide	—
Allowable static load moment	—
Weight	0.2kg
Ambient operating temperature, humidity	0 to 40°C, 85% RH or less (Non-condensing)

# 375

RCP2-GRLS

Dimensional Drawings

For Special Orders Appendix P.15

\*The opening side of the slider is the home position.  
 (\*1) Connect the motor-encoder integrated cable here. See page A-59 for details on cables.

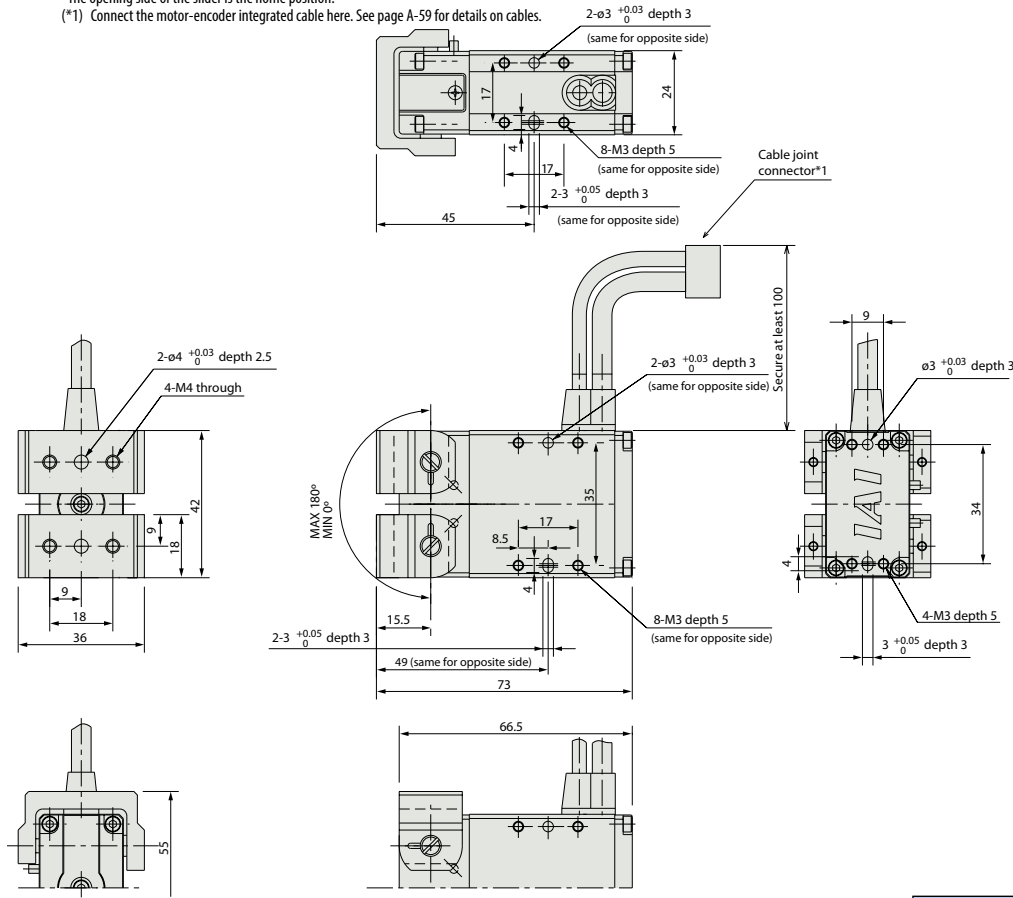

Weight (kg) 0.2

① Applicable Controllers

RCP2 series actuators can be operated with the controllers indicated below. Select the type according to your intended application.

Name	External view	Model number	Features	Maximum number of positioning points	Input power	Power-supply capacity	Standard price	Reference page
Solenoid Valve Type		PMEC-C-20PI-(1)-2-(1)	Easy-to-use controller, even for beginners	3 points	AC100V AC200V	Refer to P541	—	→ P537
		PSEP-C-20PI-(1)-2-0	Simple controller operable with the same signal as a solenoid valve					→ P547
Solenoid valve multi-axis type PIO specification		MSEP-C-(1)-(1)-2-0	Positioner type based on PIO control, allowing up to 8 axes to be connected	256 points	DC24V	Refer to P572	—	→ P563
Solenoid valve multi-axis type Network specification		MSEP-C-(1)-(1)-0-0	Field network-ready positioner type, allowing up to 8 axes to be connected					→ P607
Positioner type High-output specification		PCON-CA-20PI-(1)-2-0	Equipped with a high-output driver Positioner type based on PIO control	512 points	DC24V	Refer to P618	—	→ P623
Pulse-train type High-output specification		PCON-CA-20PI-PL□-2-0	Equipped with a high-output driver Pulse-train input type	(—)				
Field network type High-output specification		PCON-CA-20PI-(1)-0-0	Equipped with a high-output driver Supporting 7 major field networks	768 points				
Pulse Train Input Type (Differential Line Driver)		PCON-PL-20PI-(1)-2-0	Pulse train input type with differential line driver support	(—)	DC24V	Refer to P628	—	→ P623
Pulse Train Input Type (Open Collector)		PCON-PO-20PI-(1)-2-0	Pulse train input type with open collector support					
Serial Communication Type		PCON-SE-20PI-N-0-0	Dedicated Serial Communication	64 points	DC24V	Refer to P671	—	→ P665
Program Control Type		PSEL-CS-1-20PI-(1)-2-0	Programmed operation is possible. Can operate up to 2 axes	1,500 points	DC24V	Refer to P671	—	→ P665

\* This is for the single-axis PSEL. \* (1) indicates I/O type (NP/PN). \* (1) indicates power supply voltage (1: 100V / 2: 100~240V).  
 \* (1) indicates number of axes (1 to 8). \* (1) indicates field network specification symbol. \* □ indicates N (NPN specification) or P (PNP specification) symbol.



RCP2-GRLS 376

- Slider Type
- Mini
- Standard
- Controllers Integrated
- Rod Type
- Mini
- Standard
- Controllers Integrated
- Table/ Arm/ Flat Type
- Mini
- Standard
- Gripper/ Rotary Type
- Linear Servo Type
- Clean-room Type
- Splash-Proof Type
- Pulse Motor
- Servo Motor (24V)
- Servo Motor (200V)
- Linear Servo Motor

- Slider Type
- Mini
- Standard
- Controllers Integrated
- Rod Type
- Mini
- Standard
- Controllers Integrated
- Table/ Arm/ Flat Type
- Mini
- Standard
- Gripper/ Rotary Type
- Linear Servo Type
- Clean-room Type
- Splash-Proof Type
- Pulse Motor
- Servo Motor (24V)
- Servo Motor (200V)
- Linear Servo Motor

# RCP2-GRS

ROBO Cylinder, 2-Finger Gripper, Mini Slider Type, Actuator Width 69mm, Pulse Motor

Model Specification Items	<b>RCP2</b> — <b>GRS</b>	— Encoder type —	<b>I</b> — <b>20P</b>	— Motor type —	<b>1</b> — <b>10</b>	— Deceleration Ratio —	— Stroke —	— Applicable controller —	— Cable length —	— Options —
			I: Incremental * The Simple absolute encoder is also considered type "I".	20P: Pulse motor, 20□ size	1: 1/1 deceleration ratio	10: 10mm (5mm per side)	P1: PCON-PL/PO/SE PSEL P3: PCON-CA PMEC/PSEP MSEP	N: None P: 1m S: 3m M: 5m X□□: Custom Length R□□: Robot cable	SB: Shaft bracket FB: Flange bracket	

\* See page Pre-47 for details on the model descriptions.



Technical References Appendix P.5

- POINT** Notes on selection
- The maximum opening/closing speed indicates the operating speed on one side. The relative operating speed is twice this value.
  - The maximum gripping force is the sum of the gripping forces of both fingers, at a gripping point where there is no offset or overhang distance. The work piece weight that can be actually moved depends on the friction coefficient between the gripper fingers and the work piece, as well as on the shape of the work piece. As a rough guide, a work piece's weight should not exceed 1/10 to 1/20 of the gripping force. (See page A-86 for details.)
  - The rated acceleration while moving is 0.3G.

### Gripping Force vs. Current Limit

The gripping (pushing) force can be adjusted freely within the range of current limits of 20% to 70%.

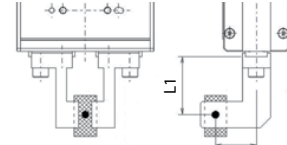

- \* Operate with the L1 distance up to 50mm. L2
- \* The gripping force value in the graph below is when both L1 and L2 are at 0 mm. (For gripping force reference per L1 distance, see page A-87.)
- The gripping force value is the sum of gripping forces of both fingers.

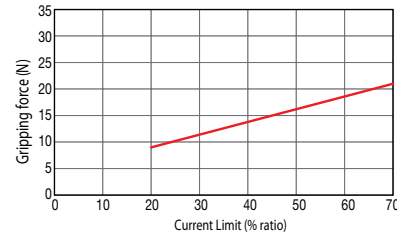

- \* The gripping force graph above shows reference numbers. Please allow margins up to ± 15%.
- \* Please note that, when gripping (pushing), the speed is fixed at 5mm/s.

### Actuator Specifications

#### Lead and Payload

Model number	Deceleration Ratio	Maximum Gripping Force (N)	Stroke (mm)
RCP2-GRS-I-20P-1-10-①-②-③	1	21 (10.5 per side)	10 (5 per side)

Code explanation ① Applicable Controller ② Cable length ③ Options

#### Stroke and Max. Opening/Closing Speed

Deceleration ratio	Stroke	10 (mm)
	1	33.3 (per side)

(Unit: mm/s)

#### Stroke

Stroke (mm)	Standard price
10	—

#### ② Cable Length

Type	Cable symbol	Standard Price
Standard	P (1m)	—
	S (3m)	—
	M (5m)	—
Special length	X06 (6m) ~ X10 (10m)	—
	X11 (11m) ~ X15 (15m)	—
	X16 (16m) ~ X20 (20m)	—
	R01 (1m) ~ R03 (3m)	—
Robot Cable	R04 (4m) ~ R05 (5m)	—
	R06 (6m) ~ R10 (10m)	—
	R11 (11m) ~ R15 (15m)	—
	R16 (16m) ~ R20 (20m)	—

\* See page A-59 for cables for maintenance.

#### ③ Options

Name	Option code	See page	Standard price
Flange bracket	FB	→ A-43	—
Shaft bracket	SB	→ A-55	—

#### Actuator Specifications

Item	Description
Drive System	Timing belt + trapezoidal screw (1.5 lead)
Positioning repeatability	±0.01mm
Backlash	0.15mm or less per side (constantly pressed out by a spring)
Lost motion	0.1mm or less per side
Guide	Cross roller guide
Allowable static load moment	Ma: 6.3 N·m, Mb: 6.3 N·m, Mc: 7.0 N·m
Weight	0.36kg
Ambient operating temperature, humidity	0 to 40°C, 85% RH or less (Non-condensing)

**377** RCP2-GRS



# RCP2-GRM

ROBO Cylinder, 2-Finger Gripper, Medium Slider Type, Actuator Width 74mm, Pulse Motor

Model Specification Items	<b>RCP2</b> — <b>GRM</b> — <b>I</b> — <b>28P</b> — <b>1</b> — <b>14</b> —	Applicable controller	Cable length	Options				
Series	Type	Encoder type	Motor type	Deceleration Ratio	Stroke	P1: PCON-PL/PO/SE PSEL P3: PCON-CA PMEC/PSEP MSEP	N: None P: 1m S: 3m M: 5m X□: Custom Length R□: Robot cable	SB: Shaft bracket FB: Flange bracket
I: Incremental		28P: Pulse motor, 1: 1/1	14: 14mm	* The Simple absolute encoder is also considered type "I".				

\* See page Pre-47 for details on the model descriptions.



Technical References Appendix P.5



- (1) The maximum opening/closing speed indicates the operating speed on one side. The relative operating speed is twice this value.
- (2) The maximum gripping force is the sum of the gripping forces of both fingers, at a gripping point where there is no offset or overhang distance. The work piece weight that can be actually moved depends on the friction coefficient between the gripper fingers and the work piece, as well as on the shape of the work piece. As a rough guide, a work piece's weight should not exceed 1/10 to 1/20 of the gripping force. (See page A-86 for details.)
- (3) The rated acceleration while moving is 0.3G.

### Gripping Force vs. Current Limit

The gripping (pushing) force can be adjusted freely within the range of current limits of 20% to 70%.

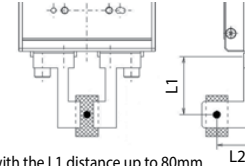

- \* Operate with the L1 distance up to 80mm.
  - \* The gripping force value in the graph below is when both L1 and L2 are at 0 mm. (For gripping force reference per L1 distance, see page A-87.)
- The gripping force value is the sum of gripping forces of both fingers.

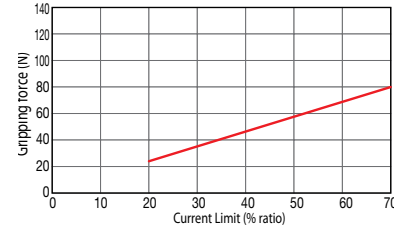

- \* The gripping force graph above shows reference numbers. Please allow margins up to ± 15%.
- \* Please note that, when gripping (pushing), the speed is fixed at 5mm/s.

### Actuator Specifications

#### Lead and Payload

Model number	Deceleration Ratio	Maximum Gripping Force (N)	Stroke (mm)
RCP2-GRM-I-28P-1-14-①-②-③	1	80 (40 per side)	14 (7 per side)

Code explanation ① Applicable Controller ② Cable length ③ Options

#### Stroke and Max. Opening/Closing Speed

Deceleration ratio	Stroke	14 (mm)
	1	36.7 (per side)

(Unit: mm/s)

#### Stroke

Stroke (mm)	Standard price
14	—

#### ② Cable Length

Type	Cable symbol	Standard Price
Standard	P (1m)	—
	S (3m)	—
	M (5m)	—
Special length	X06 (6m) ~ X10 (10m)	—
	X11 (11m) ~ X15 (15m)	—
	X16 (16m) ~ X20 (20m)	—
	R01 (1m) ~ R03 (3m)	—
Robot Cable	R04 (4m) ~ R05 (5m)	—
	R06 (6m) ~ R10 (10m)	—
	R11 (11m) ~ R15 (15m)	—
	R16 (16m) ~ R20 (20m)	—

\* See page A-59 for cables for maintenance.

#### ③ Options

Name	Option code	See page	Standard price
Flange bracket	FB	→ A-43	—
Shaft bracket	SB	→ A-55	—

#### Actuator Specifications

Item	Description
Drive System	Timing belt + trapezoidal screw (1.5 lead)
Positioning repeatability	±0.01mm
Backlash	0.15mm or less per side (constantly pressed out by a spring)
Lost motion	0.1mm or less per side
Guide	Cross roller guide
Allowable static load moment	Ma: 6.3 N·m, Mb: 6.3 N·m, Mc: 8.3 N·m
Weight	0.5kg
Ambient operating temperature, humidity	0 to 40°C, 85% RH or less (Non-condensing)

379 RCP2-GRM







Dimensional Drawings

For Special Orders Appendix P.15

\*The opening side of the slider is the home position.  
 (\*1) Connect the motor-encoder integrated cable here. See page A-59 for details on cables.

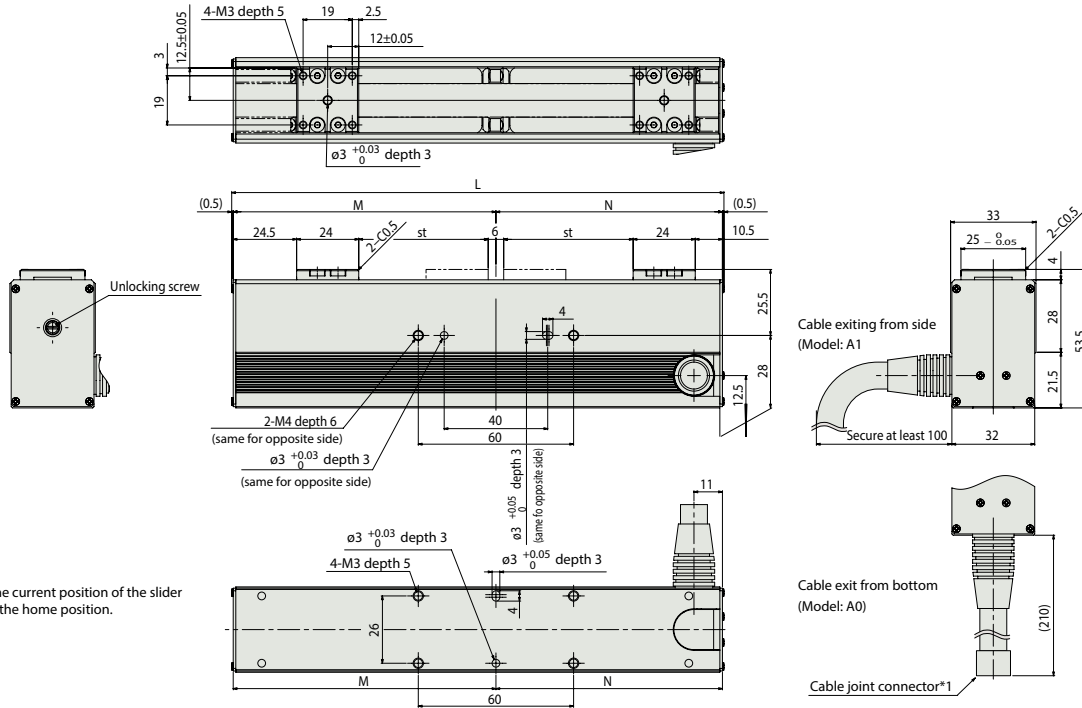

■ Dimensions and Weight by Stroke

Stroke	40	60	80	100
L	130	150	170	190
M	71.5	81.5	91.5	101.5
N	57.5	67.5	77.5	87.5
Weight (kg)	0.51	0.56	0.61	0.66

② Applicable Controllers

RCP2 series actuators can be operated with the controllers indicated below. Select the type according to your intended application.

Name	External view	Model number	Features	Maximum number of positioning points	Input power	Power-supply capacity	Standard price	Reference page
Solenoid Valve Type		PMEC-C-20PI-①-2-②	Easy-to-use controller, even for beginners	3 points	AC100V AC200V	Refer to P541	—	→ P537
		PSEP-C-20PI-①-2-0	Simple controller operable with the same signal as a solenoid valve					
Solenoid valve multi-axis type PIO specification		MSEP-C-③-④-⑤-⑥-⑦-2-0	Positioner type based on PIO control, allowing up to 8 axes to be connected	256 points	DC24V	Refer to P572	—	→ P563
Solenoid valve multi-axis type Network specification		MSEP-C-③-④-⑤-⑥-⑦-0-0	Field network-ready positioner type, allowing up to 8 axes to be connected					
Positioner type High-output specification		PCON-CA-20PI-①-2-0	Equipped with a high-output driver Positioner type based on PIO control	512 points	DC24V	Refer to P618	—	→ P607
Pulse-train type High-output specification		PCON-CA-20PI-PL□-2-0	Equipped with a high-output driver Pulse-train input type	(—)				
Field network type High-output specification		PCON-CA-20PI-④-0-0	Equipped with a high-output driver Supporting 7 major field networks	768 points				
Pulse Train Input Type (Differential Line Driver)		PCON-PL-20PI-①-2-0	Pulse train input type with differential line driver support	(—)	DC24V	Refer to P628	—	→ P623
Pulse Train Input Type (Open Collector)		PCON-PO-20PI-①-2-0	Pulse train input type with open collector support					
Serial Communication Type		PCON-SE-20PI-N-0-0	Dedicated Serial Communication	64 points	DC24V	Refer to P671	—	→ P665
Program Control Type		PSEL-CS-1-20PI-①-2-0	Programmed operation is possible. Can operate up to 2 axes	1,500 points	DC24V	Refer to P671	—	→ P665

\* This is for the single-axis PSEL. \* ① indicates I/O type (NP/PN). \* ② indicates power supply voltage (1: 100V / 2: 100~240V).  
 \* ③ indicates number of axes (1 to 8). \* ④ indicates field network specification symbol. \* □ indicates N (NPN specification) or P (PNP specification) symbol.

- Slider Type
- Mini
- Standard
- Controllers Integrated
- Rod Type
- Mini
- Standard
- Controllers Integrated
- Table/ Arm/ Flat Type
- Mini
- Standard
- Gripper/ Rotary Type
- Linear Servo Type
- Clean-room Type
- Splash-Proof Type
- Pulse Motor
- Servo Motor (24V)
- Servo Motor (200V)
- Linear Servo Motor



# RCP2-GRHM

ROBO Cylinder, 2-Finger Gripper, Medium High-force Type, Actuator Width 116mm, 24V Pulse Motor

Model Specification Items	<b>RCP2</b>	<b>GRHM</b>	<b>I</b>	<b>35P</b>	<b>2</b>	<b>32</b>	<input type="checkbox"/>	<input type="checkbox"/>	<input type="checkbox"/>
	Series	Type	Encoder type	Motor type	Deceleration Ratio	Stroke	Applicable controller	Cable length	Options
			I: Incremental	35P: Pulse motor, 35□ size	2: Feed screw lead 2	32: 32mm (16mm per side)	P1: PCON-PL/PO/SE PSEL P3: PCON-CA PMEC/PSEP MSEP	N: None P: 1m S: 3m M: 5m X□□: Custom Length	See Options below.

\* See page Pre-47 for details on the model descriptions.



Technical References Appendix P.5



- (1) The maximum opening/closing speed indicates the operating speed on one side. The relative operating speed is twice this value.
- (2) The maximum gripping force is the sum of the gripping forces of both fingers, at a gripping point where there is no offset or overhang distance. The work piece weight that can be actually moved depends on the friction coefficient between the gripper fingers and the work piece, as well as on the shape of the work piece. As a rough guide, a work piece's weight should not exceed 1/10 to 1/20 of the gripping force. (See page A-86 for details.)
- (3) The rated acceleration while moving is 0.3G.

### Gripping Force vs. Current Limit

The gripping (pushing) force can be adjusted freely within the range of current limits of 20% to 70%.

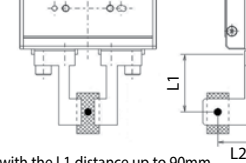

\* Operate with the L1 distance up to 90mm.

\* The gripping force value in the graph below is when both L1 and L2 are at 0 mm. (For gripping force reference per L1 distance, see page A-87.)

The gripping force value is the sum of gripping forces of both fingers.

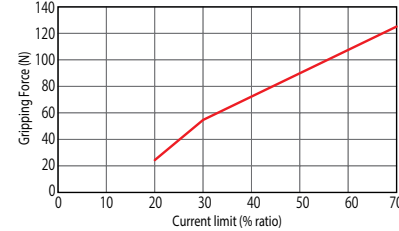

\* The gripping force graph above shows reference numbers. Please allow margins up to ± 15%.

\* Please note that, when gripping (pushing), the speed is fixed at 5mm/s.

### Actuator Specifications

#### Lead and Payload

Model number	Deceleration Ratio	Maximum Gripping Force (N)	Stroke (mm)
RCP2-GRHM-I-35P-2-32-①-②-③	2	125 (62.5 per side)	32 (16 per side)

Code explanation ① Applicable Controller ② Cable length ③ Options

#### Stroke and Max. Opening/Closing Speed

Deceleration ratio	Stroke	32 (mm)
	2	100 (per side)

(Unit: mm/s)

#### Stroke

Stroke (mm)	Standard price
32	—

#### ② Cable Length

Type	Cable symbol	Standard price
Standard (Robot Cables)	P (1m)	—
	S (3m)	—
	M (5m)	—
Special length	X06 (6m) ~ X10 (10m)	—
	X11 (11m) ~ X15 (15m)	—
	X16 (16m) ~ X20 (20m)	—

\* The standard cable is the motor-encoder integrated robot cable.  
\* See page A-59 for cables for maintenance.

#### ③ Options

Name	Option code	See page	Standard price
Cable exit direction (top)	CJT	→ A-42	—
Cable exit direction (right)	CJR	→ A-42	—
Cable exit direction (left)	CJL	→ A-42	—
Cable exit direction (bottom)	CJB	→ A-42	—
Flange Bracket	FB	→ A-43	—
Shaft bracket	SB	→ A-55	—

#### Actuator Specifications

Item	Description
Drive System	Timing belt + trapezoidal screw (2 lead)
Positioning repeatability	±0.01mm
Backlash	0.2mm or less per side (constantly pressed out by a spring)
Lost motion	0.15mm or less per side
Guide	Linear guide
Allowable static load moment (*)	Ma: 11.7 N-m, Mb: 16.7 N-m, Mc: 46.5 N-m
Weight	1.14kg
Ambient operating temperature, humidity	0 to 40°C, 85% RH or less (Non-condensing)

(\*) Based on a 5,000km service life.

# 383

RCP2-GRHM

Dimensional Drawings

For Special Orders  Appendix P.15

\* Connect the motor-encoder integrated cable here.  
(See page A-59 for details on cables.)

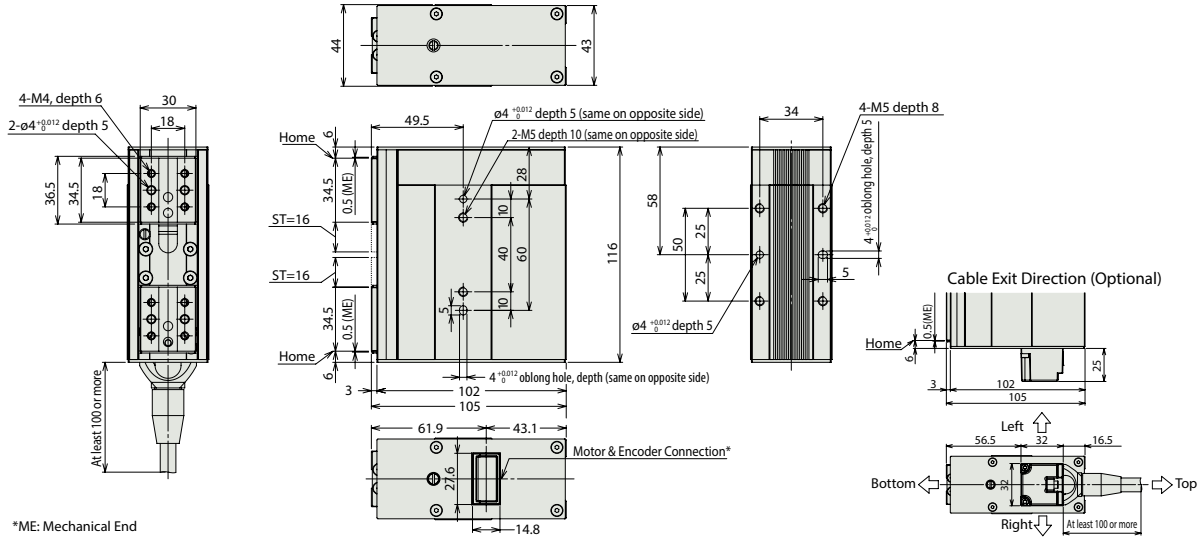







\*ME: Mechanical End

Weight (kg) 1.14

① Applicable Controllers

RCP2 series actuators can be operated with the controllers indicated below. Select the type according to your intended application.

Name	External view	Model number	Features	Maximum number of positioning points	Input power	Power-supply capacity	Standard price	Reference page
Solenoid Valve Type		PMEC-C-35PI-①-2-②	Easy-to-use controller, even for beginners	3 points	AC100V AC200V	Refer to P541	—	→ P537
		PSEP-C-35PI-①-2-0	Simple controller operable with the same signal as a solenoid valve			Refer to P555	—	→ P547
Solenoid valve multi-axis type PIO specification		MSEP-C-④-③-①-2-0	Positioner type based on PIO control, allowing up to 8 axes to be connected	256 points	DC24V	Refer to P572	—	→ P563
Solenoid valve multi-axis type Network specification		MSEP-C-④-③-④-0-0	Field network-ready positioner type, allowing up to 8 axes to be connected					
Positioner type High-output specification		PCON-CA-35PI-①-2-0	Equipped with a high-output driver Positioner type based on PIO control	512 points	DC24V	Refer to P618	—	→ P607
Pulse-train type High-output specification		PCON-CA-35PI-PL□-2-0	Equipped with a high-output driver Pulse-train input type	(—)				
Field network type High-output specification		PCON-CA-35PI-④-0-0	Equipped with a high-output driver Supporting 7 major field networks	768 points				
Pulse Train Input Type (Differential Line Driver)		PCON-PL-35PI-①-2-0	Pulse train input type with differential line driver support	(—)	DC24V	Refer to P628	—	→ P623
Pulse Train Input Type (Open Collector)		PCON-PO-35PI-①-2-0	Pulse train input type with open collector support					
Serial Communication Type		PCON-SE-35PI-N-0-0	Dedicated Serial Communication	64 points	DC24V	Refer to P671	—	→ P665
Program Control Type		PSEL-CS-1-35PI-①-2-0	Programmed operation is possible. Can operate up to 2 axes	1,500 points	DC24V	Refer to P671	—	→ P665

\* This is for the single-axis PSEL.

\* ① indicates I/O type (NP/PN).

\* ② indicates power supply voltage (1: 100V / 2: 100~240V).

\* ④ indicates number of axes (1 to 8). \* ④ indicates field network specification symbol. \* □ indicates N (NPN specification) or P (PNP specification) symbol.

Slider Type

Mini

Standard

Controllers Integrated

Rod Type

Mini

Standard

Controllers Integrated

Table/Arm/Flat Type

Mini

Standard

Gripper/Rotary Type

Linear Servo Type

Clean-room Type

Splash-Proof Type

Pulse Motor

Servo Motor (24V)

Servo Motor (200V)

Linear Servo Motor

# RCP2-GRHB

ROBO Cylinder, 2-Finger Gripper, Large High-force Type, Actuator Width 131mm, 24V Pulse Motor

Model Specification Items	<b>RCP2</b>	<b>GRHB</b>	<b>I</b>	<b>42P</b>	<b>2</b>	<b>40</b>	<input type="checkbox"/>	<input type="checkbox"/>	<input type="checkbox"/>
	Series	Type	Encoder type	Motor type	Deceleration Ratio	Stroke	Applicable controller	Cable length	Options
			I: Incremental	42P: Pulse motor, 42□ size	2: Feed screw lead 2	40:40mm (20mm per side)	P1: PCON-PL/PO/SE PSEL P3: PCON-CA PMEC/PSEP MSEP	N: None P: 1m S: 3m M: 5m X□□: Custom Length	See Options below.

\* See page Pre-47 for details on the model descriptions.



Technical References Appendix P.5

- POINT** Notes on selection
- The maximum opening/closing speed indicates the operating speed on one side. The relative operating speed is twice this value.
  - The maximum gripping force is the sum of the gripping forces of both fingers, at a gripping point where there is no offset or overhang distance. The work piece weight that can be actually moved depends on the friction coefficient between the gripper fingers and the work piece, as well as on the shape of the work piece. As a rough guide, a work piece's weight should not exceed 1/10 to 1/20 of the gripping force. (See page A-86 for details.)
  - The rated acceleration while moving is 0.3G.

### Gripping Force vs. Current Limit

The gripping (pushing) force can be adjusted freely within the range of current limits of 20% to 70%.

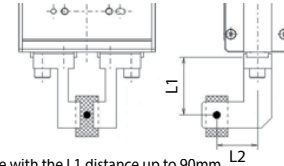

\* Operate with the L1 distance up to 90mm.  
\* The gripping force value in the graph below is when both L1 and L2 are at 0 mm. (For gripping force reference per L1 distance, see page A-87.)  
The gripping force value is the sum of gripping forces of both fingers.

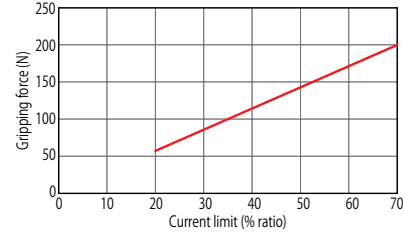

\* The gripping force graph above shows reference numbers. Please allow margins up to ± 15%.

\* Please note that, when gripping (pushing), the speed is fixed at 5mm/s.

### Actuator Specifications

#### Lead and Payload

Model number	Deceleration Ratio	Maximum Gripping Force (N)	Stroke (mm)
RCP2-GRHB-I-42P-2-40-①-②-③	2	200 (100 per side)	40 (20 per side)

Code explanation ① Applicable Controller ② Cable length ③ Options

#### Stroke and Max. Opening/Closing Speed

Deceleration ratio	Stroke	40 (mm)
	2	100 (per side)

(Unit: mm/s)

#### Stroke

Stroke (mm)	Standard price
40	—

#### ② Cable Length

Type	Cable symbol	Standard price
Standard (Robot Cables)	P (1m)	—
	S (3m)	—
	M (5m)	—
Special length	X06 (6m) ~ X10 (10m)	—
	X11 (11m) ~ X15 (15m)	—
	X16 (16m) ~ X20 (20m)	—

\* The standard cable is the motor-encoder integrated robot cable.  
\* See page A-59 for cables for maintenance.

#### ③ Options

Name	Option code	See page	Standard price
Cable exit direction (top)	CJT	→ A-42	—
Cable exit direction (right)	CJR	→ A-42	—
Cable exit direction (left)	CJL	→ A-42	—
Cable exit direction (bottom)	CJB	→ A-42	—
Flange Bracket	FB	→ A-43	—
Shaft bracket	SB	→ A-55	—

#### Actuator Specifications

Item	Description
Drive System	Timing belt + trapezoidal screw (2 lead)
Positioning repeatability	±0.01mm
Backlash	0.2mm or less per side (constantly pressed out by a spring)
Lost motion	0.15mm or less per side
Guide	Linear guide
Allowable static load moment (*)	Ma: 15.7 N·m, Mb: 26.4 N·m, Mc: 59.8 N·m
Weight	1.5kg
Ambient operating temperature, humidity	0 to 40°C, 85% RH or less (Non-condensing)

(\*) Based on a 5,000km service life.

# 385

RCP2-GRHB

Dimensional Drawings

For Special Orders  Appendix P.15

\* Connect the motor-encoder integrated cable here.  
(See page A-59 for details on cables.)

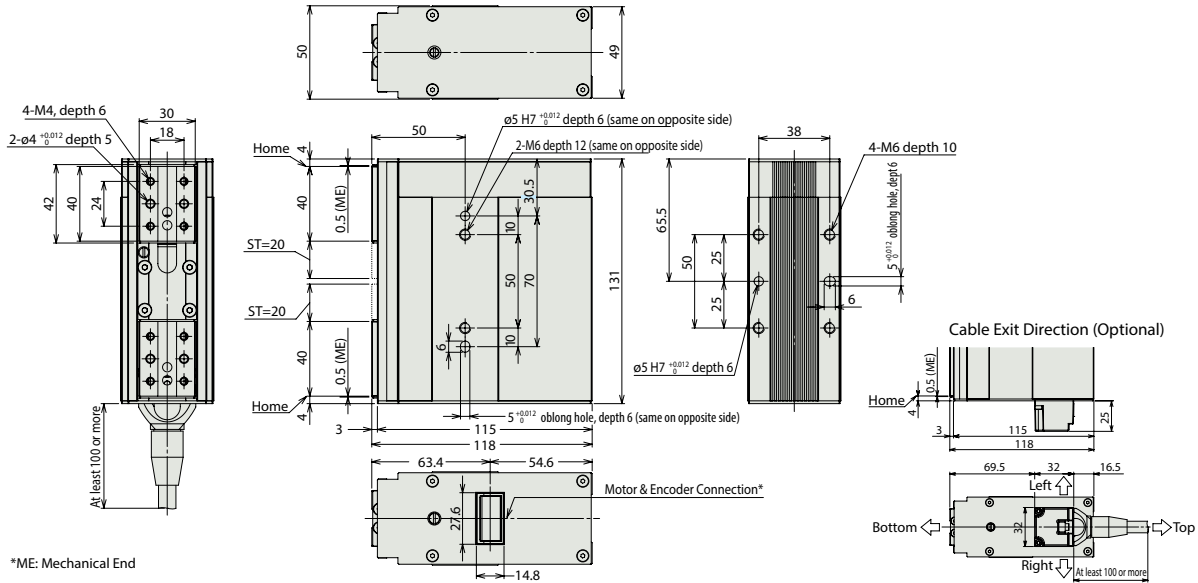







\*ME: Mechanical End

Weight (kg) 1.5

① Applicable Controllers

RCP2 series actuators can be operated with the controllers indicated below. Select the type according to your intended application.

Name	External view	Model number	Features	Maximum number of positioning points	Input power	Power-supply capacity	Standard price	Reference page
Solenoid Valve Type		PMEC-C-42PI-①-2-②	Easy-to-use controller, even for beginners	3 points	AC100V AC200V	Refer to P541	—	→ P537
		PSEP-C-42PI-①-2-0	Simple controller operable with the same signal as a solenoid valve			Refer to P555	—	→ P547
Solenoid valve multi-axis type PIO specification		MSEP-C-③-④-⑤-⑥-⑦-⑧-2-0	Positioner type based on PIO control, allowing up to 8 axes to be connected	256 points	DC24V	Refer to P572	—	→ P563
Solenoid valve multi-axis type Network specification		MSEP-C-③-④-⑤-⑥-⑦-⑧-0-0	Field network-ready positioner type, allowing up to 8 axes to be connected					
Positioner type High-output specification		PCON-CA-42PI-①-2-0	Equipped with a high-output driver Positioner type based on PIO control	512 points	DC24V	Refer to P618	—	→ P607
Pulse-train type High-output specification		PCON-CA-42PI-PL□-2-0	Equipped with a high-output driver Pulse-train input type	(—)				
Field network type High-output specification		PCON-CA-42PI-④-0-0	Equipped with a high-output driver Supporting 7 major field networks	768 points				
Pulse Train Input Type (Differential Line Driver)		PCON-PL-42PI-①-2-0	Pulse train input type with differential line driver support	(—)	DC24V	Refer to P628	—	→ P623
Pulse Train Input Type (Open Collector)		PCON-PO-42PI-①-2-0	Pulse train input type with open collector support					
Serial Communication Type		PCON-SE-42PI-N-0-0	Dedicated Serial Communication	64 points	DC24V	Refer to P671	—	→ P665
Program Control Type		PSEL-CS-1-42PI-①-2-0	Programmed operation is possible. Can operate up to 2 axes	1,500 points	DC24V	Refer to P671	—	→ P665

\* This is for the single-axis PSEL.

\* ① indicates I/O type (NP/PN).

\* ② indicates power supply voltage (1: 100V / 2: 100~240V).

\* ③ indicates number of axes (1 to 8). \* ④ indicates field network specification symbol. \* □ indicates N (NPN specification) or P (PNP specification) symbol.

IAI

RCP2-GRHB

386

Sold & Serviced By:

 ELECTROMATE

Toll Free Phone (877) SERV098

Toll Free Fax (877) SERV099

www.electromate.com

sales@electromate.com

Slider Type

Mini

Standard

Controllers Integrated

Rod Type

Mini

Standard

Controllers Integrated

Table/ Arm/ Flat Type

Mini

Standard

Gripper/ Rotary Type

Linear Servo Type

Clean-room Type

Splash-Proof Type

Pulse Motor

Servo Motor (24V)

Servo Motor (200V)

Linear Servo Motor

# RCP2-GR3LS

ROBO Cylinder, 3-Finger Gripper, Lever Type, Actuator Width 62mm, Pulse Motor

Model Specification Items	<b>RCP2</b> — <b>GR3LS</b> — <b>I</b> — <b>28P</b> — <b>30</b> — <b>19</b> —	<input type="checkbox"/>	<input type="checkbox"/>	<input type="checkbox"/>
	Series — Type — Encoder type — Motor type — Deceleration Ratio — Stroke — Applicable controller — Cable length — Options	I: Incremental * The Simple absolute encoder is also considered type "I".	28P: Pulse motor, 28□ size	30: 1/30 deceleration ratio
		P1: PCON-PL/PO/SE PSEL P3: PCON-CA PMEC/PSEP MSEP	N: None P: 1m S: 3m M: 5m X□□: Custom length R□□: Robot cable	FB: Flange bracket SB: Shaft bracket

\* See page Pre-47 for details on the model descriptions.



Technical References Appendix P.5

- POINT** Notes on selection
- (1) The maximum opening/closing speed indicates the operating speed on one side. The relative operating speed is twice this value.
  - (2) The maximum gripping force is the sum of the gripping forces of all fingers with gripping point distance of 10mm and no overhang distance. For the actual transportable work piece weight, see explanation on the right, or page A-86.
  - (3) The rated acceleration while moving is 0.3G.

### Gripping Force vs. Current Limit

The gripping (pushing) force can be adjusted freely within the range of current limits of 20% to 70%.

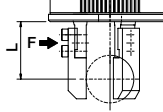

\* Please note that, when gripping (pushing), the speed is fixed at 5 deg/s.

\* The values in the graph below are gripping forces at 10mm gripping point. The actual gripping force decreases inversely proportional to the distance from the opening/closing point.  
You can calculate the actual gripping force by the following equation.

$$\text{Actual gripping force (GR3LS)} = P \times 24 / (L + 14)$$

P = Gripping force on graph

L = Distance from finger mounting surface to the gripping point.

(Operate with the L1 distance under 50mm.)

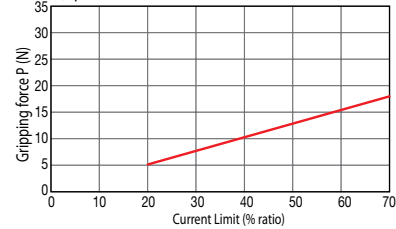

\* The gripping force graph above shows reference numbers. Please allow margins up to ± 15%.

### Actuator Specifications

#### Lead and Payload

Model number	Deceleration Ratio	Maximum Gripping Force (N)	Stroke (deg)
RCP2-GR3LS-I-28P-30-19-①-②-③	30	18 (6 per side)	19

#### Stroke and Max. Opening/Closing Speed

Stroke Deceleration ratio	19 (deg)
30	200

Code explanation ① Applicable Controller ② Cable length ③ Options (Unit: degrees/s)

#### Stroke

Stroke (deg)	Standard price
19	—

#### ② Cable Length

Type	Cable symbol	Standard Price
Standard	P (1m)	—
	S (3m)	—
	M (5m)	—
Special length	X06 (6m) ~ X10 (10m)	—
	X11 (11m) ~ X15 (15m)	—
	X16 (16m) ~ X20 (20m)	—
	R01 (1m) ~ R03 (3m)	—
Robot Cable	R04 (4m) ~ R05 (5m)	—
	R06 (6m) ~ R10 (10m)	—
	R11 (11m) ~ R15 (15m)	—
	R16 (16m) ~ R20 (20m)	—

\* See page A-59 for cables for maintenance.

#### ③ Options

Name	Option code	See page	Standard price
Flange bracket	FB	→ A-43	—
Shaft bracket	SB	→ A-55	—

#### Actuator Specifications

Item	Description
Drive System	Worm gear + worm wheel gear
Positioning repeatability	±0.01 degrees
Backlash	1degree or less per side (constantly pressed out by a spring)
Lost motion	0.15 degrees or less per side
Weight	0.6kg
Ambient operating temperature, humidity	0 to 40°C, 85% RH or less (Non-condensing)

387 RCP2-GR3LS

Dimensional Drawings

For Special Orders Appendix P.15

\* When homing, the actuator swings 1 degree past the home position before returning. Therefore, please watch for any interference with the surrounding objects.  
 (\*1) Connect the motor and encoder cables here. See page A-59 for details on cables.

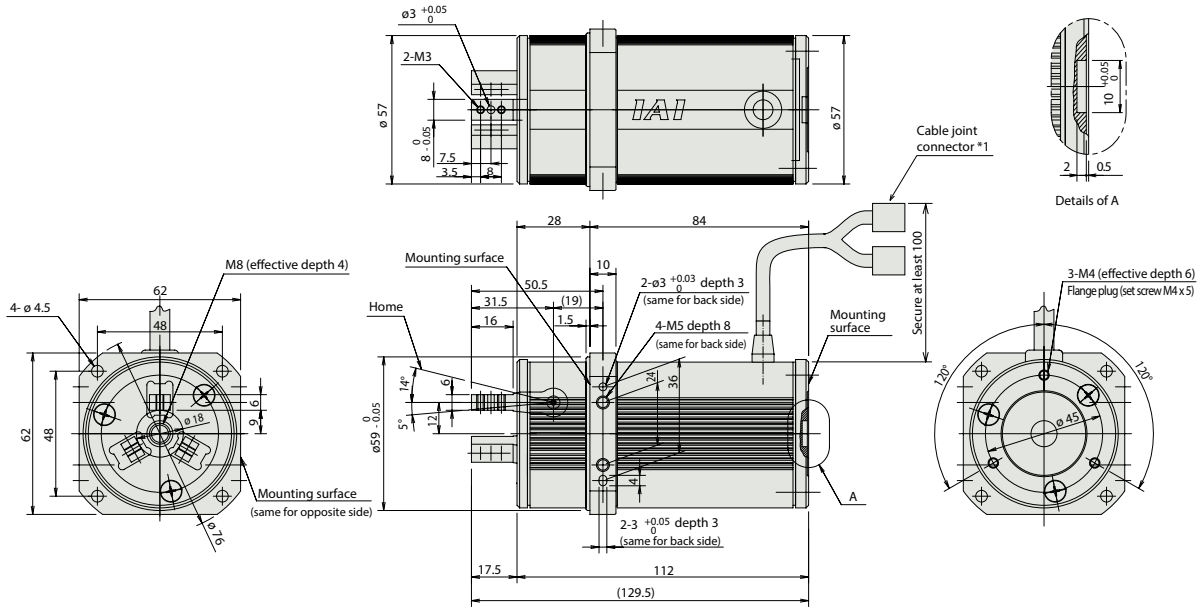

Weight (kg) 0.6

① Applicable Controllers

RCP2 series actuators can be operated with the controllers indicated below. Select the type according to your intended application.

Name	External view	Model number	Features	Maximum number of positioning points	Input power	Power-supply capacity	Standard price	Reference page
Solenoid Valve Type		PMEC-C-28PI-①-2-⑪	Easy-to-use controller, even for beginners	3 points	DC24V	Refer to P541 Refer to P555 Refer to P572 Refer to P618 Refer to P628 Refer to P671	—	→ P537 → P547 → P563 → P607 → P623 → P665
		PSEP-C-28PI-①-2-0	Simple controller operable with the same signal as a solenoid valve					
Solenoid valve multi-axis type PIO specification		MSEP-C-⑪-①-2-0	Positioner type based on PIO control, allowing up to 8 axes to be connected	256 points				
Solenoid valve multi-axis type Network specification		MSEP-C-⑪-①-⑩-0-0	Field network-ready positioner type, allowing up to 8 axes to be connected					
Positioner type High-output specification		PCON-CA-28PI-①-2-0	Equipped with a high-output driver Positioner type based on PIO control	512 points				
Pulse-train type High-output specification		PCON-CA-28PI-PL□-2-0	Equipped with a high-output driver Pulse-train input type	(—)				
Field network type High-output specification		PCON-CA-28PI-⑩-0-0	Equipped with a high-output driver Supporting 7 major field networks	768 points				
Pulse Train Input Type (Differential Line Driver)		PCON-PL-28PI-①-2-0	Pulse train input type with differential line driver support	(—)				
Pulse Train Input Type (Open Collector)		PCON-PO-28PI-①-2-0	Pulse train input type with open collector support					
Serial Communication Type		PCON-SE-28PI-N-0-0	Dedicated Serial Communication	64 points				
Program Control Type		PSEL-CS-1-28PI-①-2-0	Programmed operation is possible. Can operate up to 2 axes	1,500 points				

\* This is for the single-axis PSEL. \* ① indicates I/O type (NP/PN). \* ⑩ indicates power supply voltage (1: 100V / 2: 100~240V).  
 \* ⑪ indicates number of axes (1 to 8). \* ⑩ indicates field network specification symbol. \* □ indicates N (NPN specification) or P (PNP specification) symbol.



RCP2-GR3LS **388**

- Slider Type
- Mini
- Standard
- Controllers Integrated
- Rod Type
- Mini
- Standard
- Controllers Integrated
- Table/Arm/Flat Type
- Mini
- Standard
- Gripper/Rotary Type
- Linear Servo Type
- Clean-room Type
- Splash-Proof Type
- Pulse Motor
- Servo Motor (24V)
- Servo Motor (200V)
- Linear Servo Motor



# RCP2-GR3LM

ROBO Cylinder, 3-Finger Gripper, Lever Type, Actuator Width 80mm, Pulse Motor

Model Specification Items	<b>RCP2-GR3LM-I-42P-30-19</b>	Encoder type	Motor type	Deceleration Ratio	Stroke	Applicable controller	Cable length	Options
		I: Incremental * The Simple absolute encoder is also considered type "I".	42P: Pulse motor, 42□ size	30: 1/30 deceleration ratio	19: 19 degrees	P1: PCON-PL/PO/SE PSEL P3: PCON-CA PMEC/PSEP MSEP	N: None P: 1m S: 3m M: 5m X□□: Custom length R□□: Robot cable	FB: Flange bracket SB: Shaft bracket

\* See page Pre-47 for details on the model descriptions.



Technical References Appendix P.5

- POINT** Notes on selection
- (1) The maximum opening/closing speed indicates the operating speed on one side. The relative operating speed is twice this value.
  - (2) The maximum gripping force is the sum of the gripping forces of all fingers with gripping point distance of 10mm and no overhang distance. For the actual transportable work piece weight, see explanation on the right, or page A-86.
  - (3) The rated acceleration while moving is 0.3G.

### Gripping Force Adjustment

The gripping (pushing) force can be adjusted freely within the range of current limits of 20% to 70%.

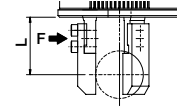

\* Please note that, when gripping (pushing), the speed is fixed at 5 deg/s.

\* The values in the graph below are gripping forces at 10mm gripping point. The actual gripping force decreases inversely proportional to the distance from the opening/closing point.

You can calculate the actual gripping force by the following equation.

$$\text{Actual gripping force (GR3LM)} = P \times 28.5 / (L + 18.5)$$

P = Gripping force on graph

L = Distance from finger mounting surface to the gripping point.

(Operate with the L distance up to 80mm.)

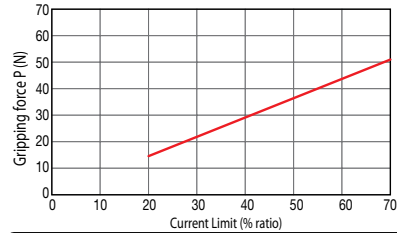

\* The gripping force graph above shows reference numbers. Please allow margins up to ± 15%.

### Actuator Specifications

#### Lead and Payload

Model number	Deceleration Ratio	Maximum Gripping Force (N)	Stroke (deg)
RCP2-GR3LM-I-42P-30-19-①-②-③	30	51 (17 per side)	19

Code explanation ① Applicable Controller ② Cable length ③ Options

#### Stroke and Max. Opening/Closing Speed

Stroke Deceleration ratio	Stroke 19 (deg)
	200

(Unit: degrees/s)

#### Stroke

Stroke (deg)	Standard price
19	—

#### ② Cable Length

Type	Cable symbol	Standard Price
Standard	P (1m)	—
	S (3m)	—
	M (5m)	—
Special length	X06 (6m) ~ X10 (10m)	—
	X11 (11m) ~ X15 (15m)	—
	X16 (16m) ~ X20 (20m)	—
	R01 (1m) ~ R03 (3m)	—
Robot Cable	R04 (4m) ~ R05 (5m)	—
	R06 (6m) ~ R10 (10m)	—
	R11 (11m) ~ R15 (15m)	—
	R16 (16m) ~ R20 (20m)	—

\* See page A-59 for cables for maintenance.

#### ③ Options

Name	Option code	See page	Standard price
Flange bracket	FB	→ A-43	—
Shaft bracket	SB	→ A-55	—

#### Actuator Specifications

Item	Description
Drive System	Worm gear + worm wheel gear
Positioning repeatability	±0.01 degrees
Backlash	1 degree or less per side (constantly pressed out by a spring)
Lost motion	0.15 degrees or less per side
Weight	1.1kg
Ambient operating temperature, humidity	0 to 40°C, 85% RH or less (Non-condensing)

**389** RCP2-GR3LM

Dimensional Drawings

For Special Orders Appendix P.15

\* When homing, the actuator swings 1 degree past the home position before returning. Therefore, please watch for any interference with the surrounding objects.  
 (\*1) Connect the motor and encoder cables here. See page A-59 for details on cables.

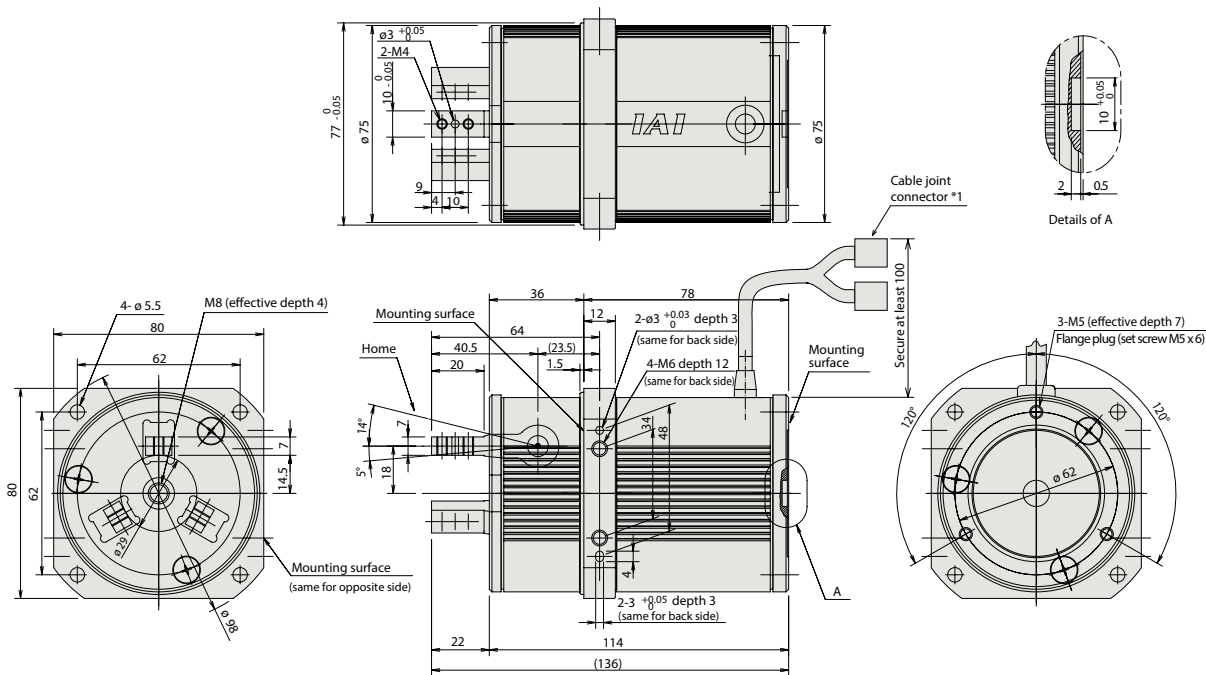

Weight (kg) 1.1

① Applicable Controllers

RCP2 series actuators can be operated with the controllers indicated below. Select the type according to your intended application.

Name	External view	Model number	Features	Maximum number of positioning points	Input power	Power-supply capacity	Standard price	Reference page
Solenoid Valve Type		PMEC-C-42PI-①-2-②	Easy-to-use controller, even for beginners	3 points	AC100V AC200V	Refer to P541	—	→ P537
		PSEP-C-42PI-①-2-0	Simple controller operable with the same signal as a solenoid valve			Refer to P555	—	→ P547
Solenoid valve multi-axis type PIO specification		MSEP-C-④-①-2-0	Positioner type based on PIO control, allowing up to 8 axes to be connected	256 points	DC24V	Refer to P572	—	→ P563
Solenoid valve multi-axis type Network specification		MSEP-C-④-④-0-0	Field network-ready positioner type, allowing up to 8 axes to be connected			—	—	→ P607
Positioner type High-output specification		PCON-CA-42PI-①-2-0	Equipped with a high-output driver Positioner type based on PIO control	512 points	DC24V	Refer to P618	—	→ P607
Pulse-train type High-output specification		PCON-CA-42PI-PL□-2-0	Equipped with a high-output driver Pulse-train input type	(—)		—		
Field network type High-output specification		PCON-CA-42PI-④-0-0	Equipped with a high-output driver Supporting 7 major field networks	768 points		—		
Pulse Train Input Type (Differential Line Driver)		PCON-PL-42PI-①-2-0	Pulse train input type with differential line driver support	(—)	DC24V	Refer to P628	—	→ P623
Pulse Train Input Type (Open Collector)		PCON-PO-42PI-①-2-0	Pulse train input type with open collector support			—	—	
Serial Communication Type		PCON-SE-42PI-N-0-0	Dedicated Serial Communication	64 points	DC24V	Refer to P671	—	→ P665
Program Control Type		PSEL-CS-1-42PI-①-2-0	Programmed operation is possible. Can operate up to 2 axes	1,500 points	DC24V	Refer to P671	—	→ P665

\* This is for the single-axis PSEL. \* ① indicates I/O type (NP/PN). \* ② indicates power supply voltage (1: 100V / 2: 100~240V).  
 \* ④ indicates number of axes (1 to 8). \* ④ indicates field network specification symbol. \* □ indicates N (NPN specification) or P (PNP specification) symbol.



RCP2-GR3LM **390**

- Slider Type
- Mini
- Standard
- Controllers Integrated
- Rod Type
- Mini
- Standard
- Controllers Integrated
- Table/ Arm/ Flat Type
- Mini
- Standard
- Gripper/ Rotary Type
- Linear Servo Type
- Clean-room Type
- Splash-Proof Type
- Pulse Motor
- Servo Motor (24V)
- Servo Motor (200V)
- Linear Servo Motor



# RCP2-GR3SS

ROBO Cylinder, 3-Finger Gripper, Slider Type, Actuator Width 62mm, Pulse Motor

Model Specification Items	<b>RCP2</b>	<b>GR3SS</b>	<b>I</b>	<b>28P</b>	<b>30</b>	<b>10</b>	<input type="checkbox"/>	<input type="checkbox"/>	<input type="checkbox"/>
	Series	Type	Encoder type	Motor type	Deceleration Ratio	Stroke	Applicable controller	Cable length	Options
			I: Incremental * The Simple absolute encoder is also considered type "I".	28P: Pulse motor, 28□ size	30: 1/30 deceleration ratio	10: 10mm (5mm per side)	P1: PCON-PL/PO/SE PSEL P3: PCON-CA PMEC/PSEP MSEP	N: None P: 1m S: 3m M: 5m X□□: Custom length R□□: Robot cable	FB: Flange bracket SB: Shaft bracket

\* See page Pre-47 for details on the model descriptions.



Technical References Appendix P.5

- POINT**  
Notes on selection
- (1) The maximum opening/closing speed indicates the operating speed on one side. The relative operating speed is twice this value.
  - (2) The maximum gripping force is the sum of the gripping forces of all fingers with gripping point distance of 10mm and no overhang distance. For the actual transportable work piece weight, see explanation on the right, or page A-86.
  - (3) The rated acceleration while moving is 0.3G.

### Gripping Force vs. Current Limit

The gripping (pushing) force can be adjusted freely within the range of current limits of 20% to 70%.

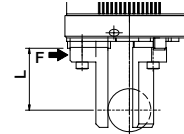

\* Please note that, when gripping (pushing), the speed is fixed at 5mm/s.

\* Operate with the L distance up to 50mm.  
\* The gripping force value in the graph below is when L is at 0 mm. (For gripping force reference per L distance, see page A-87.)  
The gripping force value is the sum of gripping forces of both fingers.

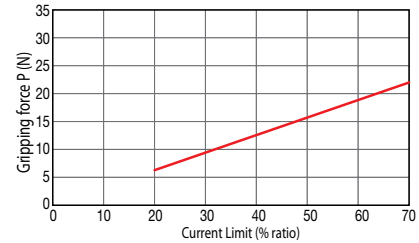

\* The gripping force graph above shows reference numbers. Please allow margins up to ± 15%.

### Actuator Specifications

#### Lead and Payload

Model number	Deceleration Ratio	Maximum Gripping Force (N)	Stroke (mm)
RCP2-GR3SS-I-28P-30-10-①-②-③	30	22 (7.3 per side)	10

Code explanation ① Applicable Controller ② Cable length ③ Options

#### Stroke and Max. Opening/Closing Speed

Deceleration ratio	Stroke	10 (mm)
	30	40

(Unit: mm/s)

#### Stroke

Stroke (mm)	Standard price
10	—

#### ② Cable Length

Type	Cable symbol	Standard Price
Standard	P (1m)	—
	S (3m)	—
	M (5m)	—
Special length	X06 (6m) ~ X10 (10m)	—
	X11 (11m) ~ X15 (15m)	—
	X16 (16m) ~ X20 (20m)	—
Robot Cable	R01 (1m) ~ R03 (3m)	—
	R04 (4m) ~ R05 (5m)	—
	R06 (6m) ~ R10 (10m)	—
	R11 (11m) ~ R15 (15m)	—
	R16 (16m) ~ R20 (20m)	—
	R16 (16m) ~ R20 (20m)	—

\* See page A-59 for cables for maintenance.

#### ③ Options

Name	Option code	See page	Standard price
Flange bracket	FB	→ A-43	—
Shaft bracket	SB	→ A-55	—

#### Actuator Specifications

Item	Description
Drive System	Worm gear + worm wheel gear
Positioning repeatability	±0.01mm
Backlash	0.3mm or less per side (constantly pressed out by a spring)
Lost motion	0.1mm or less per side
Guide	Cross roller guide
Allowable static load moment	Ma: 3.8 N·m, Mb: 3.8 N·m, Mc: 3.0 N·m
Weight	0.6kg
Ambient operating temperature, humidity	0 to 40°C, 85% RH or less (Non-condensing)

# 391

RCP2-GR3SS

Dimensional Drawings

For Special Orders Appendix P.15

\* When homing, the actuator swings 0.5mm past the home position before returning. Therefore, please watch for any interference with the surrounding objects.  
 (\*1) Connect the motor and encoder cables here. See page A-59 for details on cables.

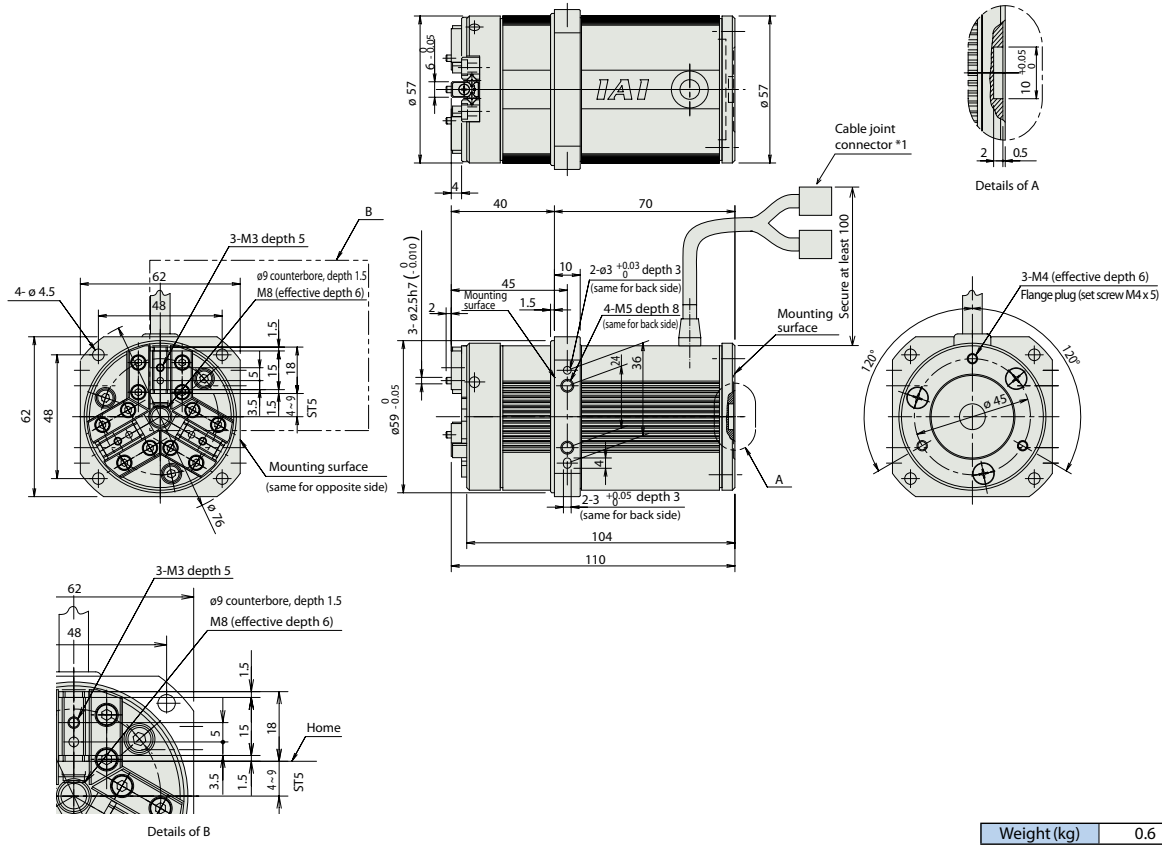

Weight (kg) 0.6

① Applicable Controllers

RCP2 series actuators can be operated with the controllers indicated below. Select the type according to your intended application.

Name	External view	Model number	Features	Maximum number of positioning points	Input power	Power-supply capacity	Standard price	Reference page
Solenoid Valve Type		PMEC-C-28PI-(1)-2-(1)	Easy-to-use controller, even for beginners	3 points	AC100V AC200V	Refer to P541	—	→ P537
		PSEP-C-28PI-(1)-2-0	Simple controller operable with the same signal as a solenoid valve			Refer to P555	—	→ P547
Solenoid valve multi-axis type PIO specification		MSEP-C-(1)-(1)-2-0	Positioner type based on PIO control, allowing up to 8 axes to be connected	256 points	DC24V	Refer to P572	—	→ P563
Solenoid valve multi-axis type Network specification		MSEP-C-(1)-(V)-0-0	Field network-ready positioner type, allowing up to 8 axes to be connected					
Positioner type High-output specification		PCON-CA-28PI-(1)-2-0	Equipped with a high-output driver Positioner type based on PIO control	512 points	DC24V	Refer to P618	—	→ P607
Pulse-train type High-output specification		PCON-CA-28PI-PL□-2-0	Equipped with a high-output driver Pulse-train input type	(—)				
Field network type High-output specification		PCON-CA-28PI-(V)-0-0	Equipped with a high-output driver Supporting 7 major field networks	768 points				
Pulse Train Input Type (Differential Line Driver)		PCON-PL-28PI-(1)-2-0	Pulse train input type with differential line driver support	(—)	DC24V	Refer to P628	—	→ P623
Pulse Train Input Type (Open Collector)		PCON-PO-28PI-(1)-2-0	Pulse train input type with open collector support					
Serial Communication Type		PCON-SE-28PI-N-0-0	Dedicated Serial Communication	64 points	DC24V	Refer to P671	—	→ P665
Program Control Type		PSEL-CS-1-28PI-(1)-2-0	Programmed operation is possible. Can operate up to 2 axes	1,500 points	DC24V	Refer to P671	—	→ P665

\* This is for the single-axis PSEL. \* ① indicates I/O type (NP/PN). \* ① indicates power supply voltage (1: 100V / 2: 100~240V).  
 \* ① indicates number of axes (1 to 8). \* ① indicates field network specification symbol. \* □ indicates N (NPN specification) or P (PNP specification) symbol.



RCP2-GR3SS

392

- Slider Type
- Mini
- Standard
- Controllers Integrated
- Rod Type
- Mini
- Standard
- Controllers Integrated
- Table/Arm/Flat Type
- Mini
- Standard
- Gripper/Rotary Type
- Linear Servo Type
- Clean-room Type
- Splash-Proof Type
- Pulse Motor
- Servo Motor (24V)
- Servo Motor (200V)
- Linear Servo Motor

# RCP2-GR3SM

ROBO Cylinder, 3-Finger Gripper, Slider Type, Actuator Width 80mm, Pulse Motor

Model Specification Items	<b>RCP2</b>	<b>GR3SM</b>	<b>I</b>	<b>42P</b>	<b>30</b>	<b>14</b>	<input type="checkbox"/>	<input type="checkbox"/>	<input type="checkbox"/>
	Series	Type	Encoder type	Motor type	Deceleration Ratio	Stroke	Applicable controller	Cable length	Options
			I: Incremental * The Simple absolute encoder is also considered type "I".	42P: Pulse motor, 42□ size	30: 1/30 deceleration ratio	14: 14mm (7mm per side)	P1: PCON-PL/PO/SE PSEL P3: PCON-CA PMEC/PSEP MSEP	N: None P: 1m S: 3m M: 5m X□□: Custom length R□□: Robot cable	FB: Flange bracket SB: Shaft bracket

\* See page Pre-47 for details on the model descriptions.



Technical References Appendix P.5

- POINT** Notes on selection
- (1) The maximum opening/closing speed indicates the operating speed on one side. The relative operating speed is twice this value.
  - (2) The maximum gripping force is the sum of the gripping forces of all fingers with gripping point distance of 10mm and no overhang distance. For the actual transportable work piece weight, see explanation on the right, or page A-86.
  - (3) The rated acceleration while moving is 0.3G.

### Gripping Force vs. Current Limit

The gripping (pushing) force can be adjusted freely within the range of current limits of 20% to 70%.

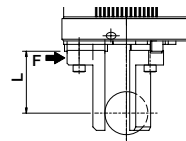

\* Please note that, when gripping (pushing), the speed is fixed at 5mm/s.

\* Operate with the L distance up to 80mm.  
\* The gripping force value in the graph below is when L is at 0 mm. (For gripping force reference per L distance, see page A-87.)  
The gripping force value is the sum of gripping forces of both fingers.

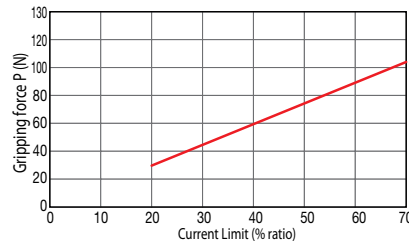

\* The gripping force graph above shows reference numbers. Please allow margins up to ± 15%.

### Actuator Specifications

#### Lead and Payload

Model number	Deceleration Ratio	Maximum Gripping Force (N)	Stroke (mm)
RCP2-GR3SM-I-42P-30-14-①-②-③	30	102 (34 per side)	14

Code explanation ① Applicable Controller ② Cable length ③ Options

#### Stroke and Max. Opening/Closing Speed

Deceleration ratio	Stroke	14 (mm)
	30	50

(Unit: mm/s)

#### Stroke

Stroke (mm)	Standard price
14	—

#### ② Cable Length

Type	Cable symbol	Standard Price
Standard	P (1m)	—
	S (3m)	—
	M (5m)	—
Special length	X06 (6m) ~ X10 (10m)	—
	X11 (11m) ~ X15 (15m)	—
	X16 (16m) ~ X20 (20m)	—
	R01 (1m) ~ R03 (3m)	—
Robot Cable	R04 (4m) ~ R05 (5m)	—
	R06 (6m) ~ R10 (10m)	—
	R11 (11m) ~ R15 (15m)	—
	R16 (16m) ~ R20 (20m)	—

\* See page A-59 for cables for maintenance.

#### ③ Options

Name	Option code	See page	Standard price
Flange bracket	FB	→ A-43	—
Shaft bracket	SB	→ A-55	—

#### Actuator Specifications

Item	Description
Drive System	Worm gear + worm wheel gear
Positioning repeatability	±0.01mm
Backlash	0.3mm or less per side (constantly pressed out by a spring)
Lost motion	0.1mm or less per side
Guide	Cross roller guide
Allowable static load moment	Ma: 6.3 N·m, Mb: 6.3 N·m, Mc: 5.7 N·m
Weight	1.2kg
Ambient operating temperature, humidity	0 to 40°C, 85% RH or less (Non-condensing)

**393** RCP2-GR3SM

Dimensional Drawings

For Special Orders  Appendix P.15



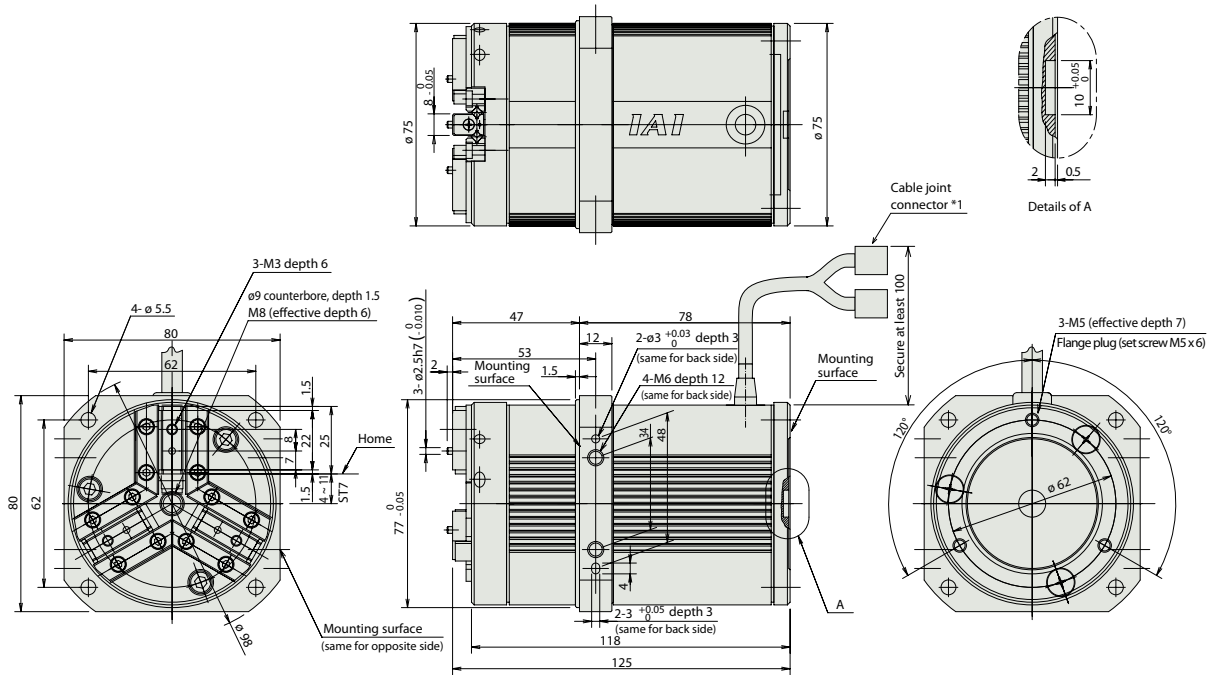



\* When homing, the actuator swings 0.5mm past the home position before returning. Therefore, please watch for any interference with the surrounding objects.  
 (\*1) Connect the motor and encoder cables here. See page A-59 for details on cables.



Weight (kg) 1.2

① Applicable Controllers

RCP2 series actuators can be operated with the controllers indicated below. Select the type according to your intended application.

Name	External view	Model number	Features	Maximum number of positioning points	Input power	Power-supply capacity	Standard price	Reference page
Solenoid Valve Type		PMEC-C-42PI-①-2-①	Easy-to-use controller, even for beginners	3 points	DC24V	Refer to P541	—	→ P537
		PSEP-C-42PI-①-2-0	Simple controller operable with the same signal as a solenoid valve			Refer to P555	—	→ P547
Solenoid valve multi-axis type PIO specification		MSEP-C-④-④-①-2-0	Positioner type based on PIO control, allowing up to 8 axes to be connected	256 points		Refer to P572	—	→ P563
Solenoid valve multi-axis type Network specification		MSEP-C-④-④-④-0-0	Field network-ready positioner type, allowing up to 8 axes to be connected			—	—	→ P607
Positioner type High-output specification		PCON-CA-42PI-①-2-0	Equipped with a high-output driver Positioner type based on PIO control	512 points		Refer to P618	—	→ P607
Pulse-train type High-output specification		PCON-CA-42PI-PL□-2-0	Equipped with a high-output driver Pulse-train input type	(—)		—	—	
Field network type High-output specification		PCON-CA-42PI-④-0-0	Equipped with a high-output driver Supporting 7 major field networks	768 points		—	—	
Pulse Train Input Type (Differential Line Driver)		PCON-PL-42PI-①-2-0	Pulse train input type with differential line driver support	(—)		Refer to P628	—	→ P623
Pulse Train Input Type (Open Collector)		PCON-PO-42PI-①-2-0	Pulse train input type with open collector support					
Serial Communication Type		PCON-SE-42PI-N-0-0	Dedicated Serial Communication	64 points	—	—	—	
Program Control Type		PSEL-CS-1-42PI-①-2-0	Programmed operation is possible. Can operate up to 2 axes	1,500 points	Refer to P671	—	→ P665	

\* This is for the single-axis PSEL. \* ① indicates I/O type (NP/PN). \* ④ indicates power supply voltage (1: 100V / 2: 100~240V). \* ④ indicates number of axes (1 to 8). \* ④ indicates field network specification symbol. \* □ indicates N (NPN specification) or P (PNP specification) symbol.



RCP2-GR3SM

394

- Slider Type
- Mini
- Standard
- Controllers Integrated
- Rod Type
- Mini
- Standard
- Controllers Integrated
- Table/ Arm/ Flat Type
- Mini
- Standard
- Gripper/ Rotary Type
- Linear Servo Type
- Clean-room Type
- Splash-Proof Type
- Pulse Motor
- Servo Motor (24V)
- Servo Motor (200V)
- Linear Servo Motor

# RCS2-GR8

ROBO Cylinder, 2-Finger Gripper, Long Stroke Slider Type, Actuator Width 104 ~ 284mm, 200V servo Motor

Model Specification Items	<b>RCP2</b> — <b>GR8</b> — <b>I</b> — <b>60</b> — <b>5</b> — <input type="checkbox"/> — <input type="checkbox"/> — <input type="checkbox"/> — <input type="checkbox"/>	Series	Type	Encoder type	Motor type	Deceleration Ratio	Stroke	Applicable controller	Cable length	Options
	I: Incremental	60: 60W Servo motor	5:1/5	20: 20mm 40: 40mm (60): 60mm (80): 80mm 100: 100mm (120): 120mm (200): 200mm	T1: XSEL-J/K T2: SCON MSCON SSEL XSEL-P/Q XSEL-R/S	N: None P: 1m S: 3m M: 5m X <input type="checkbox"/> : Custom length R <input type="checkbox"/> : Robot cable	See Options below.			

\* See page Pre-47 for details on the model descriptions.



\*CE compliance is optional.

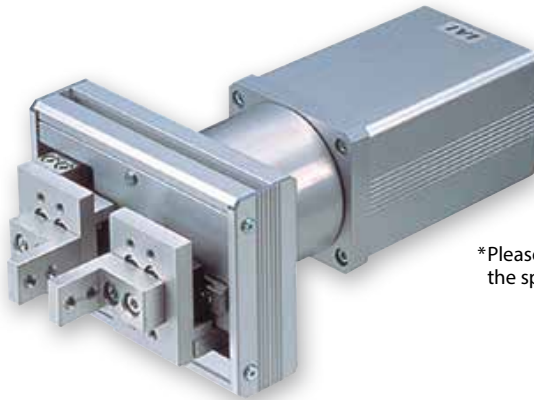

\*Please note that, when gripping (pressing), the speed is fixed at 10mm/s

Technical References Appendix P.5

**POINT** Notes on selection

(1) Stroke values enclosed in "( )" are (60, 80, 120, 200) are semi-standard models.  
 (2) The maximum gripping force is the sum of both fingers.

### Actuator Specifications

#### Lead and Payload

Model number	Motor Output (W)	Deceleration Ratio	Gripping force at a stop (N) (Note 1)	Rated gripping force at a travel (N) (Note 2)	Stroke (mm)
RCS2-GR8-I-60-5-①-②-③-④	60	1/5	22.5 (11.25 per side)	31.3 (15.65 per side)	20, 40, (60), (80), 100, (120), (200)

Code explanation ① Stroke ② Applicable controller ③ Cable length ④ Options

(Note 1) The value of allowable load at a stop  
 (Note 2) The value of allowable load when fingers are traveling

#### ① Stroke

① Stroke (mm)	Standard price
20	—
40	—
(60)	—
(80)	—
100	—
(120)	—
(200)	—

#### ③ Cable Length

Type	Cable symbol	Standard Price
Standard	<b>P</b> (1m)	—
	<b>S</b> (3m)	—
	<b>M</b> (5m)	—
Special length	<b>X06</b> (6m) ~ <b>X10</b> (10m)	—
	<b>X11</b> (11m) ~ <b>X15</b> (15m)	—
	<b>X16</b> (16m) ~ <b>X20</b> (20m)	—
	<b>R01</b> (1m) ~ <b>R03</b> (3m)	—
Robot Cable	<b>R04</b> (4m) ~ <b>R05</b> (5m)	—
	<b>R06</b> (6m) ~ <b>R10</b> (10m)	—
	<b>R11</b> (11m) ~ <b>R15</b> (15m)	—
	<b>R16</b> (16m) ~ <b>R20</b> (20m)	—

\* See page A-59 for cables for maintenance.

#### ④ Options

Name	Option code	See page	Standard price
CE compliance	<b>CE</b>	→ A-42	—

#### Actuator Specifications

Item	Description
Drive System	Rack and pinion
Positioning repeatability	±0.04mm
Lost motion	0.7mm or less per side
Base	Material: Aluminum, white alumite treated
Allowable static load moment	Ma: 5.1 N·m, Mb: 5.1 N·m, Mc: 10.4 N·m
Ambient operating temperature, humidity	0 to 40°C, 85% RH or less (Non-condensing)

# 395

RCS2-GR8

Dimensional Drawings

For Special Orders  Appendix P.15

\*The opening side of the slider is the home position.

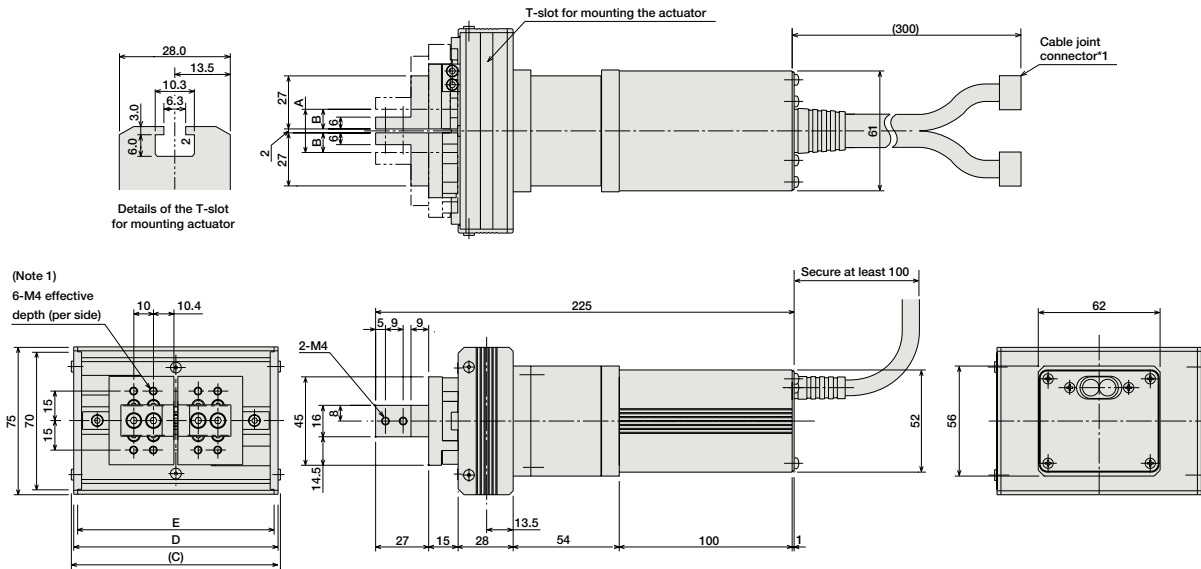

(Note 1)

6-M4 effective depth (per side)

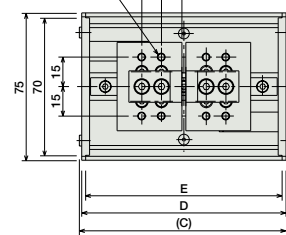

(\*1) Connect the motor and encoder cables here. See page A-59 for details on cables.

(Note 1) The number of tapped holes on the finger mounting plate is for one side. In addition, by default, each finger is secured using 2 tapped holes





■ Dimensions and Weight by Stroke

Stroke	20	40	(60)	(80)	100	(120)	(200)
A	22	42	62	82	102	122	202
B	10	20	30	40	50	60	100
C	106.4	126.4	146.4	166.4	186.4	206.4	286.4
D	104	124	144	164	184	204	284
E	100	120	140	160	180	200	280
Weight (kg)	1.8	1.9	1.9	2.0	2.0	2.1	2.3

\*1 The strokes enclosed in "( )" are semi-standard configurations, and will require longer delivery time.

② Applicable Controllers

RCS2-series actuators can be operated with the following controllers. Select an appropriate controller type according to your application.

Name	External view	Model number	Features	Maximum number of positioning points	Input power	Power supply capacity	Standard price	Reference page		
Positioner mode		SCON-CA-60I-NP-2-①	Up to 512 positioning points are supported.	512 points	Single-phase 100VAC Single-phase 200VAC 3-phase 200VAC (XSEL-P/Q/R/S ONLY)	218 VA max. *Power supply capacity will vary depending on the controller, so please refer to the instruction manual for details.	—	→ P643		
Solenoid valve mode			Actuators can be operated through the same control used for solenoid valves.	7 points						
Field network type			Movement by numerical specification is supported.	768 points						
Pulse-train input control type			Dedicated pulse-train input type	(-)						
Positioner multi-axis, network type		MCON-C-1-60I-V-0-①	Up to 6 axes can be operated. Movement by numerical specification is supported.	256 points	3-phase 200VAC (XSEL-P/Q/R/S ONLY)	218 VA max. *Power supply capacity will vary depending on the controller, so please refer to the instruction manual for details.	—	→ P655		
Program control type, 1 to 2 axes		SSEL-CS-1-60I-NP-2-①	Program operation is supported. Up to 2 axes can be operated.	20,000 points					—	→ P685
Program control type, 1 to 8 axes		XSEL-①-1-60I-N1-EEE-2-③	Program operation is supported. Up to 8 axes can be operated.	Varies depending on the number of axis connected					—	→ P695

\* This is for the single-axis MCON, SSEL, and XSEL.

\* ① indicates the XSEL type (J / K / P / Q / R / S).

\* ③ indicates field network specification symbol.

\* ① indicates the power-supply voltage type (1: 100 V / 2: Single-phase 200 V).

\* ③ indicates the power-supply voltage type (1: 100 V / 2: Single-phase 200 V / 3: Three-phase 200 V).

Slider Type

Mini

Standard

Controllers Integrated

Rod Type

Mini

Standard

Controllers Integrated

Table/ Arm/ Flat Type

Mini

Standard

Gripper/ Rotary Type

Linear Servo Type

Clean-room Type

Splash-Proof Type

Pulse Motor

Servo Motor (24V)

Servo Motor (200V)

Linear Servo Motor



# RCP2-RTBS/RTBSL

ROBO Cylinder, Rotary, Small Vertical Type, Actuator Width 45mm, Pulse Motor

Model Specification Items	<b>RCP2</b>	<b>I</b>	<b>20P</b>					
	Series	Type	Encoder type	Motor type	Deceleration Ratio	Oscillation Angle	Applicable controller	Cable length
	RTBS: 330-deg rotation RTBSL: Multiple rotation	I: Incremental * The Simple absolute encoder is also considered type "I".	20P: Pulse motor, 20□ size	30: 1/30 deceleration ratio 45: 1/45 deceleration ratio	330: 330-degrees (RTBS only) 360: 360-degrees (RTBSL only)	P1: PCON-PL/PO/SE PSEL P3: PCON-CA PMEC/PSEP MSEP	N: None P: 1m S: 3m M: 5m X□□: Custom length	NM: Non-motor end SA: Shaft adapter TA: Table adapter

\* See page Pre-47 for details on the model descriptions.



Technical References Appendix P.5

- POINT** Notes on selection
- (1) The output torque decreases as the rotational speed increases. Check the Output Torque graph on the right to see whether the speed required for your desired motion is supported.
  - (2) The allowable moment of inertia of the rotated work piece varies with the rotational speed. Check the Allowable Moment of Inertia graph on the right to see if the moment of inertia required for your desired motion is within the allowable range.
  - (3) The rated acceleration while moving is 0.2G.
  - (4) Please note that the PMEC/PSEP controllers cannot be used when performing infinite rotation with the multiple rotation type.

**Speed vs. Load Capacity**  
Due to the characteristics of the pulse motor, the RCP2 series' load capacity decreases at high speeds. In the table below, check if your desired speed and load capacity are supported.

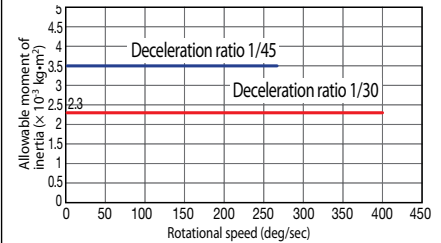
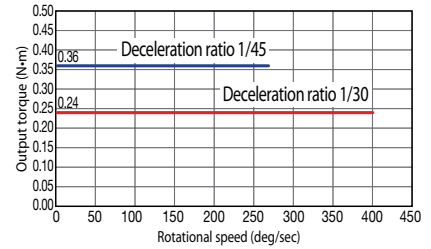

**Actuator Specifications**

**Leads and Payload**

Model number	Deceleration Ratio	Max. Torque (N·m)	Allowable Movement of Inertia (kg·m <sup>2</sup> )	Oscillation Angle (deg)
RCP2-RTBS-I-20P-30-330-①-②-③	1/30	0.24	0.0023	330
RCP2-RTBS-I-20P-45-330-①-②-③	1/45	0.36	0.0035	
RCP2-RTBSL-I-20P-30-360-①-②-③	1/30	0.24	0.0023	360
RCP2-RTBSL-I-20P-45-360-①-②-③	1/45	0.36	0.0035	

**Deceleration Ratio and Max. Speed**

Deceleration ratio	Stroke	330/360 (deg)
	1/30	400
1/45	266	266

(Unit: degrees/s)

Code explanation ① Applicable Controller ② Cable Length ③ Options

**Stroke**

Type	Oscillation Angle (deg)	Standard price
RTBS	330	—
RTBSL	360	—

**Cable Length**

Type	Cable symbol	Standard Price
Standard (Robot Cables)	P (1m)	—
	S (3m)	—
	M (5m)	—
Special length	X06 (6m) ~ X10 (10m)	—
	X11 (11m) ~ X15 (15m)	—
	X16 (16m) ~ X20 (20m)	—
	—	—

\* The standard cable is the motor-encoder integrated robot cable.  
\* See page A-59 for cables for maintenance.

**Options**

Name	Option code	See page	Standard price
Reversed-rotation	NM	→ A-52	—
Shaft adapter	SA	→ A-54	—
Table adapter	TA	→ A-56	—

**Actuator Specifications**

Item	Description
Drive System	Hypoid gear
Positioning repeatability	±0.05 degrees
Homing accuracy	±0.05 degrees
Lost motion	±0.1 degrees
Allowable thrust load	30N
Allowable load moment	3.6 N·m
Weight	0.52kg
Ambient operating temperature, humidity	0 to 40°C, 85% RH or less (Non-condensing)

**397** RCP2-RTBS/RTBSL

- Slider Type
- Mini
- Standard
- Controllers Integrated
- Rod Type
- Mini
- Standard
- Controllers Integrated
- Table/ Arm/ Flat Type
- Mini
- Standard
- Gripper/ Rotary Type
- Linear Servo Type
- Clean-room Type
- Splash-Proof Type
- Pulse Motor
- Servo Motor (24V)
- Servo Motor (200V)
- Linear Servo Motor

Dimensional Drawings

For Special Orders  Appendix P.15

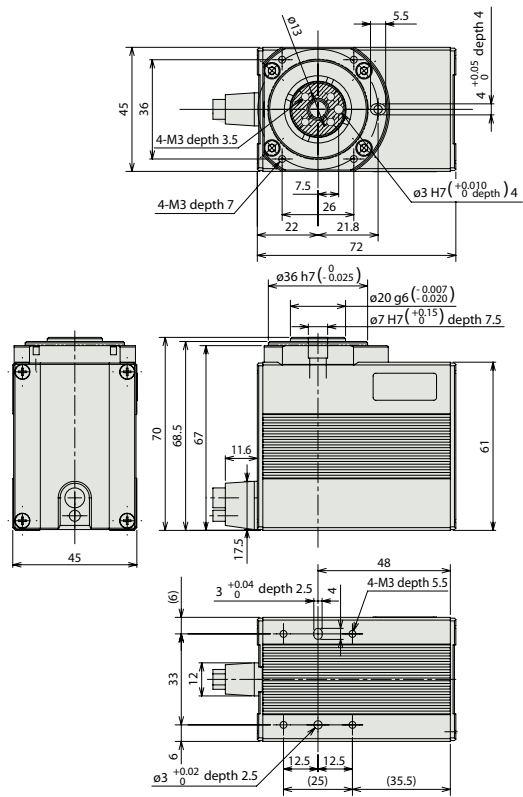

Note:  
\* In the 2D drawing on the left, the shaded area indicates the rotating part.

(\*1) Connect the motor-encoder integrated cable here. See page A-59 for details on cables.

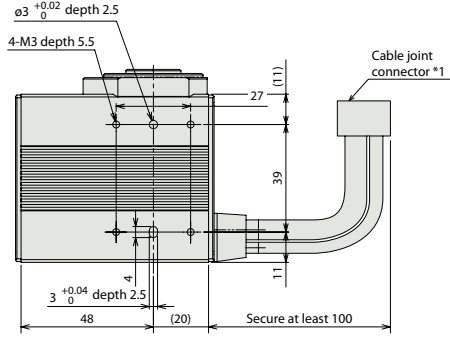

Note:  
The position shown in the top view of the drawing is the home position for both the standard type and reversed rotation type (Option "NM"). Looking from above, the standard type will rotate counter clockwise during homing, and it then moves clockwise afterward. The reverse rotation type will move clockwise during homing and then moves counter clockwise afterward. Please be aware that the homing direction cannot be changed after shipment. Please refer to the Appendix for the details.

Weight (kg) 0.52

① Applicable Controllers

RCP2 series actuators can be operated with the controllers indicated below. Select the type according to your intended application.

Name	External view	Model number	Features	Maximum number of positioning points	Input power	Power-supply capacity	Standard price	Reference page
Solenoid Valve Type		PMEC-C-20PI-①-2-②	Easy-to-use controller, even for beginners	3 points	AC100V AC200V	Refer to P541	—	→ P537
		PSEP-C-20PI-①-2-0	Simple controller operable with the same signal as a solenoid valve					
Solenoid valve multi-axis type PIO specification		MSEP-C-①①①-①-2-0	Positioner type based on PIO control, allowing up to 8 axes to be connected	256 points	DC24V	Refer to P572	—	→ P563
Solenoid valve multi-axis type Network specification		MSEP-C-①①①-④-0-0	Field network-ready positioner type, allowing up to 8 axes to be connected					
Positioner type High-output specification		PCON-CA-20PI-①-2-0	Equipped with a high-output driver Positioner type based on PIO control	512 points	DC24V	Refer to P618	—	→ P607
Pulse-train type High-output specification		PCON-CA-20PI-PL□-2-0	Equipped with a high-output driver Pulse-train input type	(—)				
Field network type High-output specification		PCON-CA-20PI-④-0-0	Equipped with a high-output driver Supporting 7 major field networks	768 points				
Pulse Train Input Type (Differential Line Driver)		PCON-PL-20PI-①-2-0	Pulse train input type with differential line driver support	(—)	DC24V	Refer to P628	—	→ P623
Pulse Train Input Type (Open Collector)		PCON-PO-20PI-①-2-0	Pulse train input type with open collector support					
Serial Communication Type		PCON-SE-20PI-N-0-0	Dedicated Serial Communication	64 points	DC24V	Refer to P671	—	→ P665
Program Control Type		PSEL-CS-1-20PI-①-2-0	Programmed operation is possible. Can operate up to 2 axes	1,500 points	DC24V	Refer to P671	—	→ P665

\* This is for the single-axis PSEL. \* ① indicates I/O type (NP/PN). \* ② indicates power supply voltage (1: 100V / 2: 100~240V). \* ①①① indicates number of axes (1 to 8). \* ④ indicates field network specification symbol. \* □ indicates N (NPN specification) or P (PNP specification) symbol.

- Slider Type
- Mini
- Standard
- Controllers Integrated
- Rod Type
- Mini
- Standard
- Controllers Integrated
- Table/Arm/Flat Type
- Mini
- Standard
- Gripper/Rotary Type
- Linear Servo Type
- Clean-room Type
- Splash-Proof Type
- Pulse Motor
- Servo Motor (24V)
- Servo Motor (200V)
- Linear Servo Motor



RCP2-RTBS/RTBSL **398**



# RCP2-RTCS/RTCSL

ROBO Cylinder, Rotary, Small Flat Type, Actuator Width 72mm, Pulse Motor

Model Specification Items	<b>RCP2</b> — <input type="checkbox"/> — <b>I</b> — <b>20P</b> — <input type="checkbox"/> — <input type="checkbox"/> — <input type="checkbox"/> — <input type="checkbox"/> — <input type="checkbox"/>
	Series — Type — Encoder type — Motor type — Deceleration Ratio — Oscillation Angle — Applicable controller — Cable length — Options
	RTCS: 330-deg rotation RTCSL: Multiple rotation I: Incremental * The Simple absolute encoder is also considered type "I". 20P: Pulse motor, 20□ size 30: 1/30 deceleration ratio 45: 1/45 deceleration ratio 330: 330-degrees (RTCS only) 360: 360-degrees (RTCSL only) P1: PCON-PL/PO/SE PSEL P3: PCON-CA PMEC/PSEP MSEP N: None P: 1m S: 3m M: 5m X□□: Custom length NM: Non-motor end SA: Shaft adapter TA: Table adapter

\* See page Pre-47 for details on the model descriptions.



Technical References Appendix P.5

- POINT** Notes on selection
- (1) The output torque decreases as the rotational speed increases. Check the Output Torque graph on the right to see whether the speed required for your desired motion is supported.
  - (2) The allowable moment of inertia of the rotated work piece varies with the rotational speed. Check the Allowable Moment of Inertia graph on the right to see if the moment of inertia required for your desired motion is within the allowable range.
  - (3) The rated acceleration while moving is 0.2G.
  - (4) Please note that the PMEC/PSEP controllers cannot be used when performing infinite rotation with the multiple rotation type.

### Speed vs. Load Capacity

Due to the characteristics of the pulse motor, the RCP2 series' load capacity decreases at high speeds. In the table below, check if your desired speed and load capacity are supported.

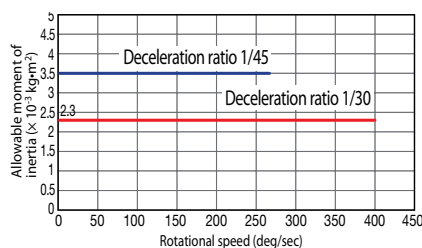
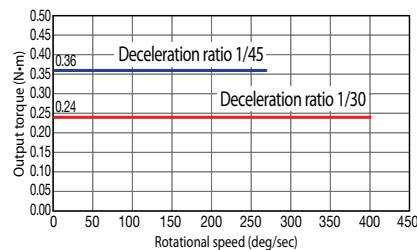

### Actuator Specifications

#### Leads and Payload

Model number	Deceleration Ratio	Max. Torque (N·m)	Allowable Movement of Inertia (kg·m <sup>2</sup> )	Oscillation Angle (deg)
RCP2-RTCS-I-20P-30-330-①-②-③	1/30	0.24	0.0023	330
RCP2-RTCS-I-20P-45-330-①-②-③	1/45	0.36	0.0035	
RCP2-RTCSL-I-20P-30-360-①-②-③	1/30	0.24	0.0023	360
RCP2-RTCSL-I-20P-45-360-①-②-③	1/45	0.36	0.0035	

Code explanation ① Applicable Controller ② Cable Length ③ Options

#### Deceleration Ratio and Max. Speed

Deceleration ratio	Stroke	330/360 (deg)
	1/30	400
1/45	266	266

(Unit: degrees/s)

#### Stroke

Type	Oscillation Angle (deg)	Standard price
RTCS	330	—
RTCSL	360	—

#### Cable Length

Type	Cable symbol	Standard Price
Standard (Robot Cables)	P (1m)	—
	S (3m)	—
	M (5m)	—
Special length	X06 (6m) ~ X10 (10m)	—
	X11 (11m) ~ X15 (15m)	—
	X16 (16m) ~ X20 (20m)	—
	—	—

\* The standard cable is the motor-encoder integrated robot cable.  
 \* See page A-59 for cables for maintenance.

#### Options

Name	Option code	See page	Standard price
Reversed-rotation	NM	→ A-52	—
Shaft adapter	SA	→ A-54	—
Table adapter	TA	→ A-56	—

#### Actuator Specifications

Item	Description
Drive System	Hypoid gear
Positioning repeatability	±0.05 degrees
Homing accuracy	±0.05 degrees
Lost motion	±0.1 degrees
Allowable thrust load	30N
Allowable load moment	3.6 N·m
Weight	0.48kg
Ambient operating temperature, humidity	0 to 40°C, 85% RH or less (Non-condensing)

**399** RCP2-RTCS/RTCSL

For Special Orders  Appendix P.15

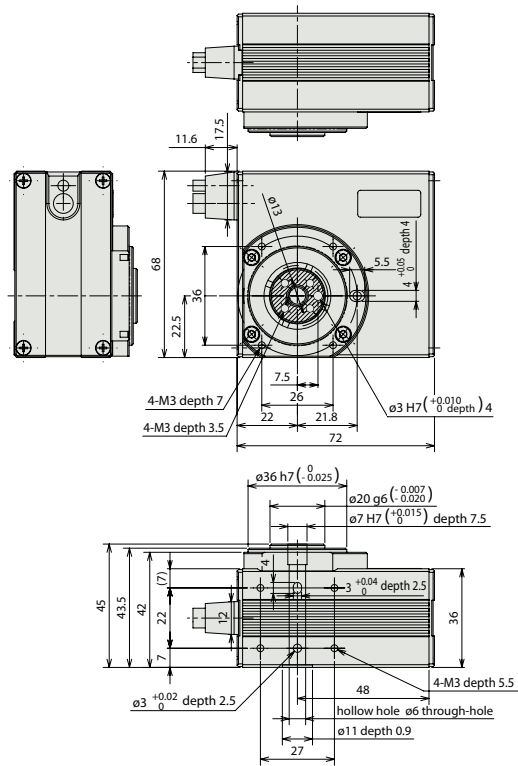

Note:  
\* In the 2D drawing on the left, the shaded area indicates the rotating part.

(\*1) Connect the motor-encoder integrated cable here. See page A-59 for details on cables.

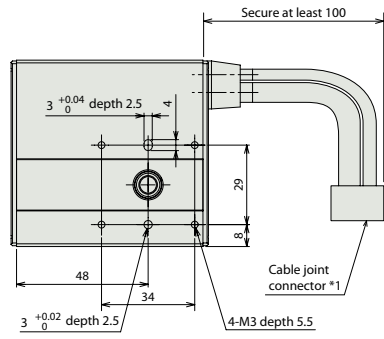

Note:  
The position shown in the top view of the drawing is the home position for both the standard type and reversed rotation type (Option "-NM"). Looking from above, the standard type will rotate counter clockwise during homing, and it then moves clockwise afterward. The reverse rotation type will move clockwise during homing and then moves counter clockwise afterward. Please be aware that the homing direction cannot be changed after shipment. Please refer to the Appendix for the details.

Weight (kg) 0.48

① Applicable Controllers

RCP2 series actuators can be operated with the controllers indicated below. Select the type according to your intended application.

Name	External view	Model number	Features	Maximum number of positioning points	Input power	Power-supply capacity	Standard price	Reference page
Solenoid Valve Type		PMEC-C-20PI-①-2-②	Easy-to-use controller, even for beginners	3 points	AC100V AC200V	Refer to P541	—	→ P537
		PSEP-C-20PI-①-2-0	Simple controller operable with the same signal as a solenoid valve					→ P547
Solenoid valve multi-axis type PIO specification		MSEP-C-①①①-①-2-0	Positioner type based on PIO control, allowing up to 8 axes to be connected	256 points	DC24V	Refer to P572	—	→ P563
Solenoid valve multi-axis type Network specification		MSEP-C-①①①-④④-0-0	Field network-ready positioner type, allowing up to 8 axes to be connected					→ P607
Positioner type High-output specification		PCON-CA-20PI-①-2-0	Equipped with a high-output driver Positioner type based on PIO control	512 points	DC24V	Refer to P618	—	→ P607
Pulse-train type High-output specification		PCON-CA-20PI-PL□-2-0	Equipped with a high-output driver Pulse-train input type	(—)				
Field network type High-output specification		PCON-CA-20PI-④④-0-0	Equipped with a high-output driver Supporting 7 major field networks	768 points				
Pulse Train Input Type (Differential Line Driver)		PCON-PL-20PI-①-2-0	Pulse train input type with differential line driver support	(—)	DC24V	Refer to P628	—	→ P623
Pulse Train Input Type (Open Collector)		PCON-PO-20PI-①-2-0	Pulse train input type with open collector support					
Serial Communication Type		PCON-SE-20PI-N-0-0	Dedicated Serial Communication	64 points	DC24V	Refer to P671	—	→ P665
Program Control Type		PSEL-CS-1-20PI-①-2-0	Programmed operation is possible. Can operate up to 2 axes	1,500 points	DC24V	Refer to P671	—	→ P665

\* This is for the single-axis PSEL. \* ① indicates I/O type (NP/PN). \* ② indicates power supply voltage (1: 100V / 2: 100~240V).  
\* ①① indicates number of axes (1 to 8). \* ④④ indicates field network specification symbol. \* □ indicates N (NPN specification) or P (PNP specification) symbol.

- Slider Type
- Mini
- Standard
- Controllers Integrated
- Rod Type
- Mini
- Standard
- Controllers Integrated
- Table/Arm/Flat Type
- Mini
- Standard
- Gripper/Rotary Type
- Linear Servo Type
- Clean-room Type
- Splash-Proof Type

- Pulse Motor
- Servo Motor (24V)
- Servo Motor (200V)
- Linear Servo Motor



RCP2-RTCS/RTCSL **400**

# RCP2-RTB/RTBL

ROBO Cylinder, Rotary, Medium Vertical Type, Actuator Width 50mm, Pulse Motor

Model Specification Items	<b>RCP2</b>	<b>I</b>	<b>28P</b>					
	Series	Type	Encoder type	Motor type	Deceleration Ratio	Oscillation Angle	Applicable controller	Cable length
	RTB: 330-deg rotation RTBL: Multiple rotation	I: Incremental * The Simple absolute encoder is also considered type "I".	28P: Pulse motor, 28□ size	20: 1/20 deceleration ratio 30: 1/30 deceleration ratio	330: 330-degrees (RTB only) 360: 360-degrees (RTBL only)	P1: PCON-PL/PO/SE PSEL P3: PCON-CA PMEC/PSEP MSEP	N: None P: 1m S: 3m M: 5m X□□: Custom length R□□: Robot cable	NM: Non-motor end SA: Shaft adapter TA: Table adapter

\* See page Pre-47 for details on the model descriptions.



Technical References Appendix P.5

- POINT** Notes on selection
- (1) The output torque decreases as the rotational speed increases. Check the Output Torque graph on the right to see whether the speed required for your desired motion is supported.
  - (2) The allowable moment of inertia of the rotated work piece varies with the rotational speed. Check the Allowable Moment of Inertia graph on the right to see if the moment of inertia required for your desired motion is within the allowable range.
  - (3) The rated acceleration while moving is 0.3G.
  - (4) Please note that the PMEC/PSEP controllers cannot be used when performing infinite rotation with the multiple rotation type.

**Speed vs. Load Capacity**  
Due to the characteristics of the pulse motor, the RCP2 series' load capacity decreases at high speeds. In the table below, check if your desired speed and load capacity are supported.

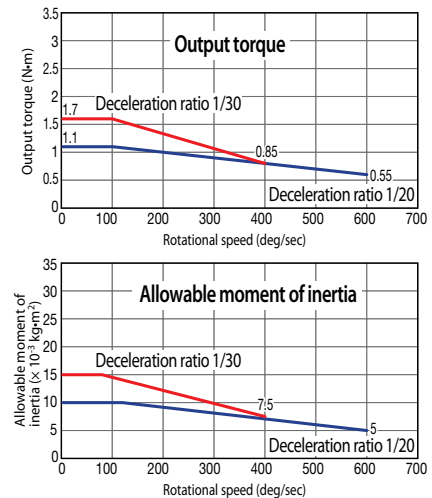

Actuator Specifications				
<b>Leads and Payload</b>				
Model number	Deceleration Ratio	Max. Torque (N · m)	Allowable Movement of Inertia (kg · m <sup>2</sup> )	Oscillation Angle (deg)
RCP2-RTB-I-28P-20-330-①-②-③	1/20	1.1	0.01	330
RCP2-RTB-I-28P-30-330-①-②-③	1/30	1.7	0.015	
RCP2-RTBL-I-28P-20-360-①-②-③	1/20	1.1	0.01	360
RCP2-RTBL-I-28P-30-360-①-②-③	1/30	1.7	0.015	

Code explanation ① Applicable Controller ② Cable Length ③ Options

Deceleration Ratio and Max. Speed	
Stroke	330/360 (deg)
Deceleration ratio	
1/20	600
1/30	400

(Unit: degrees/s)

Stroke		
Type	Oscillation Angle (deg)	Standard price
RTB	330	—
RTBL	360	—

Cable Length		
Type	Cable symbol	Standard Price
Standard	P (1m)	—
	S (3m)	—
	M (5m)	—
Special length	X06 (6m) ~ X10 (10m)	—
	X11 (11m) ~ X15 (15m)	—
	X16 (16m) ~ X20 (20m)	—
Robot Cable	R01 (1m) ~ R03 (3m)	—
	R04 (4m) ~ R05 (5m)	—
	R06 (6m) ~ R10 (10m)	—
	R11 (11m) ~ R15 (15m)	—
	R16 (16m) ~ R20 (20m)	—

\* See page A-59 for cables for maintenance.

Options			
Name	Option code	See page	Standard price
Reversed-rotation	NM	→ A-52	—
Shaft adapter	SA	→ A-54	—
Table adapter	TA	→ A-56	—

Actuator Specifications	
Item	Description
Drive System	Hypoid gear
Positioning repeatability	±0.01 degrees
Homing accuracy	±0.01 degrees (RTB) / ±0.05 (RTBL)
Lost motion	±0.1 degrees
Allowable thrust load	50N
Allowable load moment	3.9 N·m
Weight	0.86kg
Ambient operating temperature, humidity	0 to 40°C, 85% RH or less (Non-condensing)

401 RCP2-RTB/RTBL

Dimensional Drawings

For Special Orders Appendix P.15

Note:  
\* In the 2D drawing below, the shaded area indicates the rotating part.

Note:  
The position shown in the top view of the drawing is the home position for both the standard type and reversed rotation type (Option "NM"). Looking from above, the standard type will rotate counter clockwise during homing, and it then moves clockwise afterward. The reverse rotation type will move clockwise during homing and then moves counter clockwise afterward. Please be aware that the homing direction cannot be changed after shipment. Please refer to the Appendix for the details.

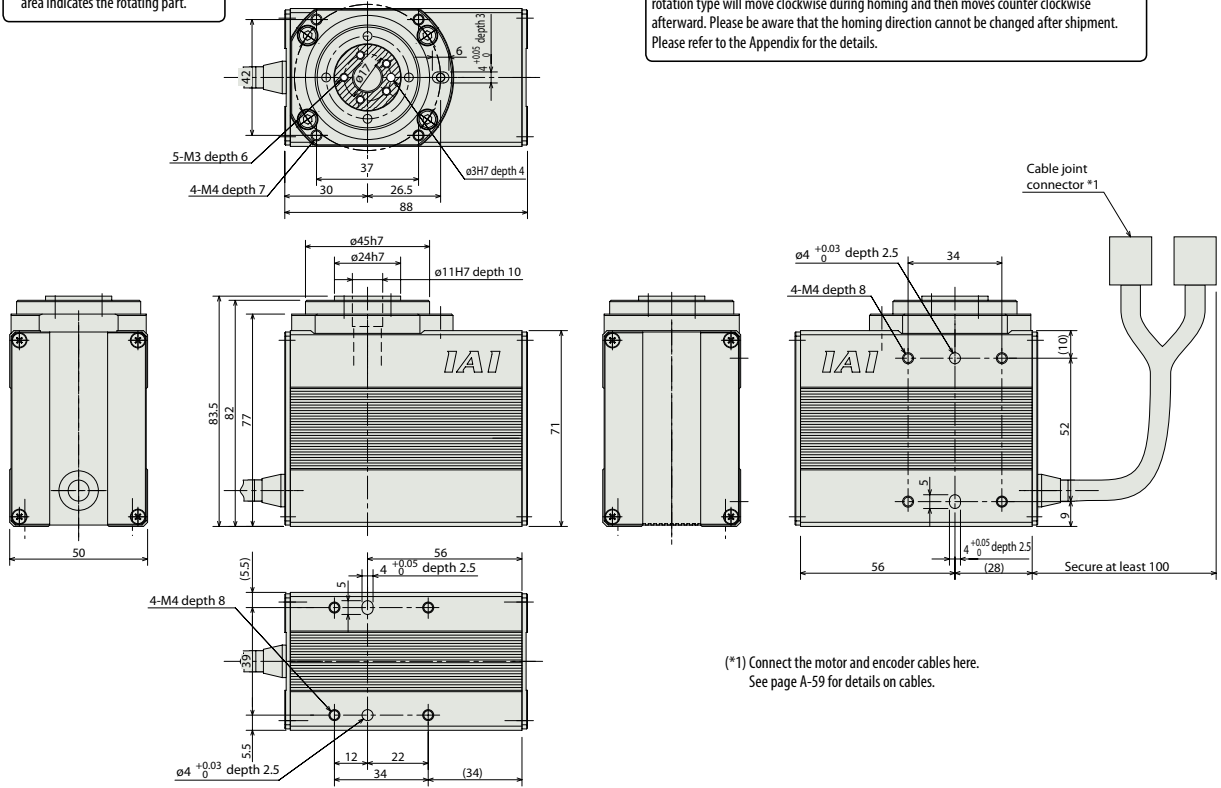

(\*1) Connect the motor and encoder cables here. See page A-59 for details on cables.

\* The bend radius R of the cable is the same as other models.

Weight (kg) 0.86

① Applicable Controllers

RCP2 series actuators can be operated with the controllers indicated below. Select the type according to your intended application.

Name	External view	Model number	Features	Maximum number of positioning points	Input power	Power-supply capacity	Standard price	Reference page
Solenoid Valve Type		PMEC-C-28PI-①-2-②	Easy-to-use controller, even for beginners	3 points	AC100V AC200V	Refer to P541	—	→ P537
		PSEP-C-28PI-①-2-0	Simple controller operable with the same signal as a solenoid valve					
Solenoid valve multi-axis type PIO specification		MSEP-C-③-④-⑤-2-0	Positioner type based on PIO control, allowing up to 8 axes to be connected	256 points	DC24V	Refer to P572	—	→ P563
Solenoid valve multi-axis type Network specification		MSEP-C-③-④-⑤-0-0	Field network-ready positioner type, allowing up to 8 axes to be connected					
Positioner type High-output specification		PCON-CA-28PI-①-2-0	Equipped with a high-output driver Positioner type based on PIO control	512 points	DC24V	Refer to P618	—	→ P607
Pulse-train type High-output specification		PCON-CA-28PI-PL□-2-0	Equipped with a high-output driver Pulse-train input type	(—)				
Field network type High-output specification		PCON-CA-28PI-④-0-0	Equipped with a high-output driver Supporting 7 major field networks	768 points				
Pulse Train Input Type (Differential Line Driver)		PCON-PL-28PI-①-2-0	Pulse train input type with differential line driver support	(—)	DC24V	Refer to P628	—	→ P623
Pulse Train Input Type (Open Collector)		PCON-PO-28PI-①-2-0	Pulse train input type with open collector support					
Serial Communication Type		PCON-SE-28PI-N-0-0	Dedicated Serial Communication	64 points	DC24V	Refer to P671	—	→ P665
Program Control Type		PSEL-CS-1-28PI-①-2-0	Programmed operation is possible. Can operate up to 2 axes	1,500 points	DC24V	Refer to P671	—	→ P665

\* This is for the single-axis PSEL. \* ① indicates I/O type (NP/PN). \* ② indicates power supply voltage (1: 100V / 2: 100~240V). \* ③ indicates number of axes (1 to 8). \* ④ indicates field network specification symbol. \* □ indicates N (NPN specification) or P (PNP specification) symbol.

- Slider Type
- Mini
- Standard
- Controllers Integrated
- Rod Type
- Mini
- Standard
- Controllers Integrated
- Table/Arm/Flat Type
- Mini
- Standard
- Gripper/Rotary Type
- Linear Servo Type
- Clean-room Type
- Splash-Proof Type

- Pulse Motor
- Servo Motor (24V)
- Servo Motor (200V)
- Linear Servo Motor



RCP2-RTB/RTBL **402**

# RCP2-RTC/RTCL

ROBO Cylinder, Rotary, Medium Flat Type, Actuator Width 88mm, Pulse Motor

Model Specification Items	<b>RCP2</b> — <input type="checkbox"/> — <b>I</b> — <b>28P</b> — <input type="checkbox"/> — <input type="checkbox"/> — <input type="checkbox"/> — <input type="checkbox"/> — <input type="checkbox"/>
Series	Type — Encoder type — Motor type — Deceleration Ratio — Oscillation Angle — Applicable controller — Cable length — Options
	RTC: 330-deg rotation RTCL: Multiple rotation I: Incremental * The Simple absolute encoder is also considered type "I". 28P: Pulse motor, 28□ size 20: 1/20 deceleration ratio 30: 1/30 deceleration ratio 330: 330-degrees (RTC only) 360: 360-degrees (RTCL only) P1: PCON-PL/PO/SE PSEL P3: PCON-CA PMEC/PSEP MSEP N: None P: 1m S: 3m M: 5m X□□: Custom length R□□: Robot cable NM: Non-motor end SA: Shaft adapter TA: Table adapter

\* See page Pre-47 for details on the model descriptions.



Technical References Appendix P.5

- POINT**  
Notes on selection
- (1) The output torque decreases as the rotational speed increases. Check the Output Torque graph on the right to see whether the speed required for your desired motion is supported.
  - (2) The allowable moment of inertia of the rotated work piece varies with the rotational speed. Check the Allowable Moment of Inertia graph on the right to see if the moment of inertia required for your desired motion is within the allowable range.
  - (3) The rated acceleration while moving is 0.3G.
  - (4) Please note that the PMEC/PSEP controllers cannot be used when performing infinite rotation with the multiple rotation type.

**Speed vs. Load Capacity**  
Due to the characteristics of the pulse motor, the RCP2 series' load capacity decreases at high speeds. In the table below, check if your desired speed and load capacity are supported.

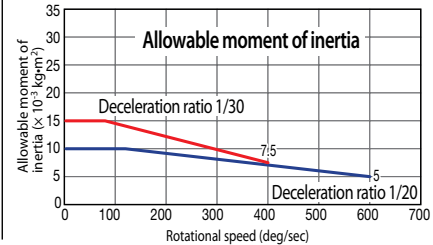
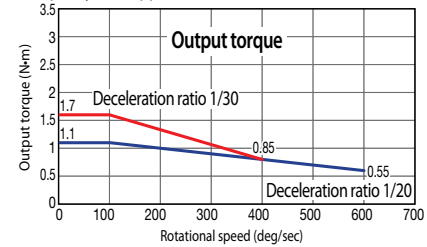

**Actuator Specifications**

**Leads and Payload**

Model number	Deceleration Ratio	Max. Torque (N · m)	Allowable Movement of Inertia (kg · m <sup>2</sup> )	Oscillation Angle (deg)
RCP2-RTC-I-28P-20-330-①-②-③	1/20	1.1	0.01	330
RCP2-RTC-I-28P-30-330-①-②-③	1/30	1.7	0.015	
RCP2-RTCL-I-28P-20-360-①-②-③	1/20	1.1	0.01	360
RCP2-RTCL-I-28P-30-360-①-②-③	1/30	1.7	0.015	

**Deceleration Ratio and Max. Speed**

Deceleration ratio	Stroke	330/360 (deg)
	1/20	600
1/30	400	

(Unit: degrees/s)

Code explanation ① Applicable Controller ② Cable Length ③ Options

**Stroke**

Type	Oscillation Angle (deg)	Standard price
RTC	330	—
RTCL	360	—

**② Cable Length**

Type	Cable symbol	Standard Price
Standard	P (1m)	—
	S (3m)	—
	M (5m)	—
Special length	X06 (6m) ~ X10 (10m)	—
	X11 (11m) ~ X15 (15m)	—
	X16 (16m) ~ X20 (20m)	—
Robot Cable	R01 (1m) ~ R03 (3m)	—
	R04 (4m) ~ R05 (5m)	—
	R06 (6m) ~ R10 (10m)	—
	R11 (11m) ~ R15 (15m)	—
	R16 (16m) ~ R20 (20m)	—
	R20 (20m)	—

\* See page A-59 for cables for maintenance.

**③ Options**

Name	Option code	See page	Standard price
Reversed-rotation	NM	→ A-52	—
Shaft adapter	SA	→ A-54	—
Table adapter	TA	→ A-56	—

**Actuator Specifications**

Item	Description
Drive System	Hypoid gear
Positioning repeatability	±0.01 degrees
Homing accuracy	±0.01 degrees (RTC) / ±0.05 (RTCL)
Lost motion	±0.1 degrees
Allowable thrust load	50N
Allowable load moment	3.9 N·m
Weight	0.92kg
Ambient operating temperature, humidity	0 to 40°C, 85% RH or less (Non-condensing)

**403** RCP2-RTC/RTCL





# RCP2-RTBB/RTBBL

ROBO Cylinder, Rotary, Large Vertical Type, Actuator Width 76mm, Pulse Motor

Model Specification Items	<b>RCP2</b> — <input type="checkbox"/> — <b>I</b> — <b>35P</b> — <input type="checkbox"/> — <input type="checkbox"/> — <input type="checkbox"/> — <input type="checkbox"/> — <input type="checkbox"/>
	Series — Type — Encoder type — Motor type — Deceleration Ratio — Oscillation Angle — Applicable controller — Cable length — Options
	RTBB:330-deg rotation RTBBL:Multiple rotation
	I: Incremental * The Simple absolute encoder is also considered type "I".
	35P: Pulse motor, 35□ size
	20: 1/20 deceleration ratio 30: 1/30 deceleration ratio
	330: 330-degrees (RTBB only) 360: 360-degrees (RTBBL only)
	P1: PCON-PL/PO/SE PSEL P3: PCON-CA PMEC/PSEP MSEP
	N: None P: 1m S: 3m M: 5m X□□: Custom length R□□: Robot cable
	NM: Non-motor end SA: Shaft adapter TA: Table adapter

\* See page Pre-47 for details on the model descriptions.



Technical References Appendix P.5

- POINT** Notes on selection
- The output torque decreases as the rotational speed increases. Check the Output Torque graph on the right to see whether the speed required for your desired motion is supported.
  - The allowable moment of inertia of the rotated work piece varies with the rotational speed. Check the Allowable Moment of Inertia graph on the right to see if the moment of inertia required for your desired motion is within the allowable range.
  - The rated acceleration while moving is 0.3G.
  - Please note that the PMEC/PSEP controllers cannot be used when performing infinite rotation with the multiple rotation type.

**Speed vs. Load Capacity**  
Due to the characteristics of the pulse motor, the RCP2 series' load capacity decreases at high speeds. In the table below, check if your desired speed and load capacity are supported.

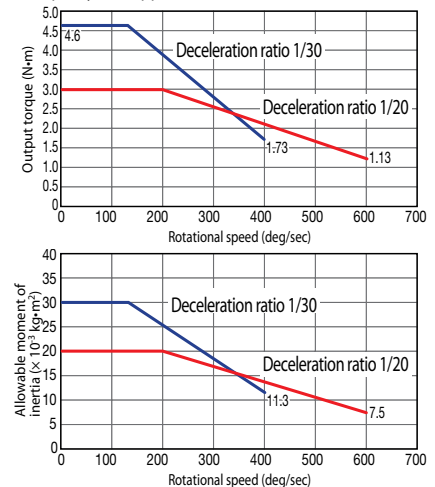

Actuator Specifications					Deceleration Ratio and Max. Speed	
Leads and Payload					Stroke	330/360 (deg)
Model number	Deceleration Ratio	Max. Torque (N · m)	Allowable Movement of Inertia (kg · m <sup>2</sup> )	Oscillation Angle (deg)	Deceleration ratio	
RCP2-RTBB-I-35P-20-330-①-②-③	1/20	3.0	0.02	330	1/20	600
RCP2-RTBB-I-35P-30-330-①-②-③	1/30	4.6	0.03		1/30	400
RCP2-RTBBL-I-35P-20-360-①-②-③	1/20	3.0	0.02	360	(Unit: degrees/s)	
RCP2-RTBBL-I-35P-30-360-①-②-③	1/30	4.6	0.03			

Code explanation ① Applicable Controller ② Cable Length ③ Options

Stroke		
Type	Oscillation Angle (deg)	Standard price
RTBB	330	—
RTBBL	360	—

Cable Length			
Type	Cable symbol	Standard Price	
Standard	P (1m)	—	
	S (3m)	—	
	M (5m)	—	
Special length	X06 (6m) ~ X10 (10m)	—	
	X11 (11m) ~ X15 (15m)	—	
	X16 (16m) ~ X20 (20m)	—	
	R01 (1m) ~ R03 (3m)	—	
Robot Cable	R04 (4m) ~ R05 (5m)	—	
	R06 (6m) ~ R10 (10m)	—	
	R11 (11m) ~ R15 (15m)	—	
	R16 (16m) ~ R20 (20m)	—	

\* See page A-59 for cables for maintenance.

Options			
Name	Option code	See page	Standard price
Reversed-rotation	NM	→ A-52	—
Shaft adapter	SA	→ A-54	—
Table adapter	TA	→ A-56	—

Actuator Specifications	
Item	Description
Drive System	Hypoid gear
Positioning repeatability	±0.01 degrees
Homing accuracy	±0.01 degrees (RTBB) / ±0.03 (RTBBL)
Lost motion	±0.1 degrees
Allowable thrust load	200N
Allowable load moment	17.7 N·m
Weight	2.3kg
Ambient operating temperature, humidity	0 to 40°C, 85% RH or less (Non-condensing)

## 405 RCP2-RTBB/RTBBL

For Special Orders  Appendix P.15

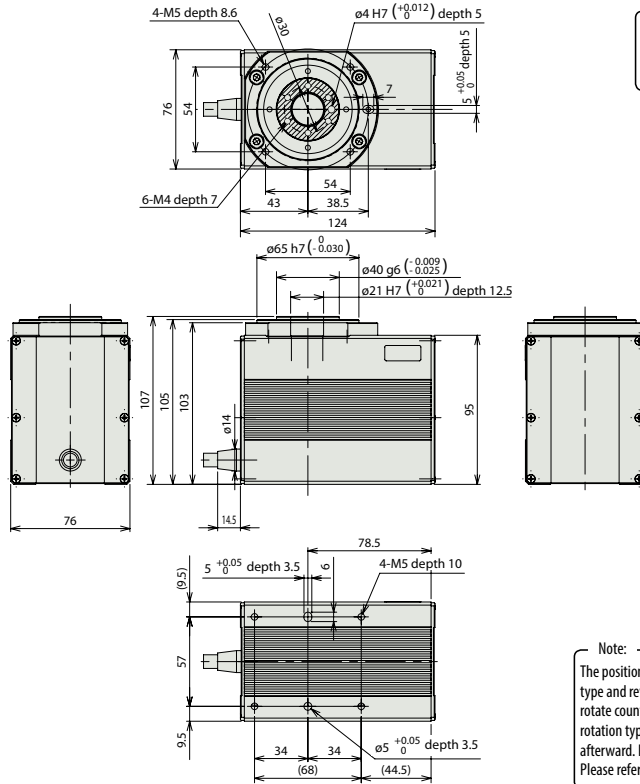

Note:  
\* In the 2D drawing on the left, the shaded area indicates the rotating part.

(\*1) Connect the motor and encoder cables here. See page A-59 for details on cables.

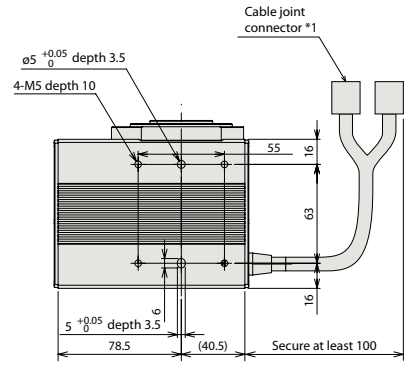

Note:  
The position shown in the top view of the drawing is the home position for both the standard type and reversed rotation type (Option "-NM"). Looking from above, the standard type will rotate counter clockwise during homing, and it then moves clockwise afterward. The reverse rotation type will move clockwise during homing and then moves counter clockwise afterward. Please be aware that the homing direction cannot be changed after shipment. Please refer to the Appendix for the details.

Weight (kg) 2.3

① Applicable Controllers

RCP2 series actuators can be operated with the controllers indicated below. Select the type according to your intended application.

Name	External view	Model number	Features	Maximum number of positioning points	Input power	Power-supply capacity	Standard price	Reference page
Solenoid Valve Type		PMEC-C-35PI-①-2-②	Easy-to-use controller, even for beginners	3 points	AC100V AC200V	Refer to P541	—	→ P537
		PSEP-C-35PI-①-2-0	Simple controller operable with the same signal as a solenoid valve			Refer to P555	—	→ P547
Solenoid valve multi-axis type PIO specification		MSEP-C-④-④-①-2-0	Positioner type based on PIO control, allowing up to 8 axes to be connected	256 points	DC24V	Refer to P572	—	→ P563
Solenoid valve multi-axis type Network specification		MSEP-C-④-④-④-0-0	Field network-ready positioner type, allowing up to 8 axes to be connected			Refer to P618	—	→ P607
Positioner type High-output specification		PCON-CA-35PI-①-2-0	Equipped with a high-output driver Positioner type based on PIO control	512 points	DC24V	Refer to P618	—	→ P607
Pulse-train type High-output specification		PCON-CA-35PI-PL□-2-0	Equipped with a high-output driver Pulse-train input type	(—)		Refer to P628	—	
Field network type High-output specification		PCON-CA-35PI-④-0-0	Equipped with a high-output driver Supporting 7 major field networks	768 points		Refer to P628	—	
Pulse Train Input Type (Differential Line Driver)		PCON-PL-35PI-①-2-0	Pulse train input type with differential line driver support	(—)	DC24V	Refer to P628	—	→ P623
Pulse Train Input Type (Open Collector)		PCON-PO-35PI-①-2-0	Pulse train input type with open collector support			Refer to P671	—	
Serial Communication Type		PCON-SE-35PI-N-0-0	Dedicated Serial Communication	64 points	DC24V	Refer to P671	—	→ P665
Program Control Type		PSEL-CS-1-35PI-①-2-0	Programmed operation is possible. Can operate up to 2 axes	1,500 points	DC24V	Refer to P671	—	→ P665

\* This is for the single-axis PSEL. \* ① indicates I/O type (NP/PN). \* ② indicates power supply voltage (1: 100V / 2: 100~240V).  
\* ④ indicates number of axes (1 to 8). \* ④ indicates field network specification symbol. \* □ indicates N (NPN specification) or P (PNP specification) symbol.

- Slider Type
- Mini
- Standard
- Controllers Integrated
- Rod Type
- Mini
- Standard
- Controllers Integrated
- Table/Arm/Flat Type
- Mini
- Standard
- Gripper/Rotary Type
- Linear Servo Type
- Clean-room Type
- Splash-Proof Type

- Pulse Motor
- Servo Motor (24V)
- Servo Motor (200V)
- Linear Servo Motor



RCP2-RTBB/RTBBL

406



# RCP2-RTCB/RTCBL

ROBO Cylinder, Rotary, Large Flat Type, Actuator Width 124mm, Pulse Motor

Model Specification Items	<b>RCP2</b>	<b>I</b>	<b>35P</b>					
	Series	Type	Encoder type	Motor type	Deceleration Ratio	Oscillation Angle	Applicable controller	Cable length
	RTCB: 330-deg rotation RTCBL: Multiple rotation	I: Incremental * The Simple absolute encoder is also considered type "I".	35P: Pulse motor, 35□ size	20: 1/20 deceleration ratio 30: 1/30 deceleration ratio	330: 330-degrees (RTCB only) 360: 360-degrees (RTCBL only)	P1: PCON-PL/PO/SE PSEL P3: PCON-CA PMEC/PSEP MSEP	N: None P: 1m S: 3m M: 5m X□□: Custom length R□□: Robot cable	NM: Non-motor end SA: Shaft adapter TA: Table adapter

\* See page Pre-47 for details on the model descriptions.



Technical References Appendix P.5

- POINT** Notes on selection
- The output torque decreases as the rotational speed increases. Check the Output Torque graph on the right to see whether the speed required for your desired motion is supported.
  - The allowable moment of inertia of the rotated work piece varies with the rotational speed. Check the Allowable Moment of Inertia graph on the right to see if the moment of inertia required for your desired motion is within the allowable range.
  - The rated acceleration while moving is 0.3G.
  - Please note that the PMEC/PSEP controllers cannot be used when performing infinite rotation with the multiple rotation type.

### Speed vs. Load Capacity

Due to the characteristics of the pulse motor, the RCP2 series' load capacity decreases at high speeds. In the table below, check if your desired speed and load capacity are supported.

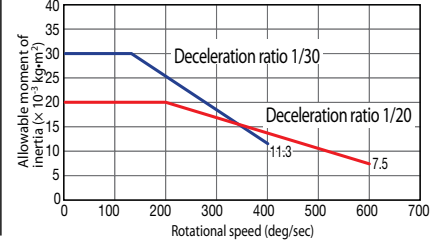
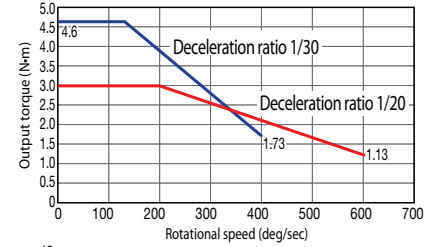

### Actuator Specifications

#### Leads and Payload

Model number	Deceleration Ratio	Max. Torque (N · m)	Allowable Movement of Inertia (kg · m <sup>2</sup> )	Oscillation Angle (deg)
RCP2-RTCB-I-35P-20-330-①-②-③	1/20	3.0	0.02	330
RCP2-RTCB-I-35P-30-330-①-②-③	1/30	4.6	0.03	
RCP2-RTCBL-I-35P-20-360-①-②-③	1/20	3.0	0.02	360
RCP2-RTCBL-I-35P-30-360-①-②-③	1/30	4.6	0.03	

#### Deceleration Ratio and Max. Speed

Deceleration ratio	Stroke	330/360 (deg)
	1/20	600
1/30	400	400

(Unit: degrees/s)

Code explanation ① Applicable Controller ② Cable Length ③ Options

#### Stroke

Type	Oscillation Angle (deg)	Standard price
RTCB	330	—
RTCBL	360	—

#### Cable Length

Type	Cable symbol	Standard Price
Standard	P (1m)	—
	S (3m)	—
	M (5m)	—
Special length	X06 (6m) ~ X10 (10m)	—
	X11 (11m) ~ X15 (15m)	—
	X16 (16m) ~ X20 (20m)	—
Robot Cable	R01 (1m) ~ R03 (3m)	—
	R04 (4m) ~ R05 (5m)	—
	R06 (6m) ~ R10 (10m)	—
	R11 (11m) ~ R15 (15m)	—
	R16 (16m) ~ R20 (20m)	—
	R16 (16m) ~ R20 (20m)	—

\* See page A-59 for cables for maintenance.

#### Options

Name	Option code	See page	Standard price
Reversed-rotation	NM	→ A-52	—
Shaft adapter	SA	→ A-54	—
Table adapter	TA	→ A-56	—

#### Actuator Specifications

Item	Description
Drive System	Hypoid gear
Positioning repeatability	±0.01 degrees
Homing accuracy	±0.01 degrees (RTCB) / ±0.03 (RTCBL)
Lost motion	±0.1 degrees
Allowable thrust load	200N
Allowable load moment	17.7 N·m
Weight	2.2kg
Ambient operating temperature, humidity	0 to 40°C, 85% RH or less (Non-condensing)

# 407

RCP2-RTCB/RTCBL

Sold & Serviced By:



Toll Free Phone (877) SERV098  
Toll Free Fax (877) SERV099  
www.electromate.com  
sales@electromate.com

- Slider Type
- Mini
- Standard
- Controllers Integrated
- Rod Type
- Mini
- Standard
- Controllers Integrated
- Table/ Arm/ Flat Type
- Mini
- Standard
- Gripper/ Rotary Type
- Linear Servo Type
- Clean-room Type
- Splash-Proof Type
- Pulse Motor
- Servo Motor (24V)
- Servo Motor (200V)
- Linear Servo Motor



# RCS2-RTC8L

ROBO Cylinder, Hollow Rotary, Small Standard Type, Actuator Width 85mm, 200V servo Motor

# RCS2-RTC8HL

ROBO Cylinder, Hollow Rotary, Small High Output Type, Actuator Width 85mm, 200V servo Motor

Model Specification Items	<b>RCS2</b>	—	□	—	□	—	□	—	□	—	<b>360</b>	—	<b>T2</b>	—	□	—	□
	Series	Type	Encoder type	Motor type	Deceleration Ratio	Oscillation Angle	Applicable controller	Cable length	Options								
	RTC8L: Small standard type	I: Incremental	A: Absolute	12: 12W Servo motor 20: 20W Servo motor	15: 1/15 deceleration ratio 24: 1/24 deceleration ratio	360: 360-degrees (multiple rotation)	T2: SCON MSCON SSEL XSEL-P/Q XSEL-R/S	N: None P: 1m S: 3m M: 5m X□□: Custom length R□□: Robot cable	See Options below.								

\* See page Pre-47 for details on the model descriptions.



\*CE compliance is optional.

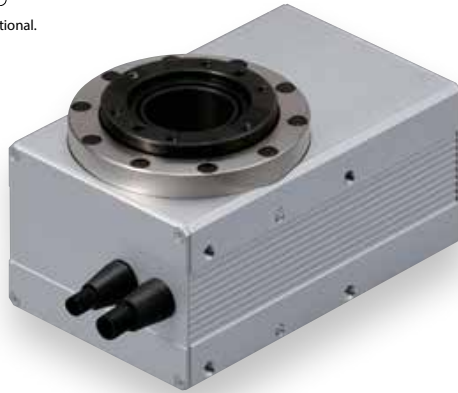

Technical References Appendix P.5

**POINT** Notes on selection

- The rated and maximum acceleration is 0.3G.
- Positioning mode can move between 0 to 9,999.99 deg (0 to 7,670.99 deg with reduction ratio of 1/24). Index rotation mode can move from 0 to 359.99 deg. (Once the actuator moves beyond 359.99 deg, it resets to 0 without having to rotate back to home.)
- Actuator may vibrate as it moves if the speed is lower than 100 deg/s. Please drive the unit at or above 100mm/s.

### Actuator Specifications

#### Leads and Payload

Model number	Motor Output (N)	Deceleration Ratio	Max. Torque (N · m)	Allowable Movement of Inertia (kg · m <sup>2</sup> )	Oscillation Angle (deg)
RCS2-RTC8L-①-12-24-360-T2-②-③	12	1/24	0.55	0.011	360 (*)
RCS2-RTC8HL-①-20-15-360-T2-②-③	20	1/15	0.53	0.01	
RCS2-RTC8HL-①-20-24-360-T2②-③		1/24	0.85	0.017	

#### Deceleration Ratio and Max. Speed

Deceleration ratio	Stroke	360 (deg)
1/15		1200
1/24		750

(Unit: degrees/s)

Code explanation ① Encoder type ② Cable length ③ Options

\* Refer to "POINT Notes on Selection" above.

#### ① Encoder Type

Type	Standard price	
	① Encoder Type	
	Incremental	Absolute
RTC8L	—	—
RTC8HL	—	—

#### ② Cable Length

Type	Cable symbol	Standard Price
Standard	P (1m)	—
	S (3m)	—
	M (5m)	—
Special length	X06 (6m) ~ X10 (10m)	—
	X11 (11m) ~ X15 (15m)	—
	X16 (16m) ~ X20 (20m)	—
	R01 (1m) ~ R03 (3m)	—
Robot Cable	R04 (4m) ~ R05 (5m)	—
	R06 (6m) ~ R10 (10m)	—
	R11 (11m) ~ R15 (15m)	—
	R16 (16m) ~ R20 (20m)	—

\* See page A-59 for cables for maintenance.

#### ③ Options

Name	Option code	See page	Standard price
Brake	B	→ A-42	—
CE compliance	CE	→ A-42	—
Limit switch (standard feature)	L	→ A-51	—
Reversed-rotation	NM	→ A-52	—

#### Actuator Specifications

Item	Description
Drive System	Timing belt drive system + hypoid gear
Positioning repeatability	±0.005 degrees
Backlash	±0.05 degrees or less
Allowable thrust load	400N
Allowable load moment	5 N·m
Brake retention torque	0.42 N·m
Weight	2.3kg
Ambient operating temperature, humidity	0 to 40°C, 85% RH or less (Non-condensing)

# 409

RCS2-RTC8L/RTC8HL

Dimensional Drawings

For Special Orders  Appendix P.15

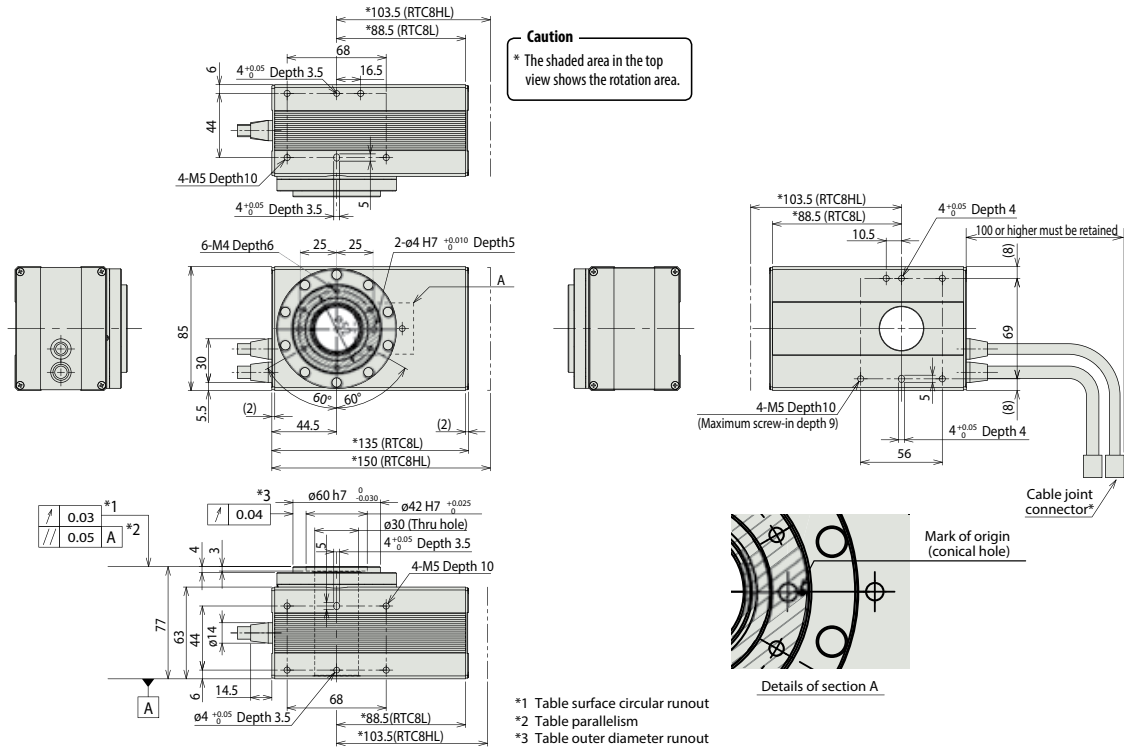

\* Connect the motor and encoder cables here.  
(See page A-59 for details on cables.)



**Note:**  
The position in the detail A drawing above is the homing location for both standard type/reversed rotation type (Option "-NM"). Looking from the above, the standard type will rotate counter clockwise during homing, and it moves clockwise afterward. Reverse rotation type will move clockwise during homing and moves counter clockwise afterward.

Applicable Controllers

RCS2-series actuators can be operated with the following controllers. Select an appropriate controller type according to your application.

Name	External view	Model number	Features	Maximum number of positioning points	Input power	Power supply capacity	Standard price	Reference page
Positioner mode		SCON-CA-12①-NP-2-②③ SCON-CA-20①-NP-2-②③	Up to 512 positioning points are supported.	512 points	Single-phase 100VAC Single-phase 200VAC 3-phase 200VAC (XSEL-P/Q/R/S ONLY)	106 VA max. *Power supply capacity will vary depending on the controller, so please refer to the instruction manual for details.	—	→ P643
Solenoid valve mode			Actuators can be operated through the same control used for solenoid valves.	7 points				
Field network type			Movement by numerical specification is supported.	768 points				
Pulse-train input control type			Dedicated pulse-train input type	(—)				
Positioner multi-axis, network type		MSCON-C-1-12①-④-0-②③ MSCON-C-1-20①-④-0-②③	Up to 6 axes can be operated. Movement by numerical specification is supported.	256 points	—	—	→ P655	
Program control type, 1 to 2 axes	SSEL-CS-1-12①-NP-2-②③ SSEL-CS-1-20①-NP-2-②③	Program operation is supported. Up to 2 axes can be operated.	20,000 points	→ P685				
Program control type, 1 to 8 axes	XSEL-④-1-12①-N1-EEE-2-④⑤ XSEL-④-1-20①-N1-EEE-2-④⑤	Program operation is supported. Up to 8 axes can be operated.	Varies depending on the number of axes connected					→ P695

\* This is for the single-axis MSCON, SSEL, and XSEL.

\*① indicates the power-supply voltage type (1: 100V / 2: Single-phase 200V).

\*④⑤ indicates the power-supply voltage type (1: 100 V / 2: Single-phase 200V / 3: Three-phase 200V).

\*① indicates the encoder type (I: Incremental / A: Absolute).

\*②③ indicates the XSEL type (J / K / P / Q / R / S).

\*④ indicates field network specification symbol.

IAI

RCS2-RTC8L/RTC8HL

410

Sold & Serviced By:



Toll Free Phone (877) SERV098

Toll Free Fax (877) SERV099

www.electromate.com

sales@electromate.com

Slider Type

Mini

Standard

Controllers Integrated

Rod Type

Mini

Standard

Controllers Integrated

Table/ Arm/ Flat Type

Mini

Standard

Gripper/ Rotary Type

Linear Servo Type

Clean-room Type

Splash-Proof Type

Pulse Motor

Servo Motor (24V)

Servo Motor (200V)

Linear Servo Motor

# RCS2-RTC10L

Robo Cylinder, Hollow Rotary, Medium Type, Actuator Width 99mm, 200V Servo Motor

Model Specification Items	<b>RCS2</b> — <b>RTC10L</b> — <input type="checkbox"/> — <b>60</b> — <input type="checkbox"/> — <b>360</b> — <b>T2</b> — <input type="checkbox"/> — <input type="checkbox"/>
	Series — Type — Encoder type — Motor type — Deceleration Ratio — Oscillation Angle — Applicable controller — Cable length — Options
	RTC10L: Medium type I: Incremental A: Absolute 60: 60W Servo motor 15: 1/15 deceleration ratio 24: 1/24 deceleration ratio 360: 360-degrees (multiple rotation) T2: SCON MSCON SSEL XSEL-P/Q XSEL-R/S N: None P: 1m S: 3m M: 5m X <input type="checkbox"/> : Custom length R <input type="checkbox"/> : Robot cable See Options below.

\* See page Pre-47 for details on the model descriptions.



\*CE compliance is optional.



Technical References Appendix P.5

- POINT**  
Notes on selection
- (1) The rated and maximum acceleration is 0.3G.
  - (2) Positioning mode can move between 0 to 9,999.99 deg (0 to 7,670.99 deg with reduction ratio of 1/24). Index rotation mode can move from 0 to 359.99 deg. (Once the actuator moves beyond 359.99 deg, it resets to 0 without having to rotate back to home.)
  - (3) Actuator may vibrate as it moves if the speed is lower than 100 deg/s. Please drive the unit at or above 100mm/s.

### Actuator Specifications

#### Leads and Payload

Model number	Motor Output (W)	Deceleration Ratio	Max. Torque (N · m)	Allowable Movement of Inertia (kg · m <sup>2</sup> )	Oscillation Angle (deg)
RCS2-RTC10L-①-60-15-360-T2-②-③	60	1/15	1.7	0.033	360 (*)
RCS2-RTC10L-①-60-24-360-T2-②-③		1/24	2.8	0.054	

#### Deceleration Ratio and Max. Speed

Deceleration ratio	Stroke	360 (deg)
	1/15	1200
1/24	750	

Code explanation ① Encoder type ② Cable length ③ Options

\* Refer to "POINT Notes on Selection" above.

(Unit: degrees/s)

#### ① Encoder Type

Type	Standard price	
	① Encoder Type	
	Incremental	Absolute
<b>RTC10L</b>	—	—

#### ② Cable Length

Type	Cable symbol	Standard Price
Standard	<b>P</b> (1m)	—
	<b>S</b> (3m)	—
	<b>M</b> (5m)	—
Special length	<b>X06</b> (6m) ~ <b>X10</b> (10m)	—
	<b>X11</b> (11m) ~ <b>X15</b> (15m)	—
	<b>X16</b> (16m) ~ <b>X20</b> (20m)	—
	<b>R01</b> (1m) ~ <b>R03</b> (3m)	—
Robot Cable	<b>R04</b> (4m) ~ <b>R05</b> (5m)	—
	<b>R06</b> (6m) ~ <b>R10</b> (10m)	—
	<b>R11</b> (11m) ~ <b>R15</b> (15m)	—
	<b>R16</b> (16m) ~ <b>R20</b> (20m)	—

\* See page A-59 for cables for maintenance.

#### ③ Options

Name	Option code	See page	Standard price
Brake	<b>B</b>	→ A-42	—
CE-compliant specification	<b>CE</b>	→ A-42	—
Limit switch (standard)	<b>L</b>	→ A-51	—
Reversed-rotation	<b>NM</b>	→ A-52	—

#### Actuator Specifications

Item	Description
Drive System	Timing belt drive system + hypoid gear
Positioning repeatability	±0.005 degrees
Backlash	±0.05 degrees or less
Allowable thrust load	600N
Allowable load moment	10 N·m
Brake retention torque	0.45 N·m
Weight	3.5kg
Ambient operating temperature, humidity	0 to 40°C, 85% RH or less (Non-condensing)

# 411

RCS2-RTC10L

Dimensional Drawings

For Special Orders  Appendix P.15

\* Connect the motor and encoder cables here.  
(See page A-59 for details on cables.)

Dimensions of mounting holes on the side are bilaterally symmetric.

**Caution**

\* The shaded area in the top view shows the rotation area.

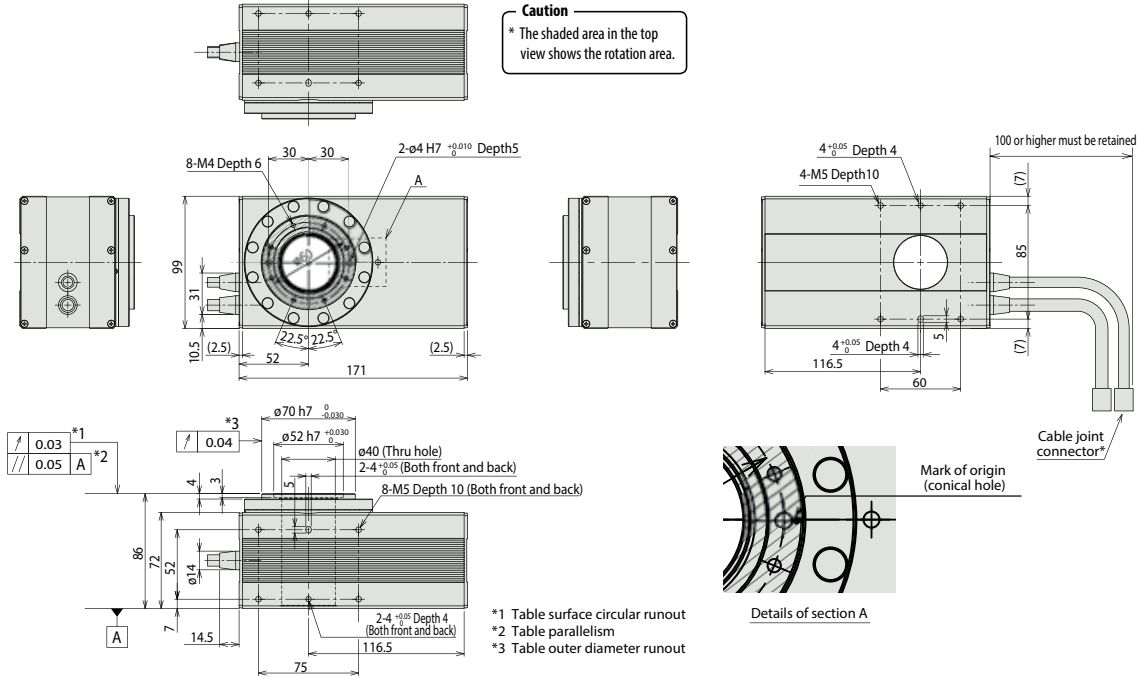





- \*1 Table surface circular runout
- \*2 Table parallelism
- \*3 Table outer diameter runout

Note:  
The position in the detail A drawing above is the homing location for both standard type/reversed rotation type (Option "NM"). Looking from the above, the standard type will rotate counter clockwise during homing, and it moves clockwise afterward. Reverse rotation type will move clockwise during homing and moves counter clockwise afterward.

Applicable Controllers

RCS2-series actuators can be operated with the following controllers. Select an appropriate controller type according to your application.

Name	External view	Model number	Features	Maximum number of positioning points	Input power	Power supply capacity	Standard price	Reference page	
Positioner mode		SCON-CA-60①-NP-2-②	Up to 512 positioning points are supported.	512 points	Single-phase 100VAC Single-phase 200VAC 3-phase 200VAC (XSEL-P/Q/R/S ONLY)	218 VA max. *Power supply capacity will vary depending on the controller, so please refer to the instruction manual for details.	—	→ P643	
Solenoid valve mode			Actuators can be operated through the same control used for solenoid valves.	7 points					
Field network type			Movement by numerical specification is supported.	768 points					
Pulse-train input control type			Dedicated pulse-train input type	(—)					
Positioner multi-axis, network type		MSCON-C-1-60①-④-0-③	Up to 6 axes can be operated. Movement by numerical specification is supported.	256 points	—	—	→ P655		
Program control type, 1 to 2 axes		SSEL-CS-1-60①-NP-2-②	Program operation is supported. Up to 2 axes can be operated.	20,000 points				—	→ P685
Program control type, 1 to 8 axes		XSEL-③-1-60①-N1-EEE-2-④	Program operation is supported. Up to 8 axes can be operated.	Varies depending on the number of axes connected					

\* This is for the single-axis MSCON, SSEL, and XSEL.

\* ① indicates the power-supply voltage type (1: 100V / 2: Single-phase 200V).

\* ② indicates the power-supply voltage type (1: 100V / 2: Single-phase 200V / 3: Three-phase 200V).

\* ① indicates the encoder type (I: Incremental / A: Absolute).

\* ③ indicates the XSEL type (J / K / P / Q / R / S).

\* ④ indicates field network specification symbol.

IAI

RCS2-RTC10L

412

Sold & Serviced By:



Toll Free Phone (877) SERV098

Toll Free Fax (877) SERV099

www.electromate.com

sales@electromate.com

Slider Type

Mini

Standard

Controllers Integrated

Rod Type

Mini

Standard

Controllers Integrated

Table/ Arm/ Flat Type

Mini

Standard

Gripper/ Rotary Type

Linear Servo Type

Clean-room Type

Splash-Proof Type

Pulse Motor

Servo Motor (24V)

Servo Motor (200V)

Linear Servo Motor



# RCS2-RTC12L

Robo Cylinder, Hollow Rotary, Large Type, Actuator Width 123mm, 200V Servo Motor

Model Specification Items	<b>RCS2</b> — <b>RTC12L</b> — <input type="checkbox"/> — <b>150</b> — <input type="checkbox"/> — <b>360</b> — <b>T2</b> — <input type="checkbox"/> — <input type="checkbox"/>
	Series — Type — Encoder type — Motor type — Deceleration Ratio — Oscillation Angle — Applicable controller — Cable length — Options
	RTC12L: Large type I: Incremental A: Absolute 150: 150W Servo motor 18: 1/18 deceleration ratio 30: 1/30 deceleration ratio 360: 360-degrees (multiple rotation) T2: SCON MSCON SSEL XSEL-P/Q XSEL-R/S N: None P: 1m S: 3m M: 5m X <input type="checkbox"/> : Custom length R <input type="checkbox"/> : Robot cable See Options below.

\* See page Pre-47 for details on the model descriptions.



\*CE compliance is optional.



Technical References Appendix P.5

- POINT**  
Notes on selection
- (1) The rated and maximum acceleration is 0.3G.
  - (2) Positioning mode can move between 0 to 9,999.99 deg (0 to 6,140.99 deg with reduction ratio of 1/30). Index rotation mode can move from 0 to 359.99 deg. (Once the actuator moves beyond 359.99 deg, it resets to 0 without having to rotate back to home.)
  - (3) Actuator may vibrate as it moves if the speed is lower than 100 deg/s. Please drive the unit at or above 100mm/s.

### Actuator Specifications

#### Leads and Payload

Model number	Motor Output (W)	Deceleration Ratio	Max. Torque (N · m)	Allowable Movement of Inertia (kg · m <sup>2</sup> )	Oscillation Angle (deg)
RCS2-RTC12L-①-150-18-360-T2-②-③	150	1/18	5.2	0.1	360 (*)
RCS2-RTC12L-①-150-30-360-T2-②-③		1/30	8.6	0.17	

#### Deceleration Ratio and Max. Speed

Deceleration ratio	Stroke	360 (deg)
	1/18	800
1/30	600	

Code explanation ① Encoder type ② Cable length ③ Options

\* Refer to "POINT Notes on Selection" above.

(Unit: degrees/s)

#### ① Encoder Type

Type	Standard price	
	① Encoder Type	
	Incremental	Absolute
<b>RTC12L</b>	—	—

#### ② Cable Length

Type	Cable symbol	Standard Price
Standard	<b>P</b> (1m)	—
	<b>S</b> (3m)	—
	<b>M</b> (5m)	—
Special length	<b>X06</b> (6m) ~ <b>X10</b> (10m)	—
	<b>X11</b> (11m) ~ <b>X15</b> (15m)	—
	<b>X16</b> (16m) ~ <b>X20</b> (20m)	—
	<b>R01</b> (1m) ~ <b>R03</b> (3m)	—
Robot Cable	<b>R04</b> (4m) ~ <b>R05</b> (5m)	—
	<b>R06</b> (6m) ~ <b>R10</b> (10m)	—
	<b>R11</b> (11m) ~ <b>R15</b> (15m)	—
	<b>R16</b> (16m) ~ <b>R20</b> (20m)	—

\* See page A-59 for cables for maintenance.

#### ③ Options

Name	Option code	See page	Standard price
Brake	<b>B</b>	→ A-42	—
CE-compliant specification	<b>CE</b>	→ A-42	—
Limit switch (standard)	<b>L</b>	→ A-51	—
Reversed-rotation	<b>NM</b>	→ A-52	—

#### Actuator Specifications

Item	Description
Drive System	Timing belt drive system + hypoid gear
Positioning repeatability	±0.005 degrees
Backlash	±0.05 degrees or less
Allowable thrust load	800N
Allowable load moment	25 N·m
Brake retention torque	1.0 N·m
Weight	6.5kg
Ambient operating temperature, humidity	0 to 40°C, 85% RH or less (Non-condensing)

# 413

RCS2-RTC12L

Dimensional Drawings

For Special Orders Appendix P.15

\* Connect the motor and encoder cables here.  
(See page A-59 for details on cables.)

Dimensions of mounting holes on the side are bilaterally symmetric.

Caution

\* The shaded area in the top view shows the rotation area.

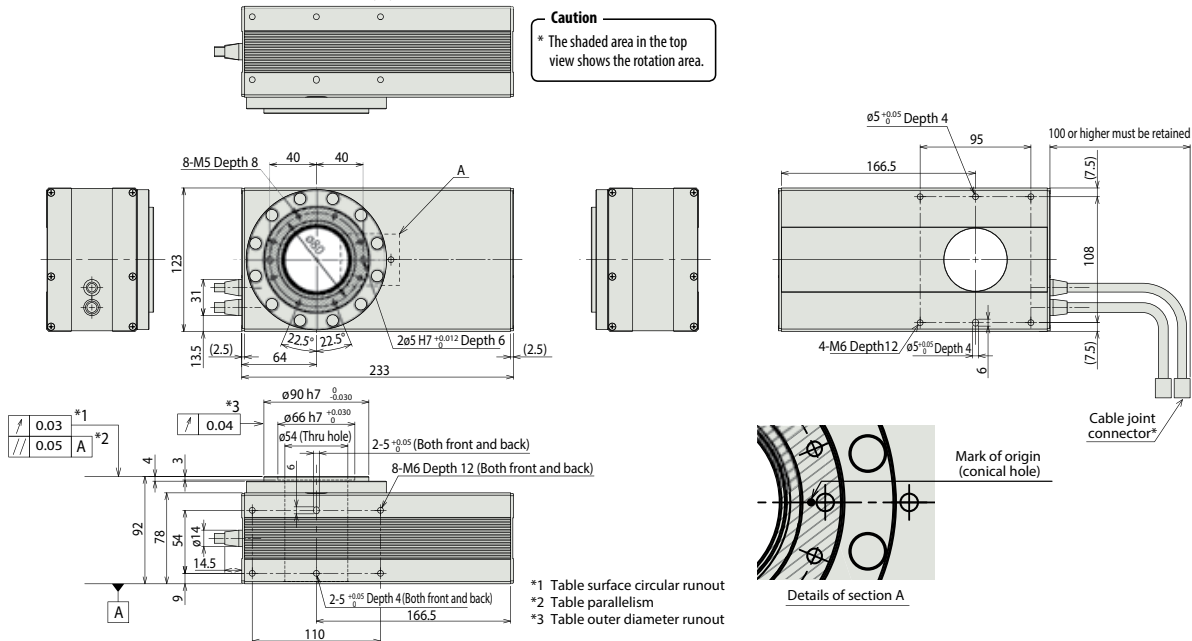

- \*1 Table surface circular runout
- \*2 Table parallelism
- \*3 Table outer diameter runout

Note:  
The position in the detail A drawing above is the homing location for both standard type/reversed rotation type (Option "-NM"). Looking from the above, the standard type will rotate counter clockwise during homing, and it moves clockwise afterward. Reverse rotation type will move clockwise during homing and moves counter clockwise afterward.

Applicable Controllers

RCS2-series actuators can be operated with the following controllers. Select an appropriate controller type according to your application.

Name	External view	Model number	Features	Maximum number of positioning points	Input power	Power supply capacity	Standard price	Reference page		
Positioner mode		SCON-CA-150①-NP-2-①	Up to 512 positioning points are supported.	512 points	Single-phase 100VAC Single-phase 200VAC 3-phase 200VAC (XSEL-P/Q/R/S ONLY)	408 VA max. *Power supply capacity will vary depending on the controller, so please refer to the instruction manual for details.	—	→ P643		
Solenoid valve mode			Actuators can be operated through the same control used for solenoid valves.	7 points						
Field network type			Movement by numerical specification is supported.	768 points						
Pulse-train input control type			Dedicated pulse-train input type	(—)						
Positioner multi-axis, network type		MCON-C-1-150①-④-0-①	Up to 6 axes can be operated. Movement by numerical specification is supported.	256 points			—	→ P655		
Program control type, 1 to 2 axes		SSEL-CS-1-150①-NP-2-①	Program operation is supported. Up to 2 axes can be operated.	20,000 points					—	→ P685
Program control type, 1 to 8 axes		XSEL-①-1-150①-N1-EEE-2-④	Program operation is supported. Up to 8 axes can be operated.	Varies depending on the number of axes connected						

\* This is for the single-axis MCON, SSEL, and XSEL.  
 \* ① indicates the power-supply voltage type (1: 100V / 2: Single-phase 200V).  
 \* ② indicates the power-supply voltage type (1: 100V / 2: Single-phase 200V).  
 \* ④ indicates the XSEL type (J / K / P / Q / R / S).  
 \* ④ indicates field network specification symbol.  
 \* ① indicates the encoder type (I: Incremental / A: Absolute).  
 \* ② indicates the XSEL type (J / K / P / Q / R / S).  
 \* ④ indicates field network specification symbol.

- Slider Type
- Mini
- Standard
- Controllers Integrated
- Rod Type
- Mini
- Standard
- Controllers Integrated
- Table/Arm/Flat Type
- Mini
- Standard
- Gripper/Rotary Type
- Linear Servo Type
- Clean-room Type
- Splash-Proof Type

- Pulse Motor
- Servo Motor (24V)
- Servo Motor (200V)
- Linear Servo Motor

# RCS2-RT6

Robo Cylinder, Rotary, Straight Motor Model, Actuator Width 64mm, 200V Servo Motor

Model Specification Items	<b>RCS2</b> — <b>RT6</b> — <b>I</b> — <b>60</b> — <b>18</b> — <b>300</b> — <input type="checkbox"/> — <input type="checkbox"/> — <input type="checkbox"/> — <b>L</b>
	Series — Type — Encoder type — Motor type — Deceleration Ratio — Oscillation Angle — Applicable controller — Cable length — Options
	I: Incremental    60: 60W Servo motor    18: 1/18    300: 300-degrees    T1: XSEL-J/K    T2: SCON    SSEL    XSEL-P/Q    XSEL-R/S    N: None    P: 1m    S: 3m    M: 5m    X <input type="checkbox"/> : Custom length    R <input type="checkbox"/> : Robot cable    See Options below.

\* See page Pre-47 for details on the model descriptions.



\*CE compliance is optional.



Technical References Appendix P.5

**POINT** Notes on selection

(1) The thrust load is the mechanical strength of the output axis at rest. When selecting, take into account the load moment and the load inertia.

(2) The rated acceleration while moving is 0.3G.

Actuator Specifications						Deceleration Ratio and Max. Speed	
Lead and Payload						Oscillation Angle (deg)	300 (deg)
Model number	Motor Output (W)	Deceleration Ratio	Rated Torque (N·m)	Allowable Moment of Inertia (kg·m <sup>2</sup> )	Deceleration ratio		
RCS2-RT6-I-60-18-300-①-②-③-L	60	1/18	2.4	2.5 x 10 <sup>-2</sup> or less	300	1/18	500

Code explanation ① Applicable Controller ② Cable Length ③ Options

Stroke	
Oscillation Angle (deg)	Standard price
300	—

Cable Length		
Type	Cable symbol	Standard Price
Standard	P (1m)	—
	S (3m)	—
	M (5m)	—
Special length	X06 (6m) ~ X10 (10m)	—
	X11 (11m) ~ X15 (15m)	—
	X16 (16m) ~ X20 (20m)	—
Robot Cable	R01 (1m) ~ R03 (3m)	—
	R04 (4m) ~ R05 (5m)	—
	R06 (6m) ~ R10 (10m)	—
	R11 (11m) ~ R15 (15m)	—
	R16 (16m) ~ R20 (20m)	—

\* See page A-59 for cables for maintenance.

Options			
Name	Option code	See page	Standard price
CE compliance	CE	→ A-42	—
Limit switch (standard)	L	→ A-51	—

Actuator Specifications	
Item	Description
Drive System	Ball speed reducer
Positioning repeatability	±0.02 degrees
Lost motion	0.1degrees or less
Base	Material: Aluminum, white alumite treated
Allowable load moment	Ma: 6.8 N·m or less
Thrust load	100N or less
Ambient operating temperature, humidity	0 to 40°C, 85% RH or less (Non-condensing)

# 415

RCS2-RT6

For Special Orders  Appendix P.15

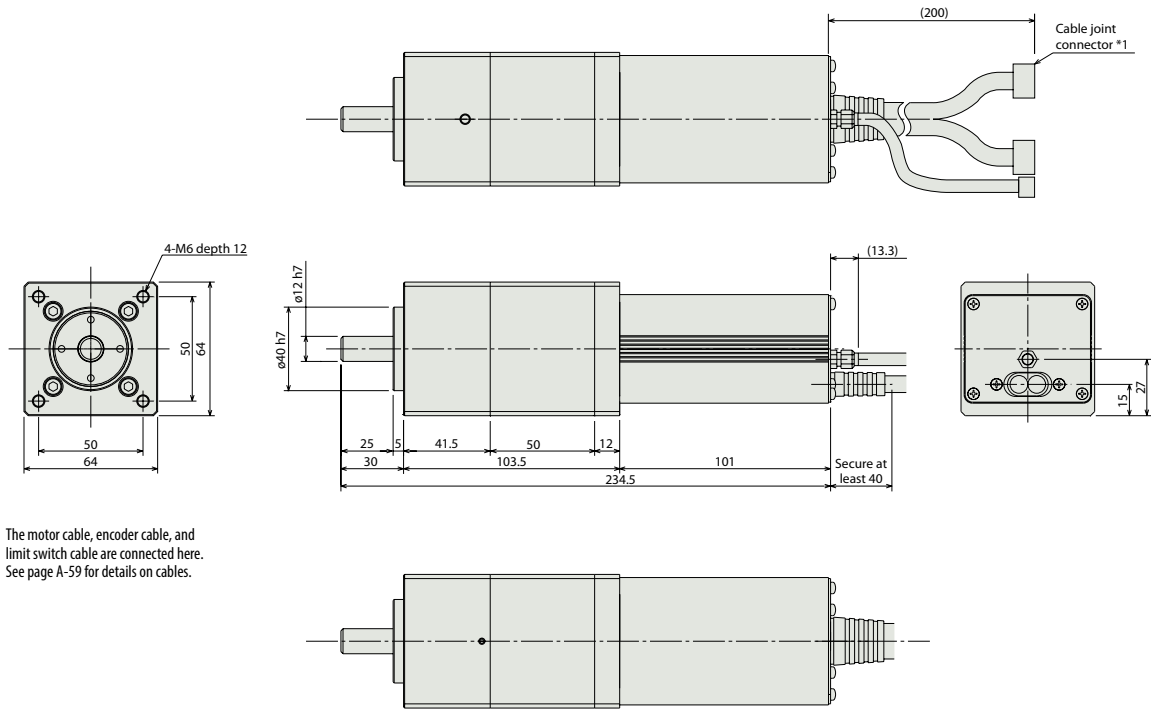





(\*1) The motor cable, encoder cable, and limit switch cable are connected here. See page A-59 for details on cables.

Weight (kg) 1.9

① Applicable Controllers

RCS2-series actuators can be operated with the following controllers. Select an appropriate controller type according to your application.

Name	External view	Model number	Features	Maximum number of positioning points	Input power	Power supply capacity	Standard price	Reference page		
Positioner mode		SCON-CA-60I-NP-2-①	Up to 512 positioning points are supported.	512 points	Single-phase 100VAC Single-phase 200VAC 3-phase 200VAC (XSEL-P/Q/R/S ONLY)	218 VA max. *Power supply capacity will vary depending on the controller, so please refer to the instruction manual for details.	—	→ P643		
Solenoid valve mode			Actuators can be operated through the same control used for solenoid valves.	7 points						
Field network type			Movement by numerical specification is supported.	768 points						
Pulse-train input control type			Dedicated pulse-train input type	(-)						
Positioner multi-axis, network type		MSCON-C-1-60-②-0-①	Up to 6 axes can be operated. Movement by numerical specification is supported.	256 points			—	→ P655		
Program control type, 1 to 2 axes		SSEL-CS-1-60I-NP-2-①	Program operation is supported. Up to 2 axes can be operated.	20,000 points					—	→ P685
Program control type, 1 to 8 axes		XSEL-①-1-60I-N1-EEE-2-③	Program operation is supported. Up to 8 axes can be operated.	Varies depending on the number of axes connected					—	→ P695

\* This is for the single-axis MSCON, SSEL, and XSEL.  
 \* ① indicates the XSEL type (J / K / P / Q / R / S).  
 \* ② indicates field network specification symbol.

\* ① indicates the power-supply voltage type (1: 100 V / 2: Single-phase 200 V).  
 \* ② indicates the power-supply voltage type (1: 100 V / 2: Single-phase 200 V / 3: Three-phase 200 V).

- Slider Type
- Mini
- Standard
- Controllers Integrated
- Rod Type
- Mini
- Standard
- Controllers Integrated
- Table/ Arm/ Flat Type
- Mini
- Standard
- Gripper/ Rotary Type
- Linear Servo Type
- Clean-room Type
- Splash-Proof Type
- Pulse Motor
- Servo Motor (24V)
- Servo Motor (200V)
- Linear Servo Motor