

# RCS2-SRA7BD

ROBO Cylinder Rod Type 75mm Width 200V Servo Motor  
Short-Length Type

■ Configuration: **RCS2** — **SRA7BD** —  —  —  —  —  —  —  —  —

Series — Type — Encoder — Motor — Lead — Stroke — Compatible Controllers — Cable Length — Option

I : Incremental  
 60 : 60W Servo Motor  
 100 : 100W Servo Motor  
 150 : 150W Servo Motor

16 : 16mm  
 8 : 8mm  
 4 : 4mm

50 : 50mm  
 300 : 300mm (50mm pitch increments)

T1 : XSEL-J/K  
 T2 : SCON  
 SSEL  
 XSEL-P/Q

N : None  
 P : 1m  
 S : 3m  
 M : 5m  
 X  : Custom  
 R  : Robot cable

See Options below

\* See page Pre-35 for an explanation of the naming convention.



Technical References P. A-5

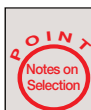

- (1) When operated at the rated acceleration, the maximum load capacity is the load capacity at the rated acceleration.
- (2) When operated at the maximum acceleration, the maximum load capacity is the load capacity at the maximum acceleration.
- (3) If positioning repeatability and/or lost motion is required, the rotation of the rod must be restricted. In this case, select a model with a guide, or add a separate guide.
- (4) The standard model may exhibit vibration of the rod at long strokes. If this is an issue, select a model with a guide, or add a separate guide.

## Actuator Specifications

### Lead and Load Capacity

Model	Motor Output (W)	Lead (mm)	Rated Acceleration (G)	Load Capacity at Rated Acceleration		Maximum Acceleration (G)	Load Capacity at Max. Acceleration		Rated Thrust (N)	Stroke (mm)
				Horizontal (kg)	Vertical (kg)		Horizontal (kg)	Vertical (kg)		
RCS2-SRA7BD-I-60-16-①-②-③-④	60	16	0.25	5	2	0.35	2.5	1	63	
RCS2-SRA7BD-I-60-8-①-②-③-④		8	0.15	10	5	0.25	5	2.5		
RCS2-SRA7BD-I-60-4-①-②-③-④		4	0.05	20	10	0.15	10	5		
RCS2-SRA7BD-I-100-16-①-②-③-④	100	16	0.3	10	3.5	0.4	5	1.5	103	
RCS2-SRA7BD-I-100-8-①-②-③-④		8	0.2	22	9	0.3	10	4.5		
RCS2-SRA7BD-I-100-4-①-②-③-④		4	0.1	40	19.5	0.2	20	9		
RCS2-SRA7BD-I-150-16-①-②-③-④	150	16	0.3	15	6.5	0.4	7.5	3	157	
RCS2-SRA7BD-I-150-8-①-②-③-④		8	0.2	35	14.5	0.3	17.5	7		
RCS2-SRA7BD-I-150-4-①-②-③-④		4	0.1	55	22.5	0.2	27.5	11		

Legend ① Stroke ② Compatible controller ③ Cable length ④ Options

### Stroke and Maximum Speed

Stroke Lead	50 ~ 300 (50mm increments)	
	Stroke	50 ~ 300 (50mm increments)
16	800	
8	400	
4	200	

(Unit: mm/s)

### ① Stroke List

Stroke (mm)	Standard Price		
	Motor power output		
	60W	100W	150W
50	-	-	-
100	-	-	-
150	-	-	-
200	-	-	-
250	-	-	-
300	-	-	-

### ③ Cable List

Type	Cable Symbol	Standard Price
Standard	P (1m)	-
	S (3m)	-
	M (5m)	-
Special Lengths	X06 (6m) ~ X10 (10m)	-
	X11 (11m) ~ X15 (15m)	-
	X16 (16m) ~ X20 (20m)	-
Robot Cable	R01 (1m) ~ R03 (3m)	-
	R04 (4m) ~ R05 (5m)	-
	R06 (6m) ~ R10 (10m)	-
	R11 (11m) ~ R15 (15m)	-
	R16 (16m) ~ R20 (20m)	-

\* See page A-39 for cables for maintenance.

### ④ Option List

Name	Option Code	See Page	Standard Price
Connector cable exit direction	A1 ~ A3	→ A-25	-
Brake	B	→ A-25	-
Flange	FL	→ A-27	-
Foot bracket	FT	→ A-29	-
Extended rod tip	RE	→ A-35	-

### Actuator Specifications

Item	Description
Drive System	Ball screw ø12mm C10 grade
Positioning Repeatability	±0.02mm
Lost Motion	0.1mm or less
Base	Material: Aluminum (white alumite treated)
Rod Diameter	ø35mm
Non-rotating accuracy of rod	-
Ambient Operating Temp./Humidity	0 ~ 40°C, 85% RH or less (non-condensing)

# 241

RCS2-SRA7BD

Dimensions

For Special Orders P. A-9

\* The SRA7BD is not available in reversed-home configuration, due to its construction.

- \*1. The motor-encoder cable is connected here. See page A-39 for details on cables.
- \*2. When homing, the rod moves to the mechanical end position; therefore, please watch for any interference with the surrounding objects.  
ST: Stroke  
SE: Stroke end  
ME: Mechanical end
- \*3. The orientation of the bolt will vary depending on the product.

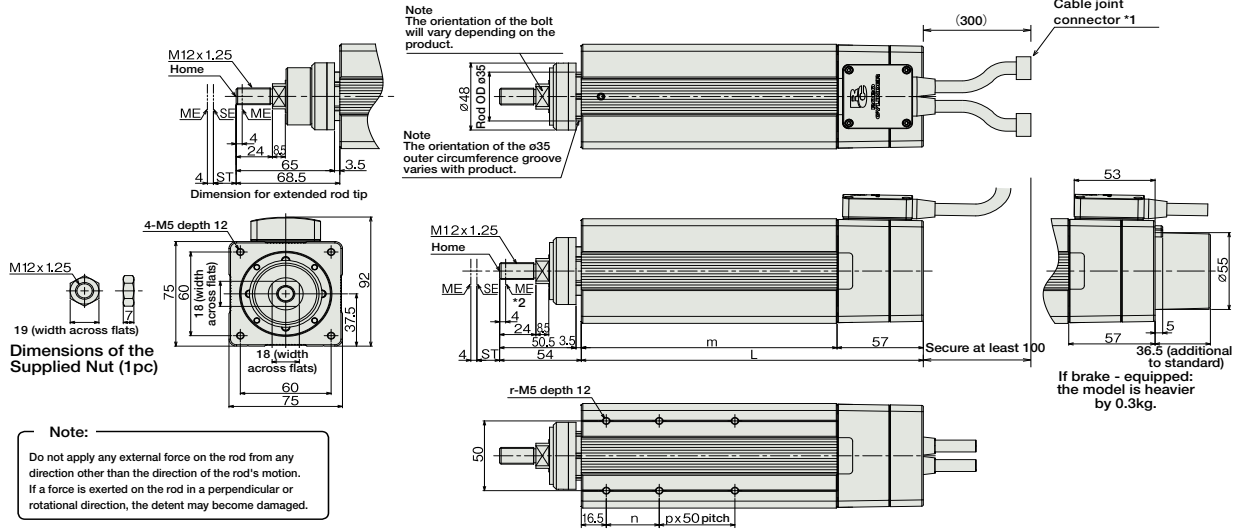

**Note:**  
Do not apply any external force on the rod from any direction other than the direction of the rod's motion. If a force is exerted on the rod in a perpendicular or rotational direction, the detent may become damaged.

**Note:**  
A slit is provided in the side of the actuator body to prevent pauses due to forward/backward operation. Please make a separate request for a dustproof/splash-proof model.

Dimensions/Weight by Stroke

Stroke	Stroke						
	50	100	150	200	250	300	
L	60W	126	176	226	276	326	376
	100W	133	176	226	276	326	376
	150W	145	176	226	276	326	376
m	60W	69	119	169	219	269	319
	100W	76	119	169	219	269	319
	150W	88	119	169	219	269	319
n	25	35	35	35	35	35	
p	0	0	1	2	3	4	
r	4	4	6	8	10	12	
Weight (kg)	60W	2.4	2.9	3.5	4.1	4.6	5.2
	100W	2.6	3.1	3.7	4.2	4.8	5.4
	150W	2.9	3.3	3.9	4.4	5	5.6

② Compatible Controllers

The RCS2 series actuators can operate with the controllers below. Select the controller according to your usage.

Name	External View	Model	Description	Max. Positioning Points	Input Voltage	Power Supply Capacity	Standard Price	See Page
Positioner Mode		SCON-C-①I-NP-2-②	Positioning is possible for up to 512 points	512 points	Single-Phase AC 100V Single-Phase AC 200V Three-phase AC 200V (XSEL-P/Q only)	360VA max.  * When operating a 150W single-axis model	-	→ P547
Solenoid Valve Mode			Operable with same controls as solenoid valve.	7 points				
Serial Communication Type			Dedicated to serial communication	64 points				
Pulse Train Input Control Type			Dedicated to Pulse Train Input	(-)				
Program Control 1-2 Axes Type		SSEL-C-1-①I-NP-2-②	Programmed operation is possible. Operation is possible on up to 2 axes	20000 points			-	→ P577
Program Control 1-6 Axes Type		XSEL-③-1-①I-NI-EEE-2-④	Programmed operation is possible. Operation is possible on up to 6 axes	20000 points			-	→ P587

**Note:** The SRA7BD type actuator cannot be connected to the 5th and 6th axis of the XSEL-P/Q controller.

- \* For SSEL and XSEL, only applicable to the single-axis model.
- \* ① is a placeholder for the motor output (W) (60, 100, 150).
- \* ② is a placeholder for the power supply voltage (1: 100V, 2: single-phase 200V).
- \* ③ is a placeholder for the XSEL type name ("J", "K", "P", or "Q").
- \* ④ is a placeholder for the power supply voltage (1: 100V, 2: single-phase 200V, or 3: three-phase 200V).



RCS2-SRA7BD **242**

- Slider Type
- Mini
- Standard
- Controllers Integrated
- Rod Type
- Mini
- Standard
- Controllers Integrated
- Table/Arm/Flat Type
- Mini
- Standard
- Gripper/Rotary Type
- Linear Servo Type
- Cleanroom Type
- Splash Proof
- Controllers
- PMEC/AMEC
- PSEP/ASEP
- ROBO NET
- ERC2
- PCON
- ACON
- SCON
- PSEL
- ASEL
- SSEL
- XSEL
- Pulse Motor
- Servo Motor (24V)
- Servo Motor (200V)
- Linear Servo Motor