

# RCS2-RA5R

ROBO Cylinder Rod Type 55mm Width 200V Servo Motor Side-Mounted Motor

■ Configuration: **RCS2** — **RA5R** —  — **60** —  —  —  —  —

Series — Type — Encoder — Motor — Lead — Stroke — Compatible Controllers — Cable Length — Option

I : Incremental  
A : Absolute

60 : 60W Servo Motor

16 : 16mm  
8 : 8mm  
4 : 4mm

50 : 50mm  
300 : 300mm (50mm pitch increments)

T1 : XSEL-J/K  
T2 : SCON  
SSEL  
XSEL-P/Q

N : None  
P : 1m  
S : 3m  
M : 5m  
X  : Custom  
R  : Robot cable

See Options below  
\* Be sure to specify which side the motor is to be mounted (ML/MR).

\* See page Pre-35 for an explanation of the naming convention.

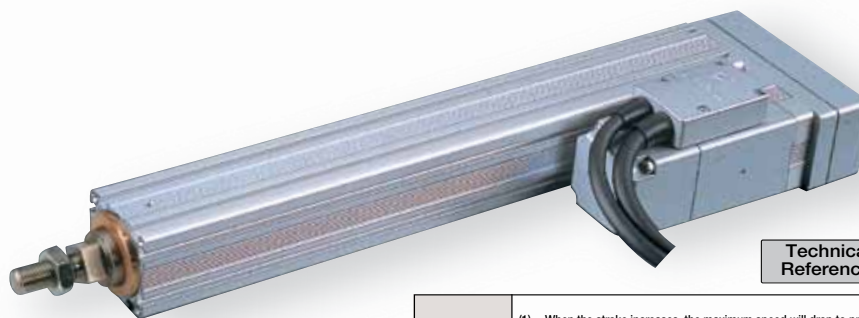

Technical References P. A-5

- POINT**  
Notes on Selection
- (1) When the stroke increases, the maximum speed will drop to prevent the ball screw from reaching the critical rotational speed. Use the actuator specification table below to check the maximum speed at the stroke you desire.
  - (2) The load capacity is based on operation at an acceleration of 0.3G (0.2G for the 4mm-lead model). This is the upper limit of the acceleration.
  - (3) The values for the horizontal load capacity assume the use of an external guide, so that there is no external force from any direction other than the forward/backward direction of the rod.

**Actuator Specifications**

■ Lead and Load Capacity

Model	Motor Output (W)	Lead (mm)	Max. Load Capacity		Rated Thrust (N)	Stroke (mm)
			Horizontal (kg)	Vertical (kg)		
RCS2-RA5R-①-60-16-②-③-④-⑤	60	16	12.0	2.0	63.8	50 ~ 300 (50mm increments)
RCS2-RA5R-①-60-8-②-③-④-⑤		8	25.0	5.0	127.5	
RCS2-RA5R-①-60-4-②-③-④-⑤		4	50.0	11.5	255.1	

Legend: ① Encoder ② Stroke ③ Compatible controller ④ Cable length ⑤ Options

■ Stroke and Maximum Speed

Lead	Stroke		300 (mm)
	50 ~ 250 (50mm increments)	300 (mm)	
16	800	755	
8	400	377	
4	200	188	

(Unit: mm/s)

**Encoder & Stroke List**

② Stroke (mm)	Standard Price	
	① Encoder	
	Incremental	Absolute
50	-	-
100	-	-
150	-	-
200	-	-
250	-	-
300	-	-

**④ Cable List**

Type	Cable Symbol	Standard Price
Standard	P (1m)	-
	S (3m)	-
	M (5m)	-
Special Lengths	X06 (6m) ~ X10 (10m)	-
	X11 (11m) ~ X15 (15m)	-
	X16 (16m) ~ X20 (20m)	-
Robot Cable	R01 (1m) ~ R03 (3m)	-
	R04 (4m) ~ R05 (5m)	-
	R06 (6m) ~ R10 (10m)	-
	R11 (11m) ~ R15 (15m)	-
	R16 (16m) ~ R20 (20m)	-

\* See page A-39 for cables for maintenance.

**⑤ Option List**

Name	Option Code	See Page	Standard Price
Connector cable exit direction	A2	→ A-25	-
Brake	B	→ A-25	-
Flange	FL	→ A-27	-
Foot bracket	FT	→ A-29	-
Left-Mounted Motor (Standard)	ML	→ A-33	-
Right-Mounted Motor	MR	→ A-33	-

**Actuator Specifications**

Item	Description
Drive System	Ball screw $\phi$ 12mm C10 grade
Positioning Repeatability	$\pm$ 0.02mm
Lost Motion	0.1mm or less
Base	Material: Aluminum (white alumite treated)
Rod Diameter	$\phi$ 30mm
Non-rotating accuracy of rod	$\pm$ 0.7 deg
Ambient Operating Temp./Humidity	0 ~ 40°C, 85% RH or less (non-condensing)

# 245

RCS2-RA5R

Dimensions

For Special Orders P. A-9

\* The RA5R is not available in reversed-home configuration, due to its construction.

1. The motor-encoder cable is connected here. See page A-39 for details on cables.
2. When homing, the rod moves to the ME; therefore, please watch for any interference with the surrounding objects.  
ME: Mechanical end SE: Stroke end
3. The orientation of the bolt will vary depending on the product.

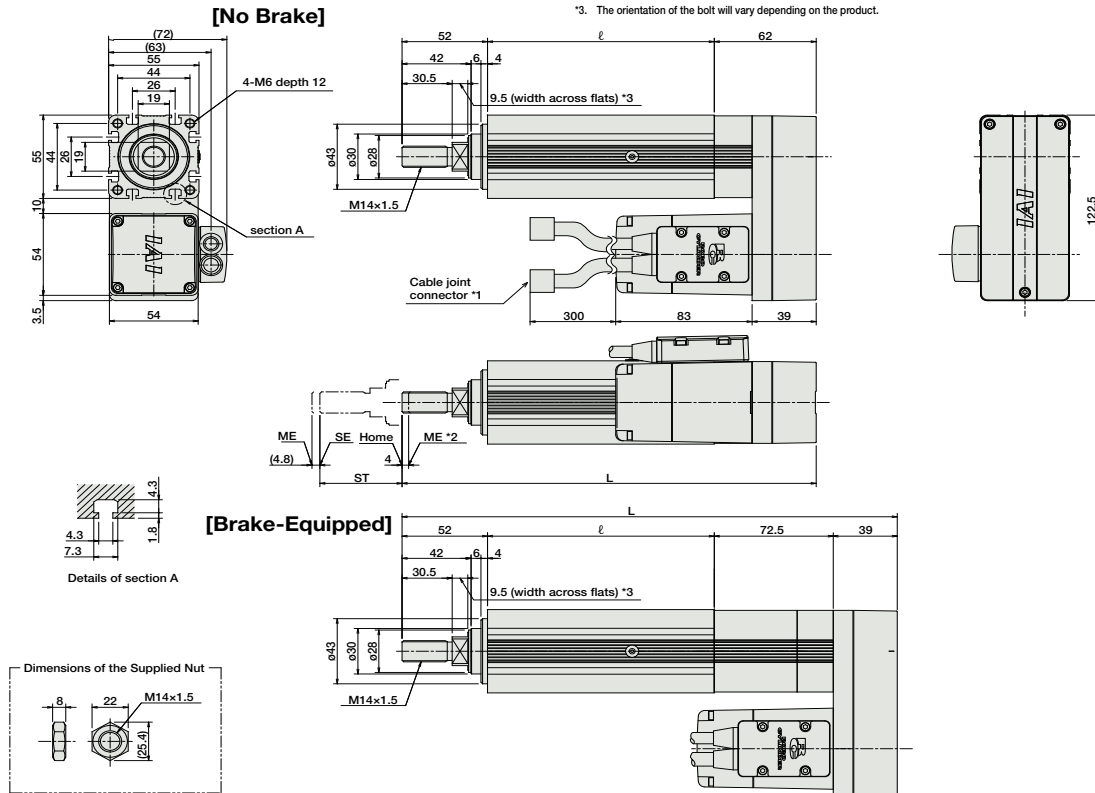

■ Dimensions/Weight by Stroke

RCS2-RA5R (without brake)

Stroke	50	100	150	200	250	300
L	252	302	352	402	452	502
ℓ	138	188	238	288	338	388
Weight (kg)	2.3	2.6	2.9	3.2	3.5	3.8

RCS2-RA5R (with brake)

Stroke	50	100	150	200	250	300
L	301.5	351.5	401.5	451.5	501.5	551.5
ℓ	138	188	238	288	338	388
Weight (kg)	2.6	2.9	3.2	3.5	3.8	4.1

③ Compatible Controllers

The RCS2 series actuators can operate with the controllers below. Select the controller according to your usage.

Name	External View	Model	Description	Max. Positioning Points	Input Voltage	Power Supply Capacity	Standard Price	See Page
Positioner Mode		SCON-C-60①-NP-2②	Positioning is possible for up to 512 points	512 points	Single-Phase AC 100V Single-Phase AC 200V Three-phase AC 200V (XSEL-P/Q only)	360VA max.  * When operating a 150W single-axis model	-	→ P547
Solenoid Valve Mode			Operable with same controls as solenoid valve.	7 points				
Serial Communication Type			Dedicated to serial communication	64 points				
Pulse Train Input Control Type			Dedicated to Pulse Train Input	(-)				
Program Control 1-2 Axes Type		SSEL-C-1-60①-NP-2②	Programmed operation is possible Operation is possible on up to 2 axes	20000 points			-	→ P577
Program Control 1-6 Axes Type		XSEL-③-1-60①-N1-EEE-2④	Programmed operation is possible Operation is possible on up to 6 axes	20000 points			-	→ P587

\* For SSEL and XSEL, only applicable to the single-axis model.  
 ① is a placeholder for the encoder type (I: incremental / A: absolute).  
 ② is a placeholder for the power supply voltage (1: 100V, 2: single-phase 200V).  
 ③ is a placeholder for the XSEL type name ("J", "K", "P", or "Q").  
 ④ is a placeholder for the power supply voltage (1: 100V, 2: single-phase 200V, 3: 3-phase 200V).

- Slider Type
- Mini
- Standard
- Controllers Integrated
- Rod Type
- Mini
- Standard
- Controllers Integrated
- Table/Arm /Flat Type
- Mini
- Standard
- Gripper/ Rotary Type
- Linear Servo Type
- Cleanroom Type
- Splash Proof
- Controllers
- PMEC /AMEC
- PSEP /ASEP
- ROBO NET
- ERC2
- PCON
- ACON
- SCON
- PSEL
- ASEL
- SSEL
- XSEL
- Pulse Motor
- Servo Motor (24V)
- Servo Motor (200V)
- Linear Servo Motor