

# RCP3-TA4R

ROBO Cylinder Mini Table Type Side-Mounted Motor 40mm Width Pulse Motor Ball Screw

■ Configuration: **RCP3** — **TA4R** — **I** — **28P** —  —  —  —  —

Series — Type — Encoder — Motor — Lead — Stroke — Compatible Controllers — Cable Length — Option

I: Incremental \* The simple absolute encoder is also considered type "I".  
 28P: Pulse motor 28 □ size  
 6 : 6mm  
 4 : 4mm  
 2 : 2mm  
 20: 20mm  
 100: 100mm (10mm pitch increments)  
 P1: PCON  
 RPCON  
 PSEL  
 P3: PMEC  
 PSEP  
 N : None  
 P : 1m  
 S : 3m  
 M : 5m  
 X □ □ : Custom  
 See Options below \* Be sure to specify which side the motor is to be mounted (ML/MR).

\* See page Pre-35 for an explanation of the naming convention.



Pictured: TA3R with left-mounted motor (ML).

Technical References P. A-5

**POINT** Notes on Selection

(1) The load capacity is based on operation at an acceleration of 0.3G (0.2G for the 2mm-lead model, or when used vertically). 0.3G (0.2G for 2mm lead) is the upper limit of the acceleration.

■ Speed vs. Load Capacity  
 Due to the characteristics of the Pulse motor, the RCP3 series' load capacity decreases at high speeds. In the table below, check if your desired speed and load capacity are supported.

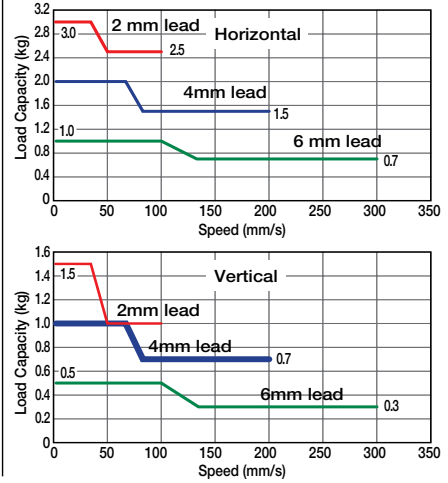

**Actuator Specifications**

■ Lead and Load Capacity (Note 1) Please note that the maximum load capacity decreases as the speed increases.

Model	Feed Screw	Lead (mm)	Max. Load Capacity (Note 1)		Maximum Push Force (N) (Note 2)	Positioning Repeatability (mm)	Stroke (mm)
			Horizontal (kg)	Vertical (kg)			
RCP3-TA4R-I-28P-6-①-②-③-④	Ball Screw	6	~ 1	~ 0.5	15	±0.02	20~100 (10mm increments)
RCP3-TA4R-I-28P-4-①-②-③-④		4	~ 2	~ 1	22		
RCP3-TA4R-I-28P-2-①-②-③-④		2	~ 3	~ 1.5	44		

Legend ① Stroke ② Compatible controller ③ Cable length ④ Options (Note 2) See page A-66 for pushing force graphs. (Unit: mm/s)

■ Stroke and Maximum Speed

Lead	Stroke	
	20 ~ 100 (mm)	Stroke (mm)
Ball Screw	6	300
	4	200
	2	100

① Stroke List

Stroke (mm)	Standard Price
20	-
30	-
40	-
50	-
60	-
70	-
80	-
90	-
100	-

③ Cable List

Type	Cable Symbol	Standard Price
Standard (Robot Cables)	P (1m)	-
	S (3m)	-
	M (5m)	-
Special Lengths	X06 (6m) ~ X10 (10m)	-
	X11 (11m) ~ X15 (15m)	-
	X16 (16m) ~ X20 (20m)	-

\* The RCP3 comes standard with a robot cable.  
 \* See page A-39 for cables for maintenance.

④ Option List

Name	Option Code	See Page	Standard Price
Brake	B	→ A-25	-
Cable exit direction (Top)	CJT	→ A-25	-
Cable exit direction (Outside)	CJO		
Cable exit direction (Bottom)	CJB		
Left-Mounted Motor (Standard)	ML	→ A-33	-
Right-Mounted Motor	MR	→ A-33	-
Reversed-home	NM	→ A-33	-

Actuator Specifications

Item	Description
Drive System	Ball screw ø6mm C10 grade
Lost Motion	0.1mm or less
Base	Material: Aluminum (white alumite treated)
Allowable Dynamic Moment (Note 3)	Ma: 4.2 N·m Mb: 6 N·m Mc: 8.2 N·m
Ambient Operating Temp./Humidity	0~40°C, 85% RH or less (non-condensing)

(Note 3) Based on a 5,000km service life.

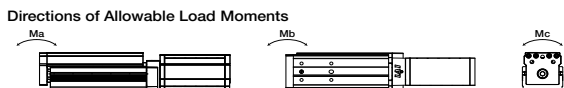

281 RCP3-TA4R

Dimensions

For Special Orders P. A-9

\* Below is a drawing of the left-mounted motor model.

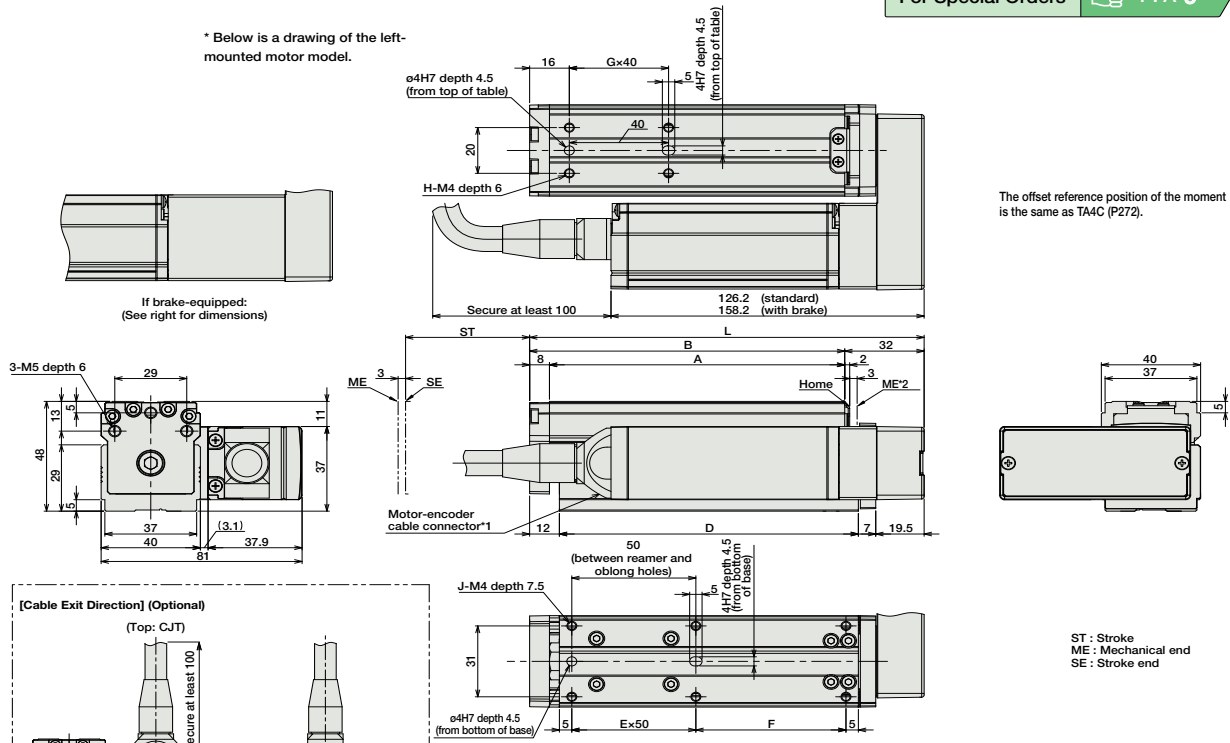

The offset reference position of the moment is the same as TA4C (P272).

ST : Stroke  
ME : Mechanical end  
SE : Stroke end

■ Dimensions/Weight by Stroke

\* Adding a brake will increase the actuator's weight by 0.2kg.

Stroke	20	30	40	50	60	70	80	90	100
L	129	139	149	159	169	179	189	199	209
A	89	99	109	119	129	139	149	159	169
B	97	107	117	127	137	147	157	167	177
D	90.5	100.5	110.5	120.5	130.5	140.5	150.5	160.5	170.5
E	1	1	1	1	2	2	2	2	2
F	30.5	40.5	50.5	60.5	20.5	30.5	40.5	50.5	60.5
G	1	1	1	1	2	2	2	2	2
H	4	4	4	4	6	6	6	6	6
J	6	6	6	6	8	8	8	8	8
Weight (kg)	0.7	0.8	0.8	0.8	0.9	0.9	0.9	1.0	1.0

- \*1 The motor-encoder cable is connected directly to the motor cover of the actuator. See page A-39 for details on cables.
- \*2 When homing, the slider moves to the mechanical end; therefore, please watch for any interference with the surrounding objects.

② Compatible Controllers

The RCP3 series actuators can operate with the controllers below. Select the controller according to your usage.

Name	External View	Model	Description	Max. Positioning Points	Input Voltage	Power Supply Capacity	Standard Price	See Page
Solenoid Valve Type		PMEC-C-28PI-NP-2-①	Easy-to-use controller, even for beginners	3 points	AC100V AC200V	See P481	-	→ P477
		PSEP-C-28PI-NP-2-0	Operable with same signal as solenoid valve. Supports both single and double solenoid types. No homing necessary with simple absolute type.					→ P487
Splash-Proof Solenoid Valve Type		PSEP-CW-28PI-NP-2-0						
Positioner Type		PCON-C-28PI-NP-2-0	Positioning is possible for up to 512 points	512 points	DC24V	2A max.	-	→ P525
Safety-Compliant Positioner Type		PCON-CG-28PI-NP-2-0						
Pulse Train Input Type (Differential Line Driver)		PCON-PL-28PI-NP-2-0	Pulse train input type with different line driver support	(-)	DC24V	2A max.	-	→ P525
Pulse Train Input Type (Open Collector)		PCON-PO-28PI-NP-2-0	Pulse train input type with open collector support					
Serial Communication Type		PCON-SE-28PI-N-0-0	Dedicated to serial communication	64 points				
Field Network Type		RPCON-28P	Dedicated to field network	768 points				→ P503
Program Control Type		PSEL-C-1-28PI-NP-2-0	Programmed operation is possible. Operation is possible on up to 2 axes	1500 points				→ P557

\* This is for the single-axis PSEL.  
\* ① is a placeholder for the power supply voltage (1: 100V, 2: 100~240V).

- Slider Type
- Mini
- Standard
- Controllers Integrated
- Rod Type
- Mini
- Standard
- Controllers Integrated
- Table/Arm /Flat Type
- Mini
- Standard
- Gripper/ Rotary Type
- Linear Servo Type
- Cleanroom Type
- Splash Proof
- Controllers
- PMEC /AMEC
- PSEP /ASEP
- ROBO NET
- ERC2
- PCON
- ACON
- SCON
- PSEL
- ASEL
- SSEL
- XSEL
- Pulse Motor
- Servo Motor (24V)
- Servo Motor (200V)
- Linear Servo Motor