

RCP2-GRST ROBO Cylinder 2-Finger Gripper Long Stroke Slide Type 130~190mm Width Pulse Motor

■ Configuration: **RCP2-GRST-I-20P**

Series: RCP2 — Type: GRST — Encoder: I — Motor: 20P — Deceleration Ratio: — Stroke: — Compatible Controllers: — Cable Length: — Option: —

I: Incremental
* The Simple absolute encoder is also considered type "I".

20P: 20 □ size Pulse motor

1: 1/1 deceleration ratio High-Speed Type
2: 1/2 deceleration ratio Standard Type

P1: PCON
RPCON
PSEL
P3: PMEC
PSEP

N: None
P: 1m
S: 3m
M: 5m
X□□: Custom

See Options below
* Be sure to specify the side from which you want the cable to exit (A0 or A1).

* See page Pre-35 for an explanation of the naming convention.



Technical References P. A-5

- POINT** Notes on Selection
- (1) The maximum opening/closing speed indicates the operating speed on one side. The relative operating speed is twice this value.
 - (2) The maximum gripping force is the sum of the gripping forces of both fingers, at a gripping point where there is no offset or overhang distance. The work piece weight that can be actually moved depends on the friction coefficient between the gripper fingers and the work piece, as well as on the shape of the work pieces. As a rough guide, a work piece's weight should not exceed 1/10 to 1/20 of the gripping force. (See page A-74 for details.)
 - (3) The rated acceleration while moving is 0.3G.

■ Gripping Force Adjustment
The gripping (pushing) force can be adjusted freely within the range of current limits of 20% to 70%.

* The gripping forces in the following diagrams indicate the sums of gripping forces of both fingers.

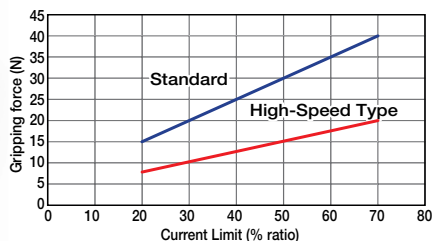

* Please note that, when gripping (pushing), the speed is fixed at 5mm/s.

Actuator Specifications

Lead and Load Capacity

Model	Deceleration Ratio	Max. Gripping Force (N)	Stroke (mm)
RCP2-GRST-I-20P-1-①-②-③-④	1	20	40~100 (20mm increments)
RCP2-GRST-I-20P-2-①-②-③-④	2	40	

Legend: ① Stroke ② Compatible controller ③ Cable length ④ Options

Stroke and Maxi. Opening/Closing Speed

Deceleration Ratio	Stroke	40~100 (mm)
	1	75
2	34	

(Unit: mm/s)

① Stroke List

Stroke (mm)	Standard Price
40	-
60	-
80	-
100	-

③ Cable List

Type	Cable Symbol	Standard Price
Standard Type (Robot Cables)	P (1m)	-
	S (3m)	-
	M (5m)	-
Special Lengths	X06 (6m) ~ X10 (10m)	-
	X11 (11m) ~ X15 (15m)	-
	X16 (16m) ~ X20 (20m)	-
		-

* The standard cable is the motor-encoder integrated robot cable.

* See page A-39 for cables for maintenance.

④ Option List

Name	Option Code	See Page	Standard Price
Reversed-home	NM	→ A-33	-
Cable exiting from bottom	A0	→ A-25	-
Cable exiting from the side	A1	→ A-25	-

* Be sure to specify the side from which you want the cable to exit (A0 or A1).

Actuator Specifications

Item	Description
Drive System	Timing belt + worm/rack gear
Positioning Repeatability	±0.01mm
Backlash	0.2mm or less per side
Lost Motion	-
Guide	Linear guide
Allowable Static Load Moment	Ma: 2.93 N·m Mb: 2.93 N·m Mc: 5.0 N·m
Weight	0.51kg(40-stroke) ~ 0.66kg (100-stroke)
Ambient Operating Temp./Humidity	0~40°C, 85% RH or less (non-condensing)

341 RCP2-GRST

- Slider Type
- Mini
- Standard
- Controllers Integrated
- Rod Type
- Mini
- Standard
- Controllers Integrated
- Table/Arm /Flat Type
- Mini
- Standard
- Gripper/ Rotary Type
- Linear Servo Type
- Cleanroom Type
- Splash-Proof
- Controllers
- PMEC /AMEC
- PSEP /ASEP
- ROBO NET
- ERC2
- PCON
- ACON
- SCON
- PSEL
- ASEL
- SSEL
- XSEL
- Pulse Motor
- Servo Motor (24V)
- Servo Motor (200V)
- Linear Servo Motor

Dimensions

For Special Orders P. A-9

- * The opening side of the slider is the home position.
- *1 The motor-encoder cable is connected here. See page A-39 for details on cables.

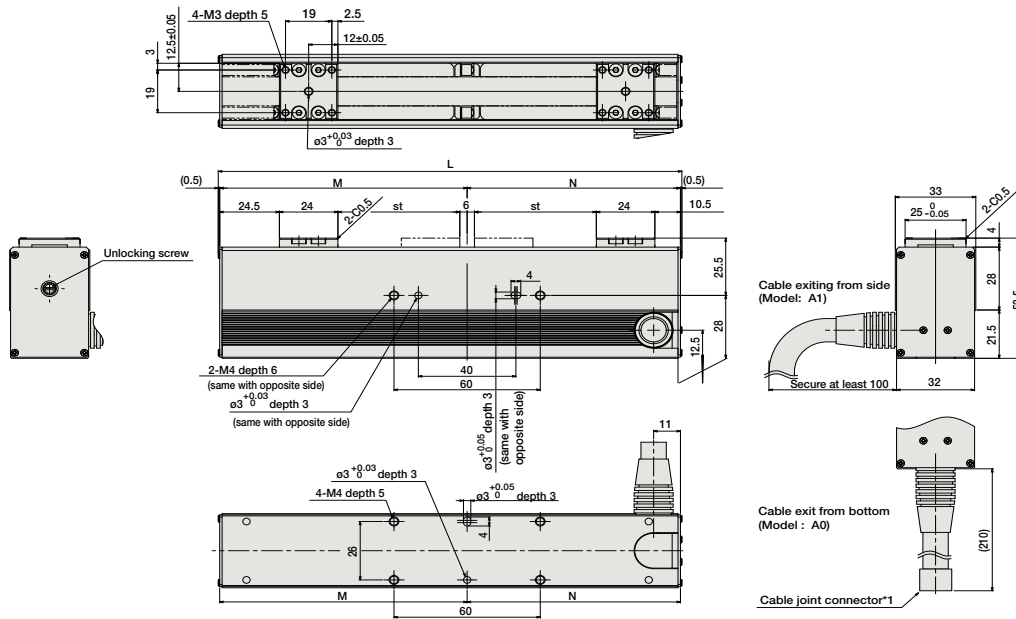

■ Dimensions and Weight by Stroke

Stroke	40	60	80	100
L	130	150	170	190
M	71.5	81.5	91.5	101.5
N	57.5	67.5	77.5	87.5
Weight (kg)	0.51	0.56	0.61	0.66

② Compatible controller

The RCP2 series actuators can operate with the controllers below. Select the controller according to your usage.

Name	External View	Model	Description	Max. Positioning Points	Input Voltage	Power Supply Capacity	Standard Price	See Page
Solenoid Valve Type		PMEC-C-20PI-NP-2-①	Easy-to-use controller, even for beginners	3 points	AC100V AC200V	See P481	-	→ P477
		PSEP-C-20PI-NP-2-0	Operable with same signal as solenoid valve. Supports both single and double solenoid types.					→ P487
Splash-Proof Solenoid Valve Type		PSEP-CW-20PI-NP-2-0	No homing necessary with simple absolute type.					
Positioner Type		PCON-C-20PI-NP-2-0	Positioning is possible for up to 512 points	512 points				
Safety-Compliant Positioner Type		PCON-CG-20PI-NP-2-0						
Pulse Train Input Type (Differential Line Driver)		PCON-PL-20PI-NP-2-0	Pulse train input type with differential line driver support	(-)	DC24V	2A max.		→ P525
Pulse Train Input Type (Open Collector)		PCON-PO-20PI-NP-2-0	Pulse train input type with open collector support					
Serial Communication Type		PCON-SE-20PI-N-0-0	Dedicated to serial communication	64 points				
Field Network Type		RPCON-20P	Dedicated to field network	768 points				→ P503
Program Control Type		PSEL-C-1-20PI-NP-2-0	Programmed operation is possible Operation is possible on up to 2 axes	1500 points				→ P557

* This is for the single-axis PSEL.
* ① is a placeholder for the power supply voltage (1: 100V, 2: 100~240V).

- Slider Type
- Mini
- Standard
- Controllers Integrated
- Rod Type
- Mini
- Standard
- Controllers Integrated
- Table/Arm /Flat Type
- Mini
- Standard
- Gripper/ Rotary Type
- Linear Servo Type
- Cleanroom Type
- Splash-Proof
- Controllers
- PMEC /AMEC
- PSEP /ASEP
- ROBO NET
- ERC2
- PCON
- ACON
- SCON
- PSEL
- ASEL
- SSEL
- XSEL
- Pulse Motor
- Servo Motor (24V)
- Servo Motor (200V)
- Linear Servo Motor