

# Micro Slider **RCL-SA**

**ROBO  
CYLINDER**



Sold & Serviced By:

 **ELECTROMATE**

Toll Free Phone (877) SERV098

Toll Free Fax (877) SERV099

[www.electromate.com](http://www.electromate.com)

[sales@electromate.com](mailto:sales@electromate.com)

# Space-saving, high speed/high acceleration & deceleration, quiet operation A New 20mm wide ultra compact linear servo slider optimal for high-speed load transfer

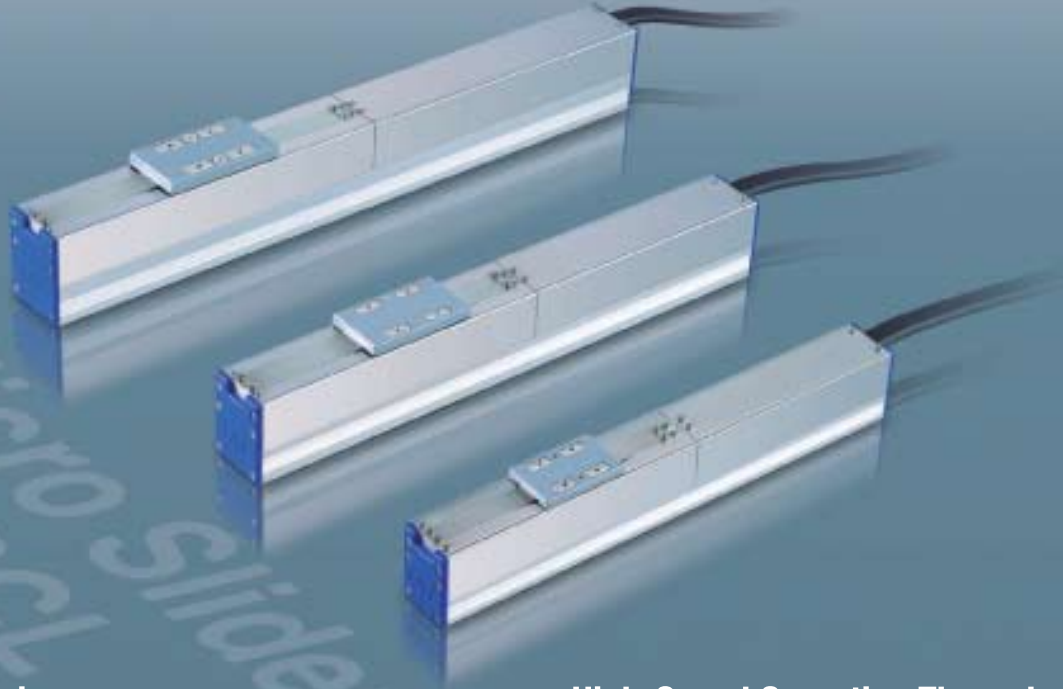

## 1 Space Saving, Ultra compact Linear Servo Slider

The 20mm width facilitates installation in a narrow space (SA1L type). The built-in motor coil eliminates the need for a cable track, so there is no cable disconnection.

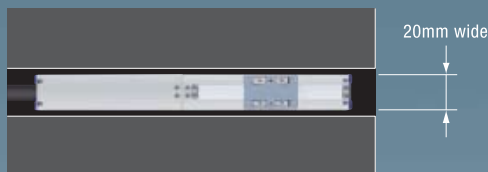

## 2 High-Speed Operation Through the Linear Motor Method

The linear motor method, which has no rotational speed reduction mechanism, makes the slider smaller in size and able to operate at higher speed



## 3 Smooth, quiet movement

The sine wave drive of the three-phase coil enables the slider movement without cogging. Moreover, it virtually has no magnetism leak.

## 5 Controllers appropriate to each application



Three types of controllers:  
ASEL for program operations, SCON for position settings and ROBONET for the field network.  
ACON has a standard type, electromagnetic type, pulse-train input type and serial communication type.  
The optimal controller can be used for each application and purpose.

## 4 Multi-point positioning achieved with a built-in linear encoder

An integrated linear encoder allows positioning at up to 512 points in combination with a small, low-cost ACON controller.



## Lineup / Specifications

Type	Cross-section dimension W x H (mm)	Stroke (mm)	Max Speed (mm/s)	Max Payload (kg)			Rated Thrust (N)	Max Momentary Thrust (N)	Max Acceleration (G)	Encoder	Controller Input Power
				Acceleration Condition	Horizontal	Vertical					
SA1L 	20x30	40	420	0.3G	0.5	-	2	10	Horizontal acceleration 2G	Incremental	DC24V
				max acceleration (2G)	0.15	-					
SA2L 	24x36	48	460	0.3G	1	-	4	18			
				max acceleration (2G)	0.3	-					
SA3L 	28x42	64	600	0.3G	2	-	8	30			
				max acceleration (2G)	0.5	-					

The maximum load capacity decreases when the acceleration is increased. (For details, refer to the operation condition on the back cover.) The term "at maximum acceleration" refers to the horizontal acceleration of 2G (vertical acceleration is not operable). Even when the maximum acceleration is set to 0.3G or less, the maximum load capacity is 0.3G.

## Application Examples

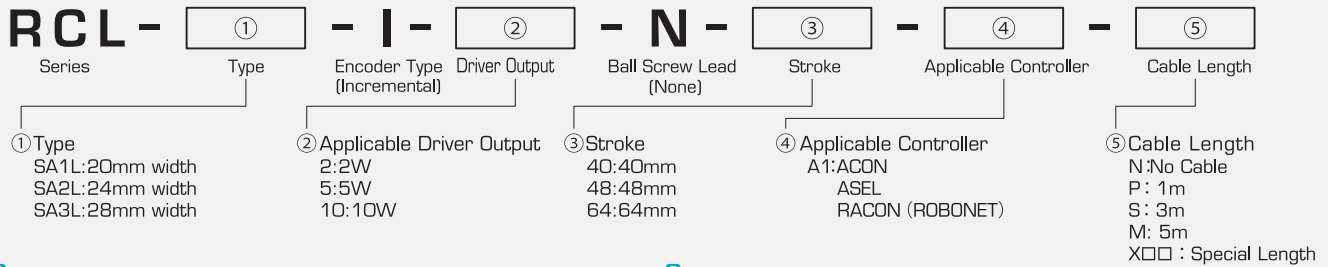

## Types

Width	Stroke	Model
20(mm)	40(mm)	RCL-SA1L-I-2-N-40-A1-□
24(mm)	48(mm)	RCL-SA2L-I-5-N-48-A1-□
28(mm)	64(mm)	RCL-SA3L-I-10-N-64-A-□

In the above model names, □ indicates the cable length symbol. (Refer to the chart on the right)

## Cable Lengths

Type	Cable Length Code
Standard Type (Robot Cable)	P (1m)
	S (3m)
	M (5m)
Special Length	X06(6m) ~ X10(10m)
	X11(11m) ~ X15(15m)
	X16(16m) ~ X20(20m)

The robot cable is the standard RCL cable.

## Specifications

Item	Description
Drive System	Linear Servo
Positioning Repeatability	± 0.1mm
Encoder Resolution	0.042mm
Base	Exclusive Aluminum Push Material
Ambient air temp/humidity	0~40°C, 85% RH or less
Running Life	5000km

Item	Type	Ma	Mb	Mc
Dynamic Allowable Load Moment	SA1L	0.13	0.12	0.21
	SA2L	0.2	0.17	0.25
	SA3L	1.22	1.08	0.34
Overhang Load Length	SA1L	Below 50		
	SA2L	Below 60		
	SA3L	Below 120	Below 80	

## Controllers

	Model
Positioner Type	ACON-C-□I-NP-2-0
Safety Category Type	ACON-CG-□I-NP-2-0
Solenoid Valve Type	ACON-CY-□I-NP-2-0
Pulse-Train Type (Differential)	ACON-PL-□I-NP-2-0
Pulse-Train Type (Open Collector)	ACON-PO-□I-NP-2-0
Serial Type	ACON-SE-□I-N-0-0
Field Network Type*	RACON-□
Program Control Type	ASEL-C-1-□I-NP-2-0

□ indicates the driver output number.

\*When using a field network type, a separate gateway R unit is necessary.

## Application Examples

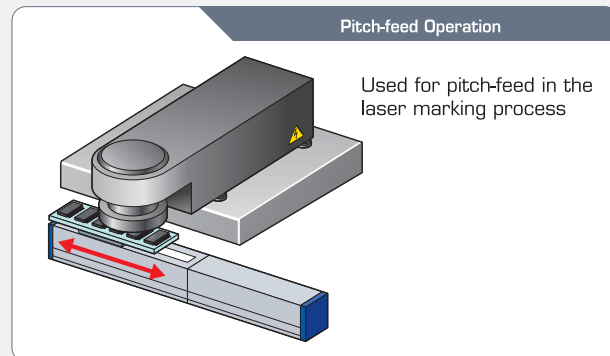
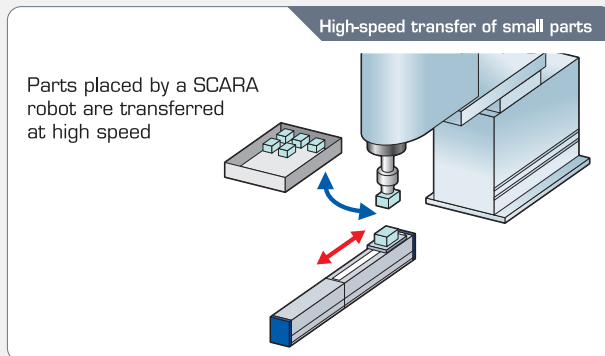

## External Dimensions

RCL-SA1L

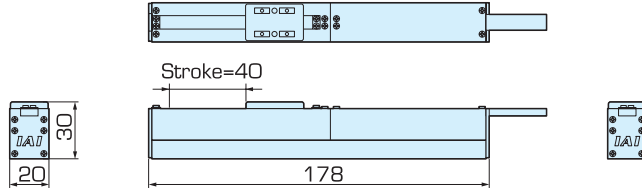

RCL-SA2L

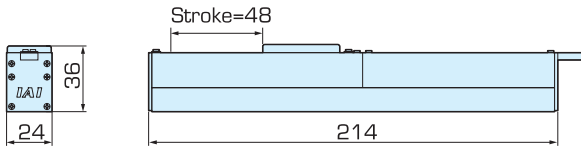

RCL-SA3L

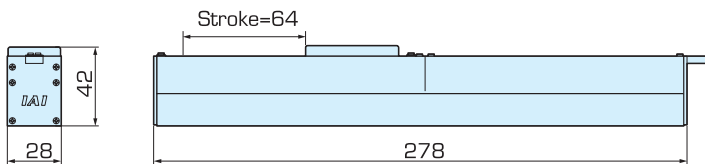

## Operating Conditions

### Setting the acceleration

The acceleration is determined by the load capacity and duty. If the duty is over 70% but not more than 100%, set an appropriate acceleration at which continuous operation is possible (duty = 100%). If the duty is 70% or less, set the acceleration based on a load of 70%.

Load capacity (horizontal) and acceleration

Acceleration (G)	Load Capacity (kg)					
	SA1L		SA2L		SA3L	
	Continuous Operation	Duty 70%	Continuous Operation	Duty 70%	Continuous Operation	Duty 70%
0.1	0.5	0.5	1	1	2	2
0.3			0.85		1.8	
0.5	0.42	0.32	0.5	0.6	1	1.2
1	0.25		0.36	0.45	0.65	0.8
1.5	0.18	0.24	0.3	0.36	0.5	0.6
2	0.15	0.2				

$$\text{Duty} = \frac{\text{Operating Time}}{\text{Operating Time} + \text{Stationary Time}} \times 100$$