



## Gripper Type/Rotary Type

### RCP2 RCS2



RCP2-GRSS



RCP2-GRLS



RCP2-GRS



RCP2-GRM



RCP2-GRST



RCP2-GR3LS



RCP2-GR3SS



RCS2-GR8



RCP2-  
RTBS/RTBSL



RCP2-  
RTB/RTBL



RCP2-  
RTBB/RTBBL



RCP2-  
RTCS/RTCSL



RCP2-  
RTC/RTCL



RCP2-  
RTCB/RTCBL



RCS2-RT6



RCS2-RT6R



RCS2-RT7R

# 331

Gripper Type / Rotary Type

Sold & Serviced By:

**ELECTROMATE**

Toll Free Phone (877) SERV098

Toll Free Fax (877) SERV099

[www.electromate.com](http://www.electromate.com)

[sales@electromate.com](mailto:sales@electromate.com)

<b>RCP2 series</b> Pulse Motor Type	2-Finger Gripper	Mini Slider Type	42mm Width	RCP2-GRSS	<b>333</b>
		Mini Lever Type	42mm Width	RCP2-GRLS	<b>335</b>
		Small Slider Type	69mm Width	RCP2-GRS	<b>337</b>
		Medium Slider Type	74mm Width	RCP2-GRM	<b>339</b>
		Long Stroke Slider Type	130mm Width S 190mm	RCP2-GRST	<b>341</b>
	3-Finger Gripper	Lever Type	62mm Width	RCP2-GR3LS	<b>343</b>
			80mm Width	RCP2-GR3LM	<b>345</b>
		Slider Type	62mm Width	RCP2-GR3SS	<b>347</b>
		80mm Width	RCP2-GR3SM	<b>349</b>	

<b>RCS2 series</b> 200V Servo Motor Type	2 Finger Gripper	Long Stroke Slider Type	104mm Width S 284mm	RCS2-GR8	<b>351</b>

<b>RCP2 series</b> Pulse Motor Type	Rotary	Small Vertical Type	45mm Width	RCP2-RTBS / RTBSL	<b>353</b>
		Small Flat Type	72mm Width	RCP2-RTCS / RTCSL	<b>355</b>
		Medium Vertical Type	50mm Width	RCP2-RTB / RTBL	<b>357</b>
		Medium Flat Type	88mm Width	RCP2-RTC / RTCL	<b>359</b>
		Large Vertical Type	76mm Width	RCP2-RTBB / RTBBL	<b>361</b>
		Large Flat Type	124mm Width	RCP2-RTCB / RTCBL	<b>363</b>

<b>RCS2 series</b> 200V Servo Motor Type	Rotary	Motor Straight Type	64mm Width	RCS2-RT6	<b>365</b>
		Side-Mounted Motor Type	64mm Width	RCS2-RT6R	<b>367</b>
		Side-Mounted Motor, Hollow Axis Type	68mm Width	RCS2-RT7R	<b>369</b>

- Slider Type
- Mini
- Standard
- Controllers Integrated
- Rod Type
- Mini
- Standard
- Controllers Integrated
- Table/Arm/Flat Type
- Mini
- Standard
- Gripper/Rotary Type
- Linear Servo Type
- Cleanroom Type
- Splash-Proof
- Controllers
- PMEC/AMEC
- PSEP/ASEP
- ROBO NET
- ERC2
- PCON
- ACON
- SCON
- PSEL
- ASEL
- SSEL
- XSEL
- Pulse Motor
- Servo Motor (24V)
- Servo Motor (200V)
- Linear Servo Motor

# RCP2-GRSS ROBO Cylinder 2-Finger Gripper Mini Slider Type 42mm Width Pulse Motor

■ Configuration: **RCP2-GRSS-I-20P-30-8**

Series — Type — Encoder — Motor — Deceleration Ratio — Stroke — Compatible Controllers — Cable Length — Option

I: Incremental  
\* The Simple absolute encoder is also considered type "I".

20P: 20 □ size Pulse motor

30: 1/30 deceleration ratio

8: 8mm (4mm per side)

P1: PCON  
RPCON  
PSEL  
P3: PMEC  
PSEP

N: None  
P: 1m  
S: 3m  
M: 5m  
X □ □ : Custom

NM: Reversed-home  
FB: Flange bracket  
SB: Shaft bracket

\* See page Pre-35 for an explanation of the naming convention.



Technical References P. A-5

- POINT**  
Notes on Selection
- (1) The maximum opening/closing speed indicates the operating speed on one side. The relative operating speed is twice this value.
  - (2) The maximum gripping force is the sum of the gripping forces of both fingers, at a gripping point where there is no offset or overhanging distance. The work piece weight that can be actually moved depends on the friction coefficient between the gripper fingers and the work piece, as well as on the shape of the work piece. As a rough guide, a work piece's weight should not exceed 1/10 to 1/20 of the gripping force. (See page A-74 for details.)
  - (3) The rated acceleration while moving is 0.3G.

■ **Gripping Force Adjustment**  
The gripping (pushing) force can be adjusted freely within the range of current limits of 20% to 70%.

\* The gripping forces in the following diagrams indicate the sums of gripping forces of both fingers.

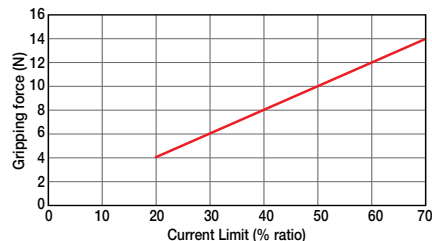

\* Please note that, when gripping (pushing), the speed is fixed at 5mm/s.

## Actuator Specifications

### ■ Lead and Load Capacity

Model	Deceleration Ratio	Max. Gripping Force (N)	Stroke (mm)
RCP2-GRSS-I-20P-30-8-①-②-③	30	14	8 (4 per side)

Legend: ① Compatible controllers ② Cable length ③ Options

### ■ Stroke and Maxi. Opening/Closing Speed

Deceleration Ratio	Stroke	8 (mm)
	30	78

(Unit: mm/s)

### ① Stroke List

Stroke (mm)	Standard Price
8	-

### ② Cable List

Type	Cable Symbol	Standard Price
Standard Type (Robot Cables)	P (1m)	-
	S (3m)	-
	M (5m)	-
Special Lengths	X06 (6m) ~ X10 (10m)	-
	X11 (11m) ~ X15 (15m)	-
	X16 (16m) ~ X20 (20m)	-
		-

\* The standard cable is the motor-encoder integrated robot cable.

\* See page A-39 for cables for maintenance.

### ③ Option List

Name	Option Code	See Page	Standard Price
Reversed-home	NM	→ A-33	-
Flange bracket	FB	→ A-26	-
Shaft bracket	SB	→ A-36	-

### Actuator Specifications

Item	Description
Drive System	Worm gear + helical gear + helical rack
Positioning Repeatability	±0.01mm
Backlash	0.2mm or less per side (constantly pressed out by a spring)
Lost Motion	0.05mm or less per side
Guide	Linear guide
Allowable Static Load Moment	Ma: 0.5 N·m Mb: 0.5 N·m Mc: 1.5 N·m
Weight	0.2kg
Ambient Operating Temp./Humidity	0~40°C, 85% RH or less (non-condensing)

# 333 RCP2-GRSS

- Slider Type
- Mini
- Standard
- Controllers Integrated
- Rod Type
- Mini
- Standard
- Controllers Integrated
- Table/Arm/Flat Type
- Mini
- Standard
- Gripper/Rotary Type
- Linear Servo Type
- Cleanroom Type
- Splash-Proof
- Controllers
- PMEC/AMEC
- PSEP/ASEP
- ROBO NET
- ERC2
- PCON
- ACON
- SCON
- PSEL
- ASEL
- SSEL
- XSEL
- Pulse Motor
- Servo Motor (24V)
- Servo Motor (200V)
- Linear Servo Motor

Dimensions

For Special Orders P. A-9

- \* The opening side of the slider is the home position.
- \*1 The motor-encoder cable is connected here. See page A-39 for details on cables.

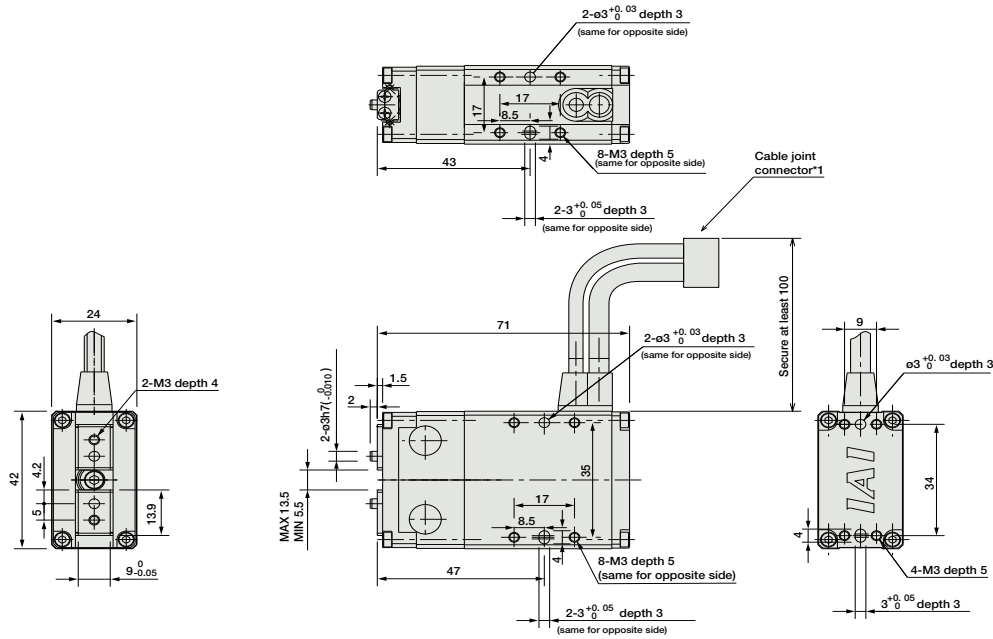

Weight (kg) 0.2

① Compatible Controllers

The RCP2 series actuators can operate with the controllers below. Select the controller according to your usage.

Name	External View	Model	Description	Max. Positioning Points	Input Voltage	Power Supply Capacity	Standard Price	See Page
Solenoid Valve Type		PMEC-C-20PI-NP-2-①	Easy-to-use controller, even for beginners	3 points	AC100V AC200V	P481 See	-	→ P477
Splash-Proof Solenoid Valve Type		PSEP-C-20PI-NP-2-0	Operable with same signal as solenoid valve. Supports both single and double solenoid types. No homing necessary with simple absolute type.					→ P487
Positioner Type		PCON-C-20PI-NP-2-0	Positioning is possible for up to 512 points	512 points	DC24V	2A max.	-	→ P525
Safety-Compliant Positioner Type		PCON-CG-20PI-NP-2-0						
Pulse Train Input Type (Differential Line Driver)		PCON-PL-20PI-NP-2-0	Pulse train input type with differential line driver support	(-)	DC24V	2A max.	-	→ P525
Pulse Train Input Type (Open Collector)		PCON-PO-20PI-NP-2-0	Pulse train input type with open collector support					
Serial Communication Type		PCON-SE-20PI-N-0-0	Dedicated to communication	64 points	DC24V	2A max.	-	→ P503
Field Network Type		RPCON-20P	Dedicated to field network	768 points	DC24V	2A max.	-	→ P503
Program Control Type		PSEL-C-1-20PI-NP-2-0	Programmed operation is possible Operation is possible on up to 2 axes	1500 points	DC24V	2A max.	-	→ P557

\* This is for the single-axis PSEL.  
\* ① is a placeholder for the power supply voltage (1: 100V, 2: 100 ~ 240V).



RCP2-GRSS **334**

- Slider Type
- Mini
- Standard
- Controllers Integrated
- Rod Type
- Mini
- Standard
- Controllers Integrated
- Table/Arm /Flat Type
- Mini
- Standard
- Gripper/ Rotary Type
- Linear Servo Type
- Cleanroom Type
- Splash-Proof
- Controllers
- PMEC /AMEC
- PSEP /ASEP
- ROBO NET
- ERC2
- PCON
- ACON
- SCON
- PSEL
- ASEL
- SSEL
- XSEL
- Pulse Motor
- Servo Motor (24V)
- Servo Motor (200V)
- Linear Servo Motor

# RCP2-GRLS

ROBO Cylinder 2-Finger Gripper Mini Lever Type 42mm Width Pulse Motor

■ Configuration: **RCP2** — **GRLS** — **I** — **20P** — **30** — **180** —  —  —

Series — Type — Encoder — Motor — Deceleration Ratio — Stroke — Compatible Controllers — Cable Length — Option

I: Incremental  
\* The Simple absolute encoder is also considered type "I".

20P: 20 □ size Pulse motor

30: 1/30 deceleration ratio (90 degrees per side)

180: 180 degrees (90 degrees per side)

P1: PCON  
RPCON  
PSEL  
P3: PMEC  
PSEP

N: None  
P: 1m  
S: 3m  
M: 5m  
X□□: Custom

NM: Reversed-home  
FB: Flange bracket  
SB: Shaft bracket

\* See page Pre-35 for an explanation of the naming convention.

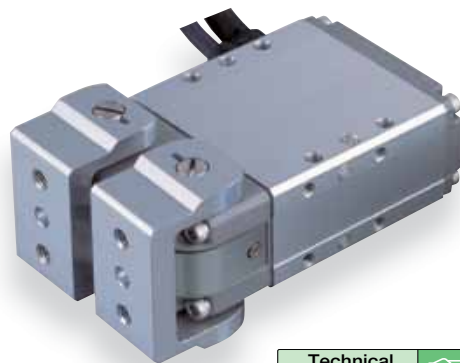

Technical References P. A-5



- (1) The maximum opening/closing speed indicates the operating speed on one side. The relative operating speed is twice this value.
- (2) The maximum gripping force is the sum of the gripping forces of both fingers, at a gripping point where there is no offset or overhang distance. The work piece weight that can be actually moved depends on the friction coefficient between the gripper fingers and the work piece, as well as on the shape of the work piece. As a rough guide, a work piece's weight should not exceed 1/10 to 1/20 of the gripping force. (See page A-77 for details.)
- (3) The rated acceleration while moving is 0.3G.

### ■ Gripping Force Adjustment

The gripping (pushing) force can be adjusted freely within the range of current limits of 20% to 70%.

\* The gripping forces in the following diagrams indicate the sums of gripping forces of both fingers.

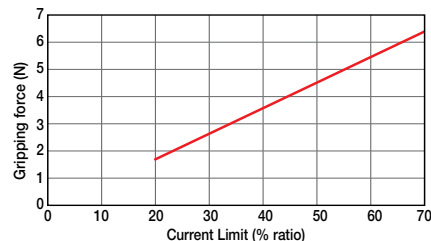

\* Please note that, when gripping (pushing), the speed is fixed at 5 degrees/s.

### Actuator Specifications

#### ■ Lead and Load Capacity

Model	Deceleration Ratio	Max. Gripping Force (N)	Stroke (deg)
RCP2-GRLS-I-20P-30-180-①-②-③	30	6.4	180 (90 per side)

Legend: ① Compatible controllers ② Cable length ③ Options

#### ■ Stroke and Maxi. Opening/Closing Speed

Deceleration Ratio	Stroke	180 (deg)
	30	600

(Unit: degrees/s)

#### ① Stroke List

Stroke (deg)	Standard Price
180	-

#### ② Cable List

Type	Cable Symbol	Standard Price
Standard Type (Robot Cables)	P (1m)	-
	S (3m)	-
	M (5m)	-
Special Lengths	X06 (6m) ~ X10 (10m)	-
	X11 (11m) ~ X15 (15m)	-
	X16 (16m) ~ X20 (20m)	-
		-

\* The standard cable is the motor-encoder integrated robot cable.

\* See page A-39 for cables for maintenance.

#### ③ Option List

Name	Option Code	See Page	Standard Price
Reversed-home	NM	→ A-33	-
Flange bracket	FB	→ A-26	-
Shaft bracket	SB	→ A-36	-

#### Actuator Specifications

Item	Description
Drive System	Worm gear + helical gear
Positioning Repeatability	±0.01mm
Backlash	1 degree or less per side (constantly pressed out by a spring)
Lost Motion	1 degree or less
Guide	-
Allowable Static Load Moment	-
Weight	0.2kg
Ambient Operating Temp./Humidity	0~40°C, 85% RH or less (non-condensing)

# 335

RCP2-GRLS

Dimensions

For Special Orders P. A-9

- \* The opening side of the slider is the home position.
- \*1 The motor-encoder cable is connected here. See page A-39 for details on cables.

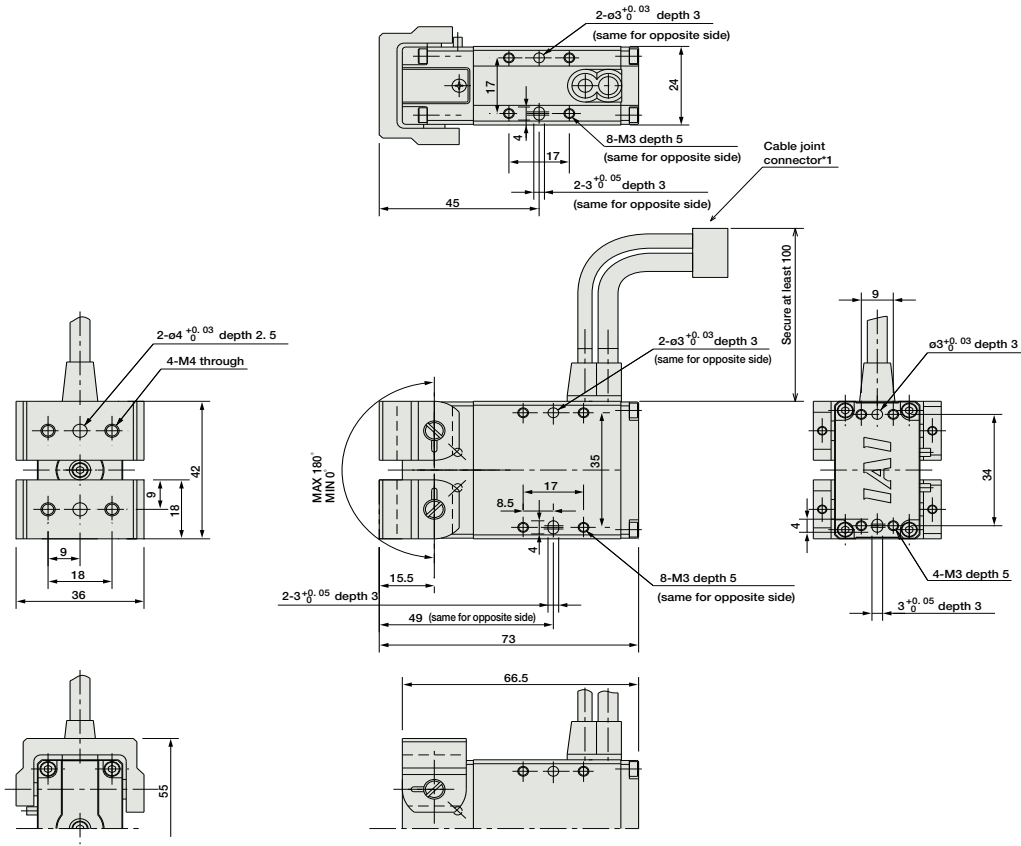

Weight (kg) 0.2

① Compatible Controllers

The RCP2 series actuators can operate with the controllers below. Select the controller according to your usage.

Name	External View	Model	Description	Max. Positioning Points	Input Voltage	Power Supply Capacity	Standard Price	See Page
Solenoid Valve Type		PMEC-C-20PI-NP-2-①	Easy-to-use controller, even for beginners	3 points	AC100V AC200V	See P481	-	→ P477
		PSEP-C-20PI-NP-2-0	Operable with same signal as solenoid valve. Supports both single and double solenoid types. No homing necessary with simple absolute type.				-	→ P487
Splash-Proof Solenoid Valve Type		PSEP-CW-20PI-NP-2-0					-	
Positioner Type		PCON-C-20PI-NP-2-0	Positioning is possible for up to 512 points	512 points	DC24V	2A max.	-	→ P525
Safety-Compliant Positioner Type		PCON-CG-20PI-NP-2-0					-	
Pulse Train Input Type (Differential Line Driver)		PCON-PL-20PI-NP-2-0	Pulse train input type with differential line driver support	(-)	DC24V	2A max.	-	→ P525
Pulse Train Input Type (Open Collector)		PCON-PO-20PI-NP-2-0	Pulse train input type with open collector support				-	
Serial Communication Type		PCON-SE-20PI-N-0-0	Dedicated to serial communication	64 points			-	
Field Network Type		RPOON-20P	Dedicated to field network	768 points			-	→ P503
Program Control Type		PSEL-C-1-20PI-NP-2-0	Programmed operation is possible. Operation is possible on up to 2 axes	1500 points			-	→ P557

\* This is for the single-axis PSEL.  
 \* ① is a placeholder for the power supply voltage (1: 100V, 2: 100~240V).

- Slider Type
- Mini
- Standard
- Controllers Integrated
- Rod Type
- Mini
- Standard
- Controllers Integrated
- Table/Arm /Flat Type
- Mini
- Standard
- Gripper/ Rotary Type
- Linear Servo Type
- Cleanroom Type
- Splash-Proof
- Controllers
- PMEC /AMEC
- PSEP /ASEP
- ROBO NET
- ERC2
- PCON
- ACON
- SCON
- PSEL
- ASEL
- SSEL
- XSEL
- Pulse Motor
- Servo Motor (24V)
- Servo Motor (200V)
- Linear Servo Motor

# RCP2-GRS

ROBO Cylinder 2-Finger Gripper Mini Slider Type 69mm Width Pulse Motor

■ Configuration: **RCP2** — **GRS** — **I** — **20P** — **1** — **10** —  —  —

Series — Type — Encoder — Motor — Deceleration Ratio — Stroke — Compatible Controllers — Cable Length — Option

I: Incremental  
\* The Simple absolute encoder is also considered type "I".

20P: 20 □ size Pulse motor  
1: 1/1 deceleration ratio  
10: 10mm (5mm per side)

P1: PCON  
RPCON  
PSEL  
P3: PMEC  
PSEP

N: None  
P: 1m  
S: 3m  
M: 5m  
X  : Custom  
R  : Robot cable

SB: Shaft bracket  
FB: Flange bracket

\* See page Pre-35 for an explanation of the naming convention.



Technical References P. A-5

- POINT**  
Notes on Selection
- (1) The maximum opening/closing speed indicates the operating speed on one side. The relative operating speed is twice this value.
  - (2) The maximum gripping force is the sum of the gripping forces of both fingers, at a gripping point where there is no offset or overhang distance. The work piece weight that can be actually moved depends on the friction coefficient between the gripper fingers and the work piece, as well as on the shape of the work piece. As a rough guide, a work piece's weight should not exceed 1/10 to 1/20 of the gripping force. (See page A-74 for details.)
  - (3) The rated acceleration while moving is 0.3G.

■ **Gripping Force Adjustment**  
The gripping (pushing) force can be adjusted freely within the range of current limits of 20% to 70%.

\* The gripping forces in the following diagrams indicate the sums of gripping forces of both fingers.

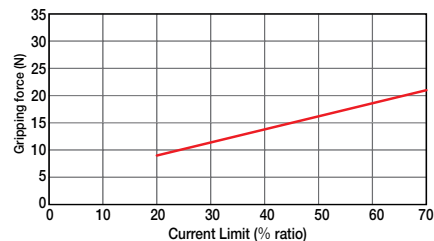

\* Please note that, when gripping (pushing), the speed is fixed at 5mm/s.

### Actuator Specifications

#### ■ Lead and Load Capacity

Model	Deceleration Ratio	Max. Gripping Force (N)	Stroke (mm)
RCP2-GRS-I-20P-1-10-①-②-③	1	21	10 (5 per side)

Legend: ① Compatible controllers ② Cable length ③ Options

#### ■ Stroke and Maxi. Opening/Closing Speed

Deceleration Ratio	Stroke	10 (mm)
	1	33.3

(Unit: mm/s)

#### ① Stroke List

Stroke (mm)	Standard Price
10	-

#### ② Cable List

Type	Cable Symbol	Standard Price
Standard Type	P (1m)	-
	S (3m)	-
	M (5m)	-
Special Lengths	X06 (6m) ~ X10 (10m)	-
	X11 (11m) ~ X15 (15m)	-
	X16 (16m) ~ X20 (20m)	-
Robot Cable	R01 (1m) ~ R03 (3m)	-
	R04 (4m) ~ R05 (5m)	-
	R06 (6m) ~ R10 (10m)	-
	R11 (11m) ~ R15 (15m)	-
	R16 (16m) ~ R20 (20m)	-

\* See page A-39 for cables for maintenance.

#### ③ Option List

Name	Option Code	See Page	Standard Price
Flange bracket	FB	→ A-26	-
Shaft bracket	SB	→ A-36	-

#### Actuator Specifications

Item	Description
Drive System	Timing belt + trapezoidal screw (1.5 lead)
Positioning Repeatability	±0.01mm
Backlash	0.15mm or less per side (constantly pressed out by a spring)
Lost Motion	0.1mm or less per side
Guide	Cross roller guide
Allowable Static Load Moment	Ma: 6.3 N·m Mb: 6.3 N·m Mc: 7.0 N·m
Weight	0.36kg
Ambient Operating Temp./Humidity	0~40°C, 85% RH or less (non-condensing)

# 337

RCP2-GRS

Dimensions

CAD drawings can be downloaded from IAI website. [www.intelligentactuator.com](http://www.intelligentactuator.com)

For Special Order P. A-9



- \* The opening side of the slider is the home position.
- \*1 The motor-encoder cable is connected here. See page A-39 for details on cables.

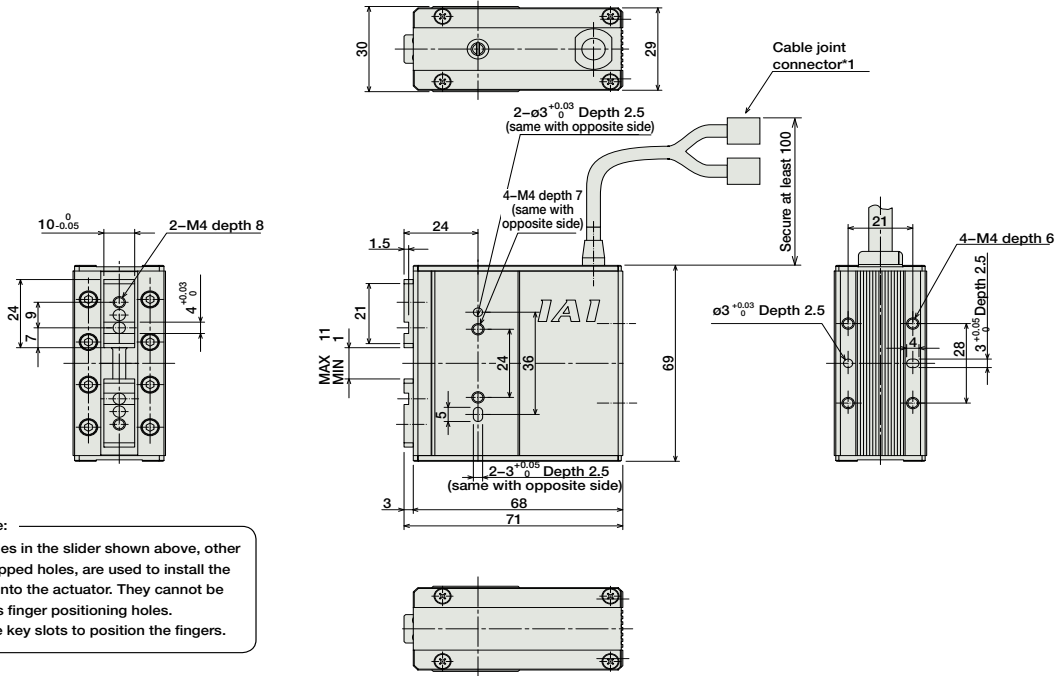

Note:  
The holes in the slider shown above, other than tapped holes, are used to install the slider onto the actuator. They cannot be used as finger positioning holes. Use the key slots to position the fingers.

Weight (kg) 0.36

① Compatible Controllers

The RCP2 series actuators can operate with the controllers below. Select the controller according to your usage.

Name	External View	Model	Description	Max. Positioning Points	Input Voltage	Power Supply Capacity	Standard Price	See Page
Solenoid Valve Type		PMEC-C-20PI-NP-2-①	Easy-to-use controller, even for beginners	3 points	AC100V AC200V	See P481	-	→ P477
		PSEP-C-20PI-NP-2-0	Operable with same signal as solenoid valve. Supports both single and double solenoid types. No homing necessary with simple absolute type.				-	→ P487
Splash-Proof Solenoid Valve Type		PSEP-CW-20PI-NP-2-0					-	
Positioner Type		PCON-C-20PI-NP-2-0	Positioning is possible for up to 512 points	512 points	DC24V	2A max.	-	→ P625
Safety-Compliant Positioner Type		PCON-CG-20PI-NP-2-0					-	
Pulse Train Input Type (Differential Line Driver)		PCON-PL-20PI-NP-2-0	Pulse train input type with differential line driver support	(-)	DC24V	2A max.	-	→ P625
Pulse Train Input Type (Open Collector)		PCON-PO-20PI-NP-2-0	Pulse train input type with open collector support				-	
Serial Communication Type		PCON-SE-20PI-N-0-0	Dedicated to serial communication	64 points			-	
Field Network Type		RPCON-20P	Dedicated to field network	768 points			-	→ P503
Program Control Type		PSEL-C-1-20PI-NP-2-0	Programmed operation is possible. Operation is possible on up to 2 axes	1500 points			-	→ P557

\* This is for the single-axis PSEL.  
\* ① is a placeholder for the power supply voltage (1: 100V, 2: 100-240V).



RCP2-GRS **338**

- Slider Type
- Mini
- Standard
- Controllers Integrated
- Rod Type
- Mini
- Standard
- Controllers Integrated
- Table/Arm /Flat Type
- Mini
- Standard
- Gripper/ Rotary Type
- Linear Servo Type
- Cleanroom Type
- Splash-Proof
- Controllers
- PMEC /AMEC
- PSEP /ASEP
- ROBO NET
- ERC2
- PCON
- ACON
- SCON
- PSEL
- ASEL
- SSEL
- XSEL
- Pulse Motor
- Servo Motor (24V)
- Servo Motor (200V)
- Linear Servo Motor



# RCP2-GRM

ROBO Cylinder 2-Finger Gripper Medium Slider Type 74mm Width Pulse Motor

■ Configuration: **RCP2** — **GRM** — **I** — **28P** — **1** — **14** —  —  —

Series — Type — Encoder — Motor — Deceleration Ratio — Stroke — Compatible Controllers — Cable Length — Option

I: Incremental  
\* The Simple absolute encoder is also considered type "I".

28P: 28 □ size Pulse motor

1: 1/1 deceleration ratio

14: 14mm (7mm per side)

P1: PCON  
RPCON  
PSEL  
P3: PMEC  
PSEP

N: None  
P: 1m  
S: 3m  
M: 5m  
X □: Custom  
R □: Robot cable

SB: Shaft bracket  
FB: Flange bracket

\* See page Pre-35 for explanation of each code that makes up the configuration name.



Technical References P. A-5

- POINT**  
Notes on Selection
- (1) The maximum opening/closing speed indicates the operating speed on one side. The relative operating speed is twice this value.
  - (2) The maximum gripping force is the sum of the gripping forces of both fingers, at a gripping point where there is no offset or overhang distance. The work piece weight that can be actually moved depends on the friction coefficient between the gripper fingers and the work piece, as well as on the shape of the work pieces. As a rough guide, a work piece's weight should not exceed 1/10 to 1/20 of the gripping force. (See page A-74 for details.)
  - (3) The rated acceleration while moving is 0.3G.

■ Gripping Force Adjustment  
The gripping (pushing) force can be adjusted freely within the range of current limits of 20% to 70%.

\* The gripping forces in the following diagrams indicate the sums of gripping forces of both fingers.

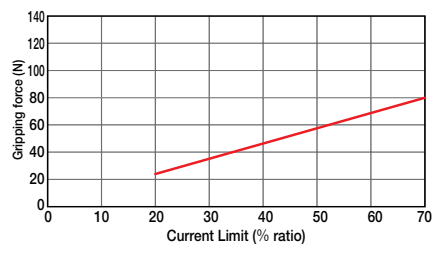

\* Please note that, when gripping (pushing), the speed is fixed at 5mm/s.

**Actuator Specifications**

■ Lead and Load Capacity

Model	Deceleration Ratio	Max. Gripping Force (N)	Stroke (mm)
RCP2-GRM-I-28P-1-14-①-②-③	1	80	14

Legend: ① Compatible controllers ② Cable length ③ Options

■ Stroke and Maxi. Opening/Closing Speed

Deceleration Ratio	Stroke	14 (mm)
	1	36.7

(Unit: mm/s)

**Stroke List**

Stroke (mm)	Standard Price
14	-

**② Cable List**

Type	Cable Symbol	Standard Price
Standard Type	P (1m)	-
	S (3m)	-
	M (5m)	-
Special Lengths	X06 (6m) ~ X10 (10m)	-
	X11 (11m) ~ X15 (15m)	-
	X16 (16m) ~ X20 (20m)	-
	R01 (1m) ~ R03 (3m)	-
Robot Cable	R04 (4m) ~ R05 (5m)	-
	R06 (6m) ~ R10 (10m)	-
	R11 (11m) ~ R15 (15m)	-
	R16 (16m) ~ R20 (20m)	-
	R16 (16m) ~ R20 (20m)	-

\* See page A-39 for cables for maintenance.

**③ Option List**

Name	Option Code	See Page	Standard Price
Flange bracket	FB	→ A-26	-
Shaft bracket	SB	→ A-36	-

**Actuator Specifications**

Item	Description
Drive System	Timing belt + trapezoidal screw (1.5 lead)
Positioning Repeatability	±0.01mm
Backlash	0.15mm or less per side (constantly pressed out by a spring)
Lost Motion	0.1mm or less per side
Guide	Cross roller guide
Allowable Static Load Moment	Ma: 6.3 N·m Mb: 6.3 N·m Mc: 8.3 N·m
Weight	0.5kg
Ambient Operating Temp./Humidity	0~40°C, 85% RH or less (non-condensing)

# 339 RCP2-GRM

- Slider Type
- Mini
- Standard
- Controllers Integrated
- Rod Type
- Mini
- Standard
- Controllers Integrated
- Table/Arm /Flat Type
- Mini
- Standard
- Gripper/ Rotary Type
- Linear Servo Type
- Cleanroom Type
- Splash-Proof
- Controllers
- PMEC /AMEC
- PSEP /ASEP
- ROBO NET
- ERC2
- PCON
- ACON
- SCON
- PSEL
- ASEL
- SSEL
- XSEL
- Pulse Motor
- Servo Motor (24V)
- Servo Motor (200V)
- Linear Servo Motor

Dimensions

CAD drawings can be downloaded from IAI website. [www.intelligentactuator.com](http://www.intelligentactuator.com)

For Special Order P. A-9



- \* The opening side of the slider is the home position.
- \*1 The motor-encoder cable is connected here. See page A-39 for details on cables.

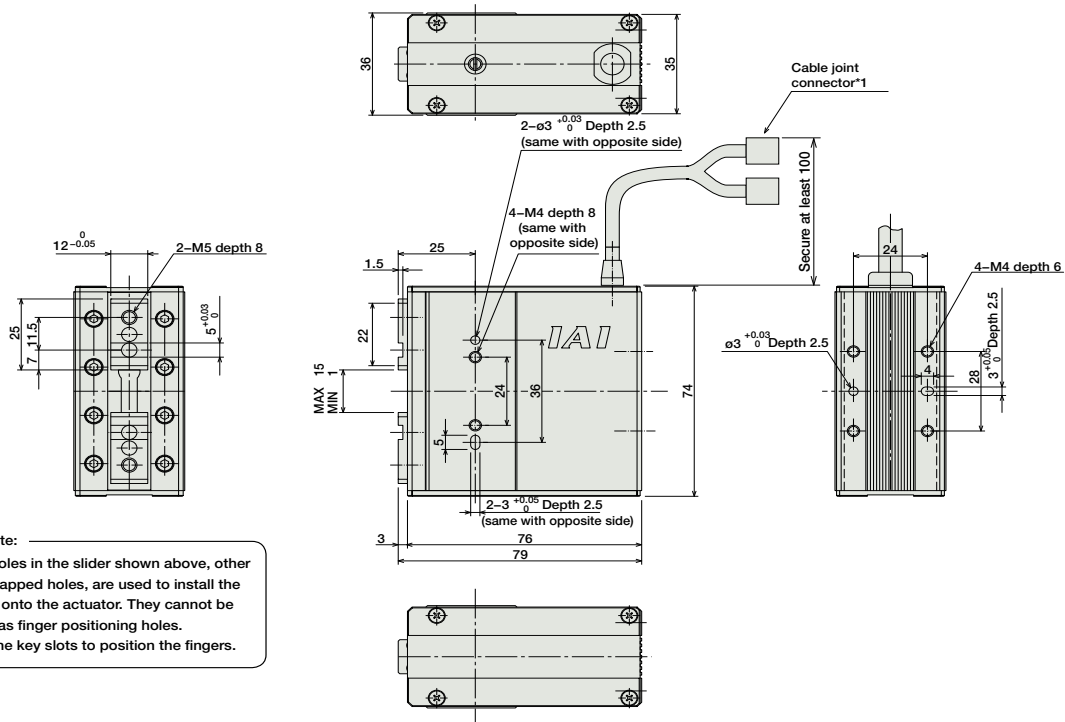

Note:  
The holes in the slider shown above, other than tapped holes, are used to install the slider onto the actuator. They cannot be used as finger positioning holes. Use the key slots to position the fingers.

Weight (kg) 0.5

① Compatible Controllers

The RCP2 series actuators can operate with the controllers below. Select the controller according to your usage.

Name	External View	Model	Description	Max. Positioning Points	Input Voltage	Power Supply Capacity	Standard Price	See Page
Solenoid Valve Type		PMEC-C-28PI-NP-2-①	Easy-to-use controller, even for beginners	3 points	AC100V AC200V	See P481	-	→ P477
		PSEP-C-28PI-NP-2-0	Operable with same signal as solenoid valve. Supports both single and double solenoid types.				-	→ P487
Splash-Proof Solenoid Valve Type		PSEP-CW-28PI-NP-2-0	No homing necessary with simple absolute type.				-	
Positioner Type		PCON-C-28PI-NP-2-0	Positioning is possible for up to 512 points	512 points	DC24V	2A max.	-	→ P525
Safety-Compliant Positioner Type		PCON-CG-28PI-NP-2-0					-	
Pulse Train Input Type (Differential Line Driver)		PCON-PL-28PI-NP-2-0	Pulse train input type with differential line driver support	(-)	DC24V	2A max.	-	→ P525
Pulse Train Input Type (Open Collector)		PCON-PO-28PI-NP-2-0	Pulse train input type with open collector support				-	
Serial Communication Type		PCON-SE-28PI-N-0-0	Dedicated to serial communication	64 points			-	
Field Network Type		RPCON-28P	Dedicated to field network	768 points			-	→ P503
Program Control Type		PSEL-C-1-28PI-NP-2-0	Programmed operation is possible Operation is possible on up to 2 axes	1500 points			-	→ P557

\* This is for the single-axis PSEL.  
\* ① is a placeholder for the power supply voltage (1: 100V, 2: 100~240V).



RCP2-GRM **340**

- Slider Type
- Mini
- Standard
- Controllers Integrated
- Rod Type
- Mini
- Standard
- Controllers Integrated
- Table/Arm /Flat Type
- Mini
- Standard
- Gripper/ Rotary Type
- Linear Servo Type
- Cleanroom Type
- Splash-Proof
- Controllers
- PMEC /AMEC
- PSEP /ASEP
- ROBO NET
- ERC2
- PCON
- ACON
- SCON
- PSEL
- ASEL
- SSEL
- XSEL
- Pulse Motor
- Servo Motor (24V)
- Servo Motor (200V)
- Linear Servo Motor

# RCP2-GRST ROBO Cylinder 2-Finger Gripper Long Stroke Slide Type 130~190mm Width Pulse Motor

■ Configuration: **RCP2-GRST-I-20P**

Series: RCP2 | Type: GRST | Encoder: I | Motor: 20P

Deceleration Ratio: 1 | Stroke: 20mm | Compatible Controllers: P1: PCON, P2: PCON, P3: PMEC, PSEP

Cable Length: N: None, P: 1m, S: 3m, M: 5m, X: Custom

Option: See Options below

\* See page Pre-35 for an explanation of the naming convention.



Technical References P. A-5

- POINT** Notes on Selection
- The maximum opening/closing speed indicates the operating speed on one side. The relative operating speed is twice this value.
  - The maximum gripping force is the sum of the gripping forces of both fingers, at a gripping point where there is no offset or overhang distance. The work piece weight that can be actually moved depends on the friction coefficient between the gripper fingers and the work piece, as well as on the shape of the work pieces. As a rough guide, a work piece's weight should not exceed 1/10 to 1/20 of the gripping force. (See page A-74 for details.)
  - The rated acceleration while moving is 0.3G.

■ Gripping Force Adjustment  
The gripping (pushing) force can be adjusted freely within the range of current limits of 20% to 70%.

\* The gripping forces in the following diagrams indicate the sums of gripping forces of both fingers.

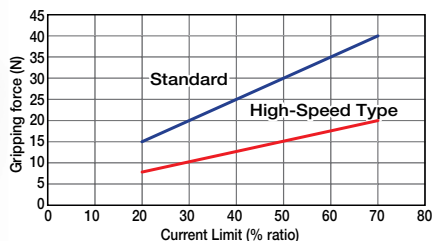

\* Please note that, when gripping (pushing), the speed is fixed at 5mm/s.

## Actuator Specifications

### Lead and Load Capacity

Model	Deceleration Ratio	Max. Gripping Force (N)	Stroke (mm)
RCP2-GRST-I-20P-1-①-②-③-④	1	20	40~100 (20mm increments)
RCP2-GRST-I-20P-2-①-②-③-④	2	40	

Legend: ① Stroke ② Compatible controller ③ Cable length ④ Options

### Stroke and Maxi. Opening/Closing Speed

Deceleration Ratio	Stroke	40~100 (mm)
	1	75
2	34	

(Unit: mm/s)

### ① Stroke List

Stroke (mm)	Standard Price
40	-
60	-
80	-
100	-

### ③ Cable List

Type	Cable Symbol	Standard Price
Standard Type (Robot Cables)	P (1m)	-
	S (3m)	-
	M (5m)	-
Special Lengths	X06 (6m) ~ X10 (10m)	-
	X11 (11m) ~ X15 (15m)	-
	X16 (16m) ~ X20 (20m)	-
		-

\* The standard cable is the motor-encoder integrated robot cable.

\* See page A-39 for cables for maintenance.

### ④ Option List

Name	Option Code	See Page	Standard Price
Reversed-home	NM	→ A-33	-
Cable exiting from bottom	A0	→ A-25	-
Cable exiting from the side	A1	→ A-25	-

\* Be sure to specify the side from which you want the cable to exit (A0 or A1).

### Actuator Specifications

Item	Description
Drive System	Timing belt + worm/rack gear
Positioning Repeatability	±0.01mm
Backlash	0.2mm or less per side
Lost Motion	-
Guide	Linear guide
Allowable Static Load Moment	Ma: 2.93 N·m Mb: 2.93 N·m Mc: 5.0 N·m
Weight	0.51kg(40-stroke) ~ 0.66kg (100-stroke)
Ambient Operating Temp./Humidity	0~40°C, 85% RH or less (non-condensing)

# 341 RCP2-GRST

- Slider Type
- Mini
- Standard
- Controllers Integrated
- Rod Type
- Mini
- Standard
- Controllers Integrated
- Table/Arm /Flat Type
- Mini
- Standard
- Gripper/ Rotary Type
- Linear Servo Type
- Cleanroom Type
- Splash-Proof
- Controllers
- PMEC /AMEC
- PSEP /ASEP
- ROBO NET
- ERC2
- PCON
- ACON
- SCON
- PSEL
- ASEL
- SSEL
- XSEL
- Pulse Motor
- Servo Motor (24V)
- Servo Motor (200V)
- Linear Servo Motor

Dimensions

CAD drawings can be downloaded from IAI website. [www.intelligentactuator.com](http://www.intelligentactuator.com)



- \* The opening side of the slider is the home position.
- \*1 The motor-encoder cable is connected here. See page A-39 for details on cables.

For Special Orders P. A-9

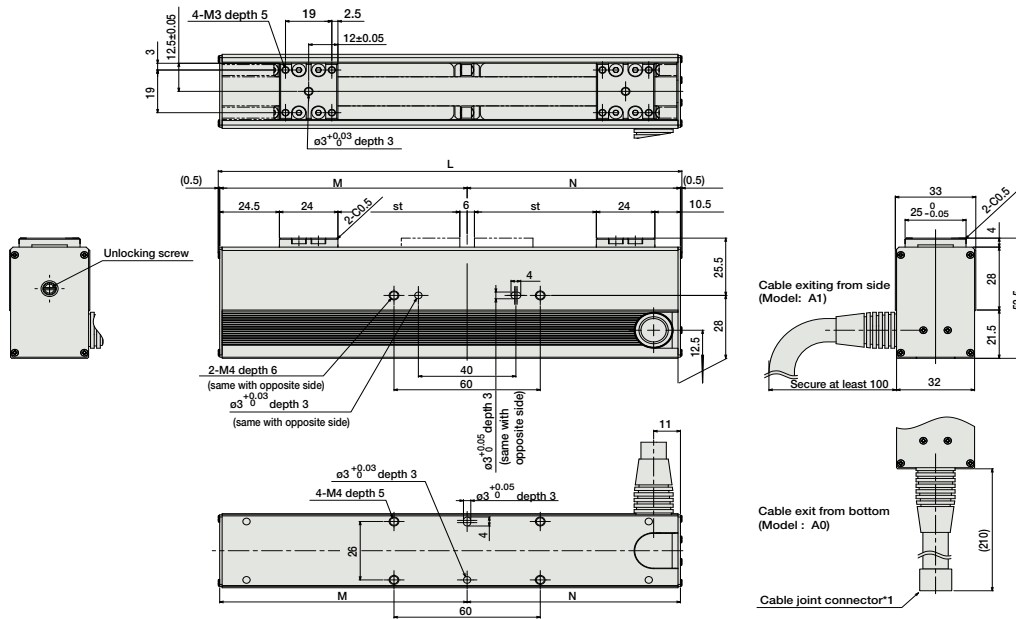

■ Dimensions and Weight by Stroke

Stroke	40	60	80	100
L	130	150	170	190
M	71.5	81.5	91.5	101.5
N	57.5	67.5	77.5	87.5
Weight (kg)	0.51	0.56	0.61	0.66

② Compatible controller

The RCP2 series actuators can operate with the controllers below. Select the controller according to your usage.

Name	External View	Model	Description	Max. Positioning Points	Input Voltage	Power Supply Capacity	Standard Price	See Page
Solenoid Valve Type		PMEC-C-20PI-NP-2-①	Easy-to-use controller, even for beginners	3 points	AC100V AC200V	See P481	-	→ P477
		PSEP-C-20PI-NP-2-0	Operable with same signal as solenoid valve. Supports both single and double solenoid types.				-	→ P487
Splash-Proof Solenoid Valve Type		PSEP-CW-20PI-NP-2-0	No homing necessary with simple absolute type.				-	
Positioner Type		PCON-C-20PI-NP-2-0	Positioning is possible for up to 512 points	512 points	DC24V	2A max.	-	→ P525
Safety-Compliant Positioner Type		PCON-CG-20PI-NP-2-0					-	
Pulse Train Input Type (Differential Line Driver)		PCON-PL-20PI-NP-2-0	Pulse train input type with differential line driver support	(-)	DC24V	2A max.	-	→ P525
Pulse Train Input Type (Open Collector)		PCON-PO-20PI-NP-2-0	Pulse train input type with open collector support				-	
Serial Communication Type		PCON-SE-20PI-N-0-0	Dedicated to serial communication	64 points			-	
Field Network Type		RPCON-20P	Dedicated to field network	768 points			-	→ P503
Program Control Type		PSEL-C-1-20PI-NP-2-0	Programmed operation is possible Operation is possible on up to 2 axes	1500 points			-	→ P557

\* This is for the single-axis PSEL.  
\* ① is a placeholder for the power supply voltage (1: 100V, 2: 100~240V).

- Slider Type
- Mini
- Standard
- Controllers Integrated
- Rod Type
- Mini
- Standard
- Controllers Integrated
- Table/Arm /Flat Type
- Mini
- Standard
- Gripper/ Rotary Type
- Linear Servo Type
- Cleanroom Type
- Splash-Proof
- Controllers
- PMEC /AMEC
- PSEP /ASEP
- ROBO NET
- ERC2
- PCON
- ACON
- SCON
- PSEL
- ASEL
- SSEL
- XSEL
- Pulse Motor
- Servo Motor (24V)
- Servo Motor (200V)
- Linear Servo Motor



RCP2-GRST **342**

# RCP2-GR3LS

ROBO Cylinder 3-Finger Gripper Lever Type 62mm Width Pulse Motor

■ Configuration: **RCP2- GR3LS- I - 28P - 30 - 19** -  -  -

Series — Type — Encoder — Motor — Deceleration Ratio — Stroke — Compatible Controllers — Cable Length — Option

I: Incremental  
\* The Simple absolute encoder is also considered type "I".

28P: 28 □ size Pulse motor  
30: 1/30 deceleration ratio  
19: 19 degrees

P1: PCON  
RPCON  
PSEL  
P3: PMEC  
PSEP

N: None  
P: 1m  
S: 3m  
M: 5m  
X □ □ : Custom  
R □ □ : Robot cable

FB: Flange bracket  
SB: Shaft bracket

\* See page Pre-35 for an explanation of the naming convention.



Technical References P. A-5

- POINT** Notes on Selection
- (1) The maximum opening/closing speed indicates the operating speed on one side. The relative operating speed is twice this value.
  - (2) The maximum gripping force is the sum of the gripping forces of all fingers with gripping point distance of 10mm and no overhang distance. For the actual transportable work piece weight, see explanation on the right, or page A-77.
  - (3) The rated acceleration while moving is 0.3G.

### ■ Gripping Force vs. Current Limit Lever Type (GR3LS/GR3LM)

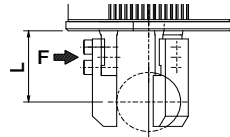

\* Please note that, when gripping (pushing), the speed is fixed at 5 degrees/s.

\* The values in the graph below are gripping forces at 10mm gripping point. The actual gripping force decreases inversely proportional to the distance from the opening/closing point.  
You can calculate the actual gripping force by the following equation.  
Actual gripping force (type S)= $P \times 24 / (L + 14)$   
Actual gripping force (type M)= $P \times 28.5 / (L + 18.5)$   
P=Gripping force on graph  
L=Distance from finger mounting surface to the gripping point.

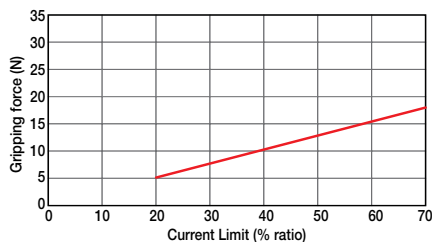

### Actuator Specifications

#### ■ Lead and Load Capacity

Model	Deceleration Ratio	Max. Gripping Force (N)	Stroke (deg)
RCP2-GR3LS-I-28P-30-19-①-②-③	30	18	19

Legend: ① Compatible controllers ② Cable length ③ Options

#### ■ Stroke and Maxi. Opening/Closing Speed

Deceleration Ratio	Stroke	19 (deg)
	30	200

(Unit: degrees/s)

#### ① Stroke List

Stroke (deg)	Standard Price
10	-

#### ② Cable List

Type	Cable Symbol	Standard Price
Standard Type	P (1m)	-
	S (3m)	-
	M (5m)	-
Special Lengths	X06 (6m) ~ X10 (10m)	-
	X11 (11m) ~ X15 (15m)	-
	X16 (16m) ~ X20 (20m)	-
Robot Cable	R01 (1m) ~ R03 (3m)	-
	R04 (4m) ~ R05 (5m)	-
	R06 (6m) ~ R10 (10m)	-
	R11 (11m) ~ R15 (15m)	-
	R16 (16m) ~ R20 (20m)	-

\* See page A-39 for cables for maintenance.

#### ③ Option List

Name	Option Code	See Page	Standard Price
Flange bracket	FB	→ A-26	-
Shaft bracket	SB	→ A-36	-

#### Actuator Specifications

Item	Description
Drive System	Worm gear + worm wheel gear
Positioning Repeatability	±0.01 degrees
Backlash	1 degree or less per side (constantly pressed out by a spring)
Lost Motion	0.15 degrees or less per side
Weight	0.6kg
Ambient Operating Temp./Humidity	0~40°C, 85% RH or less (non-condensing)

# 343

RCP2-GR3LS

Dimensions

CAD drawings can be downloaded from IAI website. [www.intelligentactuator.com](http://www.intelligentactuator.com)

For Special Orders P. A-9



- \* When homing, the actuator swings 1 degree past the home position before returning. Therefore, please watch for any interference with the surrounding objects.
- \*1 The motor-encoder cable is connected here. See page A-39 for details on cables.

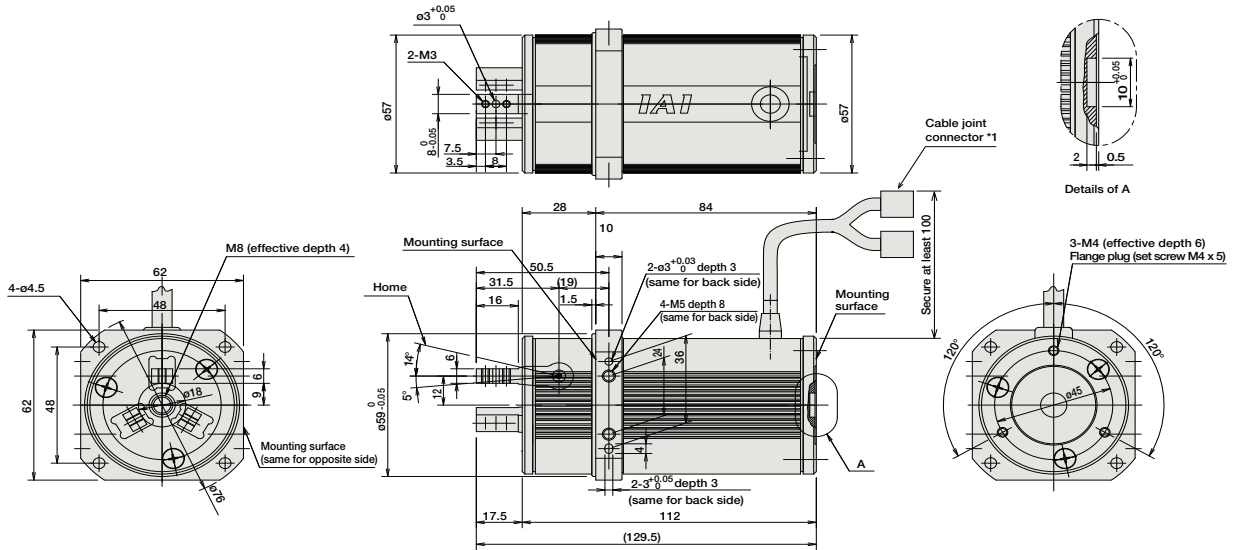

Weight (kg) 0.6

① Compatible Controllers

The RCP2 series actuators can operate with the controllers below. Select the controller according to your usage.

Name	External View	Model	Description	Max. Positioning Points	Input Voltage	Power Supply Capacity	Standard Price	See Page
Solenoid Valve Type		PMEC-C-28PI-NP-2-①	Easy-to-use controller, even for beginners	3 points	AC100V AC200V	See P481	-	→ P477
Splash-Proof Solenoid Valve Type		PSEP-C-28PI-NP-2-0 PSEP-CW-28PI-NP-2-0	Operable with same signal as solenoid valve. Supports both single and double solenoid types. No homing necessary with simple absolute type.					→ P487
Positioner Type		PCON-C-28PI-NP-2-0	Positioning is possible for up to 512 points	512 points	DC24V	2A max.	-	→ P525
Safety-Compliant Positioner Type		PCON-CG-28PI-NP-2-0						
Pulse Train Input Type (Differential Line Driver)		PCON-PL-28PI-NP-2-0	Pulse train input type with differential line driver support	(-)	DC24V	2A max.	-	→ P525
Pulse Train Input Type (Open Collector)		PCON-PO-28PI-NP-2-0	Pulse train input type with open collector support					
Serial Communication Type		PCON-SE-28PI-N-0-0	Dedicated to serial communication	64 points				
Field Network Type		RPCON-28P	Dedicated to field network	768 points				→ P503
Program Control Type		PSEL-C-1-28PI-NP-2-0	Programmed operation is possible Operation is possible on up to 2 axes	1500 points				→ P557

\* This is for the single-axis PSEL.  
\* ① is a placeholder for the power supply voltage (1: 100V, 2: 100~240V).



RCP2-GR3LS **344**

- Slider Type
- Mini
- Standard
- Controllers Integrated
- Rod Type
- Mini
- Standard
- Controllers Integrated
- Table/Arm /Flat Type
- Mini
- Standard
- Gripper/ Rotary Type
- Linear Servo Type
- Cleanroom Type
- Splash-Proof
- Controllers
- PMEC /AMEC
- PSEP /ASEP
- ROBO NET
- ERC2
- PCON
- ACON
- SCON
- PSEL
- ASEL
- SSEL
- XSEL
- Pulse Motor
- Servo Motor (24V)
- Servo Motor (200V)
- Linear Servo Motor

# RCP2-GR3LM

ROBO Cylinder 3-Finger Gripper Lever Type 80mm Width Pulse Motor

■ Configuration: **RCP2-GR3LM-I-42P-30-19**

Series — Type — Encoder — Motor — Deceleration Ratio — Stroke — Compatible Controllers — Cable Length — Option

I: Incremental  
\* The Simple absolute encoder is also considered type "I".

42P: 42 □ size Pulse motor  
30: 1/30 deceleration ratio  
19: 19 degrees

P1: PCON  
RPCON  
PSEL  
P3: PMEC  
PSEP

N: None  
P: 1m  
S: 3m  
M: 5m  
X □ □ : Custom  
R □ □ : Robot cable

FB: Flange bracket  
SB: Shaft bracket

\* See page Pre-35 for an explanation of the naming convention.



Technical References P. A-5

- POINT** Notes on Selection
- (1) The maximum opening/closing speed indicates the operating speed on one side. The relative operating speed is twice this value.
  - (2) The maximum gripping force is the sum of the gripping forces of all fingers with gripping point distance of 10mm and no overhang distance. For the actual transportable work piece weight, see explanation on the right, or page A-77.
  - (3) The rated acceleration while moving is 0.3G.

### ■ Gripping Force vs. Current Limit Lever Type (GR3LS/GR3LM)

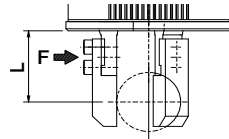

\* Please note that, when gripping (pushing), the speed is fixed at 5 degrees/s.

\* The values in the graph below are gripping forces at 10mm gripping point. The actual gripping force decreases inversely proportional to the distance from the opening/closing point. You can calculate the actual gripping force by the following equation.  
Actual gripping force (type S)= $P \times 24 / (L + 14)$   
Actual gripping force (type M)= $P \times 28.5 / (L + 18.5)$   
P=Gripping force on graph  
L=Distance from finger mounting surface to the gripping point.

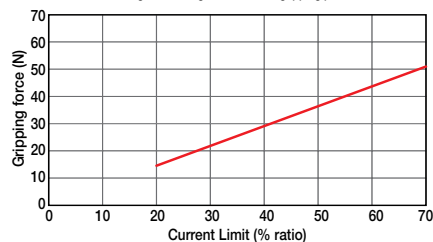

Actuator Specifications				Stroke and Maxi. Opening/Closing Speed	
■ Lead and Load Capacity				■ Stroke and Maxi. Opening/Closing Speed	
Model	Deceleration Ratio	Max. Gripping Force (N)	Stroke (deg)	Stroke Deceleration Ratio	19 (deg)
RCP2-GR3LM-I-42P-30-19-①-②-③	30	51	19	30	200
Legend: ① Compatible controllers ② Cable length ③ Options				(Unit: degrees/s)	

Stroke List	
Stroke (deg)	Standard Price
10	-

② Cable List		
Type	Cable Symbol	Standard Price
Standard Type	P (1m)	-
	S (3m)	-
	M (5m)	-
Special Lengths	X06 (6m) ~ X10 (10m)	-
	X11 (11m) ~ X15 (15m)	-
	X16 (16m) ~ X20 (20m)	-
Robot Cable	R01 (1m) ~ R03 (3m)	-
	R04 (4m) ~ R05 (5m)	-
	R06 (6m) ~ R10 (10m)	-
	R11 (11m) ~ R15 (15m)	-
	R16 (16m) ~ R20 (20m)	-

\* See page A-39 for cables for maintenance.

③ Option List			
Name	Option Code	See Page	Standard Price
Flange bracket	FB	→ A-26	-
Shaft bracket	SB	→ A-36	-

Actuator Specifications	
Item	Description
Drive System	Worm gear + worm wheel gear
Positioning Repeatability	±0.01 degrees
Backlash	1 degree or less per side (constantly pressed out by a spring)
Lost Motion	0.15 degrees or less per side
Weight	1.1 kg
Ambient Operating Temp./Humidity	0~40°C, 85% RH or less (non-condensing)

# 345

RCP2-GR3LM



Dimensions

CAD drawings can be downloaded from IAI website. [www.intelligentactuator.com](http://www.intelligentactuator.com)



- \* When homing, the actuator swings 1 degree past the home position before returning. Therefore, please watch for any interference with the surrounding objects.
- \*1 The motor-encoder cable is connected here. See page A-39 for details on cables.

For Special Orders P. A-9

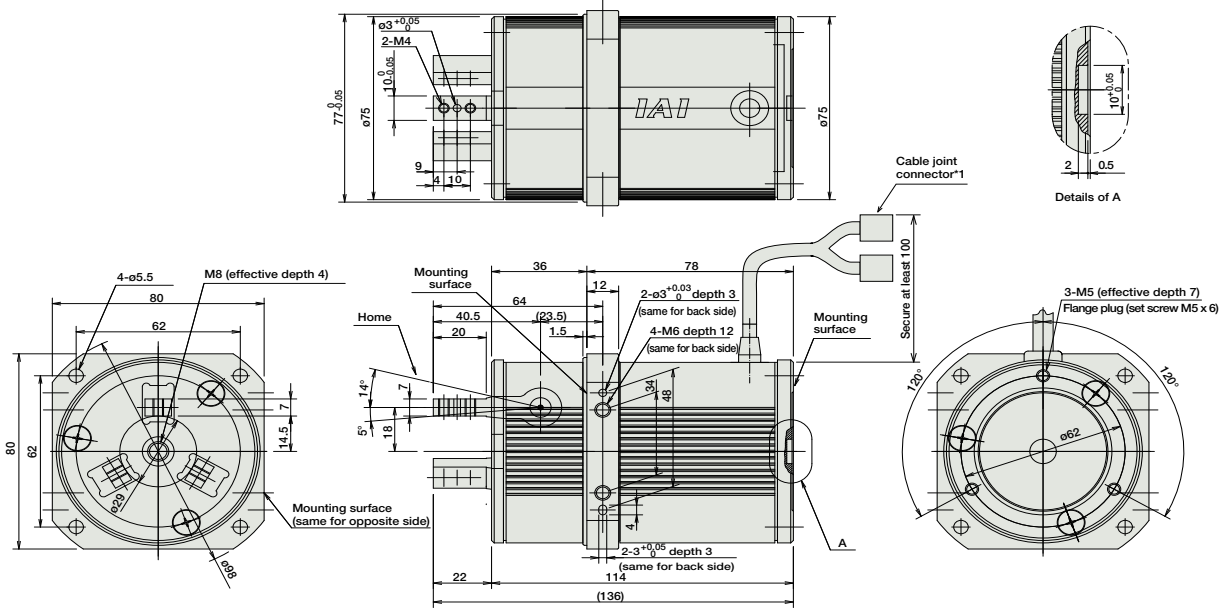

Weight (kg) 1.1

① Compatible Controllers

The RCP2 series actuators can operate with the controllers below. Select the controller according to your usage.

Name	External View	Model	Description	Max. Positioning Points	Input Voltage	Power Supply Capacity	Standard Price	See Page
Solenoid Valve Type		PMEC-C-42PI-NP-2-①	Easy-to-use controller, even for beginners	3 points	AC100V AC200V	See P481	-	→ P477
Splash-Proof Solenoid Valve Type		PSEP-C-42PI-NP-2-0	Operable with same signal as solenoid valve. Supports both single and double solenoid types. No homing necessary with simple absolute type.					→ P487
Positioner Type		PCON-C-42PI-NP-2-0	Positioning is possible for up to 512 points	512 points	DC24V	2A max.	-	→ P525
Safety-Compliant Positioner Type		PCON-CG-42PI-NP-2-0						
Pulse Train Input Type (Differential Line Driver)		PCON-PL-42PI-NP-2-0	Pulse train input type with differential line driver support	(-)	DC24V	2A max.	-	→ P525
Pulse Train Input Type (Open Collector)		PCON-PO-42PI-NP-2-0	Pulse train input type with open collector support					
Serial Communication Type		PCON-SE-42PI-N-0-0	Dedicated to serial communication	64 points				
Field Network Type		RPCON-42P	Dedicated to field network	768 points				→ P503
Program Control Type		PSEL-C-1-42PI-NP-2-0	Programmed operation is possible. Operation is possible on up to 2 axes	1500 points				→ P557

\* This is for the single-axis PSEL.  
 \* ① is a placeholder for the power supply voltage (1: 100V, 2: 100~240V).



RCP2-GR3LM **346**

- Slider Type
- Mini
- Standard
- Controllers Integrated
- Rod Type
- Mini
- Standard
- Controllers Integrated
- Table/Arm /Flat Type
- Mini
- Standard
- Gripper/ Rotary Type
- Linear Servo Type
- Cleanroom Type
- Splash-Proof
- Controllers
- PMEC /AMEC
- PSEP /ASEP
- ROBO NET
- ERC2
- PCON
- ACON
- SCON
- PSEL
- ASEL
- SSEL
- XSEL
- Pulse Motor
- Servo Motor (24V)
- Servo Motor (200V)
- Linear Servo Motor



# RCP2-GR3SS

ROBO Cylinder 3-Finger Gripper Slider Type 62mm Width Pulse Motor

■ Configuration: **RCP2-GR3SS-I-28P-30-10**

Series — Type — Encoder — Motor — Deceleration Ratio — Stroke — Compatible Controllers — Cable Length — Option

I: Incremental  
\* The Simple absolute encoder is also considered type "I".

28P: 28 □ size Pulse motor

30: 1/30 deceleration (5mm per side) ratio

10: 10mm

P1: PCON  
RPCON  
PSEL  
P3: PMEC  
PSEP

N: None  
P: 1m  
S: 3m  
M: 5m  
X □ □ : Custom  
R □ □ : Robot cable

FB: Flange bracket  
SB: Shaft bracket

\* See page Pre-35 for an explanation of the naming convention.



Technical References P. A-5

- POINT** Notes on Selection
- (1) The maximum opening/closing speed indicates the operating speed on one side. The relative operating speed is twice this value.
  - (2) The maximum gripping force is the sum of the gripping forces of all fingers with gripping point distance of 10mm and no overhang distance. For the actual transportable work piece weight, see explanation on the right or page A-74.
  - (3) The rated acceleration while moving is 0.3G.

■ Gripping Force vs. Current Limit  
Slider Type (GR3SS/GR3SM)

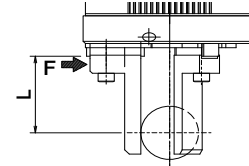

\* Please keep the distance L from the finger mounting surface to the gripping point at less than the following dimensions.

GR3SS → 50mm or less  
GR3SM → 80mm or less

\* Please note that, when gripping (pushing), the speed is fixed at 5mm/s.

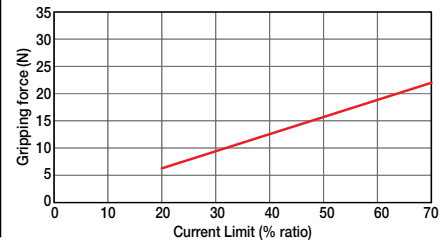

Actuator Specifications				Stroke and Maxi. Opening/Closing Speed	
■ Lead and Load Capacity				■ Stroke and Maxi. Opening/Closing Speed	
Model	Deceleration Ratio	Max. Gripping Force (N)	Stroke (mm)	Stroke / Deceleration Ratio	10 (mm)
RCP2-GR3SS-I-28P-30-10-①-②-③	30	22	10	30	40

Legend: ① Compatible controllers ② Cable length ③ Options (Unit: mm/s)

Stroke List	
Stroke (mm)	Standard Price
10	-

② Cable List		
Type	Cable Symbol	Standard Price
Standard Type	P (1m)	-
	S (3m)	-
	M (5m)	-
Special Lengths	X06 (6m) ~ X10 (10m)	-
	X11 (11m) ~ X15 (15m)	-
	X16 (16m) ~ X20 (20m)	-
Robot Cable	R01 (1m) ~ R03 (3m)	-
	R04 (4m) ~ R05 (5m)	-
	R06 (6m) ~ R10 (10m)	-
	R11 (11m) ~ R15 (15m)	-
	R16 (16m) ~ R20 (20m)	-

\* See page A-39 for cables for maintenance.

③ Option List			
Name	Option Code	See Page	Standard Price
Flange bracket	FB	→ A-26	-
Shaft bracket	SB	→ A-36	-

Actuator Specifications	
Item	Description
Drive System	Worm gear + worm wheel gear
Positioning Repeatability	±0.01mm
Backlash	0.3mm or less per side (constantly pressed out by a spring)
Lost Motion	0.1mm or less per side
Guide	Cross roller guide
Allowable Static Load Moment	Ma: 3.8 N·m Mb: 3.8 N·m Mc: 3.0 N·m
Weight	0.6kg
Ambient Operating Temp./Humidity	0~40°C, 85% RH or less (non-condensing)

# 347

RCP2-GR3SS

Dimensions

CAD drawings can be downloaded from IAI website. [www.intelligentactuator.com](http://www.intelligentactuator.com)

For Special Orders P. A-9



- \* When homing, the actuator swings 0.5mm past the home position before returning. Therefore, please watch for any interference with the surrounding objects.
- \*1 The motor-encoder cable is connected here. See page A-39 for details on cables.

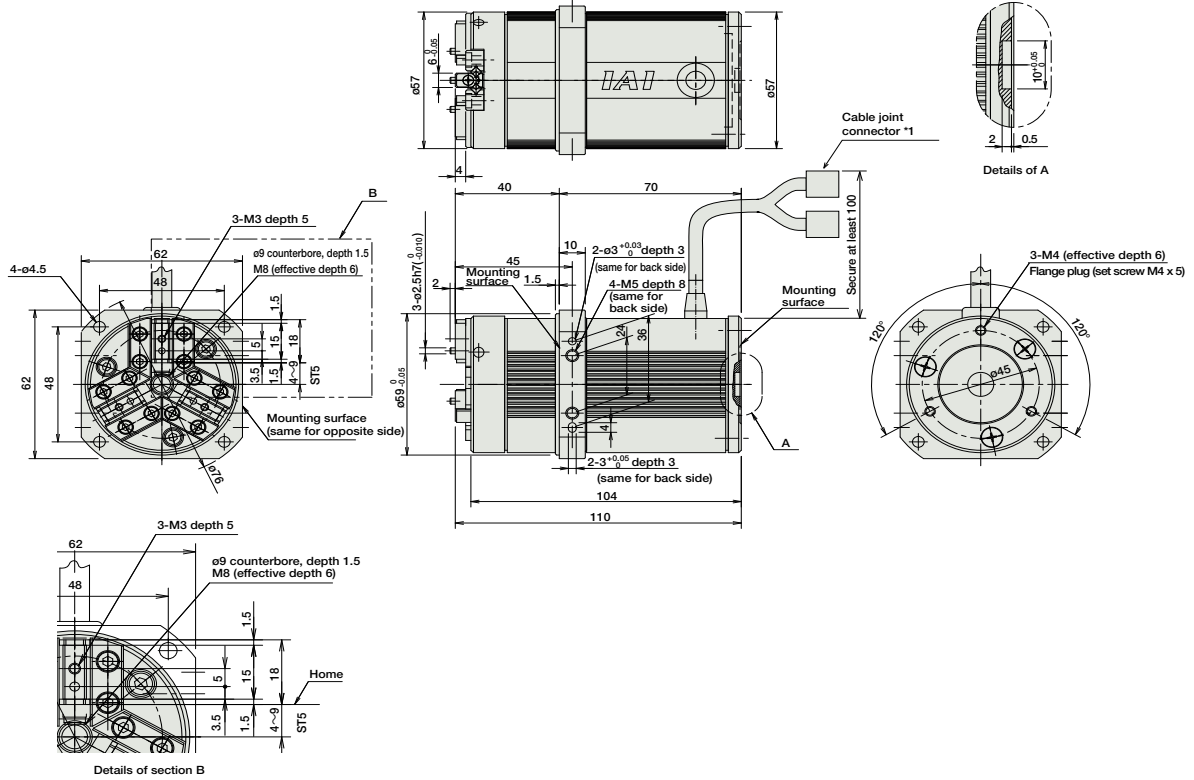

Weight (kg) 0.6

① Compatible Controllers

The RCP2 series actuators can operate with the controllers below. Select the controller according to your usage.

Name	External View	Model	Description	Max. Positioning Points	Input Voltage	Power Supply Capacity	Standard Price	See Page
Solenoid Valve Type		PMEC-C-28PI-NP-2-①	Easy-to-use controller, even for beginners	3 points	AC100V AC200V	See P481	-	→ P477
		PSEP-C-28PI-NP-2-0	Operable with same signal as solenoid valve. Supports both single and double solenoid types. No homing necessary with simple absolute type.				-	→ P487
Splash-Proof Solenoid Valve Type		PSEP-CW-28PI-NP-2-0					-	
Positioner Type		PCON-C-28PI-NP-2-0	Positioning is possible for up to 512 points	512 points			-	
Safety-Compliant Positioner Type		PCON-CG-28PI-NP-2-0					-	
Pulse Train Input Type (Differential Line Driver)		PCON-PL-28PI-NP-2-0	Pulse train input type with differential line driver support	(-)	DC24V	2A max.	-	→ P525
Pulse Train Input Type (Open Collector)		PCON-PO-28PI-NP-2-0	Pulse train input type with open collector support				-	
Serial Communication Type		PCON-SE-28PI-N-0-0	Dedicated to serial communication	64 points			-	
Field Network Type		RPCON-28P	Dedicated to field network	768 points			-	→ P503
Program Control Type		PSEL-C-1-28PI-NP-2-0	Programmed operation is possible Operation is possible on up to 2 axes	1500 points			-	→ P557

\* This is for the single-axis PSEL.  
 \* ① is a placeholder for the power supply voltage (1: 100V, 2: 100~240V).



RCP2-GR3SS **348**

- Slider Type
- Mini
- Standard
- Controllers Integrated
- Rod Type
- Mini
- Standard
- Controllers Integrated
- Table/Arm /Flat Type
- Mini
- Standard
- Gripper/ Rotary Type
- Linear Servo Type
- Cleanroom Type
- Splash-Proof
- Controllers
- PMEC /AMEC
- PSEP /ASEP
- ROBO NET
- ERC2
- PCON
- ACON
- SCON
- PSEL
- ASEL
- SSEL
- XSEL
- Pulse Motor
- Servo Motor (24V)
- Servo Motor (200V)
- Linear Servo Motor

# RCP2-GR3SM

ROBO Cylinder 3-Finger Gripper Slider Type 80mm Width Pulse Motor

■ Configuration: **RCP2-GR3SM-I-42P-30-14** —  —  —

Series — Type — Encoder — Motor — Deceleration Ratio — Stroke — Compatible Controllers — Cable Length — Option

I: Incremental  
\* The Simple absolute encoder is also considered type "I".

42P: 42 □ size Pulse motor  
30: 1/30 deceleration ratio (7mm per side)  
14: 14mm stroke (7mm per side)

P1: PCON  
RPCON  
PSEL  
P3: PMEC  
PSEP

N: None  
P: 1m  
S: 3m  
M: 5m  
X□□: Custom  
R□□: Robot cable

FB: Flange bracket  
SB: Shaft bracket

\* See page Pre-35 for an explanation of the naming convention.



Technical References P. A-5



- (1) The maximum opening/closing speed indicates the operating speed on one side. The relative operating speed is twice this value.
- (2) The maximum gripping force is the sum of the gripping forces of all fingers with gripping point distance of 10mm and no overhang distance. For the actual transportable work piece weight, see explanation on the right or page A-74.
- (3) The rated acceleration while moving is 0.3G.

### ■ Gripping Force vs. Current Limit Slider Type (GR3SS/GR3SM)

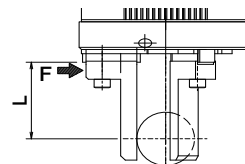

\* Please keep the distance L from the finger mounting surface to the gripping point at less than the following dimensions.

GR3SS → 50mm or less  
GR3SM → 80mm or less

\* Please note that, when gripping (pushing), the speed is fixed at 5mm/s.

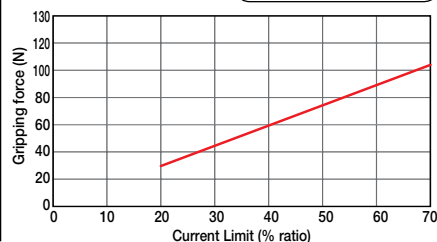

### Actuator Specifications

#### ■ Lead and Load Capacity

Model	Deceleration Ratio	Max. Gripping Force (N)	Stroke (mm)
RCP2-GR3SM-I-42P-30-14-①-②-③	30	102	14

Legend: ① Compatible controllers ② Cable length ③ Options

#### ■ Stroke and Maxi. Opening/Closing Speed

Deceleration Ratio	Stroke	14 (mm)
	30	50

(Unit: mm/s)

#### ① Stroke List

Stroke (mm)	Standard Price
14	-

#### ② Cable List

Type	Cable Symbol	Standard Price
Standard Type	P (1m)	-
	S (3m)	-
	M (5m)	-
Special Lengths	X06 (6m) ~ X10 (10m)	-
	X11 (11m) ~ X15 (15m)	-
	X16 (16m) ~ X20 (20m)	-
	R01 (1m) ~ R03 (3m)	-
Robot Cable	R04 (4m) ~ R05 (5m)	-
	R06 (6m) ~ R10 (10m)	-
	R11 (11m) ~ R15 (15m)	-
	R16 (16m) ~ R20 (20m)	-

\* See page A-39 for cables for maintenance.

#### ③ Option List

Name	Option Code	See Page	Standard Price
Flange bracket	FB	→ A-26	-
Shaft bracket	SB	→ A-36	-

#### Actuator Specifications

Item	Description
Drive System	Worm gear + worm wheel gear
Positioning Repeatability	±0.01mm
Backlash	0.3mm or less per side (constantly pressed out by a spring)
Lost Motion	0.1mm or less per side
Guide	Cross roller guide
Allowable Static Load Moment	Ma: 6.3 N·m Mb: 6.3 N·m Mc: 5.7 N·m
Weight	1.2kg
Ambient Operating Temp./Humidity	0~40°C, 85% RH or less (non-condensing)

# 349

RCP2-GR3SM

Dimensions

CAD drawings can be downloaded from IAI website. [www.intelligentactuator.com](http://www.intelligentactuator.com)



- \* When homing, the actuator swings 0.5mm past the home position before returning. Therefore, please watch for any interference with the surrounding objects.
- \*1 The motor-encoder cable is connected here. See page A-39 for details on cables.

For Special Orders P. A-9

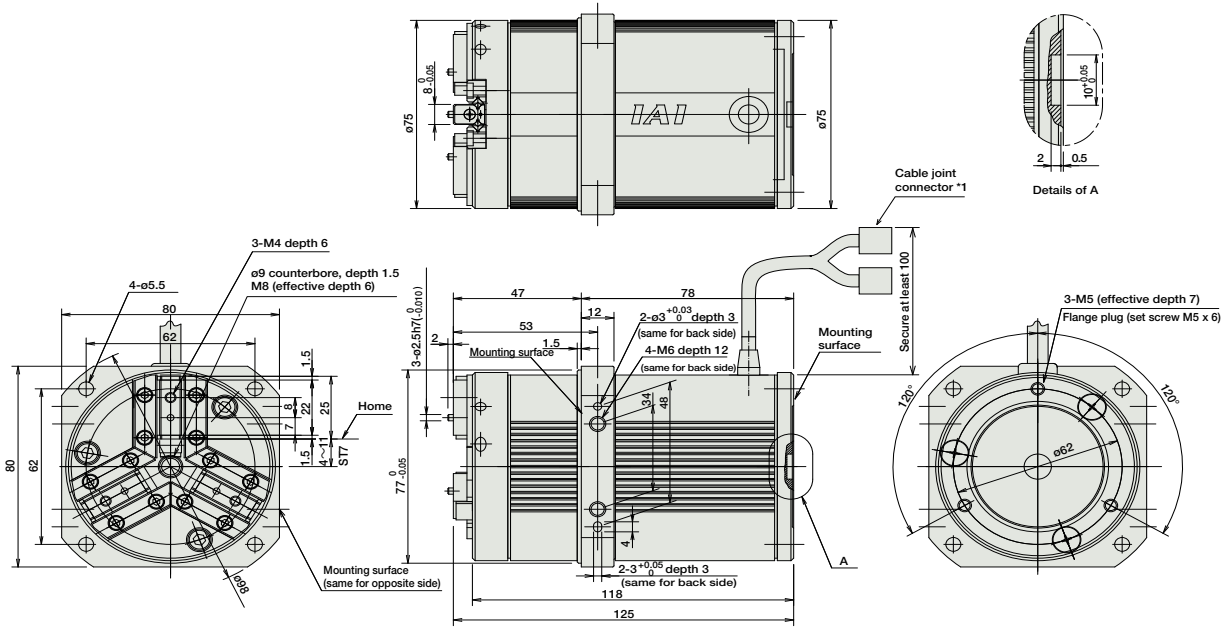

Weight (kg) 1.2

① Compatible Controllers

The RCP2 series actuators can operate with the controllers below. Select the controller according to your usage.

Name	External View	Model	Description	Max. Positioning Points	Input Voltage	Power Supply Capacity	Standard Price	See Page
Solenoid Valve Type		PMEC-C-42PI-NP-2-①	Easy-to-use controller, even for beginners	3 points	AC100V AC200V	See P481	-	→ P477
Splash-Proof Solenoid Valve Type		PSEP-C-42PI-NP-2-0 PSEP-CW-42PI-NP-2-0	Operable with same signal as solenoid valve. Supports both single and double solenoid types. No homing necessary with simple absolute type.					→ P487
Positioner Type		PCON-C-42PI-NP-2-0	Positioning is possible for up to 512 points	512 points	DC24V	2A max.	-	→ P525
Safety-Compliant Positioner Type		PCON-CG-42PI-NP-2-0						
Pulse Train Input Type (Differential Line Driver)		PCON-PL-42PI-NP-2-0	Pulse train input type with differential line driver support	(-)	DC24V	2A max.	-	→ P525
Pulse Train Input Type (Open Collector)		PCON-PO-42PI-NP-2-0	Pulse train input type with open collector support					
Serial Communication Type		PCON-SE-42PI-N-0-0	Dedicated to serial communication	64 points	DC24V	2A max.	-	-
Field Network Type		RPCON-42P	Dedicated to field network	788 points	DC24V	2A max.	-	→ P503
Program Control Type		PSEL-C-1-42PI-NP-2-0	Programmed operation is possible. Operation is possible on up to 2 axes.	1500 points	DC24V	2A max.	-	→ P557

\* This is for the single-axis PSEL.  
 \* ① is a placeholder for the power supply voltage (1: 100V, 2: 100~240V).



RCP2-GR3SM **350**

- Slider Type
- Mini
- Standard
- Controllers Integrated
- Rod Type
- Mini
- Standard
- Controllers Integrated
- Table/Arm /Flat Type
- Mini
- Standard
- Gripper/ Rotary Type
- Linear Servo Type
- Cleanroom Type
- Splash-Proof
- Controllers
- PMEC /AMEC
- PSEP /ASEP
- ROBO NET
- ERC2
- PCON
- ACON
- SCON
- PSEL
- ASEL
- SSEL
- XSEL
- Pulse Motor
- Servo Motor (24V)
- Servo Motor (200V)
- Linear Servo Motor

# RCS2-GR8

ROBO Cylinder 2-Finger Gripper Long Stroke Slider Type 104 ~ 284mm Width  
200V Servo Motor

■ Configuration: **RCS2** — **GR8** — **I** — **60** — **5** —  —  —

Series — Type — Encoder — Motor — Deceleration Ratio — Stroke — Compatible Controllers — Cable Length

I : Incremental 60: 60W Servo motor 5 : 1/5

Stroke: 20: 20mm, 40: 40mm, (60): 60mm, (80): 80mm, 100: 100mm, (120): 120mm, (200): 200mm

Compatible Controllers: T1 : XSEL-J/K, T2 : SCON, SSEL, XSEL-P/Q

Cable Length: N : None, P : 1m, S : 3m, M : 5m, X  : Custom Length, R  : Robot Cable

\* See page Pre-35 for explanation of each code that makes up the configuration name.

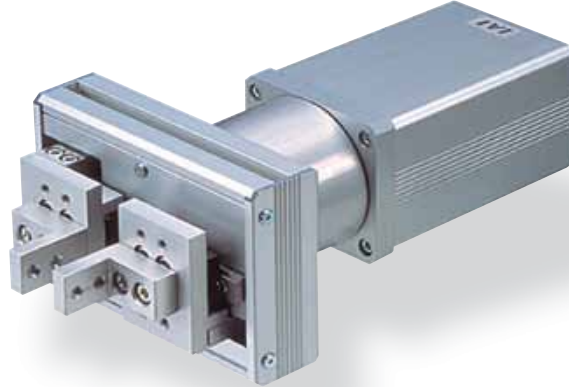

\* Please note that, when gripping (pressing), the speed is fixed at 10mm/s.

Technical References P. A-5

**4 POINT**  
Notes on Selection

(1) Stroke values enclosed in "( )" are (60, 80, 120, 200) are semi-standard models.  
(2) The maximum gripping force is the sum of both fingers.

**Actuator Specifications**

■ Lead and Load Capacity

Model	Motor Output (W)	Deceleration Ratio	Max. Gripping Force (N)	Stroke (mm)
RCS2-GR8-I-60-5-①-②-③	60	1/5	45.1	20, 40, (60), (80), 100, (120), (200)

Legend: ① Stroke ② Compatible controller ③ Cable length

① Stroke List

Stroke (mm)	Standard Price
20	-
40	-
(60)	-
(80)	-
100	-
(120)	-
(200)	-

③ Cable List

Type	② Cable Symbol	Standard Price
Standard Type	P (1m)	-
	S (3m)	-
	M (5m)	-
Special Lengths	X06 (6m) ~ X10 (10m)	-
	X11 (11m) ~ X15 (15m)	-
	X16 (16m) ~ X20 (20m)	-
	R01 (1m) ~ R03 (3m)	-
Robot Cable	R04 (4m) ~ R05 (5m)	-
	R06 (6m) ~ R10 (10m)	-
	R11 (11m) ~ R15 (15m)	-
	R16 (16m) ~ R20 (20m)	-

\* See page A-39 for cables for maintenance.

**Actuator Specifications**

Item	Description
Drive System	Rack and pinion
Positioning Repeatability	±0.04mm
Lost Motion	0.7mm or less
Base	Material: Aluminum (white alumite treated)
Allowable Static Load Moment	Ma: 5.1 N-m Mb: 5.1 N-m Mc: 10.4 N-m
Ambient Operating Temp./Humidity	0 ~ 40°C, 85% RH or less (non-condensing)

# 351

RCS2-GR8

- Slider Type
- Mini
- Standard
- Controllers Integrated
- Rod Type
- Mini
- Standard
- Controllers Integrated
- Table/Arm/Flat Type
- Mini
- Standard
- Gripper/Rotary Type
- Linear Servo Type
- Cleanroom Type
- Splash-Proof
- Controllers
- PMEC/AMEC
- PSEP/ASEP
- ROBO NET
- ERC2
- PCON
- ACON
- SCON
- PSEL
- ASEL
- SSEL
- XSEL
- Pulse Motor
- Servo Motor (24V)
- Servo Motor (200V)
- Linear Servo Motor

Dimensions

CAD drawings can be downloaded from IAI website. [www.intelligentactuator.com](http://www.intelligentactuator.com)

For Special Orders P. A-9



\* The opening side of the slider is the home position.

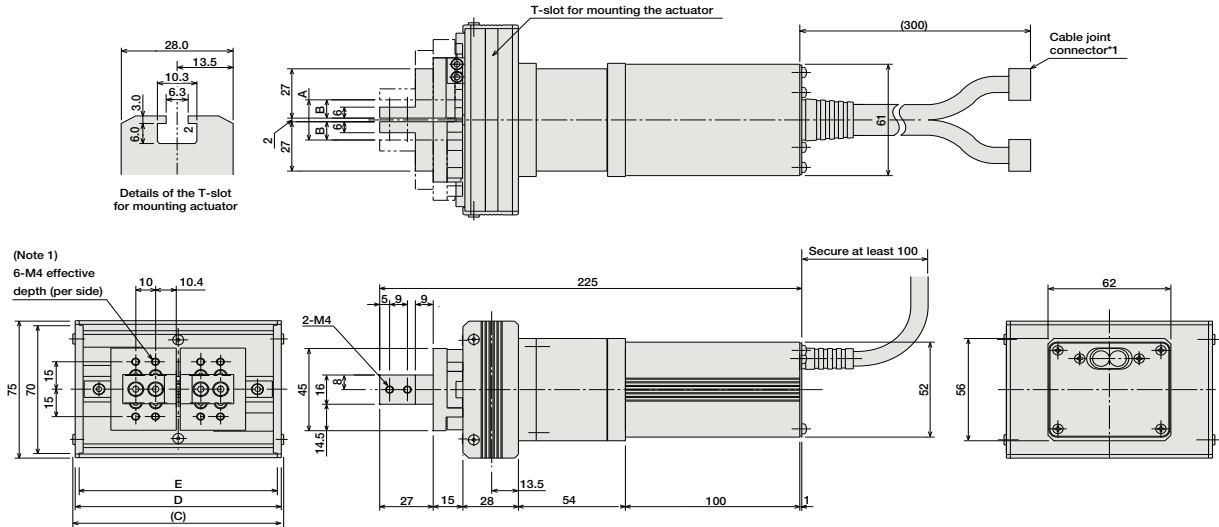

\*1 The motor cable and encoder cable are connected here. See page A-39 for details on cables. (Note 1) The number of tapped holes on the finger mounting plate is for one side. In addition, by default, each finger is secured using 2 tapped holes.

Dimensions and Weight by Stroke

Stroke	20	40	(60)	(80)	100	(120)	(200)
A	22	42	62	82	102	122	202
B	10	20	30	40	50	60	100
C	106.4	126.4	146.4	166.4	186.4	206.4	286.4
D	104	124	144	164	184	204	284
E	100	120	140	160	180	200	280
Weight (kg)	1.8	1.9	1.9	2.0	2.0	2.1	2.3

\*1 The strokes enclosed in "()" are semi-standard configurations, and will require longer delivery time.

Compatible controller

The RCS2 series actuators can operate with the controllers below. Select the controller according to your usage.

Name	External View	Model	Description	Max. Positioning Points	Input Voltage	Power Supply Capacity	Standard Price	See Page
Positioner Mode		SCON-C-60-NP-2-①	Positioning is possible for up to 512 points	512 points	Single-phase AC100V Single-phase AC200V Three-phase AC200V (XSEL-P/Q only)	360VA max.  * When operating a 150W single-axis model	-	→ P547
Solenoid Valve Mode			Operable with the same controls as the solenoid valve	7 points				
Serial Communication Type			Dedicated to serial communication	64 points				
Pulse Train Input Control Type			Dedicated to pulse train input	(-)				
Program Control 1 - 2 Axes Type		SSEL-C-1-60-NP-2-①	Programmed operation is possible Operation is possible on up to 2 axes	1500 points			-	→ P577
Program Control 1-6 Axis Type		XSEL-②-1-60-N1-EEE-2-③	Programmed operation is possible Operation is possible on up to 6 axes	20000 points			-	→ P587

\* For SSEL and XSEL, only applicable to the single-axis model.  
 \* ① is a placeholder for the power supply voltage (1: 100V, or 2: single-phase 200V).  
 \* ② is a placeholder for the type name of XSEL ("J", "K", "P", "Q").  
 \* ③ is a placeholder for the type of power supply voltage (1: 100V, 2: single-phase 200V, or 3: 3-phase 200V).

- Slider Type
- Mini
- Standard
- Controllers Integrated
- Rod Type
- Mini
- Standard
- Controllers Integrated
- Table/Arm /Flat Type
- Mini
- Standard
- Gripper/ Rotary Type
- Linear Servo Type
- Cleanroom Type
- Splash-Proof
- Controllers
- PMEC /AMEC
- PSEP /ASEP
- ROBO NET
- ERC2
- PCON
- ACON
- SCON
- PSEL
- ASEL
- SSEL
- XSEL
- Pulse Motor
- Servo Motor (24V)
- Servo Motor (200V)
- Linear Servo Motor

# RCP2-RTBS/RTBSL

ROBO Cylinder Rotary Small Vertical Type 45mm Width Pulse Motor

■ Configuration: **RCP2** —  — **I** — **20P** —  —  —  —  —

Series — Type — Encoder — Motor — Deceleration Ratio — Oscillation Angle — Compatible Controllers — Cable Length — Option

RTBS: 330-degree rotation  
RTBSL: Multiple rotation

I: Incremental  
\* The Simple absolute encoder is also considered type "I".

20P: 20 □ size Pulse motor

30: 1/30 deceleration ratio  
45: 1/45 deceleration ratio

330: 330degrees (RTBS only)  
360: 360degrees (RTBSL only)

P1: PCON  
RPCON  
PSEL  
P3: PMEC  
PSEP

N: None  
P: 1m  
S: 3m  
M: 5m  
X □ □ : Custom  
R □ □ : Robot cable

NM: Reversed-rotation  
SA: Shaft adapter  
TA: Table adapter

\* See page Pre-35 for an explanation of the naming convention.



Technical References P. A-5

- POINT** Notes on Selection
- (1) The output torque decreases as the rotational speed increases. Check the output torque graph on the right to see whether the speed required for your desired motion is supported.
  - (2) The allowable moment of inertia of the rotated work piece varies with the rotational speed. Check the Allowable Moment of Inertia graph on the right to see if the moment of inertia required for your desired motion is within the allowable range.
  - (3) The rated acceleration while moving is 0.2G.

■ Speed vs. Load Capacity  
Due to the characteristics of the Pulse Motor, the RCP2 series' load capacity decreases at high speeds. In the table below, check if your desired speed and load capacity are supported.

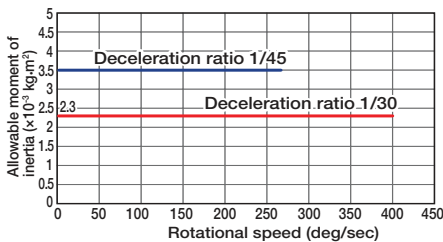
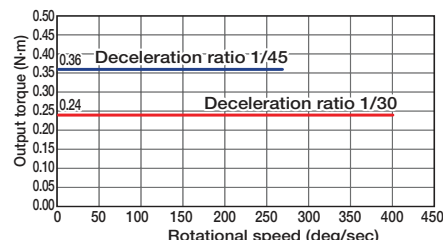

## Actuator Specifications

■ Lead and Load Capacity

Model	Deceleration Ratio	Max. Torque (N·m)	Allowable Moment of Inertia (kg·m²)	Oscillation Angle (deg)
RCP2-RTBS-I-20P-30-330-①-②-③	1/30	0.24	0.0023	330
RCP2-RTBS-I-20P-45-330-①-②-③	1/45	0.36	0.0035	
RCP2-RTBSL-I-20P-30-360-①-②-③	1/30	0.24	0.0023	360
RCP2-RTBSL-I-20P-45-360-①-②-③	1/45	0.36	0.0035	

■ Deceleration Ratio and Max. Speed

Stroke / Deceleration Ratio	330/360 (deg)
1/30	400
1/45	266

(Unit: degrees/s)

Legend: ① Compatible controller ② Cable length ③ Options

### Stroke List

Type	Oscillation Angle (deg)	Standard Price
RTBS	330	-
RTBSL	360	-

### ② Cable List

Type	Cable Symbol	Standard Price
Standard Type (Robot Cables)	P (1m)	-
	S (3m)	-
	M (5m)	-
Special Lengths	X06 (6m) ~ X10 (10m)	-
	X11 (11m) ~ X15 (15m)	-
	X16 (16m) ~ X20 (20m)	-
		-

\* The standard cable is the motor-encoder integrated robot cable.  
\* See page A-39 for cables for maintenance.

### ③ Option List

Name	Option Code	See Page	Standard Price
Reversed-rotation (*)	NM	→ A-33	-
Shaft adapter	SA	→ A-35	-
Table adapter	TA	→ A-37	-

\* Reversed-rotation option can be selected on the multi-rotational model only.

### Actuator Specifications

Item	Description
Drive System	Hypoid gear
Positioning Repeatability	±0.05 degrees
Homing Accuracy	±0.05 degrees
Lost Motion	±0.1 degrees
Allowable Thrust Load	30N
Allowable Load Moment	3.6N·m
Weight	0.52kg
Ambient Operating Temp./Humidity	0 ~ 40°C, 85% RH or less (non-condensing)

# 353

RCP2-RTBS/RTBSL



Dimensions

CAD drawings can be downloaded from IAI website. [www.intelligentactuator.com](http://www.intelligentactuator.com)

For Special Orders P. A-9

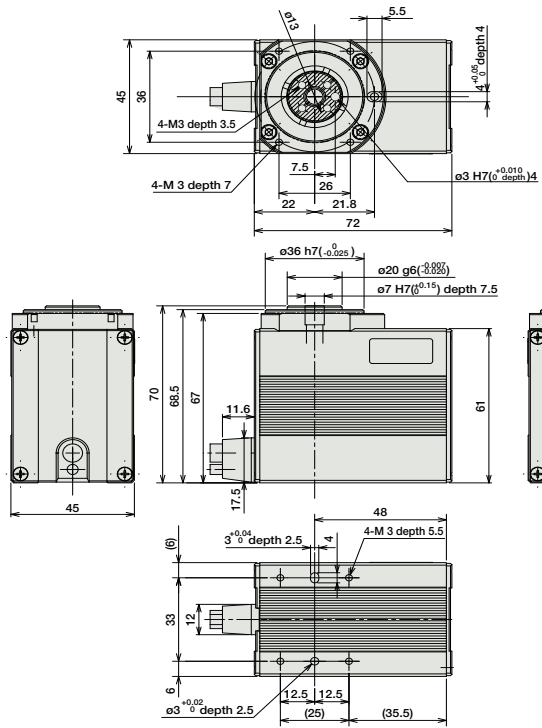

Note:  
\* In the 2D drawing on the left, the shaded area indicates the rotating part.

\*1 The motor-encoder cable is connected here. See page A-39 for details on cables.

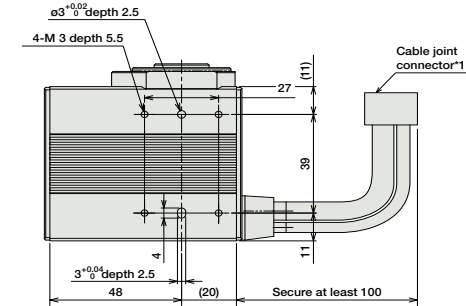

Note:  
The position in the 2D drawing on the left is the home position. When homing, the actuator rotates to the left past the home position by 1 degree. Therefore please watch for any interference with the surrounding objects. The range of motion is 330 degrees clockwise, as viewed from above.

Weight (kg) 0.52

① Compatible Controllers

The RCP2 series actuators can operate with the controllers below. Select the controller according to your usage.

Name	External View	Model	Description	Max. Positioning Points	Input Voltage	Power Supply Capacity	Standard Price	See Page
Solenoid Valve Type		PMEC-C-20PI-NP-2-①	Easy-to-use controller, even for beginners	3 points	AC100V AC200V	See P481	-	→ P477
		PSEP-C-20PI-NP-2-0	Operable with same signal as solenoid valve. Supports both single and double solenoid types. No homing necessary with simple absolute type.					→ P487
Splash-Proof Solenoid Valve Type		PSEP-CW-20PI-NP-2-0						
Positioner Type		PCON-C-20PI-NP-2-0	Positioning is possible for up to 512 points	512 points	DC24V	2A max.	-	
Safety-Compliant Positioner Type		PCON-CG-20PI-NP-2-0						
Pulse Train Input Type (Differential Line Driver)		PCON-PL-20PI-NP-2-0	Pulse train input type with differential line driver support	(-)	DC24V	2A max.	-	→ P525
Pulse Train Input Type (Open Collector)		PCON-PO-20PI-NP-2-0	Pulse train input type with open collector support					
Serial Communication Type		PCON-SE-20PI-N-0-0	Dedicated to serial communication	64 points				
Field Network Type		RPCON-20P	Dedicated to field network	768 points				→ P503
Program Control Type		PSEL-C-1-20PI-NP-2-0	Programmed operation is possible. Operation is possible on up to 2 axes	1500 points				→ P557

\* This is for the single-axis PSEL.  
\* ① is a placeholder for the power supply voltage (1: 100V, 2: 100~240V).

- Slider Type
- Mini
- Standard
- Controllers Integrated
- Rod Type
- Mini
- Standard
- Controllers Integrated
- Table/Arm /Flat Type
- Mini
- Standard
- Cripper/ Rotary Type
- Linear Servo Type
- Cleanroom Type
- Splash-Proof
- Controllers
- PMEC /AMEC
- PSEP /ASEP
- ROBO NET
- ERC2
- PCON
- ACON
- SCON
- PSEL
- ASEL
- SSEL
- XSEL
- Pulse Motor
- Servo Motor (24V)
- Servo Motor (200V)
- Linear Servo Motor



RCP2-RTBS/RTBSL **354**



# RCP2-RTCS/RTCSL ROBO Cylinder Rotary Small Flat Type 72mm Width Pulse Motor

■ Configuration: **RCP2** —  — **I** — **20P** —  —  —  —  —

Series — Type — Encoder — Motor — Deceleration Ratio — Oscillation Angle — Compatible Controllers — Cable Length — Option

RTCS : 330 degree rotation  
 RTCSL : Multi-rotational

I: Incremental absolute encoder is also considered type "I".  
 \* The Simple absolute encoder is also considered type "I".

28P : 28 □ size Pulse motor  
 30: 1/30 deceleration ratio  
 45: 1/45 deceleration ratio

330: 330degrees (RTCS only)  
 360: 360degrees (RTCSL only)

P1: PCON  
 RPCON  
 PSEL  
 P3: PMEC  
 PSEP

N : None  
 P : 1m  
 S : 3m  
 M : 5m  
 X  : Custom  
 R  : Robot cable

NM : Reversed-rotation  
 SA : Shaft adapter  
 TA : Table adapter

\* See page Pre-35 for an explanation of the naming convention.

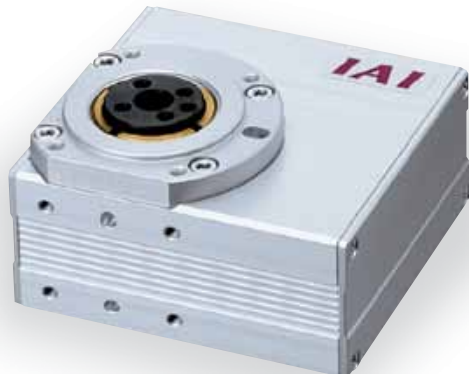

Technical References P. A-5

- POINT** Notes on Selection
- (1) The output torque decreases as the rotational speed increases. Check the output torque graph on the right to see whether the speed required for your desired motion is supported.
  - (2) The allowable moment of inertia of the rotated work piece varies with the rotational speed. Check the Allowable Moment of Inertia graph on the right to see if the moment of inertia required for your desired motion is within the allowable range.
  - (3) The rated acceleration while moving is 0.2G.

■ Speed vs. Load Capacity  
 Due to the characteristics of the Pulse motor, the RCP2 series' load capacity decreases at high speeds. In the table below, check if your desired speed and load capacity are supported.

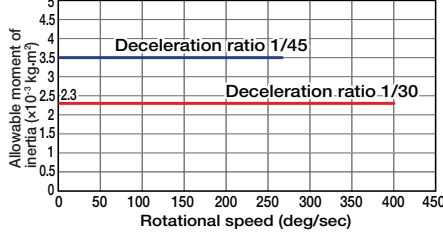
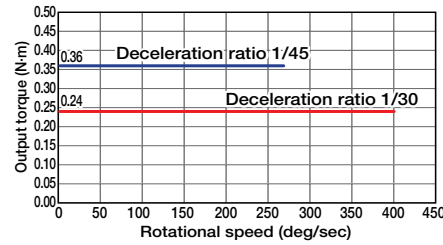

**Actuator Specifications**

■ Lead and Load Capacity

Model	Deceleration Ratio	Max. Torque (N·m)	Allowable Moment of Inertia (kg·m <sup>2</sup> )	Oscillation Angle (deg)
RCP2-RTCS-I-20P-30-330-①-②-③	1/30	0.24	0.0023	330
RCP2-RTCS-I-20P-45-330-①-②-③	1/45	0.36	0.0035	
RCP2-RTCSL-I-20P-30-360-①-②-③	1/30	0.24	0.0023	360
RCP2-RTCSL-I-20P-45-360-①-②-③	1/45	0.36	0.0035	

Legend: ① Compatible controller ② Cable length ③ Options

■ Deceleration Ratio and Max. Speed

Deceleration Ratio	Stroke	
	330/360 (deg)	(deg)
1/30	400	
1/45	266	

(Unit: degrees/s)

**Stroke List**

Type	Oscillation Angle (deg)	Standard Price
RTCS	330	-
RTCSL	360	-

**② Cable List**

Type	Cable Symbol	Standard Price
Standard Type (Robot Cables)	P (1m)	-
	S (3m)	-
	M (5m)	-
Special Lengths	X06 (6m) ~ X10 (10m)	-
	X11 (11m) ~ X15 (15m)	-
	X16 (16m) ~ X20 (20m)	-
		-

\* The standard cable is the motor-encoder integrated robot cable.  
 \* See page A-39 for cables for maintenance.

**③ Option List**

Name	Option Code	See Page	Standard Price
Reversed-rotation (*)	NM	→ A-33	-
Shaft adapter	SA	→ A-35	-
Table adapter	TA	→ A-37	-

\* Reversed-rotation option can be selected on the multi-rotational model only.

**Actuator Specifications**

Item	Description
Drive System	Hypoid gear
Positioning Repeatability	±0.05 degrees
Homing Accuracy	±0.05 degrees
Lost Motion	±0.1 degrees
Allowable Thrust Load	30N
Allowable Load Moment	3.6N·m
Weight	0.52kg
Ambient Operating Temp./Humidity	0 ~ 40°C, 85% RH or less (non-condensing)

**355** RCP2-RTCS/RTCSL

Dimensions

CAD drawings can be downloaded from IAI website. [www.intelligentactuator.com](http://www.intelligentactuator.com)

For Special Orders P. A-9

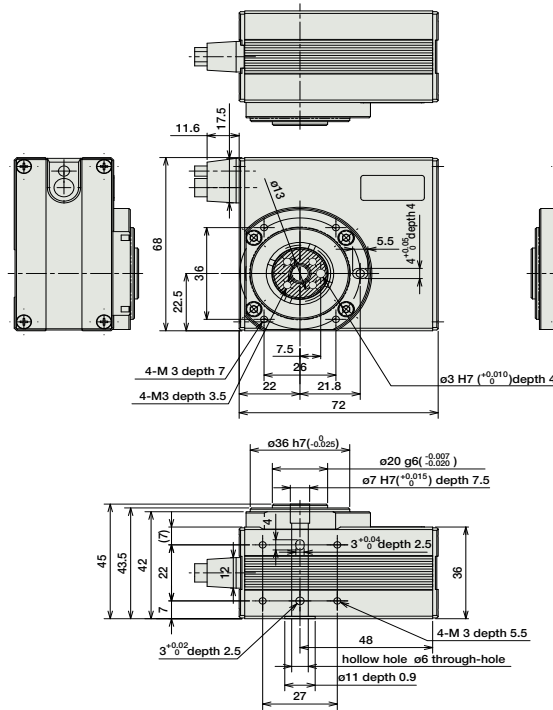

Note:  
\* In the 2D drawing on the left, the shaded area indicates the rotating part.

<sup>1</sup> The motor-encoder cable is connected here. See page A-39 for details on cables.

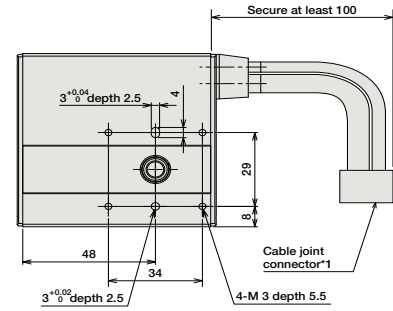

Note:  
The position in the 2D drawing on the left is the home position. When homing, the actuator rotates to the left past the home position by 1 degree. Therefore please watch for any interference with the surrounding objects. The range of motion is 330 degrees clockwise, as viewed from above.

Weight (kg) 0.48

① Compatible Controllers

The RCP2 series actuators can operate with the controllers below. Select the controller according to your usage.

Name	External View	Model	Description	Max. Positioning Points	Input Voltage	Power Supply Capacity	Standard Price	See Page
Solenoid Valve Type		PMEC-C-20PI-NP-2-①	Easy-to-use controller, even for beginners	3 points	AC100V AC200V	See P481	-	→ P477
		PSEP-C-20PI-NP-2-0	Operable with same signal as solenoid valve. Supports both single and double solenoid types. No homing necessary with simple absolute type.					→ P487
Splash-Proof Solenoid Valve Type		PSEP-CW-20PI-NP-2-0						
Positioner Type		PCON-C-20PI-NP-2-0	Positioning is possible for up to 512 points	512 points	DC24V	2A max.	-	
Safety-Compliant Positioner Type		PCON-CG-20PI-NP-2-0						
Pulse Train Input Type (Differential Line Driver)		PCON-PL-20PI-NP-2-0	Pulse train input type with differential line driver support	(-)	DC24V	2A max.	-	→ P625
Pulse Train Input Type (Open Collector)		PCON-PO-20PI-NP-2-0	Pulse train input type with open collector support					
Serial Communication Type		PCON-SE-20PI-N-0-0	Dedicated to serial communication	64 points				
Field Network Type		RPCON-20P	Dedicated to field network	768 points				→ P503
Program Control Type		PSEL-C-1-20PI-NP-2-0	Programmed operation is possible. Operation is possible on up to 2 axes	1500 points				→ P557

\* This is for the single-axis PSEL.  
\* ① is a placeholder for the power supply voltage (1: 100V, 2: 100~240V).

- Slider Type
- Mini
- Standard
- Controllers Integrated
- Rod Type
- Mini
- Standard
- Controllers Integrated
- Table/Arm /Flat Type
- Mini
- Standard
- Gripper/ Rotary Type
- Linear Servo Type
- Cleanroom Type
- Splash-Proof
- Controllers
- PMEC /AMEC
- PSEP /ASEP
- ROBO NET
- ERC2
- PCON
- ACON
- SCON
- PSEL
- ASEL
- SSEL
- XSEL
- Pulse Motor
- Servo Motor (24V)
- Servo Motor (200V)
- Linear Servo Motor



RCP2-RTCS/RTCSL **356**

# RCP2-RTB/RTBL

ROBO Cylinder Rotary Medium Vertical Type 50mm Width Pulse Motor

■ Configuration: **RCP2** —  — **I** — **28P** —  —  —  —  —

Series — Type — Encoder — Motor — Deceleration Ratio — Oscillation Angle — Compatible Controllers — Cable Length — Option

RTB : 330-degree rotation  
RTBL: Multi-rotational

I: Incremental absolute encoder is also considered type "I".

28P : 28 □ size Pulse motor  
20: 1/20 deceleration ratio  
30: 1/30 deceleration ratio

330: 330degrees (RTB only)  
360: 360degrees (RTBL only)

P1: PCON  
RPCON  
PSEL  
P3: PMEC  
PSEP

N : None  
P : 1m  
S : 3m  
M : 5m  
X □ : Custom  
R □ : Robot cable

NM : Reversed-rotation  
SA: Shaft adapter  
TA : Table adapter

\* See page Pre-35 for an explanation of the naming convention.



Technical References P. A-5

- POINT** Notes on Selection
- The output torque decreases as the rotational speed increases. Check the output torque graph on the right to see whether the speed required for your desired motion is supported.
  - The allowable moment of inertia of the rotated work piece varies with the rotational speed. Check the Allowable Moment of Inertia graph on the right to see if the moment of inertia required for your desired motion is within the allowable range.
  - The rated acceleration while moving is 0.3G.

■ Speed vs. Load Capacity  
Due to the characteristics of the Pulse motor, the RCP2 series' load capacity decreases at high speeds. In the table below, check if your desired speed and load capacity are supported.

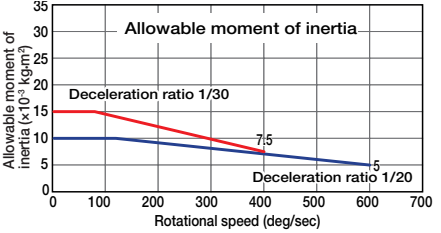
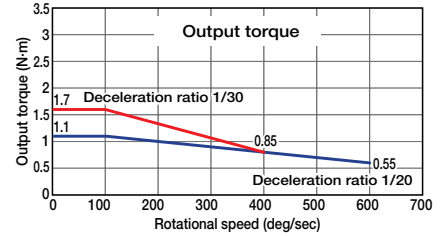

Actuator Specifications					Deceleration Ratio and Max. Speed	
■ Lead and Load Capacity					Stroke	
Model	Deceleration Ratio	Max. Torque (N·m)	Allowable Moment of Inertia (kg·m <sup>2</sup> )	Oscillation Angle (deg)	Deceleration Ratio	330/360 (deg)
RCP2-RTB-I-28P-20-330-①-②-③	1/20	1.1	0.01	330	1/20	600
RCP2-RTB-I-28P-30-330-①-②-③	1/30	1.7	0.015		1/30	400
RCP2-RTBL-I-28P-20-360-①-②-③	1/20	1.1	0.01	360		
RCP2-RTBL-I-28P-30-360-①-②-③	1/30	1.7	0.015			

Legend: ① Compatible controller ② Cable length ③ Options

(Unit: degrees/s)

Stroke List		
Type	Oscillation Angle (deg)	Standard Price
RTB	330	-
RTBL	360	-

② Cable List		
Type	Cable Symbol	Standard Price
Standard Type	P (1m)	-
	S (3m)	-
	M (5m)	-
Special Lengths	X06 (6m) ~ X10 (10m)	-
	X11 (11m) ~ X15 (15m)	-
	X16 (16m) ~ X20 (20m)	-
Robot Cable	R01 (1m) ~ R03 (3m)	-
	R04 (4m) ~ R05 (5m)	-
	R06 (6m) ~ R10 (10m)	-
	R11 (11m) ~ R15 (15m)	-
	R16 (16m) ~ R20 (20m)	-

\* See page A-39 for cables for maintenance.

③ Option List			
Name	Option Code	See Page	Standard Price
Reversed-rotation (*)	NM	→ A-33	-
Shaft adapter	SA	→ A-35	-
Table adapter	TA	→ A-37	-

\* Reversed-rotation option can be selected on the multi-rotational model only.

Actuator Specifications	
Item	Description
Drive System	Hypoid gear
Positioning Repeatability	±0.01 degrees
Homing Accuracy	±0.01 degrees
Lost Motion	±0.1 degrees
Allowable Thrust Load	50N
Allowable Load Moment	3.9 N·m
Weight	0.86kg
Ambient Operating Temp./Humidity	0 ~ 40°C, 85% RH or less (non-condensing)

# 357

RCP2-RTB/RTBL

Dimensions

CAD drawings can be downloaded from IAI website. [www.intelligentactuator.com](http://www.intelligentactuator.com)

For Special Orders P. A-9



**Note:**  
\* In the drawing on the right, the shaded area indicates the rotating part.

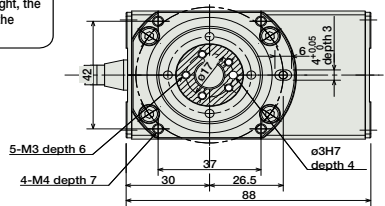

**Note:**  
The position in the drawing on the left is the home position. When homing, the actuator rotates to the left past the home position by 1 degree. Therefore please watch for any interference with the surrounding objects. The range of motion is 330 degrees clockwise, as viewed from above.

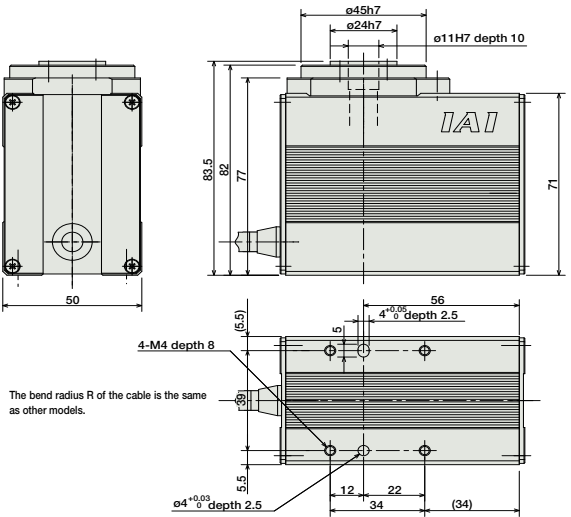

\* The bend radius R of the cable is the same as other models.

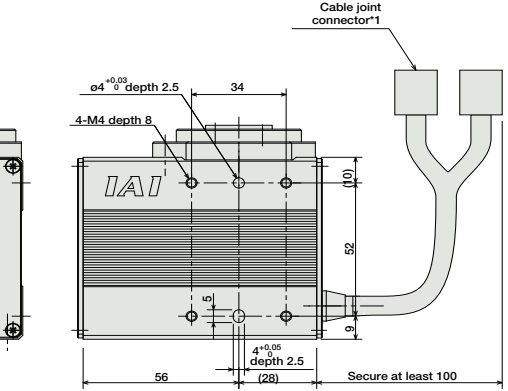

\*1 The motor-encoder cable is connected here. See page A-39 for details on cables.

Weight (kg) 0.86

① Compatible Controllers

The RCP2 series actuators can operate with the controllers below. Select the controller according to your usage.

Name	External View	Model	Description	Max. Positioning Points	Input Voltage	Power Supply Capacity	Standard Price	See Page
Solenoid Valve Type		PMEC-C-28PI-NP-2-①	Easy-to-use controller, even for beginners	3 points	AC100V AC200V	See P481	-	→ P477
		PSEP-C-28PI-NP-2-0	Operable with same signal as solenoid valve. Supports both single and double solenoid types. No homing necessary with simple absolute type.				-	→ P487
Splash-Proof Solenoid Valve Type		PSEP-CW-28PI-NP-2-0					-	
Positioner Type		PCON-C-28PI-NP-2-0	Positioning is possible for up to 512 points	512 points	DC24V	2A max.	-	→ P525
Safety-Compliant Positioner Type		PCON-CG-28PI-NP-2-0					-	
Pulse Train Input Type (Differential Line Driver)		PCON-PL-28PI-NP-2-0	Pulse train input type with differential line driver support	(-)	DC24V	2A max.	-	→ P525
Pulse Train Input Type (Open Collector)		PCON-PO-28PI-NP-2-0	Pulse train input type with open collector support				-	
Serial Communication Type		PCON-SE-28PI-N-0-0	Dedicated to serial communication	64 points			-	
Field Network Type		RPCON-28P	Dedicated to field network	768 points			-	→ P503
Program Control Type		PSEL-C-1-28PI-NP-2-0	Programmed operation is possible. Operation is possible on up to 2 axes	1500 points			-	→ P557

\* This is for the single-axis PSEL.  
\* ① is a placeholder for the power supply voltage (1: 100V, 2: 100~240V).

- Slider Type
- Mini
- Standard
- Controllers Integrated
- Rod Type
- Mini
- Standard
- Controllers Integrated
- Table/Arm /Flat Type
- Mini
- Standard
- Gripper/ Rotary Type
- Linear Servo Type
- Cleanroom Type
- Splash-Proof
- Controllers
- PMEC /AMEC
- PSEP /ASEP
- ROBO NET
- ERC2
- PCON
- ACON
- SCON
- PSEL
- ASEL
- SSEL
- XSEL
- Pulse Motor
- Servo Motor (24V)
- Servo Motor (200V)
- Linear Servo Motor



RCP2-RTB/RTBL **358**

# RCP2-RTC/RTCL ROBO Cylinder Rotary Medium Flat Type 88mm Width Pulse Motor

■ Configuration: **RCP2** —  — **I** — **28P** —  —  —  —  —

Series — Type — Encoder — Motor — Deceleration Ratio — Oscillation Angle — Compatible Controllers — Cable Length — Option

RTC: 330-degree rotation  
 RTCL: Multi-rotational

I: Incremental  
 \* The Simple absolute encoder is also considered type "I".

28P: 28 □ size Pulse motor  
 20: 1/20 deceleration ratio  
 30: 1/30 deceleration ratio

330: 330degrees (RTC only)  
 360: 360degrees (RTCL only)

P1: PCON  
 RPCON  
 PSEL  
 P3: PMEC  
 PSEP

N: None  
 P: 4m  
 S: 3m  
 M: 5m  
 X □ □ : Custom  
 R □ □ : Robot cable

NM: Reversed-rotation  
 SA: Shaft adapter  
 TA: Table adapter

\* See page Pre-35 for an explanation of the naming convention.

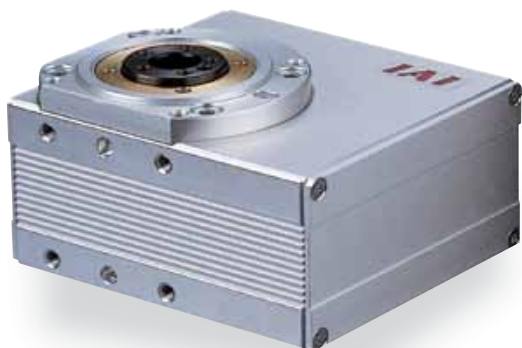

Technical References P. A-5

- POINT**  
Notes on Selection
- (1) The output torque decreases as the rotational speed increases. Check the output torque graph on the right to see whether the speed required for your desired motion is supported.
  - (2) The allowable moment of inertia of the rotated work piece varies with the rotational speed. Check the Allowable Moment of Inertia graph on the right to see if the moment of inertia required for your desired motion is within the allowable range.
  - (3) The rated acceleration while moving is 0.3G.

■ Speed vs. Load Capacity  
 Due to the characteristics of the Pulse motor, the RCP2 series' load capacity decreases at high speeds. In the table below, check if your desired speed and load capacity are supported.

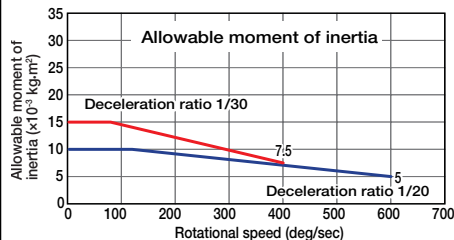
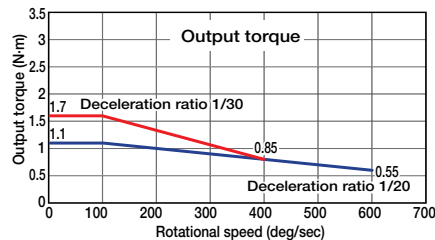

Actuator Specifications					Deceleration Ratio and Max. Speed	
■ Lead and Load Capacity					Stroke	
Model	Deceleration Ratio	Max. Torque (N·m)	Allowable Moment of Inertia (kg·m <sup>2</sup> )	Oscillation Angle (deg)	Deceleration Ratio	330/360 (deg)
RCP2-RTC-I-28P-20-330-①-②-③	1/20	1.1	0.01	330	1/20	600
RCP2-RTC-I-28P-30-330-①-②-③	1/30	1.7	0.015		1/30	400
RCP2-RTCL-I-28P-20-360-①-②-③	1/20	1.1	0.01	360		
RCP2-RTCL-I-28P-30-360-①-②-③	1/30	1.7	0.015			

Legend: ① Compatible controller ② Cable length ③ Options

(Unit: degrees/s)

Stroke List		
Type	Oscillation Angle (deg)	Standard Price
RTC	330	-
RTCL	360	-

② Cable List		
Type	Cable Symbol	Standard Price
Standard Type	P (1m)	-
	S (3m)	-
	M (5m)	-
Special Lengths	X06 (6m) ~ X10 (10m)	-
	X11 (11m) ~ X15 (15m)	-
	X16 (16m) ~ X20 (20m)	-
Robot Cable	R01 (1m) ~ R03 (3m)	-
	R04 (4m) ~ R05 (5m)	-
	R06 (6m) ~ R10 (10m)	-
	R11 (11m) ~ R15 (15m)	-
	R16 (16m) ~ R20 (20m)	-

\* See page A-39 for cables for maintenance.

③ Option List			
Name	Option Code	See Page	Standard Price
Reversed-rotation (*)	NM	→ A-33	-
Shaft adapter	SA	→ A-35	-
Table adapter	TA	→ A-37	-

\* Reversed-rotation option can be selected on the multi-rotational model only.

Actuator Specifications	
Item	Description
Drive System	Hypoid gear
Positioning Repeatability	±0.01 degrees
Homing Accuracy	±0.01 degrees
Lost Motion	±0.1 degrees
Allowable Thrust Load	50N
Allowable Load Moment	3.9 N·m
Weight	0.92kg
Ambient Operating Temp./Humidity	0 ~ 40°C, 85% RH or less (non-condensing)

# 359

RCP2-RTC/RTCL





# RCP2-RTBB/RTBBL

ROBO Cylinder Rotary Large Vertical Type 76mm Width Pulse Motor

■ Configuration: **RCP2** —  — **I** — **35P** —  —  —  —  —

Series — Type — Encoder — Motor — Deceleration Ratio — Oscillation Angle — Compatible Controllers — Cable Length — Option

RTBB : 330-degree rotation  
 RTBBL : Multi-rotational

I: Incremental absolute encoder is also considered type "I".  
 \* The Simple absolute encoder is also considered type "I".

35P : 35 □ size Pulse motor

20: 1/20 deceleration ratio  
 30: 1/30 deceleration ratio

330: 330degrees (RTBB only)  
 360: 360degrees (RTBBL only)

P1: PCON  
 RPON  
 PSEL  
 P3: PMEC  
 PSEP

N : None  
 P : 4m  
 S : 3m  
 M : 5m  
 X □ : Custom  
 R □ : Robot cable

NM : Reversed-rotation  
 SA : Shaft adapter  
 TA : Table adapter

\* See page Pre-35 for an explanation of the naming convention.



Technical References P. A-5

- POINT** Notes on Selection
- (1) The output torque decreases as the rotational speed increases. Check the output torque graph on the right to see whether the speed required for your desired motion is supported.
  - (2) The allowable moment of inertia of the rotated work piece varies with the rotational speed. Check the Allowable Moment of Inertia graph on the right to see if the moment of inertia required for your desired motion is within the allowable range.
  - (3) The rated acceleration while moving is 0.3G.

■ Speed vs. Load Capacity  
 Due to the characteristics of the Pulse Motor, the RCP2 series' load capacity decreases at high speeds. In the table below, check if your desired speed and load capacity are supported.

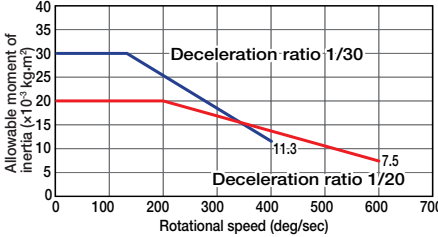
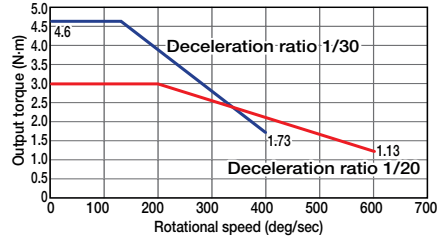

Actuator Specifications					Deceleration Ratio and Max. Speed	
■ Lead and Load Capacity					Stroke	
Model	Deceleration Ratio	Max. Torque (N·m)	Allowable Moment of Inertia (kg·m <sup>2</sup> )	Oscillation Angle (deg)	Deceleration Ratio	330/360 (deg)
RCP2-RTBB-I-35P-20-330-①-②-③	1/20	3.0	0.02	330	1/20	600
RCP2-RTBB-I-35P-30-330-①-②-③	1/30	4.6	0.03		1/30	400
RCP2-RTBBL-I-35P-20-360-①-②-③	1/20	3.0	0.02	360	(Unit: degrees/s)	
RCP2-RTBBL-I-35P-30-360-①-②-③	1/30	4.6	0.03			

Legend: ① Compatible controller ② Cable length ③ Options

Stroke List		
Type	Oscillation Angle (deg)	Standard Price
RTBB	330	-
RTBBL	360	-

② Cable List		
Type	Cable Symbol	Standard Price
Standard Type	P (1m)	-
	S (3m)	-
	M (5m)	-
Special Lengths	X06 (6m) ~ X10 (10m)	-
	X11 (11m) ~ X15 (15m)	-
	X16 (16m) ~ X20 (20m)	-
Robot Cable	R01 (1m) ~ R03 (3m)	-
	R04 (4m) ~ R05 (5m)	-
	R06 (6m) ~ R10 (10m)	-
	R11 (11m) ~ R15 (15m)	-
	R16 (16m) ~ R20 (20m)	-

\* See page A-39 for cables for maintenance.

③ Option List			
Name	Option Code	See Page	Standard Price
Reversed-rotation (*)	NM	→ A-33	-
Shaft adapter	SA	→ A-35	-
Table adapter	TA	→ A-37	-

\* Reversed-rotation option can be selected on the multi-rotational model only.

Actuator Specifications	
Item	Description
Drive System	Hypoid gear
Positioning Repeatability	±0.01 degrees
Homing Accuracy	±0.01 degrees
Lost Motion	±0.1 degrees
Allowable Thrust Load	200N
Allowable Load Moment	17.7N·m
Weight	2.3kg
Ambient Operating Temp./Humidity	0 ~ 40°C, 85% RH or less (non-condensing)

# 361

RCP2-RTBB/RTBBL

Dimensions

CAD drawings can be downloaded from IAI website. [www.intelligentactuator.com](http://www.intelligentactuator.com)

2D CAD

For Special Orders P. A-9

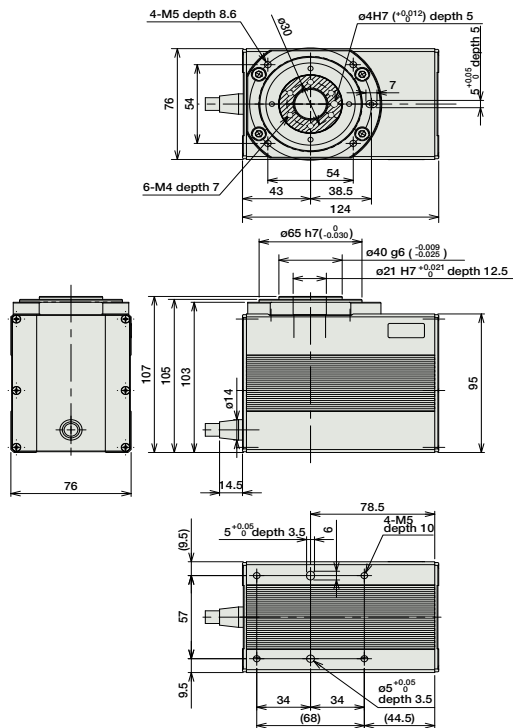

Note: \* In the 2D drawing on the left, the shaded area indicates the rotating part.

\*1 The motor-encoder cable is connected here. See page A-39 for details on cables.

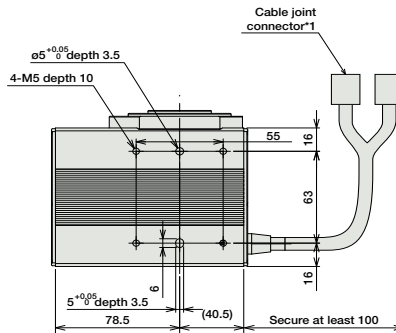

Note: The position in the 2D drawing on the left is the home position. When homing, the actuator rotates to the left past the home position by 1 degree. Therefore please watch for any interference with the surrounding objects. The range of motion is 330 degrees clockwise, as viewed from above.

Weight (kg) 2.3

① Compatible Controllers

The RCP2 series actuators can operate with the controllers below. Select the controller according to your usage.

Name	External View	Model	Description	Max. Positioning Points	Input Voltage	Power Supply Capacity	Standard Price	See Page
Solenoid Valve Type		PMEC-C-35PI-NP-2-①	Easy-to-use controller, even for beginners	3 points	AC100V AC200V	See P481	-	→ P477
		PSEP-C-35PI-NP-2-0	Operable with same signal as solenoid valve. Supports both single and double solenoid types. No homing necessary with simple absolute type.				-	→ P487
Splash-Proof Solenoid Valve Type		PSEP-CW-35PI-NP-2-0					-	
Positioner Type		PCON-C-35PI-NP-2-0	Positioning is possible for up to 512 points	512 points	DC24V	2A max.	-	→ P525
Safety-Compliant Positioner Type		PCON-CG-35PI-NP-2-0					-	
Pulse Train Input Type (Differential Line Driver)		PCON-PL-35PI-NP-2-0	Pulse train input type with differential line driver support	(-)	DC24V	2A max.	-	→ P525
Pulse Train Input Type (Open Collector)		PCON-PO-35PI-NP-2-0	Pulse train input type with open collector support				-	
Serial Communication Type		PCON-SE-35PI-N-0-0	Dedicated to serial communication	64 points			-	
Field Network Type		RPCON-35P	Dedicated to field network	768 points			-	→ P503
Program Control Type		PSEL-C-1-35PI-NP-2-0	Programmed operation is possible Operation is possible on up to 2 axes	1500 points			-	→ P557

\* This is for the single-axis PSEL.  
\* ① is a placeholder for the power supply voltage (1: 100V, 2: 100~240V).

- Slider Type
- Mini
- Standard
- Controllers Integrated
- Rod Type
- Mini
- Standard
- Controllers Integrated
- Table/Arm /Flat Type
- Mini
- Standard
- Gripper/ Rotary Type
- Linear Servo Type
- Cleanroom Type
- Splash-Proof
- Controllers
- PMEC /AMEC
- PSEP /ASEP
- ROBO NET
- ERC2
- PCON
- ACON
- SCON
- PSEL
- ASEL
- SSEL
- XSEL
- Pulse Motor
- Servo Motor (24V)
- Servo Motor (200V)
- Linear Servo Motor



# RCP2-RTCB/RTCBL

ROBO Cylinder Rotary Large Flat Type 124mm Width Pulse Motor

■ Configuration: **RCP2** —  — **I** — **35P** —  —  —  —  —

Series — Type — Encoder — Motor — Deceleration Ratio — Oscillation Angle — Compatible Controllers — Cable Length — Option

RTCB : 330-degree rotation  
 RTCBL : Multi-rotational

I: Incremental absolute encoder is also considered type "I".  
 \* The Simple absolute encoder is also considered type "I".

35P : 35 □ size Pulse motor  
 20: 1/20 deceleration ratio  
 30: 1/30 deceleration ratio  
 330: 330degrees (RTB only)  
 360: 360degrees (RTBL only)

P1: PCON  
 RPCON  
 PSEL  
 P3: PMEC  
 PSEP

N : None  
 P : 4m  
 S : 3m  
 M : 5m  
 X □ : Custom  
 R □ : Robot cable

NM : Reversed-rotation  
 SA : Shaft adapter  
 TA : Table adapter

\* See page Pre-35 for an explanation of the naming convention.



Technical References P. A-5



- (1) The output torque decreases as the rotational speed increases. Check the output torque graph on the right to see whether the speed required for your desired motion is supported.
- (2) The allowable moment of inertia of the rotated work piece varies with the rotational speed. Check the Allowable Moment of Inertia graph on the right to see if the moment of inertia required for your desired motion is within the allowable range.
- (3) The rated acceleration while moving is 0.3G.

### Speed vs. Load Capacity

Due to the characteristics of the Pulse motor, the RCP2 series' load capacity decreases at high speeds. In the table below, check if your desired speed and load capacity are supported.

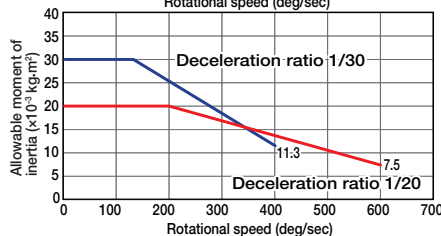
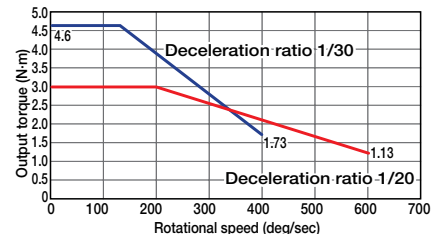

### Actuator Specifications

#### Lead and Load Capacity

Model	Deceleration Ratio	Max. Torque (N·m)	Allowable Moment of Inertia (kg·m <sup>2</sup> )	Oscillation Angle (deg)
RCP2-RTCB-I-35P-20-330-①-②-③	1/20	3.0	0.02	330
RCP2-RTCB-I-35P-30-330-①-②-③	1/30	4.6	0.03	330
RCP2-RTCBL-I-35P-20-360-①-②-③	1/20	3.0	0.02	360
RCP2-RTCBL-I-35P-30-360-①-②-③	1/30	4.6	0.03	360

Legend: ① Compatible controller ② Cable length ③ Options

#### Deceleration Ratio and Max. Speed

Stroke (Deceleration Ratio)	330/360 (deg)
1/20	600
1/30	400

(Unit: degrees/s)

#### Stroke List

Type	Oscillation Angle (deg)	Standard Price
RTCB	330	-
RTCBL	360	-

#### ② Cable List

Type	Cable Symbol	Standard Price
Standard Type	P (1m)	-
	S (3m)	-
	M (5m)	-
Special Lengths	X06 (6m) ~ X10 (10m)	-
	X11 (11m) ~ X15 (15m)	-
	X16 (16m) ~ X20 (20m)	-
Robot Cable	R01 (1m) ~ R03 (3m)	-
	R04 (4m) ~ R05 (5m)	-
	R06 (6m) ~ R10 (10m)	-
	R11 (11m) ~ R15 (15m)	-
	R16 (16m) ~ R20 (20m)	-

\* See page A-39 for cables for maintenance.

#### ③ Option List

Name	Option Code	See Page	Standard Price
Reversed-rotation (*)	NM	→ A-33	-
Shaft adapter	SA	→ A-35	-
Table adapter	TA	→ A-37	-

\* Reversed-rotation option can be selected on the multi-rotational model only.

#### Actuator Specifications

Item	Description
Drive System	Hypoid gear
Positioning Repeatability	±0.01 degrees
Homing Accuracy	±0.01 degrees
Lost Motion	±0.1 degrees
Allowable Thrust Load	200N
Allowable Load Moment	17.7N·m
Weight	2.2kg
Ambient Operating Temp./Humidity	0 ~ 40°C, 85% RH or less (non-condensing)

# 363

RCP2-RTCB/RTCBL

Dimensions

CAD drawings can be downloaded from IAI website. [www.intelligentactuator.com](http://www.intelligentactuator.com)

For Special Orders P. A-9

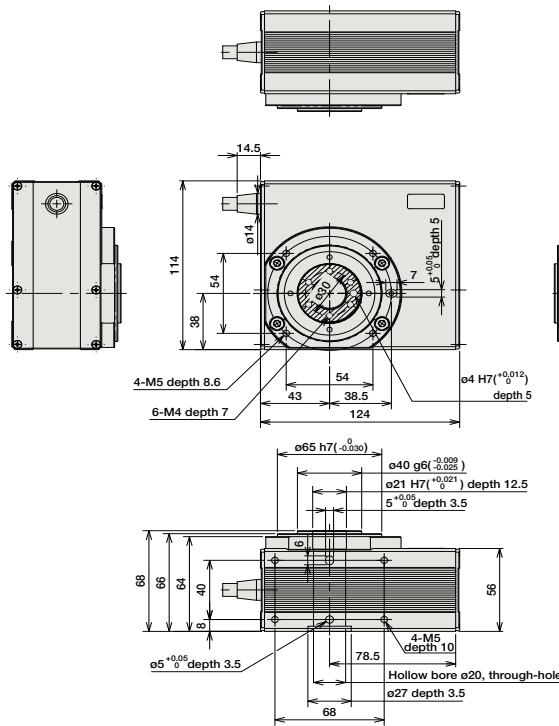

Note:  
\* In the 2D drawing on the left, the shaded area indicates the rotating part.

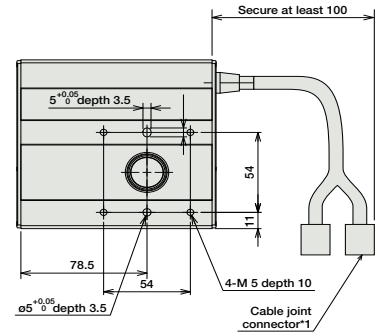

\*1 The motor-encoder cable is connected here. See page A-39 for details on cables.

Note:  
The position in the 2D drawing on the left is the home position. When homing, the actuator rotates to the left past the home position by 1 degree. Therefore please watch for any interference with the surrounding objects. The range of motion is 330 degrees clockwise, as viewed from above.

Weight (kg) 2.2

① Compatible Controllers

The RCP2 series actuators can operate with the controllers below. Select the controller according to your usage.

Name	External View	Model	Description	Max. Positioning Points	Input Voltage	Power Supply Capacity	Standard Price	See Page
Solenoid Valve Type		PMEC-C-35PI-NP-2-①	Easy-to-use controller, even for beginners	3 points	AC100V AC200V	See P481	-	→ P477
		PSEP-C-35PI-NP-2-0	Operable with same signal as solenoid valve. Supports both single and double solenoid types. No homing necessary with simple absolute type.				-	→ P487
Splash-Proof Solenoid Valve Type		PSEP-CW-35PI-NP-2-0					-	
Positioner Type		PCON-C-35PI-NP-2-0	Positioning is possible for up to 512 points	512 points	DC24V	2A max.	-	→ P525
Safety-Compliant Positioner Type		PCON-CG-35PI-NP-2-0					-	
Pulse Train Input Type (Differential Line Driver)		PCON-PL-35PI-NP-2-0	Pulse train input type with differential line driver support	(-)	DC24V	2A max.	-	→ P525
Pulse Train Input Type (Open Collector)		PCON-PO-35PI-NP-2-0	Pulse train input type with open collector support				-	
Serial Communication Type		PCON-SE-35PI-N-0-0	Dedicated to serial communication	64 points			-	
Field Network Type		RPCON-35P	Dedicated to field network	768 points			-	→ P503
Program Control Type		PSEL-C-1-35PI-NP-2-0	Programmed operation is possible. Operation is possible on up to 2 axes	1500 points			-	→ P557

\* This is for the single-axis PSEL.  
\* ① is a placeholder for the power supply voltage (1: 100V, 2: 100~240V).

- Slider Type
- Mini
- Standard
- Controllers Integrated
- Rod Type
- Mini
- Standard
- Controllers Integrated
- Table/Arm /Flat Type
- Mini
- Standard
- Gripper/ Rotary Type
- Linear Servo Type
- Cleanroom Type
- Splash-Proof
- Controllers
- PMEC /AMEC
- PSEP /ASEP
- ROBO NET
- ERC2
- PCON
- ACON
- SCON
- PSEL
- ASEL
- SSEL
- XSEL
- Pulse Motor
- Servo Motor (24V)
- Servo Motor (200V)
- Linear Servo Motor

# RCS2-RT6

ROBO Cylinder Rotary Straight Motor Model 64mm Width 200V Servo Motor

■ Configuration: **RCS2** — **RT6** — **I** — **60** — **18** — **300** —  —  — **L**

Series — Type — Encoder — Motor — Deceleration Ratio — Oscillation Angle — Compatible Controllers — Cable Length — Option

I: Incremental    60: 60W Servo Motor    18: 1/18    300: 300degrees    T1:XSEL-J/K    N: None    L: Limit switch (equipped as standard)  
 T2:SCON    P: 1m    S: 3m  
 SSEL    M: 5m  
 XSEL-P/Q    X: Custom    R: Robot cable

\* See page Pre-35 for an explanation of the naming convention.

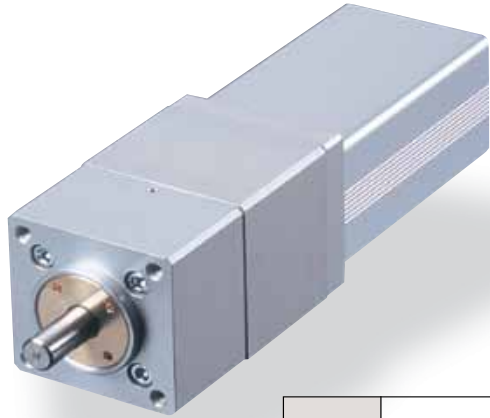

Technical References P. A-5

**POINT** Notes on Selection

- (1) The thrust load is the mechanical strength of the output axis at rest. When selecting, take into account the load moment and the load inertia.
- (2) The rated acceleration while moving is 0.3G.

Actuator Specifications						Stroke and Maximum Speed	
■ Lead and Load Capacity						■ Stroke and Maximum Speed	
Model	Motor Output (W)	Deceleration Ratio	Rated torque (N·m)	Allowable Moment of Inertia (kg·m <sup>2</sup> )	Oscillation Angle (deg)	Oscillation Angle / Deceleration Ratio	300 (deg)
RCS2-RT6-I-60-18-300-①-②-L	60	1/18	2.4	2.5×10 <sup>-2</sup> or less	300	1/18	500

Legend: ① Compatible controller    ② Cable length    (Unit: degrees/s)

Stroke List	
Oscillation Angle (deg)	Standard Price
300	-

② Cable List		
Type	Cable Symbol	Standard Price
Standard Type	P (1m)	-
	S (3m)	-
	M (5m)	-
Special Lengths	X06 (6m) ~ X10 (10m)	-
	X11 (11m) ~ X15 (15m)	-
	X16 (16m) ~ X20 (20m)	-
Robot Cable	R01 (1m) ~ R03 (3m)	-
	R04 (4m) ~ R05 (5m)	-
	R06 (6m) ~ R10 (10m)	-
	R11 (11m) ~ R15 (15m)	-
	R16 (16m) ~ R20 (20m)	-

\* See page A-39 for cables for maintenance.

Actuator Specifications	
Item	Description
Drive System	Ball speed reducer
Positioning Repeatability	±0.02 degrees
Lost Motion	0.1 degrees or less
Base	Material: Aluminum (white alumite treated)
Allowable Load Moment	6.8N·m or less
Thrust load	100N or less
Ambient Operating Temp./Humidity	0 ~ 40°C, 85% RH or less (non-condensing)

# 365

RCS2-RT6

- Slider Type
- Mini
- Standard
- Controllers Integrated
- Rod Type
- Mini
- Standard
- Controllers Integrated
- Table/Arm /Flat Type
- Mini
- Standard
- Gripper/ Rotary Type
- Linear Servo Type
- Cleanroom Type
- Splash-Proof
- Controllers
- PMEC /AMEC
- PSEP /ASEP
- ROBO NET
- ERC2
- PCON
- ACON
- SCON
- PSEL
- ASEL
- SSEL
- XSEL
- Pulse Motor
- Servo Motor (24V)
- Servo Motor (200V)
- Linear Servo Motor

Dimensions

CAD drawings can be downloaded from IAI website. [www.intelligentactuator.com](http://www.intelligentactuator.com)

For Special Orders P. A-9



\* For more information on homing, see page A-79.

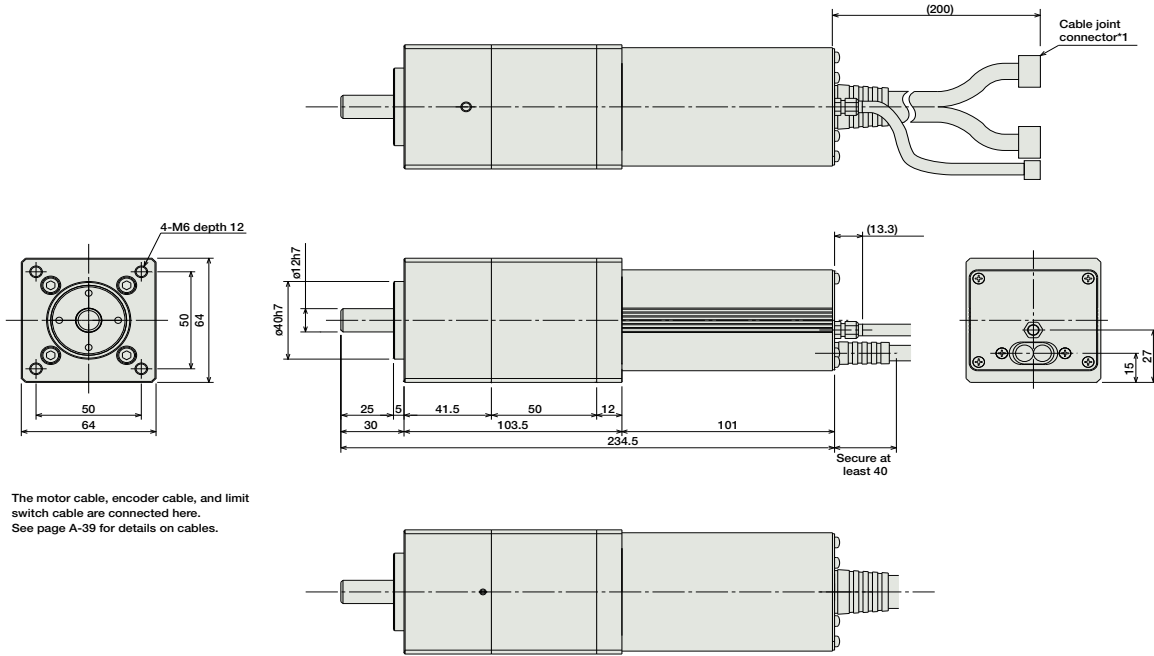

\*1 The motor cable, encoder cable, and limit switch cable are connected here. See page A-39 for details on cables.

Weight (kg) 1.9

① Compatible Controllers

The RCS2 series actuators can operate with the controllers below. Select the controller according to your usage.

Name	External View	Model	Description	Max. Positioning Points	Input Voltage	Power Supply Capacity	Standard Price	See Page
Positioner Mode		SCON-C-60-NP-2-①	Positioning is possible for up to 512 points	512 points	Single-phase AC100V Single-phase AC200V Three-phase AC200V (XSEL-P/Q only)	360VA max.  * When operating a 150W single-axis model	-	→ P547
Solenoid Valve Mode			Operable with the same controls as the solenoid valve	7 points				
Serial Communication Type			Dedicated to serial communication	64 points				
Pulse Train Input Control Type			Dedicated to pulse train input	(-)				
Program Control 1-2 Axes Type		SSEL-C-1-60-NP-2-①	Programmed operation is possible Operation is possible on up to 2 axes	20000 points			-	→ P577
Program Control 1-6 Axes Type		XSEL-2-1-60-N1-EEE-2-③	Programmed operation is possible Operation is possible on up to 6 axes	20000 points			-	→ P587

\* For SSEL and XSEL, only applicable to the single-axis model.  
 \* ① is a placeholder for the power supply voltage (1: 100V, or 2: single-phase 200V).  
 \* ② is a placeholder for the type name of XSEL (\*J\*, \*K\*, \*P\*, \*Q\*).  
 \* ③ is a placeholder for the type of power supply voltage (1: 100V, 2: single-phase 200V, or 3: 3-phase 200V).

- Slider Type
- Mini
- Standard
- Controllers Integrated
- Rod Type
- Mini
- Standard
- Controllers Integrated
- Table/Arm /Flat Type
- Mini
- Standard
- Gripper/ Rotary Type
- Linear Servo Type
- Cleanroom Type
- Splash-Proof
- Controllers
- PMEC /AMEC
- PSEP /ASEP
- ROBO NET
- ERC2
- PCON
- ACON
- SCON
- PSEL
- ASEL
- SSEL
- XSEL
- Pulse Motor
- Servo Motor (24V)
- Servo Motor (200V)
- Linear Servo Motor



RCS2-RT6 **366**

# RCS2-RT6R

ROBO Cylinder Rotary Side-Mounted Motor 64mm Width 200V Servo Motor

■ Configuration: **RCS2** — **RT6R** — **I** — **60** — **18** — **300** —  —  — **L**

Series — Type — Encoder — Motor — Deceleration Ratio — Oscillation Angle — Compatible Controllers — Cable Length — Option

I: Incremental    60: 60W Servo Motor    18: 1/18    300: 300degrees    T1:XSEL-J/K    N: None    L: Limit switch (equipped as standard)  
 T2:SCON    P: 1m    S: 3m  
 SSEL    M: 5m  
 XSEL-P/Q    X : Custom  
    R : Robot cable

\* See page Pre-35 for an explanation of the naming convention.

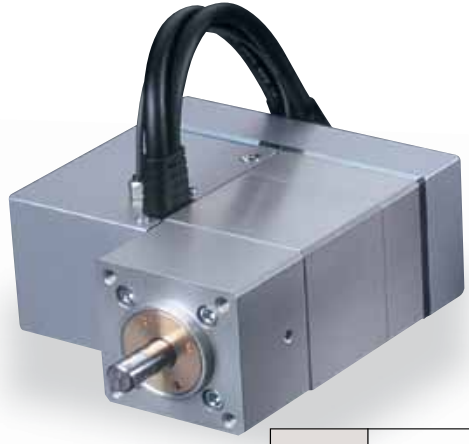

Technical References P. A-5

**POINT** Notes on Selection

(1) The thrust load is the mechanical strength of the output axis at rest. When selecting, take into account the load moment and the load inertia.

(2) The rated acceleration while moving is 0.3G.

Actuator Specifications						Stroke and Maximum Speed	
■ Lead and Load Capacity						■ Stroke and Maximum Speed	
Model	Motor Output (W)	Deceleration Ratio	Rated torque (N·m)	Allowable Moment of Inertia (kg·m <sup>2</sup> )	Oscillation Angle (deg)	Oscillation Angle / Deceleration Ratio	300 (deg)
RCS2-RT6R-I-60-18-300-①-②-L	60	1/18	2.4	2.5×10 <sup>-2</sup> or less	300	1/18	500

Legend: ① Compatible controller    ② Cable length    (Unit: degrees/s)

Stroke List	
Oscillation Angle (deg)	Standard Price
300	-

② Cable List		
Type	Cable Symbol	Standard Price
Standard Type	P (1m)	-
	S (3m)	-
	M (5m)	-
Special Lengths	X06 (6m) ~ X10 (10m)	-
	X11 (11m) ~ X15 (15m)	-
	X16 (16m) ~ X20 (20m)	-
Robot Cable	R01 (1m) ~ R03 (3m)	-
	R04 (4m) ~ R05 (5m)	-
	R06 (6m) ~ R10 (10m)	-
	R11 (11m) ~ R15 (15m)	-
	R16 (16m) ~ R20 (20m)	-

\* See page A-39 for cables for maintenance.

Actuator Specifications	
Item	Description
Drive System	Ball speed reducer + timing belt
Positioning Repeatability	±0.02 degrees
Lost Motion	0.1 degrees or less
Base	Material: Aluminum (white alumite treated)
Allowable Load Moment	6.8N·m or less
Thrust load	100N or less
Ambient Operating Temp./Humidity	0 ~ 40°C, 85% RH or less (non-condensing)

# 367

RCS2-RT6R

- Slider Type
- Mini
- Standard
- Controllers Integrated
- Rod Type
- Mini
- Standard
- Controllers Integrated
- Table/Arm/Flat Type
- Mini
- Standard
- Gripper/ Rotary Type
- Linear Servo Type
- Cleanroom Type
- Splash-Proof
- Controllers
- PMEC /AMEC
- PSEP /ASEP
- ROBO NET
- ERC2
- PCON
- ACON
- SCON
- PSEL
- ASEL
- SSEL
- XSEL
- Pulse Motor
- Servo Motor (24V)
- Servo Motor (200V)
- Linear Servo Motor

Dimensions

CAD drawings can be downloaded from IAI website. [www.intelligentactuator.com](http://www.intelligentactuator.com)

For Special Orders P. A-9



\* For more information on homing, see page A-79.

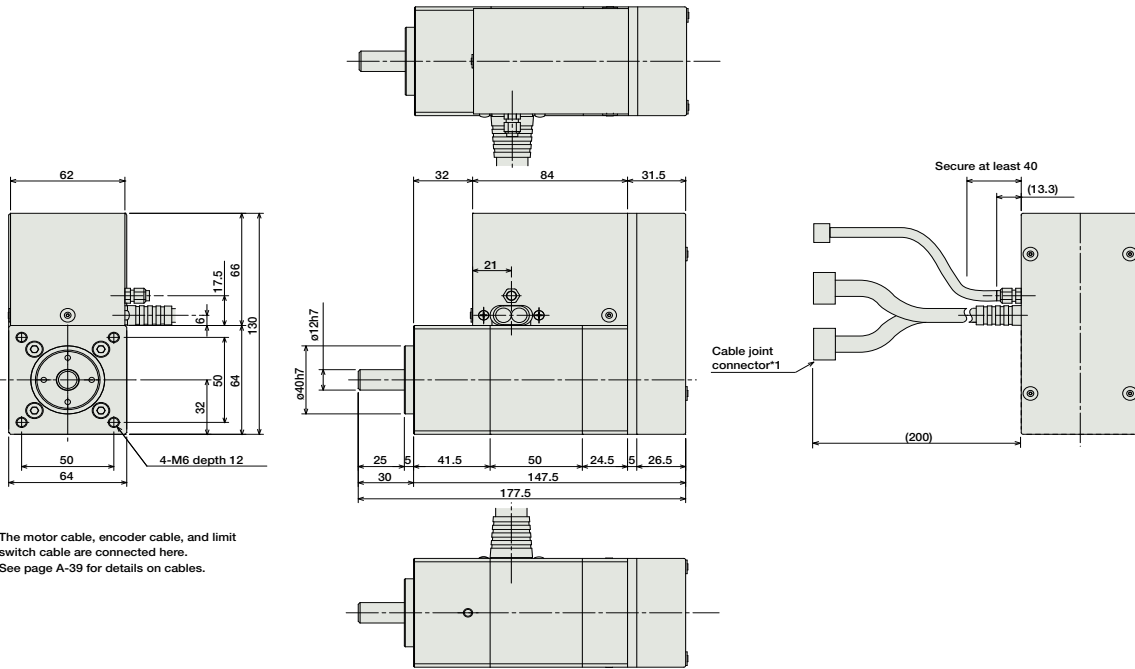

\*1 The motor cable, encoder cable, and limit switch cable are connected here. See page A-39 for details on cables.

Weight (kg) 2.8

① Compatible Controllers

The RCS2 series actuators can operate with the controllers below. Select the controller according to your usage.

Name	External View	Model	Description	Max. Positioning Points	Input Voltage	Power Supply Capacity	Standard Price	See Page
Positioner Mode		SCON-C-60-NP-2-①	Positioning is possible for up to 512 points	512 points	Single-phase AC100V Single-phase AC200V Three-phase AC200V (XSEL-P/Q only)	360VA max.  * When operating a 150W single-axis model	-	→ P547
Solenoid Valve Mode			Operable with the same controls as the solenoid valve	7 points				
Serial Communication Type			Dedicated to serial communication	64 points				
Pulse Train Input Control Type			Dedicated to pulse train input	(-)				
Program Control 1-2 Axes Type		SSEL-C-1-60-NP-2-①	Programmed operation is possible Operation is possible on up to 2 axes	20000 points			-	→ P577
Program Control 1-6 Axes Type		XSEL-2-1-60-N1-EEE-2-③	Programmed operation is possible Operation is possible on up to 6 axes	20000 points			-	→ P587

\* For SSEL and XSEL, only applicable to the single-axis model.  
 \* ① is a placeholder for the power supply voltage (1: 100V, or 2: single-phase 200V).  
 \* ② is a placeholder for the type name of XSEL ("J", "K", "P", "Q").  
 \* ③ is a placeholder for the type of power supply voltage (1: 100V, 2: single-phase 200V, or 3: 3-phase 200V).



RCS2-RT6R 368

- Slider Type
- Mini
- Standard
- Controllers Integrated
- Rod Type
- Mini
- Standard
- Controllers Integrated
- Table/Arm /Flat Type
- Mini
- Standard
- Gripper/ Rotary Type
- Linear Servo Type
- Cleanroom Type
- Splash-Proof
- Controllers
- PMEC /AMEC
- PSEP /ASEP
- ROBO NET
- ERC2
- PCON
- ACON
- SCON
- PSEL
- ASEL
- SSEL
- XSEL
- Pulse Motor
- Servo Motor (24V)
- Servo Motor (200V)
- Linear Servo Motor

# RCS2-RT7R

ROBO Cylinder Rotary Side-Mounted Motor (Hollow Motor Shaft) 68mm Width  
200V Servo Motor

■ Configuration: **RCS2** — **RT7R** — **I** — **60** — **4** — **300** —  —  — **L**

Series — Type — Encoder — Motor — Deceleration Ratio — Oscillation Angle — Compatible Controllers — Cable Length — Option

I: Incremental    60 : 60W Servo Motor    4: 1/4    300: 300degrees    T1: XSEL-J/K    N : None    L : Limit switch (equipped as standard)  
 T2: SCON    P : 1m    S : 3m    M : 5m  
 SSEL    X : Custom  
 XSEL-P/Q    R : Robot cable

\* See page Pre-35 for an explanation of the naming convention.



Technical References P. A-5

**POINT** Notes on Selection

- (1) The thrust load is the mechanical strength of the output axis at rest. When selecting, take into account the load moment and the load inertia.
- (2) The rated acceleration while moving is 0.3G.

Actuator Specifications						Stroke and Maximum Speed	
■ Lead and Load Capacity						■ Stroke and Maximum Speed	
Model	Motor Output (W)	Deceleration Ratio	Rated torque (N·m)	Allowable Moment of Inertia (kg·m <sup>2</sup> )	Oscillation Angle (deg)	Oscillation Angle / Deceleration Ratio	300 (deg)
RCS2-RT7R-I-60-4-300-①-②-L	60	1/4	0.764	1.25×10 <sup>-3</sup> or less	300	1/4	500

Legend: ① Compatible controller    ② Cable length    (Unit: degrees/s)

Stroke List	
Oscillation Angle (deg)	Standard Price
300	-

② Cable List		
Type	Cable Symbol	Standard Price
Standard Type	P (1m)	-
	S (3m)	-
	M (5m)	-
Special Lengths	X06 (6m) ~ X10 (10m)	-
	X11 (11m) ~ X15 (15m)	-
	X16 (16m) ~ X20 (20m)	-
Robot Cable	R01 (1m) ~ R03 (3m)	-
	R04 (4m) ~ R05 (5m)	-
	R06 (6m) ~ R10 (10m)	-
	R11 (11m) ~ R15 (15m)	-
	R16 (16m) ~ R20 (20m)	-

\* See page A-39 for cables for maintenance.

Actuator Specifications	
Item	Description
Drive System	Timing Belt
Positioning Repeatability	±0.1 degrees
Lost Motion	0.5 degrees or less
Base	Material: Aluminum (white alumite treated)
Allowable Load Moment	8.9N·m or less
Thrust load	100N or less
Ambient Operating Temp./Humidity	0 ~ 40°C, 85% RH or less (non-condensing)

# 369

RCS2-RT7R

- Slider Type
- Mini
- Standard
- Controllers Integrated
- Rod Type
- Mini
- Standard
- Controllers Integrated
- Table/Arm /Flat Type
- Mini
- Standard
- Gripper/ Rotary Type
- Linear Servo Type
- Cleanroom Type
- Splash-Proof
- Controllers
- PMEC /AMEC
- PSEP /ASEP
- ROBO NET
- ERC2
- PCON
- ACON
- SCON
- PSEL
- ASEL
- SSEL
- XSEL
- Pulse Motor
- Servo Motor (24V)
- Servo Motor (200V)
- Linear Servo Motor

Dimensions

CAD drawings can be downloaded from IAI website. [www.intelligentactuator.com](http://www.intelligentactuator.com)

For Special Orders P. A-9



\* For more information on homing, see page A-79.

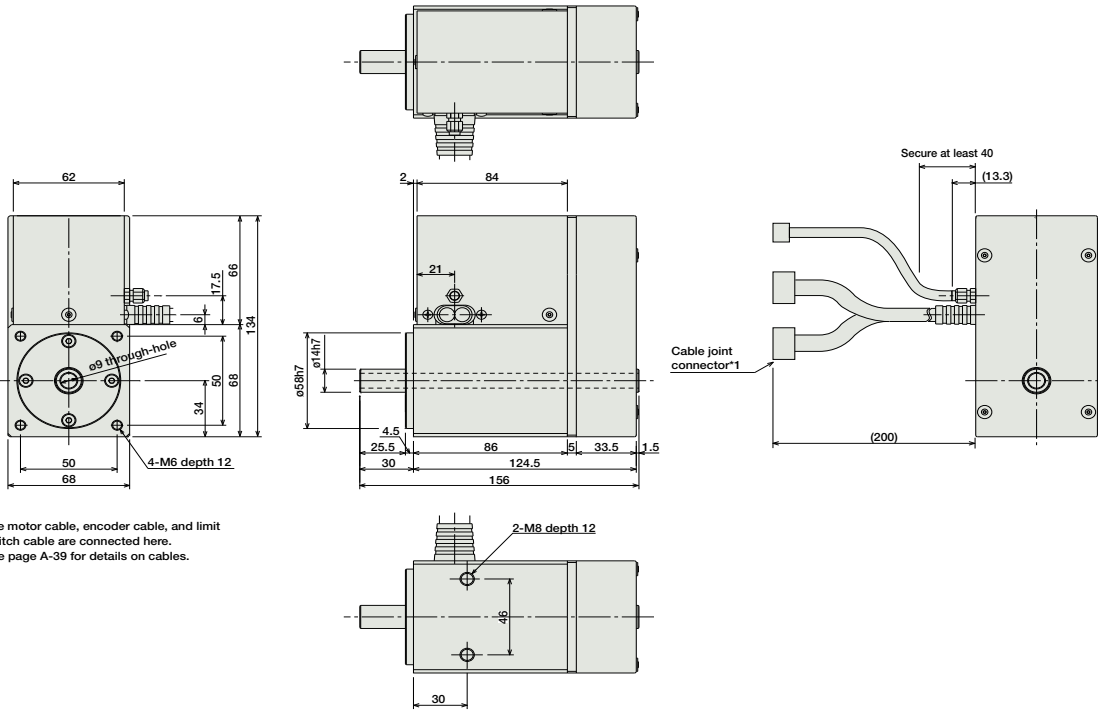

\*1 The motor cable, encoder cable, and limit switch cable are connected here. See page A-39 for details on cables.

Weight (kg) 2.6

① Compatible Controllers

The RCS2 series actuators can operate with the controllers below. Select the controller according to your usage.

Name	External View	Model	Description	Max. Positioning Points	Input Voltage	Power Supply Capacity	Standard Price	See Page
Positioner Mode		SCON-C-60-NP-2-①	Positioning is possible for up to 512 points	512 points	Single-phase AC100V Single-phase AC200V Three-phase AC200V (XSEL-P/Q only)	360VA max.  * When operating a 150W single-axis model	-	→ P547
Solenoid Valve Mode			Operable with the same controls as the solenoid valve	7 points				
Serial Communication Type			Dedicated to serial communication	64 points				
Pulse Train Input Control Type			Dedicated to pulse train input	(-)				
Program Control 1-2 Axes Type		SSEL-C-1-60-NP-2-①	Programmed operation is possible Operation is possible on up to 2 axes	20000 points			-	→ P577
Program Control 1-6 Axes Type		XSEL-2-1-60-N1-EEE-2-③	Programmed operation is possible Operation is possible on up to 6 axes	20000 points			-	→ P587

\* For SSEL and XSEL, only applicable to the single-axis model.  
 \* ① is a placeholder for the power supply voltage (1: 100V, or 2: single-phase 200V).  
 \* ② is a placeholder for the type name of XSEL ("J", "K", "P", "Q").  
 \* ③ is a placeholder for the type of power supply voltage (1: 100V, 2: single-phase 200V, or 3: 3-phase 200V).

- Slider Type
- Mini
- Standard
- Controllers Integrated
- Rod Type
- Mini
- Standard
- Controllers Integrated
- Table/Arm /Flat Type
- Mini
- Standard
- Gripper/ Rotary Type
- Linear Servo Type
- Cleanroom Type
- Splash-Proof
- Controllers
- PMEC /AMEC
- PSEP /ASEP
- ROBO NET
- ERC2
- PCON
- ACON
- SCON
- PSEL
- ASEL
- SSEL
- XSEL
- Pulse Motor
- Servo Motor (24V)
- Servo Motor (200V)
- Linear Servo Motor



RCS2-RT7R **370**