

## AC Synchronous Motors

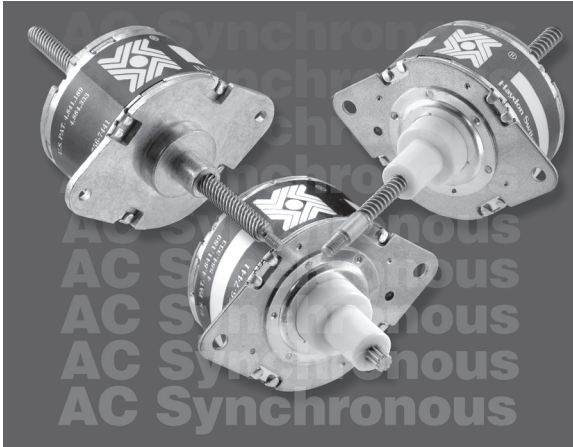

Stepping motors can also be run on AC (Alternating Current). However, one phase must be energized through a properly selected capacitor. In this case the motor is limited to only one synchronous speed. For instance, if 60 hertz is being supplied, there are 120 reversals or alterations of the power source. The phase being energized by a capacitor is also producing the same number of alterations at an offset time sequence. The motor is really being energized at the equivalent of 240 steps per second. For a 15° rotary motor, 24 steps are required to make one revolution (24 SPR). This becomes a 600 RPM synchronous motor.

$$\frac{240 \text{ Steps per Revolution} \times 60 \text{ seconds}}{24 \text{ Steps per Revolution}} = 600 \text{ RPM}$$

In the case of a linear actuator the linear speed produced is dependent on the resolution per step of the motor. For example if 60 hertz is supplied to a .001-in/step motor the resulting speed is .240-in per second (240 steps per second times .001-in/step). Many of the Haydon™ stepping motors are available as 300 or 600 RPM AC synchronous motors.

## AC Hybrid Linear Actuators

### Electrical Data

Series	Size	Watts	AMPS	Capacitor	Capacitor	Coil Resistance		Connection Diagram
				(Mfd) @ 60 Hz	(Mfd) @ 50 Hz	(Ohms) Main Wind.	(Ohms) Cap. Wind.	
<b>35000</b>	14	5.7	0.21	15	15	300	300	3
<b>43000</b>	17	6.5	0.27	15	15	104	104	3
<b>57000</b>	23	13.0	0.60	30	40	35	35	3
<b>87000*</b>	34	30.0	2.00	200	200	2.3	2.3	4

\* With 12 OHM, 100 watt resistor in series

Diag. 3

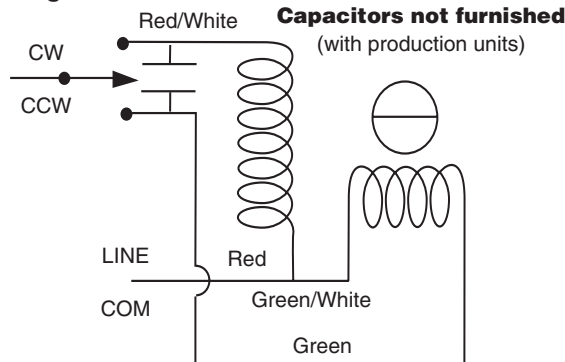

Diag. 4

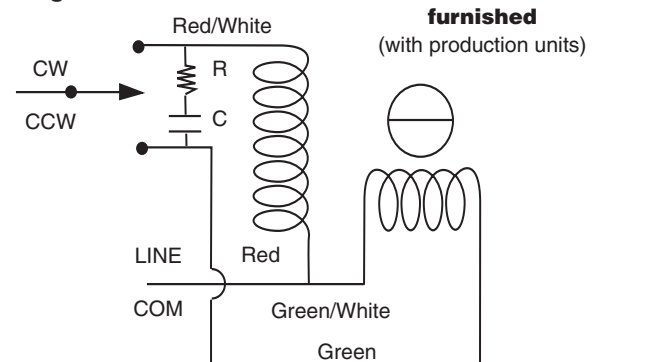

Motor part numbers are for a captive shaft. **For a non-captive shaft**, change the middle letter from an "H" to an "F". Example 1: A35H47-24 with a non-captive shaft becomes A35F47-24.

**Exception:** A43K4U-24 and A43K4V-24, for a non-captive shaft substitute "J" in place of the "K".

Example 2: A43K4U-24 with a non-captive shaft becomes A43J4U-24.

**For an external linear shaft**, add the three digit suffix - 800 to the captive shaft part number.

Example 3: A35H47-24 with an external linear shaft becomes A35H47-24-800.

All standard motors operate at 24 Volts, represented in the part number by the suffix - 24 (A35H47-24).

## AC Can-Stack Linear Actuators

For electrical data refer to the Rotary Motor Chart below.

Motor Part No.	Linear Speed @ 60 Hz		Linear Speed @ 50 Hz		Maximum Force	
	(inches/sec.)	(cm/sec.)	(inches/sec.)	(cm/sec.)	(lbs.)	(Newtons)
Z20541-24-700	0.24	0.610	0.20	0.508	5.5	24
Z20542-24-700	0.48	1.219	0.40	1.016	3.0	13
Z20544-24-700	0.96	2.438	0.80	2.032	1.8	8
A26443-24	0.12	0.305	0.10	0.254	7.4	33
A26441-24	0.24	0.610	0.20	0.508	4.4	20
A26542-24	0.48	1.219	0.40	1.016	3.5	16
A26544-24	0.96	2.438	0.80	2.032	2.0	9
Z26443-24-700	0.12	0.305	0.10	0.254	13.0	58
Z26441-24-700	0.24	0.610	0.20	0.508	8.3	37
Z26542-24-700	0.48	1.219	0.40	1.016	6.6	29
Z26544-24-700	0.96	2.438	0.80	2.032	3.3	15
A36443-24 **	0.12	0.305	0.10	0.254	16.0	71
A36441-24 **	0.24	0.610	0.20	0.508	12.0	53
A36442-24 **	0.48	1.219	0.40	1.016	6.0	27
A36544-24 **	0.96	2.438	0.80	2.032	3.0	13
A46443-24 **	0.12	0.305	0.10	0.254	43	191
A46441-24 **	0.24	0.610	0.20	0.508	34	151
A46442-24 **	0.48	1.219	0.40	1.016	20	89
A46544-24 **	0.96	2.438	0.80	2.032	11	49
A46548-24 **	1.92	4.877	1.60	4.064	5.4	24
A4654G-24 **	3.84	9.754	3.20	8.128	2.7	12

\*\* Select motors available with 24 Volts or 120 Volts (replace 24 with 120).

Motor part numbers are for a captive shaft. **For a non-captive shaft**, change the third digit from a "4" to an "3".

Example 1: A26**4**41-24 with a non-captive shaft becomes A26**3**41-24.

**Exception:** When the third digit is "5"

for a non-captive shaft substitute "8". Example 2: A26**5**44-24 with a non-captive shaft becomes A26**8**44-24.

**For an external linear shaft**, add the three digit suffix - 800 to the captive shaft part number.

Example 3: A26441-24 with an external linear shaft becomes A26441-24-**800**.

All standard motors operate at 24 Volts, represented in the part number by the suffix - 24 (A36443-**24**).

## AC Rotary Motors

Motor Part No.	Rotary Speed (RPMs) @		Torque		Watts	Amps	Capacitor @		Connection Diagram	Coil Resistance (Ohms)	
	60 Hz	50 Hz	(oz-in)	(N-cm)			60 Hz	50 Hz		Main Wind.	Cap. Wind.
Z20540-24-700	600	500	0.5	0.4	2.5	.15	12.5	12.5	2	300	75
A26440-24	300	250	0.9	0.6	3.4	.20	15.0	15.0	2	214	54
A26540-24	600	500	0.9	0.6	3.4	.20	15.0	20.0	2	214	54
Z26440-24-700	300	250	1.2	0.8	3.4	.19	15.0	15.0	2	214	54
Z26540-24-700	600	500	1.5	1.1	3.4	.19	15.0	15.0	2	214	54
A36240-24	150	125	2.5	1.8	4.6	.23	20.0	20.0	2	160	40
A36440-24	300	250	2.6	1.8	4.6	.23	20.0	20.0	2	160	40
A36540-24	600	500	1.3	0.9	4.6	.23	20.0	20.0	2	160	40
A46440-24	300	250	8.5	6.0	10.0	.38	20.0	20.0	1	29	29
A46540-24	600	500	6.5	4.6	10.0	.38	20.0	25.0	1	58	58
A36240-120	150	125	2.5	1.8	4.6	.05	0.8	0.8	2	4000	1000
A36440-120	300	250	2.6	1.8	4.6	.05	0.8	0.8	2	4000	1000
A36540-120	600	500	1.3	0.9	4.6	.05	0.8	0.8	2	4000	1000
A46440-120	300	250	8.5	6.0	10.0	.08	0.8	0.8	1	725	725
A46540-120	600	500	6.5	4.6	10.0	.08	0.8	1.0	1	1450	1450

