

HarmonicDrive®

Speed Reducers for Precision Motion Control

HarmonicDrive® Reducer Catalog

- Component Sets SHG/SHF
- Engineering Data

Sold & Serviced by:

 **ELECTROMATE**

Toll Free Phone: (877) SERV098
Toll Free Fax: (877) SERV099

www.electromate.com
sales@electromate.com

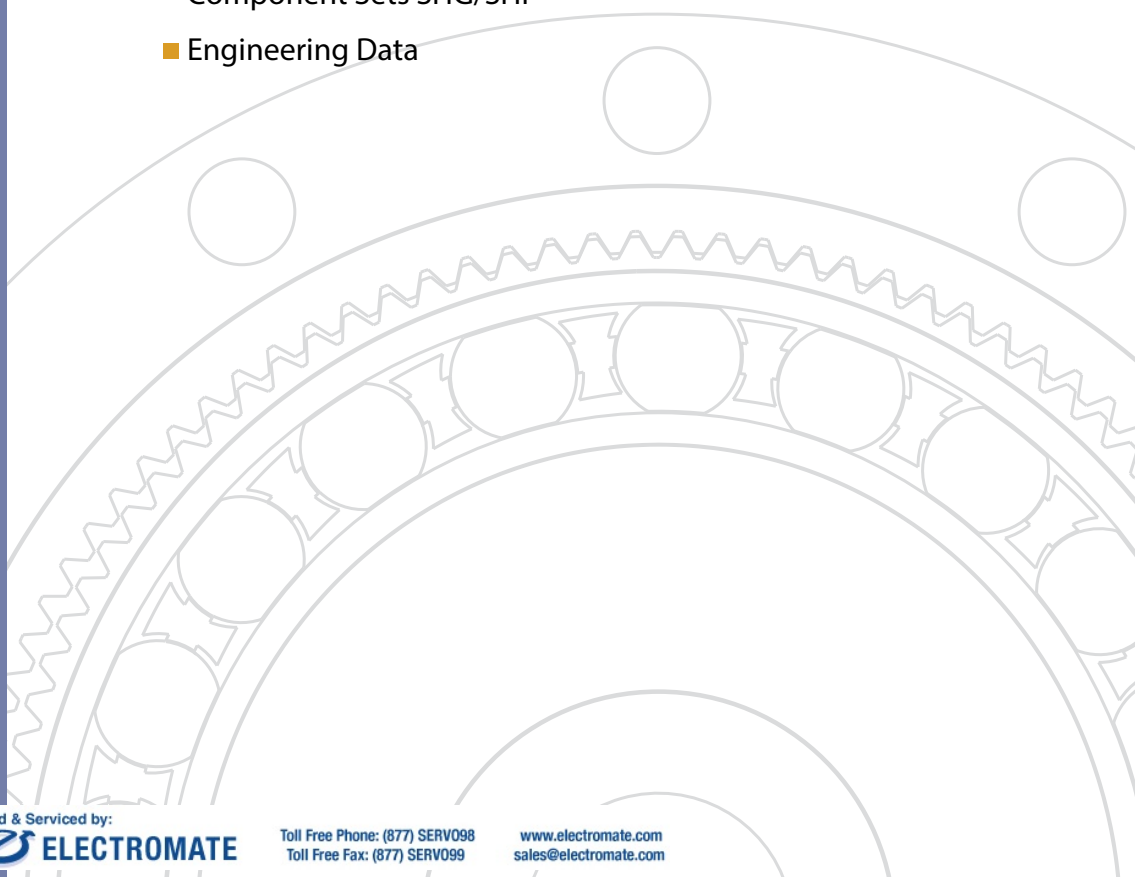

Excellent Technology for Evolving Industries

Harmonic Drive® actuators utilize high-precision, zero-backlash Harmonic Drive® precision gears and play critical roles in robotics, semiconductor manufacturing equipment, factory automation equipment, medical diagnostics and surgical robotics. Additionally, our products are frequently used in mission-critical spaceflight applications which capture the human spirit.

With over 50 years of experience, our expert engineering and production teams continually develop enabling technologies for the evolving motion control market. We are proud of our outstanding engineering capabilities and successful history of providing customer specific solutions to meet their application requirements.

Harmonic Drive LLC continues to develop enabling technologies for the evolving motion control market, which drives the pace of global innovation.

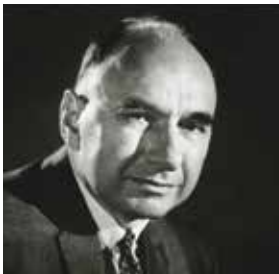

C. Walton Musser
Patented Strain Wave
Gearing in 1955

Operating Principle of HarmonicDrive® Gears

A simple three-element construction combined with the unique operating principle puts extremely high reduction ratio capabilities into a very compact and lightweight package. The high-performance attributes of this gearing technology including, zero-backlash, high-torque-to-weight ratio, compact size, and excellent positional accuracy, are a direct result of the unique operating principles.



Wave Generator
The Wave Generator is a thin, raced-ball bearing fitted onto an elliptical hub. This serves as a high-efficiency torque converter and is generally mounted onto the input or motor shaft.

Flexspline
The Flexspline is a non-rigid, thin cylindrical cup with external teeth on the open end of the cup. The Flexspline fits over the Wave Generator and takes on its elliptical shape. The Flexspline is generally used as the output of the gear.

Circular Spline
The Circular Spline is a rigid ring with internal teeth. It engages the teeth of the Flexspline across the major axis of the Wave Generator ellipse. The Circular Spline has two more teeth than the Flexspline and is generally mounted onto a housing.

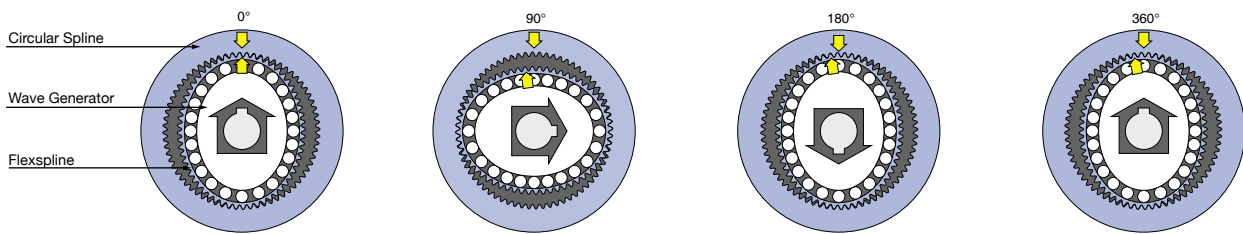

The Flexspline is slightly smaller in diameter than the Circular Spline and usually has two fewer teeth than the Circular Spline. The elliptical shape of the Wave Generator causes the teeth of the Flexspline to engage the Circular Spline at two opposite regions across the major axis of the ellipse.

As the Wave Generator rotates the teeth of the Flexspline engage with the Circular Spline at the major axis.

For every 180 degree clockwise movement of the Wave Generator, the Flexspline rotates counterclockwise by one tooth in relation to the Circular Spline.

Each complete clockwise rotation of the Wave Generator results in the Flexspline moving counterclockwise by two teeth from its original position, relative to the Circular Spline. Normally, this motion is taken out as output.

Development of HarmonicDrive® Speed Reducers



Harmonic Drive® gears have been evolving since the strain wave gear was first patented in 1955. Our innovative development and engineering teams have led us to significant advances in our gear technology. In 1988, Harmonic Drive successfully designed and manufactured a new tooth profile, the "S" tooth. Since implementing the "S" tooth profile, improvement in life, strength and torsional stiffness have been realized. In the 1990s, we focused engineering efforts on designing gears featuring space savings, higher speed, higher load capacity and higher reliability. Then in the 2000s, significant reduction in size and thickness were achieved, all while maintaining high precision specifications.



HarmonicDrive®

Sold & Serviced by:

 **ELECTROMATE**

Toll Free Phone: (877) SERV098
Toll Free Fax: (877) SERV099

www.electromate.com
sales@electromate.com



SHG/SHF Series

Component Set SHG/SHF

Features	080
Ordering Code	081
Technical data	
• Rating table	082
• Outline drawing and dimensions	084
• Positional accuracy	086
• Hysteresis loss	086
• Backlash	086
• Torsional stiffness	086
• Starting torque	087
• Backdriving torque	087
• Ratcheting torque	088
• Buckling torque	088
• No-load running torque	088
• Efficiency	090
Design guide	
• Lubrication	092
• Assembly tolerances	096
• Sealing	096
• Installation of the three basic elements	097

Features

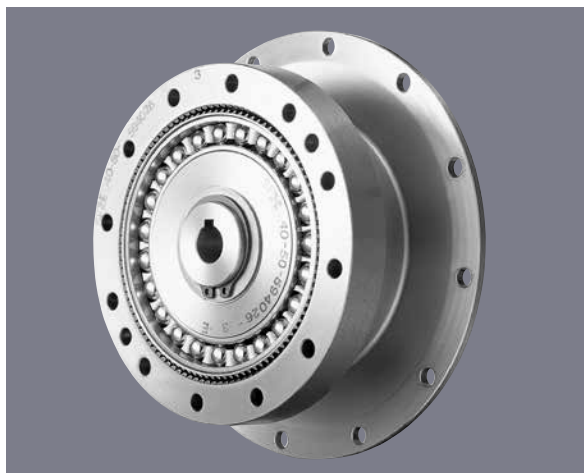

SHG/SHF series component set

The SHG/SHF series represents an advancement over the CSG/CSF series. While the basic performance of both series is the same, the SHG/SHF series offers additional features not offered in the CSG/CSF series. Key among those is the shape of the flexspline in the SHG/SHF series – it opens outward to form a brim that acts as a perfect mounting surface, while leaving a large through-hole.

The SHG/SHF component set consists of three basic parts – the wave generator, the flexspline, and the circular spline. These compact gears are extremely customizable and can be seamlessly integrated into your design.

Features

- Large hollow through bore
- Flat shape
- Zero backlash
- Compact and simple design
- High torque capacity
- High stiffness
- High positioning and rotational accuracies
- Coaxial input and output

Series

SHF: standard torque

- Reduction ratio of 30:1 added for high-speed

SHG: high torque

- 30% Higher torque than SHF series
- Improved life by 43% (10,000 hours) over SHF

Structure of SHG/SHF series component set

Fig. 080-1

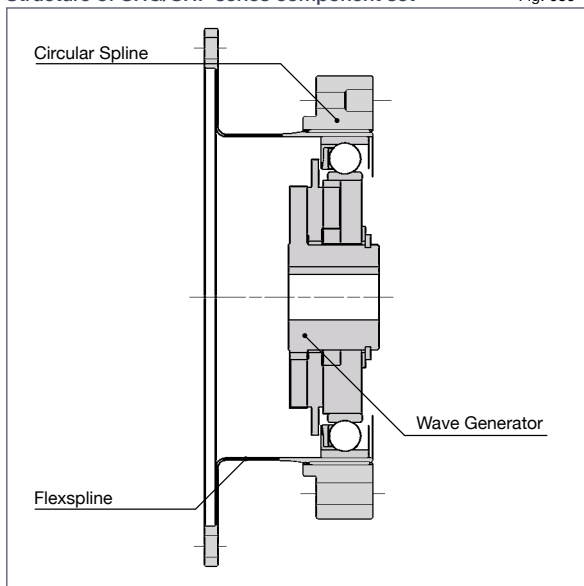

Comparison between SHG series and SHF series

Graph 080-1

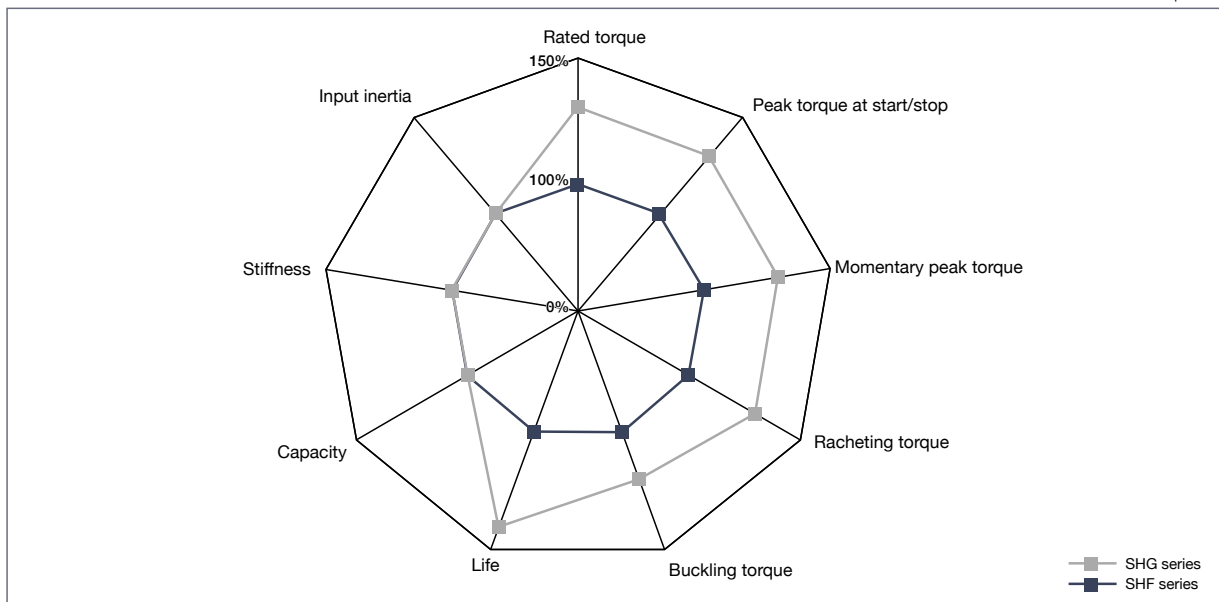

Ordering Code

SHG - 25 - 100 - 2A - GR - SP

Table 081-1

Series	Size	Ratio*						Model	Special specification
SHG High Torque	14	50	80	100	—	—	2A-GR= Component type (2A-R for size 14, 17)	SP= Special specification code Blank= Standard product	
	17	50	80	100	120	—			
	20	50	80	100	120	160			
	25	50	80	100	120	160			
	32	50	80	100	120	160			
	40	50	80	100	120	160			
	45	50	80	100	120	160			
	50	—	80	100	120	160			
	58	—	80	100	120	160			
	65	—	80	100	120	160			

* The reduction ratio value is based on the following configuration:
Input: wave generator, fixed: circular spline, output: flexspline

SHF - 25 - 100 - 2A - GR - SP

Table 081-2

Series	Size	Ratio*						Model	Special specification
SHF Standard Torque	14	30	50	80	100	—	—	2A-GR= Component type (2A-R for size 14, 17)	SP= Special specification code Blank= Standard product
	17	30	50	80	100	120	—		
	20	30	50	80	100	120	160		
	25	30	50	80	100	120	160		
	32	30	50	80	100	120	160		
	40	—	50	80	100	120	160		
	45	—	50	80	100	120	160		
	50	—	50	80	100	120	160		
	58	—	50	80	100	120	160		

* The reduction ratio value is based on the following configuration:
Input: wave generator, fixed: circular spline, output: flexspline

Engineering Data

Component Sets

Gear Units

Phase Adjusters

Gearheads & Actuators

Technical Data

Rating table

■ SHG series

Table 082-1

Size	Ratio	Rated Torque at 2000rpm		Limit for Repeated Peak Torque		Limit for Average Torque		Limit for Momentary Peak Torque		Maximum Input Speed (rpm)		Limit for Average Input Speed (rpm)		Moment of Inertia	
		Nm	kgfm	Nm	kgfm	Nm	kgfm	Nm	kgfm	Oil lubricant	Grease lubricant	Oil lubricant	Grease lubricant	I ×10 ⁴ kgm ²	J ×10 ⁴ kgfms ²
14	50	7.0	0.7	23	2.3	9	0.9	46	4.7	14000	8500	6500	3500	0.033	0.034
	80	10	1.0	30	3.1	14	1.4	61	6.2						
	100	10	1.0	36	3.7	14	1.4	70	7.2						
17	50	21	2.1	44	4.5	34	3.4	91	9	10000	7300	6500	3500	0.079	0.081
	80	29	2.9	56	5.7	35	3.6	113	12						
	100	31	3.2	70	7.2	51	5.2	143	15						
20	120	31	3.2	70	7.2	51	5.2	112	11	10000	6500	6500	3500	0.193	0.197
	50	33	3.3	73	7.4	44	4.5	127	13						
	80	44	4.5	96	9.8	61	6.2	165	17						
	100	52	5.3	107	10.9	64	6.5	191	20						
25	120	52	5.3	113	11.5	64	6.5	191	20	7500	5600	5600	3500	0.413	0.421
	50	51	5.2	127	13	72	7.3	242	25						
	80	82	8.4	178	18	113	12	332	34						
	100	87	8.9	204	21	140	14	369	38						
32	120	87	8.9	217	22	140	14	395	40	7000	4800	4600	3000	1.69	1.72
	50	99	10	281	29	140	14	497	51						
	80	153	16	395	40	217	22	738	75						
	100	178	18	433	44	281	29	841	86						
40	120	178	18	459	47	281	29	892	91	5600	4000	3600	3000	4.50	4.59
	50	178	18	484	49	281	29	892	91						
	80	178	18	523	53	255	26	892	91						
	100	268	27	675	69	369	38	1270	130						
45	120	345	35	738	75	484	49	1400	143	5000	3800	3300	3000	8.68	8.86
	160	382	39	802	82	586	60	1530	156						
	50	229	23	650	66	345	35	1235	126						
	80	407	41	918	94	507	52	1651	168						
50	100	459	47	982	100	650	66	2041	208	4500	3500	3000	2500	12.5	12.8
	120	523	53	1070	109	806	82	2288	233						
	160	523	53	1147	117	819	84	2483	253						
	80	484	49	1223	125	675	69	2418	247						
58	100	611	62	1274	130	866	88	2678	273	4000	3000	2700	2200	27.3	27.9
	120	688	70	1404	143	1057	108	2678	273						
	160	688	70	1534	156	1096	112	3185	325						
	80	714	73	1924	196	1001	102	3185	325						
65	100	905	92	2067	211	1378	141	4134	422	3500	2800	2400	1900	46.5	47.8
	120	969	99	2236	228	1547	158	4329	441						
	160	969	99	2392	244	1573	160	4459	455						
	80	969	99	2743	280	1352	138	4836	493						
65	100	1236	126	2990	305	1976	202	6175	630	3500	2800	2400	1900	46.5	47.8
	120	1236	126	3263	333	2041	208	6175	630						
	160	1236	126	3419	349	2041	208	6175	630						

(Note) 1. Moment of inertia: $I = \frac{1}{4}GD^2$
 2. See "Engineering data" on Page 12 for details of the terms.

SHF series

Table 083-1

Size	Ratio	Rated Torque at 2000rpm		Limit for Repeated Peak Torque		Limit for Average Torque		Limit for Momentary Peak Torque		Maximum Input Speed (rpm)		Limit for Average Input Speed (rpm)		Moment of Inertia	
		Nm	kgfm	Nm	kgfm	Nm	kgfm	Nm	kgfm	Oil lubricant	Grease lubricant	Oil lubricant	Grease lubricant	I x10 ⁴ kgm ²	J x10 ⁴ kgfms ²
14	30	4.0	0.41	9.0	0.92	6.8	0.69	17	1.7	14000	8500	6500	3500	0.033	0.034
	50	5.4	0.55	18	1.8	6.9	0.70	35	3.6						
	80	7.8	0.80	23	2.4	11	1.1	47	4.8						
	100	7.8	0.80	28	2.9	11	1.1	54	5.5						
17	30	8.8	0.90	16	1.6	12	1.2	30	3.1	10000	7300	6500	3500	0.079	0.081
	50	16	1.6	34	3.5	26	2.6	70	7.1						
	80	22	2.2	43	4.4	27	2.7	87	8.9						
	100	24	2.4	54	5.5	39	4.0	110	11						
	120	24	2.4	54	5.5	39	4.0	86	8.8						
20	30	15	1.5	27	2.8	20	2.0	50	5.1	10000	6500	6500	3500	0.193	0.197
	50	25	2.5	56	5.7	34	3.5	98	10						
	80	34	3.5	74	7.5	47	4.8	127	13						
	100	40	4.1	82	8.4	49	5.0	147	15						
	120	40	4.1	87	8.9	49	5.0	147	15						
	160	40	4.1	92	9.4	49	5.0	147	15						
25	30	27	2.8	50	5.1	38	3.9	95	9.7	7500	5600	5600	3500	0.413	0.421
	50	39	4.0	98	10	55	5.6	186	19						
	80	63	6.4	137	14	87	8.9	255	26						
	100	67	6.8	157	16	108	11	284	29						
	120	67	6.8	167	17	108	11	304	31						
	160	67	6.8	176	18	108	11	314	32						
32	30	54	5.5	100	10	75	7.7	200	20	7000	4800	4600	3500	1.69	1.72
	50	76	7.8	216	22	108	11	382	39						
	80	118	12	304	31	167	17	568	58						
	100	137	14	333	34	216	22	647	66						
	120	137	14	353	36	216	22	686	70						
	160	137	14	372	38	216	22	686	70						
40	50	137	14	402	41	196	20	686	70	5600	4000	3600	3000	4.50	4.59
	80	206	21	519	53	284	29	980	100						
	100	265	27	568	58	372	38	1080	110						
	120	294	30	617	63	451	46	1180	120						
	160	294	30	647	66	451	46	1180	120						
45	50	176	18	500	51	265	27	950	97	5000	3800	3300	3000	8.68	8.86
	80	313	32	706	72	390	40	1270	130						
	100	353	36	755	77	500	51	1570	160						
	120	402	41	823	84	620	63	1760	180						
	160	402	41	882	90	630	64	1910	195						
50	50	245	25	715	73	350	36	1430	146	4500	3500	3000	2500	12.5	12.8
	80	372	38	941	96	519	53	1860	190						
	100	470	48	980	100	666	68	2060	210						
	120	529	54	1080	110	813	83	2060	210						
	160	529	54	1180	120	843	86	2450	250						
58	50	353	36	1020	104	520	53	1960	200	4000	3000	2700	2200	27.3	27.9
	80	549	56	1480	151	770	79	2450	250						
	100	696	71	1590	162	1060	108	3180	325						
	120	745	76	1720	176	1190	121	3330	340						
	160	745	76	1840	188	1210	123	3430	350						

(Note) 1. Oil lubrication is standard for sizes 50 and over with gear ratio 50:1. If it is necessary to use grease, the rated torque is reduced by 50%.

2. Moment of inertia: $I = \frac{1}{4}GD^2$

3. See "Rating Table Definitions" on Page 12 for details of the terms.

Outline Dimensions

You can download the CAD files from our website: harmonicdrive.net

Fig. 084-1

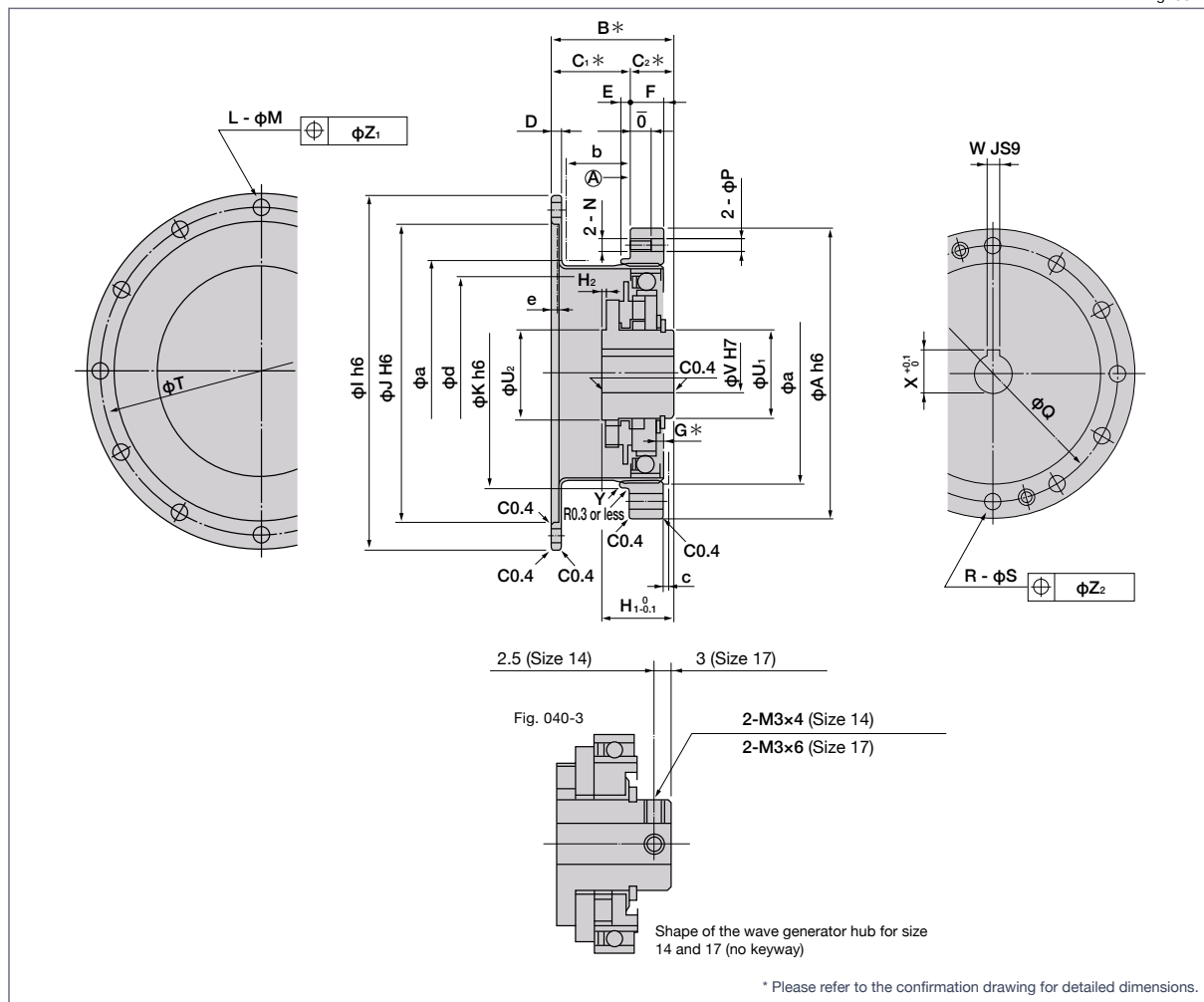

Wave generator components

The wave generator utilizes an Oldham coupling.

There is a difference in appearance of the the ball separator between SHF and SHG. SHG size 14, 17 and 65 use the same ball separator as SHF

Fig. 084-2

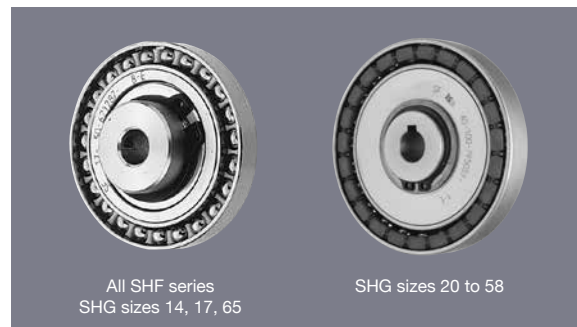
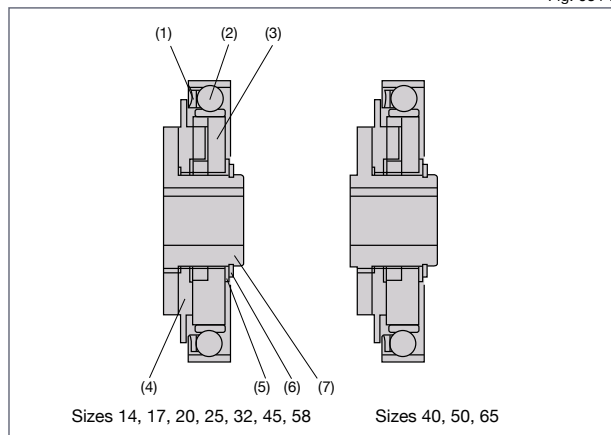

Dimensions

 Table 085-1
 Unit: mm

Symbol	Size	14	17	20	25	32	40	45	50	58	65
ϕA h6		50	60	70	85	110	135	155	170	195	215
B*	SHG Series	28.5 ⁰ _{-0.4}	32.5 ⁰ _{-0.4}	33.5 ⁰ _{-0.4}	37 ⁰ _{-0.5}	44 ⁰ _{-0.6}	53 ⁰ _{-0.6}	58.5 ⁰ _{-0.6}	64 ⁰ _{-0.7}	75.5 ⁰ _{-0.7}	83 ⁰ _{-0.7}
	SHF Series	28.5 ⁰ _{-0.8}	32.5 ⁰ _{-0.9}	33.5 ⁰ _{-1.0}	37 ⁰ _{-1.0}	44 ⁰ _{-1.1}	53 ⁰ _{-1.1}	58.5 ⁰ _{-1.2}	64 ⁰ _{-1.3}	75.5 ⁰ _{-1.3}	—
C ₁ *		17.5 ⁰ _{-0.4}	20 ⁰ _{-0.5}	21.5 ⁰ _{-0.8}	24 ⁰ _{-0.8}	28 ⁰ _{-0.8}	34 ⁰ _{-0.6}	38 ⁰ _{-0.6}	41 ⁰ _{-0.6}	48 ⁰ _{-0.6}	52.5 ⁰ _{-0.6}
C ₂ *		11	12.5	12	13	16	19	20.5	23	27.5	30.5
D		2.4	3	3	3.3	3.6	4	4.5	5	5.8	6.5
E		2	2.5	3	3	3	4	4	4	5	5
F		6	6.5	7.5	10	14	17	19	22	25	29
G*	SHG Series	1.4	1.6	1.5	3.5	4.2	5.6	6.3	7	8.2	9.5
	SHF Series	0.4	0.3	0.1	2.1	2.5	3.3	3.7	4.2	4.8	—
H ₁	SHG Series	18.5 ⁰ _{-0.1}	20.7 ⁰ _{-0.1}	21.5 ⁰ _{-0.1}	21.6 ⁰ _{-0.1}	23.6 ⁰ _{-0.1}	29.7 ⁰ _{-0.1}	30.5 ⁰ _{-0.1}	34.8 ⁰ _{-0.1}	38.3 ⁰ _{-0.1}	44.6 ⁰ _{-0.1}
	SHF Series	17.6 ⁰ _{-0.1}	19.5 ⁰ _{-0.1}	20.1 ⁰ _{-0.1}	20.2 ⁰ _{-0.1}	22 ⁰ _{-0.1}	27.5 ⁰ _{-0.1}	27.9 ⁰ _{-0.1}	32 ⁰ _{-0.1}	34.9 ⁰ _{-0.1}	—
H ₂		—	—	—	—	—	0.4	—	0.8	—	2.2
ϕI h6	SHG Series	60	72	82	104	134	164	190	214	240	276
	SHF Series	60	72	82	104	134	164	182	205	233	—
ϕJ H6		48	60	70	88	114	140	158	175	203	232
ϕK h6	Ratios > 30:1	38	48	54	67	90	110	124	135	156	177
	Ratio 30:1	38	48	55	68	90	—	—	—	—	—
L		8	12	12	12	12	12	18	12	16	16
ϕM		3.5	3.4	3.5	4.5	5.5	6.6	6.6	9	9	11
N		M3	M3	M3	M4	M5	M6	M8	M8	M10	M10
O		6	6.5	4	6	7	9	12	13	15	15
ϕP		—	—	3.5	4.5	5.5	6.6	9	9	11	11
ϕQ		44	54	62	75	100	120	140	150	175	195
R	SHG Series	8	16	16	16	16	16	16	16	16	16
	SHF Series	6	12	12	12	12	12	12	12	12	—
ϕS		3.5	3.5	3.5	4.5	5.5	6.6	9	9	11	11
ϕT	SHG Series	54	66	76	96	124	152	180	200	226	258
	SHF Series	54	66	76	96	124	152	170	190	218	—
ϕU_1		14	18	21	26	26	32	32	32	40	48
ϕU_2		—	—	—	—	—	32	—	32	—	48
ϕV	Standard (H7)	6	8	9	11	14	14	19	19	22	24
	Max. size (H7)	8	10	13	15	15	20	20	20	25	30
WJs9		—	—	3	4	5	5	6	6	6	8
X		—	—	10.4 ^{+0.1}	12.8 ^{+0.1}	16.3 ^{+0.1}	16.3 ^{+0.1}	21.8 ^{+0.1}	21.8 ^{+0.1}	24.8 ^{+0.1}	27.3 ^{+0.2}
Y		C0.3	C0.4	C0.4	C0.4	C0.4	C0.4	C0.4	C0.8	C0.8	C0.8
ϕZ_1		0.25	0.20	0.25	0.25	0.25	0.3	0.3	0.5	0.5	0.5
ϕZ_2		0.25	0.25	0.25	0.25	0.25	0.3	0.5	0.5	0.5	0.5
Minimum housing clearance	ϕa	38	45	53	66	86	106	119	133	154	172
	b	14.6	16.4	17.8	19.8	23.2	28.6	31.9	34.2	40.1	43
	c	1	1	1.5	1.5	1.5	2	2	2	2.5	2.5
	ϕd	31	38	45	56	73	90	101	113	131	150
	e	1.7	2.1	2.0	2.0	2.0	2.0	2.3	2.5	2.9	3.5
Mass (kg)		0.11	0.18	0.31	0.48	0.97	1.87	2.64	3.53	5.17	7.04

- The clamp face of the circular spline is Face (A) in the drawing. Fit this face to install it on the case.
- The following dimensions can be modified to accommodate customer-specific requirements.
 Wave Generator : V
 Flexspline : L and M
 Circular Spline : R and S
- Since some dimensions are different between SHF series and SHG series, pay careful attention during installation.

- *B, C₁, C₂ and G values indicate relative position of individual gearing components (wave generator, flexspline, circular spline). Please strictly adhere to these values when designing your housing and mating parts.
- Due to the deformation of the Flexspline during operation, it is necessary to provide a minimum housing clearance, dimensions ϕa , b, c, and it should not exceed ϕd and e to prevent possible contact with the housing.

The wave generator, flexspline, and circular spline are not assembled when delivered.

Positional accuracy

See "Engineering data" for a description of terms.

Table 086-1

Ratio	Specification	Size	14	17	20	25	32	40 to 65
30	Standard product	x10 ⁻⁴ rad	5.8	4.4	4.4	4.4	4.4	—
		arc min	2	1.5	1.5	1.5	1.5	—
	Special product	x10 ⁻⁴ rad	—	—	2.9	2.9	2.9	—
		arc min	—	—	1	1	1	—
50 or more	Standard product	x10 ⁻⁴ rad	4.4	4.4	2.9	2.9	2.9	2.9
		arc min	1.5	1.5	1	1	1	1
	Special product	x10 ⁻⁴ rad	2.9	2.9	1.5	1.5	1.5	1.5
		arc min	1	1	0.5	0.5	0.5	0.5

Hysteresis loss

See "Engineering data" for a description of terms.

Table 086-2

Ratio	Unit	Size	14	17	20	25	32	40 or more
30		x10 ⁻⁴ rad	8.7	8.7	8.7	8.7	8.7	—
		arc min	3.0	3.0	3.0	3.0	3.0	—
50		x10 ⁻⁴ rad	5.8	5.8	5.8	5.8	5.8	5.8
		arc min	2.0	2.0	2.0	2.0	2.0	2.0
80 or more		x10 ⁻⁴ rad	2.9	2.9	2.9	2.9	2.9	2.9
		arc min	1.0	1.0	1.0	1.0	1.0	1.0

Backlash

See "Engineering data" for a description of terms.

Table 086-3

Ratio	Size	14	17	20	25	32	40	45	50	58	65
30	x10 ⁻⁴ rad	29.1	16.0	13.6	13.6	11.2	—	—	—	—	—
	arc sec	60	33	28	28	23	—	—	—	—	—
50	x10 ⁻⁴ rad	17.5	9.7	8.2	8.2	6.8	6.8	5.8	5.8	4.8	—
	arc sec	36	20	17	17	14	14	12	12	10	—
80	x10 ⁻⁴ rad	11.2	6.3	5.3	5.3	4.4	4.4	3.9	3.9	2.9	2.9
	arc sec	23	13	11	11	9	9	8	8	6	6
100	x10 ⁻⁴ rad	8.7	4.8	4.4	4.4	3.4	3.4	2.9	2.9	2.4	2.4
	arc sec	18	10	9	9	7	7	6	6	5	5
120	x10 ⁻⁴ rad	—	3.9	3.9	3.9	2.9	2.9	2.4	2.4	1.9	1.9
	arc sec	—	8	8	8	6	6	5	5	4	4
160	x10 ⁻⁴ rad	—	—	2.9	2.9	2.4	2.4	1.9	1.9	1.5	1.5
	arc sec	—	—	6	6	5	5	4	4	3	3

Torsional stiffness

See "Engineering data" for a description of terms.

Table 086-4

Symbol	Size	14	17	20	25	32	40	45	50	58	65		
T ₁	Nm	2.0	3.9	7.0	14	29	54	76	108	168	235		
	kgfm	0.2	0.4	0.7	1.4	3.0	5.5	7.8	11	17	24		
T ₂	Nm	6.9	12	25	48	108	196	275	382	598	843		
	kgfm	0.7	1.2	2.5	4.9	11	20	28	39	61	86		
Reduction ratio 30	K ₁	x10 ⁻⁴ Nm/rad	0.19	0.34	0.57	1.0	2.4	—	—	—	—	—	
		kgf·m/arc min	0.056	0.10	0.17	0.30	0.70	—	—	—	—	—	
	K ₂	x10 ⁻⁴ Nm/rad	0.24	0.44	0.71	1.3	3.0	—	—	—	—	—	
		kgfm/arc min	0.07	0.13	0.21	0.40	0.89	—	—	—	—	—	
	K ₃	x10 ⁻⁴ Nm/rad	0.34	0.67	1.1	2.1	4.9	—	—	—	—	—	
		kgfm/arc min	0.10	0.20	0.32	0.62	1.5	—	—	—	—	—	
	θ ₁	x10 ⁻⁴ rad	10.5	11.5	12.3	14	12.1	—	—	—	—	—	
		arc min	3.6	4.0	4.1	4.7	4.3	—	—	—	—	—	
	θ ₂	x10 ⁻⁴ rad	31	30	38	40	38	—	—	—	—	—	
		arc min	10.7	10.2	12.7	13.4	13.3	—	—	—	—	—	
	Reduction ratio 50	K ₁	x10 ⁻⁴ Nm/rad	0.34	0.81	1.3	2.5	5.4	10	15	20	31	—
			kgfm/arc min	0.1	0.24	0.38	0.74	1.6	3.0	4.3	5.9	9.3	—
		K ₂	x10 ⁻⁴ Nm/rad	0.47	1.1	1.8	3.4	7.8	14	20	28	44	—
			kgfm/arc min	0.14	0.32	0.52	1.0	2.3	4.2	6.0	8.2	13	—
K ₃		x10 ⁻⁴ Nm/rad	0.57	1.3	2.3	4.4	9.8	18	26	34	54	—	
		kgfm/arc min	0.17	0.4	0.67	1.3	2.9	5.3	7.6	10	16	—	
θ ₁		x10 ⁻⁴ rad	5.8	4.9	5.2	5.5	5.5	5.2	5.2	5.5	5.2	—	
		arc min	2.0	1.7	1.8	1.9	1.9	1.8	1.8	1.9	1.8	—	
θ ₂		x10 ⁻⁴ rad	16	12	15.4	15.7	15.7	15.4	15.1	15.4	15.1	—	
		arc min	5.6	4.2	5.3	5.4	5.4	5.3	5.2	5.3	5.2	—	

* The values in this table are reference values. The minimum value is approximately 80% of the displayed value.

Table 087-1

Symbol		Size	14	17	20	25	32	40	45	50	58	65
T ₁	Nm		2.0	3.9	7.0	14	29	54	76	108	168	235
	kgfm		0.2	0.4	0.7	1.4	3.0	5.5	7.8	11	17	24
T ₂	Nm		6.9	12	25	48	108	196	275	382	598	843
	kgfm		0.7	1.2	2.5	4.9	11	20	28	39	61	86
Reduction ratio 80 or more	K ₁	x10°Nm/rad	0.47	1	1.6	3.1	6.7	13	18	25	40	54
		kgfm/arc min	0.14	0.3	0.47	0.92	2.0	3.8	5.4	7.4	12	16
	K ₂	x10°Nm/rad	0.61	1.4	2.5	5.0	11	20	29	40	61	88
		kgfm/arc min	0.18	0.4	0.75	1.5	3.2	6.0	8.5	12	18	26
	K ₃	x10°Nm/rad	0.71	1.6	2.9	5.7	12	23	33	44	71	98
		kgfm/arc min	0.21	0.46	0.85	1.7	3.7	6.8	9.7	13	21	29
	θ ₁	x10°rad	4.1	3.9	4.4	4.4	4.4	4.1	4.1	4.4	4.1	4.4
		arc min	1.4	1.3	1.5	1.5	1.5	1.4	1.4	1.5	1.4	1.5
	θ ₂	x10°rad	12	9.7	11.3	11.1	11.6	11.1	11.1	11.1	11.1	11.1
		arc min	4.2	3.3	3.9	3.8	4.0	3.8	3.8	3.8	3.8	3.9

* The values in this table are reference values. The minimum value is approximately 80% of the displayed value.

Starting torque

See "Engineering data" for a description of terms. Please use as reference values; the values vary based on use conditions.

Table 087-2
Unit: Ncm

SHG series

Ratio	Size	14	17	20	25	32	40	45	50	58	65
30		4.8	7.2	12	18	50	—	—	—	—	—
50		3.7	5.7	7.3	14	28	50	70	94	140	—
80		2.8	3.8	4.8	8.9	19	33	47	63	94	128
100		2.4	3.3	4.3	7.9	18	29	41	56	83	114
120		—	3.1	3.9	7.3	15	27	37	51	76	104
160		—	—	3.4	6.4	14	24	33	44	68	94

SHF series

Table 087-3
Unit: Ncm

Ratio	Size	14	17	20	25	32	40	45	50	58
30		4.8	7.2	12	18	50	—	—	—	—
50		3.7	5.7	7.3	14	28	50	70	94	140
80		2.8	3.8	4.8	8.9	19	33	47	63	94
100		2.4	3.3	4.3	7.9	18	29	41	56	83
120		—	3.1	3.9	7.3	15	27	37	51	76
160		—	—	3.4	6.4	14	24	33	44	68

Backdriving torque

See "Engineering data" for a description of terms. Please use as reference values; the values vary based on use conditions.

Table 087-4
Unit: Nm

SHG series

Ratio	Size	14	17	20	25	32	40	45	50	58	65
30		2.3	3.5	6.1	11	23	—	—	—	—	—
50		2.2	3.4	4.4	8.2	17	30	42	56	84	—
80		2.7	3.7	4.6	8.6	18	32	45	60	90	123
100		2.8	4	5.2	9.5	21	35	49	67	100	137
120		—	4.5	5.6	10	21	40	54	73	110	151
160		—	—	6.6	12	26	45	64	85	130	180

SHF series

Table 087-5
Unit: Nm

Ratio	Size	14	17	20	25	32	40	45	50	58
30		2.3	3.5	6.1	11	23	—	—	—	—
50		2.2	3.4	4.4	8.2	17	30	42	56	84
80		2.7	3.7	4.6	8.6	18	32	45	60	90
100		2.8	4	5.2	9.5	21	35	49	67	100
120		—	4.5	5.6	10	21	40	54	73	110
160		—	—	6.6	12	26	45	64	85	130

Ratcheting torque

See "Engineering data" for a description of terms.

Table 088-1

SHG series

Unit: Nm

Ratio \ Size	14	17	20	25	32	40	45	50	58	65
50	110	190	280	580	1200	2300	3500	—	—	—
80	140	260	450	880	1800	3600	5000	7000	10000	14000
100	100	200	330	650	1300	2700	4000	5300	8300	12000
120	—	150	310	610	1200	2400	3600	4900	7500	10000
160	—	—	280	580	1200	2300	3300	4600	7200	10000

Table 088-2

SHF series

Unit: Nm

Ratio \ Size	14	17	20	25	32	40	45	50	58
30	59	100	170	340	720	—	—	—	—
50	88	150	220	450	980	1800	2700	3700	5800
80	110	200	350	680	1400	2800	3900	5400	8200
100	84	160	260	500	1000	2100	3100	4100	6400
120	—	120	240	470	980	1900	2800	3800	5800
160	—	—	220	450	980	1800	2600	3600	5600

Buckling torque

See "Engineering data" for a description of terms.

Table 088-3

SHG series

Unit: Nm

Size	14	17	20	25	32	40	45	50	58	65
All ratios	210	420	700	1300	2800	5200	7600	10400	16200	22800

Table 088-4

SHF series

Unit: Nm

Size	14	17	20	25	32	40	45	50	58
All ratios	140	270	440	890	1750	3750	5400	7500	11800

No-load running torque

No-load running torque is the torque which is required to rotate the input side (high speed side), when there is no load on the output side (low speed side).

*Contact us for detailed values

Measurement condition

Table 088-5

Reduction ratio			
Lubricant	Grease lubrication	Name	Harmonic Grease SK-1A
			Harmonic Grease SK-2
		Quantity	Recommended quantity (See page 92)
Torque value is measured after 2 hours at 2000rpm input.			

* Contact us for oil lubrication.

■ Compensation Value in Each Ratio

No-load running torque of the gear varies with ratio. The graphs indicate a value for ratio 100. For other gear ratios, add the compensation values from the table on the right.

No-load running torque compensation values.

Table 089-1
Unit: Ncm

Ratio \ Size	30	50	80	120	160
14	+1.2	+0.5	+0.1	—	—
17	+2.1	+0.9	+0.1	-0.1	—
20	+3.1	+1.4	+0.2	-0.2	-0.4
25	+5.7	+2.5	+0.4	-0.3	-0.7
32	+11.7	+5.2	+0.8	-0.6	-1.4
40	—	+9.2	+1.4	-1.0	-2.5
45	—	+12.7	+2.0	-1.4	-3.5
50	—	+17.0	+2.6	-1.9	-4.6
58	—	+25.8	+4.0	-2.9	-7.0
65	—	—	+5.4	-4.0	-9.7

■ No-load running torque for a reduction ratio of 100

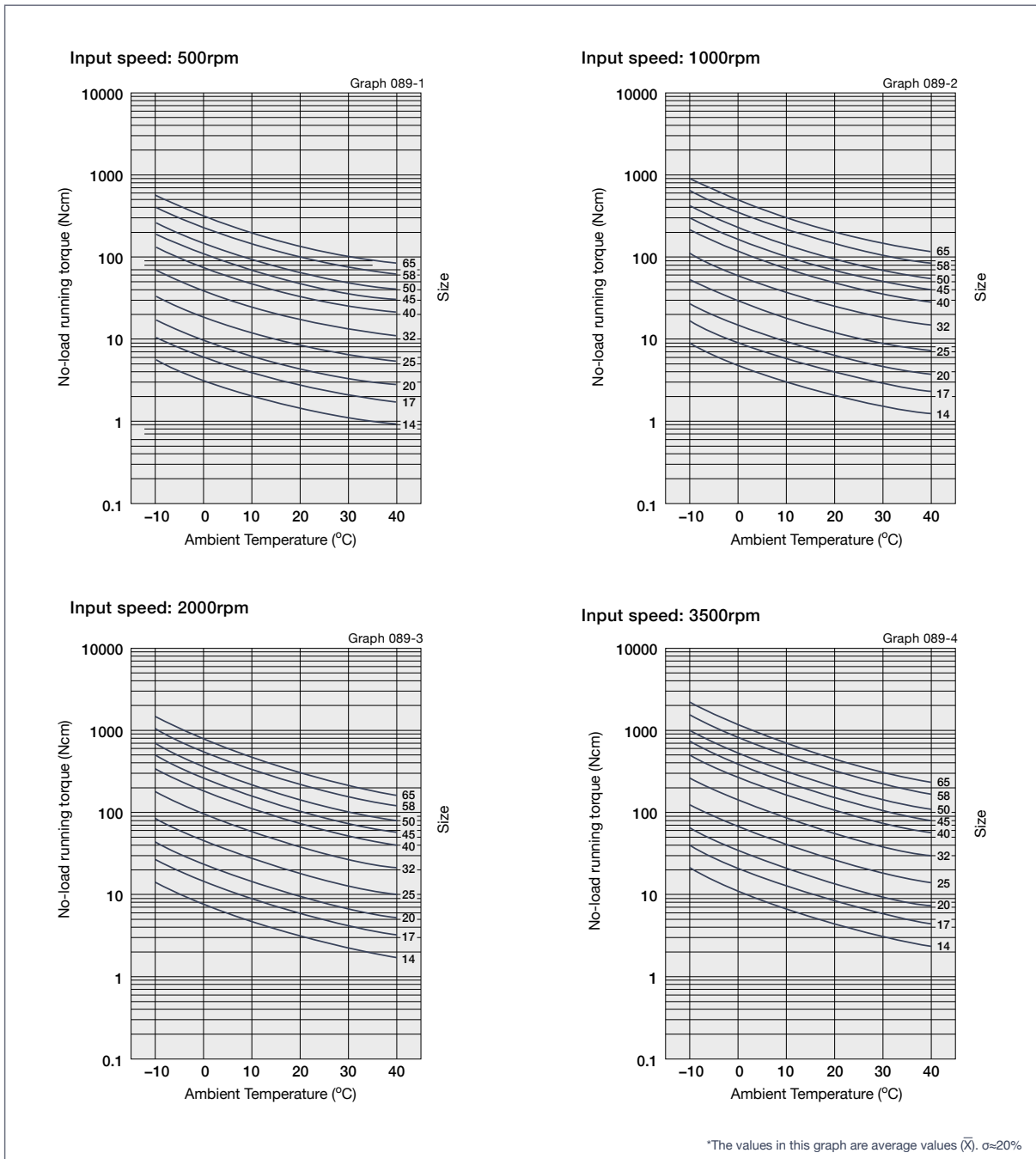

*The values in this graph are average values (\bar{X}). $\sigma \approx 20\%$

Efficiency

The efficiency varies depending on the following conditions.

- Reduction ratio
- Input rotational speed
- Load torque
- Temperature
- Lubrication (Type and quantity)

Measurement condition

Table 090-1

Installation	Based on recommended tolerance.		
Load torque	The rated torque shown in the rating table (see page 82 and 83)		
Lubricant	Grease lubrication	Name	Harmonic Grease SK-1A
		Quantity	Harmonic Grease SK-2 Recommended quantity (see page 92)

* Contact us for oil lubrication.

Efficiency compensation coefficient

If the load torque is lower than the rated torque, the efficiency value lowers. Calculate the compensation coefficient K_e from Graph 090-1 to calculate the efficiency using the following example.

Calculation Example

Efficiency η (%) under the following condition is calculated from the example of SHF-20-80-2A-GR.

Input rotational speed: 1000 rpm

Load torque: 19.6 Nm

Lubrication: Grease lubrication (Harmonic Grease SK-1A)

Lubricant temperature: 20°C

Since the rated torque of size 20 with a reduction ratio of 80 is 34 Nm (ratings: Page 83), the torque ratio α is 0.58.

($\alpha=19.6/34=0.58$)

- The efficiency compensation coefficient is $K_e=0.93$ from Graph 090-1.
- Efficiency η at load torque 19.6 Nm: $\eta=K_e \cdot \eta_R=0.93 \times 82=76\%$

Efficiency compensation coefficient

Graph 090-1

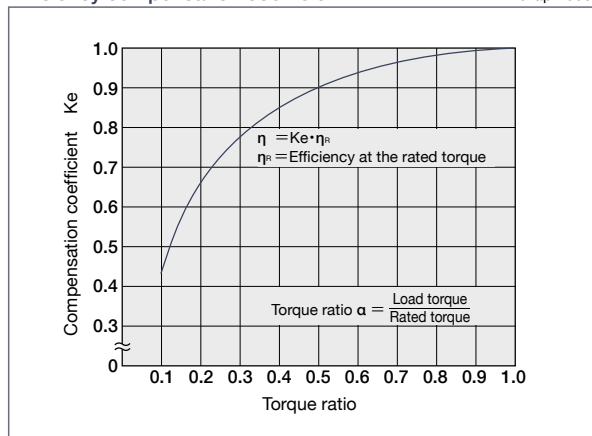

* Efficiency compensation coefficient $K_e=1$ holds when the load torque is greater than the rated torque.

Efficiency at rated torque

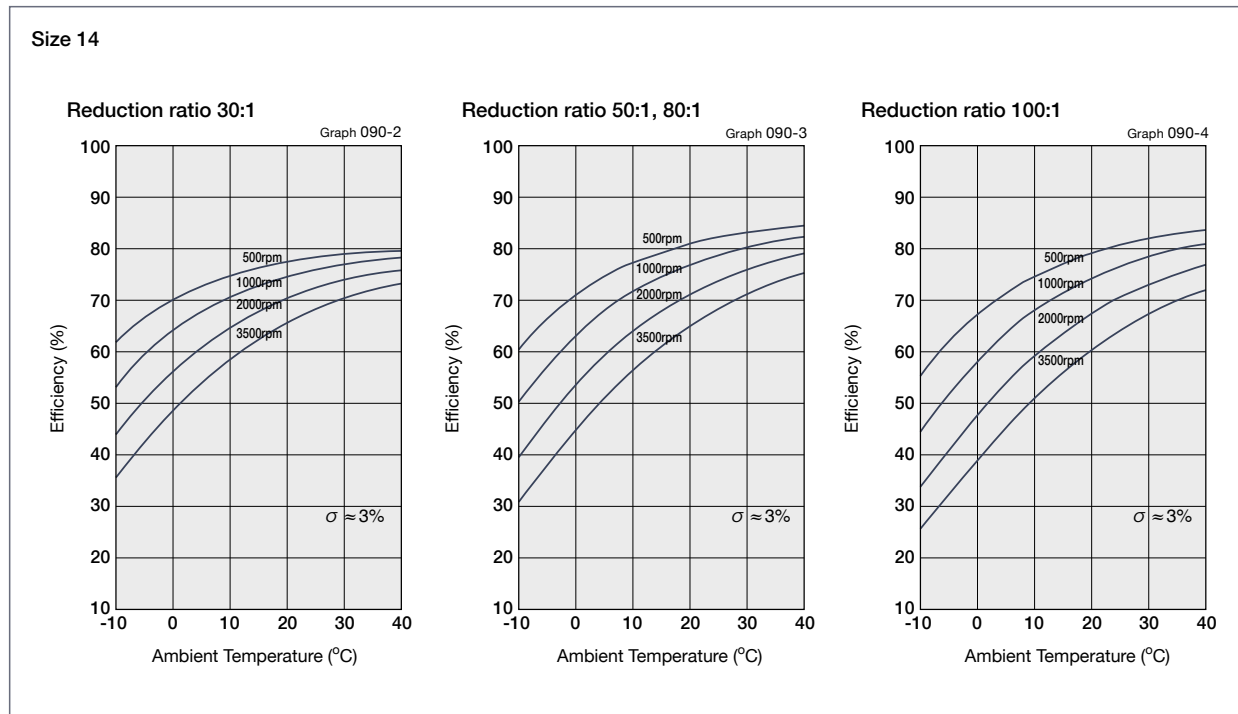

■ Efficiency at rated torque

Size 17 to 65

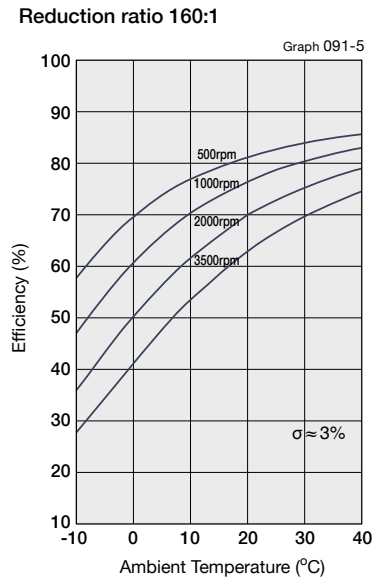
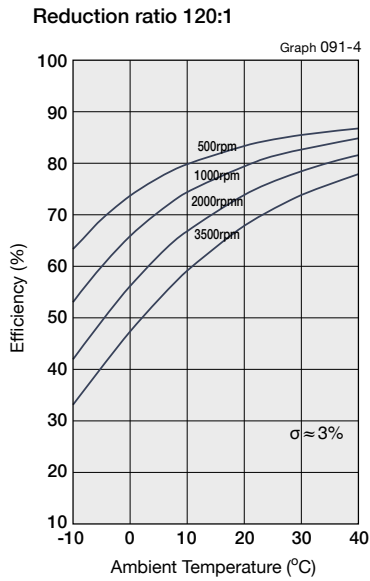
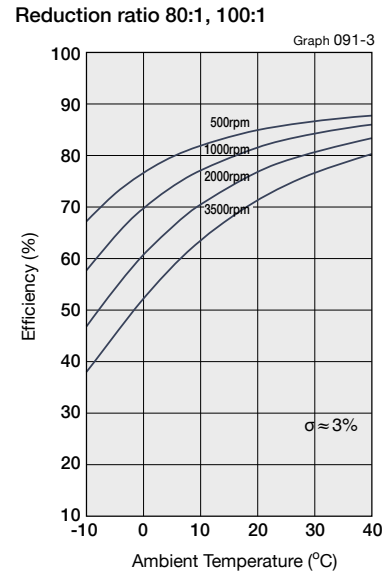
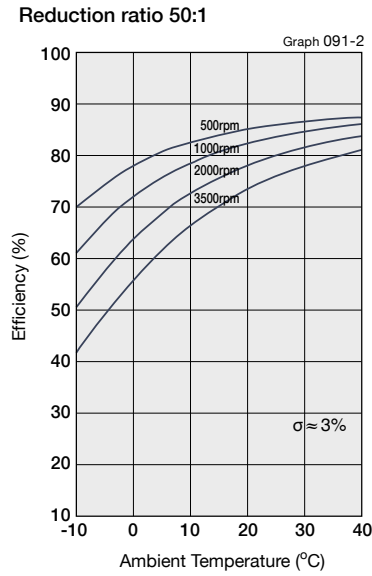
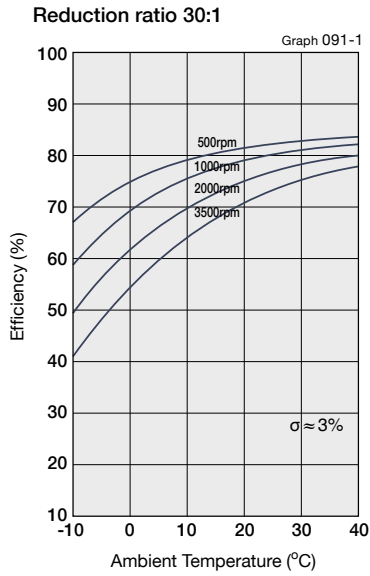

Design Guide

Lubrication

■ Grease lubrication*

See "Engineering data" on Page 16 for details of the lubricant.

Recommended housing dimensions

See table below for recommended housing dimensions. These dimensions must be maintained to prevent damage to the gear and to maintain a proper grease cavity.

Recommended housing dimensions

Fig. 092-1

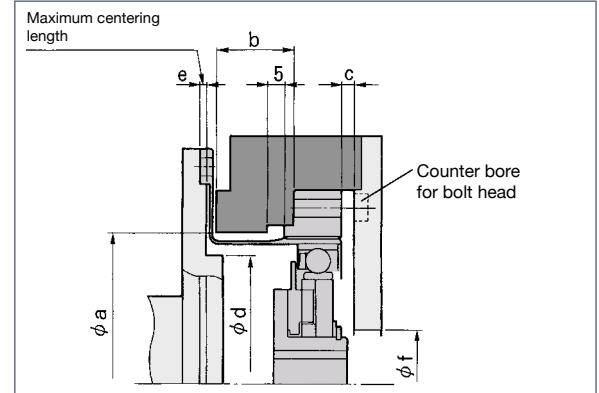

Recommended housing dimensions

Table 092-1
Unit: mm

Symbol \ Size	14	17	20	25	32	40	45	50*	58*	65*
ϕa	38	45	53	66	86	106	119	133	154	172
b	14.6	16.4	17.8	19.8	23.2	28.6	31.9	34.2	40.1	43
c	1 (3)	1 (3)	1.5 (4.5)	1.5 (4.5)	1.5 (4.5)	2 (6)	2 (6)	2 (6)	2.5 (7.5)	2.5 (7.5)
ϕd	31	38	45	56	73	90	101	113	131	150
e	1.7	2.1	2.0	2.0	2.0	2.0	2.3	2.5	2.9	3.5
$\phi f \begin{smallmatrix} +0.5 \\ 0 \end{smallmatrix}$	16	26	30	37	37	45	45	45	56	62

(Note) The value in parenthesis is the value when the wave generator is facing upward (see Figure 094-2 on Page 94).

* Oil lubrication is required for component-sets size 50 or larger with a reduction ratio of 50:1.

Application guide

Fig. 092-2

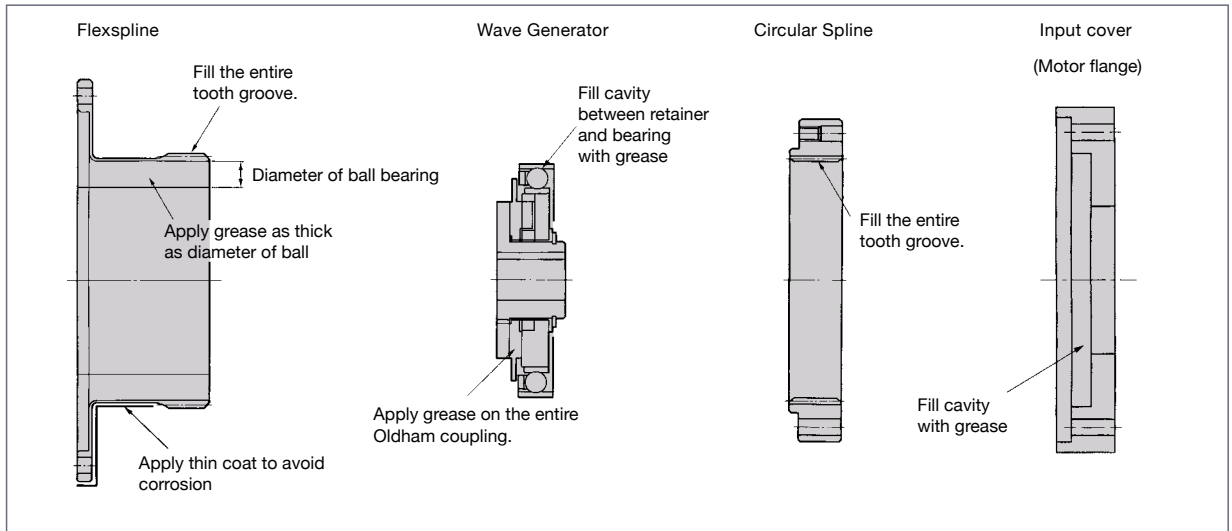

Application guide by usage

When the wave generator is facing upward or downward, refer to the next page for application guide.

Application guide by usage

Fig. 093-1

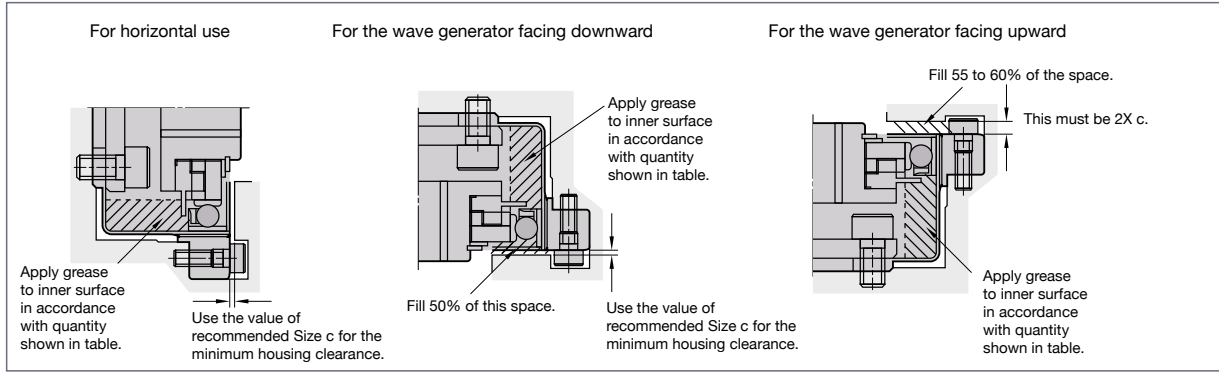

Application quantity

Table 093-1
Unit: g

Usage	Size	14	17	20	25	32	40	45	50	58	65
Horizontal use		5.8	11	18	32	64	120	185	235	385	495
Vertical use	Output shaft facing upward	7.5	13	19	37	74	130	200	255	400	530
	Output shaft facing downward	8.9	15	22	42	84	150	230	290	480	630

When to replace grease

The wear characteristics of the gear are strongly influenced by the condition of the grease lubrication. The condition of the grease is affected by the ambient temperature. The graph shows the maximum number of input rotations for various temperatures. This graph applies to applications where the average load torque does not exceed the rated torque. In cases where the rated torque is exceeded, calculate the grease change interval using the equation shown below.

When to replace grease: L_{GTn} (when the average load torque is equal to or less than the rated torque)

Graph 093-1

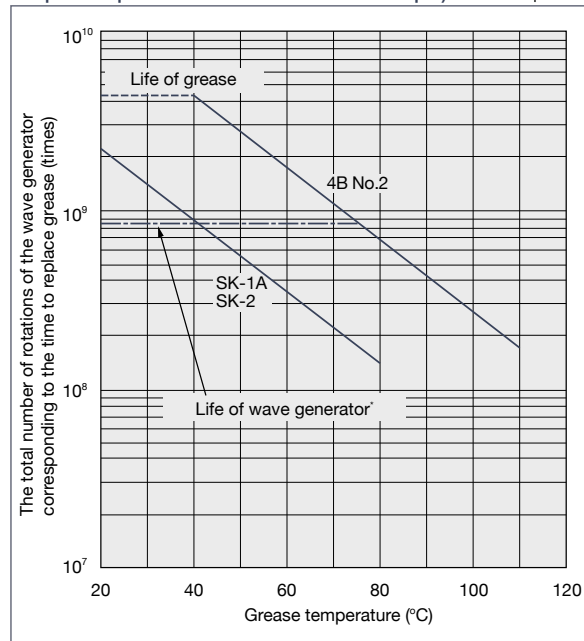

* Life of wave generator is based on L10 life of the bearing.

Formula when load torque exceeds rated torque

Formula 093-1

$$L_{GT} = L_{GTn} \times \left(\frac{T_r}{T_{av}} \right)^3$$

Symbols for Formula

Table 093-2

Symbol	Description	Unit	Reference
L_{GT}	Replacement timing if average load torque exceeds rated torque	Number of input revolutions	—
L_{GTn}	Replacement timing if average load torque is equal to or less than rated torque (or use formulas, i.e. $T_{av} \leq T_r$)	Number of input revolutions	See the right-hand figure.
T_r	Rated torque	Nm	See the "Rating table" on page 82 and 83.
T_{av}	Average load torque	Nm	Calculation formula: See Page 14.

Other precautions

1. Avoid using it with other grease. The gear should be in an individual case when installed.
2. If you use the gear with the wave generator facing upward (see Figure 050-2 on Page 50) at low-speed rotation (input rotational speed: 1000 rpm or less) and in one direction, please contact us as it may cause lubrication problems.
3. Oil lubrication is required for component-sets size 50 or larger with a reduction ratio of 50:1. Use grease lubrication within half the rated torque.

Oil lubrication

See "Engineering data" on Page 18 for details of the lubricant.

Usage and oil level

For horizontal installation

Oil level should be maintained at the level "A" as shown.

Oil level for horizontal use

Table 094-1
Unit: mm

Size	14	17	20	25	32	40	45	50	58	65
A	10	12	14	17	24	31	35	38	44	50

For vertical installation

Fill the center of the ball of the wave generator facing upward or downward with oil (Size B of Figure 094-2). An oil groove should be added to the flexspline. Inform us when you place an order.

Oil level for vertical use

Table 094-2
Unit: mm

Size	14	17	20	25	32	40	45	50	58	65
B	2.5	3	3	5	7	9	10	12	13	15

Oil level for horizontal use

Fig. 094-1

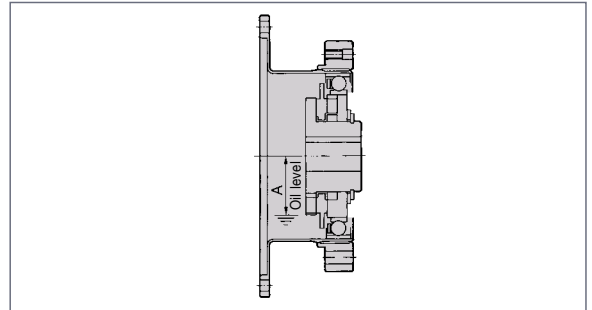

Oil level for vertical use

Fig. 094-2

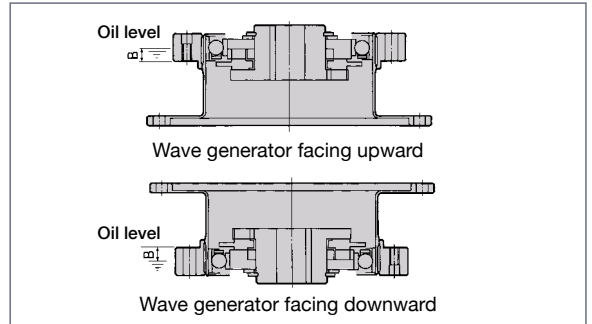

Example of Oil Channeling to the Flexspline Interface

When using oil as lubrication, the flange connected to the Flexspline must have a passage for oil to flow through. This allows for proper oil circulation.

Fig. 094-3

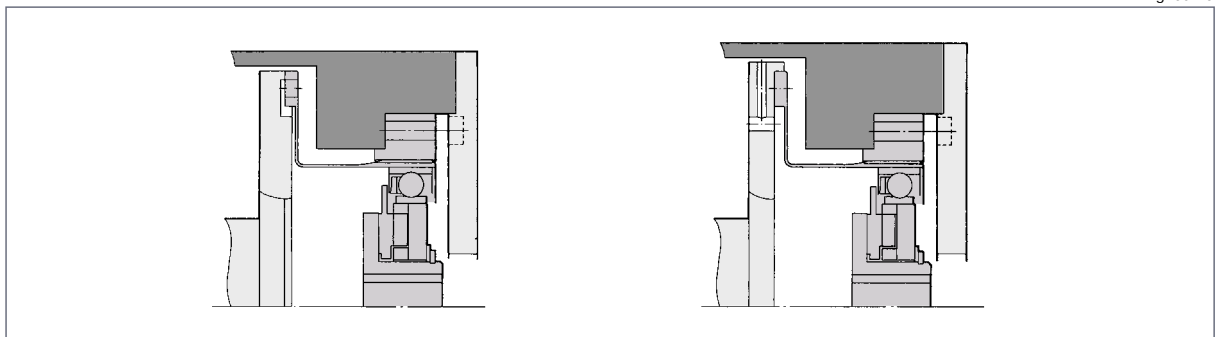

Oil quantity

Table 095-1
Unit: ℓ

Size	14	17	20	25	32	40	45	50	58	65
Amount	0.01	0.02	0.03	0.07	0.13	0.25	0.32	0.4	0.7	1.0

When to replace oil

First time100 hours after starting operation
 Second time or laterEvery 1000 operation hours or every 6 months
 Note that you should replace oil earlier than specified if the operating conditions are demanding.

Other precautions

Avoid mixing different kinds of oil. The gear should be in an individual case when installed.

Recommended tolerances for assembly

For peak performance of the gear, it is essential that the following tolerances be observed when assembly is complete. Pay careful attention to the following points and maintain the recommended assembly tolerances to avoid grease leakage.

- Warping and deformation on the mounting surface
- Contamination due to foreign matter
- Burrs, raised surfaces and location around the tap area of the mounting holes
- Insufficient chamfering on the mounting pilot joint
- Insufficient radii on the mounting pilot joint

Recommended Tolerances for Assembly

Fig. 096-1

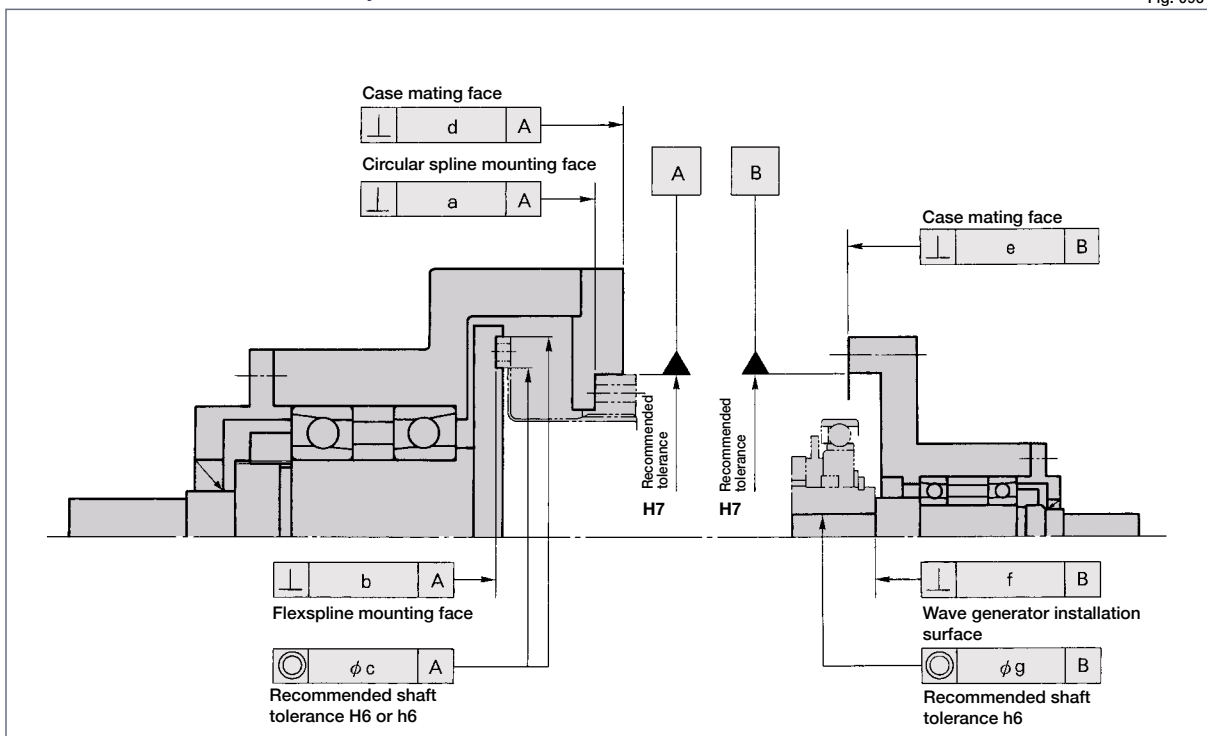

Recommended Tolerances for Assembly

Table 096-1
Unit: mm

Symbol	Size	14	17	20	25	32	40	45	50	58	65
a		0.011	0.012	0.013	0.014	0.016	0.016	0.017	0.018	0.020	0.023
b		0.016	0.021	0.027	0.035	0.042	0.048	0.053	0.057	0.062	0.067
φc		0.015	0.018	0.019	0.022	0.022	0.024	0.027	0.030	0.032	0.035
d		0.011	0.015	0.017	0.024	0.026	0.026	0.027	0.028	0.031	0.034
e		0.011	0.015	0.017	0.024	0.026	0.026	0.027	0.028	0.031	0.034
f		0.017 (0.008)	0.020 (0.010)	0.024 (0.012)	0.024 (0.012)	0.024 (0.012)	0.032 (0.012)	0.032 (0.013)	0.032 (0.015)	0.032 (0.015)	0.032 (0.015)
φg		0.030 (0.016)	0.034 (0.018)	0.044 (0.019)	0.047 (0.022)	0.050 (0.022)	0.063 (0.024)	0.065 (0.027)	0.066 (0.030)	0.068 (0.033)	0.070 (0.035)

(Note) The value in the parentheses indicates a solid wave generator (without Oldham's coupling structure).

Sealing

Sealing is needed to maintain the high durability of the gear and prevent grease leakage. Rotating parts should have an oil seal (with spring), surface should be smooth (no scratches). Mating flanges should have an O Ring, seal adhesive. Screws should have a thread lock (LOCTITE® 242 recommended) or seal adhesive. (Note) If you use Harmonic Grease® 4BNo.2, strict sealing is required.

Installation of three basic elements

■ Installation of the wave generator

1. Maximum hole diameter size

Hole diameter of the wave generator hub with Oldham coupling

Table 097-1
Unit: mm

Item \ Size	14	17	20	25	32	40	45	50	58	65
Stand. dimension (H7)	6	8	9	11	14	14	19	19	22	24
Minimum size (φ)	3	4	5	6	6	10	10	10	13	16
Maximum size (φ)	8	10	13	15	15	20	20	20	25	30

The standard hole dimension of the Wave Generator for each size is shown. The dimension can be changed within a range up to the maximum hole dimension shown in table 097-2. We recommend the dimension of keyway based on JIS standard. It is necessary that the dimension of keyways should sustain the transmission torque.

* Please note: Tapered holes are also available.

In cases where a larger hole is required, use the Wave Generator without the Oldham coupling. The maximum diameter of the hole should be considered to prevent deformation of the Wave Generator plug by load torque.

The dimensions shown in table 097-2 include the keyway.

Hole diameter of the wave generator with Oldham coupling

Fig. 097-1

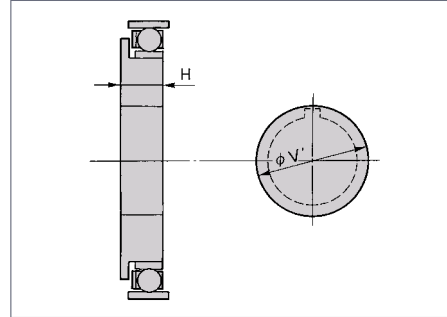

Maximum hole diameter without Oldham coupling

Table 097-2
Unit: mm

Item \ Size	14	17	20	25	32	40	45	50	58	65
Max. hole φV'	17	20	23	28	36	42	47	52	60	67
Min. plug thickness H _{min} '	7.2	7.6	11.3	11.3	13.7	15.9	17.8	19	21.4	13.5

2. Axial force of the wave generator

When a SHF/SHG gear is used to accelerate a load, the deflection of the Flexspline leads to an axial force acting on the Wave Generator. This axial force, which acts in the direction of the closed end of the Flexspline, must be supported by the bearings of the input shaft (motor shaft). When a SHF/SHG gear is used to decelerate a load, an axial force acts to push the Wave Generator out of the Flexspline cup. Maximum axial force of the Wave Generator can be calculated by the equation shown below. The axial force may vary depending on its operating condition. The value of axial force tends to be a larger number when using high torque, extreme low speed and constant operation. The force is calculated (approximately) by the equation. In all cases, the Wave Generator must be axially (in both directions), as well as torsionally, fixed to the input shaft.

(Note) Please contact us for further information on attaching the Wave Generator to the input (motor) shaft with bolts.

Axial force direction of the wave generator

Fig. 097-2

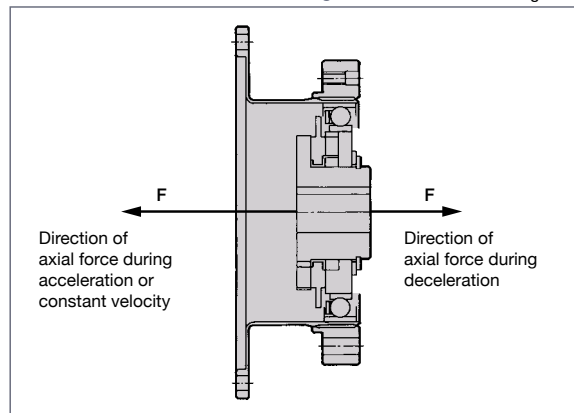

Formula for Axial Force

Table 097-3

Ratio	Calculation formula
30	$F = 2 \times \frac{T}{D} \times 0.07 \times \tan 32^\circ$
50	$F = 2 \times \frac{T}{D} \times 0.07 \times \tan 30^\circ$
80 or more	$F = 2 \times \frac{T}{D} \times 0.07 \times \tan 20^\circ$

Symbols for Formula

Table 097-4

F	Axial force	N	See Fig. 097-2.
D	(Size) × 0.00254	m	
T	Output torque	Nm	

Calculation Example

Formula 097-1

Model name : SHF series
 Size : 32
 Ratio : i=50:1
 Output torque : 382 Nm (max. allowable momentary torque)

$$F = 2 \times \frac{382}{(32 \times 0.00254)} \times 0.07 \times \tan 30^\circ$$

$$F = 380N$$

3. Shapes and dimensions of the wave generator

The shapes and dimensions of the wave generator of the SHF series are different from those of the SHG series. Exercise extreme care in design and installation. It should also be noted that the mounting bolts of the flexspline must not interfere with the wave generator.

Table 098-1 and Figure 098-1 show a comparison of the shapes and sizes of the wave generator.

Comparison of shapes and sizes of the wave generator

Fig. 098-1

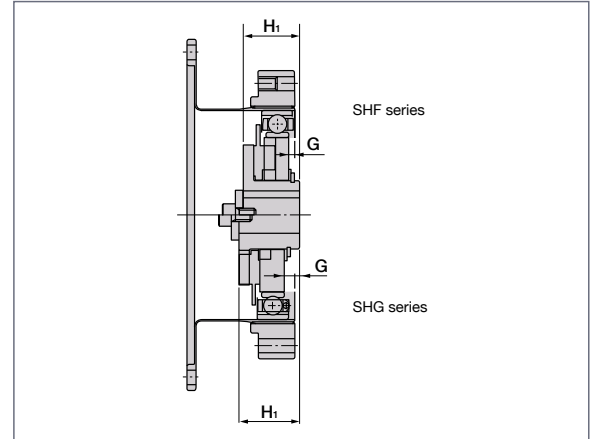

Comparison of Dimension of Wave Generator

Table 098-1
Unit: mm

Symbol	Size	14	17	20	25	32	40	45	50	58	65
G	SHG Series	1.4	1.6	1.5	3.5	4.2	5.6	6.3	7	8.2	9.5
	SHF Series	0.4	0.3	0.1	2.1	2.5	3.3	3.7	4.2	4.8	—
H ₁	SHG Series	18.5 ⁰ _{-0.1}	20.7 ⁰ _{-0.1}	21.5 ⁰ _{-0.1}	21.6 ⁰ _{-0.1}	23.6 ⁰ _{-0.1}	29.7 ⁰ _{-0.1}	30.5 ⁰ _{-0.1}	34.8 ⁰ _{-0.1}	38.3 ⁰ _{-0.1}	44.6 ⁰ _{-0.1}
	SHF Series	17.6 ⁰ _{-0.1}	19.5 ⁰ _{-0.1}	20.1 ⁰ _{-0.1}	20.2 ⁰ _{-0.1}	22 ⁰ _{-0.1}	27.5 ⁰ _{-0.1}	27.9 ⁰ _{-0.1}	32 ⁰ _{-0.1}	34.9 ⁰ _{-0.1}	—

■ Installation of the flexspline

1. Recommended size of the mounting diameter

The mounting diameter should have sufficient allowance (Size D shown in Fig. 098-2) to avoid interference with the diaphragm of the flexspline.

Observe this carefully as the diaphragm may be damaged if the diameter is too small.

Recommended size of the mounting diameter

Fig. 098-2

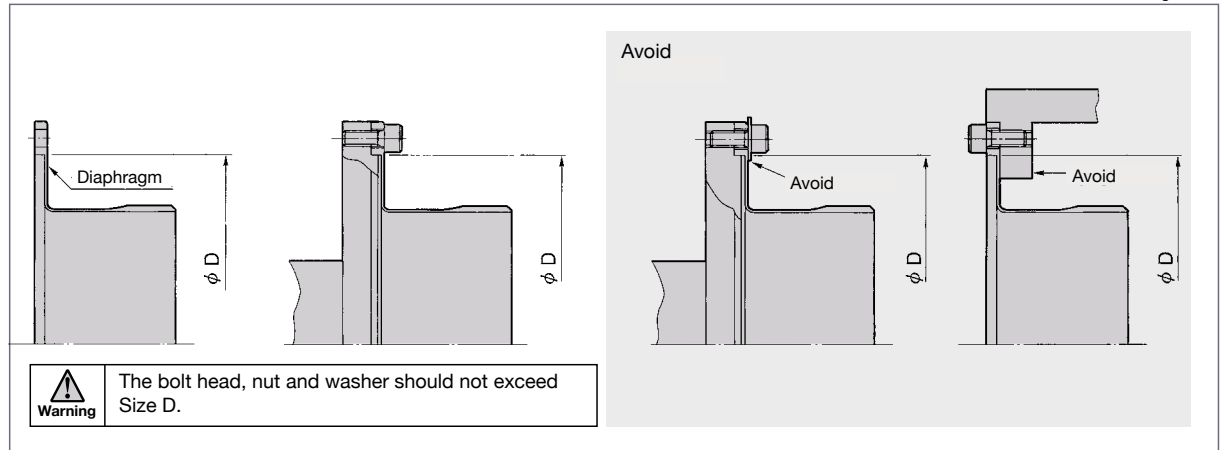

Size of the mounting diameter

Table 098-2
Unit: Ncm

Symbol	Size	14	17	20	25	32	40	45	50	58	65
φD		48	60	70	88	114	140	158	175	203	232

2. Tightening bolts of the flexspline

Bolts are tightened for installing the flexspline.

As the transmission torque on the tightening area changes significantly according to the conditions described as follows, design and part control corresponding to the load condition should be conducted.

In addition, SHG series has larger torque capacity compared with SHF series. Tighten the bolts according to each series.

- Strength of the selected bolt
- Tightening of bolts and the tightening torque
- Surface condition of bolts and tapped holes
- Friction coefficient of the contact surface

SHG series: Flexspline bolts

Table 099-1

Item \ Size		14	17	20	25	32	40	45	50	58	65
Number of bolts		8	12	12	12	12	12	18	12	16	16
Bolt size		M3	M3	M3	M4	M5	M6	M6	M8	M8	M10
Pitch Circle	mm	54	66	76	96	124	152	180	200	226	258
Clamp torque	Nm	2.4	2.4	2.4	5.4	10.8	18.4	18.4	44	44	74
Torque transmission capacity (bolt only)	Nm	108	198	228	486	1000	1740	3098	4163	6272	9546

SHF series: Flexspline bolts

Table 099-2

Item \ Size		14	17	20	25	32	40	45	50	58
Number of bolts		8	12	12	12	12	12	18	12	16
Bolt size		M3	M3	M3	M4	M5	M6	M6	M8	M8
Pitch Circle	mm	54	66	76	96	124	152	170	190	218
Clamp torque	Nm	2.0	2.0	2.0	4.5	9.0	15.3	15.3	37	37
Torque transmission capacity (bolt only)	Nm	88	157	186	402	843	1450	2430	3312	5076

(Table 099-1, 099-2/Notes)

1. The material of the thread must withstand the clamp torque.
2. Recommended bolt: JIS B 1176 socket head cap screw / Strength range: JIS B 1051 over 12.9.
3. Torque coefficient: K=0.2
4. Clamp coefficient: A=1.4
5. Tightening friction coefficient $\mu=0.15$

■ Installation of the circular spline

Perform design and part control corresponding to the load condition for installation of the circular spline in the same way as the flexspline. Transmission torques by the recommended bolts and tightening torque are shown as follows. When the transmission torque is lower than the load torque, the additional use of pins and bolts should be reviewed. Perform installation to meet the requirements of each series.

SHG series: Installation with bolts

Table 100-1

Item \ Size		14	17	20	25	32	40	45	50	58	65
Number of bolts		8	16	16	16	16	16	16	16	16	16
Bolt size		M3	M3	M3	M4	M5	M6	M8	M8	M10	M10
Pitch Circle	mm	44	54	62	75	100	120	140	150	175	195
Clamp torque	Nm	2.0	2.0	2.0	4.5	9.0	15.3	37	37	74	74
Torque transmission capacity (bolt only)	Nm	72	175	196	419	901	1530	3238	3469	6475	7215

SHF series: Installation with bolts

Table 100-2

Item \ Size		14	17	20	25	32	40	45	50	58
Number of bolts		6	12	12	12	12	12	12	12	12
Bolt size		M3	M3	M3	M4	M5	M6	M8	M8	M10
Pitch Circle	mm	44	54	62	75	100	120	140	150	175
Clamp torque	Nm	2.0	2.0	2.0	4.5	9.0	15.3	37	37	74
Torque transmission capacity (bolt only)	Nm	54	131	147	314	676	1150	2440	2620	4820

(Table 100-1, 100-2/Notes)

1. The material of the thread must withstand the clamp torque.
2. Recommended bolt: JIS B 1176 socket head cap screw / Strength range: JIS B 1051 over 12.9.
3. Torque coefficient: K=0.2
4. Clamp coefficient: A=1.4
5. Tightening friction coefficient $\mu=0.15$

■ Assembly order of the three basic elements

The wave generator is installed after the flexspline and circular spline. If the wave generator is not inserted into the flexspline last, gear teeth scuffing damage or improper eccentric gear mesh may result. Installation resulting in an eccentric tooth mesh (Dedoidal) will cause noise and vibration, and can lead to early failure of the gear. For proper function, the teeth of the flexspline and Circular Spline mesh symmetrically.

Assembly order for basic three elements

Fig. 101-1

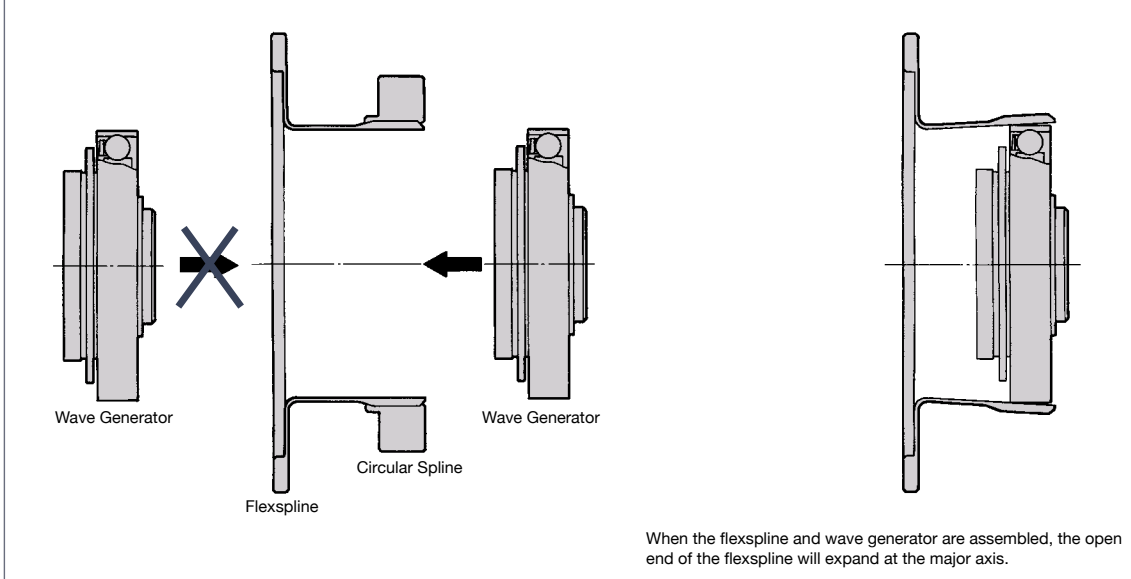

■ Precautions on assembly

It is extremely important to assemble the gear accurately and in proper sequence. For each of the three components, utilize the following precautions.

Wave generator

1. Avoid applying undue axial force to the wave generator during installation. Rotating the wave generator bearing while inserting it is recommended and will ease the process.
2. If the wave generator does not have an Oldham coupling, extra care must be given to ensure that concentricity and inclination are within the specified limits (see page 96).

Circular spline

The circular Spline must not be deformed in any way during the assembly. It is particularly important that the mounting surfaces are prepared correctly.

1. Mounting surfaces need to have adequate flatness, smoothness, and no distortion.
2. Especially in the area of the screw holes, burrs or foreign matter should not be present.
3. Adequate relief in the housing corners is needed to prevent interference with the corner of the circular spline.
4. The circular spline should be rotatable within the housing. Be sure there is not interference and that it does not catch on anything.
5. Bolts should not rotate freely when tightening and should not have any irregularity due to the bolt hole being misaligned or oblique.
6. Do not tighten the bolts with the specified torque all at once. Tighten the bolts temporarily with about half the specified torque, and then tighten them with the specified torque. Tighten them in an even, crisscross pattern.
7. Avoid pinning the circular spline if possible as it can reduce the rotational precision and smoothness of operation.

Flexspline

1. Mounting surfaces need to have adequate flatness, smoothness, and no distortion.
2. Especially in the area of the screw holes, burrs or foreign matter should not be present.
3. Adequate clearance with the housing is needed to ensure no interference especially with the major axis of flexspline
4. Bolts should rotate freely when installing through the mounting holes of the flexspline and should not have any irregularity due to the shaft bolt holes being misaligned or oblique.
5. Do not tighten the bolts with the specified torque all at once. Tighten the bolts temporarily with about half the specified torque, and then tighten them to the specified torque. Tighten them in an even, crisscross pattern.
6. The flexspline and circular spline are concentric after assembly. After installing the wave generator bearing, if it rotates in unbalanced way, check the mounting for dedoidal or non-concentric installation.
7. Care should be taken not to damage the flexspline diaphragm or gear teeth during assembly.
Avoid hitting the tips of the flexpline teeth and circular spline teeth. Avoid installing the circular spline from the open side of the flexspline after the wave generator has been installed.

Rust prevention

Although Harmonic Drive® gears come with some corrosion protection, the gear can rust if exposed to the environment. The gear external surfaces typically have only a temporary corrosion inhibitor and some oil applied. If an anti-rust product is needed, please contact us to review the options.

Engineering Data

Engineering Data

Tooth profile	• S tooth profile	009
Rotational direction and reduction ratio	• Cup style	010
	• Silk hat style	010
	• Pancake style	011
Rating table definitions		012
Life		012
Torque limits		013
Product sizing and selection		014
Lubrication	• Grease lubricant	016
	• Precautions on using Harmonic Grease® 4B No.2	018
	• Oil lubricant	018
	• Lubricant for special environments	019
Torsional stiffness		020
Positional accuracy		021
Vibration		021
Starting torque		022
Backdriving torque		022
No-load running torque		023
Efficiency		023
Design guidelines	• Design guideline	024
	• Bearing support of the input and output shafts	025
	• Wave Generator	026
Assembly guidelines	• Sealing	028
	• Assembly Precautions	028
	• "dedoidal" state	029
Checking output bearing	• Checking procedure	030
	• How to calculate the maximum moment load	030
	• How to calculate the average load	031
	• How to calculate the radial load coefficient (X) and axial load coefficient (Y)	031
	• How to calculate life	032
	• How to calculate the life under oscillating movement	033
	• How to calculate the static safety coefficient	034

Tooth Profile

■ S tooth profile

Harmonic Drive developed a unique gear tooth profile that optimizes the tooth engagement. It has a special curved surface unique to the S tooth profile that allows continuous contact with the tooth profile. It also alleviates the concentration of stress by widening the width of the tooth groove against the tooth thickness and enlarging the radius on the bottom. This tooth profile (the "S tooth") enables up to 30% of the total number of teeth to be engaged simultaneously.

Additionally the large tooth root radius increases the tooth strength compared with an involute tooth. This technological innovation results in high torque, high torsional stiffness, long life and smooth rotation.

*Patented

Engaged route of teeth

Fig. 009-1

Conventional tooth profile

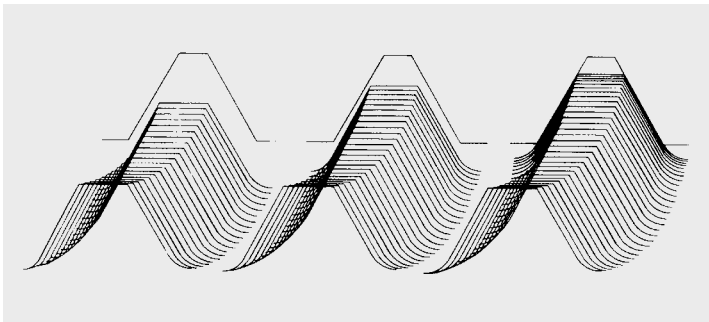

S tooth profile

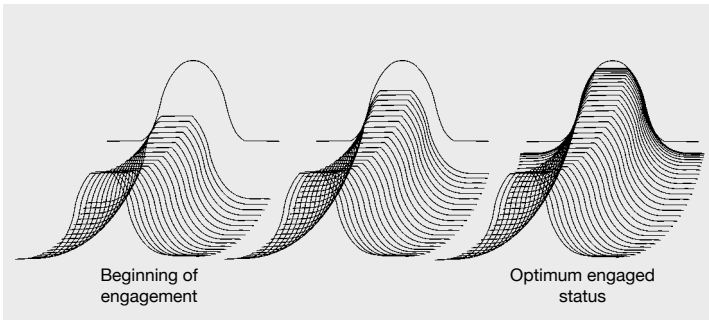

Engaged area of teeth

Fig. 009-2

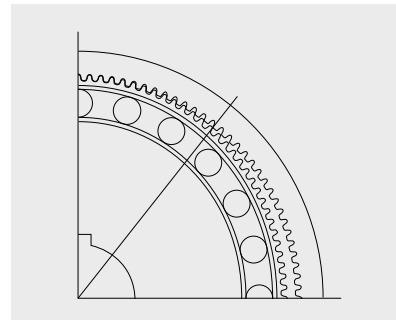
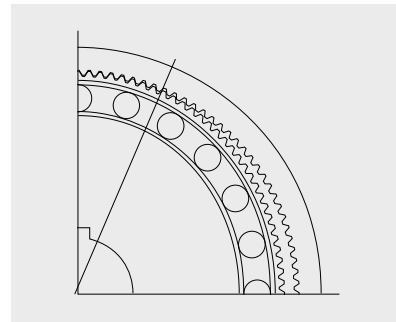

Rotational direction and reduction ratio

Cup Style

Series: CSG, CSF, CSD, CSF-mini

Rotational direction

Fig. 010-1

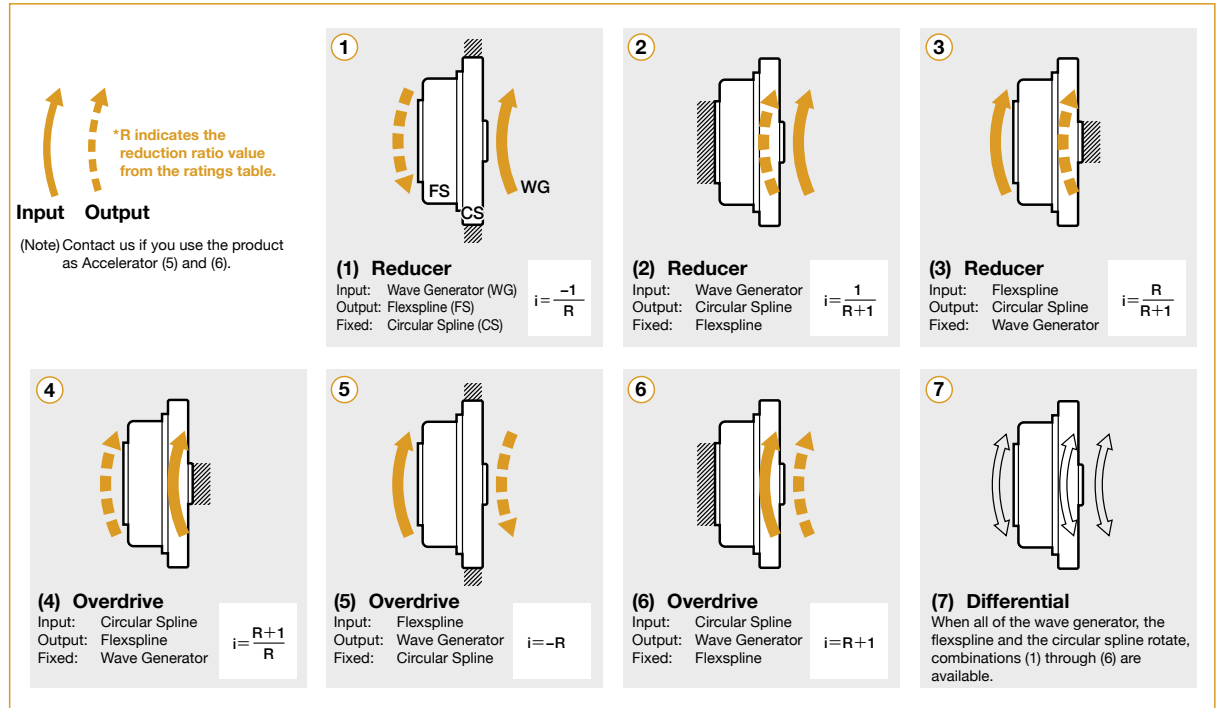

Silk hat

Series: SHG, SHF, SHD

Rotational direction

Fig. 010-2

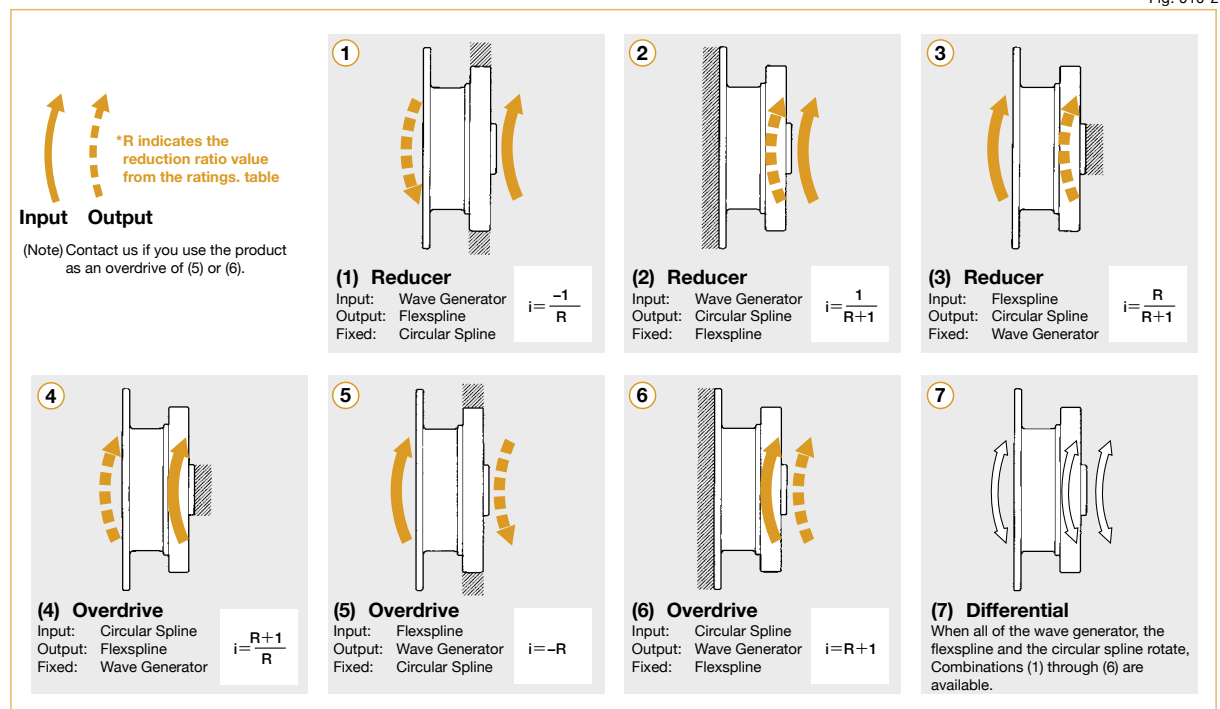

Pancake

Series: FB and FR

Rotational direction

Fig. 11-1

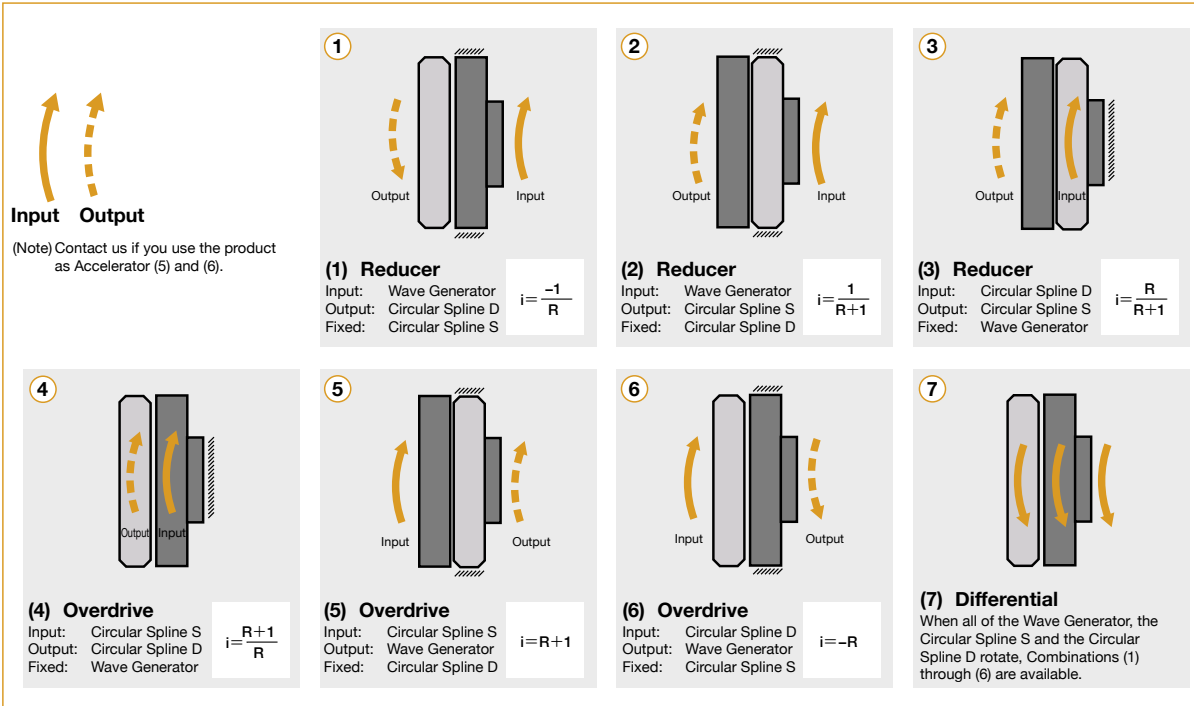

Reduction ratio

The reduction ratio is determined by the number of teeth of the Flexspline and the Circular Spline

Number of teeth of the Flexspline: Z_f
Number of teeth of the Circular Spline: Z_c

Example

Number of teeth of the Flexspline: 200
Number of teeth of the Circular Spline: 202

► Input: Wave Generator
Output: Flexspline
Fixed: Circular Spline } Reduction ratio $i_1 = \frac{1}{R_1} = \frac{Z_f - Z_c}{Z_f}$

► Input: Wave Generator
Output: Flexspline
Fixed: Circular Spline } Reduction ratio $i_1 = \frac{1}{R_1} = \frac{200 - 202}{200} = \frac{-1}{100}$

► Input: Wave Generator
Output: Circular Spline
Fixed: Flexspline } Reduction ratio $i_2 = \frac{1}{R_2} = \frac{Z_c - Z_f}{Z_c}$

► Input: Wave Generator
Output: Circular Spline
Fixed: Flexspline } Reduction ratio $i_2 = \frac{1}{R_2} = \frac{202 - 200}{202} = \frac{1}{101}$

■ R_1 indicates the reduction ratio value from the ratings table.

Rating Table Definitions

See the corresponding pages of each series for values.

Rated torque

Rated torque indicates allowable continuous load torque at rated input speed.

Limit for Repeated Peak Torque (see Graph 12-1)

During acceleration and deceleration the Harmonic Drive® gear experiences a peak torque as a result of the moment of inertia of the output load. The table indicates the limit for repeated peak torque.

Limit for Average Torque

In cases where load torque and input speed vary, it is necessary to calculate an average value of load torque. The table indicates the limit for average torque. The average torque calculated must not exceed this limit. (calculation formula: Page 14)

Limit for Momentary Peak Torque (see Graph 12-1)

The gear may be subjected to momentary peak torques in the event of a collision or emergency stop. The magnitude and frequency of occurrence of such peak torques must be kept to a minimum and they should, under no circumstance, occur during normal operating cycle. The allowable number of occurrences of the momentary peak torque may be calculated by using formula 13-1.

Maximum Average Input Speed Maximum Input Speed

Do not exceed the allowable rating. (calculation formula of the average input speed: Page 14).

Moment of Inertia

The rating indicates the moment of inertia reflected to the gear input.

Example of application motion profile

Graph 012-1

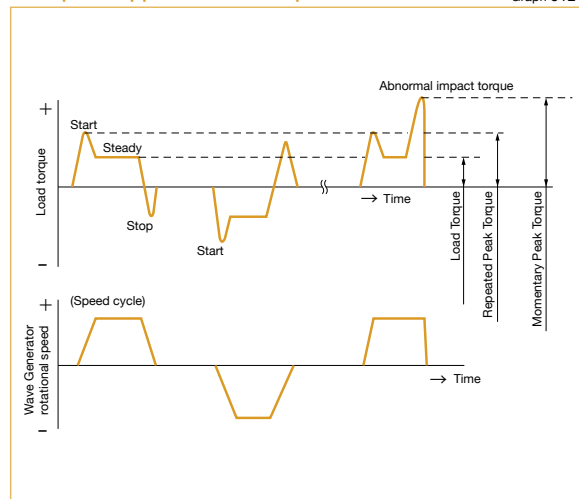

Life

Life of the wave generator

The life of a gear is determined by the life of the wave generator bearing. The life may be calculated by using the input speed and the output load torque.

Table 012-1

Series name	Life	
	CSF, CSD, SHF, SHD, CSF-mini	CSG, SHG
L ₁₀	7,000 hours	10,000 hours
L ₅₀ (average life)	35,000 hours	50,000 hours

* Life is based on the input speed and output load torque from the rating table.

Calculation formula for Rated Lifetime

Formula 012-1

$$L_h = L_n \cdot \left(\frac{T_r}{T_{av}} \right)^3 \cdot \left(\frac{N_r}{N_{av}} \right)$$

Table 012-2

L _n	Life of L ₁₀ or L ₅₀
T _r	Rated torque
N _r	Rated input speed
T _{av}	Average load torque on the output side (calculation formula: Page 14)
N _{av}	Average input speed (calculation formula: Page 14)

Relative torque rating

Graph 012-2

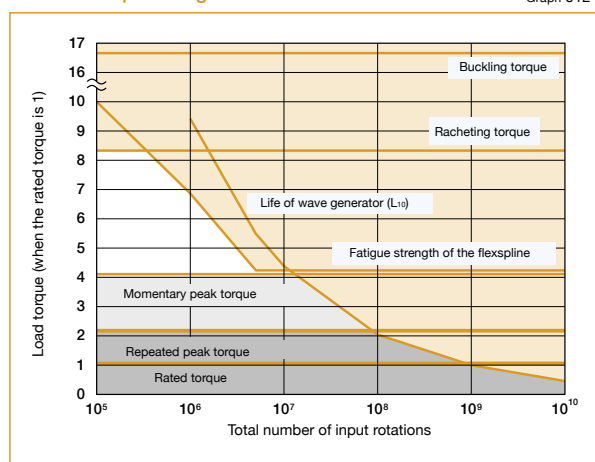

* Lubricant life not taken into consideration in the graph described above.

* Use the graph above as reference values.

Torque Limits

Strength of flexspline

The Flexspline is subjected to repeated deflections, and its strength determines the torque capacity of the Harmonic Drive® gear. The values given for Rated Torque at Rated Speed and for the allowable Repeated Peak Torque are based on an infinite fatigue life for the Flexspline.

The torque that occurs during a collision must be below the momentary peak torque (impact torque). The maximum number of occurrences is given by the equation below.

Allowable limit of the bending cycles of the flexspline during rotation of the wave generator while the impact torque is applied: 1.0×10^4 (cycles)

The torque that occurs during a collision must be below the momentary peak torque (impact torque). The maximum number of occurrences is given by the equation below.

Calculation formula

Formula 013-1

$$N = \frac{1.0 \times 10^4}{2 \times \frac{n}{60} \times t}$$

Allowable occurrences	N occurrences
Time that impact torque is applied	t sec
Rotational speed of the wave generator	n rpm
The flexspline bends two times per one revolution of the wave generator.	

Caution If the number of occurrences is exceeded, the Flexspline may experience a fatigue failure.

Buckling torque

When a highly excessive torque (16 to 17 times rated torque) is applied to the output with the input stationary, the flexspline may experience plastic deformation. This is defined as buckling torque.

* See the corresponding pages of each series for buckling torque values.

Warning When the flexspline buckles, early failure of the HarmonicDrive® gear will occur.

Ratcheting torque

When excessive torque (8 to 9 times rated torque) is applied while the gear is in motion, the teeth between the Circular Spline and Flexspline may not engage properly.

This phenomenon is called ratcheting and the torque at which this occurs is called ratcheting torque. Ratcheting may cause the Flexspline to become non-concentric with the Circular Spline. Operating in this condition may result in shortened life and a Flexspline fatigue failure.

* See the corresponding pages of each series for ratcheting torque values.
 * Ratcheting torque is affected by the stiffness of the housing to be used when installing the circular spline. Contact us for details of the ratcheting torque.

Caution When ratcheting occurs, the teeth may not be correctly engaged and become out of alignment as shown in Figure 013-1. Operating the drive in this condition will cause vibration and damage the flexspline.

Caution Once ratcheting occurs, the teeth wear excessively and the ratcheting torque may be lowered.

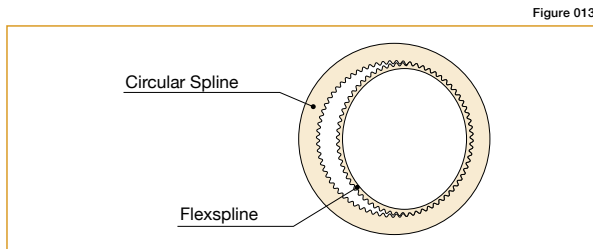

Figure 013-1

"Dedoidal" condition.

Product Sizing & Selection

In general, a servo system rarely operates at a continuous load and speed. The input rotational speed, load torque change and comparatively large torque are applied at start and stop. Unexpected impact torque may be applied. These fluctuating load torques should be converted to the average load torque when selecting a model number. As an accurate cross roller bearing is built in the direct external load support (output flange), the maximum moment load, life of the cross roller bearing and the static safety coefficient should also be checked.

Checking the application motion profile

Review the application motion profile. Check the specifications shown in the figure below.

Graph 14-1

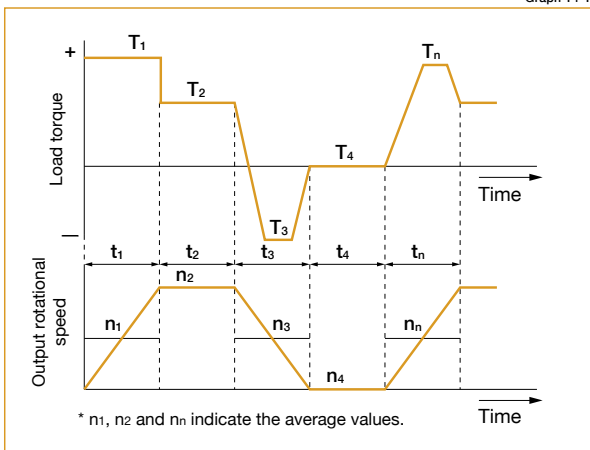

Obtain the value of each application motion profile.	
Load torque	T_n (Nm)
Time	t_n (sec)
Output rotational speed	n_n (rpm)
Normal operation pattern	
Starting (acceleration)	T_1, t_1, n_1
Steady operation (constant velocity)	T_2, t_2, n_2
Stopping (deceleration)	T_3, t_3, n_3
Dwell	T_4, t_4, n_4
Maximum rotational speed	
Max. output speed	$n_{o\ max}$
Max. input rotational speed (Restricted by motors)	$n_{i\ max}$
Emergency stop torque	
When impact torque is applied	T_s, t_s, n_s
Required life	
	$L_{10} = L$ (hours)

Flowchart for selecting a size

Please use the flowchart shown below for selecting a size. Operating conditions must not exceed the performance ratings.

Calculate the average load torque applied on the output side from the application motion profile: T_{av} (Nm).

$$T_{av} = \sqrt[3]{\frac{n_1 \cdot t_1 \cdot |T_1|^3 + n_2 \cdot t_2 \cdot |T_2|^3 + \dots + n_n \cdot t_n \cdot |T_n|^3}{n_1 \cdot t_1 + n_2 \cdot t_2 + \dots + n_n \cdot t_n}}$$

Make a preliminary model selection with the following conditions.
 $T_{av} \leq$ Limit for average torque (torque)
 (See the rating table of each series).

Calculate the average output speed: $n_{o\ av}$ (rpm)

$$n_{o\ av} = \frac{n_1 \cdot t_1 + n_2 \cdot t_2 + \dots + n_n \cdot t_n}{t_1 + t_2 + \dots + t_n}$$

Obtain the reduction ratio (R). A limit is placed on "ni max" by motors.

$$\frac{n_{i\ max}}{n_{o\ max}} \geq R$$

Calculate the average input rotational speed from the average output rotational speed ($n_{o\ av}$) and the reduction ratio (R): $n_{i\ av}$ (rpm)

$$n_{i\ av} = n_{o\ av} \cdot R$$

Calculate the maximum input rotational speed from the max. output rotational speed ($n_{o\ max}$) and the reduction ratio (R): $n_{i\ max}$ (rpm)

$$n_{i\ max} = n_{o\ max} \cdot R$$

Check whether the preliminary model number satisfies the following condition from the rating table.

$n_{i\ av} \leq$ Limit for average speed (rpm)

$n_{i\ max} \leq$ Limit for maximum speed (rpm)

NG

OK

Check whether T_1 and T_3 are less than the repeated peak torque specification.

NG

OK

Check whether T_s is less than the the momentary peak torque specification.

NG

OK

Calculate (N_s) the allowable number of rotations during impact torque.

$$N_s = \frac{10^4}{2 \cdot \frac{n_s \cdot R}{60} \cdot t} \dots \dots N_s \leq 1.0 \times 10^4$$

NG

OK

Calculate the lifetime.

$$L_{10} = 7000 \cdot \left(\frac{T_r}{T_{av}} \right)^3 \cdot \left(\frac{n_r}{n_{i\ av}} \right) \text{ (hours)}$$

Check whether the calculated life is equal to or more than the life of the wave generator (see Page 13).

NG

OK

The model number is confirmed.

Review the operation conditions and model number

Example of model number selection

Value of each application motion profile

Load torque	T_n (Nm)
Time	t_n (sec)
Output speed	n_n (rpm)

Normal operation pattern

Starting (acceleration)	$T1 = 400$ Nm, $t1 = 0.3$ sec, $n1 = 7$ rpm
Steady operation (constant velocity)	$T2 = 320$ Nm, $t2 = 3$ sec, $n2 = 14$ rpm
Stopping (deceleration)	$T3 = 200$ Nm, $t3 = 0.4$ sec, $n3 = 7$ rpm
Dwell	$T4 = 0$ Nm, $t4 = 0.2$ sec, $n4 = 0$ rpm

Maximum rotational speed

Max. output speed	$n_o \max = 14$ rpm
Max. input speed (Restricted by motors)	$n_i \max = 1800$ rpm

Emergency stop torque

When impact torque is applied	$T_s = 500$ Nm, $t_s = 0.15$ sec, $n_s = 14$ rpm
-------------------------------	--

Required life

$L_{10} = 7000$ (hours)

Calculate the average load torque to the output side based on the application motion profile: T_{av} (Nm).

$$T_{av} = 3 \sqrt{\frac{7 \text{ rpm} \cdot 0.3 \text{ sec} \cdot |400 \text{ Nm}|^3 + 14 \text{ rpm} \cdot 3 \text{ sec} \cdot |320 \text{ Nm}|^3 + 7 \text{ rpm} \cdot 0.4 \text{ sec} \cdot |200 \text{ Nm}|^3}{7 \text{ rpm} \cdot 0.3 \text{ sec} + 14 \text{ rpm} \cdot 3 \text{ sec} + 7 \text{ rpm} \cdot 0.4 \text{ sec}}}$$

Make a preliminary model selection with the following conditions. $T_{av} = 319$ Nm \leq 451 Nm (Limit for average torque for model number CSF-40-120-2A-GR: See the rating table on Page 39.) Thus, **CSF-40-120-2A-GR** is tentatively selected.

Calculate the average output rotational speed: n_{av} (rpm)

$$n_{av} = \frac{7 \text{ rpm} \cdot 0.3 \text{ sec} + 14 \text{ rpm} \cdot 3 \text{ sec} + 7 \text{ rpm} \cdot 0.4 \text{ sec}}{0.3 \text{ sec} + 3 \text{ sec} + 0.4 \text{ sec} + 0.2 \text{ sec}} = 12 \text{ rpm}$$

Obtain the reduction ratio (R).

$$\frac{1800 \text{ rpm}}{14 \text{ rpm}} = 128.6 \geq 120$$

Calculate the average input rotational speed from the average output rotational speed (n_{av}) and the reduction ratio (R): n_{iav} (rpm)

$$n_{iav} = 12 \text{ rpm} \cdot 120 = 1440 \text{ rpm}$$

Calculate the maximum input rotational speed from the maximum output rotational speed (n_{max}) and the reduction ratio (R): n_{imax} (rpm)

$$n_{imax} = 14 \text{ rpm} \cdot 120 = 1680 \text{ rpm}$$

Check whether the preliminary selected model number satisfies the following condition from the rating table.

$$n_{iav} = 1440 \text{ rpm} \leq 3600 \text{ rpm (Max average input speed of size 40)}$$

$$n_{imax} = 1680 \text{ rpm} \leq 5600 \text{ rpm (Max input speed of size 40)}$$

NG

OK

Check whether $T1$ and $T3$ are equal to or less than the repeated peak torque specification.

$$T1 = 400 \text{ Nm} \leq 617 \text{ Nm (Limit of repeated peak torque of size 40)}$$

$$T3 = 200 \text{ Nm} \leq 617 \text{ Nm (Limit of repeated peak torque of size 40)}$$

NG

OK

Check whether T_s is equal to or less than the momentary peak torque specification.

$$T_s = 500 \text{ Nm} \leq 1180 \text{ Nm (Limit for momentary torque of size 40)}$$

NG

OK

Calculate the allowable number (N_s) rotation during impact torque and confirm $\leq 1.0 \times 10^4$

$$N_s = \frac{10^4}{2 \cdot \frac{14 \text{ rpm} \cdot 120}{60} \cdot 0.15 \text{ sec}} = 1190 \leq 1.0 \times 10^4$$

NG

OK

Calculate the lifetime.

$$L_{10} = 7000 \cdot \left(\frac{294 \text{ Nm}}{319 \text{ Nm}} \right)^3 \cdot \left(\frac{2000 \text{ rpm}}{1440 \text{ rpm}} \right) \text{ (hours)}$$

Check whether the calculated life is equal to or more than the life of the wave generator (see Page 12).

$$L_{10} = 7610 \text{ hours} \geq 7000 \text{ (life of the wave generator: } L_{10})$$

NG

OK

The selection of model number **CSF-40-120-2A-GR** is confirmed from the above calculations.

Review the operation conditions, size and reduction ratio

Lubrication

Component Sets: CSD-2A, CSF-2A, CSG-2A, FB-2, FB-0, FR-2, SHF-2A, SHG-2A and SHD and SHG/SHF -2SO and -2SH gear units: Grease lubricant and oil lubricant are available for lubricating the component sets and SHD gear unit. It is extremely important to properly grease your component sets and SHD gear unit. Proper lubrication is essential for high performance and reliability. Harmonic Drive® component sets are shipped with a rust- preventative oil. The characteristics of the lubricating grease and oil types approved by Harmonic Drive are not changed by mixing with the preservation oil. It is therefore not necessary to remove the preservation oil completely from the gear components. However, the mating surfaces must be degreased before the assembly.

Gear Units: CSG/CSF 2UH and 2UH-LW; CSD-2UF and -2UH; SHG/SHF-2UH and 2UH- LW; SHG/SHF-2UJ; CSF Supermini, CSF Mini, and CSF-2UP.

Grease lubricant is standard for lubricating the gear units. You do not need to apply grease during assembly as the product is lubricated and shipped.

See Page 19 for using lubricant beyond the temperature range in table 16-2.

* Contact us if you want consistency zero (NLGI No.0) for maintenance reasons.

Grease lubricant

Types of lubricant

Harmonic Grease® SK-1A

This grease was developed for Harmonic Drive® gears and features good durability and efficiency.

Harmonic Grease® SK-2

This grease was developed for small sized Harmonic Drive® gears and features smooth rotation of the Wave Generator since high pressure additive is liquefied.

Harmonic Grease® 4B No.2

This has been developed exclusively for the CSF and CSG and features long life and can be used over a wide range of temperature.

(Note)

- Grease lubrication must have proper sealing, this is essential for 4B No.2. Rotating part: Oil seal with spring is needed. Mating part: O ring or seal adhesive is needed.
- The grease has the highest deterioration rate in the region where the grease is subjected to the greatest shear (near wave generator). Its viscosity is between JIS No.0 and No.00 depending on the operation.

Table 016-3

NLGI consistency No.	Mixing consistency range
0	355 to 385
00	400 to 430

Grease specification

Table 016-4

Grease	SK-1A	SK-2	4B No.2
Base oil	Refined oil	Refined oil	Composite hydrocarbon oil
Base Viscosity cSt (25°C)	265 to 295	265 to 295	290 to 320
Thickening agent	Lithium soap base	Lithium soap base	Urea
NLGI consistency No.	No. 2	No. 2	No. 1.5
Additive	Extreme-pressure additive, others	Extreme-pressure additive, others	Extreme-pressure additive, others
Drop Point	197°C	198°C	247°C
Appearance	Yellow	Green	Light yellow
Storage life	5 years in sealed condition	5 years in sealed condition	5 years in sealed condition

Name of lubricant

Table 016-1

Grease	Harmonic Grease® SK-1A
	Harmonic Grease® SK-2
	Harmonic Grease® 4B No.2
Oil	Industrial gear oil class-2 (extreme pressure) ISO VG68

Temperature

Table 016-2

Grease	SK-1A 0°C to + 40°C
	SK-2 0°C to + 40°C
	4B No.2 -10°C to + 70°C
Oil	ISO VG68 0°C to + 40°C

* The hottest section should not be more than 40° above the ambient temperature.

Note: The three basic components of the gear - the Flexspline, Wave Generator and Circular Spline - are matched and serialized in the factory. Depending on the product they are either greased or prepared with preservation oil. Then the individual components are assembled. If you receive several units, please be careful not to mix the matched components. This can be avoided by verifying that the serial numbers of the assembled gear components are identical.

Compatible grease by size

Compatible grease varies depending on the size and reduction ratio. See the following compatibility table. We recommend SK-1A and SK-2 for general use.

Ratios 30:1

Table 016-5

Size	8	11	14	17	20	25	32
SK-1A	—	—	—	—	○	○	○
SK-2	○	○	○	○	—	—	—
4B No.2	△	△	△	△	□	□	□

Ratios 50:1* and above

Table 016-6

Size	8	11	14	17	20	25	32
SK-1A	—	—	—	—	○	○	○
SK-2	○	○	○	○	△	△	△
4B No.2	—	—	□	□	□	□	□

Size	40	45	50	58	65	80	90	100
SK-1A	○	○	○	○	○	○	○	○
SK-2	△	—	—	—	—	—	—	—
4B No.2	□	□	□	□	□	□	□	□

○: Standard grease

△: Semi-standard grease

□: Recommended grease for long life and high load

* Oil lubrication is required for component-sets size 50 or larger with a reduction ratio of 50:1.

Grease characteristics

Table 016-7

Grease	SK-1A	SK-2	4B No.2
Durability	○	○	◎
Fretting resistance	○	○	◎
Low-temperature performance	△	△	◎
Grease leakage	◎	◎	△

Excellent :◎

Good :○

Use Caution :△

When to replace grease

The wear characteristics of the gear are strongly influenced by the condition of the grease lubrication. The condition of the grease is affected by the ambient temperature. The graph 017-1 shows the maximum number of input rotations for various temperatures. This graph applies to applications where the average load torque does not exceed the rated torque.

Note: Recommended Grease: SK-1A or SK-2

When to replace grease: L_{GTn} (when the average load torque is equal to or less than the rated torque)

Graph 017-1

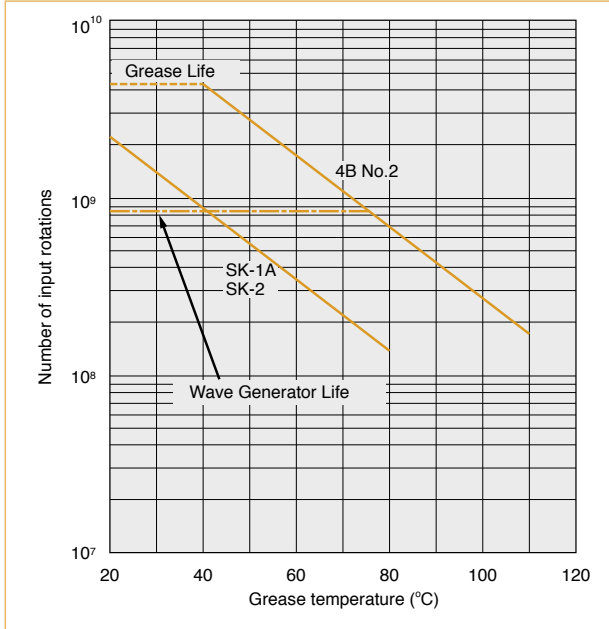

Calculation formula when the average load torque exceeds the rated torque

Formula 017-1

$$L_{GT} = L_{GTn} \times \left(\frac{T_r}{T_{av}} \right)^3$$

Formula Symbols

Table 017-1

L_{GT}	Grease change (if average load torque exceeds rated torque)	input revolutions	_____
L_{GTn}	Grease change (if average load torque is equal to or less than rated torque)	input revolutions (From Graph)	See the Graph 017-1.
T_r	Rated torque	Nm	See the "Ratings Table" of each series.
T_{av}	Average load torque	Nm	Calculation formula: See Page 014.

Other precautions

1. Avoid mixing different kinds of grease. The gear should be in an individual case when installed.
2. Please contact us when you use HarmonicDrive® gears at constant load or in one direction continuously, as it may cause lubrication problems.
3. Grease leakage. A sealed structure is needed to maintain the high durability of the gear and prevent grease leakage.

See the corresponding pages of the design guide of each series for "Recommended minimum housing clearance," Application guide" and "Application quantity."

Precautions on using Harmonic Grease® 4B No.2

Harmonic Grease® 4B No.2 lubrication is ideally suited for Harmonic Drive® gears.

- (1) Apply the grease to each contacting joint at the beginning of operation.
- (2) Remove any contaminants created by abrasion during running-in period.

■ See the corresponding pages of the design guide of each series for “recommended minimum housing clearance,” Application guide” and “Application quantity.”

■ **Precautions**

(1) Stir Grease

When storing Harmonic Grease 4B No.2 lubrication in the container, it is common for the oil to weep from the thickener. Before greasing, stir the grease in the container to mix and soften.

(2) Aging (running-in)

The aging before the main operation softens the applied grease. More effective greasing performance can be realized when the grease is distributed around each contact surface.

Therefore, the following aging methods are recommended.

- Keep the internal temperature at 80°C or cooler. Do not start the aging at high temperature rapidly.
- Input rotational speed should be 1000rpm to 3000rpm. However, the lower rotational speed of 1000rpm is more effective. Set the speed as low as possible within the indicated range.
- The time required for aging is 20 minutes or longer.
- Operation range for aging: Keep the output rotational angle as large as possible.

Contact us if you have any questions for handling Harmonic Grease 4B No.2 lubrication.

Note: Strict sealing is required to prevent grease leakage.

Oil lubricant

■ **Types of oil**

The specified standard lubricant is “Industrial gear oil class-2 (extreme pressure) ISO VG68.” We recommend the following brands as a commercial lubricant.

Table 018-1

Standard	Mobil Oil	Exxon	Shell	COSMO Oil	Japan Energy	NIPPON Oil	Idemitsu Kosan	General Oil	Klüber
Industrial gear oil class-2 (extreme pressure) ISO VG68	Mobilgear 600XP68	Spartan EP68	Omala Oil 68	Cosmo gear SE68	ES gear G68	Bonock M68, Bonock AX68	Daphne super gear LW68	General Oil SP gear roll 68	Syntheso D-68EP

■ **When to replace oil**

First time 100 hours after starting operation

Second time or after Every 1000 operation hours or every 6 months

Note that you should replace the oil earlier than specified if the operating condition is demanding.

■ See the corresponding pages of the design guide of each series for specific details.

■ **Other precautions**

1. Avoid mixing different kinds of oil. The gear should be in an individual case when installed.
2. When you use size 50 or above at max allowable input speed, please contact us as it may cause lubrication problems.

* Oil lubrication is required for component-sets size 50 or larger with a reduction ratio of 50:1.

Lubricant for special environments

When the ambient temperature is special (other than the “temperature range of the operating environment” on Page 016-2), you should select a lubricant appropriate for the operating temperature range.

Harmonic Grease 4B No.2

Table 019-1

Type of lubricant	Operating temperature range	Available temperature range
Grease	-10°C to + 110°C	-50°C to + 130°C

Harmonic Grease 4B No.2

The operating temperature range of Harmonic Grease 4B No.2 lubrication is the temperature at the lubricating section with the performance and characteristics of the gear taken into consideration. (It is not ambient temperature.)

High temperature lubricant

Table 019-2

Type of lubricant	Lubricant and manufacturer	Available temperature range
Grease	Mobil grease 28: Mobil Oil	-5°C to + 160°C
Oil	Mobil SHC-626: Mobil Oil	-5°C to + 140°C

As the available temperature range indicates the temperature of the independent lubricant, restriction is added on operating conditions (such as load torque, rotational speed and operating cycle) of the gear. When the ambient temperature is very high or low, materials of the parts of the gear need to be reviewed for suitability. Contact us if operating in high temperature.

Harmonic Grease 4B No.2 can be used in the available temperature range shown in table 019-1. However, input running torque will increase at low temperatures, and grease life will be decreased at high temperatures due to oxidation and lubricant degradation.

Low temperature lubricant

Table 019-3

Type of lubricant	Lubricant and manufacturer	Available temperature range
Grease	Multemp SH-KII: Kyodo Oil	-30°C to + 50°C
	Isoflex LDS-18 special A: KLÜBER	-25°C to + 80°C
Oil	SH-200-100CS: Toray Silicon	-40°C to + 140°C
	Syntheso D-32EP: KLÜBER	-25°C to + 90°C

Torsional Stiffness

Stiffness and backlash of the drive system greatly affects the performance of the servo system. Please perform a detailed review of these items before designing your equipment and selecting a model number.

Stiffness

Fixing the input side (wave generator) and applying torque to the output side (flexspline) generates a torsional angle almost proportional to the torque on the output side. Figure 020-1 shows the torsional angle at the output side when the torque applied on the output side starts from zero, increases up to $+T_0$ and decreases down to $-T_0$. This is called the "Torque - torsion angle diagram," which normally draws a loop of $0 - A - B - A' - B' - A$. The slope described in the "Torque - torsion angle diagram" is represented as the spring constant for the stiffness of the HarmonicDrive® gear (unit: Nm/rad).

As shown in Figure 020-2 "Spring Constant Diagram" is divided into 3 regions, and the spring constants in the area are represented by K_1 , K_2 and K_3 .

K_1 ... The spring constant when the torque changes from [zero] to $[T_1]$

K_2 ... The spring constant when the torque changes from $[T_1]$ to $[T_2]$

K_3 ... The spring constant when the torque changes from $[T_2]$ to $[T_3]$

- See the corresponding pages of each series for values of the spring constants (K_1 , K_2 , K_3) and the torque-torsional angles (T_1 , T_2 , $- \theta_1$, θ_2).

Example for calculating the torsion angle

The torsion angle (θ) is calculated here using CSF-25-100-2A-GR as an example.

When the applied torque is T_1 or less, the torsion angle θ_{L1} is calculated as follows:

$$\begin{aligned}\theta_{L1} &= T_{L1}/K_1 \\ &= 2.9/3.1 \times 10^4 \\ &= 9.4 \times 10^{-5} \text{ rad (0.33 arc min)}\end{aligned}$$

When the applied torque is between T_1 and T_2 , the torsion angle θ_{L2} is calculated as follows:

$$\begin{aligned}\theta_{L2} &= \theta_1 + (T_{L2} - T_1)/K_2 \\ &= 4.4 \times 10^{-4} + (39 - 14)/5.0 \times 10^4 \\ &= 9.4 \times 10^{-4} \text{ rad (3.2 arc min)}\end{aligned}$$

When a bidirectional load is applied, the total torsion angle will be $2 \times \theta_{Lx}$ plus hysteresis loss.

* The torsion angle calculation is for the gear component set only and does not include any torsional windup of the output shaft.

Note: See p.120 for torsional stiffness for pancake gearing .

Hysteresis loss (Silk hat and cup style only)

As shown in Figure 020-1, when the applied torque is increased to the rated torque and is brought back to [zero], the torsional angle does not return exactly to the zero point. This small difference ($B - B'$) is called hysteresis loss.

- See the corresponding page of each series for the hysteresis loss value.

Torque - torsion angle diagram

Figure 020-1

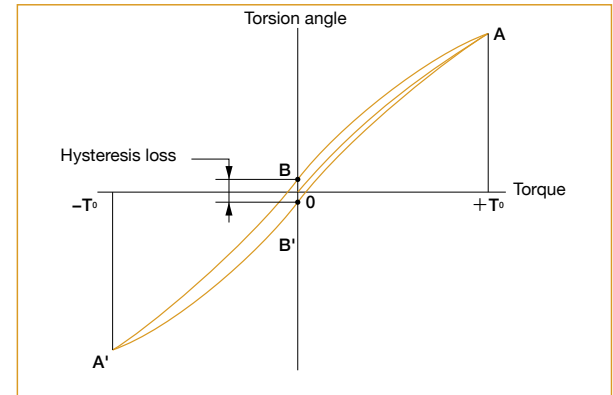

Spring constant diagram

Figure 020-2

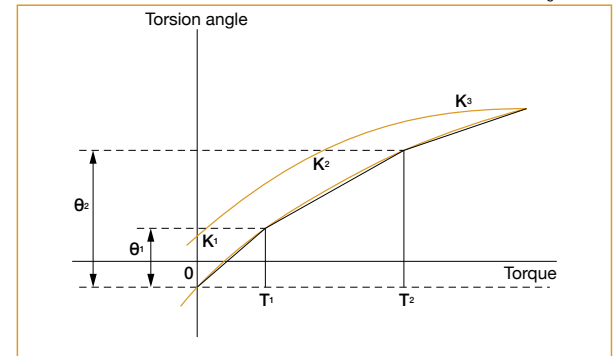

Backlash (Silk hat and cup style only)

Hysteresis loss is primarily caused by internal friction. It is a very small value and will vary roughly in proportion to the applied load. Because HarmonicDrive® gears have zero backlash, the only true backlash is due to the clearance in the Oldham coupling, a self-aligning mechanism used on the wave generator. Since the Oldham coupling is used on the input, the backlash measured at the output is extremely small (arc-seconds) since it is divided by the gear reduction ratio.

Positional Accuracy

Positional Accuracy values represent the difference between the theoretical angle and the actual angle of output for any given input. The values shown in the table are maximum values.

■ See the corresponding pages of each series for transmission accuracy values.

Example of measurement

Graph 021-1

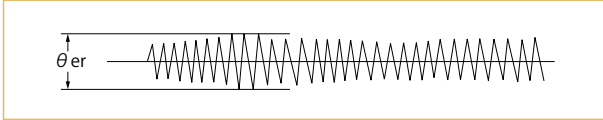

Table 021-1

θ_{er}	Transmission accuracy
θ_1	Input angle
θ_2	Actual output angle
R	Reduction ratio

Formula 021-1

$$\theta_{er} = \theta_2 - \frac{\theta_1}{R}$$

Vibration

The primary frequency of the transmission error of the HarmonicDrive® gear may cause a vibration of the load inertia. This can occur when the driving frequency of the servo system including the HarmonicDrive® gear is at, or close to the resonant frequency of the system. Refer to the design guide of each series.

The primary component of the transmission error occurs twice per input revolution of the input. Therefore, the frequency generated by the transmission error is 2x the input frequency (rev / sec).

If the resonant frequency of the entire system, including the HarmonicDrive® gear, is $F=15$ Hz, then the input speed (N) which would generate that frequency could be calculated with the formula below.

Formula 021-2

$$N = \frac{15}{2} \cdot 60 = 450 \text{ rpm}$$

The resonant frequency is generated at an input speed of 450 rpm.

How to calculate resonant frequency of the system

Formula 021-3

$$f = \frac{1}{2\pi} \sqrt{\frac{K}{J}}$$

Formula variables

Table 021-2

f	The resonant frequency of the system	Hz	
K	Spring constant	Nm/rad	See pages of each series
J	Load inertia	kgm ²	

Starting Torque

Starting torque is the torque value applied to the input side at which the output first starts to rotate. The values in the table of each series indicate the maximum value, and the lower-limit value indicates approximately $\frac{1}{2}$ to $\frac{1}{3}$ of the maximum value.

Measurement conditions:

No-load, ambient temperature: +20°C _____

■ See the corresponding pages of each series for starting torque values.

* Use the values in the table of each series as reference values as they vary depending on the usage conditions.

Backdriving Torque

Backdriving torque is the torque value applied to the output side at which the input first starts to rotate. The values in the table are maximum values, typical values are approximately $\frac{1}{2}$ of the maximum values.

Note: Never rely on these values as a margin in a system that must hold an external load. A brake must be used where back driving is not permissible.

Measurement conditions:

No-load, ambient temperature: +20°C _____

■ See the corresponding pages of each series for backdriving torque values.

* Use the values in the table of each series as reference values as they vary depending on the usage conditions.

No-Load Running Torque

No-load running torque is the torque which is required to rotate the input side (high speed side), when there is no load on the output side (low speed side). The graph of the no-load running torque shown in this catalog depends on the measurement conditions shown in Table 023-1.

Add the compensation values shown by each series to all reduction ratios except 100:1.

- See the corresponding pages of each series for no-load running torque values.

Measurement condition

Table 023-1

Reduction ratio 100			
Lubricant	Grease lubrication	Name	Harmonic Grease SK-1A
			Harmonic Grease SK-2
		Quantity	(See pages of each series)
Torque value is measured after 2 hours at 2000 rpm input			

* Contact us for oil lubrication.

Efficiency

The efficiency varies depending on the following conditions.

- Reduction ratio
- Input speed
- Load torque
- Temperature
- Lubrication (type and quantity)

The efficiency characteristics of each series shown in this catalog depends on the measurement condition shown in Table 023-2.

- See the corresponding pages of each series for efficiency values.

Efficiency compensation coefficient

If load torque is below rated torque, a compensation factor must be employed. Calculate the compensation coefficient K_e from the efficiency compensation coefficient graph of each series and use the following example for calculation.

Example of calculation

Efficiency η (%) under the following condition is obtained from the example of CSF-20-80-2A-GR.

Input rotational speed: 1000 rpm

Load torque: 19.6 Nm

Lubrication method: Grease lubrication (Harmonic Grease SK-1A)

Lubricant temperature: 20°C

Since the rated torque of size 20 with a reduction ratio of 80 is 34 Nm (Ratings: Page 039), the torque ratio α is 0.58.

($\alpha=19.6/34=0.58$)

- The efficiency compensation coefficient is $K_e=0.93$ from Graph 023-1.
- Efficiency η at load torque 19.6 Nm: $\eta=K_e \cdot \eta_R=0.93 \times 78=73\%$

Measurement condition

Table 023-2

Installation	Based on recommended tolerance		
Load torque	The rated torque shown in the rating table (see the corresponding pages on each series)		
Lubricant	Grease lubrication	Name	Harmonic Grease SK-1A
			Harmonic Grease SK-2
		Quantity	Recommended quantity (see the pages on each series)

* Contact us for oil lubrication.

Efficiency compensation coefficient (CSF series)

Graph 023-1

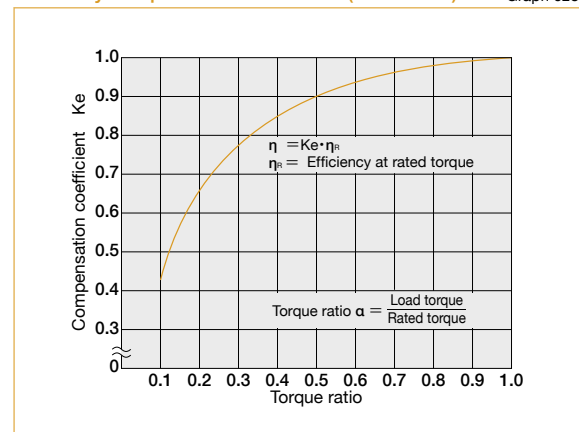

* Efficiency compensation coefficient $K_e=1$ when the load torque is greater than the rated torque.

Design Guidelines

Design guideline

The relative perpendicularity and concentricity of the three basic Harmonic Drive® elements have an important influence on accuracy and service life.

Misalignments will adversely affect performance and reliability. Compliance with recommended assembly tolerances is essential in order for the advantages of Harmonic Drive® gearing to be fully realized. Please consider the following when designing:

- (1) Input shaft, Circular Spline and housing must be concentric.
- (2) When operating, an axial force is generated on the wave generator. Input bearings must be selected to accommodate this axial load. See page 27.
- (3) Even though a HarmonicDrive® gear is compact, it transmits large torques. Therefore, assure that all required bolts are used to fasten the circular spline and flexspline and that they are tightened to the recommended torque.
- (4) As the flexspline is subject to elastic deformation, the A minimal clearance between the flexspline and housing is required. Refer to "Minimum Housing Clearance" on the drawing dimension tables.
- (5) The input shaft and output shaft are supported by anti-friction bearings. As the wave generator and flexspline elements are meant to transmit pure torque only, the bearing arrangement needs to isolate the harmonic gearing from external forces applied to either shaft. A common bearing arrangement is depicted in the diagram.
- (6) A clamping plate is recommended (item 6). Its purpose is to spread fastening forces and to avoid any chance of making physical contact with the thin section of the flexspline diaphragm. The clamping plate shall not exceed the diaphragm's boss diameter and is to be designed in accordance with catalog recommendations.

Fig. 024-1

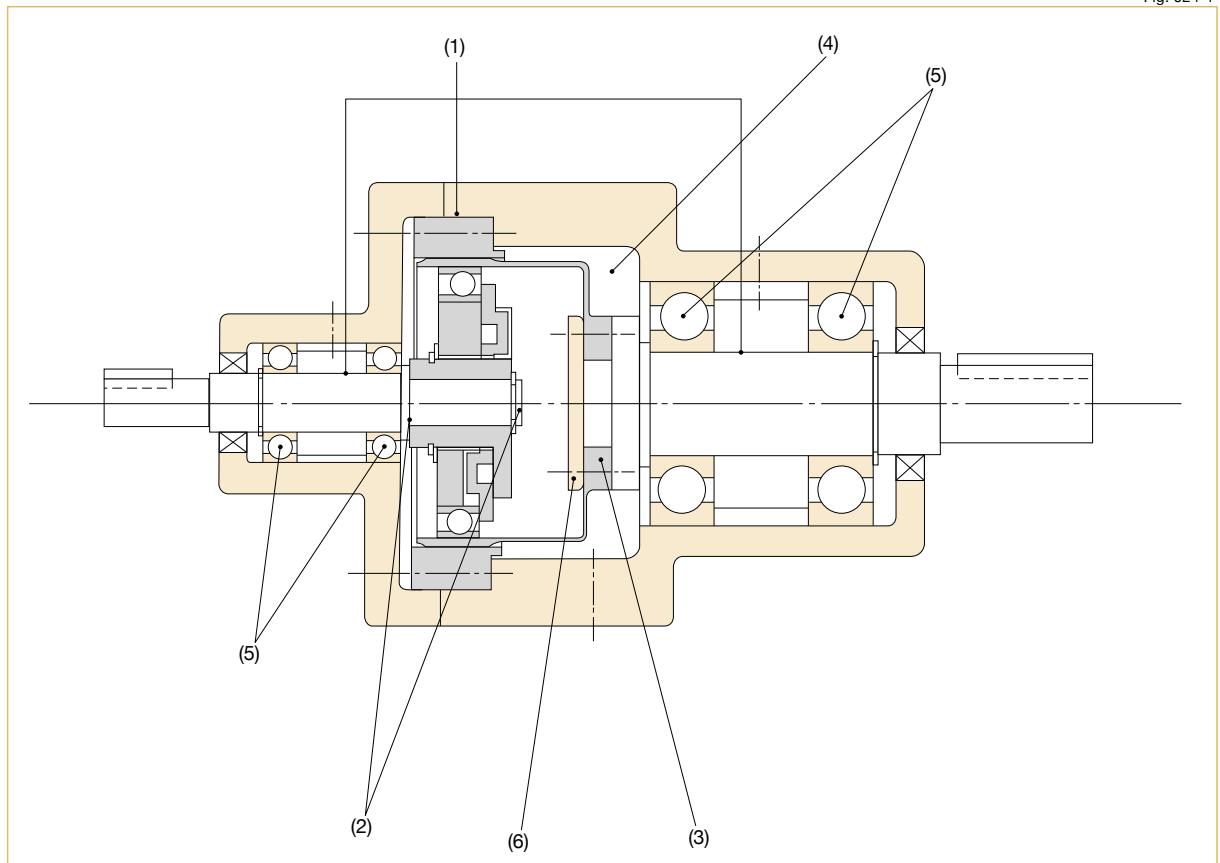

Bearing support for the input and output shafts

For the component sets, both input and output shafts must be supported by two adequately spaced bearings in order to withstand external radial and axial forces without excessive deflection. In order to avoid damage to the component set when limited external loads are anticipated, both input and output shafts must be axially fixed.

Bearings must be selected whose radial play does not exceed ISO-standard C 2 class or "normal" class. The bearings should be axially and radially preloaded to eliminate backlash.

Examples of correct bearing arrangements are shown in fig 025-1.

Fig. 025-1

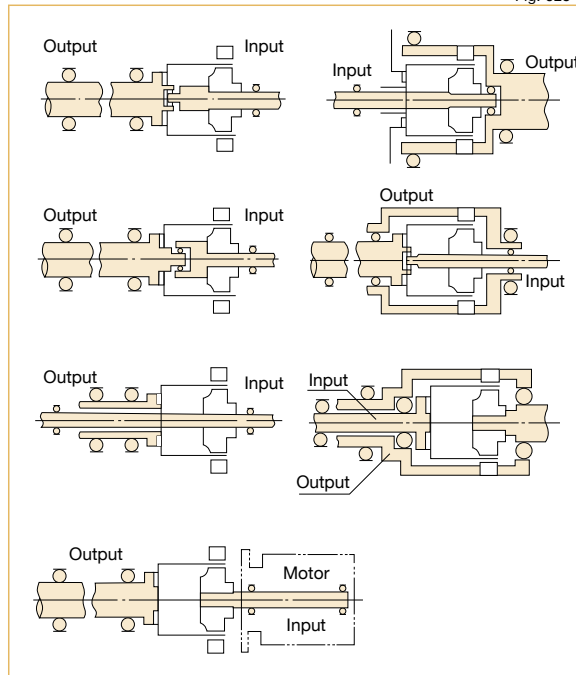

Wave generator

Structure of the wave generator

The wave generator includes an Oldham's coupling type with a self-aligning structure and an integrated solid wave generator without a self-aligning structure, and which is used depends on the series.

See the diagram of each series for details. The basic structure of the wave generator and the shape are shown below.

Fig. 026-1

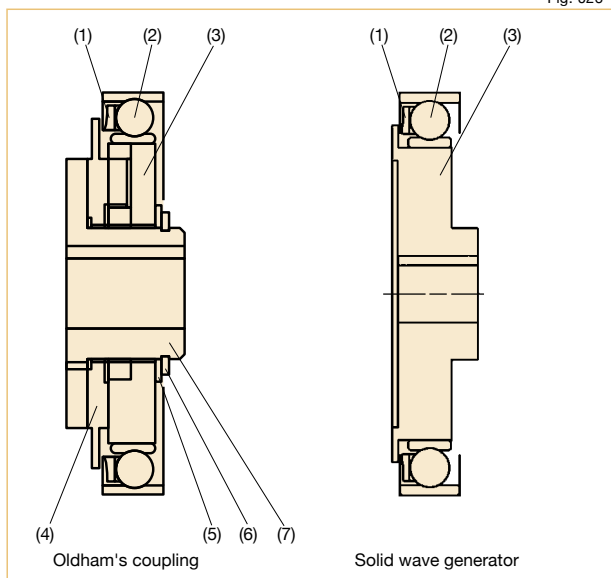

- (1) Ball Separator
- (2) Wave generator bearing
- (3) Wave generator plug
- (4) Insert
- (5) Rubwasher
- (6) Snap ring
- (7) Wave generator hub

Structure of Oldham's coupling

Fig. 026-2

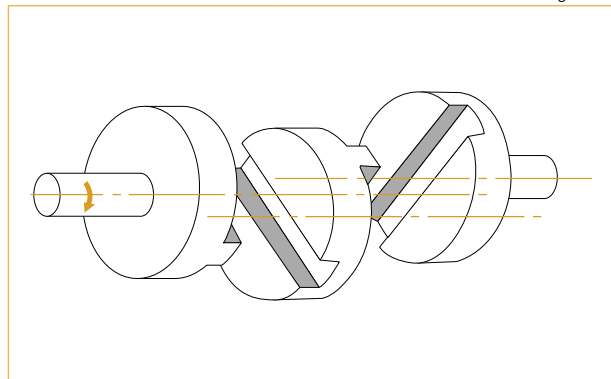

Maximum hole diameter of wave generator

The standard hole dimension of the wave generator is shown for each size. The dimension can be changed within a range up to the maximum hole dimension. We recommend the dimension of keyway based on JIS standard. It is necessary that the dimension of keyways should sustain the transmission torque.

* Tapered holes are also available.

In cases where a larger hole is required, use the wave generator without the Oldham coupling. The maximum diameter of the hole should be considered to prevent deformation of the Wave Generator plug by load torque. The dimension is shown in the table below and includes the dimension of depth of keyway. (This is the value including the dimension of the depth of keyway.)

Hole diameter of the wave generator

Fig. 027-1

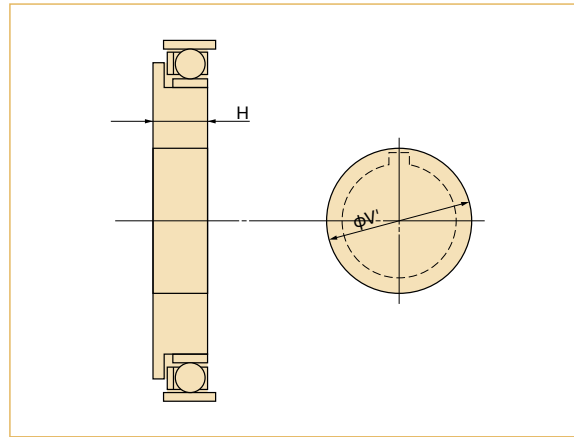

Hole diameter of the wave generator hub with Oldham coupling

Table 027-1
Unit: mm

Size	8	11	14	17	20	25	32	40	45	50	58	65	80	90	100
Standard dim. (H7)	3	5	6	8	9	11	14	14	19	19	22	24	28	28	28
Minimum hole dim.	—	—	3	4	5	6	6	10	10	10	13	16	16	19	22
Maximum hole dim.	—	—	8	10	13	15	15	20	20	20	25	30	35	37	40

Maximum hole diameter without Oldham Coupling

Table 027-2
Unit: mm

Size	8	11	14	17	20	25	32	40	45	50	58	65	80	90	100
Max. hole dia. φV'	10	14	17	20	23	28	36	42	47	52	60	67	72	84	95
Min. plug thick. H _{B,1}	5.7	6.7	7.2	7.6	11.3	11.3	13.7	15.9	17.8	19	21.4	23.5	28.5	31.3	34.9

Axial Force of Wave Generator

When the gear is used to accelerate a load, the deflection of the Flexspline leads to an axial force acting on the Wave Generator. This axial force, which acts in the direction of the closed end of the Flexspline, must be supported by the bearings of the input shaft (motor shaft). When the gear is used to decelerate a load, an axial force acts to push the Wave Generator out of the Flexspline cup. Maximum axial force of the Wave Generator can be calculated by the equation shown below. The axial force may vary depending on its operating condition. The value of axial force tends to be a larger number when using high torque, extreme low speed and constant operation. The force is calculated (approximately) by the equation. In all cases, the Wave Generator must be axially (in both directions), as well as torsionally, fixed to the input shaft.

(Note)
Please contact us for further information on attaching the Wave Generator to the input (motor) shaft.

Axial force direction of the wave generator

Fig. 027-2

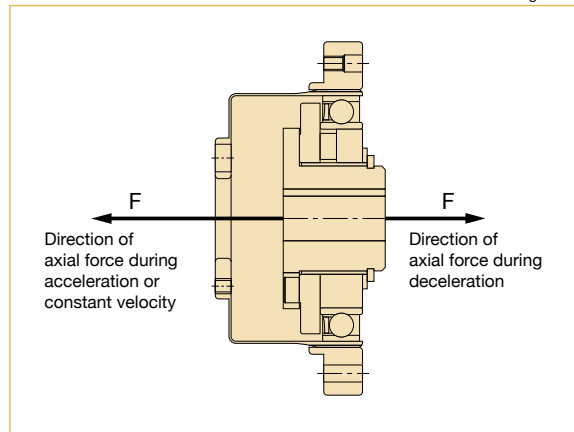

Formula for Axial Force

Table 027-3

Reduction ratio	Calculation formula
30	$F = 2 \times \frac{T}{D} \times 0.07 \times \tan 32^\circ$
50	$F = 2 \times \frac{T}{D} \times 0.07 \times \tan 30^\circ$
80 or more	$F = 2 \times \frac{T}{D} \times 0.07 \times \tan 20^\circ$

Symbols for Formula

Table 027-4

F	Axial force	N	See Figure 027-2
D	Size	m	
T	Output torque	Nm	

Calculation example

Formula 027-1

Model name: CSF series
 Size: 32
 Reduction ratio: 50
 Output torque: 382 Nm
 (maximum allowable momentary torque)

$$F = 2 \times \frac{382}{(32 \times 0.00254)} \times 0.07 \times \tan 30^\circ$$

F = 380N

Assembly Precautions

Sealing

Sealing is needed to maintain the high durability of the gear and prevent grease leakage. Recommended for all mating surfaces, if the o-ring is not used. Flanges provided with o-ring grooves must be sealed when a proper seal cannot be achieved using the o-ring alone.

- Rotating Parts Oil seal with spring is needed.
- Mating flange O-ring or seal adhesive is needed.
- Screw hole area Screws should have a thread lock (LOCTITE® 242 is recommended) or seal adhesive.

(Note) If you use Harmonic Grease 4BNo.2, strict sealing is required.

Sealing recommendations for gear units

Table 028-1

Area requiring sealing		Recommended sealing method
Output side	Holes which penetrate housing	Use O-ring (supplied with the product)
	Installation screw / bolt	Screw lock adhesive which has effective seal (LOCTITE® 242 is recommended)
Input side	Flange surfaces	Use O-ring (supplied with the product)
	Motor output shaft	Please select a motor which has an oil seal on the output shaft.

Assembly precautions

The wave generator is installed after the flexspline and circular spline. If the wave generator is not inserted into the flexspline last, gear teeth scuffing damage or improper eccentric gear mesh may result. Installation resulting in an eccentric tooth mesh (Dedoidal) will cause noise and vibration, and can lead to early failure of the gear. For proper function, the teeth of the flexspline and Circular Spline mesh symmetrically.

■ Precautions on the wave generator

1. Avoid applying undue axial force to the wave generator during installation. Rotating the wave generator bearing while inserting it is recommended and will ease the process.
2. If the wave generator does not have an Oldham coupling, extra care must be given to ensure that concentricity and inclination are within the specified limits

■ Precautions on the circular spline

The circular Spline must not be deformed in any way during the assembly. It is particularly important that the mounting surfaces are prepared correctly

1. Mounting surfaces need to have adequate flatness, smoothness, and no distortion.
2. Especially in the area of the screw holes, burrs or foreign matter should not be present.
3. Adequate relief in the housing corners is needed to prevent interference with the corner of the circular spline.
4. The circular spline should be rotatable within the housing. Be sure there is not interference and that it does not catch on anything.
5. When a bolt is inserted into a bolt hole during installation, make sure that the bolt fits securely and is not in an improper position or inclination.
6. Do not apply torque at recommended torque all at once. First, apply torque at about half of the recommended value to all bolts, then tighten at recommended torque. Order of tightening bolts must be diagonal.
7. Avoid pinning the circular spline if possible as it can reduce the rotational precision and smoothness of operation.

■ Precautions on the flexspline

1. Mounting surfaces need to have adequate flatness, smoothness, and no distortion.
2. Especially in the area of the screw holes, burrs or foreign matter should not be present.
3. Adequate clearance with the housing is needed to ensure no interference especially with the major axis of flexspline
4. Bolts should rotate freely when installing through the mounting holes of the flexspline and should not have any irregularity due to the shaft bolt holes being misaligned or oblique.
5. Do not tighten the bolts with the specified torque all at once. Tighten the bolts temporarily with about half the specified torque, and then tighten them to the specified torque. Tighten them in an even, crisscross pattern.
6. The flexspline and circular spline are concentric after assembly. After installing the wave generator bearing, if it rotates in unbalanced way, check the mounting for dedoidal or non-concentric installation.
7. Care should be taken not to damage the flexspline diaphragm or gear teeth during assembly.
Avoid hitting the tips of the flexpline teeth and circular spline teeth. Avoid installing the CS from the open side of the flexspline after the wave generator has been installed.

■ Rust prevention

Although the Harmonic Drive® gears come with some corrosion protection, the gear can rust if exposed to the environment. The gear external surfaces typically have only a temporary corrosion inhibitor and some oil applied. If an anti-rust product is needed, please contact us to review the options.

"Dedoidal" state

It is normal for the flexspline to engage with the circular spline symmetrically as shown in Figure 029-1. However, if the ratcheting phenomenon, which is described on Page 013, is caused or if the three parts are forcibly inserted and assembled, engagement of the teeth may be out of alignment as shown in Figure 029-2. This is called "dedoidal". Note: Early failure of the gear will occur.

How to check "dedoidal"

By performing the following methods, check whether the gear engagement is "dedoidal".

- (1) Judging by the irregular torque generated when the wave generator turns
 - 1) Slowly turn the input shaft with your hand in a no-load condition. If you can turn it with average force, it is normal. If it turns irregularly, it may be "dedoidal".
 - 2) Turn the wave generator in a no-load condition if it is attached to a motor. If the average current value of the motor is about 2 to 3 times the normal value, it may be "dedoidal".

(2) Judging by measuring vibration on the body of the flexspline

The scale deflection of the dial gauge draws a sine wave as shown by the solid line in Graph 029-3 when it is normally assembled. When "dedoidal" occurs, the gauge draws a deflected wave shown by the dotted line as the flexspline is out of alignment.

Normal engagement status

Fig. 029-1

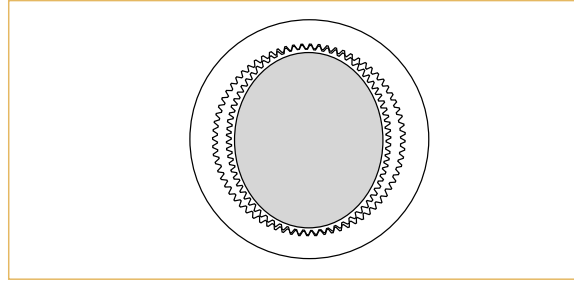

"Dedoidal" status

Fig. 029-2

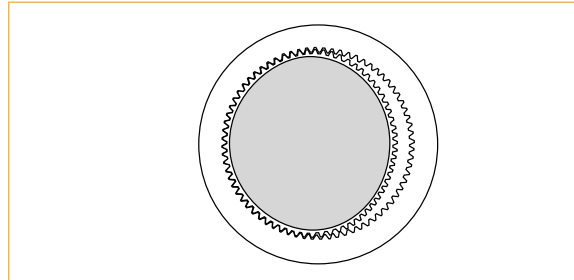

Deflection of the dial gauge

Graph 029-3

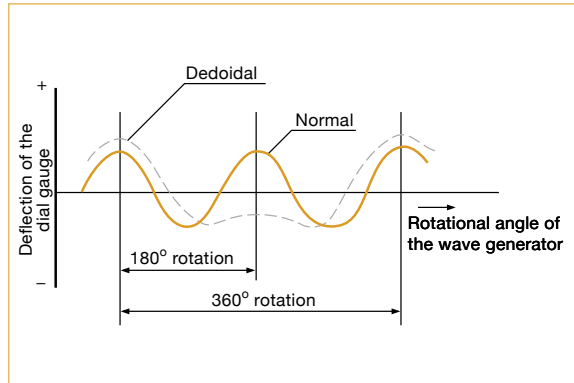

Measuring the deflection on the body of the flexspline

Fig. 029-4

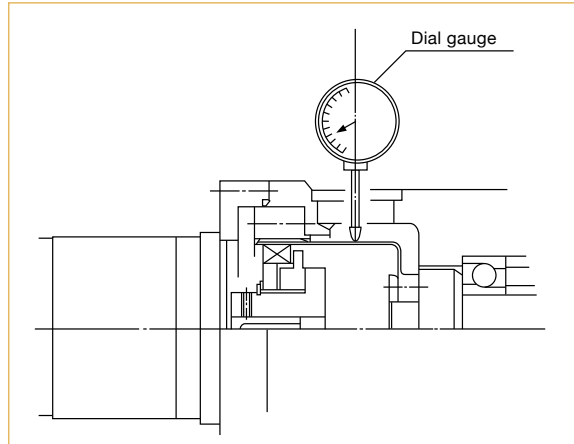

Checking Output Bearing

A precision cross roller bearing is built in the unit type and the gear head type to directly support the external load (output flange) (precision 4-point contact ball bearing for the CSF-mini series). Please calculate maximum moment load, life of cross roller bearing, and static safety factor to fully maximize the performance of a housed unit (gearhead).

■ See the corresponding pages on each series for cross roller bearing specifications.

Checking procedure

(1) Checking the maximum moment load (M_{max})

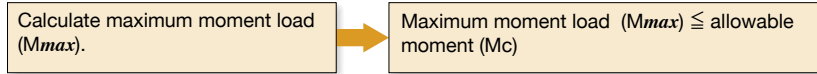

(2) Checking the life

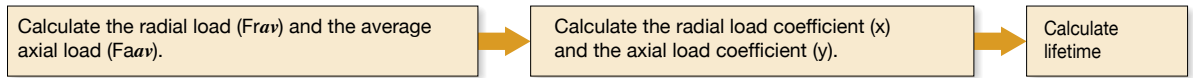

(3) Checking the static safety coefficient



How to calculate the maximum moment load

Maximum moment load (M_{max}) is obtained as follows. Make sure that $M_{max} \leq Mc$.

Formula 030-1

$$M_{max} = Fr_{max} (L_r + R) + Fa_{max} \cdot L_a$$

Symbols for Formula 030-1

Table 030-1

Fr_{max}	Max. radial load	N(kgf)	See Fig. 030-1.
Fa_{max}	Max. axial load	N(kgf)	See Fig. 030-1.
L_r, L_a	—	m	See Fig. 030-1.
R	Offset amount	m	See Fig. 030-1 and "Specification of the output bearing" of each series.

External load influence diagram

Fig. 030-1

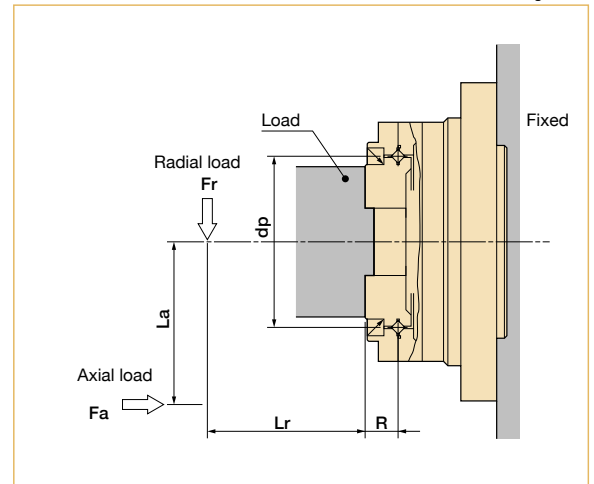

How to calculate the average load

(Average radial load, average axial load, average output speed)

When the radial load and axial load vary, the life of cross roller bearing can be determined by converting to an average load.

How to calculate the average radial load (F_{rav})

Formula 031-1

(Cross roller bearing)

$$F_{rav} = \sqrt[10/3]{\frac{n_1 t_1 (F_{r1})^{10/3} + n_2 t_2 (F_{r2})^{10/3} \dots + n_n t_n (F_{rn})^{10/3}}{n_1 t_1 + n_2 t_2 \dots + n_n t_n}}$$

(4-point contact ball bearing)

$$F_{rav} = \sqrt[3]{\frac{n_1 t_1 (F_{r1})^3 + n_2 t_2 (F_{r2})^3 \dots + n_n t_n (F_{rn})^3}{n_1 t_1 + n_2 t_2 \dots + n_n t_n}}$$

Note that the maximum radial load in t_1 is F_{r1} and the maximum radial load in t_n is F_{rn} .

How to calculate the average axial load (F_{aav})

Formula 031-2

(Cross roller bearing)

$$F_{aav} = \sqrt[10/3]{\frac{n_1 t_1 (F_{a1})^{10/3} + n_2 t_2 (F_{a2})^{10/3} \dots + n_n t_n (F_{an})^{10/3}}{n_1 t_1 + n_2 t_2 \dots + n_n t_n}}$$

(4-point contact ball bearing)

$$F_{aav} = \sqrt[3]{\frac{n_1 t_1 (F_{a1})^3 + n_2 t_2 (F_{a2})^3 \dots + n_n t_n (F_{an})^3}{n_1 t_1 + n_2 t_2 \dots + n_n t_n}}$$

Note that the maximum axial load in t_1 is F_{a1} and the maximum axial load in t_n is F_{an} .

How to calculate the average output speed (N_{av})

Formula 031-3

$$N_{av} = \frac{n_1 t_1 + n_2 t_2 \dots + n_n t_n}{t_1 + t_2 \dots + t_n}$$

Graph 031-1

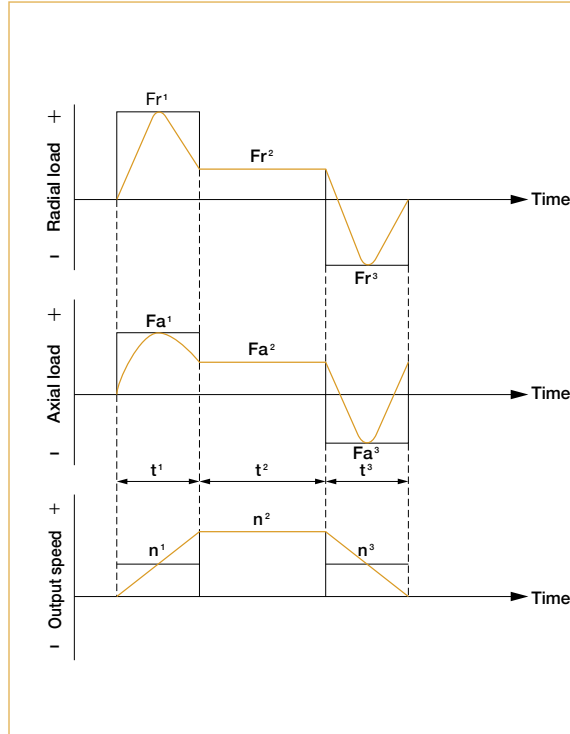

How to calculate the radial load coefficient (X) and axial load coefficient (Y)

Formula 031-4

How to calculate the load coefficient	X	Y
$\frac{F_{aav}}{F_{rav} + 2(F_{rav}(L_r + R) + F_{rav} \cdot L_a) / dp} \leq 1.5$	1	0.45
$\frac{F_{aav}}{F_{rav} + 2(F_{rav}(L_r + R) + F_{rav} \cdot L_a) / dp} > 1.5$	0.67	0.67

Symbols for Formula 031-4

Table 031-1

Symbol	Description	Unit	Reference
F_{rav}	Average radial load	N(kgf)	See "How to calculate the average load." See Formula 031-1.
F_{aav}	Average axial load	N(kgf)	See "How to calculate the average load." See Formula 031-2.
L_r, L_a	_____	m	See fig. 030-1
R	Offset amount	m	See Fig. 030-1 and "Main roller bearing specifications" of each series
dp	Pitch circle diameter of a roller	m	See Fig. 030-1 and "Specification of the output bearing" of each series.

Life of the output bearing

Calculate life of the output bearing by Formula 032-1.
You can calculate the dynamic equivalent radial load (Pc) by Formula 032-2.

Formula 032-1

(Cross roller bearing)

$$L_{10} = \frac{10^6}{60 \times N_{av}} \times \left(\frac{C}{f_w \cdot P_c} \right)^{10/3}$$

(4-point contact ball bearing)

$$L_{10} = \frac{10^6}{60 \times N_{av}} \times \left(\frac{C}{f_w \cdot P_c} \right)^3$$

Formula 032-2

$$P_c = X \cdot \left(F_{rav} + \frac{2(F_{rav}(L_r+R) + F_{rav} \cdot L_a)}{d_p} + Y \cdot F_{aav} \right)$$

Symbols for Formula 032-1

Table 032-1

L ₁₀	Life	hour	---
N _{av}	Average output rated load speed	rpm	See "How to calculate the average load."
C	Basic dynamic rated load	N (kgf)	See "Specification of the output bearing" of each series.
P _c	Dynamic equivalent	N (kgf)	See Formula 032-2.
f _w	Load coefficient	--	See Table 032-3.

Symbols for Formula 032-2

Table 032-2

F _{rav}	Average radial load	N (kgf)	See "How to calculate the average load." See Formula 031-1.
F _{aav}	Average axial load	N (kgf)	See "How to calculate the average load." See Formula 031-2.
d _p	Pitch circle diameter	m	See Fig. 030-1 and "Specification of the output bearing" of each series.
X	Radial load coefficient	--	See Formula 031-4.
Y	Axial load coefficient	--	See Formula 031-4.
L _r , L _a	---	m	See Figure 030-1.
R	Offset	m	See Fig. 030-1 and "Specification of the output bearing" of each series.

Load coefficient

Table 032-3

Load status	f _w
Steady operation without impact and vibration	1 to 1.2
Normal operation	1.2 to 1.5
Operation with impact and vibration	1.5 to 3

How to calculate life during oscillating motion

Calculate the life of the cross roller bearing during oscillating motion by Formula 033-1.

Fig. 033-1

Formula 033-1

(Cross roller bearing)

$$Loc = \frac{10^6}{60 \times n1} \times \frac{90}{\theta} \times \left(\frac{C}{fw \cdot Pc} \right)^{10/3}$$

(4-point contact ball bearing)

$$Loc = \frac{10^6}{60 \times n1} \times \frac{90}{\theta} \times \left(\frac{C}{fw \cdot Pc} \right)^3$$

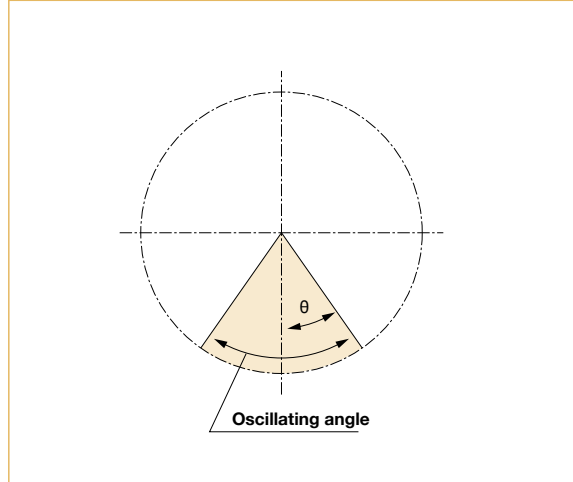

(Note) A small angle of oscillation (less than 5 degrees) may cause fretting corrosion to occur since lubrication may not circulate properly. Contact us if this happens.

Symbols for Formula 033-1

Table 033-1

Loc	Rated life for oscillating motion	hour	---
n1	Round trip oscillation each minute	cpm	---
C	Basic dynamic rated load	N (kgf)	---
Pc	Dynamic equivalent radial load	N (kgf)	See Formula 032-2.
fw	Load coefficient	--	See Table 032-3.
θ	Oscillating angle /2	Degree	See Fig. 033-1.

How to calculate the static safety coefficient

Basic static rated load is an allowable limit for static load, but its limit is determined by usage. In this case, static safety coefficient of the cross roller bearing can be calculated by Formula 034-2.

Formula 034-1

$$f_s = \frac{C_o}{P_o}$$

Formula 034-2

$$P_o = F_{rmax} + \frac{2M_{max}}{d_p} + 0.44F_{a_{max}}$$

Symbols for Formula 034-1

Table 034-1

C_o	Basic static rated load	N(kgf)	See "Specification of the output bearing" of each series.
P_o	Static equivalent radial load	N(kgf)	See Formula 034-2.

Symbols for Formula 034-2

Table 034-2

F_{rmax}	Max. radial load	N(kgf)	See "How to calculate the maximum moment load" on Page 030.
F_{amax}	Max. axial load	N(kgf)	
M_{max}	Max. moment load	Nm(kgfm)	
d_p	Pitch circle diameter of a roller	m	See Fig. 030-1 and "Specification of the output bearing" of each series.

Static Safety Coefficient

Table 034-3

Operating condition of the roller bearing	f_s
When high rotation precision is required	≥ 3
When shock and vibration are expected	≥ 2
Under normal operating condition	≥ 1.5

Harmonic Drive LLC

Boston US Headquarters

247 Lynnfield Street
Peabody, MA 01960

New York Sales Office

100 Motor Parkway
Suite 116
Hauppauge, NY 11788

California Sales Office

333 W. San Carlos Street
Suite 1070
San Jose, CA 95110

Chicago Sales Office

137 N. Oak Park Ave., Suite 410
Oak Park, IL 60301

T: 800.921.3332

T: 978.532.1800

F: 978.532.9406

www.HarmonicDrive.net

Group Companies

Harmonic Drive Systems, Inc.
6-25-3 Minami-Ohi, Shinagawa-ku
Tokyo 141-0013, Japan

Harmonic Drive AG
Hoenbergstrasse, 14, D-6555
Limburg/Lahn Germany

Harmonic Drive®, Harmonic Gearhead®, Harmonic Planetary® and Quick Connect® are registered trademarks of Harmonic Drive LLC. All other trademarks are property of their respective owners.

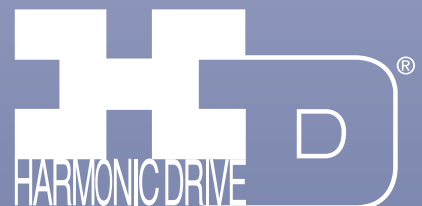

Rev 20190919

Sold & Serviced by:

 **ELECTROMATE**

Toll Free Phone: (877) SERV098
Toll Free Fax: (877) SERV099

www.electromate.com
sales@electromate.com