

Cup Type Component Sets & Housed Units

CSD & SHD
Series

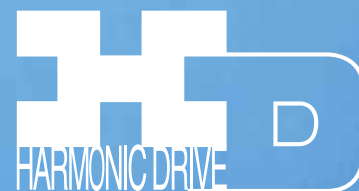
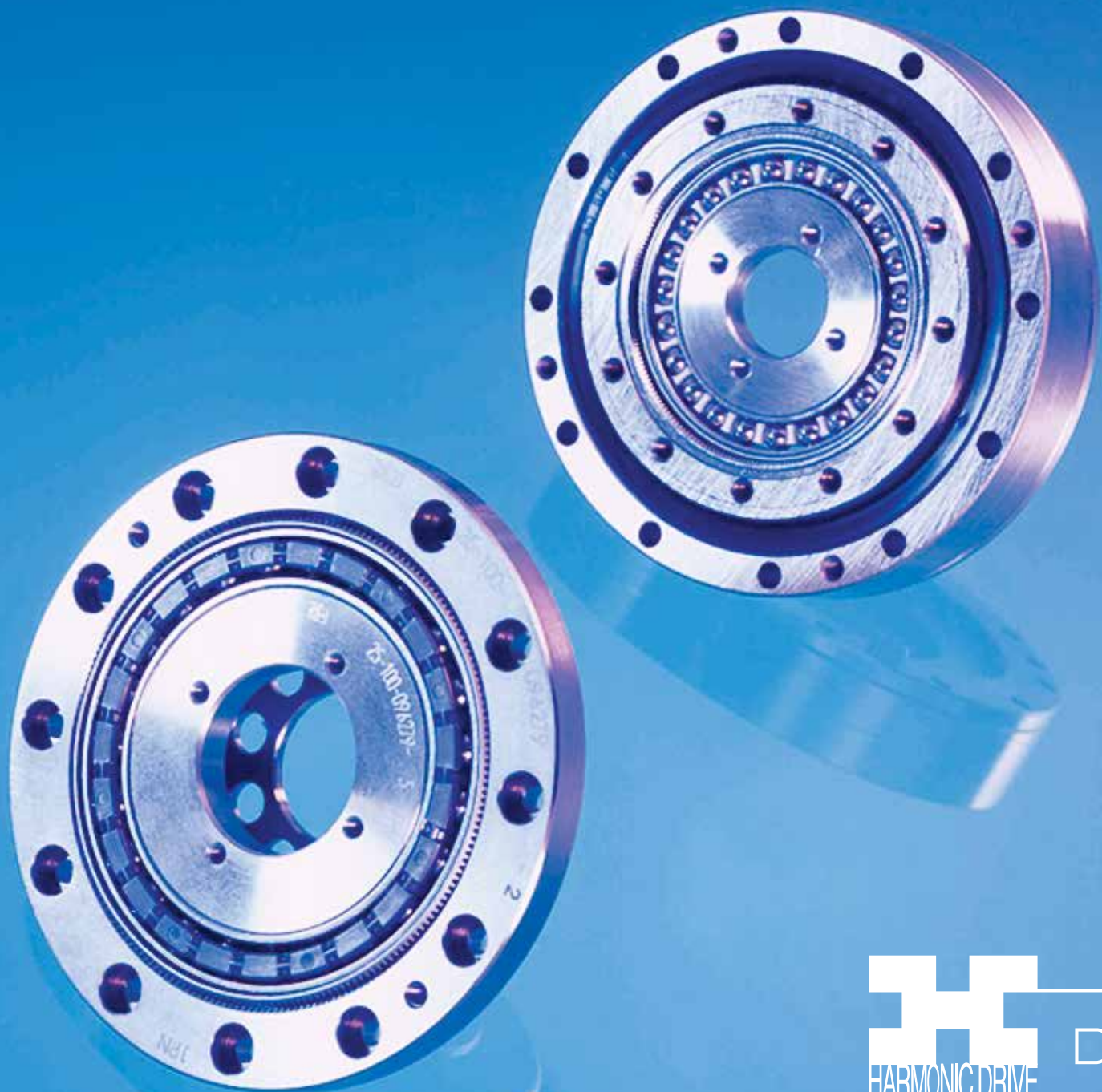

Total Motion Control

Harmonic Drive™ gear

Precision Gearing and Motion Control

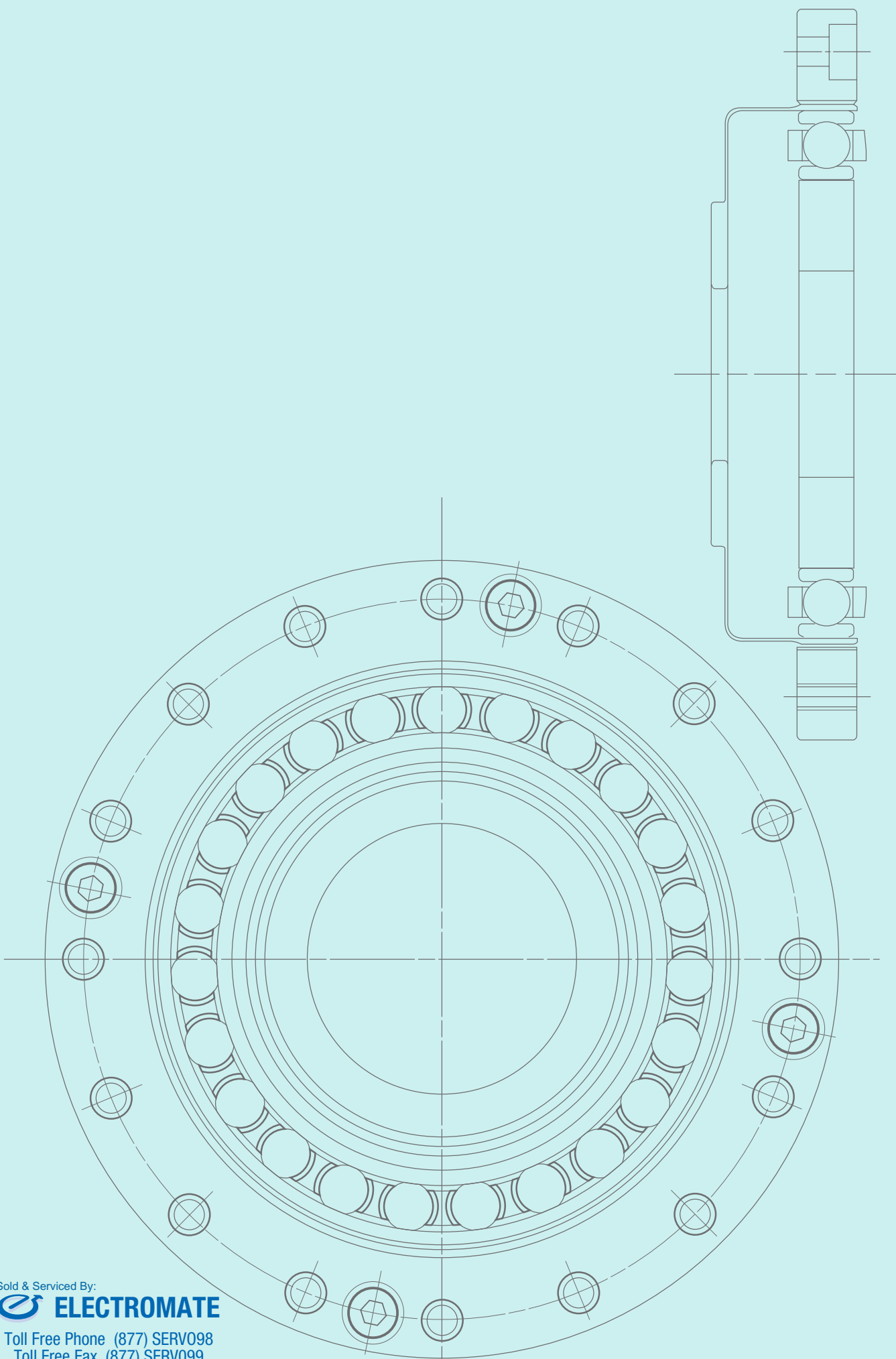

Sold & Serviced By:

 **ELECTROMATE**

Toll Free Phone (877) SERV098

Toll Free Fax (877) SERV099

www.electromate.com

sales@electromate.com

ABOUT HARMONIC DRIVE CSD & SHD	
Ordering Information	4
Harmonic Drive Gearing Mechanism Principle & Structure	5
Driving Configurations	6
Application Examples	7
CSD Rating Table	8
SHD Rating Table	9
Technical Terms, Strength & Life	10
Technical Terms, Life & Torque	11
Selection Procedure & example	12
COMPONENT TYPE CSD	
CSD External Dimension & Shape	14
Lubrication	16
Recommended Tolerances for Assembly	19
Wave Generator Assembly Notes for CSD	20
Assembly of the Flexspline	21
Assembly of the Circular Spline, Assembly Notes	22
CSD Assembly Procedure	23
HOUSED UNIT TYPE SHD	
SHD External Dimensions of Housed Unit	24
Specifications for Cross Roller Bearing	26
Output Bearing Calculations	27
Output Bearing Life	28
Lubrication	29
Recommended Tolerances for Assembly	30
SHD Assembly Notes and Procedure	35
ENGINEERING DATA CSD & SHD	
Efficiency of Component Set	36
Efficiency of Housed Unit	37
No Load Running Torque	38
Starting Torque and Backdriving Torque	40
Positioning Accuracy	41
Torsional Stiffness	41
Hysteresis Loss	43

Sold & Serviced By:

 **ELECTROMATE**

Toll Free Phone (877) SERV098

Toll Free Fax (877) SERV099

www.electromate.comsales@electromate.com

Harmonic Drive LLC 800-921-3332

CSD - 20 - 100 - 2A - GR - SP

Name of Model	Size	Ratio	Model	
CSD	14	50, 100	2A-GR: Component Type (size 14 and 17 are 2A-R)	None: Standard
	17	50, 100		
	20	50, 100, 160		
	25	50, 100, 160		
	32	50, 100, 160		
	40	50, 100, 160		
SHD	14	50, 100	2SH Simplicity Unit Type	BB: Big Bore on Flexspline (CSD Series)
	17	50, 100		
	20	50, 100, 160		
	25	50, 100, 160		
	32	50, 100, 160		
	40	50, 100, 160		

Evolution of Harmonic Drive™ Gear Revolution

Harmonic Drive™ precision gear continues to evolve by improving performance and functionality.

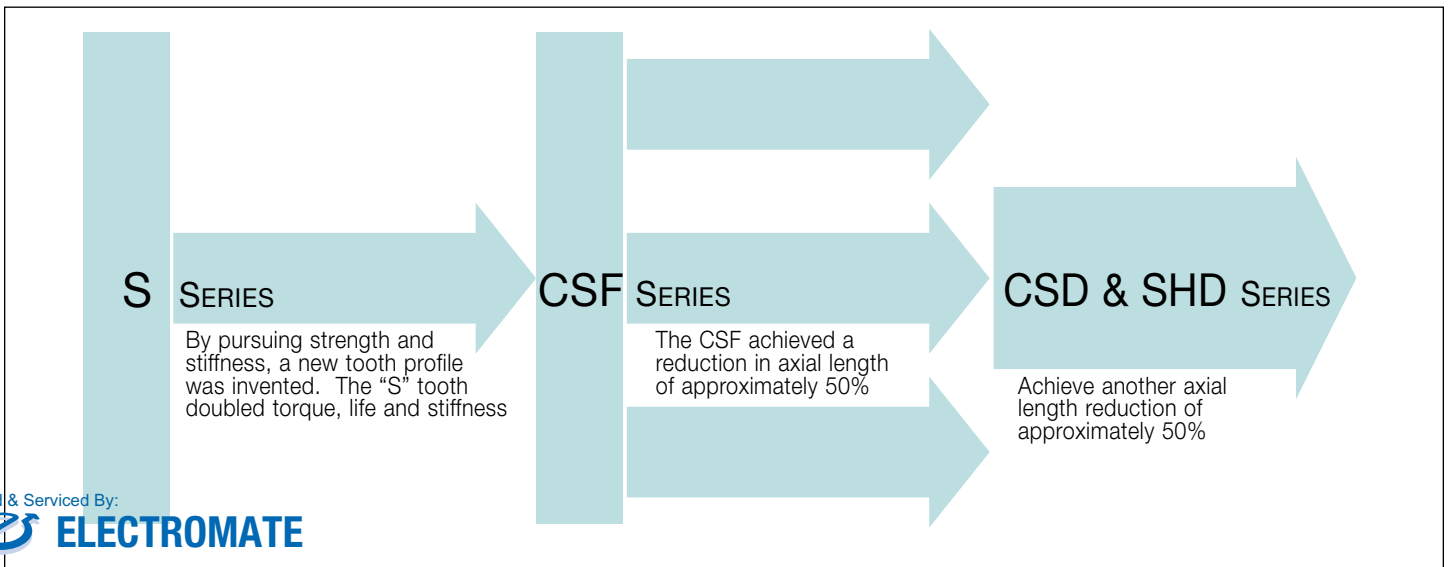

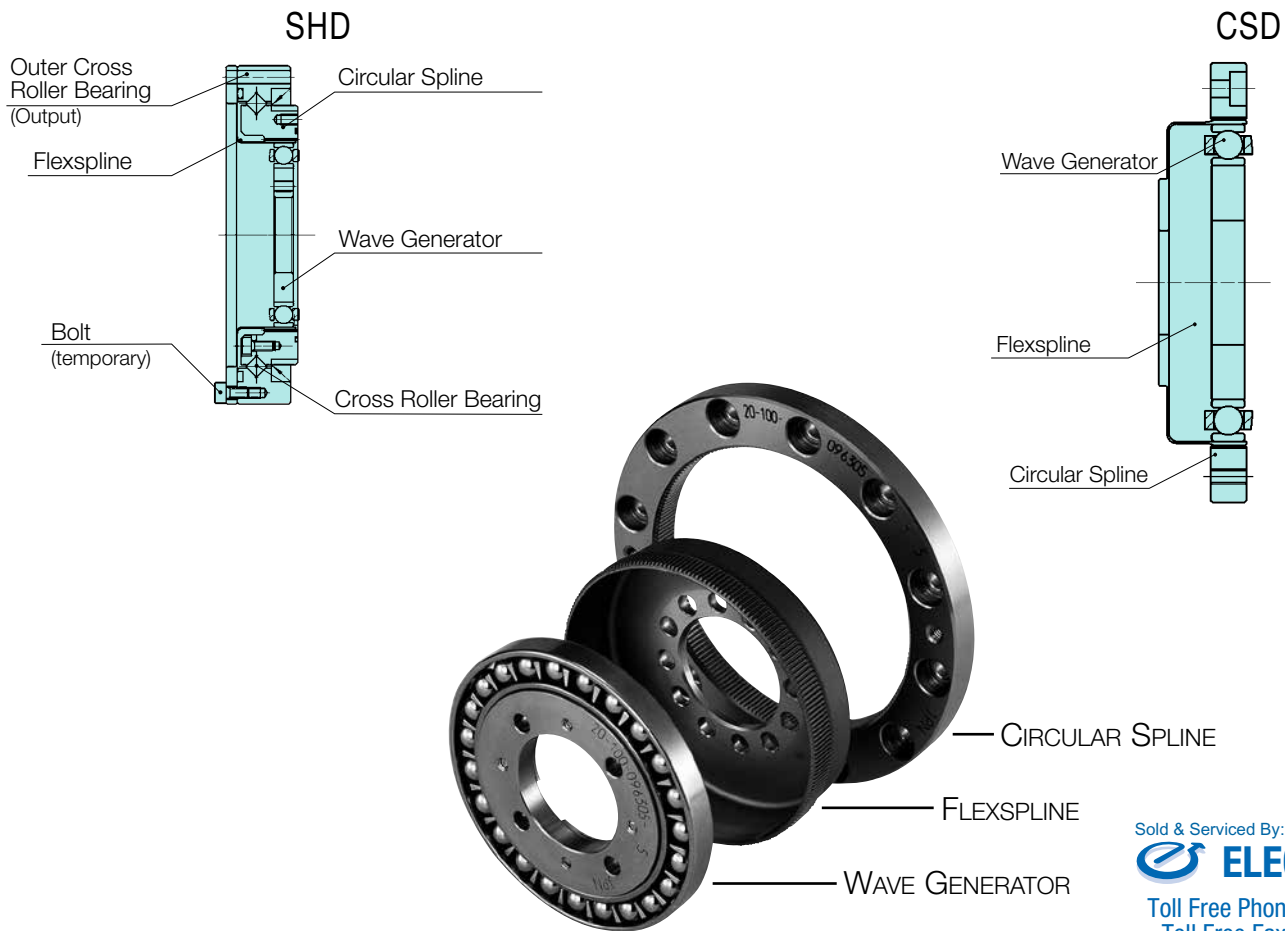

Sold & Serviced By:

 Toll Free Phone (877) SERV098
 Toll Free Fax (877) SERV099
www.electromate.com
sales@electromate.com

System Components

The FLEXSPLINE is a non-rigid, steel cylindrical cup with external teeth on a slightly smaller pitch diameter than the Circular Spline. It fits over and is held in an elliptical shape by the Wave Generator.

The WAVE GENERATOR is a thin raced ball bearing fitted onto an elliptical plug serving as a high efficiency torque converter.

The CIRCULAR SPLINE is a rigid ring with internal teeth, engaging the teeth of the Flexspline across the major axis of the Wave Generator.

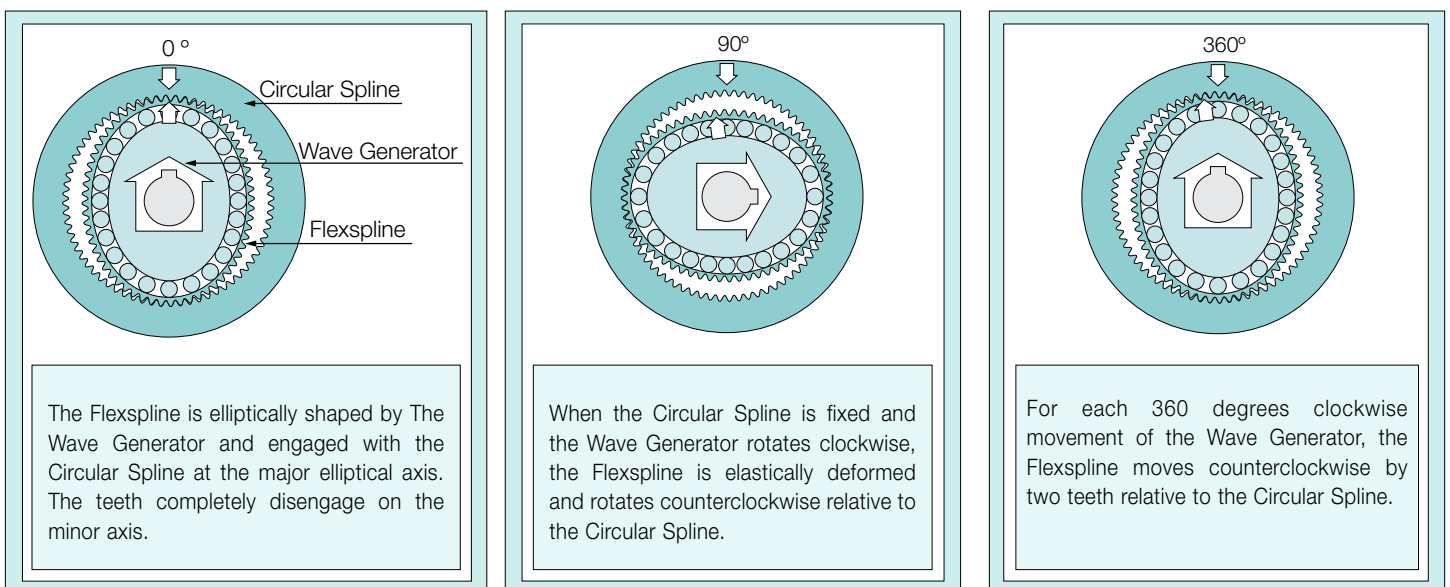

Driving Configurations

Driving Configurations

A variety of different driving configurations are possible, as shown below. The reduction ratio R, given in the tables on page 7 and 8 correspond to arrangement 1, in which the Wave Generator acts as the input element, the Circular Spline is fixed and the Flexspline acts as the output element.

$$\text{Ratio} = \frac{\text{input speed}}{\text{output speed}}$$

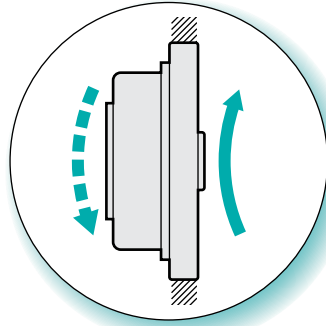

1. Reduction Gearing
 CS Fixed
 WG Input
 FS Output

$$\text{Ratio} = -\frac{R}{1} \quad [\text{Equation 1}]$$

Input and output in opposite direction.

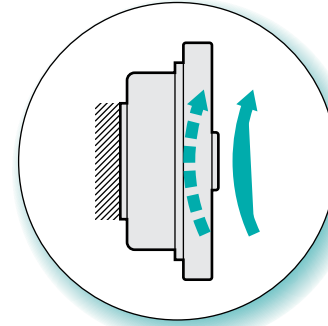

2. Reduction Gearing
 FS Fixed
 WG Input
 CS Output

$$\text{Ratio} = \frac{R+1}{1} \quad [\text{Equation 2}]$$

Input and output in same direction.

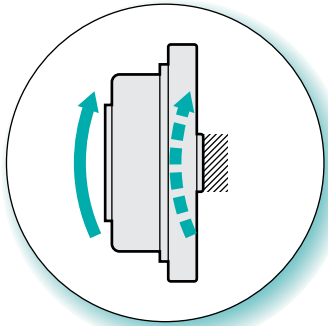

3. Reduction Gearing
 WG Fixed
 FS Input
 CS Output

$$\text{Ratio} = \frac{R+1}{R} \quad [\text{Equation 3}]$$

Input and output in same direction.

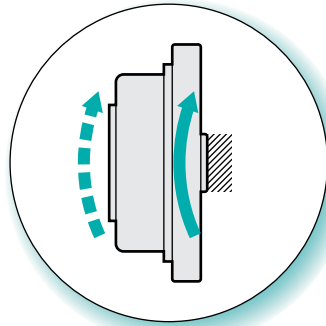

4. Speed Increaser Gearing
 WG Fixed
 CS Input
 FS Output

$$\text{Ratio} = \frac{R}{R+1} \quad [\text{Equation 4}]$$

Input and output in same direction.

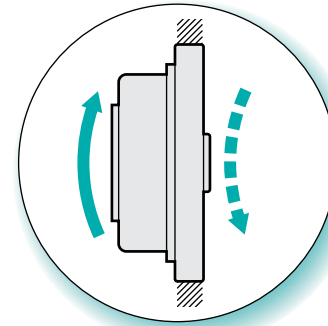

5. Speed Increaser Gearing
 CS Fixed
 FS Input
 WG Output

$$\text{Ratio} = -\frac{1}{R} \quad [\text{Equation 5}]$$

Input and output in opposite direction.

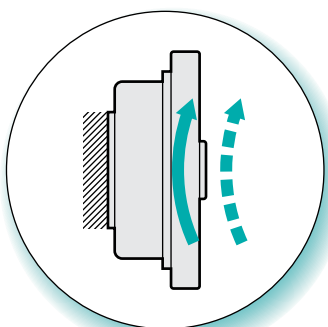

6. Speed Increaser Gearing
 FS Fixed
 CS Input
 WG Output

$$\text{Ratio} = \frac{1}{R+1} \quad [\text{Equation 6}]$$

Input and output in same direction.

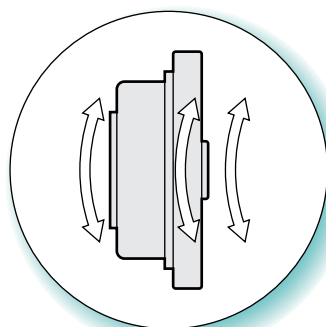

7. Differential Gearing
 WG Control Input
 CS Main Drive-Input
 FS Main Drive-Output

Numerous differential functions can be obtained by combinations of the speed and rotational direction of the three basic elements.

Sold & Serviced By:



Toll Free Phone (877) SERV098

Toll Free Fax (877) SERV099

www.electromate.com

sales@electromate.com

CSD Series

Rotary Table for Machine Tool

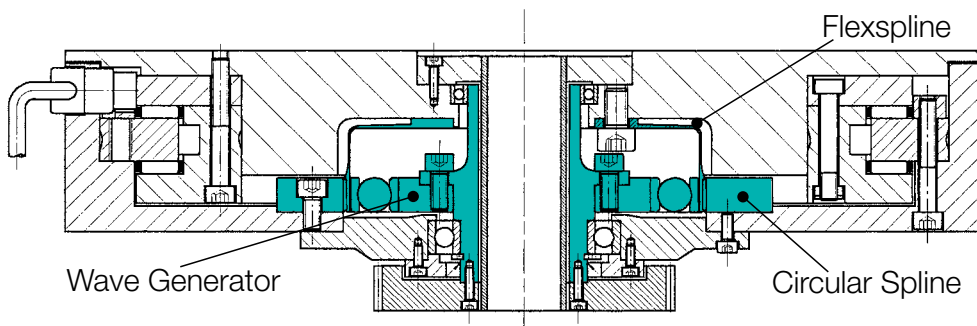

SHD Series

SCARA

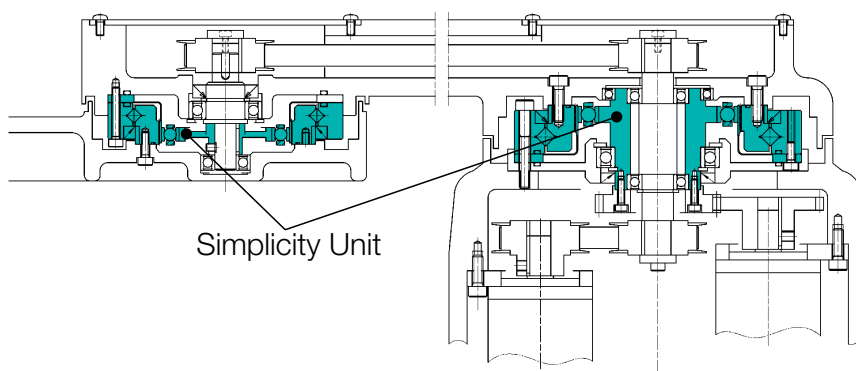

CSD · SHD Series

2 Axis - Output Unit

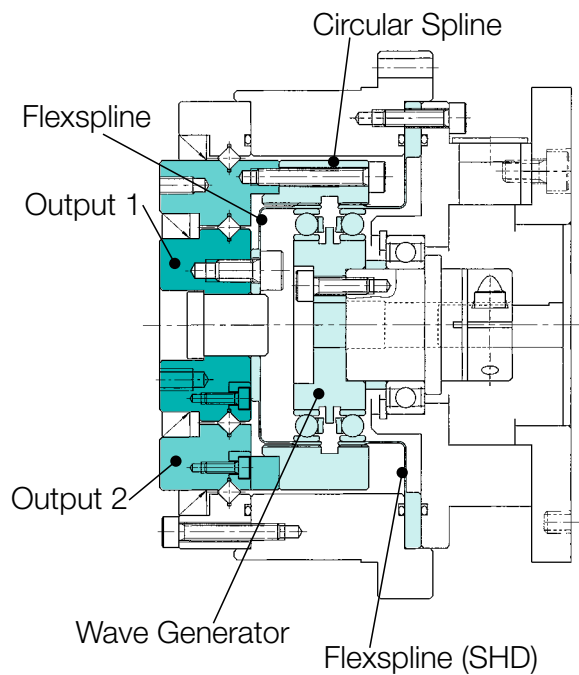

Sold & Serviced By:



Toll Free Phone (877) SERV098

Toll Free Fax (877) SERV099

www.electromate.com

sales@electromate.com

CSD Rating Table

Table 1

ABOUT HARMONIC DRIVE™ GEAR

CSD Size	Gear Ratio R	Rated Torque at 2000 T _r rpm		Limit for Repeated Peak Torque		Limit for Average Torque		Limit for Momentary Peak Torque		Maximum Input Speed		Limit for Average Input Speed		Moment of Inertia			
		Nm	in-lb	Nm	in-lb	Nm	in-lb	Nm	in-lb	rpm	rpm	Oil	Grease	Oil	Grease	I x10 ⁻⁴ kg·m ²	J x10 ⁻⁹ kgf·m·s ²
										Oil	Grease	Oil	Grease				
14	50	3.7	33	12	106	4.8	42	24	212	14000	8500	6500	3500	0.021	0.021		
	100	5.4	48	19	168	7.7	68	31	274								
17	50	11	97	23	204	18	159	48	425	10000	7300	6500	3500	0.054	0.055		
	100	16	142	37	327	27	239	55	487								
20	50	17	150	39	345	24	212	69	611								
	100	28	248	57	504	34	301	76* (65)	673* (575)	10000	6500	6500	3500	0.090	0.092		
	160	28	248	64	566	34	301	76* (65)	673* (575)								
25	50	27	239	69	611	38	336	127 (135)	1124 (1195)								
	100	47	416	110	974	75	664	152* (135)	1345* (1195)	7500	5600	5600	3500	0.282	0.288		
	160	47	416	123	1089	75	664	152* (135)	1345* (1195)								
32	50	53	469	151	1336	75	664	268 (331)	2372 (2929)								
	100	96	850	233	2062	151	1336	359* (331)	3177* (2929)	7000	4800	4600	3500	1.09	1.11		
	160	96	850	261	2310	151	1336	359* (331)	3177* (2929)								
40	50	96	850	281	2487	137	1212	480 (580)	4248 (5133)								
	100	185	1637	398	3522	260	2301	694* (580)	6142* (5133)	5600	4000	3600	3000	2.85	2.91		
	160	206	1823	453	4009	316	2797	694* (580)	6142* (5133)								
50	50	172	1522	500	4425	247	2186	1000 (1315)	8850 (11638)								
	100	329	2912	686	6071	466	4124	1440 (1315)	12744 (11638)	4500	3500	3000	2500	8.61	8.78		
	160	370	3275	823	7284	590	5222	1577* (1315)	13956* (11638)								

Note: The moment of inertia : I=1/4GD², measured at the input

The momentary peak torque is limited by tightening torque on the flexspline.

The values in parenthesis are values in the case of the Big Bore option on the flexspline.

Sold & Serviced By:



Toll Free Phone (877) SERV098

Toll Free Fax (877) SERV099

8 www.electromate.com

sales@electromate.com

SHD Rating Table

Table 2

SHD Size	Ratio R	Rated Torque at 2000 T _r rpm		Limit for Repeated Peak Torque		Limit for Average Torque		Limit for Momentary Peak Torque		Maximum Input Speed rpm Grease	Limit for Average Input Speed rpm Grease	Moment of Inertia																																																																																																																																						
		Nm	in-lb	Nm	in-lb	Nm	in-lb	Nm	in-lb			I x10 ⁴ kg·m ²	J x10 ⁵ kgf·m·s ²																																																																																																																																					
14	50	3.7	33	12	106	4.8	42	23	204	8500	3500	0.021	0.021																																																																																																																																					
	100	5.4	48	19	168	7.7	68	35	310					17	50	11	97	23	204	18	159	48	425	7300	3500	0.054	0.055	100	16	142	37	327	27	239	71	628	20	50	17	150	39	345	24	212	69	611	6500	3500	0.090	0.092	100	28	248	57	504	34	301	95	841	25	50	27	239	69	611	38	336	127	1124	5600	3500	0.282	0.288	100	47	416	110	974	75	664	184	1628	32	50	53	469	151	1336	75	664	268	2372	4800	3500	1.09	1.11	100	96	850	233	2062	151	1336	420	3717	40	50	96	850	281	2487	137	1212	480	4248	4000	3000	2.85	2.91	100	185	1637	398	3522	260	2301	700	6195	40	100	185	1637	398	3522	260	2301	700	6195	4000	3000	2.85	2.91	160	206	1823	453
17	50	11	97	23	204	18	159	48	425	7300	3500	0.054	0.055																																																																																																																																					
	100	16	142	37	327	27	239	71	628					20	50	17	150	39	345	24	212	69	611	6500	3500	0.090	0.092	100	28	248	57	504	34	301	95	841	25	50	27	239	69	611	38	336	127	1124	5600	3500	0.282	0.288	100	47	416	110	974	75	664	184	1628	32	50	53	469	151	1336	75	664	268	2372	4800	3500	1.09	1.11	100	96	850	233	2062	151	1336	420	3717	40	50	96	850	281	2487	137	1212	480	4248	4000	3000	2.85	2.91	100	185	1637	398	3522	260	2301	700	6195	40	100	185	1637	398	3522	260	2301	700	6195	4000	3000	2.85	2.91	160	206	1823	453	4009	316	2797	765	6770																		
20	50	17	150	39	345	24	212	69	611	6500	3500	0.090	0.092																																																																																																																																					
	100	28	248	57	504	34	301	95	841					25	50	27	239	69	611	38	336	127	1124	5600	3500	0.282	0.288	100	47	416	110	974	75	664	184	1628	32	50	53	469	151	1336	75	664	268	2372	4800	3500	1.09	1.11	100	96	850	233	2062	151	1336	420	3717	40	50	96	850	281	2487	137	1212	480	4248	4000	3000	2.85	2.91	100	185	1637	398	3522	260	2301	700	6195	40	100	185	1637	398	3522	260	2301	700	6195	4000	3000	2.85	2.91	160	206	1823	453	4009	316	2797	765	6770																																									
25	50	27	239	69	611	38	336	127	1124	5600	3500	0.282	0.288																																																																																																																																					
	100	47	416	110	974	75	664	184	1628					32	50	53	469	151	1336	75	664	268	2372	4800	3500	1.09	1.11	100	96	850	233	2062	151	1336	420	3717	40	50	96	850	281	2487	137	1212	480	4248	4000	3000	2.85	2.91	100	185	1637	398	3522	260	2301	700	6195	40	100	185	1637	398	3522	260	2301	700	6195	4000	3000	2.85	2.91	160	206	1823	453	4009	316	2797	765	6770																																																																
32	50	53	469	151	1336	75	664	268	2372	4800	3500	1.09	1.11																																																																																																																																					
	100	96	850	233	2062	151	1336	420	3717					40	50	96	850	281	2487	137	1212	480	4248	4000	3000	2.85	2.91	100	185	1637	398	3522	260	2301	700	6195	40	100	185	1637	398	3522	260	2301	700	6195	4000	3000	2.85	2.91	160	206	1823	453	4009	316	2797	765	6770																																																																																							
40	50	96	850	281	2487	137	1212	480	4248	4000	3000	2.85	2.91																																																																																																																																					
	100	185	1637	398	3522	260	2301	700	6195					40	100	185	1637	398	3522	260	2301	700	6195	4000	3000	2.85	2.91	160	206	1823	453	4009	316	2797	765	6770																																																																																																														
40	100	185	1637	398	3522	260	2301	700	6195	4000	3000	2.85	2.91																																																																																																																																					
	160	206	1823	453	4009	316	2797	765	6770																																																																																																																																									

Note: The moment of inertia : I=1/4GD², measured at the input.

Definition of Ratings

Rated Torque (Tr)

Rated torque indicates allowable continuous load torque at 2000 rpm input speed.

Limit for Repeated Peak Torque (refer to figure 1)

During acceleration a deceleration the Harmonic Drive™ gear experiences a peak torque as a result of the moment of inertia of the output load. The table indicates the limit for repeated peak torque.

Limit for Average Torque

In cases where load torque and input speed vary, it is necessary to calculate an average value of load torque. The table indicates the limit for average torque. The average torque calculated must not exceed this limit.

Limit for Momentary Peak Torque (refer to figure 1)

The gear may be subjected to momentary peak torques in the event of a collision or emergency stop. The magnitude and frequency of occurrence of such peak torques must be kept to a minimum and they should, under no circumstance, occur during normal operating cycle. The allowable number of occurrences of the momentary peak torque may be calculated by using equation 1. Also see section "strength and life".

Figure 1

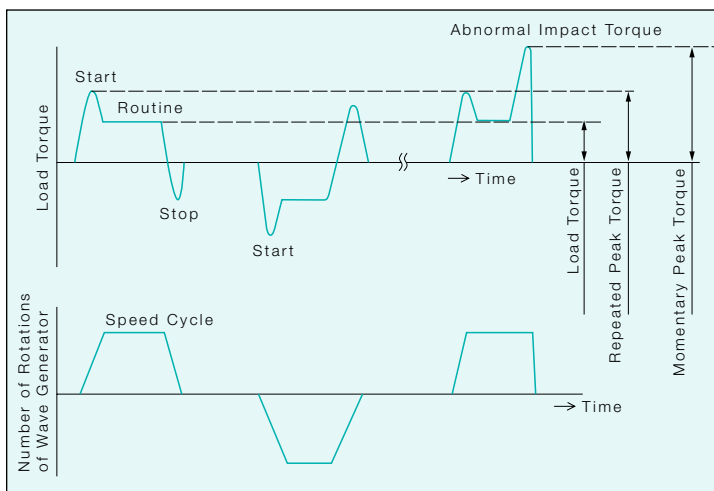

Maximum Input Speed, Limit for average input speed

Do not exceed the allowable rating.

Moment of Inertia

The rating indicates the moment of inertia reflected to the wave generator (gear input).

Strength and Life

The non-rigid Flexspline is subjected to repeated deflections, and its strength determines the torque capacity of the Harmonic Drive™ gear. The values given for Rated Torque at Rated Speed and for the allowable Repeated Peak Torque are based on an infinite fatigue life for the Flexspline.

The torque that occurs during a collision must be below the momentary peak torque (impact torque). The maximum number of occurrences is given by the equation below.

[Equation 1]

$$N = \frac{1.0 \times 10^4}{2 \times \frac{n}{60} \times t}$$

n: Input speed before collision
t: Time interval during collision

Please note:

If this number is exceeded, the Flexspline may experience a fatigue failure.

Ratcheting phenomenon

When excessive torque is applied while the gear is in motion, the teeth between the Circular Spline and Flexspline may not engage properly. This phenomenon is called ratcheting and the torque at which this occurs is called ratcheting torque. Ratcheting may cause the Flexspline to become non-concentric with the Circular Spline. (See figure 1 & 2 on page 12) Operating in this condition may result in shortened life and a Flexspline fatigue failure.

Figure 2

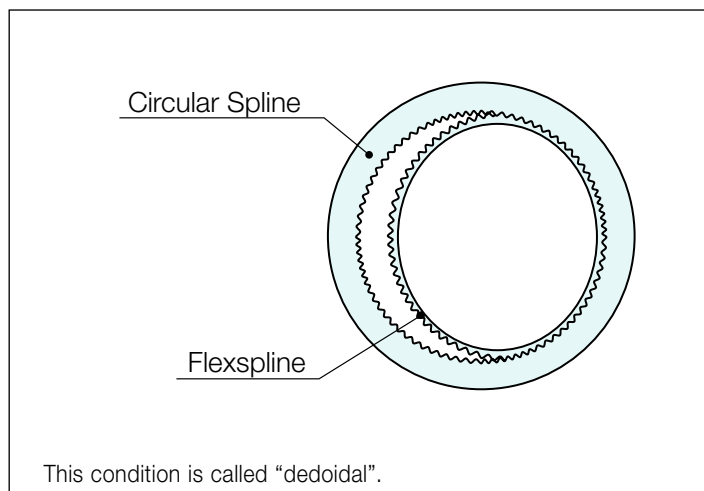

Note!

When ratcheting occurs, the teeth mesh abnormally as shown above. Vibration and Flexspline damage may occur. Once ratcheting occurs, the teeth wear excessively and the ratcheting torque may be lowered.

CSD Ratcheting Torque		Table 3		Nm	
Size	Ratio				
	50	100	160		
14	88	84	-		
17	150	160	-		
20	220	260	220		
25	450	500	450		
32	980	1000	980		
40	1800	2100	1800		
50	3700	4100	3600		

Table 4		Buckling Torque		Nm	
CSD					
Size	All Ratio				
14	190				
17	330				
20	560				
25	1000				
32	2200				
40	4300				
50	8000				

SHD Ratcheting Torque		Table 5		Nm	
Size	Ratio				
	50	100	160		
14	88	84	-		
17	150	160	-		
20	220	260	220		
25	450	500	450		
32	980	1000	980		
40	1800	2100	1800		

Table 6		Buckling Torque		Nm	
SHD					
Size	All Ratio				
14	130				
17	260				
20	470				
25	850				
32	1800				
40	3600				

The Life of a Wave Generator

The normal life of a gear is determined by the life of the wave generator bearing. The life may be calculated by using the input speed and the output load torque.

Rated Lifetime L_n : ($n = 10$ or 50), hours

$$L_{10} \quad \text{CSD,SHD: 7,000}$$

$$L_{50} \quad \text{CSD,SHD: 35,000}$$

Equation for the expected life of the wave generator under normal operating conditions is given by the equation below.

[Equation 2]

$$L_h = L_n \cdot \left(\frac{Tr}{Tav}\right)^3 \cdot \left(\frac{Nr}{Nav}\right)$$

- L_h : Expected Life, hours
- L_n : Rated Lifetime at L_{10} or L_{50} , hours
- Tr : Rated Torque (Tables 1, 2, 3)
- Nr : Rated input speed (2000 rpm)
- Tav : Average load torque on output side (page 14)
- Nav : Average input speed (page 14)

Relative Torque Rating

The chart below shows the various torque specifications relative to rated torque. Rated Torque has been normalized to 1 for comparison.

Figure 3

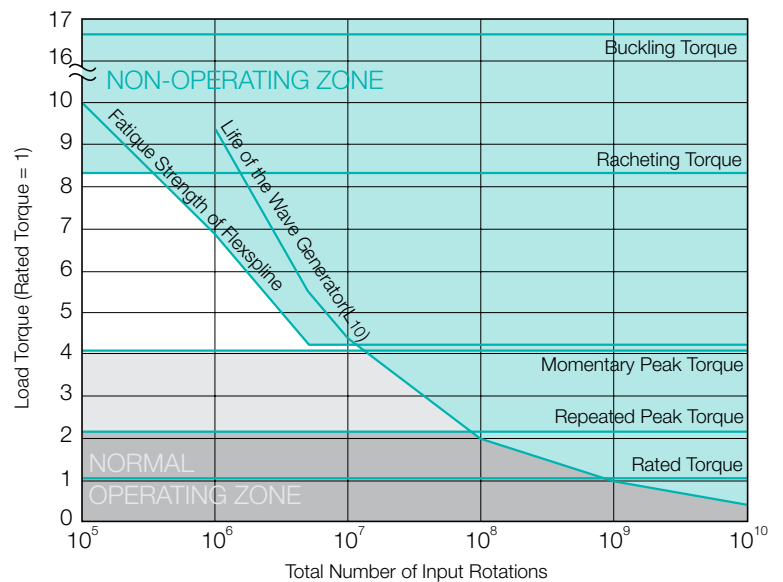

Selection Procedure

Size Selection

Generally, the operating conditions consist of fluctuating torques and output speeds. Also, an unexpected impact output torque must be considered.

The proper size can be determined by converting fluctuating load torque into average load torque and equivalent load torque. This procedure involves selecting the size based on load torque for component sets.

This procedure does not consider the life of the output bearing for housed units. Determining the life of the output bearing for various axial, radial, and moment loads is outlined on page 25.

Figure 4

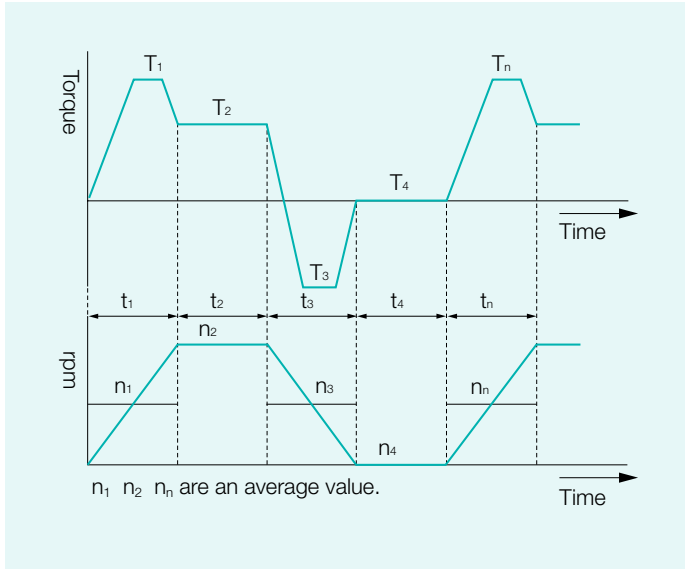

Parameters

Load Torque	T_s (Nm)
Time	t_i (sec)
Output Speed	n_i (rpm)

Normal Operating Pattern

Acceleration	$T_1 \cdot t_1 \cdot n_1$
Regular Operation	$T_2 \cdot t_2 \cdot n_2$
Deceleration	$T_3 \cdot t_3 \cdot n_3$
Dwell	$T_4 \cdot t_4 \cdot n_4$

Maximum RPM

Max output speed	n_o maximum
Max input speed	n_i maximum

Impact Torque	$T_s \cdot t_s \cdot n_s$
---------------	---------------------------

Ratings

Rated Torque	T_r
Rated Speed	$n_r = 2000$ rpm

Flow Chart for selecting a size

Please use the flowchart shown below for selecting a size. Operating conditions must not exceed the performance ratings as described on page 12.

Calculation of the average output torque

$$T_{av} = 3 \sqrt{\frac{n_1 \cdot t_1 \cdot |T_1|^3 + n_2 \cdot t_2 \cdot |T_2|^3 + \dots + n_n \cdot t_n \cdot |T_n|^3}{n_1 \cdot t_1 + n_2 \cdot t_2 + \dots + n_n \cdot t_n}}$$

Selection of tentative size under the condition shown below.

Average Output Speed

$$n_o \text{ av} = \frac{n_1 \cdot t_1 + n_2 \cdot t_2 + \dots + n_n \cdot t_n}{t_1 + t_2 + \dots + t_n}$$

Determine Gear Ratio

$$\frac{n_i \text{ max}}{n_o \text{ max}} \leq R$$

n_i max may be limited by the motor.

Calculation of the average input speed

$$n_i \text{ av} = n_o \text{ av} \cdot R$$

Calculation of maximum input speed
 $n_i \text{ max} = n_o \text{ max} \cdot R$

NG

$n_i \text{ av} \leq$ Limit for average speed
 $n_i \text{ max} \leq$ Limit for maximum speed

OK

NG

Confirm if T_1 and T_3 are less than the repeated peak torque specification.

OK

NG

Confirm if T_s (impact torque) is less than the momentary peak torque specification.

OK

NG

Calculate the allowable number of rotations during impact torque.

$$N_s = \frac{10^4}{2 \cdot \frac{n_s \cdot R}{60} \cdot t_s} \dots \dots N_s \leq 1.0 \times 10^4$$

OK

Calculate wave generator life.

$$L_r = L_r \cdot \left(\frac{T_r}{T_{av}}\right)^3 \cdot \left(\frac{n_r}{n_i \text{ av}}\right)$$

NG

Make sure that the calculated life is suitable for the application.

OK

Gear is suitable for torque and speed requirements

Consider a different size or change operating requirements

Also consider output bearing, environment, etc.

Sold & Serviced By:



Toll Free Phone (877) SERV098

Toll Free Fax (877) SERV099

12 www.electromate.com

sales@electromate.com

Values of an each Load Torque Pattern

Load Torque	T_n (Nm)	no max = 14 rpm
Time	t_n (sec)	n_i max = 1800 rpm
Output Speed	n_n (rpm)	

Normal Operating Pattern

Acceleration	$T_1 = 400$ Nm, $t_1 = 0.3$ sec, $n_1 = 7$ rpm	$T_s = 500$ Nm, $t_s = 0.15$ sec, $n_s = 14$ rpm
Regular Operation Stop	$T_2 = 320$ Nm, $t_2 = 3$ sec, $n_2 = 14$ rpm	
Deceleration	$T_3 = 200$ Nm, $t_3 = 0.4$ sec, $n_3 = 7$ rpm	$L_{10} > 7000$ hrs.
Dwell	$T_4 = 0$ Nm, $t_4 = 0.2$ sec, $n_4 = 0$ rpm	Oil Lubrication

T_{av} (Nm)

$$T_{av} = \sqrt[3]{\frac{7\text{rpm} \cdot 0.3\text{sec} \cdot |400\text{Nm}|^3 + 14\text{rpm} \cdot 3\text{sec} \cdot |320\text{Nm}|^3 + 7\text{rpm} \cdot 0.4\text{sec} \cdot |200\text{Nm}|^3}{7\text{rpm} \cdot 0.3\text{sec} + 14\text{rpm} \cdot 3\text{sec} + 7\text{rpm} \cdot 0.4\text{sec}}}$$

$T_{av} = 319\text{Nm} < 466\text{Nm}$ (for CSD-50-100-2A-GR)

no av (rpm)

$$\frac{7\text{rpm} \cdot 0.3\text{sec} + 14\text{rpm} \cdot 3\text{sec} + 7\text{rpm} \cdot 0.4\text{sec}}{0.3\text{sec} + 3\text{sec} + 0.4\text{sec} + 0.2\text{sec}} = 12 \text{ rpm}$$

(R)

$$\frac{1800 \text{ RPM}}{14 \text{ rpm}} = 128.6 > 100$$

$$n_i \text{ av} = 12\text{rpm} \cdot 100 = 1200\text{rpm}$$

$$n_o \text{ max} \quad n_i \text{ max (rpm)}$$

$$n_i \text{ max} = 14\text{rpm} \cdot 100 = 1400\text{rpm}$$

$n_i \text{ av} = 1440\text{rpm} < 3600\text{rpm}$ (for CSD-50-100-2A-GR)
 $n_i \text{ max} = 1680\text{rpm} < 5600\text{rpm}$ (for CSD-50-100-2A-GR)

NG

Confirm that T1 and T3 are within a

OK

T_1, T_3 (Nm)

$T_1 = 400\text{Nm} < 686\text{Nm}$ (for CSD-50-100-2A-GR)

$T_3 = 200\text{Nm} < 686\text{Nm}$ (for CSD-50-100-2A-GR)

NG

OK

T_s (Nm)

$T_s = 500\text{Nm} < 1440\text{Nm}$ (for CSD-50-100-2A-GR)

NG

OK

N_s Calculate an allowable number of rotation(N_s) and confirm $\leq 1.0 \times 10^4$

$$N_s = \frac{10^4}{2 \cdot \frac{14\text{rpm} \cdot 100}{60} \cdot 0.15} \quad N_s = 1429 < 1.0 \times 10^4$$

NG

OK

Calculate a life time.

$$L_{10} = 7000 \frac{(329\text{Nm})^3}{1319\text{Nm}} \cdot \frac{(2000\text{rpm})}{1440\text{rpm}}$$

$L_{10} = 10665 > 7000$ (L_{B10})

NG

OK

Consider a different size or change operating requirements

Sold & Serviced By:



CSD-50-100-2A-GR

Toll Free Phone (877) SERV098
 Toll Free Fax (877) SERV099
www.electromate.com
sales@electromate.com

CSD Dimensions		Table 7							unit: (mm)
Size	14	17	20	25	32	40	50		
∅A h7	50 ⁰ _{-0.025}	60 ⁰ _{-0.030}	70 ⁰ _{-0.030}	85 ⁰ _{-0.035}	110 ⁰ _{-0.035}	135 ⁰ _{-0.040}	170 ⁰ _{-0.040}		
∅BH7	11 ^{+0.018} ₀	15 ^{+0.018} ₀	20 ^{+0.021} ₀	24 ^{+0.021} ₀	32 ^{+0.025} ₀	40 ^{+0.025} ₀	50 ^{+0.025} ₀		
C	11	12.5	14	17	22	27	33		
D	6.5 ^{+0.2} ₀	7.5 ^{+0.2} ₀	8 ^{+0.3} ₀	10 ^{+0.3} ₀	13 ^{+0.3} ₀	16 ^{+0.3} ₀	19.5 ^{+0.3} ₀		
E	1.4	1.7	2	2	2.5	3	3.5		
F	4.5	5	6	7	9	11	13.5		
G1	0.3	0.3	0.3	0.4	0.5	0.6	0.8		
H	4	5	5.2	6.3	8.6	10.3	12.7		
∅J	23	27.2	32	40	52	64	80		
∅K H6	11 ^{+0.011} ₀	11 ^{+0.011} ₀	16 ^{+0.011} ₀	20 ^{+0.013} ₀	30 ^{+0.013} ₀	32 ^{+0.016} ₀	44 ^{+0.016} ₀		
L	6	8	12	12	12	12	12		
∅M	3.4	3.4	3.4	3.4	4.5	5.5	6.6		
N	M3	M3	M3	M3	M4	M5	M6		
O	-	-	3.3	3.3	4.4	5.4	6.5		
∅P	-	-	6.5	6.5	8	9.5	11		
∅Q	44	54	62	75	100	120	150		
∅R	17	21	26	30	40	50	60		
S	M3	M3	M3	M3	M4	M5	M6		
∅T	17	19.5	24	30	41	48	62		
U	9	8	9	9	11	10	11		
∅V	3.4	4.5	4.5	5.5	6.6	9	11		
∅Z ₁	0.2	0.2	0.2	0.2	0.25	0.25	0.3		
∅Z ₂	0.25	0.25	0.2	0.2	0.25	0.25	0.3		
∅Z ₃	0.2	0.25	0.25	0.25	0.3	0.5	0.5		
Minimum housing clearance	∅a	38	45	53	66	86	106	133	
	b	6.5	7.5	8	10	13	16	19.5	
	c	1	1	1.5	1.5	2	2.5	3.5	
weight (kg)	0.06	0.10	0.13	0.24	0.51	0.92	1.9		

Weight

Note: Standard dimension for size 14 and 17 is the maximum bore.

Dimensions for BB		Table 8					unit:mm
Size	20	25	32	40	50		
∅ KH6	20 ^{+0.013} ₀	24 ^{+0.013} ₀	32 ^{+0.016} ₀	40 ^{+0.016} ₀	50 ^{+0.016} ₀		
U	12	12	14	14			
∅ V	3.4	4.5	5.5	6.6	9		
∅ T	26	32	42	52	65		
∅ Z ₁	0.2	0.25	0.25	0.3	0.5		

Note: Standard dimension for size 14 and 17 is the maximum bore.

- Installed surface on Circular Spline is shown as A. Use this surface for installation in case.
- Dimensions shown below may be modified as a special order.
 - B: Dimension of Wave generator
 - U and V: Dimension of Flexspline
 - L and M: Dimension of Circular spline
- Dimensions for C•D•G must meet the tolerance values shown above.
- ∅a, b, c must exceed the values shown above due to deformation of the flexspline.

Lubricant

Grease lubricant is the standard for the CSD unit. The temperature range is shown below. (Exceptions are shown on page 17.)

Lubricant			Lubricant		
Grease	Harmonic Grease	SK-1A	Grease	SK-1A	0°C~+40°C
Grease	Harmonic Grease	SK-2	Grease	SK-2	0°C~+40°C
Grease	Harmonic Grease	4B-No.2	Grease	4B-No.2	-10°C~+70°C
Oil	Industrial gear oil #2(high pressure)	ISO VG68	Oil	ISO VG68	0°C~+40°C

Harmonic Grease SK-1A

This grease is developed for a Harmonic Drive™ gear and features good durability and efficiency.

Harmonic Grease SK-2

This grease is developed for a small size Harmonic Drive™ gear and features smooth rotation of the Wave Generator since high pressure additive is liquefied.

Harmonic Grease 4BNo.2

This grease is developed for Harmonic Drive™ gear and features long life and a wide range of temperature.

Note 1

Grease lubrication must have proper sealing, this is essential for 4B No.2.

Rotating part: Oil seal with spring is needed.

Mating part: O ring or seal adhesive is needed.

Note 2

The grease has the highest deterioration rate in the region where the grease is subjected to the greatest shear (near wave generator). Its viscosity is between JIS No.0 and No.00 depending on the operation.

Recommended Grease

Size	14	17	20	25	32	40	50
SK-1A	—	—	O	O	O	O	O
SK-2	O	O	Δ	Δ	Δ	Δ	—
4BNo.2	•	•	•	•	•	•	•

•: recommended grease for long life and high load O: Standard Δ: Semistandard

Characteristics of Grease

Grease	SK-1A	SK-2	4BNo.2
Durability	O	O	•
Fretting Resistance	O	O	•
Low Temp	Δ	Δ	•
Grease Leakage	•	•	Δ

•: Excellent O: Good Δ: Exercise Caution

Recommended Grease

Grease	SK-1A	SK-2	4B No.2
Base Oil	Refined mineral hydrocarbon base oil	Refined mineral hydrocarbon base oil	Hydrocarbon type synthetic oil and polymer
Thickening Agent	Lithium soap thickener	Lithium soap thickener	Urea
Additive	Organic molybdenum, etc.	Organic molybdenum, etc.	Organic molybdenum, etc.s
NLGI Consistency No.	No.2	No.2	No.1.5
Viscosity (25C) cSt	265 to 295	265 to 295	290 to 320
Melting Point	197°C	198°C	247°C
Color	Yellow	Green	Light Yellow
Life	5 Years in Airtight Container		



Toll Free Phone (877) SERV098
 Toll Free Fax (877) SERV099
www.electromate.com
sales@electromate.com

Recommended Dimensions for Inner Case

Recommended dimensions for inner case must meet with numbers shown below. These dimensions must be maintained to prevent damage to the gear and to maintain a proper grease cavity.

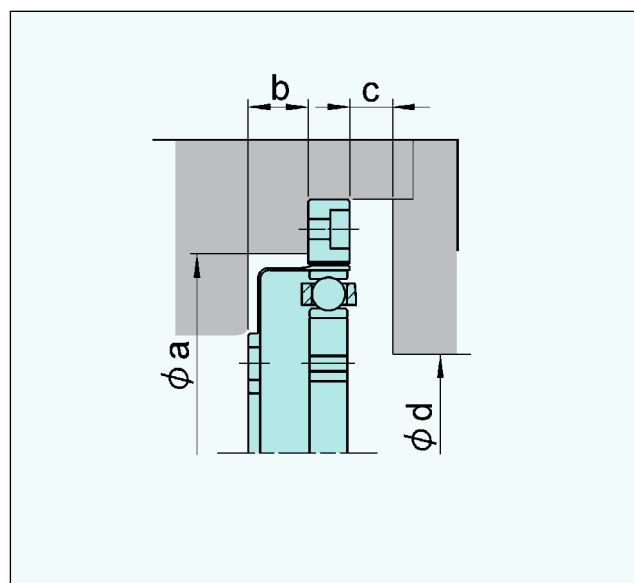

Figure 4

Recommended Dimensions for Inner Case Table 9

Unit: mm

Size	14	17	20	25	32	40	50
ϕa	38	45	53	66	86	106	133
b	6.5	7.5	8	10	13	16	19.5
c	1(3)	1(3)	1.5(4.5)	1.5(4.5)	2(6)	2.5(7.5)	3.5
$\phi d^{+0.5}_0$	16	26	30	37	37	45	45

Note: Values in parenthesis show the value when the Wave Generator is pointing up.

Figure 5

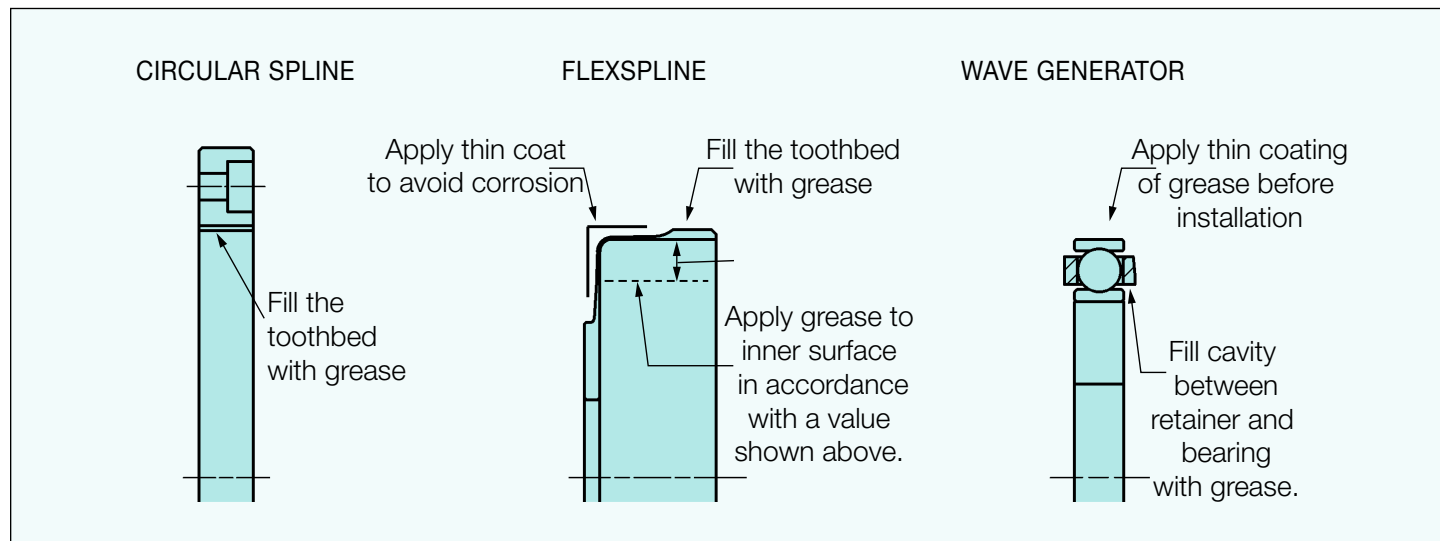

Grease Usage Table 10

Unit: g

Size	14	17	20	25	32	40	50
amount	3.5	5.2	9.0	17	37	68	131

Sold & Serviced By:



Toll Free Phone (877) SERV098
 Toll Free Fax (877) SERV099
www.electromate.com
sales@electromate.com

Grease Change

The wear characteristics of the gear is strongly influenced by the condition of the grease lubrication. The condition of the grease is affected by the ambient temperature. The graph shows the maximum number of input rotations for various temperatures. This graph applies to applications where the average load torque does not exceed the rated torque.

In cases where the average load torque exceeds rated torque, calculate the grease change interval using the equation shown below.

Equation where average load torque exceeds rated torque
[Equation [3]]

$$L_{GT} = L_{GTn} \times \left(\frac{T_r}{T_{av}} \right)^3$$

Symbol of Equation [2]	
L_{GT}	Grease change (average torque is over rated torque), input rotations
L_{GTn}	Grease change (average torque is below rated torque), input rotations (From Graph)
T_r	Rated Torque
T_{av}	Average load torque on output

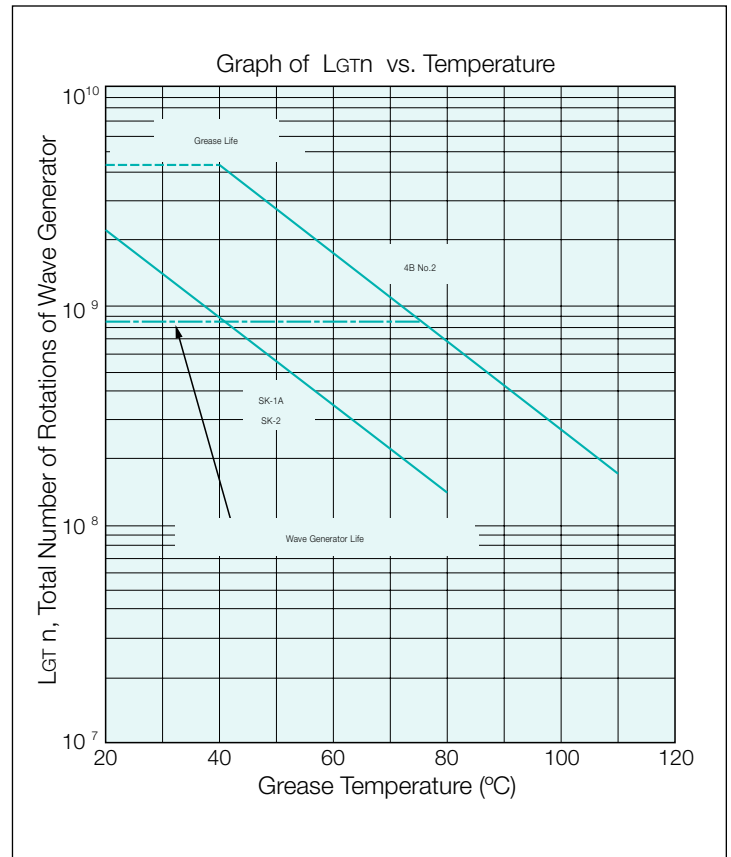

Figure 6

Oil Temperature

In normal use, the oil temperature must not exceed 90°C, Above this temperature oil quickly loses its lubricating capabilities.

Other notes: Avoid mixing different kinds of oil. The gear should be in an individual case when installed.

High Temperature Lubricants

Harmonic Grease 4B No.2

Type of lubricant	Standard temperature range	Possible temperature range
grease	-10°C~+110°C	-50°C~+130°C

High Temperature Lubricant

Type of lubricant	Name of lubricant and manufacturer	Possible temperature range
grease	Mobil Grease 28	-5°C~+160°C
oil	Mobil SHC-626	-5°C~+140°C

Standard temperature is the grease temperature during operation. It is not the ambient temperature.

Oil Change

The first oil change should be performed after 100 hours of operation. The need to perform subsequent oil changes will depend on operating conditions, but should take place at intervals of approximately 1000 running hours.

Low Temperature Lubricant

Type of lubricant	Name of lubricant and manufacturer	Possible temperature range
Grease	Multemp SH-K2 Kyodo Yushi	-30°C~+50°C
	Iso Flex LDS-18 special A NOK klubur	-25°C~+80°C
Oil	SH-200-100CS Tore Silicon	-10°C~+110°C
	Shintesso D-32EP NOK klubur	-25°C~+90°C

The temperature range of the grease can be extended as indicated in the possible temperature range shown. At the low end of this range the efficiency will be low due to an increase in viscosity of the lubricant. At the high end of this range the lubricant life will be low due to an increased deterioration rate from the high temperature.

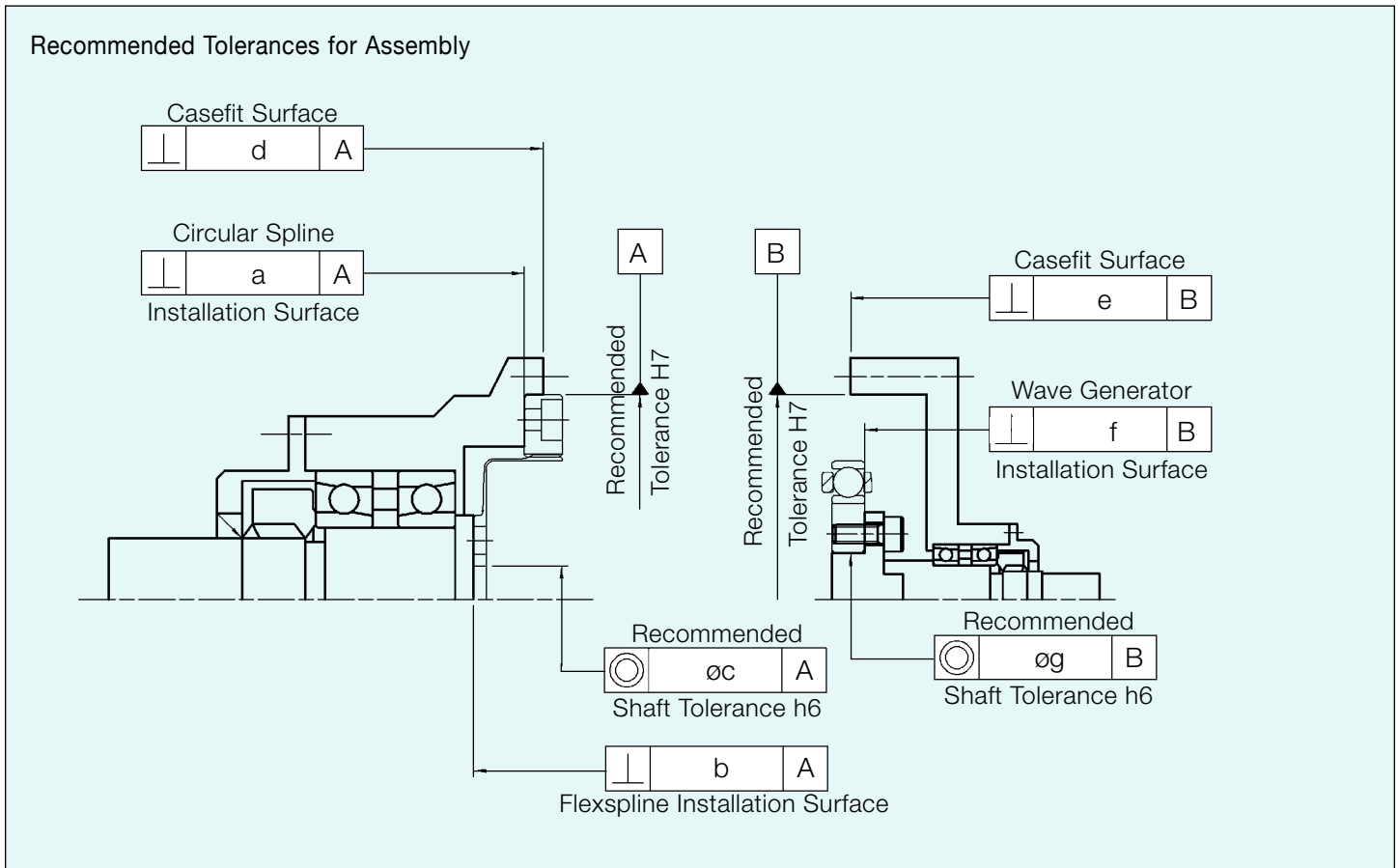

Tolerance for Assembly Table 11

unit:mm

Size	14	17	20	25	32	40	50
a	0.011	0.012	0.013	0.014	0.016	0.016	0.018
b	0.008	0.011	0.014	0.018	0.022	0.025	0.030
ø c	0.015	0.018	0.019	0.022	0.022	0.024	0.030
d	0.011	0.015	0.017	0.024	0.026	0.026	0.028
e	0.011	0.015	0.017	0.024	0.026	0.026	0.028
f	0.008	0.010	0.010	0.012	0.012	0.012	0.015
ø g	0.016	0.018	0.019	0.022	0.022	0.024	0.030

Sealing structure

A seal structure is needed to maintain the high durability of the gear and prevent grease leakage.

Key Points to Verify

- Rotating parts should have an oil seal (with spring), surface should be smooth (no scratches)
- Mating flanges should have an O Ring, seal adhesive
- Screws should have a thread lock
(Loctite 242 recommended) or seal adhesive.

Note: If you use Harmonic Grease 4BNo.2, strict sealing is required.



Toll Free Phone (877) SERV098
Toll Free Fax (877) SERV099
www.electromate.com
sales@electromate.com

Direction for Thrust Force of Wave Generator

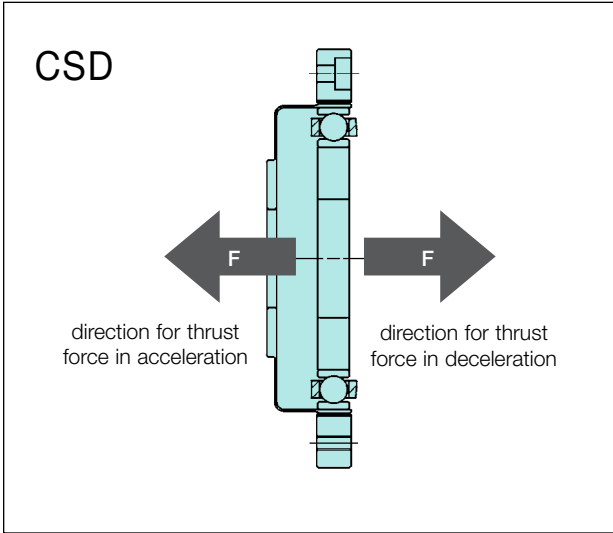

Figure 7

Axial Force of Wave Generator

When a CSD gear is used to accelerate a load, the deflection of the Flexspline leads to an axial force acting on the Wave Generator. This axial force, which acts in the direction of the closed end of the Flexspline, must be supported by the bearings of the input shaft (motor shaft).

When a CSD gear is used to decelerate a load, an axial force acts to push the Wave Generator out of the Flexspline cup. Maximum axial force of the Wave Generator can be calculated by the equation shown below. The axial force may vary depending on its operating condition. The value of axial force tends to be a larger number when using high torque, extreme low speed and constant operation. The force is calculated (approximately) by the equation. In all cases, the Wave Generator must be axially (in both directions), as well as torsionally, fixed to the input shaft.

Note: Please contact us for further information on attaching the Wave Generator to the input (motor) shaft.

Equation [4] for axial force

Gear Ratio	equation
$i=1/50$	$F=2x \frac{T}{D} x 0.07 x \tan 30^\circ + 2\mu PF$
$i=1/100$ and up	$F=2x \frac{T}{D} x 0.07 x \tan 20^\circ + 2\mu PF$

Symbols for equation [4]

F	thrust force	N
D	Gear Size x 0.00254	m
T	output torque	Nm
$2\mu PF$	thrust force by bearing	Nm (see table)

Calculation Example

size	:	32
Ratio	:	$i=1/50$
Output Torque	:	200Nm
$F=2x \frac{200}{(32x0.00254)} x 0.07x \tan 30^\circ + 16$		
$F=215N$		

Table 12

Thrust Force by Bearing		
	Size	$2\mu PF$ (Nm)
CSD	14	2.1
	17	4.1
	20	5.6
	25	9.8
	32	16
	40	24
	50	39

Boss diameter of Flexspline		14	17	20	25	32	40	50
Size		14	17	20	25	32	40	50
ϕJ		23	27.2	32	40	52	64	80

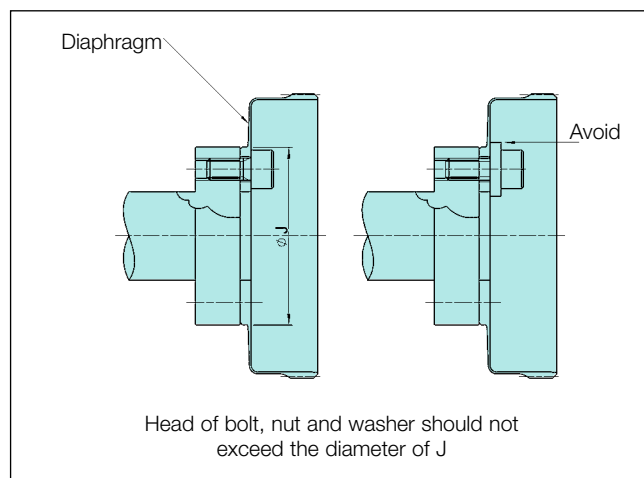
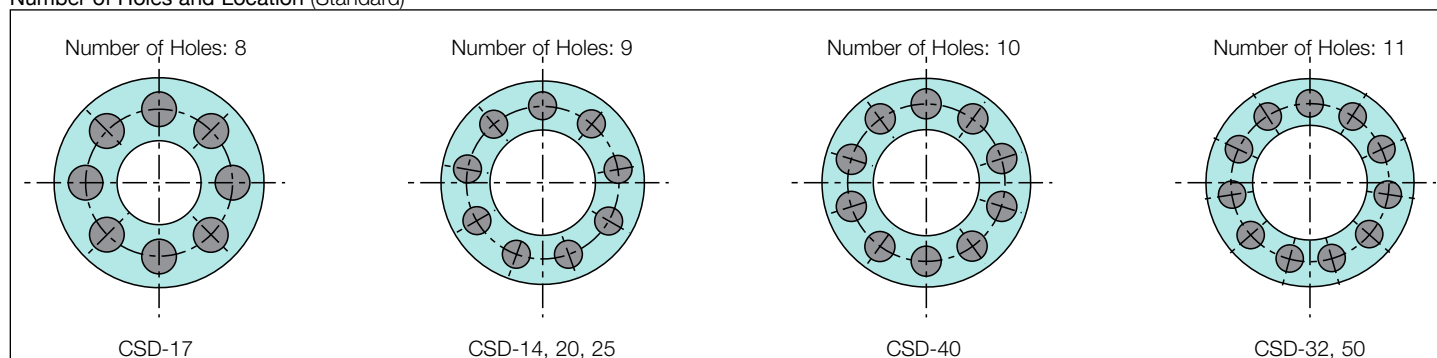
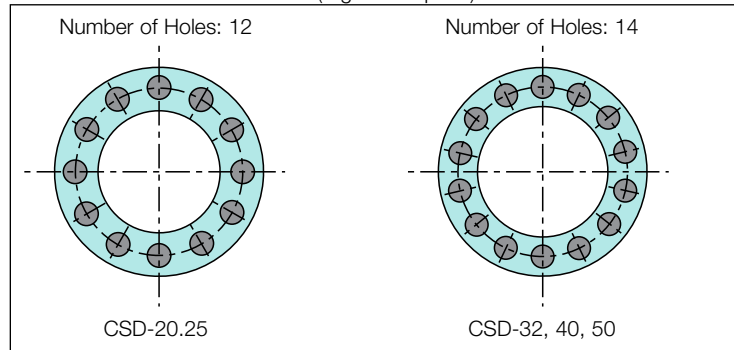

Figure 8

Number of Holes and Location (Standard)



Number of Holes and Location (Big Bore Option)



Sold & Serviced By:



Toll Free Phone (877) SERV098
 Toll Free Fax (877) SERV099
www.electromate.com
sales@electromate.com

	Standard							Big Bore Option					
	14	17	20	25	32	40	50	BB 20	BB 25	BB 32	BB 40	BB 50	
Size	14	17	20	25	32	40	50	BB 20	BB 25	BB 32	BB 40	BB 50	
Number of Bolts	9	8	9	9	11	10	11	12	12	14	14	14	
Size	M3	M4	M4	M5	M6	M8	M10	M3	M4	M5	M6	M8	
Pitch Circle Diameter	mm	17	19.5	24	30	41	48	62	26	32	42	52	65
Clamp Torque	N•m	2.0	4.5	4.5	9.0	15.3	37	74	2	4.5	9.0	15.3	37
Torque transmission	N•m	32	55	76	152	359	694	1577	65	135	331	580	1315

Note:

1. The material of the thread must withstand the clamp torque.
2. Recommended bolt : JIS B 1176 socket head cap screw strength range : JIS B 1051 over 12.9
3. Torque coefficient : K=0.2
4. Clamp coefficient A=1.4
5. Friction coefficient on the surface contacted: 0.15
6. Momentary peak torque is limited in Big Bore since bolt torque transmission of Big Bore is smaller than standard.

Circular Spline Assembly Installation

Circular Spline Bolt Installation Table 15

Size	Standard	14	17	20	25	32	40	50
Number of Bolts		6	8	12	12	12	12	12
Size		M3	M3	M3	M3	M4	M5	M6
Pitch Circle Diameter	mm	44	54	62	75	100	120	150
Clamp Torque	Nm	2.0	2.0	2.0	2.0	4.5	9.0	15.3
Torque transmission	Nm	55	90	155	188	422	810	1434

Note:

1. The material of the thread must withstand the clamp torque.
2. Recommended bolt: JIS B 1176 socket head cap screw strength range : JIS B 1051 over 12.9.
3. Torque coefficient : $K=0.2$
4. Clamp coefficient $A=1.4$
5. Friction coefficient on the surface contacted : 0.15

Component Assembly Procedure

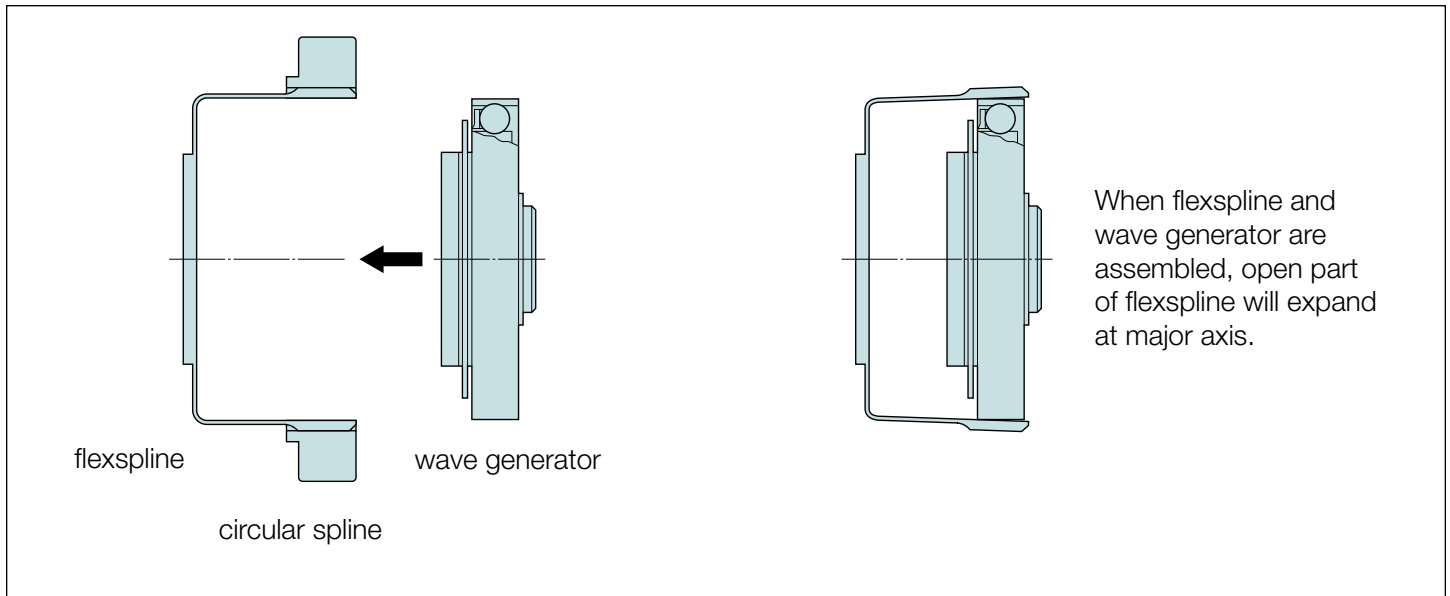

Please see the following notes.

Sold & Serviced By:

 **ELECTROMATE**

Toll Free Phone (877) SERV098

Toll Free Fax (877) SERV099

22 www.electromate.com

sales@electromate.com

CSD assembly procedure

Note for assembly structure for CSD

Wave Generator

1. Avoid overloading the Wave Generator bearing during installation, rotate the Wave Generator as you easily install.
2. Since the Wave Generator of the CSD does not have an Oldham coupling, make sure that the position is within the recommended tolerance shown on page18.
3. Installation bolts on Wave Generator and installation bolt on Flexspline should not interfere each other.

Circular Spline

1. Be sure flatness and skewness are minimized.
2. Make sure there are no burrs or foreign substances.
3. Make sure there is enough room to have the minimum clearance in the housing.
4. Make sure that the Circular Spline can rotate in the housing when it is installed
5. When a bolt is inserted into a bolt hole, make sure that the bolt hole is located properly.
7. Bolts should not be tightened at the same time. Apply half of the recommended torque to tighten bolts, and then tighten bolts at the recommended torque. The order of tightening bolts should be done diagonally.

Avoid using pins to secure the Circular Spline if possible.

Flexspline

1. Be sure flatness and skewness are minimized.
2. Make sure there are no burrs or foreign substances.
3. Make sure there is enough room to have the minimum clearance in the housing.
4. When a bolt is inserted into a bolt hole, make sure that the bolt hole is located properly.
5. Bolts should not be tightened at the same time. Apply half of the recommended torque to tighten bolts, and then tighten bolts at recommended torque. The order of tightening bolts should be done diagonally.

Make sure that Circular Spline and Flexspline mesh properly.

Do not damage the Flexspline during assembly.

Note to prevent corrosion

The standard CSD has not been treated for preventing corrosion. If needed, apply rust prevention on metal surfaces. As a special order, Harmonic Drive LLC can provide stainless steel components or surface treatments.

Sold & Serviced By:



Toll Free Phone (877) SERV098
Toll Free Fax (877) SERV099
www.electromate.com
sales@electromate.com

SHD External Dimensions

SHD SERIES

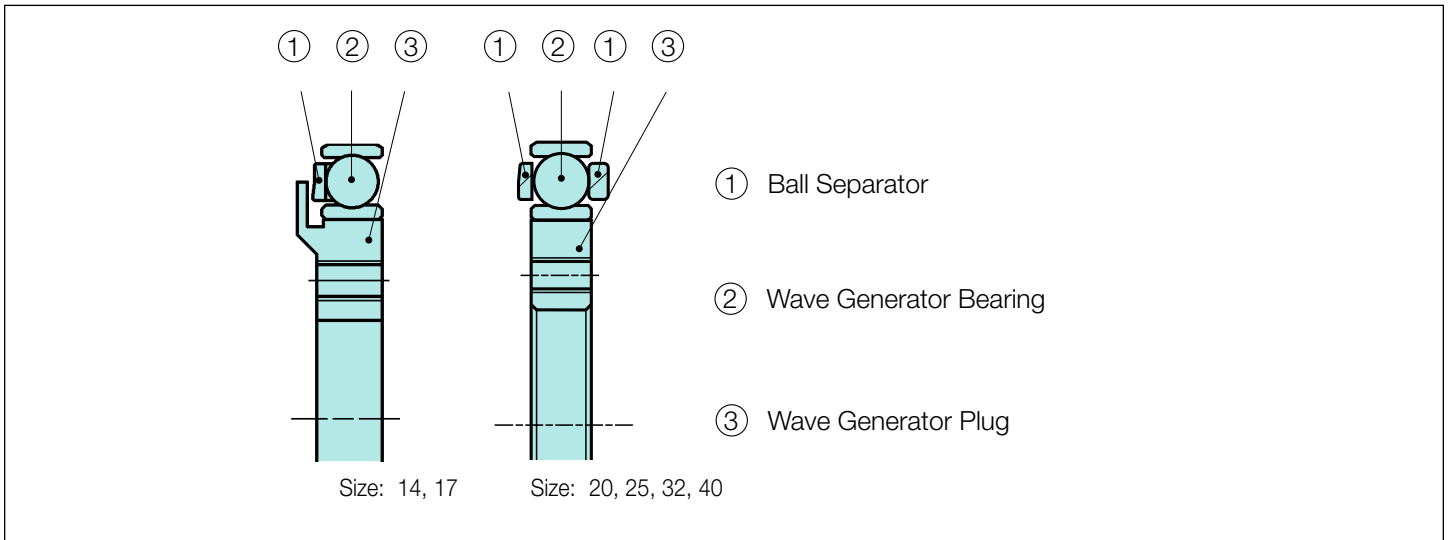
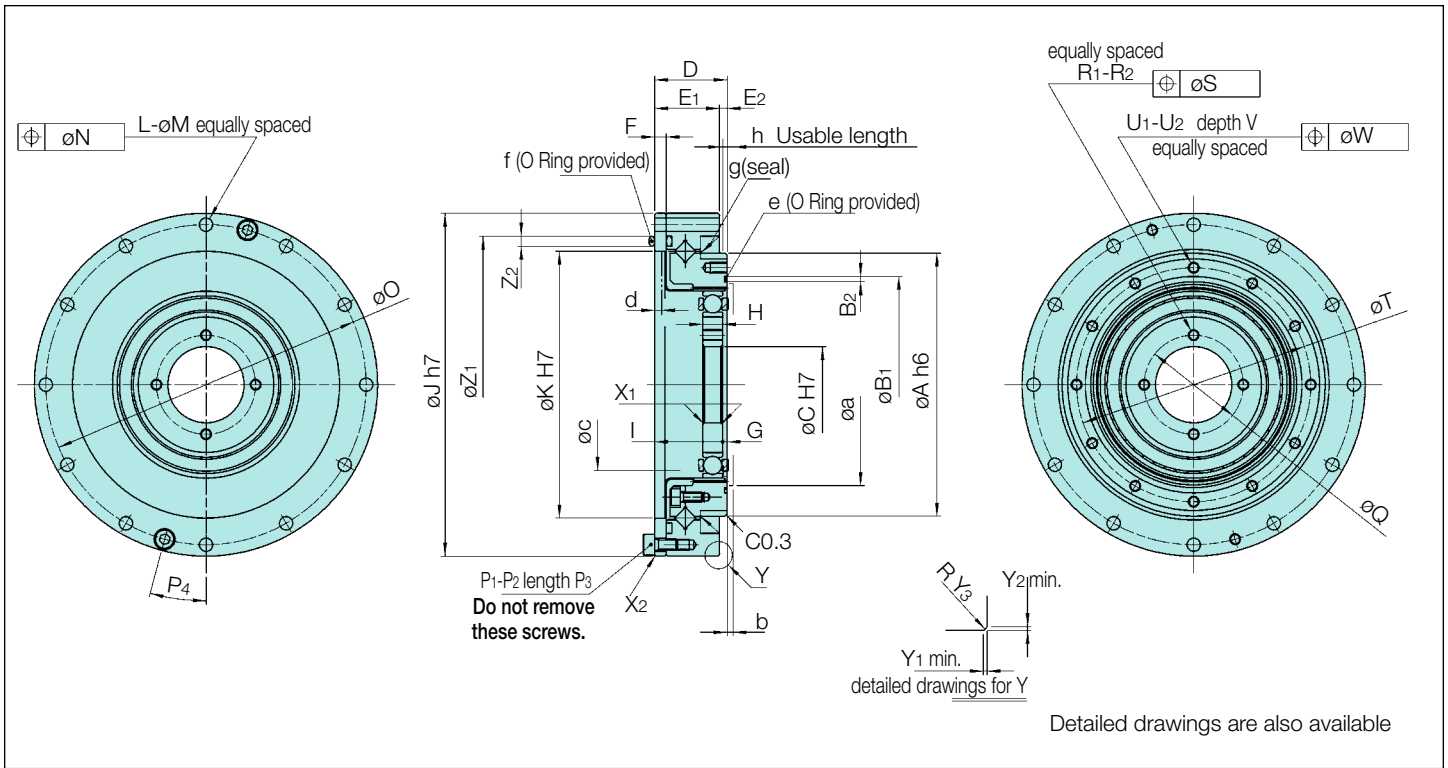

Size: 14, 17

Size: 20, 25, 32, 40

SHD Dimensions Table 16

(mm)

	14	17	20	25	32	40
$\varnothing A_{h6}$	49 ⁰ _{-0.016}	59 ⁰ _{-0.019}	69 ⁰ _{-0.019}	84 ⁰ _{-0.022}	110 ⁰ _{-0.022}	132 ⁰ _{-0.025}
$\varnothing B_1$	39.1 ^{+0.1} ₀	48 ^{+0.1} ₀	56.8 ^{+0.1} ₀	70.5 ^{+0.1} ₀	92 ^{+0.1} ₀	112.4 ^{+0.1} ₀
B_2	0.8 ^{+0.15} ₀	1.1 ^{+0.25} ₀	1.4 ^{+0.25} ₀	1.7 ^{+0.25} ₀	2 ^{+0.25} ₀	2.2 ^{+0.25} ₀
$\varnothing CH7$	11 ^{+0.018} ₀	15 ^{+0.018} ₀	20 ^{+0.021} ₀	24 ^{+0.021} ₀	32 ^{+0.025} ₀	40 ^{+0.025} ₀
D	17.5 ^{±0.1}	18.5 ^{±0.1}	19 ^{±0.1}	22 ^{±0.1}	27.9 ^{±0.1}	33 ^{±0.1}
E_1	15.5	16.5	17	20	23.6	28
E_2	2	2	2	2	4.3	5
F	2.4	3	3	3.3	3.6	4
G	1.8	1.6	1.2	0.4	0.6	0.8
H	4 ⁰ _{-0.1}	5 ⁰ _{-0.1}	5.2 ⁰ _{-0.1}	6.35 ⁰ _{-0.1}	8.6 ⁰ _{-0.1}	10.3 ⁰ _{-0.1}
I	15.7 ⁰ _{-0.2}	16.9 ⁰ _{-0.2}	17.8 ⁰ _{-0.2}	21.6 ⁰ _{-0.2}	27.3 ⁰ _{-0.2}	32.2 ⁰ _{-0.2}
$\varnothing J_{h7}$	70 ⁰ _{-0.030}	80 ⁰ _{-0.030}	90 ⁰ _{-0.035}	110 ⁰ _{-0.035}	142 ⁰ _{-0.040}	170 ⁰ _{-0.040}
$\varnothing KH7$	50 ^{+0.025} ₀	61 ^{+0.030} ₀	71 ^{+0.030} ₀	88 ^{+0.035} ₀	114 ^{+0.035} ₀	140 ^{+0.040} ₀
L	8	12	12	12	12	12
$\varnothing M$	3.5	3.5	3.5	4.5	5.5	6.6
$\varnothing N$	0.25	0.25	0.25	0.25	0.25	0.3
$\varnothing O$	64	74	84	102	132	158
P_1	2	2	2	4	4	4
P_2	M3	M3	M3	M3	M4	M4
P_3	6	6	6	8	10	10
P_4	22.5°	15°	15°	15°	15°	15°
$\varnothing Q$	17	21	26	30	40	50
R_1	4	4	4	4	4	4
R_2	M3	M3	M3	M3	M4	M5
$\varnothing S$	0.25	0.25	0.25	0.25	0.25	0.25
$\varnothing T$	43	52	61.4	76	99	120
U_1	8	12	12	12	12	12
U_2	M3	M3	M3	M4	M5	M6
V	4.5	4.5	4.5	6	8	9
$\varnothing W$	0.25	0.25	0.25	0.25	0.25	0.3
X_1	C0.4	C0.4	C0.5	C0.5	C0.5	C0.5
X_2	C0.4	C0.4	C0.5	C0.5	C0.5	C0.5
Y_1	0.4	0.4	0.5	0.5	0.5	0.5
Y Y_2	0.4	0.4	0.5	0.5	0.5	0.5
RY_3	1.2	1.2	1.5	1.5	1.5	1.5
Z_1	57 ^{+0.1} ₀	68.1 ^{+0.1} ₀	78 ^{+0.1} ₀	94.8 ^{+0.1} ₀	123 ^{+0.1} ₀	148 ^{+0.1} ₀
Z_2	2 ^{+0.25} ₀	2 ^{+0.25} ₀	2.7 ^{+0.25} ₀	2.4 ^{+0.25} ₀	2.7 ^{+0.25} ₀	2.7 ^{+0.25} ₀
$\varnothing a$	36.5	45	53	66	86	106
b	1	1	1.5	1.5	2	2.5
$\varnothing c$	31	38	45	56	73	90
d	1.4	1.8	1.7	1.8	1.8	1.8
e	d37.1d0.6	d45.4d0.8	d53.28d0.99	d66.5d1.3	d87.5d1.5	d107.5d1.6
f	d54.38d1.19	d64.0d1.5	d72.0d2.0	d88.62d1.78	d117.0d2.0	d142d2.0
g	D49585	D59685	D69785	D84945	D1101226	D1321467
h	1.5	1.5	1.5	1.5	3.3	4
Weight (kg)	0.33	0.42	0.52	0.91	1.87	3.09

- The following parameters can be modified to accommodate customer specific requirements.

Wave generator : $\varnothing C$

Flexspline : $\varnothing O$

Circular Spline : X_1, X_2

- Minimum housing clearance parameters $\varnothing a, b, \varnothing c, d$ must be maintained to prevent damage to the gear during operation.

Sold & Serviced By:



Toll Free Phone (877) SERV098

Toll Free Fax (877) SERV099

www.electromate.com

sales@electromate.com

Specifications for Cross Roller Bearing

Specification for Cross Roller Bearing

Housed units incorporate a precise cross roller bearing to directly support a load. The inner race of the bearing forms the output flange.

Please calculate maximum load moment, life of cross roller bearing, and static safety factor to fully maximize the performance of the housed unit (gearhead).

Calculation Procedure

1. Maximum Load Moment (Mmax)

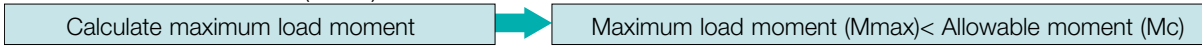

2. Output Bearing Life

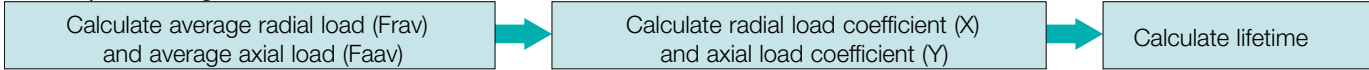

3. Static Safety Factor

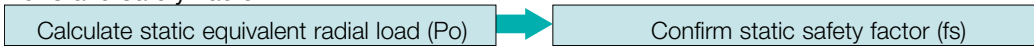

Specification for cross roller bearing

Specification for cross roller bearing is shown on figure.

Table 17

Size	Pitch Circle dp m	Offset R mm	Basic Dynamic Rated Load C		Basic Static Rated Load Co		Allowable Moment Load Mc		Moment Rigidity Km	
			X10 ³ N	lb	X10 ³ N	lb	Nm	in-lb	x10 ⁴ Nm/rad	in-lb/ arc-min
14	0.0503	11.1	29	652	43	967	37	327	7.08	182
17	0.061	11.5	52	1169	81	1821	62	548	12.7	326
20	0.070	11.0	73	1641	110	2473	93	823	21	540
25	0.086	12.1	109	2451	179	4024	129	1141	31	796
32	0.112	17.3	191	4294	327	7352	290	2566	82.1	2110
40	0.133	19.5	216	4856	408	9173	424	3752	145	3726

Basic dynamic rated load is a constant radial load where the basic dynamic rated life of CRB is 1×10^6 rotations.

Basic static rated load is a static load where the value of moment rigidity is the average value.

For the following size and gear ratio combinations, the life of the cross roller bearing operating at the allowable moment load is less than the life of the wave generator bearing ($L_{10} = 7000$ hr) operating at 2000rpm and rated torque.

Table 18

Size	Gear Ratio	
14	50	100
17	50	
20	50	

Sold & Serviced By:

 **ELECTROMATE**

Toll Free Phone (877) SERV098

Toll Free Fax (877) SERV099

26 www.electromate.com

sales@electromate.com

How to Calculate the Maximum Load Moment

How to calculate the Maximum load moment is shown below. Please be sure that M_c is equal or greater than M_{max} .

$$M_{max} = F_{rmax} \cdot (L_r + R) + F_{amax} \cdot L_a$$

How to Calculate an Average Load

To calculate average radial load, average axial load or average output speed, follow steps below.

When the radial load and axial load vary, the life of cross roller bearing can be determined by converting to an average load. (see figure 10)

equation (5) Calculate Average Radial Load

$$F_{rav} = \sqrt[10/3]{\frac{n_1 t_1 |F_{r1}|^{10/3} + n_2 t_2 |F_{r2}|^{10/3} \dots + n_n t_n |F_{rn}|^{10/3}}{n_1 t_1 + n_2 t_2 \dots + n_n t_n}}$$

F_{r1} is radial load in t_1 , F_{r3} is radial load in t_3 .

equation (6) Calculate Average Axial Load (F_{aav})

$$F_{aav} = \sqrt[10/3]{\frac{n_1 t_1 |F_{a1}|^{10/3} + n_2 t_2 |F_{a2}|^{10/3} \dots + n_n t_n |F_{an}|^{10/3}}{n_1 t_1 + n_2 t_2 \dots + n_n t_n}}$$

F_{a1} is axial load in t_1 , F_{a3} is axial load in t_3 .

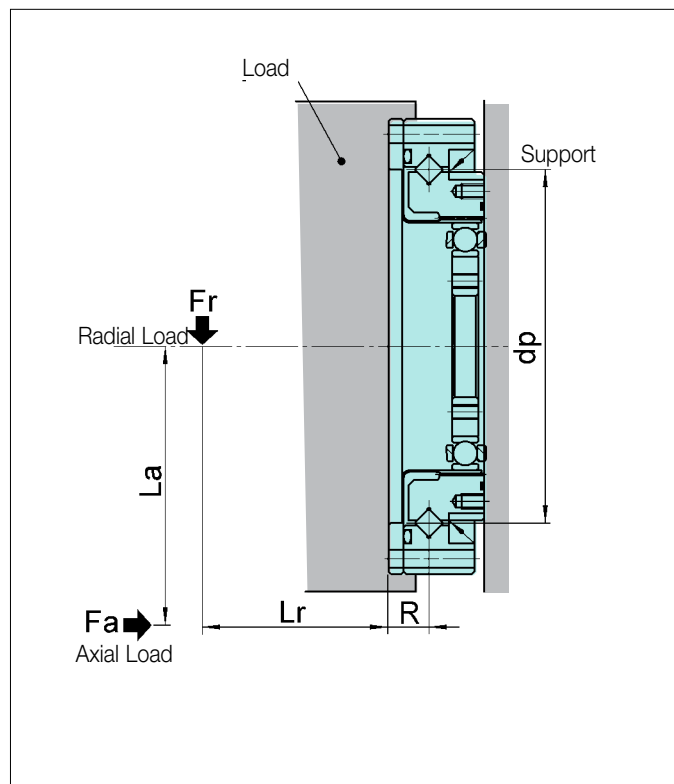

Figure 9

equation (7) Calculate Average Output Speed

$$N_{av} = \frac{n_1 t_1 + n_2 t_2 \dots + n_n t_n}{t_1 t_2 \dots + t_n}$$

Calculate radial load coefficient (X) axial load (Y)

$\frac{F_{aav}}{F_{rav} + 2(F_{rav}(L_r + R) + F_{aav} \cdot L_a) / dp}$	≤ 1.5	1	0.45
$\frac{F_{aav}}{F_{rav} + 2(F_{rav}(L_r + R) + F_{aav} \cdot L_a) / dp}$	> 1.5	0.67	0.67

F_{rmax}	Max. radial load	N	Figure 10
F_{amax}	Max. axial load	N	Figure 10
L_r, L_a	Moment arm	m	Figure 9
R	amount of offset	m	Table 17
dp	pitch circle	m	Table 17

Figure 10

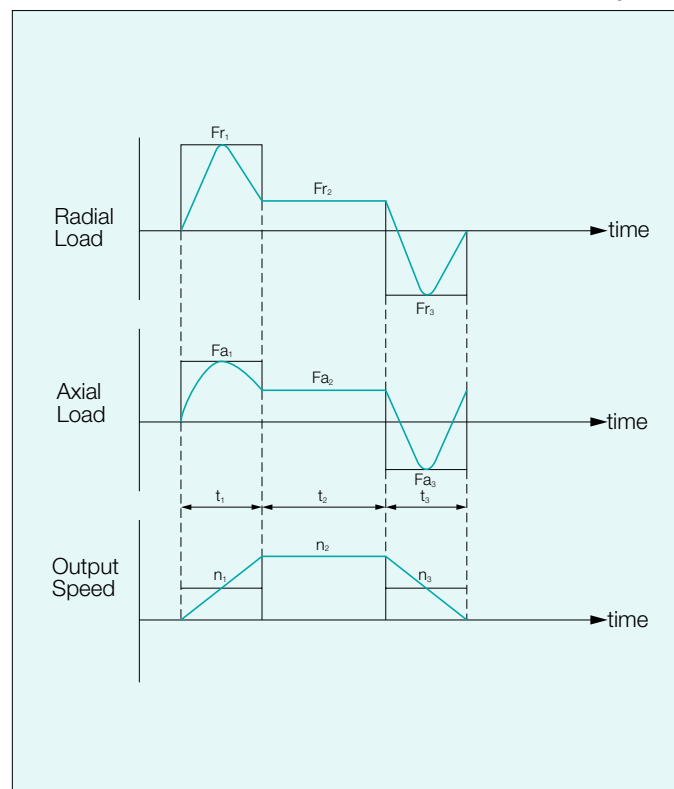

How to Calculate Life of the Output Bearing

The life of a cross roller bearing can be calculated by equation (8).

equation (8)

$$L_{10} = \frac{10^6}{60 \times \text{Nav}} \times \left(\frac{C}{f_w \cdot P_c} \right)^{10/3}$$

List 1

L_{10}	Life	Hour	equation 8
Nav	Average Output Speed	rpm	equation 7
C	Basic Dynamic Rated Load	N	table 17
P_c	Dynamic Equivalent	N	equation 9
f_w	Load Coefficient	———	list 2

List 2

Load Coefficient,	f_w
Steady operation without impact and vibration	1~1.2
Normal operation	1.2~1.5
Operation with impact and vibration	1.5~3

Dynamic Equivalent Radial Load

equation (9)

$$P_c = X \cdot \left(\frac{F_{rav} + 2(F_{rav}(L_r + R) + F_{aav} \cdot L_a)}{d_p} \right) + Y \cdot F_{aav}$$

Symbol of equation (8)

F_{rav}	Average radial load	N	equation 5
F_{aav}	Average axial load	N	equation 6
d_p	Pitch diameter	m	table 17
X	Radial load coefficient	———	list page 26
Y	Axial load coefficient	———	list page 26
L_r, L_a	Moment Arm	m	figure 9
R	Offset	m	figure 9 and table 17

How to Calculate Static Safety Coefficient

Basic static rated load is an allowable limit for static load, but its limit is determined by usage. In this case, static safety coefficient of the cross roller bearing can be calculated by equation 10.

Reference values under general conditions are shown on list 3.

Static equivalent radial load can be calculated by equation (12)

equation (10)

$$f_s = \frac{C_0}{P_0}$$

equation (12)

$$P_0 = F_{rmax} + \frac{2M_{max}}{d} + 0.44 \cdot F_{amax}$$

Symbols for equation (9)

C_0	Basic static rated load	N	table 17
P_0	Static equivalent radial load	N	refer to equation 12

list 3

Load Conditions	Lower Limit Value for f_s
Impact loads	$1-1.5 \geq 2$
Normal loads	≥ 1.5
High accuracy required	≥ 3

How to Calculate Life for Oscillating Motion

The Life of a cross roller bearing in a oscillating operation can be calculated by equation 11

equation (11)

$$L_{oc} = \frac{10^6}{60 \times n1} \times \frac{90}{\emptyset} \times \left(\frac{C}{f_w \cdot P_c} \right)^{10/3}$$

Symbol of equation (11)

List 4

L_{oc}	Rated life for oscillating motion	Hour	equation 11
$n1$	Round trip oscillation each minute	rpm	———
C	Basic dynamic rated load	N	table 17
P_c	Dynamic equivalent radial load	N	equation 9
f_w	Load Coefficient	———	list 2
\emptyset	Angle of oscillation/2	degrees	figure 11

figure 11

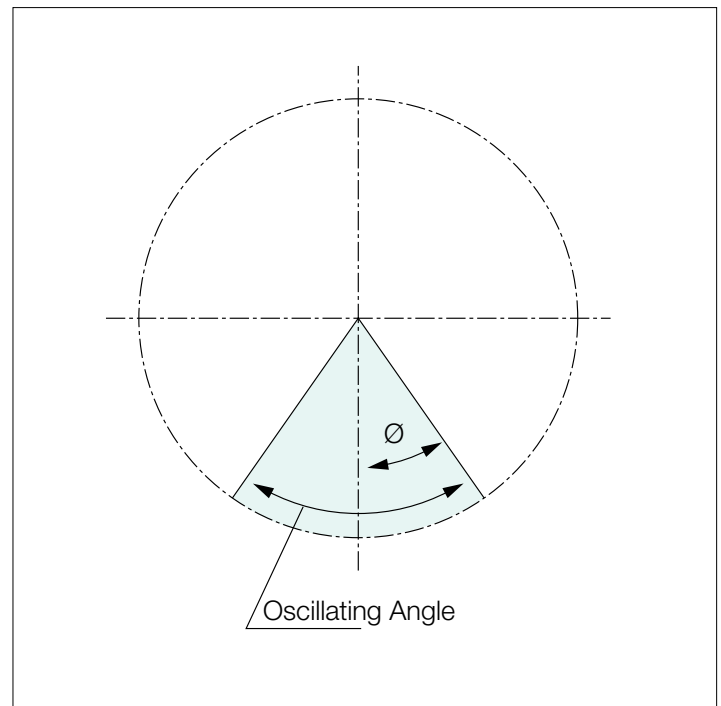

A small angle of oscillation (less than 5 degrees) may cause fretting corrosion to occur since lubrication may not circulate properly.

Lubricant

Grease lubricant is the standard for the SHD unit. The temperature range is shown below. (Exceptions are shown on page 17.)

Lubricant			Lubricant		
Grease	Harmonic Grease	SK-1A	Grease	SK-1A	0°C~+ 40°C
Grease	Harmonic Grease	SK-2	Grease	SK-2	0°C~+ 40°C
Grease	Harmonic Grease	4B-No.2	Grease	4B-No.2	-10°C~+ 70°C

Harmonic Grease SK-1A

This grease is developed for a Harmonic Drive™ gear and features good durability and efficiency.

Harmonic Grease SK-2

This grease is developed for a small size Harmonic Drive™ gear and features smooth rotation of the Wave Generator since high pressure additive is liquefied.

Harmonic Grease 4B No.2

This grease is developed for Harmonic Drive™ gearing and features long life and a wide range of temperature.

Note 1

Grease lubrication must have proper sealing, this is essential for 4BNo. 2.

Rotating part: Oil seal with spring is needed.

Mating part: O ring or seal adhesive is needed.

Note 2

The grease has the highest deterioration rate where the grease is subjected to the greatest shear (near wave generator). Its viscosity is between JIS No.0 and No. 00 depending on the operation.

Recommended Grease

Size	14	17	20	25	32	40
SK-1A	—	—	O	O	O	O
SK-2	O	O	Δ	Δ	Δ	Δ
4BNo.2	•	•	•	•	•	•

•: recommended grease for long life and high load O: Standard Δ: Semistandard

Characteristics of Grease

Grease	SK-1A	SK-2	4BNo.2
Durability	O	O	•
Fretting Resistance	O	O	•
Low Temp	Δ	Δ	•
Grease Leakage	•	•	Δ

•: Excellent O: Good Δ: Exercise Caution

Recommended Grease

Grease	SK-1A	SK-2	4B No.2
Base Oil	Refined mineral hydrocarbon base oil	Refined mineral hydrocarbon base oil	Hydrocarbon type synthetic oil and polymer
Thickening Agent	Lithium soap thickener	Lithium soap thickener	Urea
Additive	Organic molybdenum, etc.	Organic molybdenum, etc.	Organic molybdenum, etc.s
NLGI Consistency No.	No.2	No.2	No.1.5
Viscosity (25C), cSt	265 to 295	265 to 295	290 to 320
Melting Point	197°C	198°C	247°C
Color	Yellow	Green	Light Yellow
Life	5 Years in Airtight Container		

Note: Proper lubrication of the gearing is essential for high performance and reliability.

Recommended Dimensions for Inner Case

These dimensions must be maintained to prevent damage to the gear and to maintain a proper grease cavity.

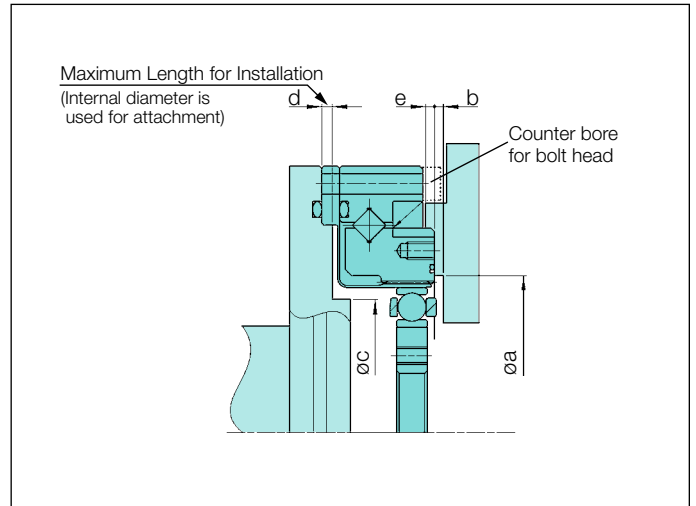

Figure 12

Recommended Dimensions for Inner Case Table 19

Unit: mm

Size	14	17	20	25	32	40
ø a	36.5	45	53	66	86	106
b	1(3)	1(3)	1.5(4.5)	1.5(4.5)	2(6)	2.5(7.5)
ø c	31	38	45	56	73	90
d	1.4	1.8	1.7	1.8	1.8	1.8
e	1.5	1.5	1.5	1.5	3.3	4

Note: Values in parenthesis show the value when the Wave Generator is pointing up.

Grease Usage Table 20

Unit: g

Size	14	17	20	25	32	40
grease amount	5	9	13	24	51	99

The Flexspline teeth, Circular spline teeth and Cross roller bearing are grease lubricated at the Factory.

Figure 13

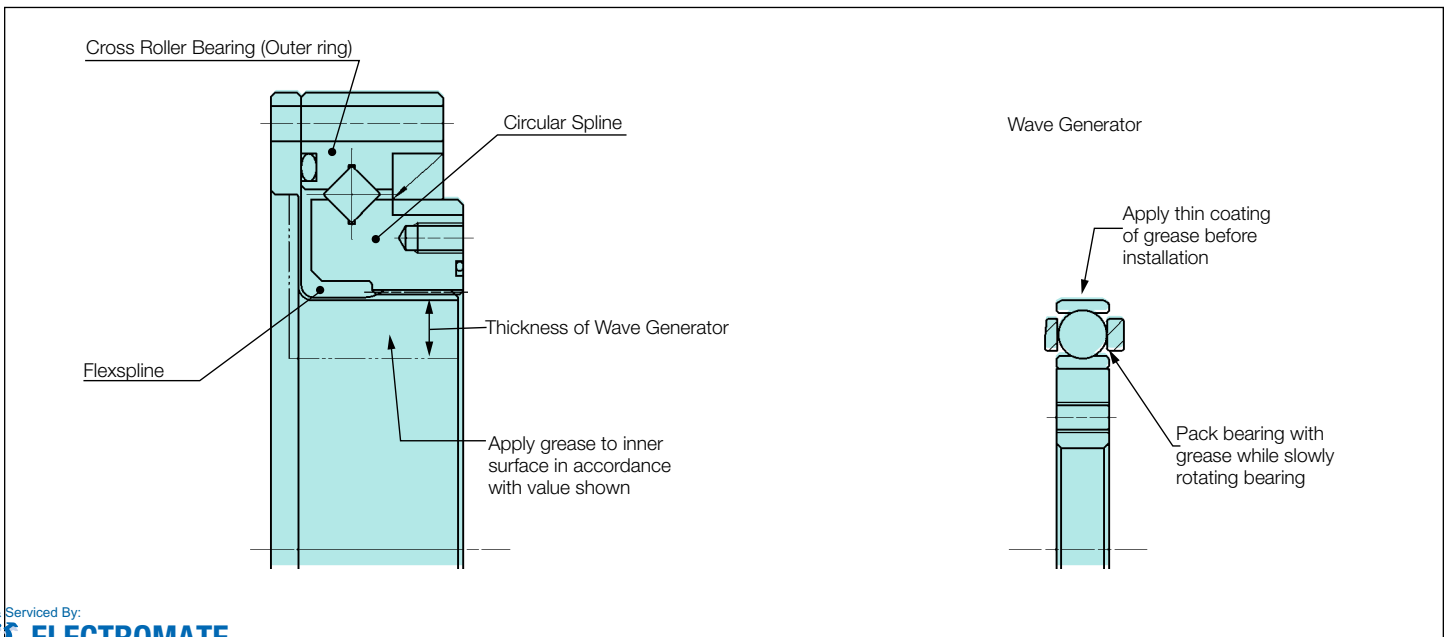

Grease Change

The wear characteristics of the gear are strongly influenced by the condition of the grease lubrication. The condition of the grease is affected by the ambient temperature. The graph shows the maximum number of input rotations for various temperatures. This graph applies to applications where the average load torque does not exceed the rated torque.

In cases where the average load torque exceeds, calculate the grease change interval using the equation shown below.

Equation where average load torque exceeds rated torque
[Equation 13]

$$L_{GT} = L_{GTn} \times \left(\frac{T_r}{T_{av}}\right)^3$$

Symbol of Equation [13]	
L_{GT}	Grease change (Torque is over rated torque), input rotations
L_{GTn}	Grease change (Torque is below rated torque), input rotations (From Graph)
T_r	Rated Torque
T_{av}	Average load torque on output

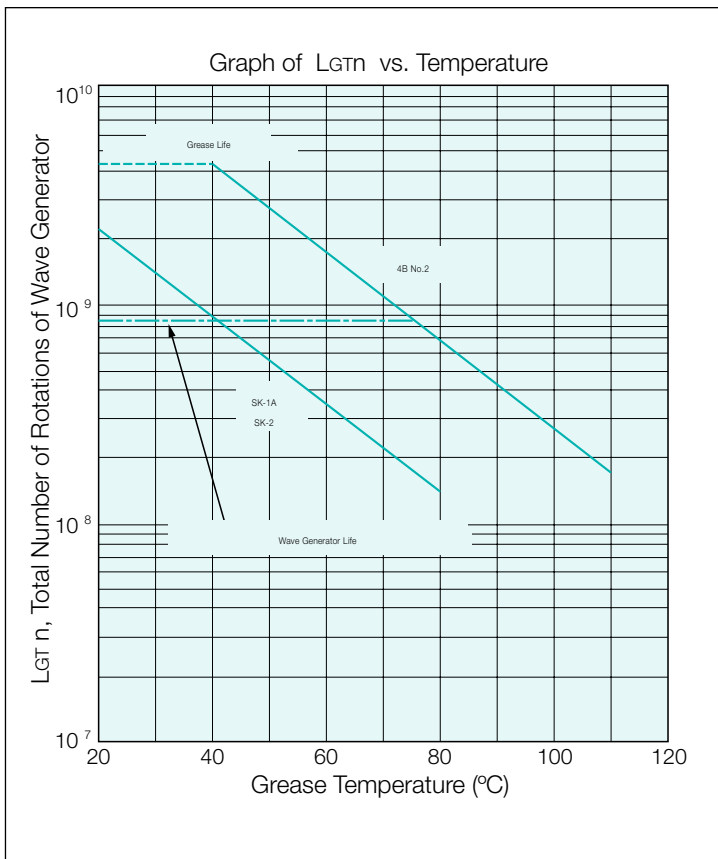
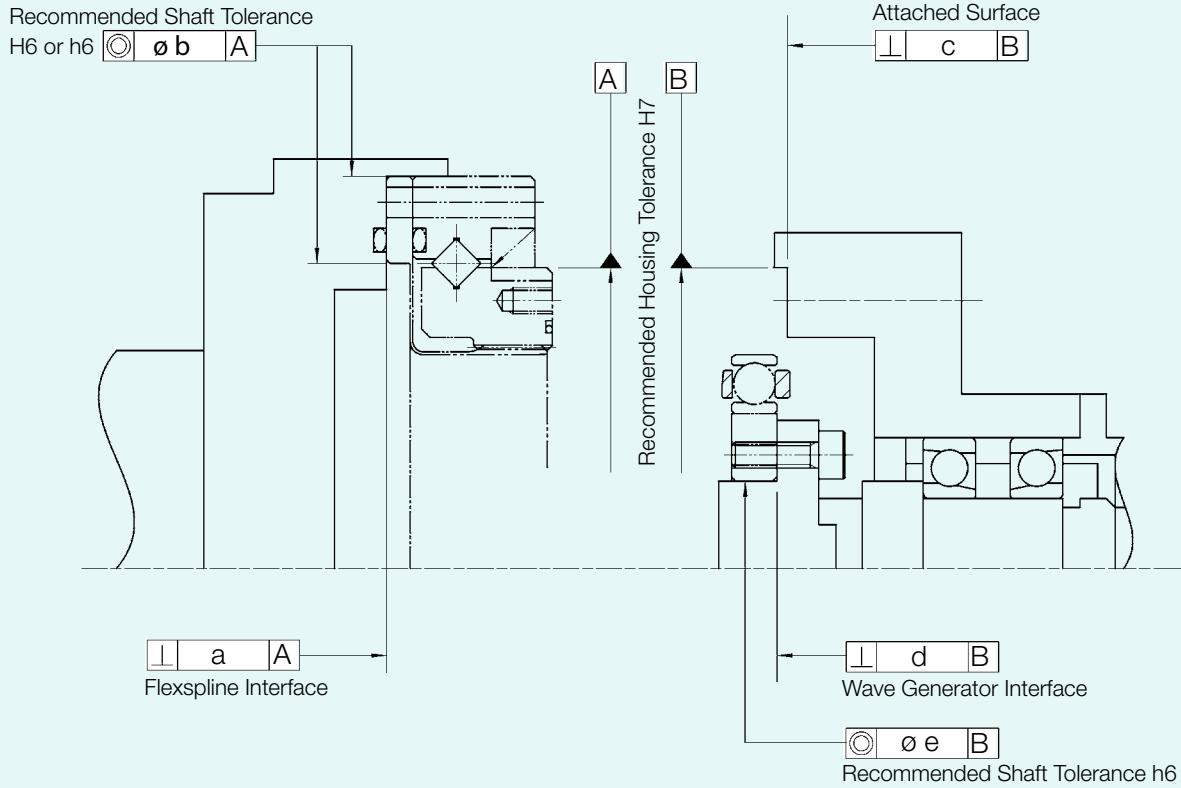

Figure 14

Recommended Tolerances for Assembly

For peak performance of the SHD it is essential that the following tolerances be observed when assembly is complete.

Recommended tolerances for assembly



Tolerances for Assembly Table 21

Size	14	17	20	25	32	40	Unit:mm
a	0.016	0.021	0.027	0.035	0.042	0.048	
$\varnothing b$	0.015	0.018	0.019	0.022	0.022	0.024	
c	0.011	0.012	0.013	0.014	0.016	0.016	
d	0.008	0.010	0.012	0.012	0.012	0.012	
$\varnothing e$	0.016	0.018	0.019	0.022	0.022	0.024	

Sealing structure

A seal structure is needed to maintain the high durability of the gear and prevent grease leakage.

Key Points to Verify

- Rotating parts should have an oil seal (with spring), surface should be smooth (no scratches)
- Mating flanges should have an O Ring, seal adhesive
- Screws should have a thread lock
(Loctite 242 recommended) or seal adhesive.

Note: If you use Harmonic grease 4BNo.2, strict sealing is required.

Direction for Thrust Force of Wave Generator

Axial Force of Wave Generator

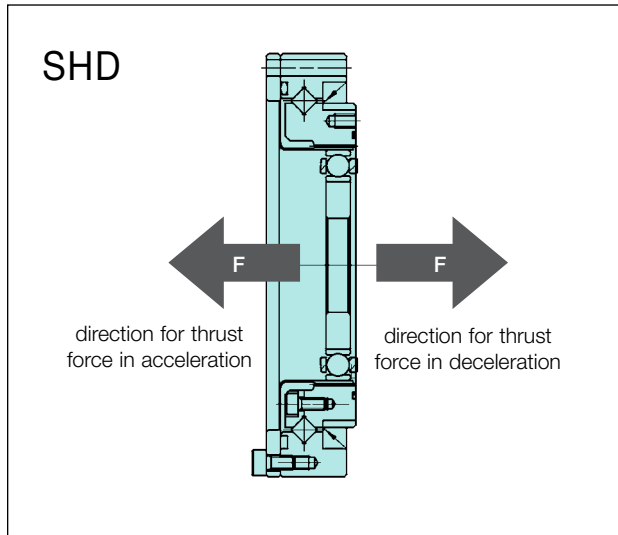

Figure 15

When a SHD gear is used to accelerate a load, the deflection of the Flexspline leads to an axial force acting on the Wave Generator. This axial force, which acts in the direction of the back end of the Flexspline, (toward the left in fig.15) must be supported by the bearings of the input shaft (motor shaft).

When a SHD gear is used to decelerate a load, an axial force acts to push the Wave Generator out of the Flexspline (toward the right in fig.15). Maximum axial force of the Wave Generator can be calculated by the equation shown below. The axial force may vary depending on its operating condition. The value of axial force tends to be a larger number when using high torque, extreme low speed and constant operation. The force is calculated (approximately) by the equation. In all cases, the Wave Generator must be axially (in both directions), as well as torsionally, fixed to the input shaft.

(note) Please contact us for detailed information on attaching the Wave Generator to the input (motor) shaft.

Equation [14] for axial force

Gear Ratio	equation
$i=1/50$	$F=2x \frac{T}{D} x 0.07 x \tan 30^\circ + 2\mu PF$
$i=1/100$ and up	$F=2x \frac{T}{D} x 0.07 x \tan 20^\circ + 2\mu PF$

Symbols for equation [4]

F	thrust force	N
D	Gear Size x 0.00254	m
T	output torque	Nm
$2\mu PF$	thrust force by bearing	Nm (see table)

Calculation Example

size	:	32
Ratio	:	$i=1/50$
Output Torque	:	200Nm
$F=2x \frac{200}{(32x0.00254)} x 0.07x \tan 30^\circ + 16$		
$F=215N$		

Thrust Force by Bearing SHD

Model Name	Model Number	$2\mu PF$ (N)
SHD	14	1.2
	17	3.3
	20	5.6
	25	9.3
	32	16
	40	24

Assembly Notes

Output for SHD varies depending on which component is fixed. Gear ratio and rotational direction also vary. see page 5

Fixed	Output	Ratio and Rotation
Flexspline	Circular Spline	② on page 5
Circular Spline	Flexspline	① on page 5

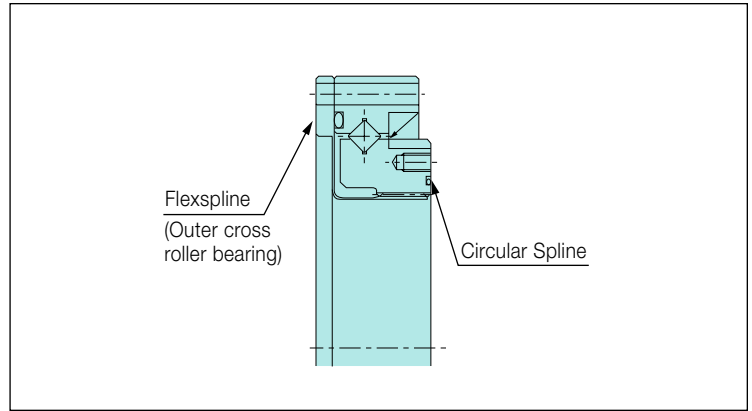

Figure 16

Installation and Torque Transmission for Flexspline Bolts

Table 23

Size	Standard	14	17	20	25	32	40
Number of Bolts		8	12	12	12	12	12
Size		M3	M3	M3	M4	M5	M6
Pitch Circle Diameter	mm	64	74	84	102	132	158
Clamp Torque	Nm	2.0	2.0	2.0	4.5	9.0	15.3
Torque transmission	Nm	108	186	210	431	892	1509

Note:

1. The material of the thread must withstand the clamp torque.
2. Recommended bolt : JIS B 1176 socket head cap screw strength range : JIS B 1051 over 12.9
3. Torque coefficient : K=0.2
4. Clamp coefficient A=1.4
5. Friction coefficient on the surface contacted: 0.15

Installation and Torque Transmission for Circular Spline Bolts

Table 24

Size	Standard	14	17	20	25	32	40
Number of Bolts		6	12	12	12	12	12
Size		M3	M3	M3	M4	M5	M6
Pitch Circle Diameter	mm	43	52	61.4	76	99	120
Clamp Torque	Nm	2.0	2.0	2.0	4.5	9.0	15.3
Torque transmission	Nm	72	130	154	321	668	1148

Note:

1. The material of the thread must withstand the clamp torque.
2. Recommended bolt : JIS B 1176 socket head cap screw strength range : JIS B 1051 over 12.9
3. Torque coefficient : K=0.2
4. Clamp coefficient A=1.4
5. Friction coefficient on the surface contacted: 0.15

Manufacturing for Mating Part and Housing

When the housing interferes with corner "A" shown in fig. 17, an undercut in the housing is recommended as shown in fig. 18.

Figure 17

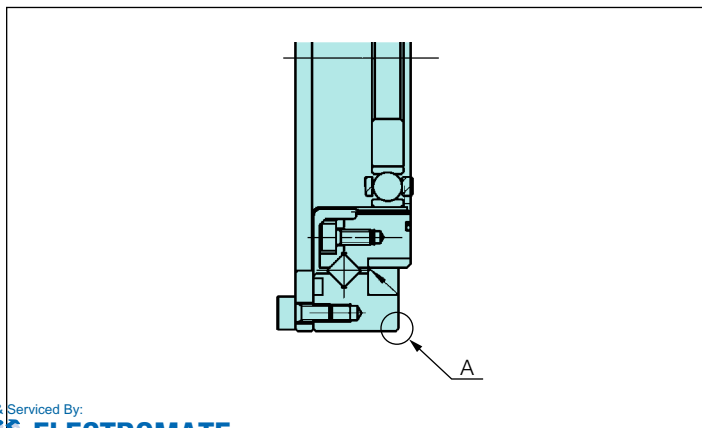
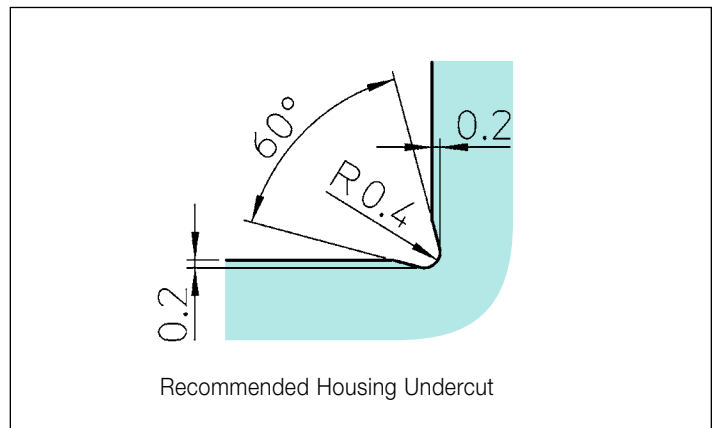

Figure 18



Assembly Order for Basic Three Elements

The recommended sequence of assembly is illustrated below.

Only after the Circular Spline and Flexspline are assembled in equipment is the Wave Generator assembled. If assembly is performed using a different method, Dedoidal assembly or teeth breakage may occur. It is essential that teeth of the Flexspline and Circular Spline mesh symmetrically for proper function. An eccentric tooth mesh (Dedoidal), will result in noise and may lead to early failure of the gear.

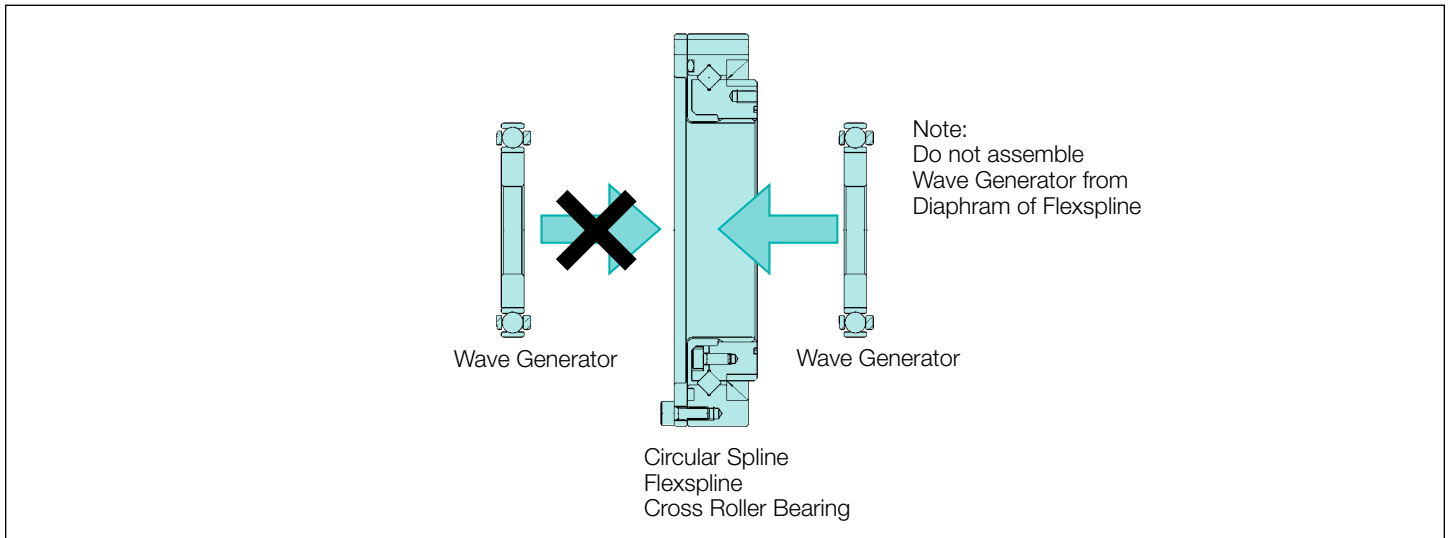

Figure 19

SHD assembly procedure

Note for assembly structure for SHD

Wave Generator

1. Avoid overloading the Wave Generator bearing during installation, rotate the Wave Generator as you easily install.
2. Since the Wave Generator of the CSD does not have an Oldham coupling, make sure that the position is within the recommended tolerance shown on page 32.
3. Installation bolts on Wave Generator and installation bolt on Flexspline should not interfere each other.

Circular Spline

1. Be sure flatness and skewness are minimized.
2. Make sure there are no burrs or foreign substances.
3. Make sure there is enough room to have the minimum clearance in the housing.
4. Make sure that the Circular Spline can rotate in the housing when it is installed.
5. When a bolt is inserted into a bolt hole, make sure that the bolt hole is located properly.
7. Bolts should not be tightened at the same time. Apply half of the recommended torque to tighten bolts, and then tighten bolts at the recommended torque. The order of tightening bolts should be done diagonally.

Flexspline

1. Be sure flatness and skewness are minimized.
2. Make sure there are no burrs or foreign substances.
3. Make sure there is enough room to have the minimum clearance in the housing.
4. When a bolt is inserted into a bolt hole, make sure that the bolt hole is located properly.
5. Bolts should not be tightened at the same time. Apply half of the recommended torque to tighten bolts, and then tighten bolts at recommended torque. The order of tightening bolts should be done diagonally.

Make sure that Circular Spline and Flexspline mesh properly.

Do not damage the Flexspline during assembly.

Note to prevent corrosion

The standard SHD has not been treated for preventing corrosion. If needed, apply rust prevention on metal surfaces. As a special order, Harmonic Drive LLC can provide stainless steel components or surface treatments.

Sold & Serviced By: Avoid using pins to secure the Circular Spline if possible.

Efficiency

The efficiency depends on the conditions shown below. Efficiency depends on gear ratio, input speed, load torque, temperature, quantity of lubricant and type of lubricant.

Measurement Condition for Efficiency Graphs

Installation: Based on recommended tolerance
 Load Torque: Rated Torque
 Lubricant: Harmonic Grease SK-1A (size 20 and up)
 Harmonic Grease SK-2 (size 14, 17)
 Harmonic Grease 4B No.2 (SHD Output Bearing)
 Grease quantity: Recommended quantity

Please contact us for details pertaining to recommended oil lubricant for CSD.

CSD Series

Ratio 50

Size 14

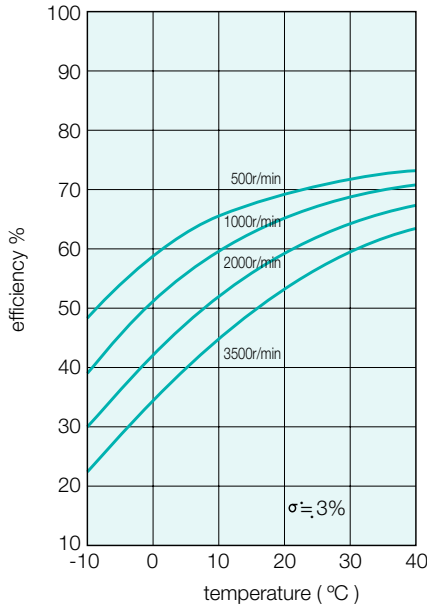

Size 17, 20

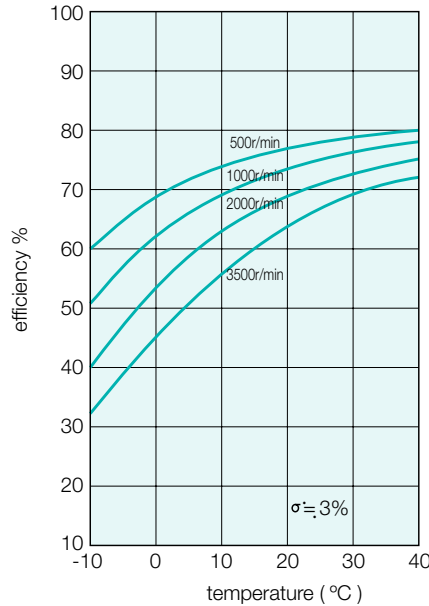

Size 25, 32, 40, 50

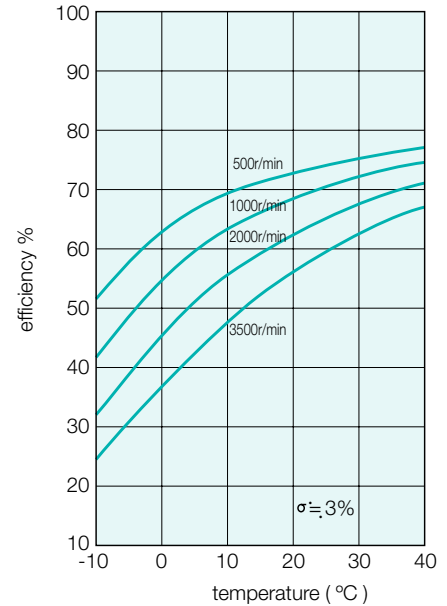

Ratio 100

Size 14

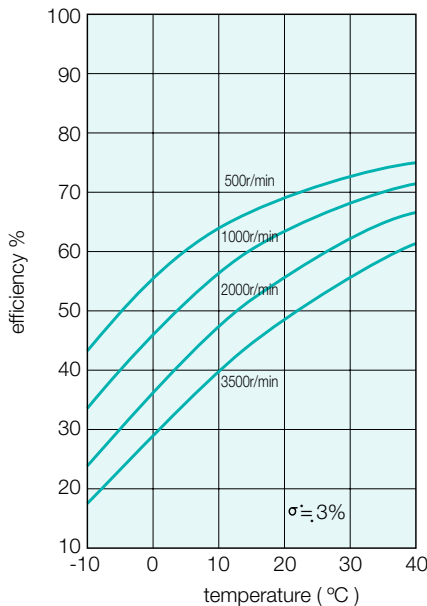

Size 17, 20, 25, 32, 40, 50

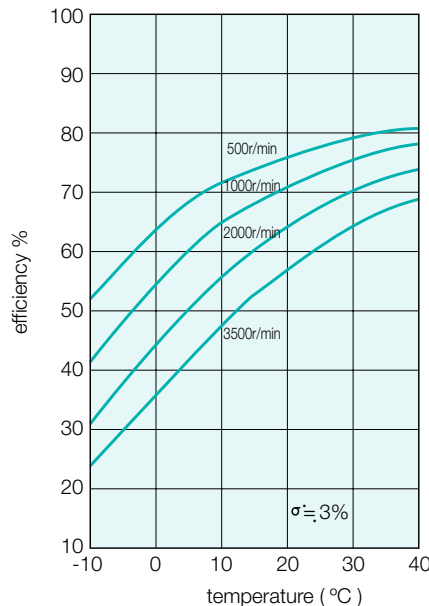

Ratio 160

Size 20, 25, 32, 40, 50

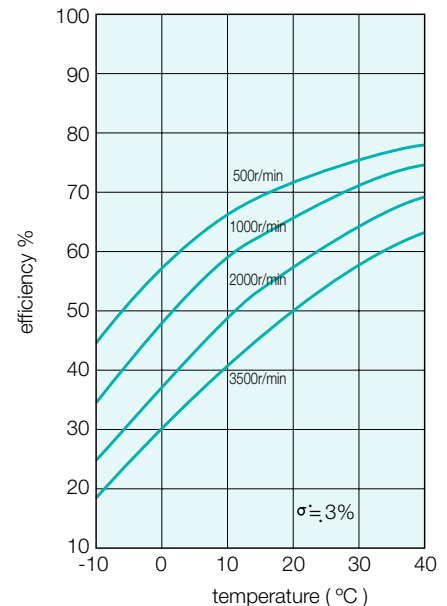

Compensation Coefficient for Other Load Conditions

The efficiency varies with load torque. For the efficiency at various torque loads, use the appropriate compensation coefficient.

CSD Series

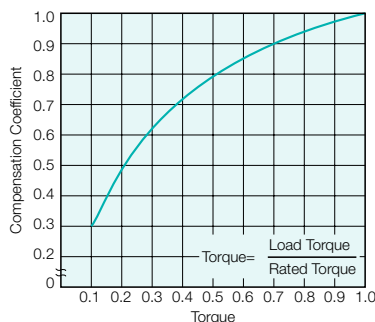

SHD Series

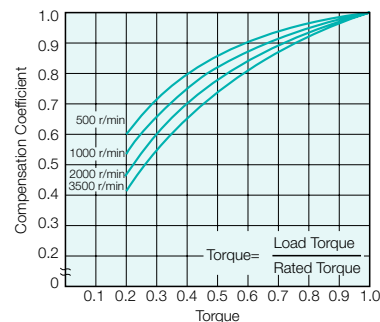

SHD Series

Ratio 50

Size 14

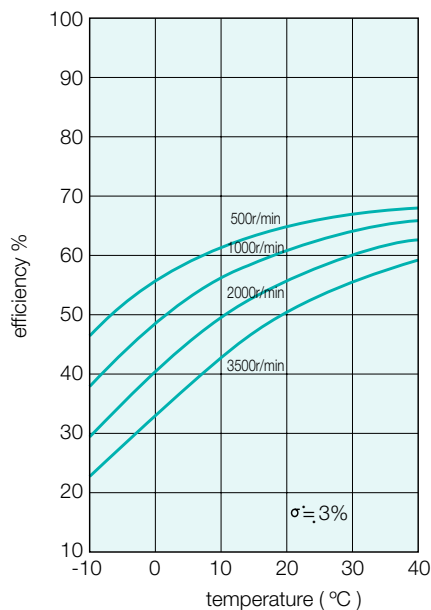

Size 17, 20, 25, 32, 40

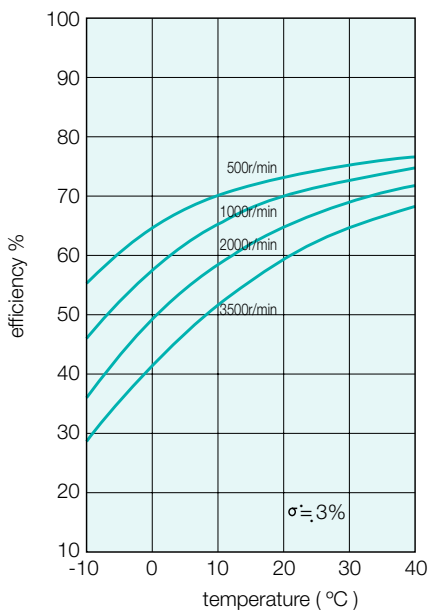

Ratio 100

Size 14

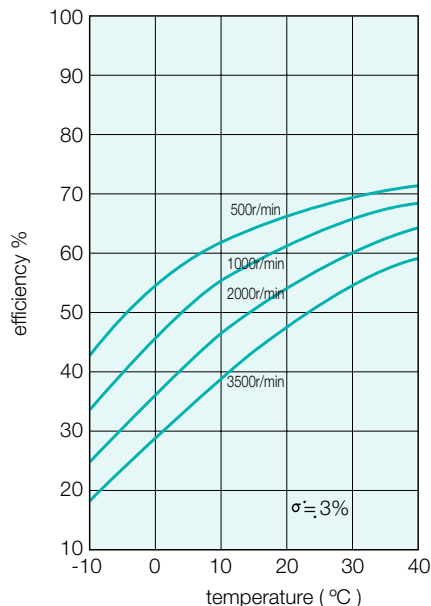

Size 17, 20, 25, 32, 40

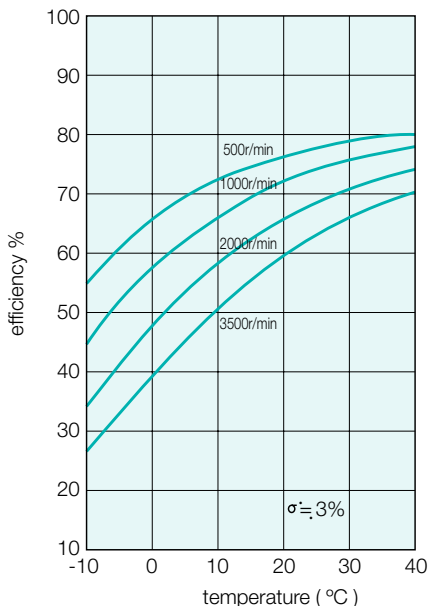

Ratio 160

Size 20, 25, 32, 40

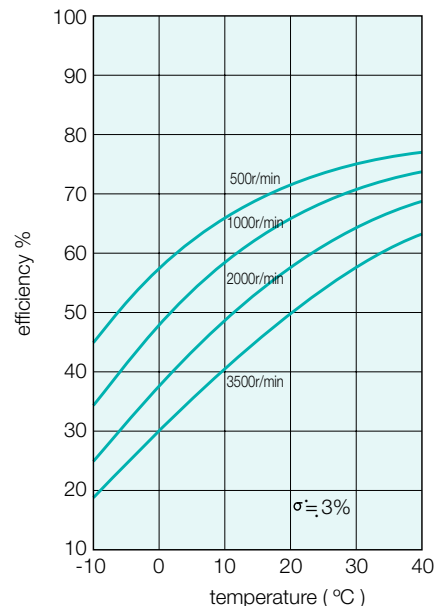

Efficiency (@ Torque \neq Rated Torque) = Efficiency (from graph) x Compensation Coefficient (from graph)

No Load Running Torque (NLRT)

No load running torque indicates the torque which is needed to rotate input of the gear, "Wave Generator", with no load on the output side (low speed side). Please contact us regarding details.

Measurement Condition for NLRT Graphs

Ratio: 100 : 1
 Lubricant: Harmonic Grease SK-1A (size 20 and up)
 Harmonic Grease SK-2 (size 14, 17)
 Harmonic Grease 4B No.2 (SHD Output Bearing)
 Grease quantity: Recommended quantity

Torque value is measured after 2 hours at 2000rpm input.
 Please contact us for details pertaining to recommended oil lubricant for CSD.

CSD Series

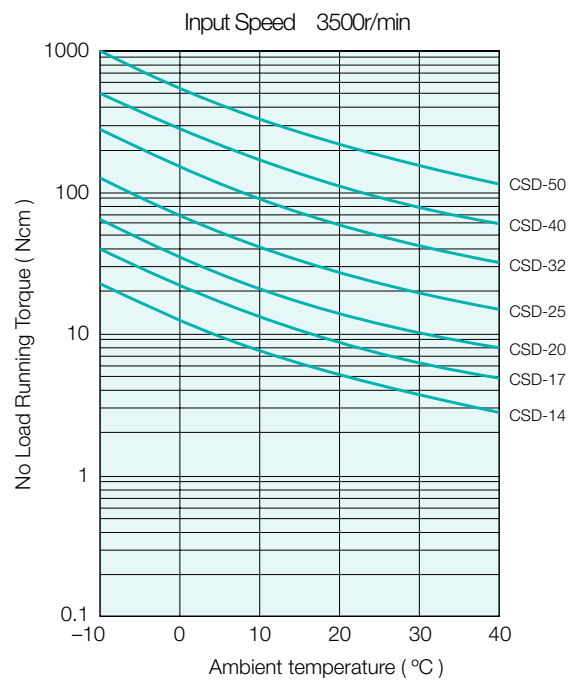
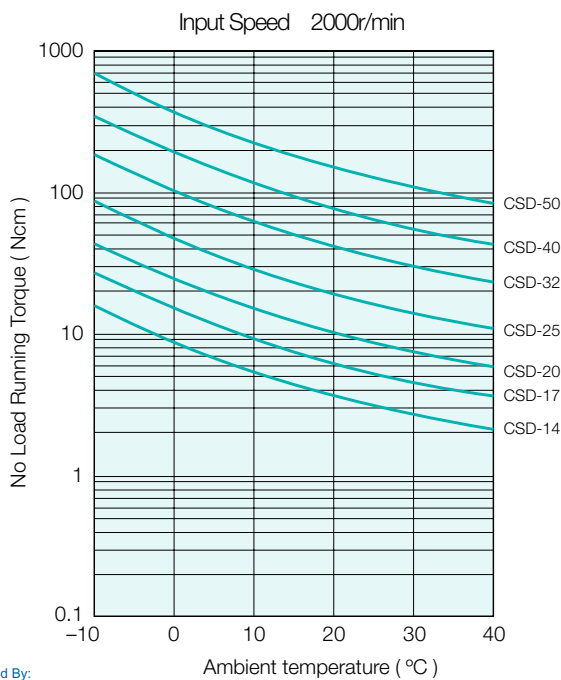
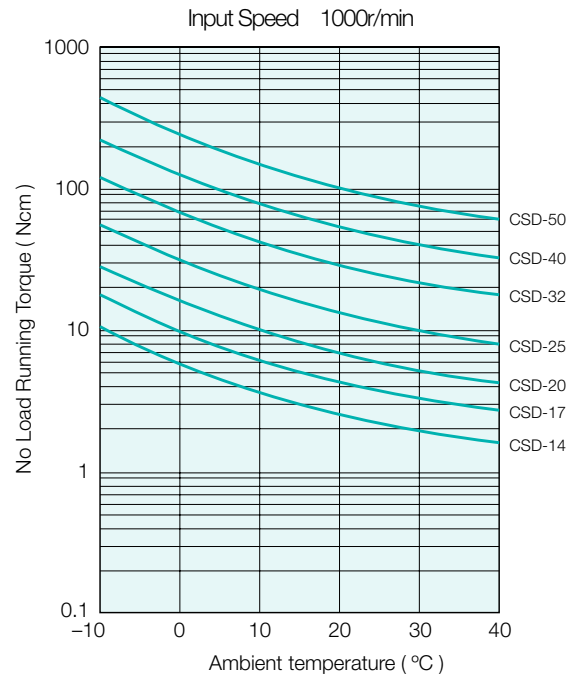
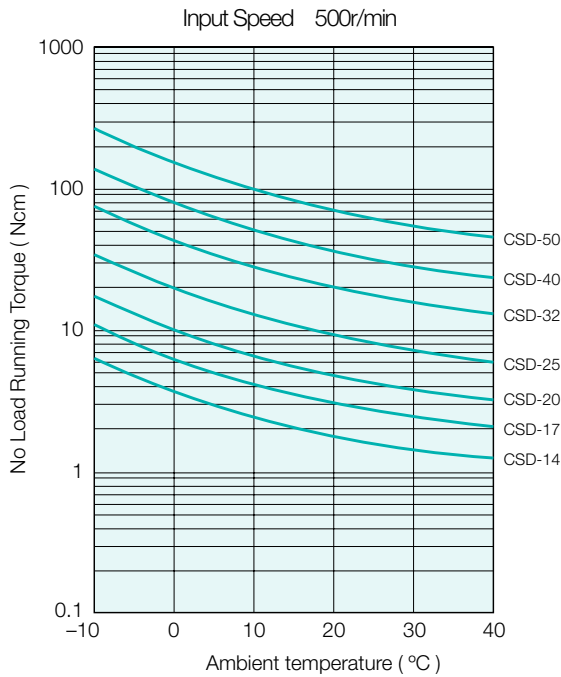

Compensation Value in Each Ratio

No load running torque of the gear varies with ratio. The graphs indicate a value for ratio 100. For other ratios, add the compensation values from the table on the right.

No Load Running Torque Compensation Value

N*cm

Size \ Ratio	50		160	
	CSD	SHD	CSD	SHD
14	+0.56	+1.0	-	-
17	+0.95	+1.6	-	-
20	+1.4	+2.4	-0.39	-0.7
25	+2.6	+4.0	-0.72	-1.2
32	+5.4	+7.0	-1.5	-2.4
40	+9.6	+13	-2.6	-3.9
50	+18	-	-4.8	-

SHD Series

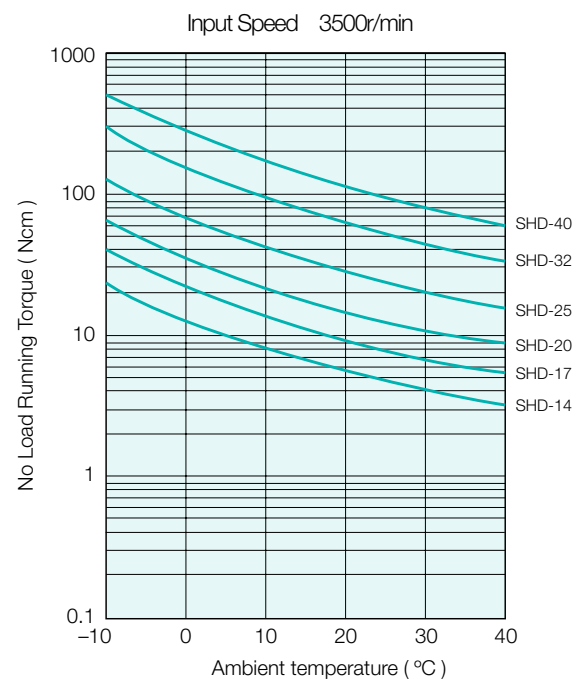
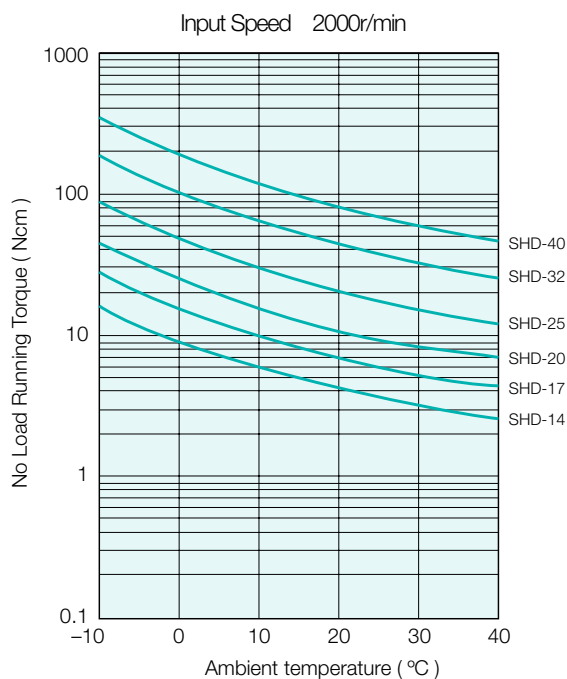
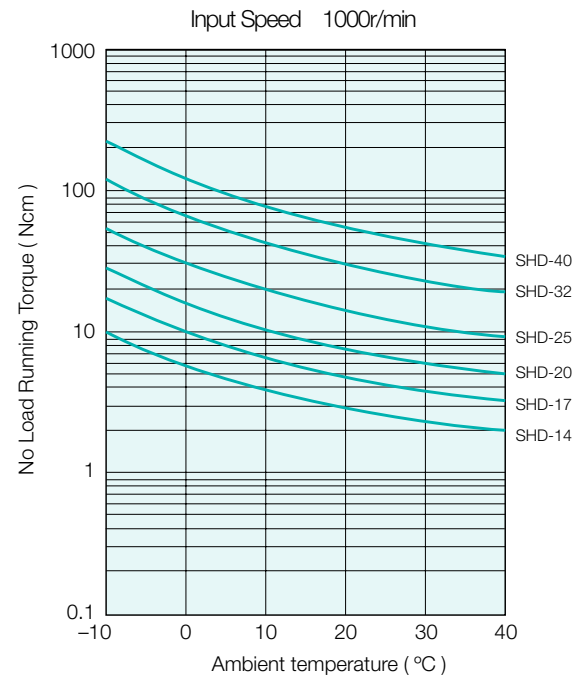
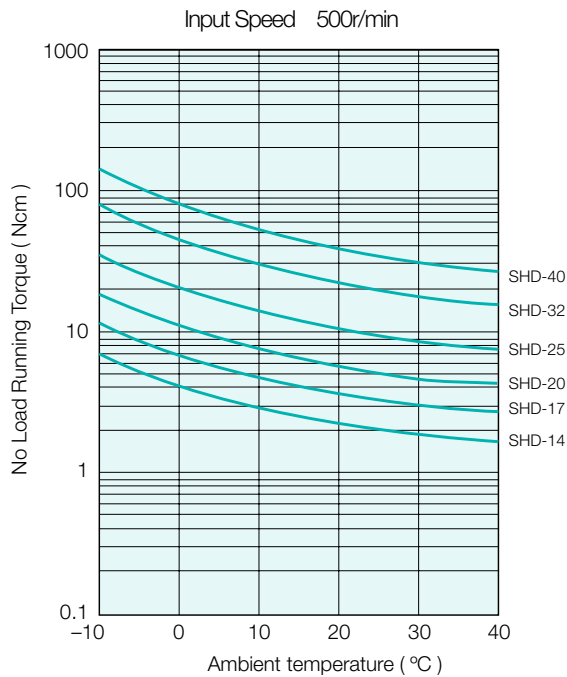

Starting Torque

Starting torque is the torque required to commence rotation of the input element (high speed side), with no load being applied to the output. The table below indicates the maximum values. The lower values are approximately 1/2 to 1/3 of the maximum values.

Component Type Backdriving Torque

Backdriving torque is the torque required to commence rotation of input element (high speed side) when torque is applied on the output side (low speed side). The table below indicates the maximum values. The typical values are approximately 1/2 to 1/3 of the maximum values. The backdriving torque should not be relied upon to provide a holding torque to prevent the output from backdriving. A failsafe brake should be used for this purpose.

Measurement condition: Ambient temperature 20°C

Values shown below vary depending on condition. Please use values as a reference.

Starting Torque for Component Sets (Ncm)

Table 25

Ratio	Size	14	17	20	25	32	40	50
50	CSD	3.7	5.7	7.3	14	28	50	94
	SHD	6.2	19	25	39	60	95	-
100	CSD	2.4	3.3	4.3	7.9	18	29	56
	SHD	4.8	17	22	34	50	78	-
160	CSD	-	-	3.4	6.4	14	24	44
	SHD	-	-	22	33	47	74	-

Backdriving Torque for Component Sets (Nm)

Table 26

Ratio	Size	14	17	20	25	32	40	50
50	CSD	2.5	3.8	4.4	8.3	17	30	57
	SHD	3.7	11	15	24	36	57	-
100	CSD	3.1	4.1	5.2	9.6	21	35	67
	SHD	5.8	21	27	41	60	94	-
160	CSD	-	-	6.6	12	28	45	85
	SHD	-	-	42	64	91	143	-

Positioning Accuracy

The positioning accuracy of the gear represents a linearity error between the input and output angle. The position error is the difference between theoretical and actual output rotation angle.

The positioning accuracy is measured for one complete output revolution using a high resolution measurement system. The measurements are carried out without reversing direction.

The positioning accuracy is defined as the difference between the maximum positive and maximum negative deviation from the theoretical position.

θ_{er}	Positioning Accuracy
θ_1	Input Angle
θ_2	Actual Output Angle
R	Gear Ratio (i= I:R)
$\theta_{er} = \theta_2 - \frac{\theta_1}{R} \quad \text{equation [15]}$	

Typical Positional Accuracy Curve

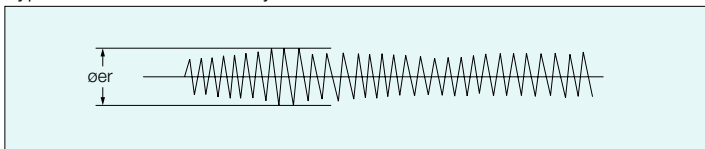

Positioning Accuracy CSD

Table 27

Size		14	17	20	25	32	40	50
Positioning Accuracy	X10 ⁻⁴ rad	4.4	4.4	2.9	2.9	2.9	2.9	2.9
	arc min	1.5	1.5	1.0	1.0	1.0	1.0	1.0

SHD

Table 28

Size		14	17	20	25	32	40
Positioning Accuracy	X10 ⁻⁴ rad	4.4	4.4	2.9	2.9	2.9	2.9
	arc min	1.5	1.5	1.0	1.0	1.0	1.0

Torsional Stiffness

Torsional stiffness is determined by applying a load to the output of the gear, with the input rotationally locked. The angular rotation is measured as the load is increased. The typical curve (shown in the figure 21) is non-linear. The stiffness is determined by the slope of this curve. For simplicity, the curve is approximated by 3 straight lines having stiffness of K₁, K₂, and K₃. Stiffness K₁ applies for output torque of 0 to T₁. Stiffness K₃ applies for output torque greater than T₂. Stiffness K₂ applies for output torque between T₁ and T₂. Typical stiffness values are shown in tables 29 to 32.

Figure 20

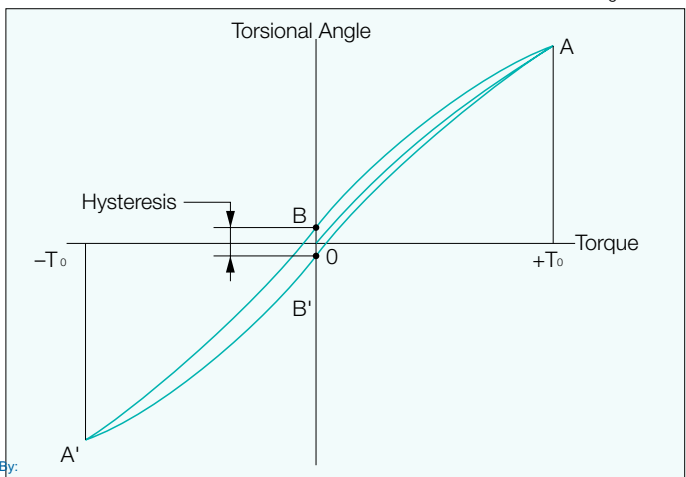
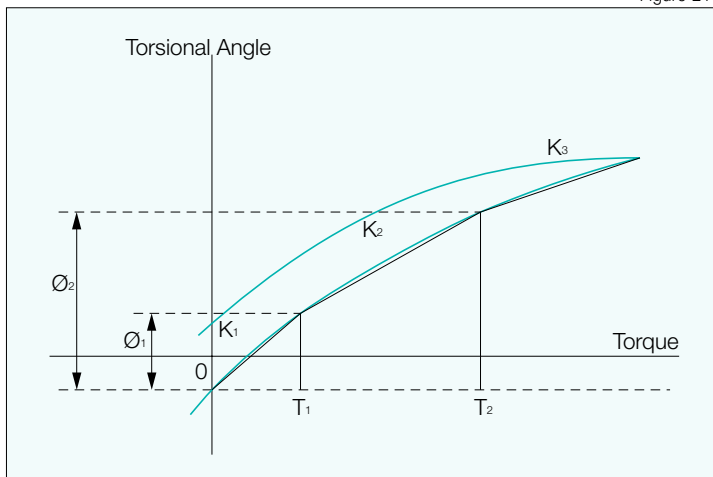

Figure 21



Torsional Stiffness

CSD - Torsional Stiffness for Ratio 1/50

Table 29

Size		14	17	20	25	32	40	50
T ₁	Nm	2.0	3.9	7.0	14	29	54	108
K ₁	X10 ⁻⁴ Nm/rad	0.29	0.67	1.1	2.0	4.7	8.8	17
Ø ₁	X10 ⁻⁴ rad	6.9	5.8	6.4	7.0	6.2	6.1	6.4
	arc min	2.4	2.0	2.2	2.4	2.1	2.1	2.2
T ₂	Nm	6.9	12	25	48	108	196	382
K ₂	X10 ⁻⁴ Nm/rad	0.37	0.88	1.3	2.7	6.1	11	21
Ø ₂	X10 ⁻⁴ rad	19	14	19	18	18	18	18
	arc min	6.4	4.6	6.6	6.1	6.1	5.9	6.2
K ₃	X10 ⁻⁴ Nm/rad	0.47	1.2	2.0	3.7	8.4	15	30

Numbers are average value.

CSD - Torsional Stiffness for Ratio 1/100 and up

Table 30

Size		14	17	20	25	32	40	50
T ₁	Nm	2.0	3.9	7.0	14	29	54	108
K ₁	X10 ⁻⁴ Nm/rad	0.4	0.84	1.3	2.7	6.1	11	21
Ø ₁	X10 ⁻⁴ rad	5.0	4.6	5.4	5.2	4.8	4.9	5.1
	arc min	1.7	1.6	1.8	1.8	1.7	1.7	1.7
T ₂	Nm	6.9	12	25	48	108	196	382
K ₂	X10 ⁻⁴ Nm/rad	0.44	0.94	1.7	3.7	7.8	14	29
Ø ₂	X10 ⁻⁴ rad	16	13	15	13	14	14	13
	arc min	5.4	4.3	5.0	4.5	4.8	4.8	4.6
K ₃	X10 ⁻⁴ Nm/rad	0.61	1.3	2.5	4.7	11	20	37

Numbers are average value.

SHD - Torsional Stiffness for Ratio 1/50

Table 31

Size		14	17	20	25	32	40
T ₁	Nm	2.0	3.9	7.0	14	29	54
K ₁	X10 ⁻⁴ Nm/rad	0.29	0.67	1.1	2.0	4.7	8.8
Ø ₁	X10 ⁻⁴ rad	6.9	5.8	6.4	7.0	6.2	6.1
	arc min	2.4	2.0	2.2	2.3	2.1	2.1
T ₂	Nm	6.9	12	25	48	108	196
K ₂	X10 ⁻⁴ Nm/rad	0.37	0.88	1.3	2.7	6.1	11
Ø ₂	X10 ⁻⁴ rad	19	14	19	18	18	18
	arc min	6.4	4.6	6.3	6.1	6.1	5.9
K ₃	X10 ⁻⁴ Nm/rad	0.47	1.2	2.0	3.7	8.4	15

Numbers are average value.

SHD - Torsional Stiffness for Ratio 1/100 and up

Table 32

Size		14	17	20	25	32	40
T ₁	Nm	2.0	3.9	7.0	14	29	54
K ₁	X10 ⁻⁴ Nm/rad	0.4	0.84	1.3	2.7	6.1	11
Ø ₁	X10 ⁻⁴ rad	5.0	4.6	5.4	5.2	4.8	4.9
	arc min	1.7	1.6	1.8	1.8	1.7	1.7
T ₂	Nm	6.9	12	25	48	108	196
K ₂	X10 ⁻⁴ Nm/rad	0.44	0.94	1.7	3.7	7.8	14
Ø ₂	X10 ⁻⁴ rad	16	13	15	13	14	14
	arc min	5.4	4.3	5.0	4.5	4.8	4.8
K ₃	X10 ⁻⁴ Nm/rad	0.61	1.3	2.5	4.7	11	20

Numbers are average value.

Sold & Serviced By:

 **ELECTROMATE**

Toll Free Phone (877) SERV098

Toll Free Fax (877) SERV099

www.electromate.com

sales@electromate.com

Calculate Torsion Angle

1. For $T < T_1$: $\emptyset = T/K_1$
2. For $T_1 < T < T_2$: $\emptyset = T_1/K_1 + (T - T_1)/K_2$
3. For $T_2 < T$: $\emptyset = T_1/K_1 + (T_2 - T_1)/K_1 + (T - T_2)/K_3$

Note: Units for T, T₁, T₂, K, K₁, K₂, K₃, and \emptyset must be consistent.

Hysteresis Loss

A typical hysteresis curve is shown in figure 20. With the input locked, a torque is applied from 0 to \pm Rated Torque. Hysteresis measurement is shown in the figure. The following table shows typical hysteresis values.

Hysteresis Loss Table 33

Size		14	17	20	25	32	40	50
50	X10 ⁻⁴ rad	7.3	4.4	4.4	4.4	4.4	4.4	4.4
	arc min	2.5	1.5	1.5	1.5	1.5	1.5	1.5
100 and up	X10 ⁻⁴ rad	5.8	2.9	2.9	2.9	2.9	2.9	2.9
	arc min	2.0	1.0	1.0	1.0	1.0	1.0	1.0

All products are warranted to be free from design or manufacturing defects for a period of one year from the date of shipment. Such items will be repaired or replaced at the discretion of Harmonic Drive LLC. The seller makes no warranty, expressed or implied, concerning the material to be furnished other than it shall be of the quality and specifications stated. The seller's liability for any breach is limited to the purchase price of the product. All efforts have been made to assure that the information in this catalog is complete and accurate. However, Harmonic Drive LLC is not liable for any errors, omissions or inaccuracies in the reported data. Harmonic Drive LLC reserves the right to change the product specifications, for any reason, without prior notice.

