

HarmonicPlanetary® HPG Input Shaft

Size

11, 14, 20, 32, 50, 65

6
Sizes

Peak torque

3.9Nm – 2200Nm

Reduction ratio

Single Stage: 3:1 to 9:1, Two Stage: 11:1 to 50:1

High efficiency

Up to 97%

Low backlash

Standard: <3 arc-min Optional: <1 arc-min

Low Backlash for Life

Innovative ring gear automatically adjusts for backlash, ensuring consistent, low backlash for the life of the gearhead. The ring gear design automatically provides the optimum backlash in the planetary gear train and maintains the same low backlash for the life of the gearhead.

High Load Capacity Output Bearing

A Cross Roller bearing is integrated with the output flange to provide high moment stiffness, high load capacity and precise positioning accuracy.

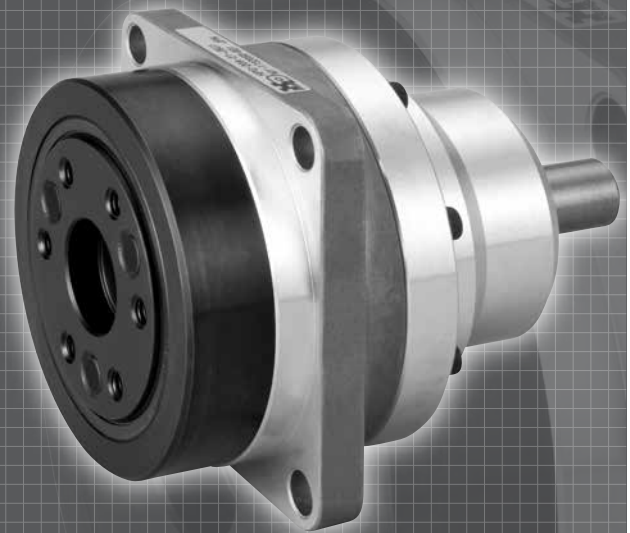

CONTENTS

Rating Table.....	2
Performance.....	3
Backlash and Torsional Stiffness.....	4
Outline Dimensions.....	5-8
Product Sizing & Selection.....	9-10

HPG - 20 A - 05 - BL3 - J2 U1 - SP1

Model Name	Size	Design Revision	Reduction Ratio	Backlash	Output Configuration	Input Configuration	Options
HarmonicPlanetary® HPG Input Shaft	11	B	5, 9, 21, 37, 45	BL1: Backlash less than 1 arc-min (Sizes 14 to 65)	F0: Flange output J20: Shaft output without key J60: Shaft output with key and center tapped hole	U1: Input shaft (with key; no center tapped hole)	None: Standard item SP: Special specification
	14	A	3, 5, 11, 15, 21, 33, 45	BL3: Backlash less than 3 arc-min	F0: Flange output J2: Shaft output without key J6: Shaft output with key and center tapped hole (J2, J6 for Size 65 is also available)	U1: Input shaft (with key and center tapped hole)	
	20						
	32						
	50						
65	4, 5, 12, 15, 20, 25, 40, 50						

Gearhead Construction

Figure 100-1

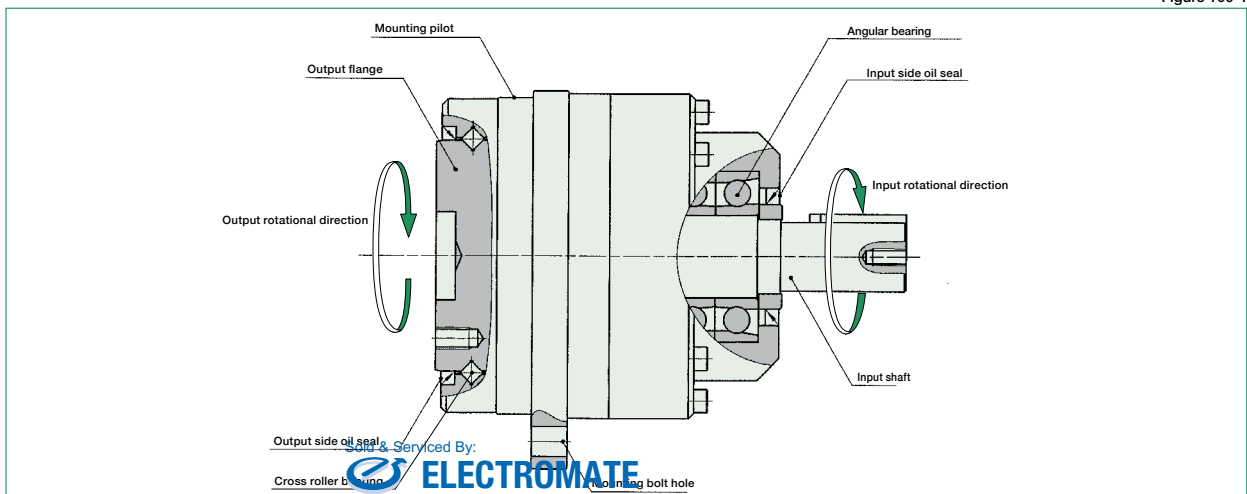

Output side oil seal Serviced By:
ELECTROMATE
Cross roller bearing Input shaft hole

Toll Free Phone (877) SERV098

Toll Free Fax (877) SERV099

www.electromate.com

sales@electromate.com

Rating Table

Table 101-1

Size	Ratio	Rated Torque*1	Limit for Average Torque*2	Limit for Repeated Peak Torque*3	Limit for Momentary Torque*4	Max. Average Input Speed*5	Max. Input Speed*6	Input Moment of Inertia *7		Mass *8	
		Nm	Nm	Nm	Nm	rpm	rpm	Shaft ×10 ⁻⁴ kgm ²	Flange ×10 ⁻⁴ kgm ²	Shaft kg	Flange kg
11	5	2.5	5.0	7.8	20	3000	10000	0.0087	0.0072	0.24	0.20
	9	2.5	3.9	3.9				0.0063	0.0058		
	21	3.4	6.0	9.8				0.0064	0.0063	0.30	0.26
	37	3.4						0.0052	0.0052		
	45	3.4						0.0050	0.0050		
14	3	2.9	6.4	15	37	3000	5000	0.12	0.11	0.80	0.70
	5	5.9	13	15	23		56	6000	0.073		
	11	7.8	0.059						0.058		
	15	9.0	0.057						0.056	0.90	0.80
	21	8.8	0.049						0.049		
	33	10	0.043						0.043		
	45	10									
20	3	8.8	19	64	124	3000	4000	0.80	0.69	2.4	2.0
	5	16	35	100	217		6000	0.44	0.40		
	11	20	45					0.32	0.31	2.7	2.1
	15	24	53					0.30	0.30		
	21	25	55					0.23	0.23		
	33	29	60					0.19	0.19		
	45	29		0.18	0.18						
32	3	31	71	225	507	3000	3600	4.2	3.4	6.3	4.9
	5	66	150	300	650		6000	2.4	2.2		
	11	88	170					6.9	5.3		
	15	92								1.8	1.8
	21	98								1.5	1.5
	33	108	200					1.3	1.3		
	45	108									
50	3	97	195	657	1200	2000	3000	21	18	17	14
	5	170	340	850	1850		4500	11	9.2		
	11	200	400					7.4	7.1	19	16
	15	230	450					6.8	6.7		
	21	260	500					5.5	5.4		
	33	270						4.4	4.3		
	45	270		4.3	4.3						
65 ⁹	4	500	900	2200	4500	2000	2500	58	44	43	33
	5	530	1000				43	34			
	12	600	1100				33	32	58	48	
	15	730	1300				32	31			
	20	800	1500				22	21			
	25	850					21	21			
	40	640	1300				16	16			
	50	750	1500				2200	16	16		

*1: Rated torque is based on L₁₀ life of 20,000 hours at max average input speed.

*2: Maximum value of average load torque is based on the load torque pattern. Note that exceeding this value may deteriorate the life or durability of the product.

*3 The limit for torque during start and stop cycles.

*4: The limit for torque during emergency stops or from external shock loads. Always operate below this value. Calculate the number of permissible events to ensure it meets required operating conditions.

*5: Maximum average input speed is limited by heat generation in the speed reducer assuming a continuous operating speed or the average input speed of a motion profile. The actual limit for average input speed depends on the operating environment.

*6: Maximum instantaneous input speed.

*7: Inertia value is for the gearhead only (without input shaft coupling). Please contact us for the inertia of your specific configuration.

*8: The mass is for the gearhead only (without input shaft coupling & motor flange). Please contact us for the mass of your specific configuration.

*9: Flange output is standard for the size 65 gearhead. Shaft type (J2 & J6) is also available.

Sold & Serviced By:



Toll Free Phone (877) SERV098

Toll Free Fax (877) SERV099

www.electromate.com

sales@electromate.com

Performance Table

Table 102-1

Model	Reduction Ratio	Accuracy *1		Repeatability *2 arc sec	Starting torque *3		Backdriving torque *4		No-load running torque *5	
		arc min	×10 ⁻³ rad		Ncm	kgfcm	Nm	kgfm	Ncm	kgfcm
11	5	5	14.5	±30	7.9	0.81	0.40	0.040	8.9	0.91
	9				7.6	0.77	0.68	0.069	6.3	0.65
	21				6.8	0.69	1.4	0.14	5.2	0.53
	37				5.5	0.57	2.0	0.21	4.8	0.49
	45				5.3	0.55	2.4	0.25	4.7	0.48
14	3	4	11.6	±20	22	2.2	0.66	0.067	26	2.7
	5				17	1.7	0.83	0.085	15	1.5
	11				16	1.6	1.8	0.18	10	1.0
	15				15	1.5	2.3	0.23	8.2	0.84
	21				13	1.4	2.9	0.30		
	33				11	1.2	3.8	0.39	7.3	0.74
	45				11	1.1	4.8	0.49		
20	3	4	11.6	±15	46	4.7	1.4	0.14	61	6.2
	5				34	3.4	1.7	0.17	39	4.0
	11				30	3.1	3.3	0.34	26	2.6
	15				27	2.8	4.0	0.41	22	2.2
	21				24	2.5	5.1	0.52	20	2.0
	33				21	2.2	7.1	0.72	17	1.7
	45				20	2.0	8.9	0.91	16	1.6
	3				92	9.4	2.8	0.28	146	15
32	5	4	11.6	±15	69	7.1	3.5	0.35	100	10
	11				63	6.4	6.9	0.70	66	6.8
	15				61	6.2	9.1	0.93	57	5.9
	21				58	6.0	12	1.3	52	5.3
	33				52	5.3	17	1.7	42	4.3
	45				46	4.8	21	2.1	41	4.2
	3				197	20	5.9	0.60	300	31
	5				140	14	7.0	0.71	180	18
50	11	3	8.7	±15	110	11	12	1.2	110	11
	15				100	10	15	1.5	97	9.9
	21				98	9.8	21	2.1	90	9.2
	33				88	8.9	29	3.0	74	7.6
	45				83	8.4	37	3.8	70	7.1
	4				406	41	16	1.7	576	59
	5				358	36	18	1.8	517	53
	12				243	25	29	3.0	341	35
65	15	3	8.7	±15	228	23	34	3.5	311	32
	20				213	22	43	4.3	282	29
	25				202	21	51	5.2	262	27
	40				193	20	77	7.9	230	24
	50				188	19	94	9.6	219	22

*1: Accuracy values represent the difference between the theoretical angle and the actual angle of output for any given input. The values in the table are maximum values.

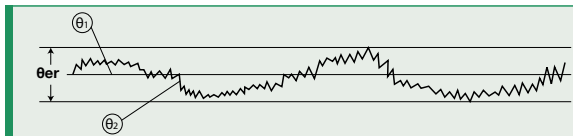

θer : Accuracy
 θ1 : Input angle
 θ2 : Actual output angle
 R : Reduction ratio

$$\theta_{er} = \theta_2 - \frac{\theta_1}{R}$$

Figure 102-1

*2: The repeatability is measured by moving to a given theoretical position seven times, each time approaching from the same direction. The actual position of the output shaft is measured each time and repeatability is calculated as the 1/2 of the maximum difference of the seven data points. Measured values are indicated in angles (arc-sec) prefixed with "±". The values in the table are maximum values.

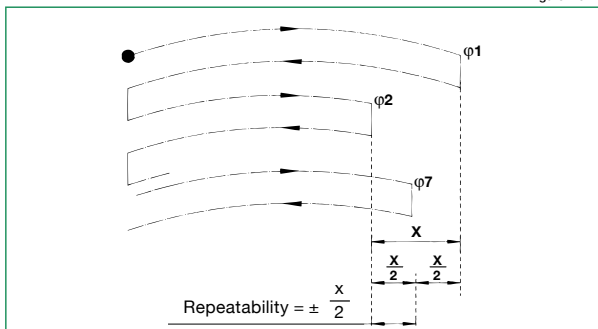

Figure 102-2

*3: Starting torque is the torque value applied to the input side at which the output first starts to rotate. The values in the table are maximum values.

Load	No load
HPG speed reducer surface temperature	25°C

Table 102-2

*4: Backdriving torque is the torque value applied to the output side at which the input first starts to rotate. The values in the table are maximum values.

Note: Never rely on these values as a margin in a system that must hold an external load. A brake must be used where back driving is not permissible.

Load	No load
HPG speed reducer surface temperature	25°C

Table 102-3

*5: No-load running torque is the torque required at the input to operate the gearhead at a given speed under a no-load condition. The values in the table are average values.

Input speed	3000 rpm
Load	No load
HPG speed reducer surface temperature	25°C

Table 102-4

Sold & Serviced By:

Toll Free Phone (877) SERV098

Toll Free Fax (877) SERV099

www.electromate.com

sales@electromate.com

Backlash and Torsional Stiffness

Table 103-1

Input Shaft Gear Unit - Standard backlash (BL3) (≤ 3 arc-min)

Size	Ratio	Backlash		Torsion angle on one side at $T_R \times 0.15$		Torsional stiffness	
				D		A/B	
		arc min	$\times 10^{-4}$ rad	arc min	$\times 10^{-4}$ rad	Nm/arc min	$\times 100$ Nm/rad
11	3.0	3.0	8.7	2.5	7.3	0.59	20
				3.0	8.7	0.64	22
				2.2	6.4	1.27	44
				2.7	7.9	1.37	47
14	3.0	3.0	8.7	1.5	4.4	4.9	170
				2.0	5.8	5.39	180
				1.3	3.8	16.66	570
				1.7	4.9	19.6	670
20	3.0	3.0	8.7	1.3	3.8	82.71	2800
				1.7	4.9	107.8	3700
				1.3	3.8	16.66	570
				1.7	4.9	19.6	670
32	3.0	3.0	8.7	1.3	3.8	82.71	2800
				1.7	4.9	107.8	3700
				1.3	3.8	16.66	570
				1.7	4.9	19.6	670
50	3.0	3.0	8.7	1.3	3.8	82.71	2800
				1.7	4.9	107.8	3700
				1.3	3.8	16.66	570
				1.7	4.9	19.6	670
65	3.0	3.0	8.7	1.3	3.8	82.71	2800
				1.7	4.9	107.8	3700
				1.3	3.8	16.66	570
				1.7	4.9	19.6	670

Table 103-2

Input Shaft Gear Unit - Reduced backlash (BL1) (≤ 1 arc-min)

Size	Ratio	Backlash		Torsion angle on one side at $T_R \times 0.15$		Torsional stiffness	
				D		A/B	
		arc min	$\times 10^{-4}$ rad	arc min	$\times 10^{-4}$ rad	Nm/arc min	$\times 100$ Nm/rad
11		not available					
14	1.0	2.9	2.9	1.1	3.2	1.27	44
				1.7	4.9	1.37	47
				0.6	1.7	4.9	170
				1.1	3.2	5.39	180
20	1.0	2.9	2.9	0.5	1.5	16.66	570
				1.0	2.9	21.56	740
				0.5	1.5	19.6	670
				1.0	2.9	82.71	2800
32	1.0	2.9	2.9	0.5	1.5	16.66	570
				1.0	2.9	21.56	740
				0.5	1.5	19.6	670
				1.0	2.9	82.71	2800
50	1.0	2.9	2.9	0.5	1.5	107.8	3700
				1.0	2.9	137.2	4700
				0.5	1.5	16.66	570
				1.0	2.9	21.56	740
65	1.0	2.9	2.9	0.5	1.5	270	10000
				1.0	2.9	362.6	12500
				0.5	1.5	16.66	570
				1.0	2.9	21.56	740

Torsional stiffness curve

With the input of the gear locked in place, a torque applied to the output flange will torsionally deflect in proportion to the applied torque. We generate a torsional stiffness curve by slowly applying torque to the output in the following sequence:

- (1) Clockwise torque to T_R , (2) Return to Zero, (3) Counter-Clockwise torque to $-T_R$, (4) Return to Zero and (5) again Clockwise torque to T_R .

A loop of (1) > (2) > (3) > (4) > (5) will be drawn as in Fig. 103-1. The torsional stiffness in the region from " $0.15 \times T_R$ " to " T_R " is calculated using the average value of this slope. The torsional stiffness in the region from "zero torque" to " $0.15 \times T_R$ " is lower. This is caused by the small amount of backlash plus engagement of the mating parts and loading of the planet gears under the initial torque applied.

Calculation of total torsion angle

The method to calculate the total torsion angle (average value) on one side when the speed reducer applies a load in a no-load state.

Formula 103-1

● Calculation formula

$$\theta = D + \frac{T - T_L}{A/B}$$

θ	Total torsion angle	-
D	Torsion angle on one side at output torque x 0.15 torque	See Fig. 103-1, Table 103-1 to 2
T	Load torque	-
T_L	Output torque x 0.15 torque (= $T_R \times 0.15$)	See Fig. 103-1
A/B	Torsional stiffness	See Fig. 103-1, Table 103-1 to 2

Backlash (Hysteresis loss)

The vertical distance between points (2) & (4) in Fig. 103-1 is called a hysteresis loss. The hysteresis loss between "Clockwise load torque T_R " and "Counter Clockwise load torque $-T_R$ " is defined as the backlash of the HPG series. The backlash of the HPG series is less than 3 arc-min (1 arc-min or less for a custom product).

Figure 103-1

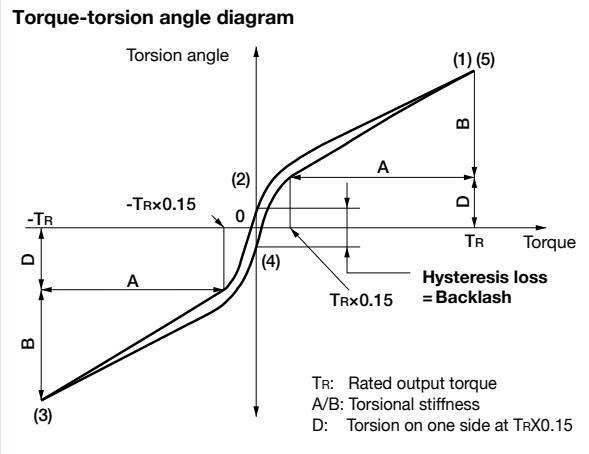

Sold & serviced by:



Toll Free Phone (877) SERV098

Toll Free Fax (877) SERV099

www.electromate.com

sales@electromate.com

Outline Dimensions

Only primary dimensions are shown in the drawings below. Refer to the confirmation drawing for detailed dimensions.

HPG-11 Outline Dimensions

Figure 104-1

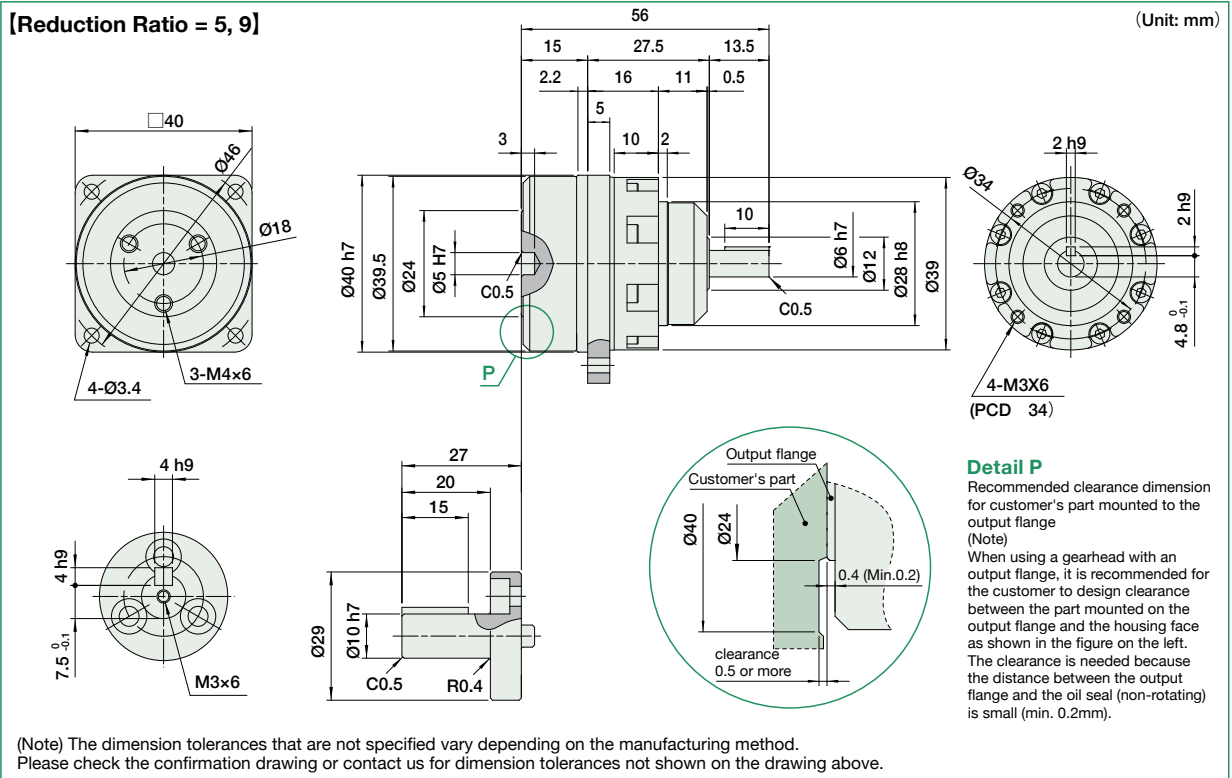
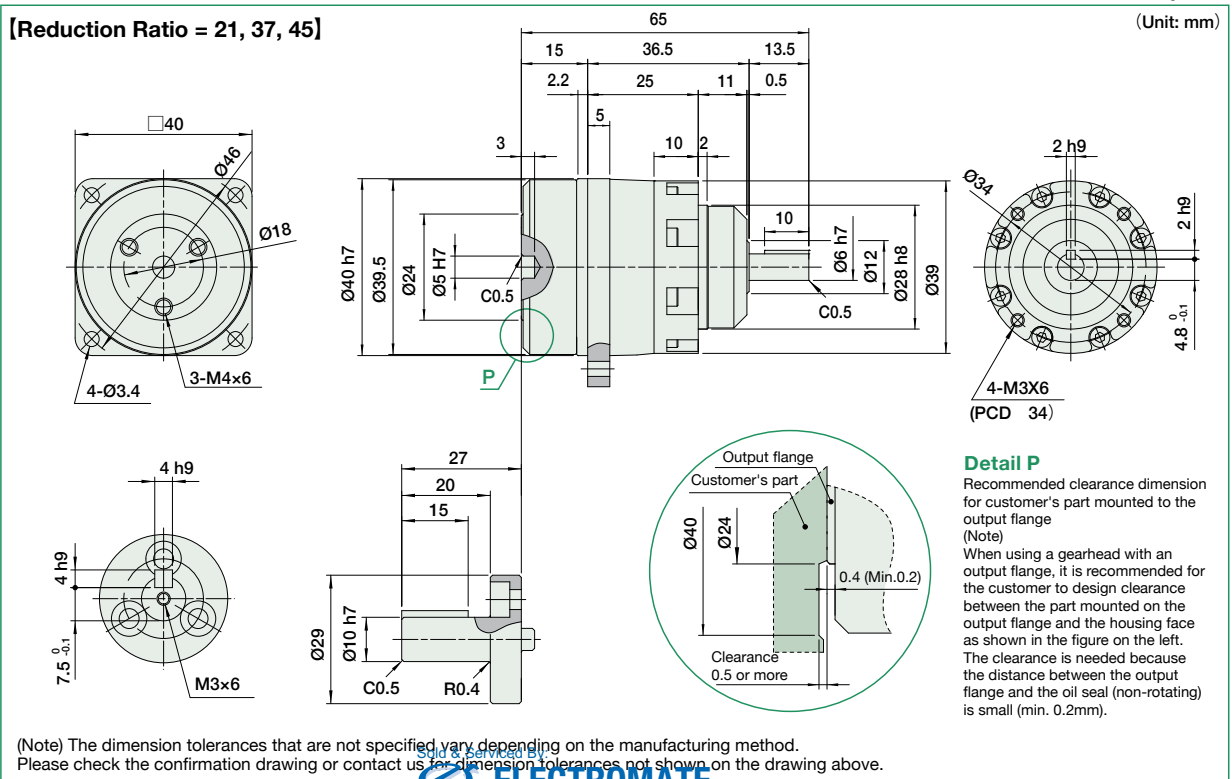

Figure 104-2



Toll Free Phone (877) SERV098
 Toll Free Fax (877) SERV099
www.electromate.com
sales@electromate.com

Outline Dimensions

Only primary dimensions are shown in the drawings below. Refer to the confirmation drawing for detailed dimensions.

HPG-14 Outline Dimensions

Figure 105-1

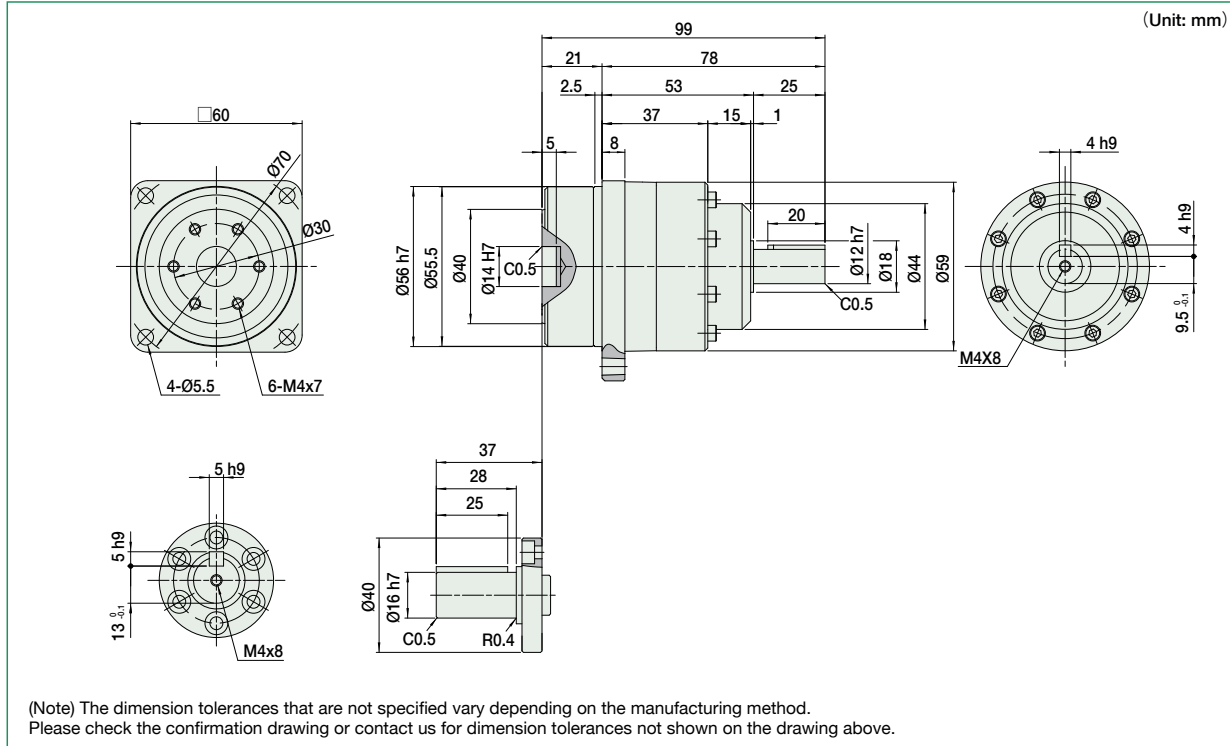

HPG-20 Outline Dimensions

Figure 105-2

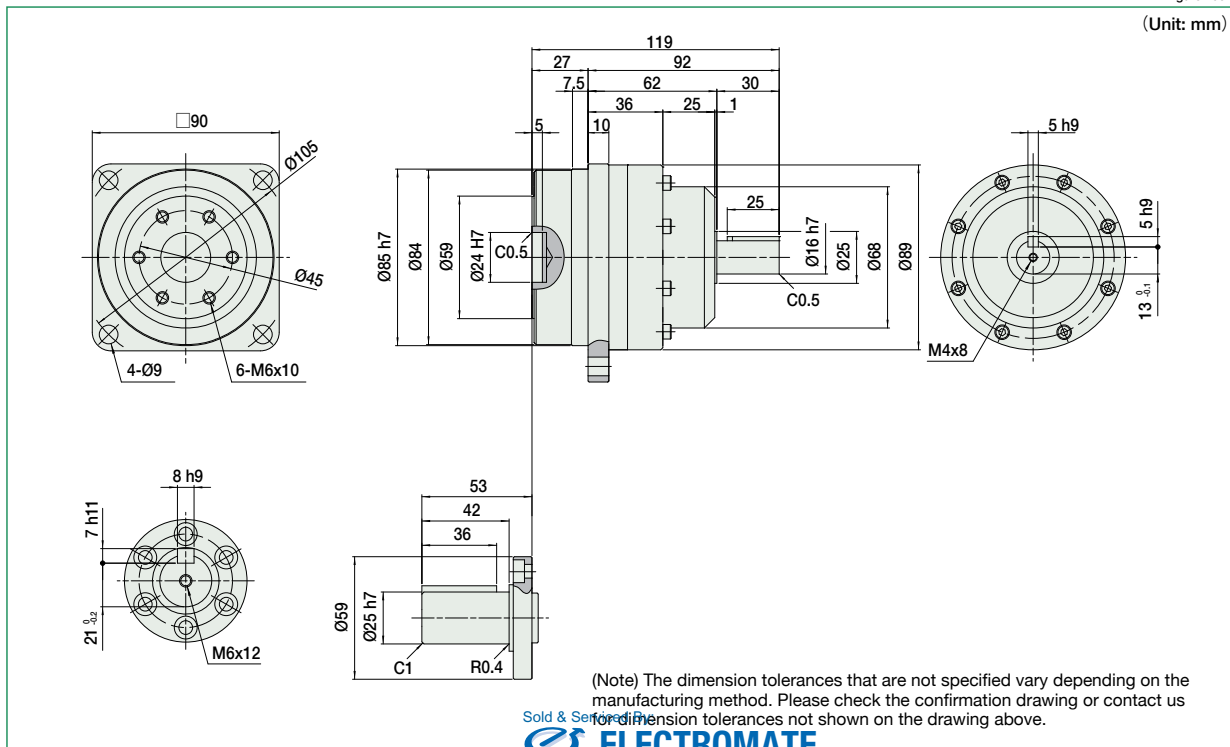

Sold & Serviced by
ELECTROMATE

Toll Free Phone (877) SERV098
 Toll Free Fax (877) SERV099
www.electromate.com
sales@electromate.com

Outline Dimensions

Only primary dimensions are shown in the drawings below. Refer to the confirmation drawing for detailed dimensions.

HPG-32 Outline Dimensions

Figure 106-1

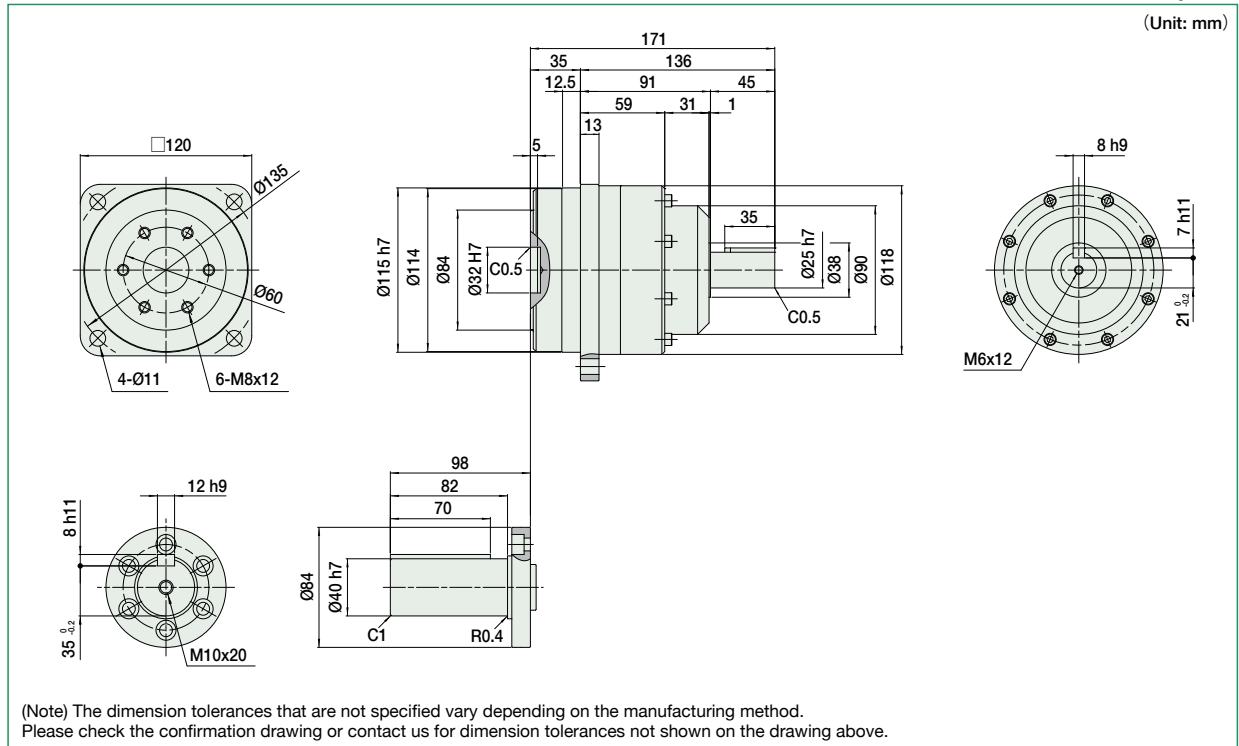

HPG-50 Outline Dimensions

Figure 106-2

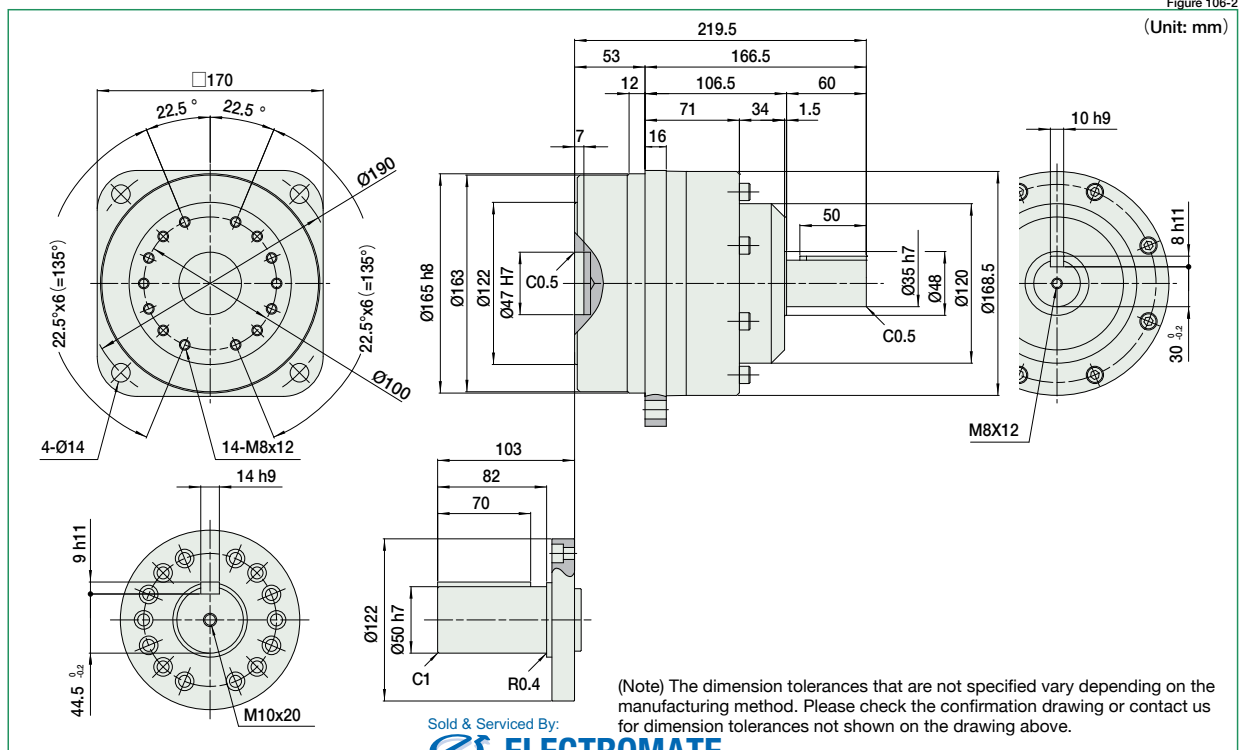

Sold & Serviced By:



Toll Free Phone (877) SERV098

Toll Free Fax (877) SERV099

www.electromate.com

sales@electromate.com

Outline Dimensions

Only primary dimensions are shown in the drawings below. Refer to the confirmation drawing for detailed dimensions.

HPG-65 Outline Dimensions

Figure 107-1

[Reduction Ratio = 4, 5]

(Unit: mm)

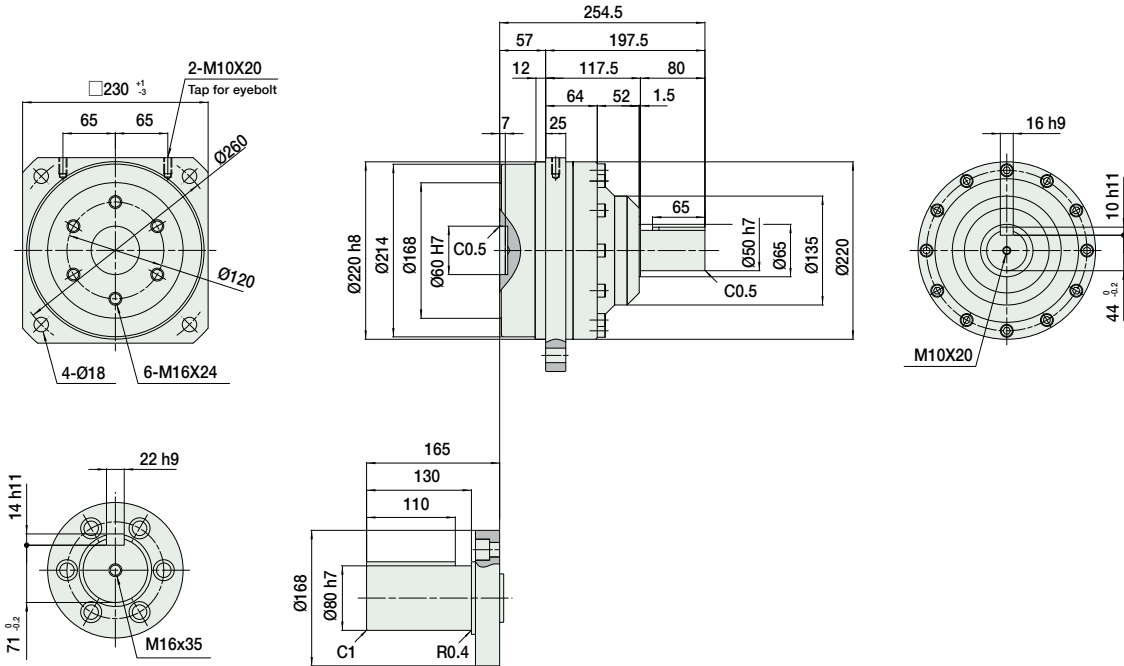

(Note) The dimension tolerances that are not specified vary depending on the manufacturing method. Please check the confirmation drawing or contact us for dimension tolerances not shown on the drawing above.

Figure 107-2

[Reduction Ratio = 12, 15, 20, 25, 40, 50]

(Unit: mm)

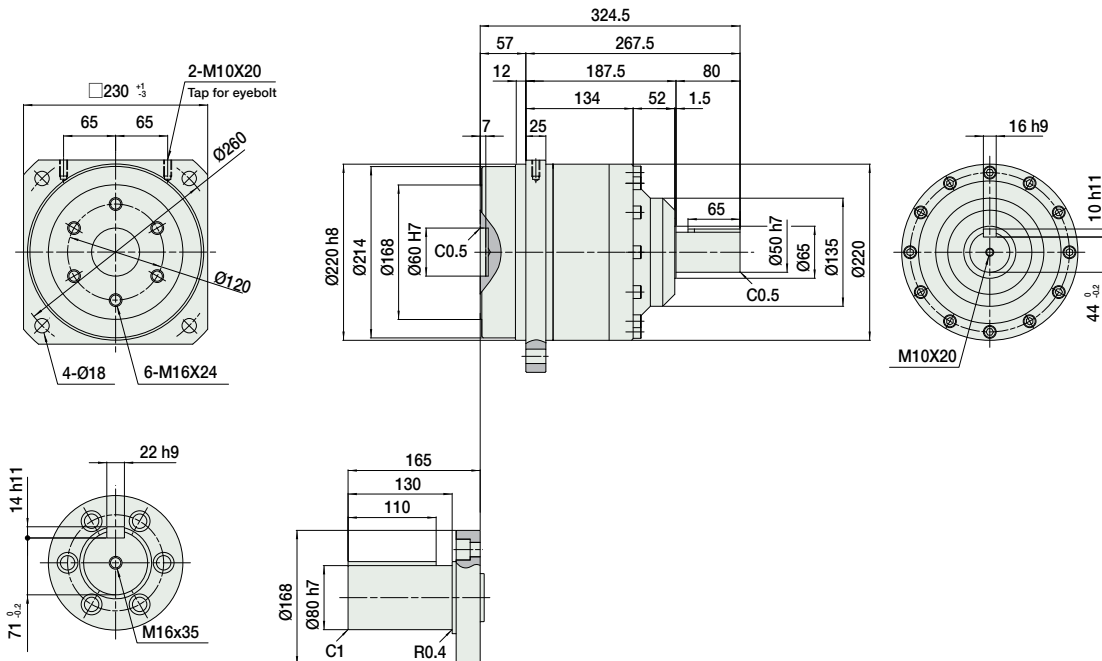

(Note) The dimension tolerances that are not specified vary depending on the manufacturing method. Please check the confirmation drawing or contact us for dimension tolerances not shown on the drawing above.



Toll Free Phone (877) SERV098
 Toll Free Fax (877) SERV099
www.electromate.com
sales@electromate.com

Product Sizing & Selection

To fully utilize the excellent performance of the HPG HarmonicPlanetary® gearheads, check your operating conditions and, using the flowchart, select the appropriate size gear for your application.

In general, a servo system rarely operates at a continuous load and speed. The input speed, load torque change and a comparatively large torque is applied during start and stop. Unexpected impact torques may also be applied.

Check your operating conditions against the following load torque pattern and select a suitable size based on the flowchart shown on the right. Also check the life and static safety coefficient of the cross roller bearing and input side main bearing (input shaft type only).

Checking the load torque pattern

Review the load torque pattern. Check the specifications shown in the figure below.

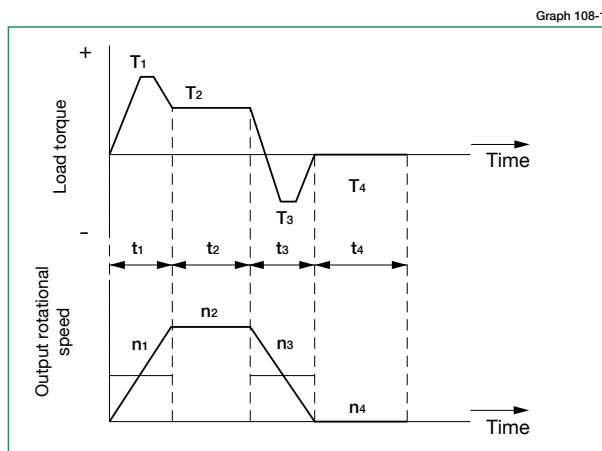

Obtain the value of each load torque pattern.

Load torque	T ₁ to T _n (Nm)
Time	t ₁ to t _n (sec)
Output rotational speed	n ₁ to n _n (rpm)

<Normal operation pattern>

Starting	T ₁ , t ₁ , n ₁
Steady operation	T ₂ , t ₂ , n ₂
Stopping (slowing)	T ₃ , t ₃ , n ₃
Idle	T ₄ , t ₄ , n ₄

<Maximum rotational speed>

Max. output rotational speed	n _{o max} ≥ n ₁ to n _n
Max. input rotational speed	n _{i max} n ₁ × R to n _n × R
(Restricted by motors)	R: Reduction ratio

<Impact torque>

When impact torque is applied T_s

<Required life>

$$L_{10} = L \text{ (hours)}$$

Flowchart for selecting a size

Please use the flowchart shown below for selecting a size. Operating conditions must not exceed the performance ratings.

Calculate the average load torque applied on the output side from the load torque pattern: T_{av} (Nm).

$$T_{av} = \frac{10/3 \sqrt{|n_1| \cdot t_1 \cdot |T_1|^{10/3} + |n_2| \cdot t_2 \cdot |T_2|^{10/3} + \dots + |n_n| \cdot t_n \cdot |T_n|^{10/3}}}{n_1 \cdot t_1 + n_2 \cdot t_2 + \dots + n_n \cdot t_n}$$

Calculate the average output speed based on the load torque pattern: n_{o av} (rpm)

$$n_{o av} = \frac{|n_1| \cdot t_1 + |n_2| \cdot t_2 + \dots + |n_n| \cdot t_n}{t_1 + t_2 + \dots + t_n}$$

Select a preliminary model number with the following condition: T_{av} ≤ Average load torque (See the rating table on page 101)

OK

Determine the reduction ratio (R) based on the maximum output speed (n_{o max}) and maximum input speed (n_{i max}).

$$\frac{n_{i max}}{n_{o max}} \geq R$$

(A limit is placed on n_{i max} by motors.)

Calculate the maximum input speed (n_{i max}) from the maximum output speed (n_{o max}) and the reduction ratio (R).

$$n_{i max} = n_{o max} \cdot R$$

Calculate the average input speed (n_{i av}) from the average output speed (n_{o av}) and the reduction ratio (R): n_{i av} = n_{o av} · R ≤ Max. average input speed (n_i).

OK

Check whether the maximum input speed is equal to or less than the values in the rating table.

n_{i max} ≤ maximum input speed (rpm)

OK

Check whether T₁ and T₃ are equal to or less than the limit for repeated peak torque (Nm) in the rating table.

OK

Check whether T_s is equal to or less than the limit for momentary torque (Nm) in the rating table.

OK

Calculate the lifetime and check whether it meets the specification requirement.

T_r: Output torque

n_i: Max. average input speed

$$L_{10} = 20,000 \cdot \left(\frac{T_r}{T_{av}} \right)^{10/3} \cdot \left(\frac{n_i}{n_{i av}} \right) \text{ (Hour)}$$

OK

The model number is confirmed.

Refer to the Caution note below.

Review the operation conditions, size and reduction ratio.

Caution

If the expected operation will result in conditions where:
 i) Actual average load torque (T_{av}) > Limit for average torque or
 ii) Actual average input rotational speed (n_{i av}) > Maximum average input speed (n_i),
 then please check its effect on the speed reducer temperature rise or other factors. Consider selecting the next larger speed reducer, reduce the operating loads or take other means to ensure safe use of the gear. Exercise caution especially when the duty cycle is close to continuous operation.

Sold & Serviced By:

ELECTROMATE

Toll Free Phone (877) SERV098

Toll Free Fax (877) SERV099

www.electromate.com

sales@electromate.com

Example of Model Number Selection

Value of each load torque pattern.

Load torque	T_n (Nm)	<Maximum rotational speed>	
Time	t_n (sec)	Max. output rotational speed	$n_{o\ max} = 120$ rpm
Output rotational speed	n_n (rpm)	Max. input rotational speed	$n_{i\ max} = 5,000$ rpm (Restricted by motors)
<Normal operation pattern>			
Starting	$T_1 = 70$ Nm, $t_1 = 0.3$ sec, $n_1 = 60$ rpm	<Impact torque>	
Steady operation	$T_2 = 18$ Nm, $t_2 = 3$ sec, $n_2 = 120$ rpm	When impact torque is applied	$T_s = 180$ Nm
Stopping (slowing)	$T_3 = 35$ Nm, $t_3 = 0.4$ sec, $n_3 = 60$ rpm	<Required lifespan>	
Idle	$T_4 = 0$ Nm, $t_4 = 5$ sec, $n_4 = 0$ rpm	$L_{10} = 30,000$ (hours)	

Calculate the average load torque applied on the output side based on the load torque pattern: T_{av} (Nm).

$$T_{av} = \sqrt[10/3]{\frac{|60\text{rpm}| \cdot 0.3\text{sec} \cdot |70\text{Nm}|^{10/3} + |120\text{rpm}| \cdot 3\text{sec} \cdot |18\text{Nm}|^{10/3} + |60\text{rpm}| \cdot 0.4\text{sec} \cdot |35\text{Nm}|^{10/3}}{|60\text{rpm}| \cdot 0.3\text{sec} + |120\text{rpm}| \cdot 3\text{sec} + |60\text{rpm}| \cdot 0.4\text{sec}}}$$

Calculate the average output speed based on the load torque pattern: $n_{o\ av}$ (rpm)

$$n_{o\ av} = \frac{|60\text{rpm}| \cdot 0.3\text{sec} + |120\text{rpm}| \cdot 3\text{sec} + |60\text{rpm}| \cdot 0.4\text{sec} + |0\text{rpm}| \cdot 5\text{sec}}{0.3\text{sec} + 3\text{sec} + 0.4\text{sec} + 5\text{sec}}$$

Make a preliminary model selection with the following conditions. $T_{av} = 30.2\text{Nm} \leq 60\text{Nm}$. (HPG-20A-33 is tentatively selected based on the average load torque (see the rating table on page 101) of model No. 20 and reduction ratio of 33.)

OK

Determine a reduction ratio (R) from the maximum output speed ($n_{o\ max}$) and maximum input speed ($n_{i\ max}$).

$$\frac{5,000\text{ rpm}}{120\text{ rpm}} = 41.7 \geq 33$$

Calculate the maximum input speed ($n_{i\ max}$) from the maximum output speed ($n_{o\ max}$) and reduction ratio (R): $n_{i\ max} = 120\text{ rpm} \cdot 33 = 3,960\text{ rpm}$

OK

Calculate the average input rotational speed ($n_{i\ av}$) from the average output speed ($n_{o\ av}$) and reduction ratio (R):

$$n_{i\ av} = 46.2\text{ rpm} \cdot 33 = 1,525\text{ rpm} \leq \text{Max. average input speed of size 20 } 3,000\text{ (rpm)}$$

OK

Check whether the maximum input speed is equal to or less than the values specified in the rating table.

$$n_{i\ max} = 3,960\text{ rpm} \leq 6,000\text{ rpm (maximum input rotational speed of size 20)}$$

OK

Check whether T_1 and T_3 are equal to or less than the peak torques (Nm) on start and stop in the rating table.

$$T_1 = 70\text{ Nm} \leq 100\text{ Nm (Limit for repeated torque, size 20)}$$

$$T_3 = 35\text{ Nm} \leq 100\text{ Nm (Limit for repeated torque, size 20)}$$

OK

Check whether T_s is equal to or less than the values of the momentary max. torque (Nm) in the rating table.

$$T_s = 180\text{ Nm} \leq 217\text{ Nm (momentary max. torque of size 20)}$$

OK

Calculate life and check whether the calculated life meets the requirement.

$$L_{10} = 20,000 \cdot \left(\frac{29\text{ Nm}}{30.2\text{ Nm}}\right)^{10/3} \cdot \left(\frac{3,000\text{ rpm}}{1,525\text{ rpm}}\right) = 34,543\text{ (hours)} \geq 30,000\text{ (hours)}$$

OK

The selection of model number HPG-20A-33 is confirmed from the above calculations.

Refer to the Caution note at the bottom of page 108.

Review the operation conditions, size and reduction ratio.

Sold & Serviced By:

 **ELECTROMATE**

Toll Free Phone (877) SERV098

Toll Free Fax (877) SERV099

www.electromate.com

sales@electromate.com

Output Bearing Specifications and Checking Procedure

A precision cross roller bearing supports the external load (output flange).
Check the maximum load, moment load, life of the bearing and static safety coefficient to maximize performance.

Checking procedure

(1) Checking the maximum load moment load (Mmax)

Obtain the maximum load moment load (Mmax). ●●▶ Maximum load moment load (Mmax) ≤ Permissible moment (Mc)

(2) Checking the life

Obtain the average radial load (F_{rav}) and the average axial load (F_{aav}). ●●▶ Obtain the radial load coefficient (X) and the axial load coefficient (Y). ●●▶ Calculate the life and check it.

(3) Checking the static safety coefficient

Obtain the static equivalent radial load coefficient (P_o). ●●▶ Check the static safety coefficient. (f_s)

Specification of output bearing

HPGP/HPG Series Table 129-1, -2 and -3 indicate the specifications for gearhead, right angle and input shaft unit, and cross roller bearing.

Table 129-1

Size	Pitch circle	Offset amount	Basic rated load				Allowable moment load Mc ^{*3}		Moment stiffness Km ^{*4}	
	dp	R	Basic dynamic load rating C ^{*1}		Basic static load rating Co ^{*2}		Nm	Kgf·m	x10 ⁴ Nm/rad	Kgf·m/ arc min
	m	m	N	kgf	N	kgf				
11	0.0275	0.006	3116	318	4087	417	9.50	0.97	0.88	0.26
14	0.0405	0.011	5110	521	7060	720	32.3	3.30	3.0	0.90
20	0.064	0.0115	10600	1082	17300	1765	183	18.7	16.8	5.0
32	0.085	0.014	20500	2092	32800	3347	452	46.1	42.1	12.5
50	0.123	0.019	41600	4245	76000	7755	1076	110	100	29.7
65	0.170	0.023	90600	9245	148000	15102	3900	398	364	108

Table 129-2

Size	Reduction ratio	Allowable radial load ^{*5}		Allowable axial load ^{*5}	
		N	N	N	N
11	5	280	430		
	(9)	340	510		
	21	440	660		
	37	520	780		
	45	550	830		
14	(3)	400	600		
	5	470	700		
	11	600	890		
	15	650	980		
	21	720	1080		
	33	830	1240		
20	45	910	1360		
	(3)	840	1250		
	5	980	1460		
	11	1240	1850		
	15	1360	2030		
	21	1510	2250		
	33	1729	2580		
45	1890	2830			

* The ratio specified in parentheses is for the HPG Series.

Table 129-3

Size	Reduction ratio	Allowable radial load ^{*5}		Allowable axial load ^{*5}	
		N	N	N	N
32	(3)	1630	2430		
	5	1900	2830		
	11	2410	3590		
	15	2640	3940		
	21	2920	4360		
	33	3340	4990		
50	45	3670	5480		
	(3)	3700	5570		
	5	4350	6490		
	11	5500	8220		
	15	6050	9030		
	21	6690	9980		
	33	7660	11400		
65	45	8400	12500		
	4	8860	13200		
	5	9470	14100		
	12	12300	18300		
	15	13100	19600		
	20	14300	21400		
	25	15300	22900		
	(40)	17600	26300		
	(50)	18900	28200		

* The ratio specified in parentheses is for the HPG Series.

- *1 The basic dynamic load rating means a certain static radial load so that the basic dynamic rated life of the roller bearing is a million rotations.
- *2 The basic static load rating means a static load that gives a certain level of contact stress (4kN/mm²) in the center of the contact area between rolling element receiving the maximum load and orbit.
- *3 The allowable moment load is a maximum moment load applied to the bearing. Within the allowable range, basic performance is maintained and the bearing is operable. Check the bearing life based on the calculations shown on the next page.
- *4 The value of the moment stiffness is the average value.
- *5 The allowable radial load and allowable axial load are the values that satisfy the life of a speed reducer when a pure radial load or an axial load applies to the main bearing. (L_r + R = 0 mm for radial load and L_a = 0 mm for axial load) If a compound load applies, refer to the calculations shown on the next page.

Sold & Serviced By:
ELECTROMATE

Toll Free Phone (877) SERV098
Toll Free Fax (877) SERV099
www.electromate.com
sales@electromate.com

How to calculate the maximum load moment load

- HPGP
- HPG
- CSG-GH
- CSF-GH
- HPF

Maximum load moment load (M_{max}) is obtained as follows. Make sure that $M_{max} \leq M_c$.

Formula 131-1

$$M_{max} = Fr_{max}(L_r + R) + Fa_{max} L_a$$

Fr_{max}	Max. radial load	N (kgf)	See Fig. 131-1.
Fa_{max}	Max. axial load	N (kgf)	See Fig. 131-1.
L_r, L_a	—	m	See Fig. 131-1.
R	Offset amount	m	See Fig. 131-1. See "Specification of main bearing" of each series

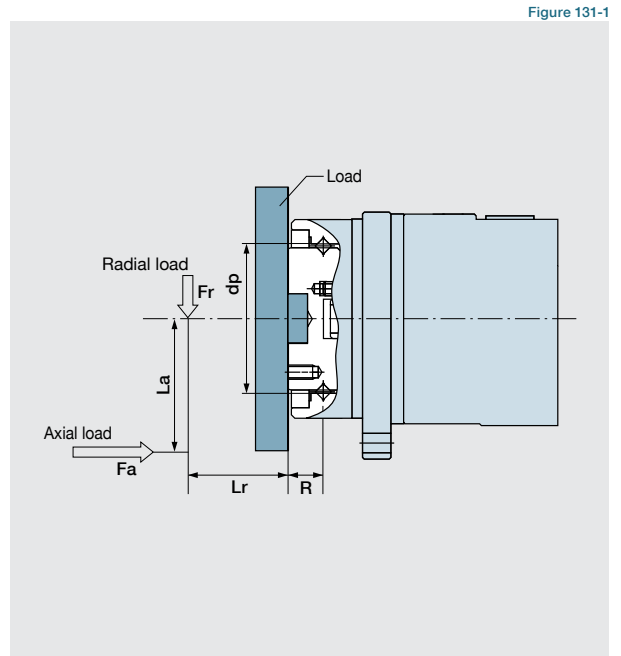

How to calculate the radial load coefficient and the axial load coefficient

- HPGP
- HPG
- CSG-GH
- CSF-GH
- HPF

The radial load coefficient (X) and the axial load coefficient (Y)

Formula 131-2

Formula	X	Y
$\frac{Fa_{av}}{Fr_{av} + 2(Fr_{av}(L_r + R) + Fa_{av} \cdot L_a) / dp} \leq 1.5$	1	0.45
$\frac{Fa_{av}}{Fr_{av} + 2(Fr_{av}(L_r + R) + Fa_{av} \cdot L_a) / dp} > 1.5$	0.67	0.67

Fr_{av}	Average radial load	N (kgf)	See "How to obtain the average load."
Fa_{av}	Average axial load	N (kgf)	See "How to obtain the average load."
L_r, L_a	—	m	See Fig. 131-1.
R	Offset amount	m	See Fig. 131-1. See "Output Shaft Bearing Specifications" of each series.
dp	Circular pitch of roller	m	See Fig. 131-1. See "Output Shaft Bearing Specifications" of each series.

How to calculate the average load (Average radial load, average axial load, average output rotational frequency)

- HPGP
- HPG
- CSG-GH
- CSF-GH
- HPF

If the radial load and the axial load fluctuate, they should be converted into the average load to check the life of the cross roller bearing.

How to obtain the average radial load (Fr_{av}) Formula 131-3

$$Fr_{av} = \sqrt[10/3]{\frac{n_1 t_1 (|Fr_1|)^{10/3} + n_2 t_2 (|Fr_2|)^{10/3} + \dots + n_n t_n (|Fr_n|)^{10/3}}{n_1 t_1 + n_2 t_2 + \dots + n_n t_n}}$$

Note that the maximum axial load within the t_1 section is Fr_1 and the maximum axial load within the t_3 section is Fr_3 .

How to obtain the average axial load (Fa_{av}) Formula 131-4

$$Fa_{av} = \sqrt[10/3]{\frac{n_1 t_1 (|Fa_1|)^{10/3} + n_2 t_2 (|Fa_2|)^{10/3} + \dots + n_n t_n (|Fa_n|)^{10/3}}{n_1 t_1 + n_2 t_2 + \dots + n_n t_n}}$$

Note that the maximum axial load within the t_1 section is Fr_1 and the maximum axial load within the t_3 section is Fr_3 .

How to obtain the average output rotational frequency (N_{av}) Formula 131-5

$$N_{av} = \frac{n_1 t_1 + n_2 t_2 + \dots + n_n t_n}{t_1 + t_2 + \dots + t_n}$$

Sold & Serviced By:

How to calculate the life HPGP HPG CSG-GH CSF-GH HPF

Calculate the life of the cross roller bearing using Formula 132-1. You can obtain the dynamic equivalent radial load (P_c) using Formula 132-2.

Formula 132-1

$$L_{10} = \frac{10^6}{60 \times N_{av}} \times \left(\frac{C}{f_w \cdot P_c} \right)^{10/3}$$

L₁₀	Life	hour	—
N_{av}	Ave. output speed	rpm	See "How to calculate the ave. load."
C	Basic dynamic rated load	N (kgf)	See "Output Bearing Specs."
P_c	Dynamic equi. radial load	N (kgf)	See Formula 132-2.
f_w	Load coefficient	—	See Table 132-1.

Formula 132-2

$$P_c = X \cdot \left(Fr_{av} + \frac{2(Fr_{av}(L_r + R) + Fa_{av} \cdot La)}{dp} \right) + Y \cdot Fa_{av}$$

Fr_{av}	Average radial load	N (kgf)	See "How to calculate the ave. load."
Fa_{av}	Average axial load	N (kgf)	
dp	Circular pitch of roller	m	See "Output Bearing Specs."
X	Radial load coefficient	—	See "How to calculate the radial load coefficient and the axial load coefficient."
Y	Axial load coefficient	—	
L_r, La	—	m	See Figure 131-1. See "External load influence diagram."
R	Offset amount	m	See Figure 131-1. See "External load influence diagram" and "Output Bearing Specs" of each series.

Load coefficient Table 132-1

Load status	f _w
During smooth operation without impact or vibration	1 to 1.2
During normal operation	1.2 to 1.5
During operation with impact or vibration	1.5 to 3

How to calculate the life during oscillating movement HPGP HPG CSG-GH CSF-GH HPF

Calculate the life of the cross roller bearing during oscillating movement by Formula 132-3.

Formula 132-3

$$L_{oc} = \frac{10^6}{60 \times n_1} \times \frac{90}{\theta} \times \left(\frac{C}{f_w \cdot P_c} \right)^{10/3}$$

L_{oc}	Rated life under oscillating movement	hour	—
n₁	No. of reciprocating oscillation per min.	cpm	—
C	Basic dynamic rated load	N (kgf)	See "Output Bearing Specs."
P_c	Dynamic equivalent radial load	N (kgf)	See Formula 132-2.
f_w	Load coefficient	—	See Table 132-1.
θ	Oscillating angle /2	Deg.	See Figure 132-1.

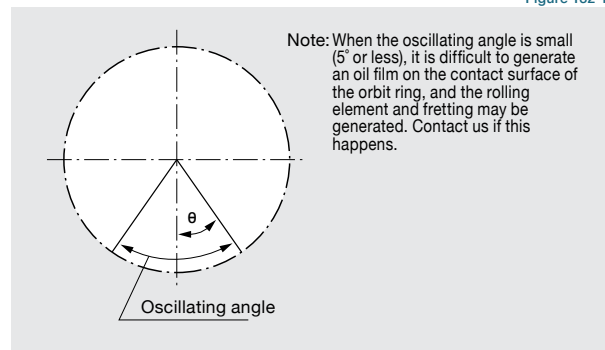

Note When it is used for a long time while the rotation speed of the output shaft is in the ultra-low operation range (0.02rpm or less), the lubrication of the bearing becomes insufficient, resulting in deterioration of the bearing or increased load in the driving side. When using it in the ultra-low operation range, contact us.

How to calculate the static safety coefficient HPGP HPG CSG-GH CSF-GH HPF

In general, the basic static rated load (C_o) is considered to be the permissible limit of the static equivalent load. However, obtain the limit based on the operating and required conditions. Calculate the static safety coefficient (f_s) of the cross roller bearing using Formula 132-4.

General values under the operating condition are shown in Table 132-2. You can calculate the static equivalent radial load (P_o) using Formula 132-5.

Formula 132-4

$$f_s = \frac{C_o}{P_o}$$

C_o	Basic static rated load	N (kgf)	See "Output Bearing Specs."
P_o	Static equivalent radial load	N (kgf)	See Formula 132-5.

Formula 132-5

$$P_o = Fr_{max} + \frac{2M_{max}}{dp} + 0.44Fa_{max}$$

Fr_{max}	Max. radial load	N (kgf)	
Fa_{max}	Max. axial load	N (kgf)	See "How to calculate the max. load moment load."
M_{max}	Max. load moment load	Nm (kgfm)	
dp	Circular pitch of roller	m	See "Output Bearing Specs" of each series.

Static safety coefficient Table 132-2

Load status	f _s
When high rotation precision is required	≧ 3
When impact or vibration is expected	≧ 2
Under normal operating condition	≧ 1.5

Input Bearing Specifications and Checking Procedure

Check the maximum load and life of the bearing on the input side if the reducer is an HPG input shaft unit or an HPF hollow shaft unit.

Checking procedure HPG HPF

(1) Checking maximum load

Calculate:

Maximum load moment load (Mi_{max})
Maximum load axial load (Fai_{max})
Maximum load radial load (Fri_{max})



Maximum load moment load (Mi_{max}) \leq Permissible moment load (Mc)
Maximum load axial load (Fai_{max}) \leq Permissible axial load (Fac)
Maximum load radial load (Fri_{max}) \leq Permissible radial load (Frc)

(2) Checking the life

Calculate:

Average moment load (Mi_{av})
Average axial load (Fai_{av})
Average input speed (Ni_{av})



Calculate the life and check it.

Specification of input shaft bearing

The specification of the input side main bearing of the input shaft unit is shown below.

Specification of input shaft bearing HPG

Table 133-1

Size	Basic rated load			
	Basic dynamic rated load Cr		Basic static rated load Cor	
	N	kgf	N	kgf
11	2700	275	1270	129
14	5800	590	3150	320
20	9700	990	5600	570
32	22500	2300	14800	1510
50	35500	3600	25100	2560
65	51000	5200	39500	4050

Table 133-2

Size	Allowable moment load Mc		Allowable axial load Fac^{*1}		Allowable radial load Frc^{*2}	
	Nm	kgfm	N	kgf	N	kgf
11	0.16	0.016	245	25	20.6	2.1
14	6.3	0.64	657	67	500	51
20	13.5	1.38	1206	123	902	92
32	44.4	4.53	3285	335	1970	201
50	96.9	9.88	5540	565	3226	329
65	210	21.4	8600	878	5267	537

Specification of input shaft bearing HPF

Table 133-3

Size	Basic rated load			
	Basic dynamic rated load Cr		Basic static rated load Cor	
	N	kgf	N	kgf
25	14500	1480	10100	1030
32	29700	3030	20100	2050

Table 133-4

Size	Allowable moment load Mc		Allowable axial load Fac^{*1}		Allowable radial load Frc^{*3}	
	Nm	kgfm	N	kgf	N	kgf
25	10	1.02	1538	157	522	53.2
32	19	1.93	3263	333	966	98.5

(Note: Table 133-2 and 133-4)

*1 The allowable axial load is the tolerance of an axial load applied to the shaft center.

*2 The allowable radial load of HPG series is the tolerance of a radial load applied to the shaft length center.

*3 The allowable radial load of HPG series is the tolerance of a radial load applied to the point of 20 mm from the shaft edge (input flange edge).

Calculating maximum load moment load to input shaft

The maximum load moment load ($M_{i max}$) is calculated as follows. Check that the following formulas are established in all circumstances:

Formula 134-1

$$M_{i max} = F_{ri max} \cdot L_{ri} + F_{ai max} \cdot L_{ai}$$

$F_{ri max}$	Max. radial load	N (kgf)	See Fig. 134-1.
$F_{ai max}$	Max. axial load	N (kgf)	See Fig. 134-1.
L_{ri}, L_{ai}	-----	m	See Fig. 134-1.

$$M_{i max} \leq M_c \text{ (Permissible moment load)}$$

$$F_{ai max} \leq F_{ac} \text{ (Permissible axial load)}$$

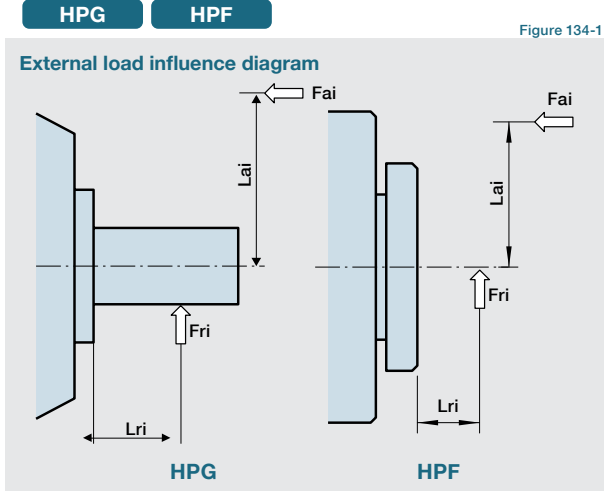

How to calculate average load (Average moment load, average axial load, average input rotational frequency)

If moment load and axial load fluctuate, they should be converted into the average load to check the life of the bearing.

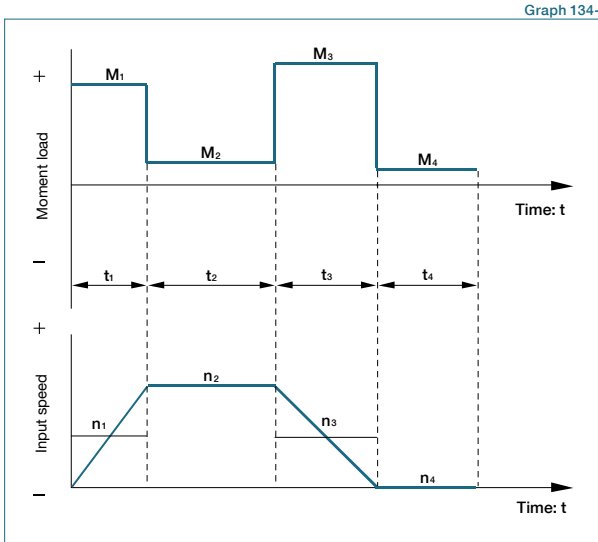

How to calculate the average moment load ($M_{i av}$)

Formula 134-2

$$M_{i av} = \sqrt[3]{\frac{n_1 t_1 (|M_{i1}|)^3 + n_2 t_2 (|M_{i2}|)^3 + \dots + n_n t_n (|M_{in}|)^3}{n_1 t_1 + n_2 t_2 + \dots + n_n t_n}}$$

How to calculate the average axial load ($F_{ai av}$)

Formula 134-3

$$F_{ai av} = \sqrt[3]{\frac{n_1 t_1 (|F_{ai1}|)^3 + n_2 t_2 (|F_{ai2}|)^3 + \dots + n_n t_n (|F_{ain}|)^3}{n_1 t_1 + n_2 t_2 + \dots + n_n t_n}}$$

How to calculate the average output rotational frequency ($N_{i av}$)

Formula 134-4

$$N_{i av} = \frac{n_1 t_1 + n_2 t_2 + \dots + n_n t_n}{t_1 + t_2 + \dots + t_n}$$

Calculating life of input side bearing

Calculate the bearing life according to Calculation Formula 132-5 and check the life.

Formula 134-5

$$L_{10} = \frac{10^6}{60 \times N_{i av}} \times \left(\frac{C_r}{P_{ci}} \right)^3$$

L_{10}	Life	Hour	—
$N_{i av}$	Average input rotational speed	rpm	See Formula 134-4
C_r	Basic dynamic rated load	N (kgf)	See Table 133-1 and -3
P_{ci}	Dynamic equivalent radial load	N	See Table 134-1 and -2

Dynamic equivalent radial load

HPG

Table 134-1

Size	P_{ci}
11	$0.444 \times M_{i av} + 1.426 \times F_{ai av}$
14	$0.137 \times M_{i av} + 1.232 \times F_{ai av}$
20	$0.109 \times M_{i av} + 1.232 \times F_{ai av}$
32	$0.071 \times M_{i av} + 1.232 \times F_{ai av}$
50	$0.053 \times M_{i av} + 1.232 \times F_{ai av}$
65	$0.041 \times M_{i av} + 1.232 \times F_{ai av}$

Dynamic equivalent radial load

HPF

Table 134-2

Size	P_{ci}
25	$121 \times M_{i av} + 2.7 \times F_{ai av}$
32	$106 \times M_{i av} + 2.7 \times F_{ai av}$

$M_{i av}$ Average moment load Nm (kgfm) See Formula 134-2
 $F_{ai av}$ Average axial load N (kgf) See Formula 134-3