

# HarmonicPlanetary® HPN Value Series

## Size

11, 14, 20, 32, 40

5

Sizes

## Peak Torque

9Nm ~ 752Nm

## Reduction Ratio

Single stage: 3:1 to 10:1, Two stage: 13:1 to 31:1

## Backlash

Single stage: < 5 arc-min, Two stage: < 7 arc-min

## High Efficiency

Up to 97%

## Output Bearing

A radial ball bearing is integrated with the output flange to provide high moment stiffness, high load capacity and precise positioning accuracy.

## Easy mounting to a wide variety of servomotors

Quick Connect™ coupling

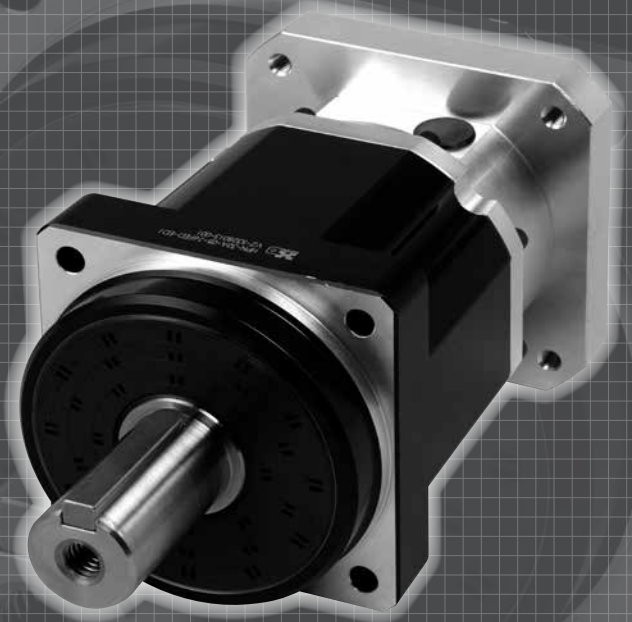

# CONTENTS

Rating, Performance Table .....	2
Outline Dimensions .....	3-7
Product Sizing & Selection .....	8-9

## HPN - 14 | A - 05 - J6 | Motor Model Number

Model Name	Size	Design Revision	Reduction Ratio	Output Configuration	Input Configuration
HarmonicPlanetary® HPN High Torque	11	A	4, 5, 7, 10, 16, 20, 30	J6: With a key and center tapped hole J8: Smooth shaft with center tapped hole	This code represents the motor mounting configuration. Please contact us for a unique part number based on the motor you are using.
	14		3, 4, 5, 7, 1 0, 13, 21, 31		
	20				
	32				
	40				

## Gearhead Construction

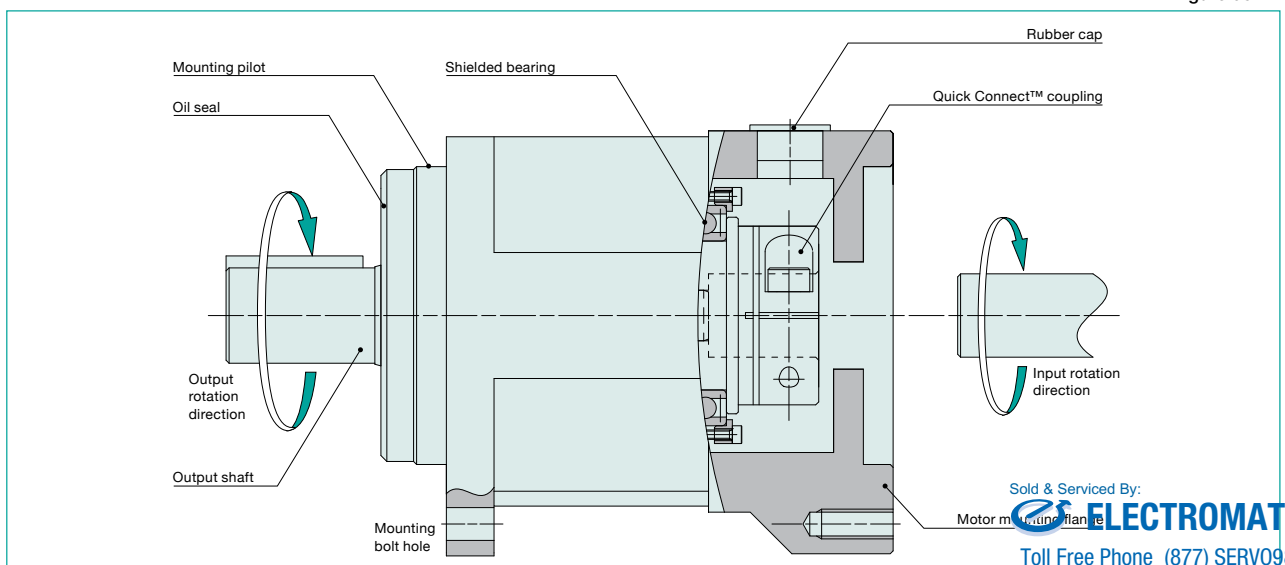

Figure 054-1

Sold & Serviced By:  
**ELECTROMATE**

Toll Free Phone (877) SERV098

Toll Free Fax (877) SERV099

www.electromate.com

sales@electromate.com

## Rating Table

Please contact our sales office if you have any questions about our specifications or comparison with another company's products.

Table 055-1

Size	Number of Stages	Ratio	Rated Torque *1	Limit for Repeated Peak Torque *2	Limit for Momentary Peak Torque *3	Max. Average Rated Input Speed*4	Max. Input Speed (grease) *5	Allowable Radial Load *6	Allowable Axial Load *7
			Nm	Nm	Nm	rpm	rpm	rpm	rpm
11	1	4	14	14	40	3,000	10,000	240	280
		5	14	16	40			260	320
		7	11	11	40			280	360
		10	9	9	40			320	420
	2	16	18	24	40			360	460
		20	22	24	40			400	560
14	1	30	25	26	40	480	640		
		3	22	25	89	380	340		
		4	28	50	110	420	380		
		5	29	50	107	450	410		
		7	30	37	100	510	480		
		10	18	18	79	570	580		
	2	13	30	43	106	630	630		
		21	30	50	99	740	780		
		31	30	38	101	840	900		
		3	51	74	226	830	900		
20	1	4	80	130	256	920	1,100		
		5	80	149	256	1,000	1,200		
		7	80	113	256	1,100	1,400		
		10	54	54	216	1,230	1,600		
	2	13	80	130	256	1,350	1,850		
		21	80	147	256	1,600	2,100		
		31	80	113	256	1,800	2,200		
		3	153	254	625	1,800	2,000		
32	1	4	198	376	625	1,900	2,300		
		5	200	376	625	2,000	2,500		
		7	200	376	625	2,300	2,900		
		10	185	185	625	2,600	3,200		
	2	13	200	376	625	2,900	3,600		
		21	200	376	625	3,400	3,800		
		31	200	376	625	3,900	3,800		
		3	440	752	1,137	2,800	2,700		
40	1	4	460	752	1,265	3,100	3,000		
		5	480	752	1,265	3,400	3,300		
		7	510	752	829	3,800	3,800		
		10	480	509	829	4,200	4,200		
	2	13	530	752	823	4,500	4,500		
		21	620	752	1,029	5,000	5,000		
		31	700	752	1,097	5,500	5,400		

\*1: Rated torque is based on L50 life of 20,000 hours at rated input speed.

\*2: The limit for torque during start and stop cycles.

\*3: The limit for torque during emergency stops or from external shock loads. Always operate below this value. Calculate the number of permissible events to ensure it meets required operating conditions.

\*4: Maximum average input speed is limited by heat generation in the speed reducer assuming a continuous operating speed or the average input speed of a motion profile. The actual limit for average input speed depends on the operating environment.

\*5: Maximum instantaneous input speed.

\*6: The load at which the output bearing will have 20,000 hour life at the rated input speed. (Axial load = 0 and radial load point is in the center of the output shaft.)

\*7: The load at which the output bearing life will be 20,000 hours at the rated input speed. (Radial load = 0 and axial load point is in the center of the output shaft.)

## Performance

Table 055-2

Size	Number of Stages	Reduction Ratio	Backlash	Noise*1	Torsional Stiffness	
			arc min	dB	kgfm/arc-min	X100N·m/rad
11	1	4	< 5	< 56*2	0.060	20
		5				
		7				
		10				
	2	16	< 7			
		20				
14	1	30	< 5	< 58*2	0.27	93
		3*2				
		4				
		5				
		7				
		10				
	2	13	< 7			
		21				
		31				
		3				
1	4					
	5					
	7					
	10					
2	13	< 7				
	21					
	31					

Table 055-3

Size	Number of Stages	Reduction Ratio	Backlash	Noise*1	Torsional Stiffness	
			arc min	dB	kgfm/arc-min	X100N·m/rad
32	1	3*2	< 5	< 63*2	2.8	940
		4				
		5				
		7				
	2	10	< 7			
		13				
40	1	31	< 5	< 65*2	4.2	1430
		3*2				
		4				
		5				
	2	7	< 7			
		10				
		13				
		21				
31						

\*1: The above noise values are reference values.

\*2: Contact us for noise values for sizes with a reduction ratio of 3.

Sold & Serviced By:

**ELECTROMATE**

Toll Free Phone (877) SERV098

Toll Free Fax (877) SERV099

Harmonic Planetary® & Harmonic Drive® Gearheads **2**  
sales@electromate.com

## HPN-11A Outline Dimensions

Figure 056-1  
(Unit: mm)

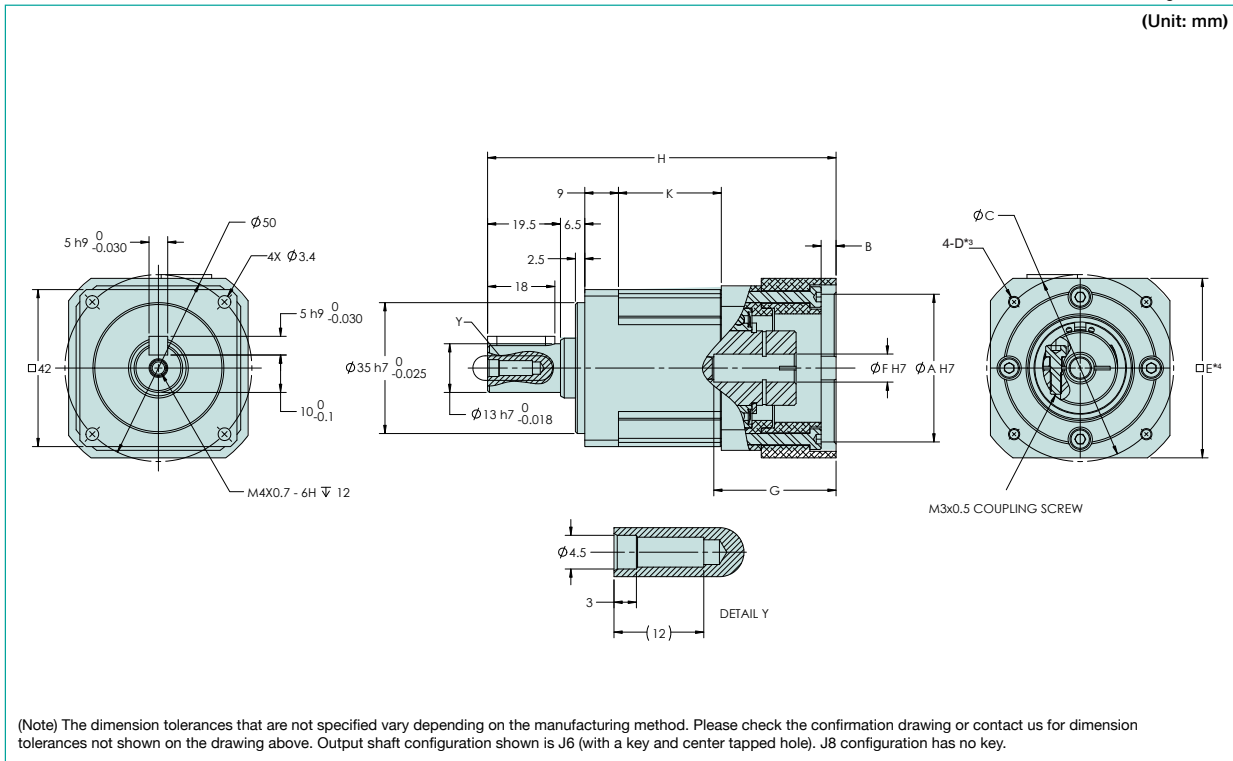

## Dimension Table

(Unit: mm) Table 056-1

	A (H7)		B	C		F (H7)		G		H*1	K	Mass(kg)*2
	Min.	Max.*4	Max.	Min.	Max.*4	Min.	Max.	Min.	Max.			
Single Stage	30	42	3	35	49	4.8	9	15	26	86.5	27.5	0.44
Two Stage										106	47	0.57

Refer to the confirmation drawing for detailed dimensions. Dimensions of typical products are shown. Please contact us for other mounting options if the configurations shown above are not suitable for your particular motor.

\*1 May vary depending on motor interface dimensions.

\*2 The mass will vary slightly depending on the ratio and on the inside diameter of the input shaft coupling.

\*3 Tapped hole for motor mounting screw.

\*4 E dimension is dependent on motor selection.

## Moment of Inertia

(10<sup>-4</sup> kgm<sup>2</sup>) Table 056-2

HPN 11A	Ratio	4	5	7	10	16	20	30
	Coupling	1	0.042	0.04	0.038	0.037	0.04	0.04

Sold & Serviced By:

**ELECTROMATE**

Toll Free Phone (877) SERV098

Toll Free Fax (877) SERV099

www.electromate.com

sales@electromate.com

# HPN-14A Outline Dimensions

Figure 057-1  
(Unit: mm)

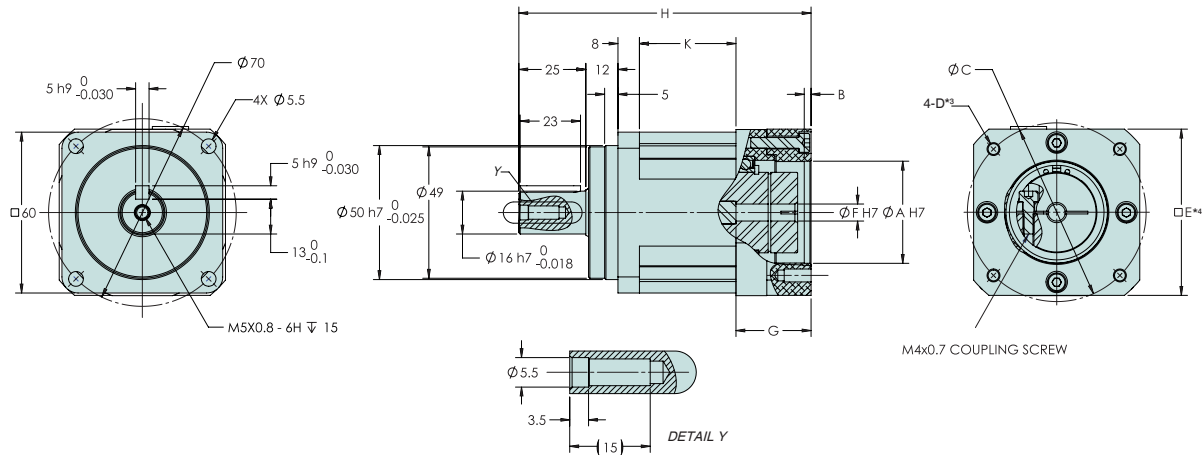

(Note) The dimension tolerances that are not specified vary depending on the manufacturing method. Please check the confirmation drawing or contact us for dimension tolerances not shown on the drawing above. Output shaft configuration shown is J6 (with a key and center tapped hole). J8 configuration has no key.

## Dimension Table

(Unit: mm) Table 057-1

	Flange	Coupling	A (H7)		B	C		F (H7)		G		H <sup>1</sup>	K	Mass(kg) <sup>*2</sup>
			Min.	Max. <sup>*1</sup>	Max.	Min.	Max. <sup>*1</sup>	Min.	Max.	Min.	Max.			
Single Stage	1	1	30	39	5	35	49	4.8	8	17	25	107	36	0.95
Two Stage			132	61	1.3									
Single Stage	2	2	50	59	5	56	74	4.8	14	24	31	112	36	1.2
Two Stage			137	61	1.6									

Refer to the confirmation drawing for detailed dimensions. Dimensions of typical products are shown. Please contact us for other mounting options if the configurations shown above are not suitable for your particular motor.

- \*1 May vary depending on motor interface dimensions.
- \*2 The mass will vary slightly depending on the ratio and on the inside diameter of the input shaft coupling.
- \*3 Tapped hole for motor mounting screw.
- \*4 E dimension is dependent on motor selection.

## Moment of Inertia

(10<sup>-4</sup> kgm<sup>2</sup>) Table 057-2

HPN 14A	Coupling	Ratio	3	4	5	7	10	13	21	31
	1		0.24	0.21	0.2	0.19	0.19	0.2	0.2	-
	2		0.124	0.096	0.083	0.072	0.066	0.049	0.043	0.041

Sold & Serviced By:

**ELECTROMATE**

Toll Free Phone (877) SERV098

Toll Free Fax (877) SERV099

Harmonic Planetary<sup>®</sup> & Harmonic Direct Gearheads  
sales@electromate.com

## HPN-20A Outline Dimensions

Figure 058-1

(Unit: mm)

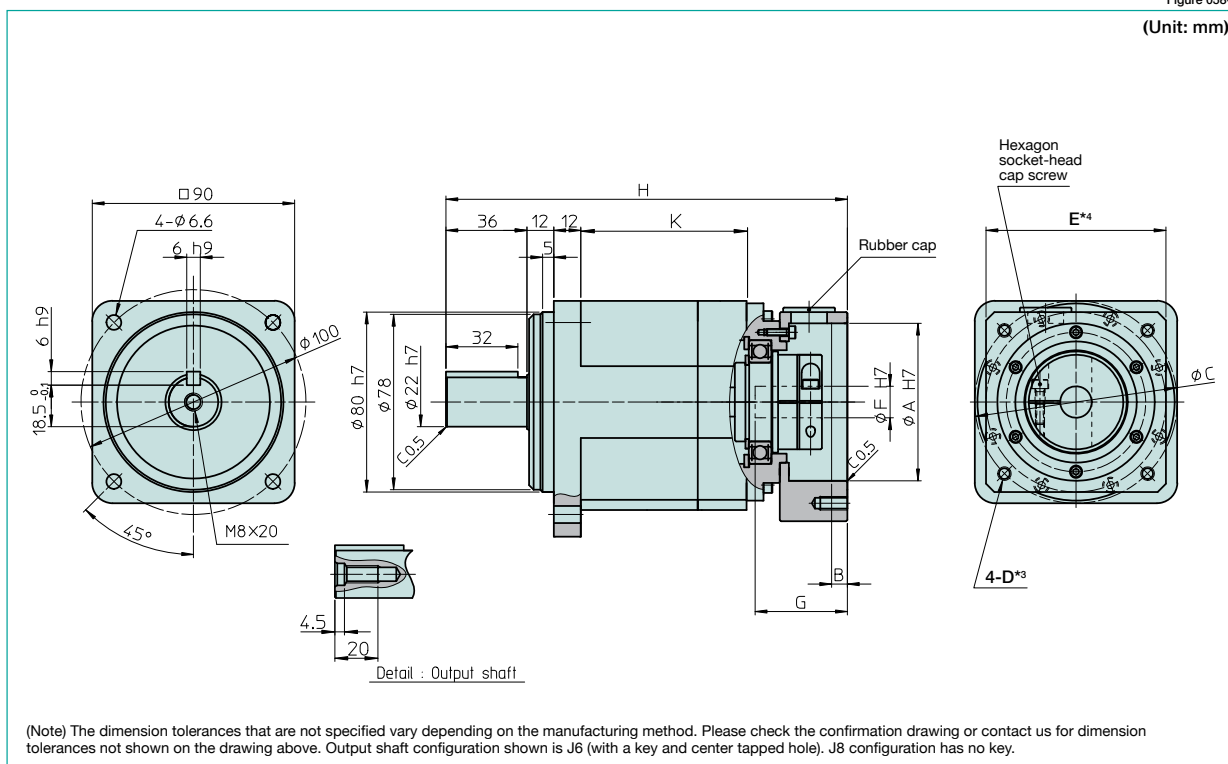

(Note) The dimension tolerances that are not specified vary depending on the manufacturing method. Please check the confirmation drawing or contact us for dimension tolerances not shown on the drawing above. Output shaft configuration shown is J6 (with a key and center tapped hole). J8 configuration has no key.

## Dimension Table

(Unit: mm) Table 058-1

	Flange	Coupling	A (H7)		B	C		F (H7)		G <sup>1</sup>		H <sup>1</sup>	K	Mass(kg) <sup>2</sup>
			Min.	Max. <sup>1</sup>		Min.	Max. <sup>1</sup>	Min.	Max.	Min.	Max.			
Single Stage	1	1	38	85	7	58	110	8	25	21	42	151.8	52	3
Two Stage			19.5	36						173.5	73.7			
Single Stage	2	2	50	125	7	58	155	4.8	25	45	66	169.8	52	5
Two Stage			43.5	60						191.5	73.7			

Refer to the confirmation drawing for detailed dimensions. Dimensions of typical products are shown. Please contact us for other mounting options if the configurations shown above are not suitable for your particular motor.

<sup>1</sup> May vary depending on motor interface dimensions.

<sup>2</sup> The mass will vary slightly depending on the ratio and on the inside diameter of the input shaft coupling.

<sup>3</sup> Tapped hole for motor mounting screw.

<sup>4</sup> E dimension is dependent on motor selection.

## Moment of Inertia

(10<sup>-4</sup> kgm<sup>2</sup>) Table 058-2

HPN 20A	Ratio	3	4	5	7	10	13	21	31
	Coupling								
	1	1.2	1	1	0.9	0.87	0.9	0.88	0.87

Sold & Serviced By:

**ELECTROMATE**

Toll Free Phone (877) SERV098

Toll Free Fax (877) SERV099

www.electromate.com

sales@electromate.com

# HPN-32A Outline Dimensions

Figure 059-1  
(Unit: mm)

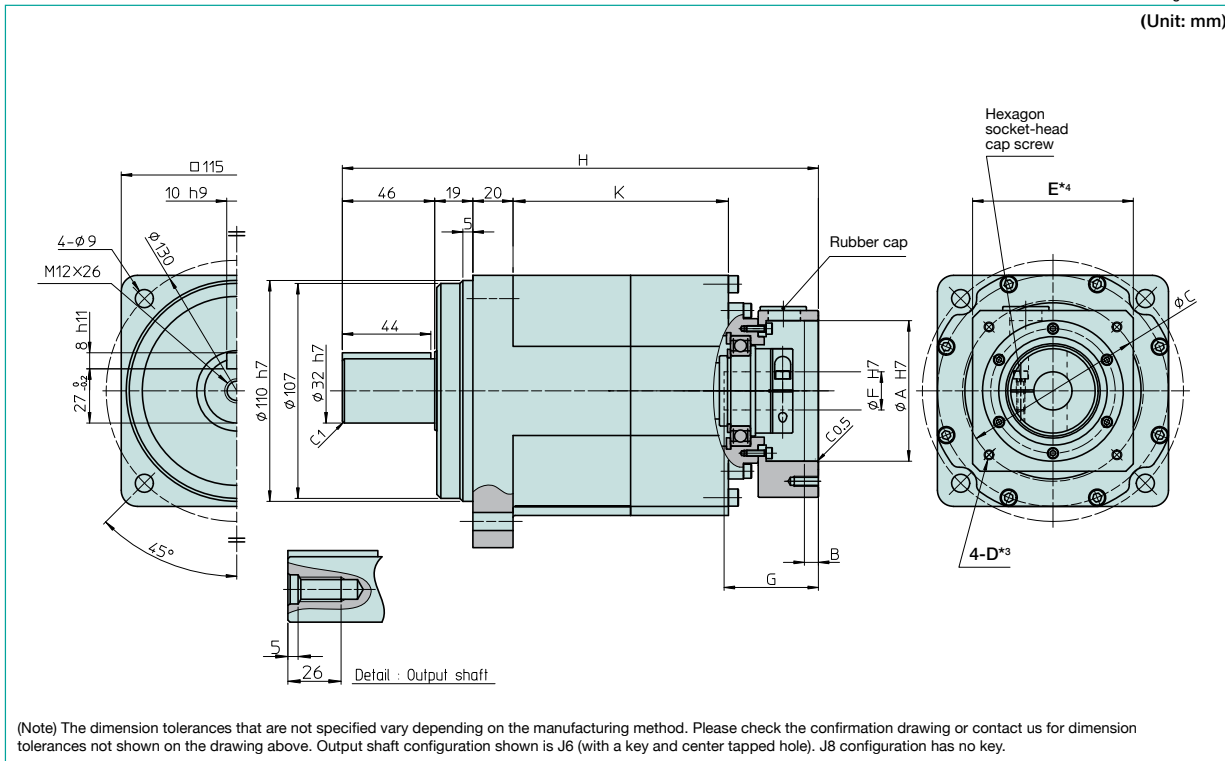

(Note) The dimension tolerances that are not specified vary depending on the manufacturing method. Please check the confirmation drawing or contact us for dimension tolerances not shown on the drawing above. Output shaft configuration shown is J6 (with a key and center tapped hole). J8 configuration has no key.

## Dimension Table

(Unit: mm) Table 059-1

	Flange	Coupling	A (H7)		B	C		F (H7)		G <sup>1</sup>		H <sup>1</sup>	K	Mass(kg) <sup>2</sup>
			Min.	Max. <sup>1</sup>		Min.	Max. <sup>1</sup>	Min.	Max.	Min.	Max.			
Single Stage	1	1	50	85	7	77	110	15.5	25	20	46	195	58.5	6.6
	2	2	70	125	7	77	155	15.5	28	47	69	212.5	58.5	7.7
	3	3	70	215	6.5	77	260	21.5	41	47	85	233.5	58.5	9.3
Two Stage	4	4	50	85	7	58	110	8	25	21	42	232	107.2	7.9
	5	4	50	125	7	58	155	8	25	44	65	255	107.2	9.1

Refer to the confirmation drawing for detailed dimensions. Dimensions of typical products are shown. Please contact us for other mounting options if the configurations shown above are not suitable for your particular motor.

- <sup>1</sup> May vary depending on motor interface dimensions.
- <sup>2</sup> The mass will vary slightly depending on the ratio and on the inside diameter of the input shaft coupling.
- <sup>3</sup> Tapped hole for motor mounting screw.
- <sup>4</sup> E dimension is dependent on motor selection.

## Moment of Inertia

(10<sup>-4</sup> kgm<sup>2</sup>) Table 059-2

	Coupling	Ratio								
		3	4	5	7	10	13	21	31	
HPN 32A	1	2.3	1.7	1.5	1.3	1.2	-	-	-	
	2	5	3.8	3.3	2.9	2.7	-	-	-	
	3	7.5	6.2	5.7	5.3	5.3	-	-	-	
	4	-	-	-	-	-	1.3	1.1	1	

Sold & Serviced By:

**ELECTROMATE**

Toll Free Phone (877) SERV098

Toll Free Fax (877) SERV099

Harmonic Planetary<sup>®</sup> & Harmonic Drive<sup>®</sup> Gearheads  
sales@electromate.com

## HPN-40A Outline Dimensions

Figure 060-1  
(Unit: mm)

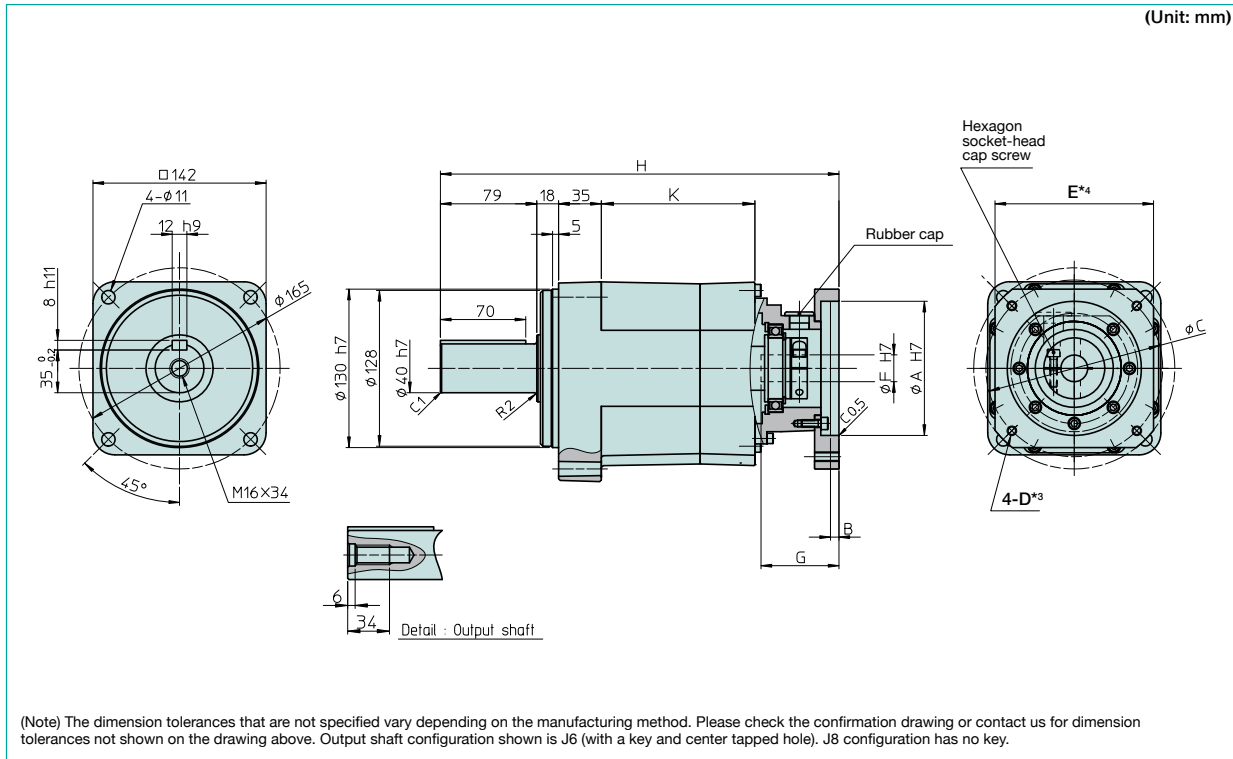

(Note) The dimension tolerances that are not specified vary depending on the manufacturing method. Please check the confirmation drawing or contact us for dimension tolerances not shown on the drawing above. Output shaft configuration shown is J6 (with a key and center tapped hole). J8 configuration has no key.

## Dimension Table

(Unit: mm) Table 060-1

	Flange	Coupling	A (H7)		B	C		F (H7)		G <sup>1</sup>		H <sup>1</sup>	K	Mass(kg) <sup>*2</sup>
			Min.	Max. <sup>*1</sup>	Max.	Min.	Max. <sup>*1</sup>	Min.	Max.	Min.	Max.			
Single Stage	1	1	70	215	6.5	78	260	15.5	41	34.5	72	295.5	81	17
	2	2	70	175	6.5	78	225	15.5	42	39	105	328.5	81	16
	3	3	70	125	7	78	155	15.5	24	47	77	282.5	81	13
Two Stage	4	4	70	125	7	78	155	15.5	28	47	69	309.5	126	17
	5	5	70	215	6.5	77	260	21.5	41	47	85	348	126	18

Refer to the confirmation drawing for detailed dimensions. Dimensions of typical products are shown. Please contact us for other mounting options if the configurations shown above are not suitable for your particular motor.

<sup>\*1</sup> May vary depending on motor interface dimensions.

<sup>\*2</sup> The mass will vary slightly depending on the ratio and on the inside diameter of the input shaft coupling.

<sup>\*3</sup> Tapped hole for motor mounting screw.

<sup>\*4</sup> E dimension is dependent on motor selection.

## Moment of Inertia

(10<sup>-4</sup> kgm<sup>2</sup>) Table 060-2

	Ratio Coupling	3	4	5	7	10	13	21	31
		HPN 40A	1	14	9.1	7.3	6.2	5.4	-
2	15		11	8.8	7.3	6.5	-	-	-
3	10.2		6.9	5.4	4.1	3.4	-	-	-
4	-		-	-	-	-	4.5	3.5	3.4
5	-		-	-	-	-	7	6	5.8

Sold & Serviced By:

**ELECTROMATE**

Toll Free Phone (877) SERV098

Toll Free Fax (877) SERV099

www.electromate.com

sales@electromate.com



## Product Sizing & Selection

To fully utilize the excellent performance of the HPN HarmonicPlanetary® gearheads, check your operating conditions and, using the flowchart, select the appropriate size gear for your application.

In general, a servo system rarely operates at a continuous load and speed. The input speed, load torque change and a comparatively large torque is applied during start and stop. Unexpected impact torques may also be applied.

Check your operating conditions against the following load torque pattern and select a suitable size based on the flowchart shown on the right. Also check the life and static safety coefficient of the cross roller bearing and input side main bearing (input shaft type only).

### Checking the load torque pattern

Review the load torque pattern. Check the specifications shown in the figure below.

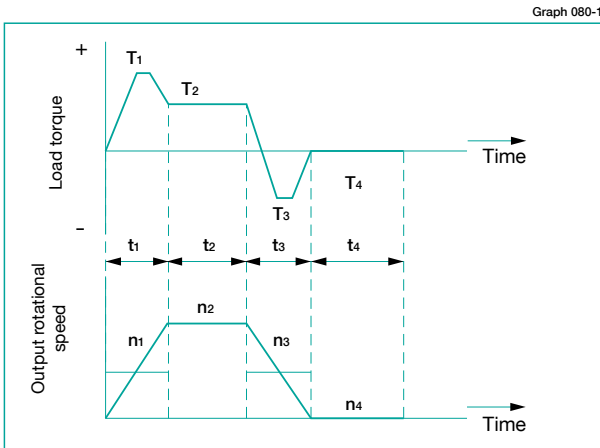

#### Obtain the value of each load torque pattern.

Load torque	T <sub>1</sub> to T <sub>n</sub> (Nm)
Time	t <sub>1</sub> to t <sub>n</sub> (sec)
Output rotational speed	n <sub>1</sub> to n <sub>n</sub> (rpm)

#### <Normal operation pattern>

Starting	T <sub>1</sub> , t <sub>1</sub> , n <sub>1</sub>
Steady operation	T <sub>2</sub> , t <sub>2</sub> , n <sub>2</sub>
Stopping (slowing)	T <sub>3</sub> , t <sub>3</sub> , n <sub>3</sub>
Idle	T <sub>4</sub> , t <sub>4</sub> , n <sub>4</sub>

#### <Maximum rotational speed>

Max. output rotational speed	$n_{o\ max} \geq n_1$ to $n_n$
Max. input rotational speed	$n_{i\ max} n_1 \times R$ to $n_n \times R$
(Restricted by motors)	R: Reduction ratio

#### <Impact torque>

When impact torque is applied T<sub>s</sub>

#### <Required life>

L<sub>50</sub> = L (hours)

### Flowchart for selecting a size

Please use the flowchart shown below for selecting a size. Operating conditions must not exceed the performance ratings.

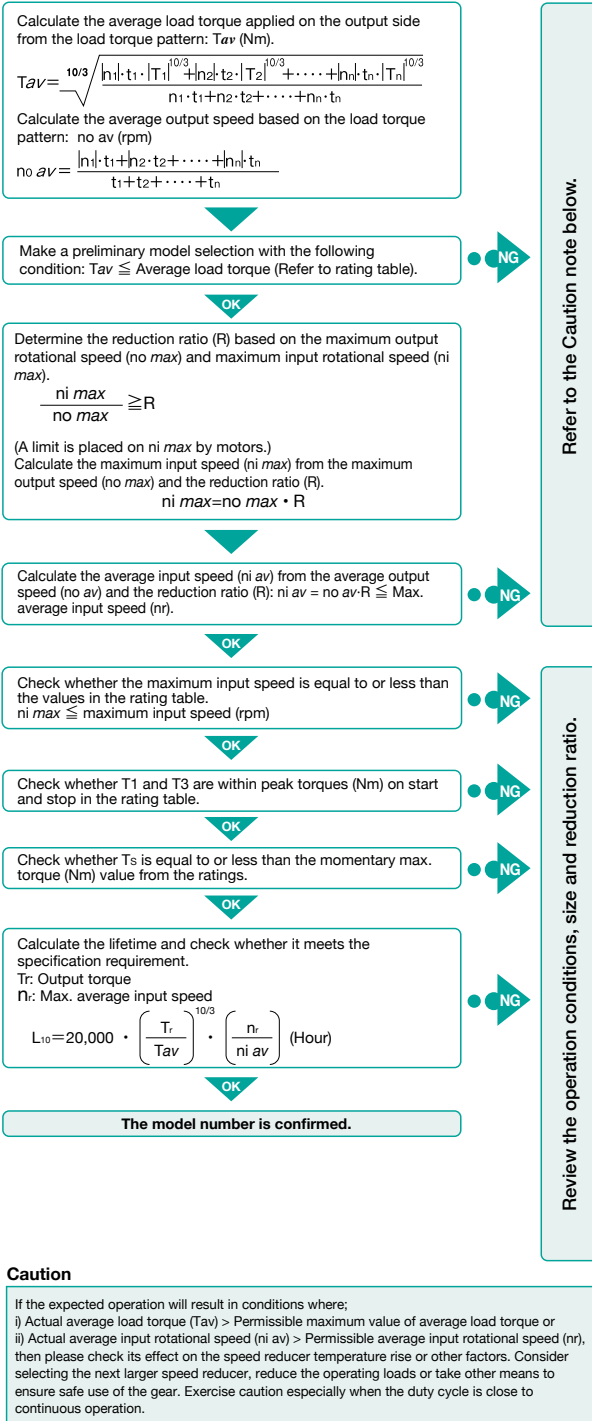

Sold & Serviced By:

**ELECTROMATE**

Toll Free Phone (877) SERV098  
Toll Free Fax (877) SERV099



## Example of model number Selection

### Value of each load torque pattern.

Load torque	$T_n$ (Nm)	<Maximum rotational speed>	
Time	$t_n$ (sec)	Max. output rotational speed	$n_{o\ max} = 120$ rpm
Output rotational speed	$n_n$ (rpm)	Max. input rotational speed	$n_{i\ max} = 5,000$ rpm (Restricted by motors)
<Normal operation pattern>			
Starting	$T_1 = 70$ Nm, $t_1 = 0.3$ sec, $n_1 = 60$ rpm	<Impact torque>	
Steady operation	$T_2 = 18$ Nm, $t_2 = 3$ sec, $n_2 = 120$ rpm	When impact torque is applied	$T_s = 180$ Nm
Stopping (slowing)	$T_3 = 35$ Nm, $t_3 = 0.4$ sec, $n_3 = 60$ rpm	<Required life>	
Idle	$T_4 = 0$ Nm, $t_4 = 5$ sec, $n_4 = 0$ rpm	$L_{50} = 30,000$ (hours)	

Calculate the average load torque applied to the output side based on the load torque pattern:  $T_{av}$  (Nm).

$$T_{av} = \sqrt[10/3]{\frac{|60\text{rpm}| \cdot 0.3\text{sec} \cdot |70\text{Nm}|^{10/3} + |120\text{rpm}| \cdot 3\text{sec} \cdot |18\text{Nm}|^{10/3} + |60\text{rpm}| \cdot 0.4\text{sec} \cdot |35\text{Nm}|^{10/3}}{|60\text{rpm}| \cdot 0.3\text{sec} + |120\text{rpm}| \cdot 3\text{sec} + |60\text{rpm}| \cdot 0.4\text{sec}}}$$

Calculate the average output speed based on the load torque pattern:  $n_{o\ av}$  (rpm)

$$n_{o\ av} = \frac{|60\text{rpm}| \cdot 0.3\text{sec} + |120\text{rpm}| \cdot 3\text{sec} + |60\text{rpm}| \cdot 0.4\text{sec} + |0\text{rpm}| \cdot 5\text{sec}}{0.3\text{sec} + 3\text{sec} + 0.4\text{sec} + 5\text{sec}}$$

Make a preliminary model selection with the following conditions.  $T_{av} = 30.2$  Nm  $\leq$  80 Nm. (HPN-20A-31 is tentatively selected based on the average load torque (see the rating table) of size 20 and reduction ratio of 31.)

OK

Determine a reduction ratio (R) from the maximum output speed ( $n_{o\ max}$ ) and maximum input speed ( $n_{i\ max}$ ).

$$\frac{5,000\ \text{rpm}}{120\ \text{rpm}} = 41.7 \geq 31$$

Calculate the maximum input speed ( $n_{i\ max}$ ) from the maximum output speed ( $n_{o\ max}$ ) and reduction ratio (R):  $n_{i\ max} = 120\ \text{rpm} \cdot 31 = 3,720\ \text{rpm}$

Calculate the average input speed ( $n_{i\ av}$ ) from the average output speed ( $n_{o\ av}$ ) and reduction ratio (R):  
 $n_{i\ av} = 46.2\ \text{rpm} \cdot 31 = 1,432\ \text{rpm} \leq$  Max average input speed of size 20 3,000 rpm

OK

Check whether the maximum input speed is equal to or less than the values specified in the rating table.  
 $n_{i\ max} = 3,720\ \text{rpm} \leq 600\ \text{rpm}$  (maximum input speed of size 20)

OK

Check whether  $T_1$  and  $T_3$  are within peak torques (Nm) on start and stop in the rating table.

$$T_1 = 70\ \text{Nm} \leq 113\ \text{Nm} \text{ (Limit for repeated peak torque, size 20)}$$

$$T_3 = 35\ \text{Nm} \leq 113\ \text{Nm} \text{ (Limit for repeated peak torque, size 20)}$$

OK

Check whether  $T_s$  is equal to or less than limit for momentary torque (Nm) in the rating table.  
 $T_s = 180\ \text{Nm} \leq 256\ \text{Nm}$  (momentary max. torque of size 20)

OK

Calculate life and check whether the calculated life meets the requirement.

$$L_{50} = 20,000 \cdot \left(\frac{80\ \text{Nm}}{30.2\ \text{Nm}}\right)^{10/3} \cdot \left(\frac{3,000\ \text{rpm}}{1,432\ \text{rpm}}\right) = 25,809,937 \text{ (hours)} \geq 30,000 \text{ (hours)}$$

OK

The selection of model number HPN-20A-31 is confirmed from the above calculations.

Refer to the Caution note at the bottom of page 61.

Review the operation conditions, size and reduction ratio.

Sold & Serviced By:

 **ELECTROMATE**

Toll Free Phone (877) SERV098

Toll Free Fax (877) SERV099

www.electromate.com

sales@electromate.com

# Harmonic Planetary<sup>®</sup> HPN Value Series

HPN Precision Planetary Gearheads are Quiet, Lightweight and Compact with Low Cost and Quick Delivery.

HPN Planetary gearheads feature a robust design utilizing helical gears for quiet performance and long life. These gearheads are available with short lead times and are designed to couple to any servomotor with our Quick Connect™ coupling. HPN gearheads are suitable for use in a wide range of applications for precision motion control and positioning. HPN Harmonic Planetary® gears are available in 5 sizes: 11, 14, 20, 32, and 40, with reduction ratios ranging from 3:1 to 31:1.

- ◆ **Backlash: One Stage <5 arc-min**  
**Two Stage <7 arc-min**
- ◆ **Low gear ratios, 3:1 to 31:1**
- ◆ **High efficiency**
- ◆ **Helical gearing**
- ◆ **Quiet design: Noise <58dB (Size 14)**



Sold & Serviced By:  
 **ELECTROMATE**

Toll Free Phone (877) SERV098

Toll Free Fax (877) SERV099

[www.electromate.com](http://www.electromate.com)

[sales@electromate.com](mailto:sales@electromate.com)

Integrated output  
shaft and carrier

Motor mounting flange

Deep groove,  
output bearings allow  
high shaft loads

Ground helical gear for quiet  
performance and long life

Quick Connect™ coupling for  
easy mounting of any servomotor

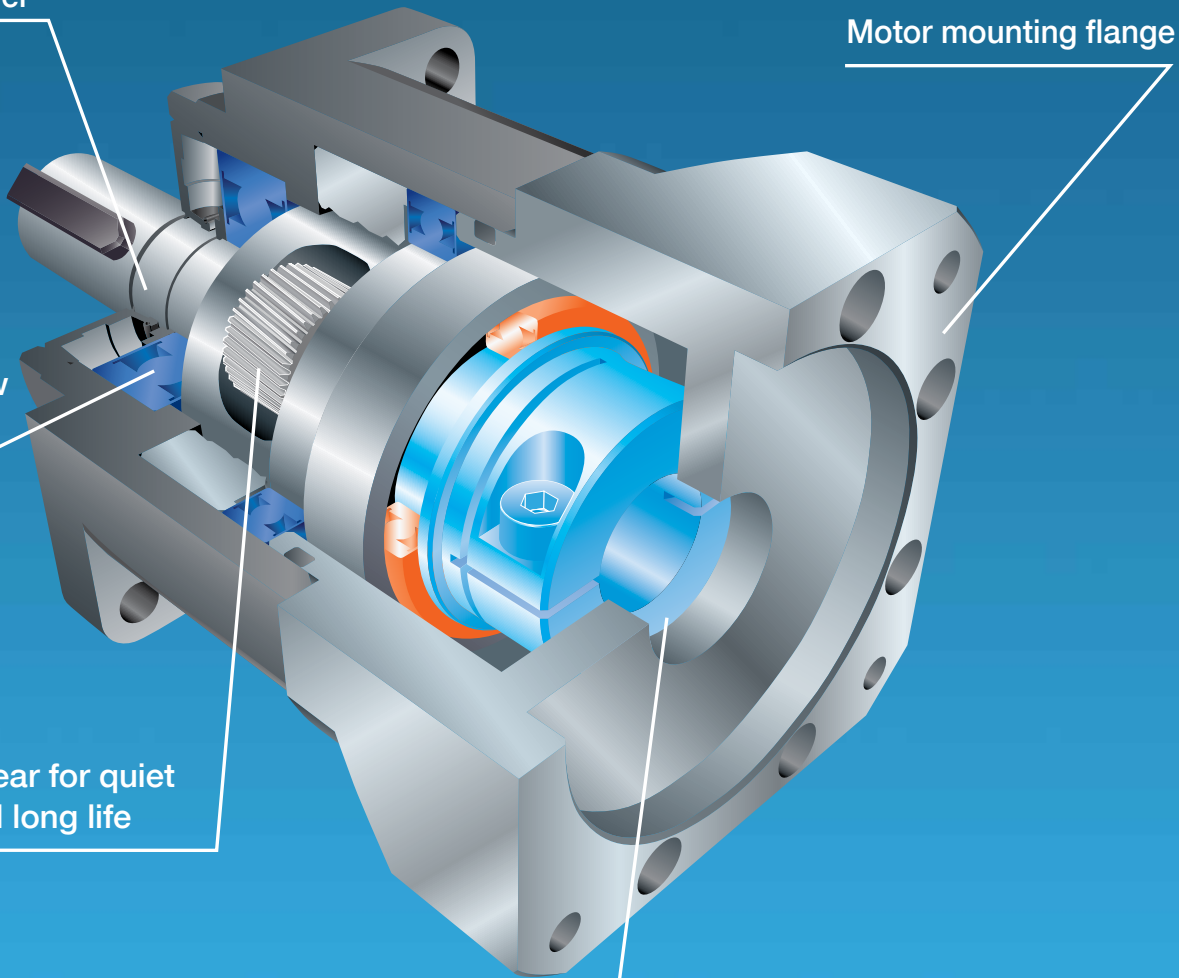

Sold & Serviced By:  
 **ELECTROMATE**

Toll Free Phone (877) SERV098  
Toll Free Fax (877) SERV099  
[www.electromate.com](http://www.electromate.com)  
[sales@electromate.com](mailto:sales@electromate.com)

## Harmonic Drive LLC

### Boston US Headquarters

247 Lynnfield Street  
Peabody, MA 01960

### New York Sales Office

100 Motor Parkway  
Suite 116  
Hauppauge, NY 11788

### California Sales Office

333 W. San Carlos Street  
Suite 1070  
San Jose, CA 95110

### Chicago Sales Office

137 N. Oak Park Ave., Suite 410  
Oak Park, IL 60301

**T: 800.921.3332**

**T: 978.532.1800**

**F: 978.532.9406**

**[www.HarmonicDrive.net](http://www.HarmonicDrive.net)**

### Group Companies

Harmonic Drive Systems, Inc.  
6-25-3 Minami-Ohi, Shinagawa-ku  
Tokyo 141-0013, Japan

Harmonic Drive AG  
Hoenbergstrasse, 14, D-6555  
Limburg/Lahn Germany

Harmonic Drive® and HarmonicPlanetary® are registered trademarks and Quick Connect is a trademark of Harmonic Drive LLC. All other trademarks are property of their respective owners.



Sold & Serviced By:

 **ELECTROMATE**

Toll Free Phone (877) SERV098

Toll Free Fax (877) SERV099

[www.electromate.com](http://www.electromate.com)  
[sales@electromate.com](mailto:sales@electromate.com)

Rev 02-15