

This guide has been developed as a quick reference tool for ElectroCraft products. It is not intended to replace technical documentation or proper use of standards and codes in installation of product.

Because of the variety of uses for the products described in this publication, those responsible for the application and use of this product must satisfy themselves that all necessary steps have been taken to ensure that each application and use meets all performance and safety requirements, including all applicable laws, regulations, codes and standards.

Reproduction of the contents of this copyrighted publication, in whole or in part without written permission of ElectroCraft is prohibited.

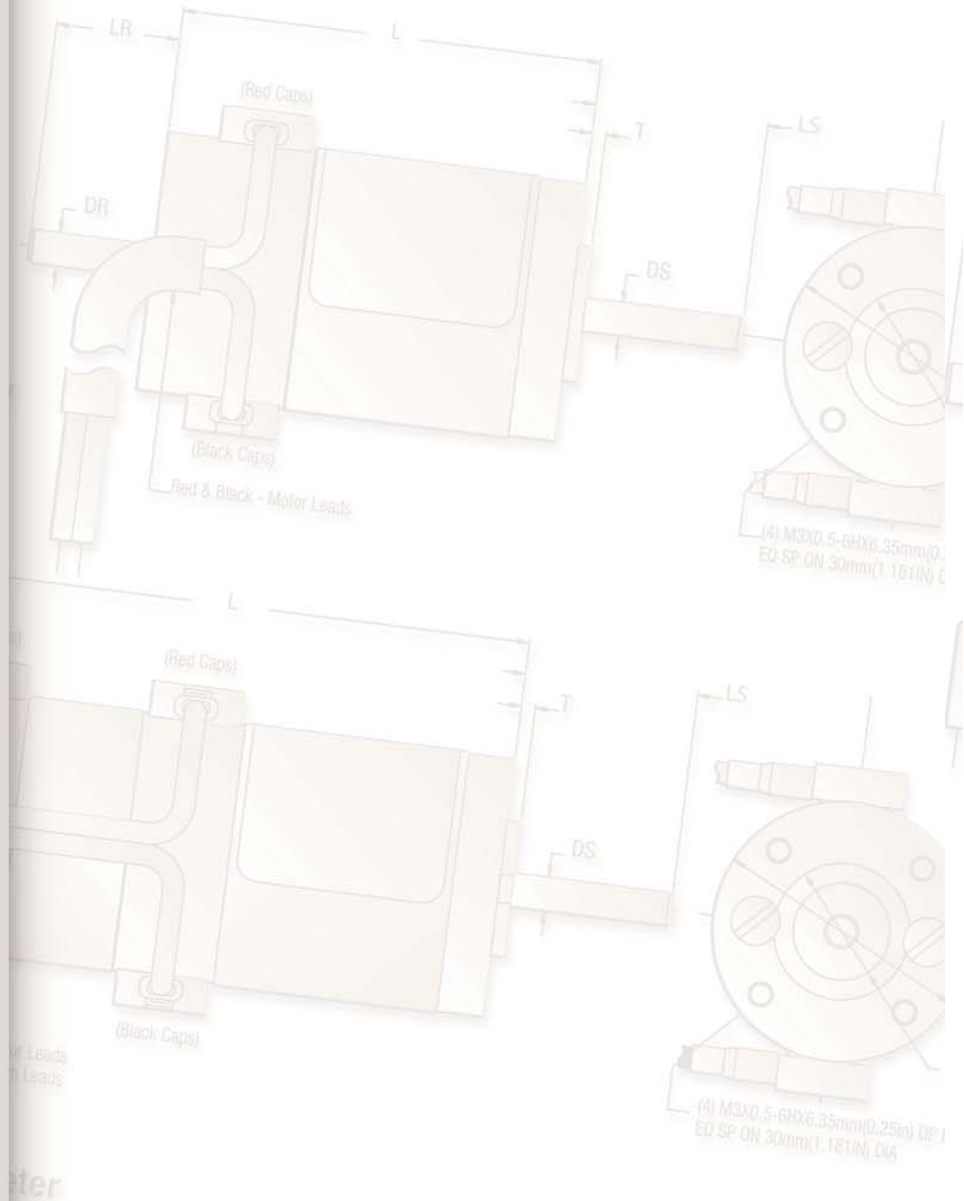

Table of Contents

ElectroCraft Engineering Motor Solutions	1
ElectroCraft G Series Motors	
G240 Series	2
G360 Series	4
G640 Series	6
G680 Series	8
G700Series	10
G720 Series	12
G Series Model Designations	14
ElectroCraft R Series Motor Gearboxes	16
R Series Model Designations	18
ElectroCraft T Series Transaxle Motors	20
T Series Model Designations	22
ElectroCraft Nx Series Gear Motors	24
Nx Series Model Designations	26
ElectroCraft AC Motors Series	28
AC26 Motor Series	30
AC26 Motor Series Specifications	32
AC29 Motor Series	34
AC29 Motor Series Specifications	36
AC33 Motor Series	38
AC33 Motor Series Specifications	40
AC Series Model Designations	42
ElectroCraft E Series Motors	
E2200 Series Brushless Motors	44
E2600 Series Brushless Motors	46
E2900 Series Brushless Motors	48
E3300 Series Brushless Motors	50
E Series Model Designations	52
ElectroCraft Worldwide	55

Motor Only

(4) M3X0.5-6HX6.35mm(0.25IN) DP MIN
 EQ SP ON 30mm(1.181IN) DIA

(Black Caps)
 Red & Black - Motor Leads
 Blue & White - Tach Leads

Motor Tachometer

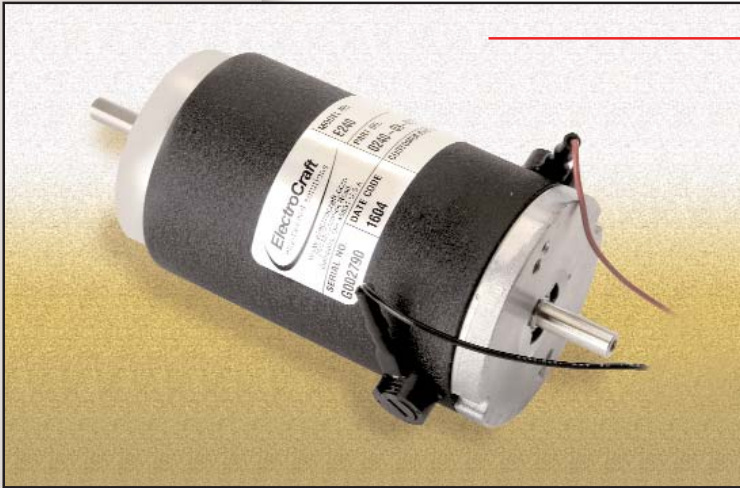

G240 Series

Features and Benefits

- *Dynamically balanced armatures insure smooth performance at any speed*
- *Rugged TENV construction for long life and reliability*
- *Non-contact sealed ball bearings for improved efficiency and smooth operation*
- *Replaceable brushes extend product life cycle*
- *2 Pole construction to support high speed applications*
- *Low ripple tachometer options for speed regulation*

ElectroCraft G240 Series

The 240 series offers reliable performance in a small package for your low voltage, lower torque range applications. This series utilizes mechanically aligned electromagnetics to provide consistent speed in either rotation. The 240 series is one of ElectroCrafts most widely used products worldwide.

Typical Applications

- Printers
- Tape Drives
- Semiconductor Processing
- Robotics
- X-ray Equipment
- Medical Pumps
- Light Industrial



(4) M3X0.5-6HX6.35mm(0.25in) DP MIN.
EQ SP QIN 30mm(1.181in) DIA

ElectroCraft
engineered solutions

G240 Series Performance Specifications

Motor Ratings	240	241	242	243
Continuous Stall Torque (Ncm)	20.5	26.8	35.3	38.8
Continuous Stall Torque (oz-in)	29	38	50	55
Peak Torque (Ncm)	169.5	197.7	247.2	282.5
Peak Torque (oz-in)	240	280	350	400
Maximum Terminal Voltage (V)	60	60	60	60
Maximum Operating Speed (rpm)	5000	5000	5000	5000

Mechanical Data				
Rotor Inertia (kg cm ²)	0.268	0.353	0.438	0.565
Rotor Inertia (oz-in-sec ²)	0.0038	0.0050	0.0062	0.0080
Damping Constant (Ncm/krpm)	0.071	0.106	0.141	0.212
Damping Constant (oz-in/krpm)	0.10	0.15	0.20	0.30
Thermal Resistance (C/watt)	5.0	4.6	4.2	4.0
Maximum Armature Temperature (C)	155	155	155	155
Maximum Friction Torque (Ncm)	2.1	2.1	2.1	2.1
Maximum Friction Torque (oz-in)	3	3	3	3
Maximum Radial Load (25mm from bearing) (Kg)	4.5	4.5	4.5	4.5
Maximum Radial Load (25mm from bearing) (lbs)	10	10	10	10
Weight (Kg)	1.0	1.0	1.0	1.0
Weight (lbs)	2.1	2.1	2.1	2.1

Electrical Data	A	B	C	A	B	C	A	B	C	A	B	C
Kt Torque Constant +-10% (Ncm/amp)	5.4	6.8	13.5	6.6	8.3	10.5	8.3	10.4	13.3	9.7	12.5	15.3
Kt Torque Constant +-10% (oz-in/amp)	7.7	9.6	19.2	9.3	11.7	14.9	11.7	14.7	18.8	13.8	17.7	21.6
Ke Voltage Constant +-10% (V/Krpm)	5.7	7.1	14.2	6.9	8.7	11.0	8.7	10.9	13.9	10.2	13.1	16.0
Terminal Resistance (ohms)	1.2	1.6	5.4	1.3	1.8	2.7	1.4	2	3	1.6	2.9	3.4
Maximum Continuous Current (A)	3.8	3.0	1.9	4.1	3.2	2.6	4.2	3.4	2.7	4.0	3.1	2.3
Maximum Peak Current (A)	31	24	13.9	30	24	19	31	24	19	34	26	21
Armature Inductance (mH)	1.9	3.0	8.2	2.6	4.1	6.5	3.3	5.2	8.3	4.1	6.8	10.3

Tachometer Electrical Data - (optional)				
Tachometer Specifications	T1	T2	T3	T4
Ke Voltage Constant +-10% (V/Krpm)	3	7	14	21
Terminal Resistance (ohms)	550	600	720	950
Ripple Peak-to-Peak at 1000 rpm (%)	5	5	5	5
Increase Motor Inertia by: (kg cm ²)	0.099	0.099	0.099	0.099
Increase Motor Inertia by: (oz-in-sec ²)	0.0014	0.0014	0.0014	0.0014

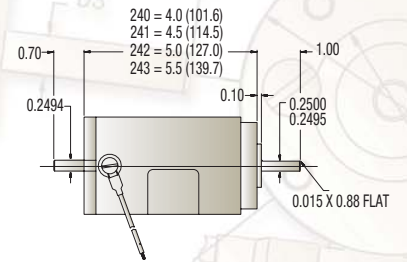
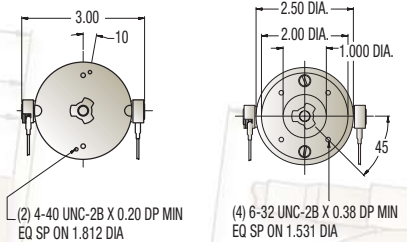

MOTOR ONLY OPTIONS SHOWN: ENGLISH MOUNTING, FLYING LEADS (19" STD)

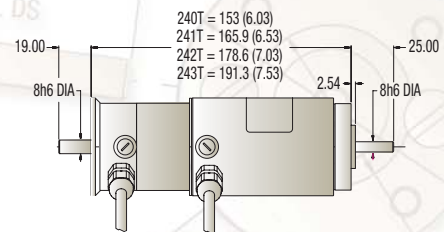
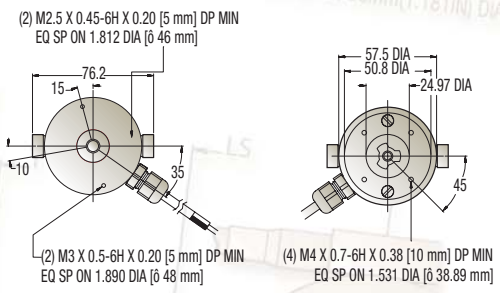

MOTOR TACHOMETER OPTIONS SHOWN:
METRIC MOUNTING, PG GLAND LEAD LENGTH (701 (27.5") STD)

G240

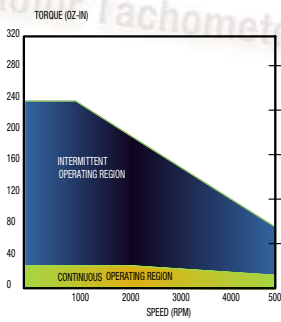

G241

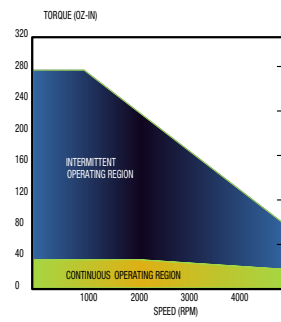

G242

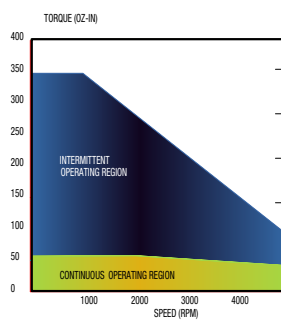

G243

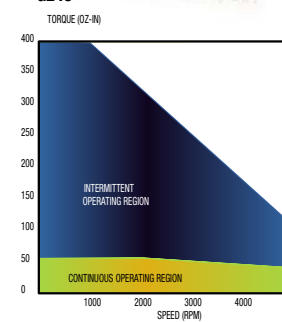



G360 Series

Features and Benefits

- *Dynamically balanced armatures insure smooth performance at any speed*
- *Rugged TENV construction for long life and reliability*
- *Non-contact sealed ball bearings for improved efficiency and smooth operation*
- *Replacable brushes extend product life cycle*
- *2 Pole construction to support high speed applications*

ElectroCraft G360 Series

The 360 series offers high performance in a small package for your low voltage, high torque applications. This series utilizes high energy rare earth magnets to achieve high torque to size ratios. When space is at a premium the 360 series is the product for you.

Typical Applications

- XY Plotters
- Printers
- Semiconductor Processing
- Robotics
- Pick and Place Machines
- Coordinate Measuring Devices
- Medical Pumps



(4) M3X0.5-6HX6.35mm(0.25in) DP MIN
EQ SP ON 30mm(1.181in) DIA

ElectroCraft
engineered solutions

G360 Series Performance Specifications

Motor Ratings	362	364
Continuous Stall Torque (Ncm)	8.5	14.1
Continuous Stall Torque (oz-in)	12	20
Peak Torque (Ncm)	31.8	56.5
Peak Torque (oz-in)	45	80
Maximum Terminal Voltage (V)	30	30
Maximum Operating Speed (rpm)	5000	5000

Mechanical Data		
Rotor Inertia (kg cm ²)	0.021	0.049
Rotor Inertia (oz-in-sec ²)	0.0003	0.0007
Damping Constant (Ncm/krpm)	0.141	0.141
Damping Constant (oz-in/krpm)	0.2	0.2
Thermal Resistance (C/watt)	7.8	7.5
Maximum Armature Temperature (C)	155	155
Maximum Friction Torque (Ncm)	1.1	1.1
Maximum Friction Torque (oz-in)	1.5	1.6
Maximum Radial Load (25mm from bearing) (Kg)	2.3	2.3
Maximum Radial Load (25mm from bearing) (lbs)	5	5
Weight (Kg)	0.3	0.5
Weight (lbs)	0.7	1.1

Electrical Data	A	A
Kt Torque Constant +-10% (Ncm/amp)	4.73	5.65
Kt Torque Constant +-10% (oz-in/amp)	6.7	8.0
Ke Voltage Constant +-10% (V/Krpm)	4.9	5.9
Terminal Resistance (ohms)	3.5	3.2
Maximum Continuous Current (A)	1.8	1.8
Maximum Peak Current (A)	7	10
Armature Inductance (mH)	1.1	1.3

Tachometer Specifications - (optional)		
Ke Voltage Constant +-10% (V/Krpm)	3	
Terminal Resistance (ohms)	42	
Ripple Peak-to-Peak at 1000 rpm (%)	5	
Increase Motor Inertia by: (kg cm ²)	0.007	
Increase Motor Inertia by: (oz-in-sec ²)	0.0001	

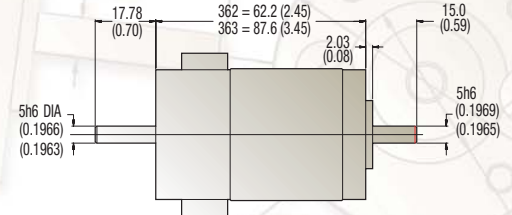
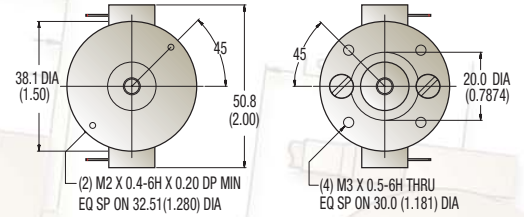

MOTOR ONLY OPTIONS SHOWN: METRIC MOUNTING, TERMINALS

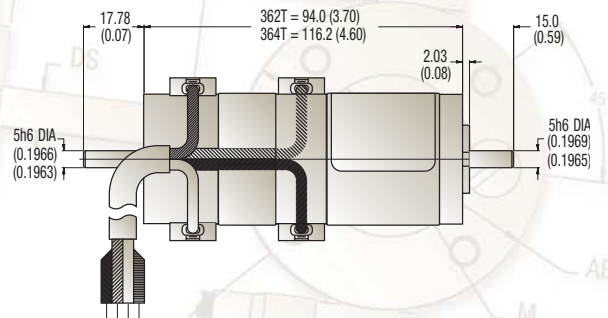
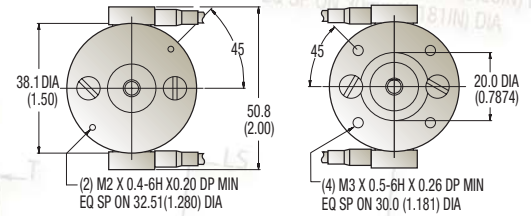

MOTOR TACHOMETER OPTIONS SHOWN: METRIC MOUNTING, FLYING LEADS (70° STD)

G362

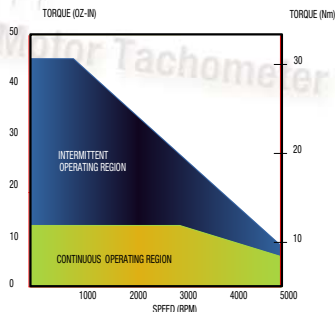

G364

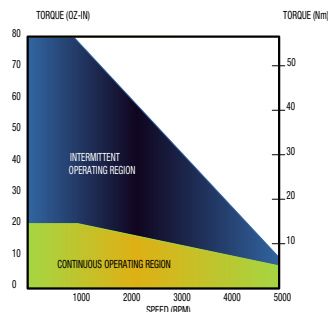

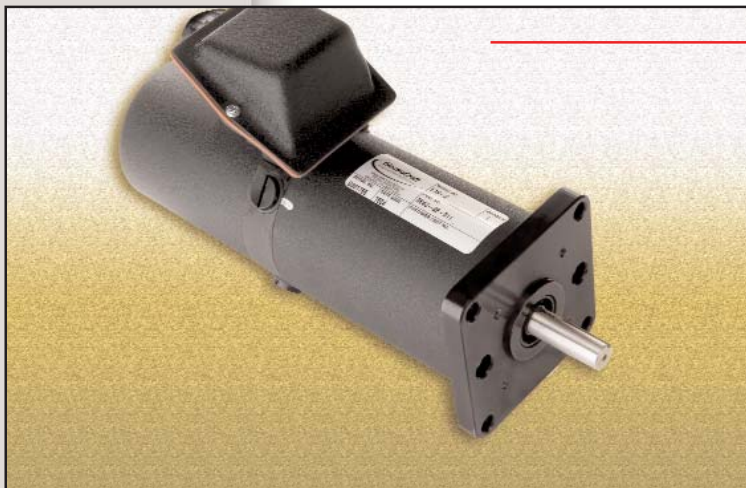

G640 Series

Features and Benefits

- *Dynamically balanced armatures insure smooth performance at any speed*
- *Rugged TENV and optional sealed construction for reliability in most environments*
- *Non-contact sealed ball bearings for improved efficiency and smooth operation*
- *Replaceable brushes extend product life cycle*
- *Low ripple tachometer options for speed regulation*

ElectroCraft G640 Series

The 640 servo series offers smooth performance for your mid to low voltage, mid-level torque applications. This series features four pole construction for reduced torque ripple and optional sealed design for more aggressive application environments.

Typical Applications

- Material Handling
- CNC Tool Changers
- Semiconductor Processing
- Robotics
- Medical Beds
- Magnetic Resonance Instruments
- Light Industrial



(4) M3X0.5-6HX0.35mm(0.25in) DP MIN
 ED SP ON 30mm(1.181in) DIA

ElectroCraft
 engineered solutions

G640 Series Performance Specifications

Motor Ratings	642	643	644
Continuous Stall Torque (Ncm)	70.6	116.5	148.3
Continuous Stall Torque (oz-in)	100	165	210
Peak Torque (Ncm)	339.0	547.3	678.0
Peak Torque (oz-in)	480	775	960
Maximum Terminal Voltage (V)	90	90	90
Maximum Operating Speed (rpm)	4500	4500	4500

Mechanical Data			
Rotor Inertia (kg cm ²)	1.342	2.118	2.613
Rotor Inertia (oz-in-sec ²)	0.0190	0.0300	0.0370
Damping Constant (Ncm/krpm)	1.059	1.765	2.472
Damping Constant (oz-in/krpm)	1.50	2.50	3.50
Thermal Resistance (C/watt)	2.7	2.2	1.9
Maximum Armature Temperature (C)	155	155	155
Maximum Friction Torque (Ncm)	5.6	5.6	5.6
Maximum Friction Torque (oz-in)	8	8	8
Maximum Radial Load (25mm from bearing) (Kg)	13.6	13.6	13.6
Maximum Radial Load (25mm from bearing) (lbs)	30	30	30
Weight (Kg)	3.6	4.8	5.4
Weight (lbs)	8	10.5	12

Electrical Data	A	B	C	A	B	C	A	B	C
Kt Torque Constant +-10% (Ncm/amp)	8.3	10.5	16.7	11.8	15.1	23.7	12.0	15.4	30.9
Kt Torque Constant +-10% (oz-in/amp)	11.8	14.9	23.6	16.7	21.4	33.5	17.0	21.8	43.7
Ke Voltage Constant +-10% (V/Krpm)	8.7	11.0	17.5	12.4	15.9	24.8	12.6	16.2	32.4
Terminal Resistance (ohms)	0.5	0.7	1.5	0.5	0.7	1.5	0.4	0.5	1.7
Maximum Continuous Current (A)	8.5	6.7	4.2	9.9	7.7	4.9	12.3	9.6	4.8
Maximum Peak Current (A)	44	35	22	50	40	26	60	48	24
Armature Inductance (mH)	0.5	0.8	2.0	0.5	0.8	2.0	0.5	0.8	3.3

Tachometer Specifications (optional)	T1	T2	T3	T4
Ke Voltage Constant +-10% (V/Krpm)	3	7	14	21
Terminal Resistance (ohms)	38	50	95	180
Ripple Peak-to-Peak at 1000 rpm (%)	5	5	5	5
Increase Motor Inertia by: (kg cm ²)	0.141	0.141	0.141	0.141
Increase Motor Inertia by: (oz-in-sec ²)	0.002	0.002	0.002	0.002

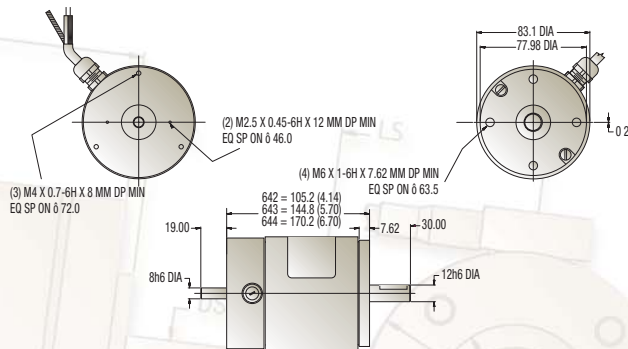

MOTOR TACHOMETER OPTIONS SHOWN: METRIC MOUNTING, PG GLAND LEAD LENGTH (800 (31.5" STD))

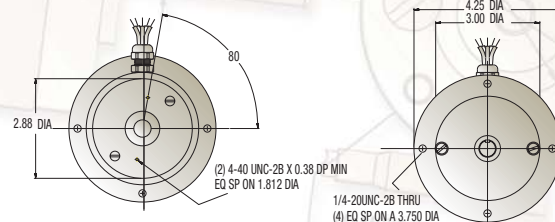

MOTOR TACHOMETER OPTIONS SHOWN: NEMA MOUNTING(42C), PG GLAND LEAD LENGTH (24" STD)

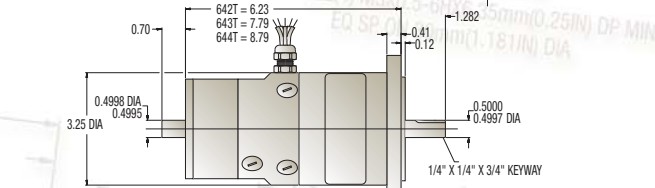

MOTOR TACHOMETER OPTIONS SHOWN: SQUARE MOUNTING, JUNCTION BOX, SEALED

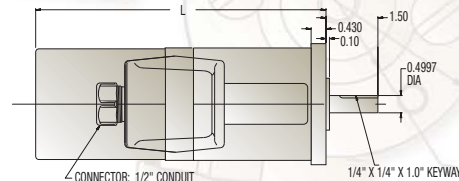
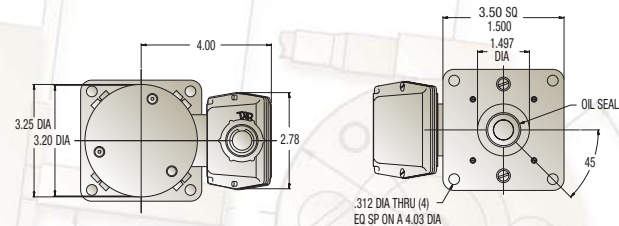

G642

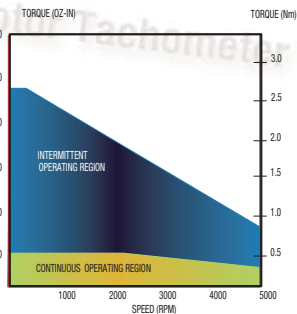

G643

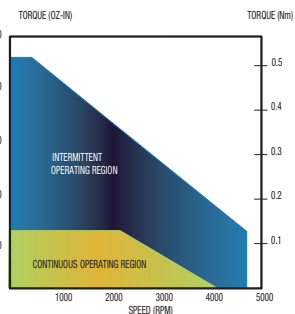

G644

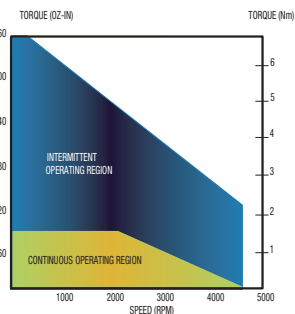



G680 Series

Features and Benefits

- *Dynamically balanced armatures insure smooth performance at any speed*
- *Rugged TENV Construction for reliability and long life*
- *Non-contact sealed ball bearings for improved efficiency and smooth operation*
- *Replaceable brushes extend product life cycle*
- *2 Pole construction to support high speed applications*
- *High efficiency to maximize battery life*

ElectroCraft G680 Series

The 680 series offers high output in a highly efficient package for mid to low voltage, mid-level to high torque applications. This series combines the newest winding technology with premium materials to provide an efficient product significantly extending use cycles for remotely powered applications.

Typical Applications

- Electric Wheelchairs
- Single Person Electric Vehicles
- Pumps
- Blowers
- Medical Beds
- Tape Transporters
- Floor Care Equipment



G680 Series Performance Specifications

Motor Ratings	681	683	685	689
Continuous Stall Torque (Nom)	63.6	84.7	130.6	141.2
Continuous Stall Torque (oz-in)	90	120	185	200
Peak Torque (Ncm)	317.8	480.2	762.7	946.3
Peak Torque (oz-in)	450	680	1080	1340
Maximum Terminal Voltage (V)	90	90	90	90
Maximum Operating Speed (rpm)	5300	5300	5300	5300

Mechanical Data				
Rotor Inertia (kg cm ²)	1.624	2.260	3.884	4.802
Rotor Inertia (oz-in-sec ²)	0.0230	0.0320	0.0550	0.0680
Damping Constant (Ncm/krpm)	0.777	0.989	1.271	1.342
Damping Constant (oz-in/krpm)	1.10	1.40	1.80	1.90
Thermal Resistance (C/watt)	2.9	2.8	2.0	1.6
Maximum Armature Temperature (C)	155	155	155	155
Maximum Friction Torque (Ncm)	4.2	4.9	5.6	6.4
Maximum Friction Torque (oz-in)	6	7	8	9
Maximum Radial Load (25mm from bearing) (Kg)	13.6	13.6	13.6	13.6
Maximum Radial Load (25mm from bearing) (lbs)	30	30	30	30
Weight (Kg)	2.7	2.9	3.2	3.6
Weight (lbs)	6	6.5	7	8

Electrical Data	A			B			C			A			B			C		
Kt Torque Constant +10% (Ncm/amp)	6.6	10.0	13.3	6.1	10.4	13.7	6.1	6.6	13.1	6.6	10.5	13.1						
Kt Torque Constant +10% (oz-in/amp)	9.4	14.1	18.9	8.7	14.7	19.5	8.8	9.4	13.5	9.3	14.9	18.6						
Ke Voltage Constant +10% (V/Krpm)	7.0	10.5	14.0	6.4	10.8	14.4	6.5	7.0	13.7	6.9	11.0	13.8						
Terminal Resistance (ohms)	0.3	0.6	1	0.2	0.5	1.0	0.2	0.2	0.5	0.2	0.3	0.5						
Maximum Continuous Current (A)	10.0	7.0	5.5	10.0	9.0	2.3	12.0	10.0	4.6	12.0	10.0	8.0						
Maximum Peak Current (A)	50	35	25	55	50	15	80	80	65	80	80	70						
Armature Inductance (mH)	0.8	1.9	3.3	0.6	1.8	3.1	0.5	0.7	2.1	0.5	1.2	2.0						

Tachometer Specifications (optional)	T1	T2	T3	T4
Ke Voltage Constant +10% (V/Krpm)	3	7	14	21
Terminal Resistance (ohms)	535	550	570	590
Ripple Peak-to-Peak at 1000 rpm (%)	5	5	5	5
Increase Motor Inertia by: (kg cm ²)	0.141	0.141	0.141	0.141
Increase Motor Inertia by: (oz-in-sec ²)	0.002	0.002	0.002	0.002

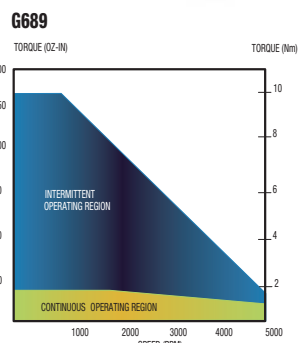
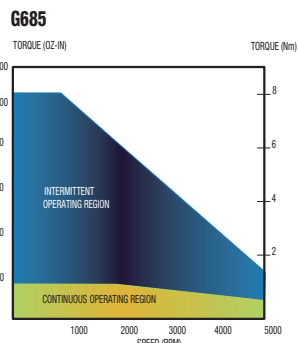
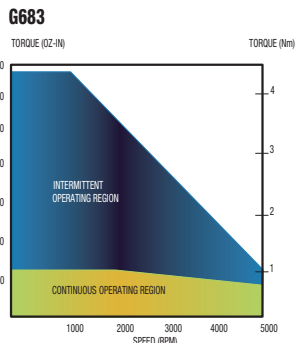
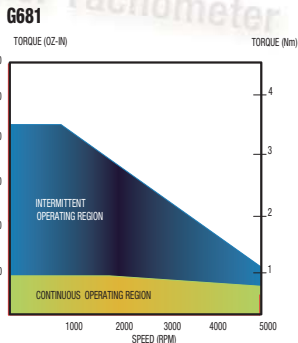
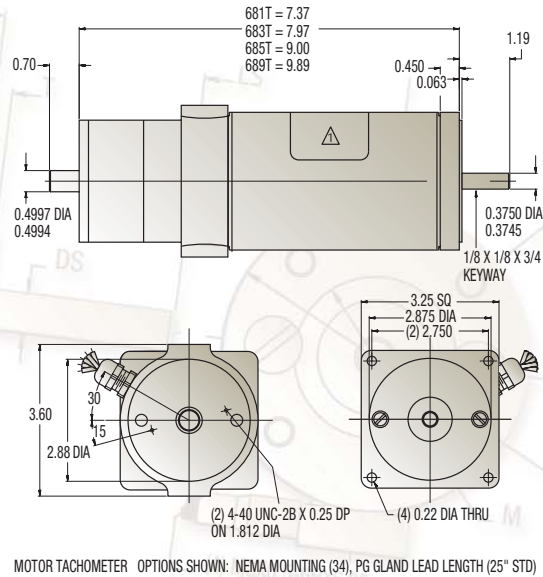
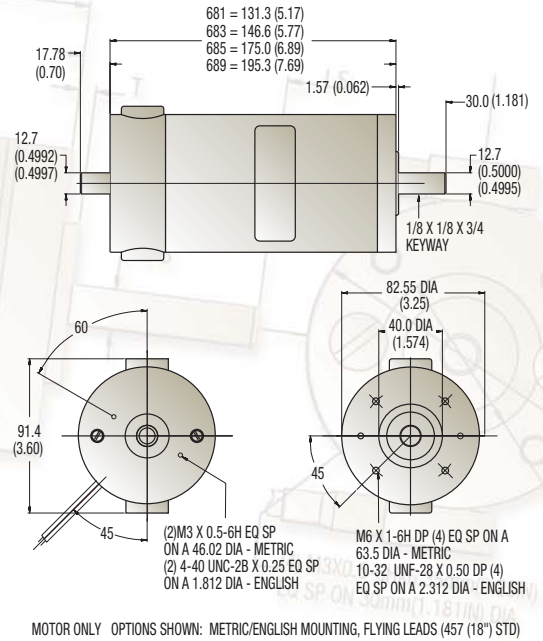



G700 Series

Features and Benefits

- Dynamically balanced armatures insure smooth performance at any speed
- Rugged TENV Construction for reliability and long life
- Non-contact sealed ball bearings for improved efficiency and smooth operation
- Replaceable brushes extend product life cycle
- Low ripple tachometer options for speed regulation

ElectroCraft G700 Series

The 700 series offers high output for low to mid voltages, high torque applications. This series features robust four-pole construction and premium materials to provide a reliable solution.

Typical Applications

- Electric Wheelchairs
- Packaging Equipment
- Medical Beds
- Machine Tool
- Robotics



G700 Series Performance Specifications

Motor Ratings	701	702	703
Continuous Stall Torque (Ncm)	105.9	211.9	289.5
Continuous Stall Torque (oz-in)	150	300	410
Peak Torque (Ncm)	529.7	953.4	1412.4
Peak Torque (oz-in)	750	1350	2000
Maximum Terminal Voltage (V)	90	90	90
Maximum Operating Speed (rpm)	4000	4000	4000

Mechanical Data			
Rotor Inertia (kg cm ²)	7.062	10.592	14.123
Rotor Inertia (oz-in-sec ²)	0.1000	0.1500	0.2000
Damping Constant (Ncm/krpm)	3.531	4.943	7.062
Damping Constant (oz-in/krpm)	5.00	7.00	10.00
Thermal Resistance (C/watt)	2.2	1.6	1.3
Maximum Armature Temperature (C)	155	155	155
Maximum Friction Torque (Ncm)	10.6	10.6	10.6
Maximum Friction Torque (oz-in)	15	15	15
Maximum Radial Load (25mm from bearing) (Kg)	13.6	13.6	13.6
Maximum Radial Load (25mm from bearing) (lbs)	30	30	30
Weight (Kg)	2.8	3.9	5.0
Weight (lbs)	6.1	8.5	11

Electrical Data	A	B	A	B	A	B
Kt Torque Constant +-10% (Ncm/amp)	14.2	23.0	6.9	33.3	11.3	37.4
Kt Torque Constant +-10% (oz-in/amp)	20.1	32.6	9.8	47.1	16.0	52.9
Ke Voltage Constant +-10% (V/Krpm)	14.9	24.1	7.2	43.4	11.8	49.3
Terminal Resistance (ohms)	0.7	1.6	0.2	1.4	0.2	1
Maximum Continuous Current (A)	7.5	4.6	13	6.4	13	7.7
Maximum Peak Current (A)	41	25	90	29	90	38
Armature Inductance (mH)	1.7	4.5	0.3	5.0	0.5	7.3

Tachometer Specifications (optional)	T1	T2	T3	T4
Ke Voltage Constant +-10% (V/Krpm)	3	7	14	21
Terminal Resistance (ohms)	535	550	570	590
Ripple Peak-to-Peak at 1000 rpm (%)	5	5	5	5

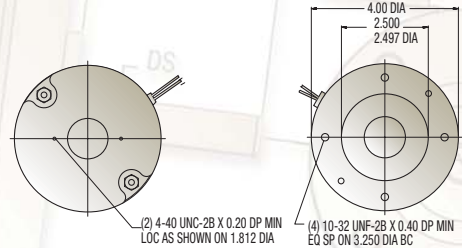
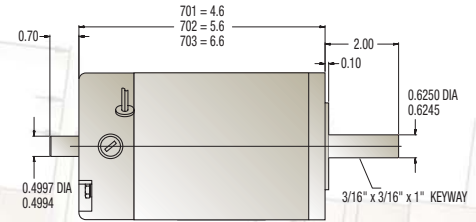

MOTOR ONLY OPTIONS SHOWN: ENGLISH MOUNTING, FLYING LEADS (19\"/>

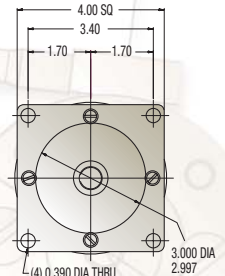
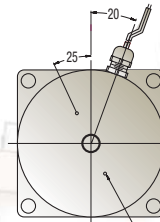
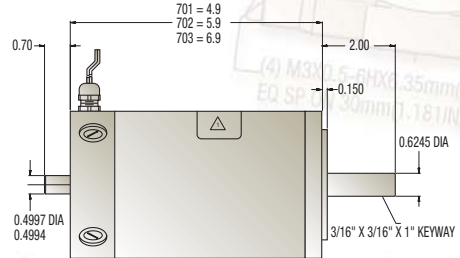

MOTOR ONLY OPTIONS SHOWN: SQUARE MOUNTING, PG GLAND (24\"/>

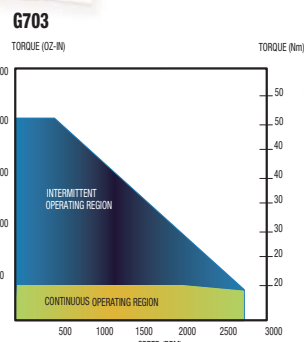
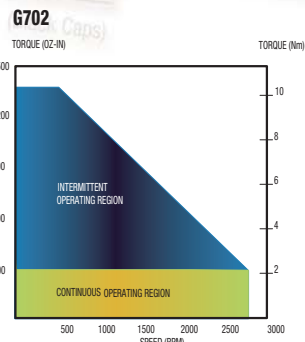
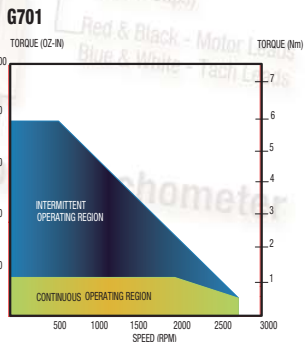



G720 Series

Features and Benefits

- *Dynamically balanced armatures insure smooth performance at any speed*
- *Rugged TENV Construction and optional sealed construction for reliability in most environments*
- *Non-contact sealed ball bearings for improved efficiency and smooth operation*
- *Replaceable brushes extend product life cycle*
- *Low ripple tachometer options for speed regulation*

ElectroCraft G720 Series

The 720 servo series offers smooth performance for high voltage, high torque applications. This series features premium construction and materials providing smooth and highly accurate performance across the operating speed range. If precision in motion is your goal this product is the choice.

Typical Applications

- CNC Machine Tools
- Packaging Equipment
- Robotics
- Light Industrial



G720 Series Performance Specifications

Motor Ratings	726	727	728
Continuous Stall Torque (Ncm)	250.7	321.3	402.5
Continuous Stall Torque (oz-in)	355	455	570
Peak Torque (Ncm)	1016.9	1468.9	2033.9
Peak Torque (oz-in)	1440	2080	2880
Maximum Terminal Voltage (V)	120	120	120
Maximum Operating Speed (rpm)	3000	3000	3000

Mechanical Data			
Rotor Inertia (kg cm ²)	7.062	7.768	12.358
Rotor Inertia (oz-in-sec ²)	0.1000	0.1100	0.1750
Damping Constant (Ncm/krpm)	7.062	8.827	10.592
Damping Constant (oz-in/krpm)	10.00	12.50	15.00
Thermal Resistance (C/watt)	1.4	1.3	1.1
Maximum Armature Temperature (C)	155	155	155
Maximum Friction Torque (Ncm)	17.7	17.7	17.7
Maximum Friction Torque (oz-in)	25	25	25
Maximum Radial Load (25mm from bearing) (Kg)	18.1	18.1	18.1
Maximum Radial Load (25mm from bearing) (lbs)	40	40	40
Weight (Kg)	5.9	6.8	9.5
Weight (lbs)	13	15	21

Electrical Data	A	B	C	A	B	C	A	B	C
Kt Torque Constant +-10% (Ncm/amp)	15.0	19.6	30.1	20.0	32.1	40.0	19.7	28.1	33.6
Kt Torque Constant +-10% (oz-in/amp)	21.3	27.7	42.6	28.3	45.4	56.7	27.9	39.8	47.8
Ke Voltage Constant +-10% (V/Krpm)	15.8	20.5	31.6	21.0	33.6	42.0	20.7	29.5	35.4
Terminal Resistance (ohms)	0.4	0.6	1	0.4	0.8	1.1	0.4	0.5	0.7
Maximum Continuous Current (A)	16.5	12.8	8.3	16.0	10.0	8.0	20.0	14.0	13.0
Maximum Peak Current (A)	75	57	37	80	50	40	100	80	60
Armature Inductance (mH)	0.6	1.0	2.4	0.7	1.8	2.8	0.4	0.9	1.3

Tachometer Specifications (optional)	T1	T2	T3	T4
Ke Voltage Constant +-10% (V/Krpm)	3	7	14	21
Terminal Resistance (ohms)	38	50	95	160
Ripple Peak-to-Peak at 1000 rpm (%)	5	5	5	5

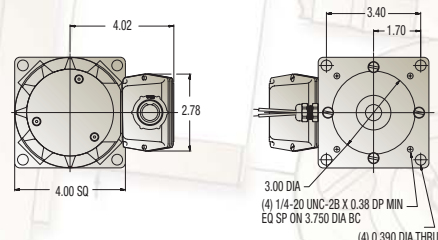
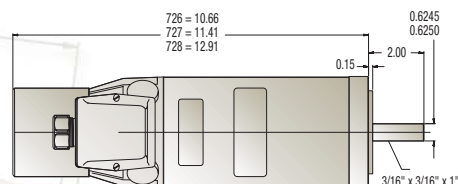

MOTOR TACHOMETER OPTIONS SHOWN: SQUARE MOUNTING, JUNCTION BOX, SEALED

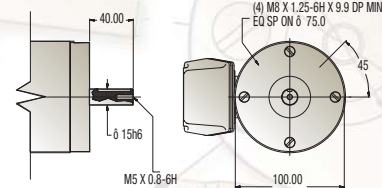
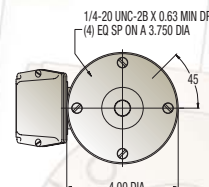
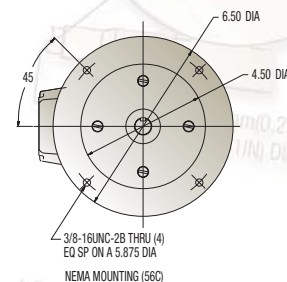
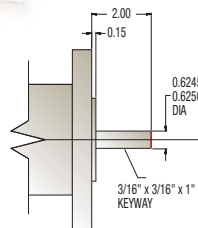

G726

G727

G728

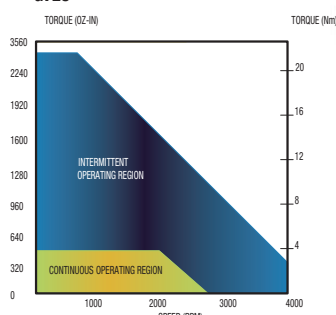
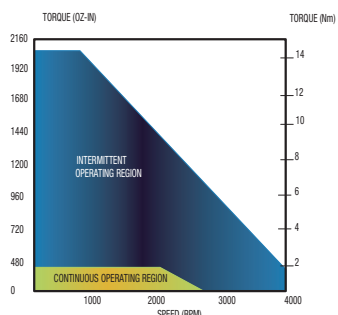
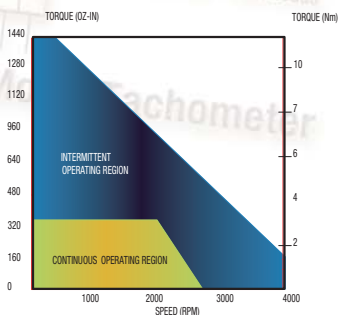

ElectroCraft G Series Model Designations **G685T - AETSF1**

Series- Brush Type Servo Motors

Frame Designator

24 = 240 (2.25" Diameter)
36 = 360 (1.50" Diameter)
64 = 640 (3.25" Diameter, 4-pole)
68 = 680 (3.25" Diameter, 2-pole)
70 = 700 (4.00" Diameter, under 90 VDC)
72 = 720 (4.00" Diameter, over 90 VDC)

Length Designator

0 - 9 see product pages

Tachometer Designator (omit if not applicable)

T = Tachometer

Winding Designator

A- C, Z see product pages, Z= custom

Mounting Designator

E = English
M = Metric
N = Nema
Z = Custom

Lead Designator

F = Flying leads- see catalog if applicable
C = Standard connector- see catalog if applicable
T = Terminals on motor- see catalog if applicable
Z = Custom

Environmental Designator (omit if not applicable)

S= Sealed 640, 700 and 720 only
Z= Custom

Feedback Designator (omit if not applicable)

L = 500 line count
F = 1000 line count
H = 2000 line count
Z = custom
(standard offering: TTL logic with complements and un-gated index)

Brake Designator (omit if not applicable)

1 = 12VDC
2 = 24 VDC
3 = 90 VDC
Z = custom

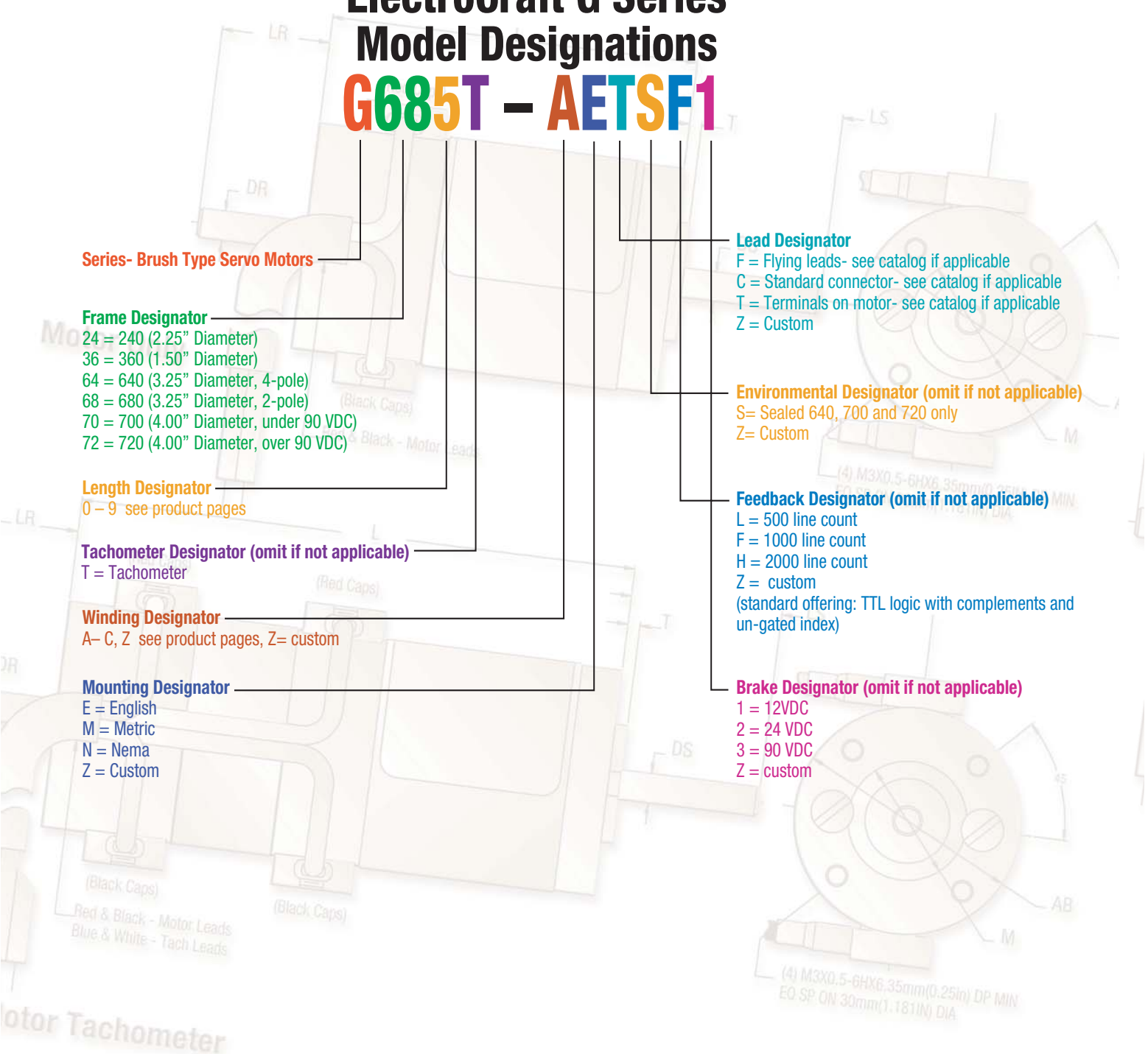

G Series Model Designations

Series- Brush Type Servo Motors

Frame Designator

Length Designator

**Tachometer Designator
(omit if not applicable)**

Winding Designator

Mounting Designator

Lead Designator

Environmental Designator (omit if not applicable)

Feedback Designator (omit if not applicable)

Brake Designator (omit if not applicable)

Please explain any custom (Z) designators:

Please indicate any special features not covered in the model number:

ElectroCraft specializes in assisting you with an engineered solutions to meet your application needs. We also specialize in sourcing and assembling value added components to your assembly. Please contact your area sales representative (see world wide locations section) for assistance with your application needs.

Need a product fast?! ElectroCraft carries a limited supply of off-the-shelf model variations available for shipment within 48 hours. Please contact your area sales representative or our inside sales staff for a complete listing of stocked model numbers and pricing sheet.

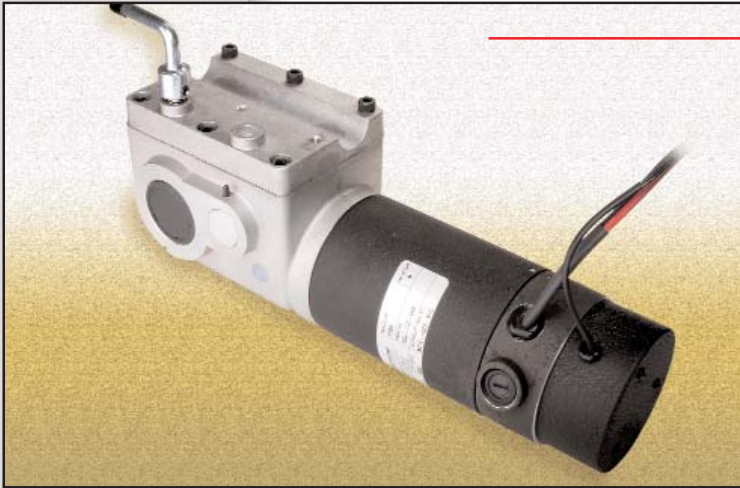

R Series Motor Gearboxes

Features and Benefits

- *Choice of output ratios to meet a variety of different applications*
- *Quiet transfer of power to the drive wheels providing a comfortable operating environment*
- *Highly efficient to extend product range and capabilities*
- *Robust all metallic gears providing long durable life*
- *Compatible with ElectroCraft brush and brushless motors for your application requirements*
- *Available with industry standard connectors for ease of drive connection*
- *Manual or non-manual release brake options*
- *Custom configurations available - please contact your local sales representative*

ElectroCraft R Series Motor Gearboxes

The R series products are designed for low voltage high torque applications typically found in battery operated vehicle. Combine a precision two stage gearbox with one of ElectroCraft's G series or E series motors to transfer power smoothly and quietly to your drive wheels. The gearbox features all metallic gearing hobbled to a precision AGMA 9 class to provide durable performance while maintaining low noise level. With four ratios to choose from and numerous motor combinations R series can meet a broad range of performance needs.

Typical Application

- Power Wheelchairs
- Lift Trucks
- Unmanned Ground Vehicles
- Robots
- Rotational Axes Drives
- Personal Electric Vehicles
- Single Person Golf Carts



(4) M3X0.5-6HX6.35mm(0.25m) DP MIN
EQ SP ON 30mm(1.181in) DIA

R Series Performance Specifications

Model	R702-A15	R685-A19	R685-A21	R683-A28
Ratio	15.46:1	19.03:1	21.00:1	28.62:1
Maximum No Load Speed ¹ (RPM)	3500	3500	3500	3500
Continuous Torque ² (LB-IN)	80	80	80	80
Continuous Speed (RPM)	210	160	145	120
Peak Torque (LB-IN)	400	440	495	550
Backlash (Degrees)	1	1	1	1
Maximum OHL (Over Hung Load)	250	250	250	250
Length (IN) - Dimensions (L)	11.15	11.65	11.65	10.50

1. Input Speed 2. Measured with 12 x 12 x 0.5 Heat Sink

Shaft Options and Standard Cover

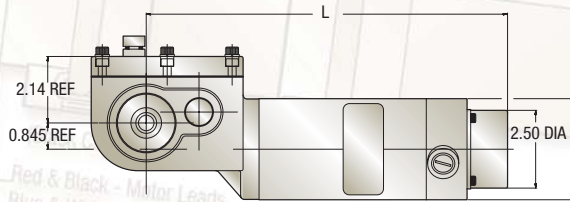
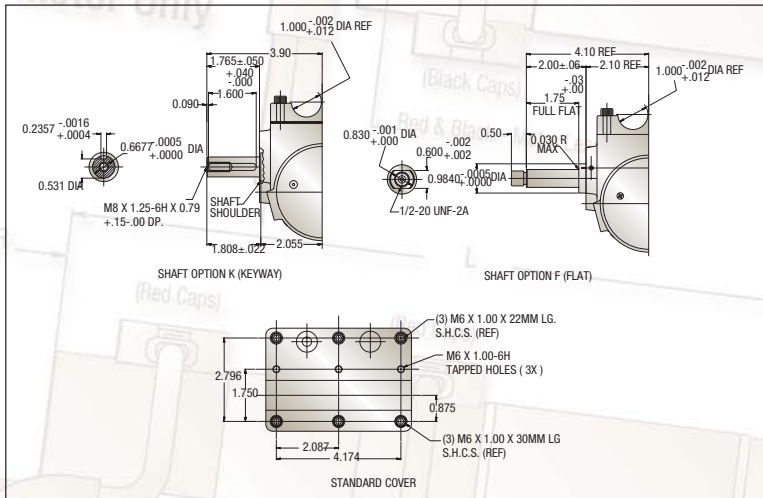

R680 SERIES

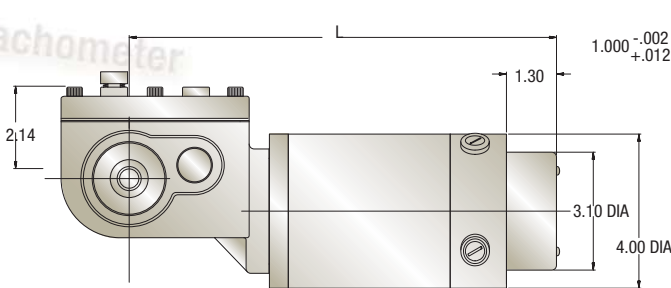

R700 SERIES

Handle Options

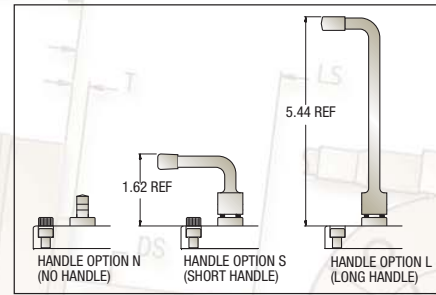

Lead Options

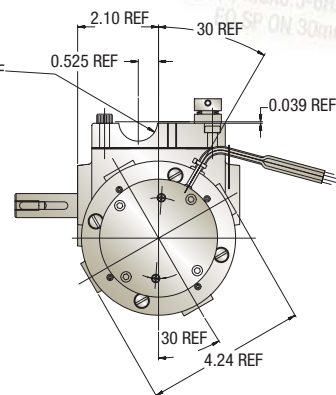
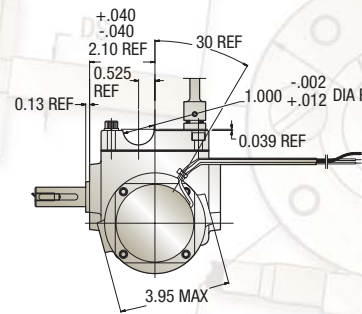
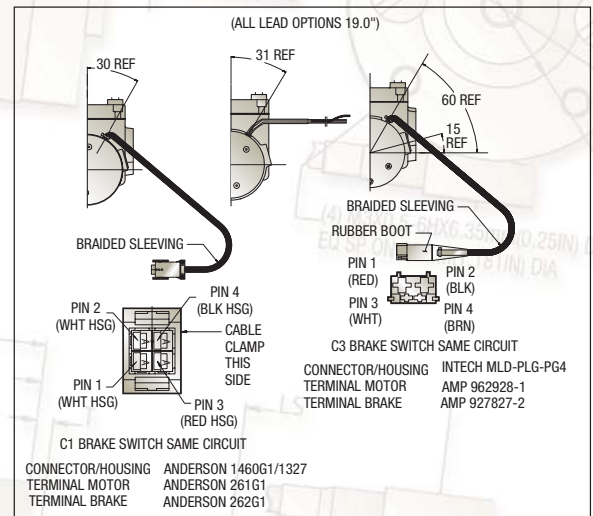

ElectroCraft R Series Model Designations

R685 – A15NSKF1

Series- Right Angle-Motor Drives

Frame Designator

- 68 = 680 (3.25" Diameter Brush Motor)
- 70 = 700 (4.00" Diameter Brush Motor)
- 29 = 290 (3.35" Diameter Brushless Motor)
- 33 = 330 (3.87" Diameter Brushless Motor)

Length Designator

0 – 9 see product pages

Winding Designator

A – Z, see product pages

Ratio Designator

- 15 = 15.46:1
- 19 = 19.03:1
- 21 = 21:1
- 28 = 28.62:1
- Z = custom

Disconnect Handle

- L = Long
- N = No Handle
- S = Short
- Z = Custom

Cover Mounting Pattern

- S = Standard
- Z = Custom

Output Shaft Designator

- F = Standard Flat Configuration
- K = Standard Keyway Configuration
- R = Standard Round Configuration
- Z = custom

Lead Designator

- F = Flying leads- see catalog if applicable
- C = Standard connector- see catalog if applicable
- Z = Custom

Brake Designator (omit if not applicable)

- 1 = 12VDC
- 2 = 24 VDC
- 3 = 90 VDC
- Z = custom

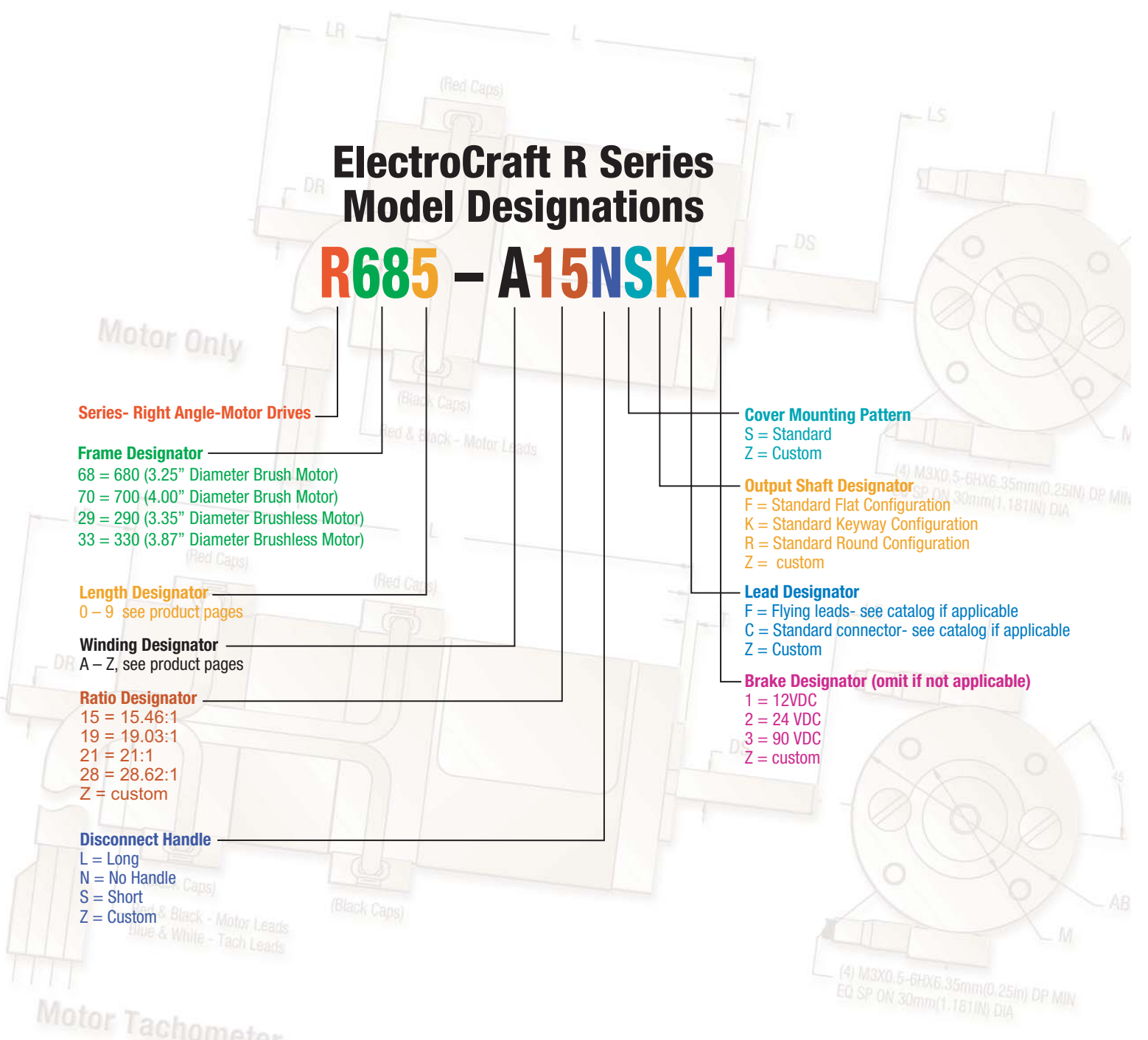

R Series Model Designations

Series- Right Angle-Motor Drives

Frame Designator

Length Designator

Winding Designator

Ratio Designator

Disconnect Handle

Cover Mounting Pattern

Output Shaft Designator

Lead Designator

Brake Designator (omit if not applicable)

Please explain any custom (Z) designators:

Please indicate any special features not covered in the model number:

ElectroCraft specializes in assisting you with an engineered solutions to meet your application needs. We also specialize in sourcing and assembling value added components to your assembly. Please contact your area sales representative (see world wide locations section) for assistance with your application needs.

Need a product fast?! ElectroCraft carries a limited supply of off-the-shelf model variations available for shipment within 48 hours. Please contact your area sales representative or our inside sales staff for a complete listing of stocked model numbers and pricing sheet.

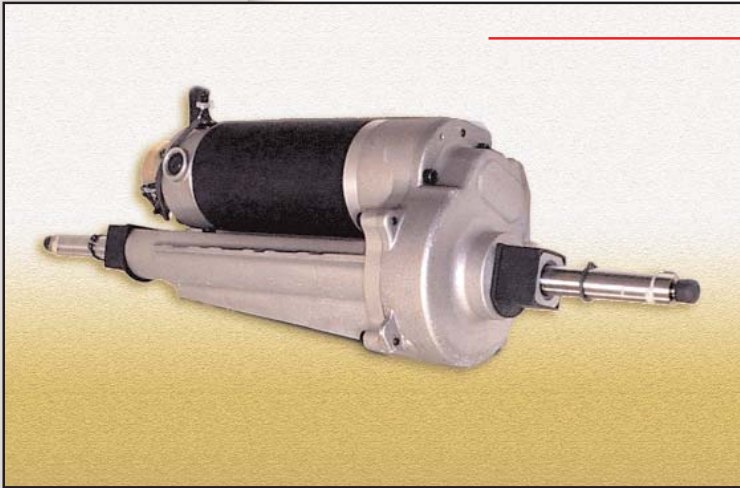

T Series Transaxle Motors

Features and Benefits

- *Choice of output ratios to meet a variety of different applications*
- *Quiet transfer of power to the drive wheels providing a comfortable operating environment*
- *Highly efficient to extend product range and capabilities*
- *Robust all metallic gears providing long durable life*
- *Compatible with ElectroCraft brush and brushless motors for all your application requirements*
- *Available with industry standard connectors for ease of drive connection*
- *Custom configurations available - please contact your local sales representative*

ElectroCraft T Series

The T series products are the choice for your battery operated vehicle requiring a differential axle. Combine a precision two stage transaxle with one of ElectroCraft's G series or E series motors to transfer power to either of the drive wheels. The transaxle features all metallic gearing hobbled to a precision AGMA 9 class to provide durable performance while maintaining a low noise level. With three ratios to choose from and numerous motor combinations T series can meet your performance needs.

Typical Applications

- Power scooters
- Single person golf carts
- Unmanned ground vehicles
- Robots
- Personal electric vehicles

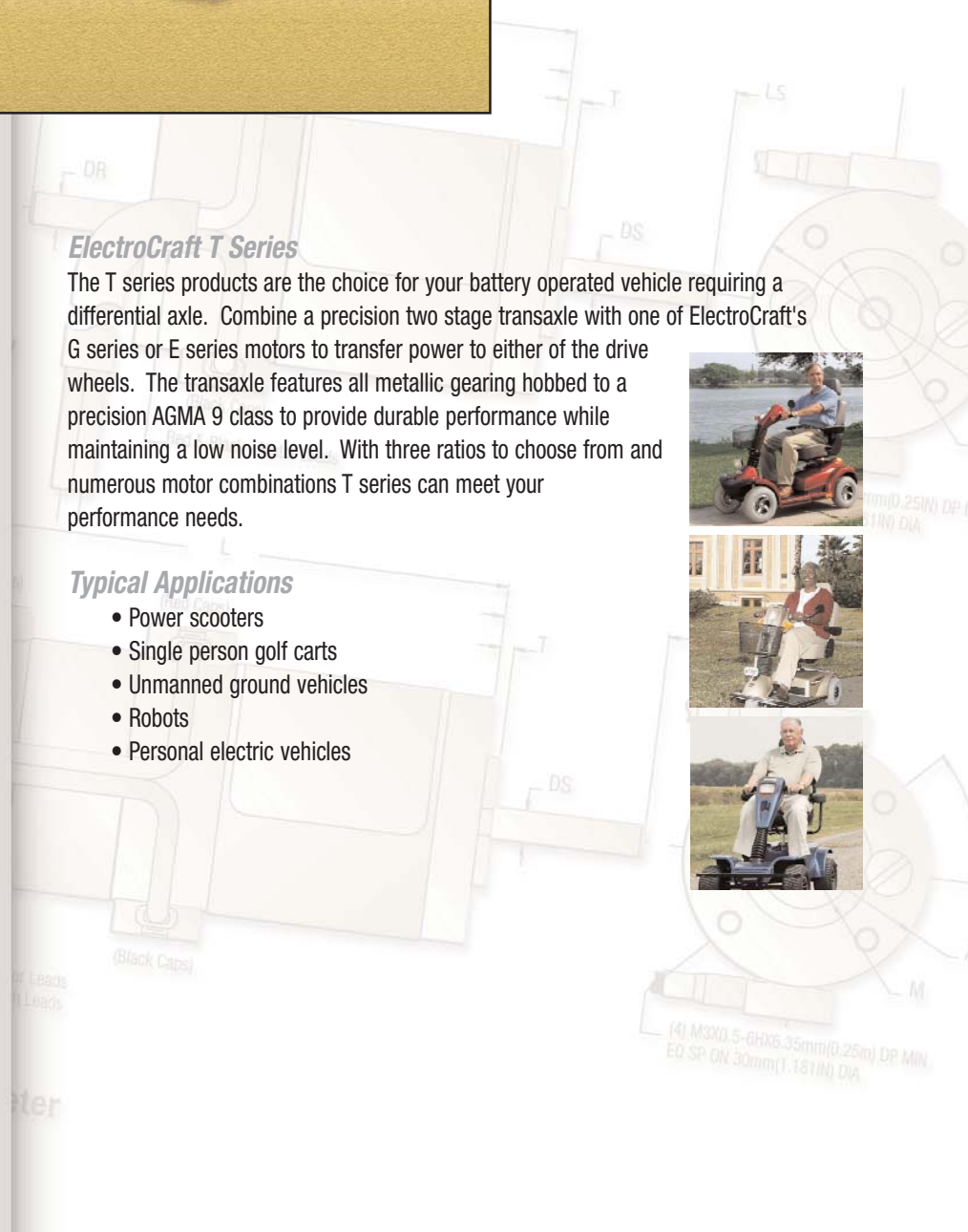

T Series Performance Specifications

Model	T685-B20	T685-B22	T685-B26
Ratio	19.93:1	22.02:1	25.97:1
Maximum No Load Speed ¹ (RPM)	3500	3500	3500
Continuous Torque ² (LB-IN)	80	80	80
Continuous Speed (RPM)	160	145	120
Peak Torque (LB-IN)	440	540	550
Backlash (Degrees)	1	1	1
Maximum OHL (Over Hung Load)	250	250	250
Length (IN) - Dimensions (L)	8.28	8.28	8.28

1. Input Speed 2. Motor Limitation

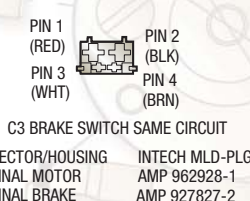
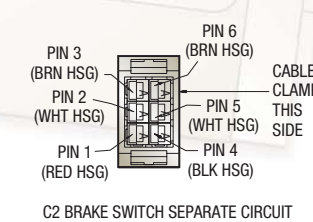
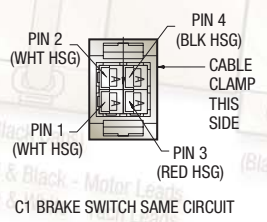
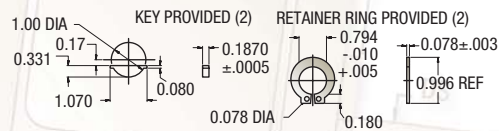
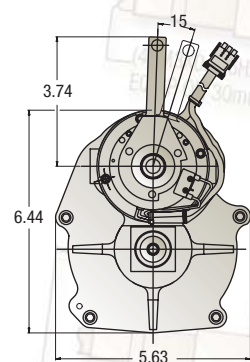
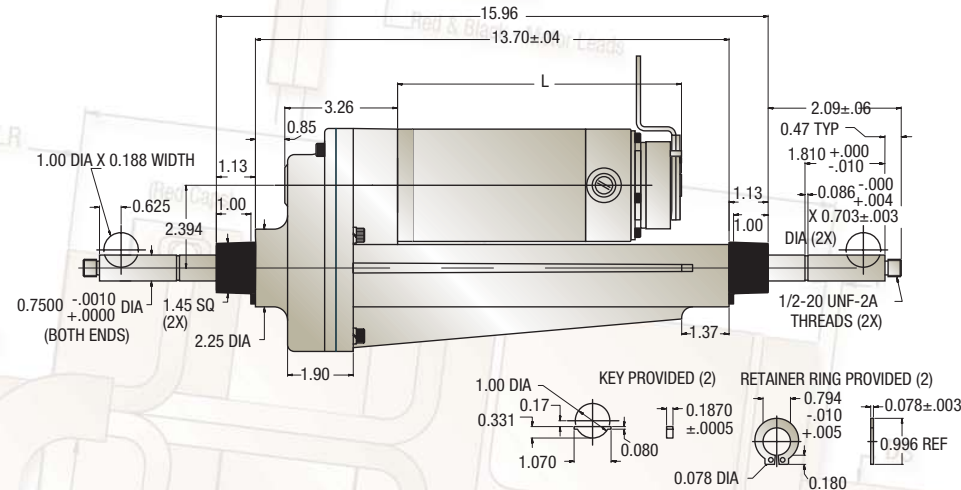

CONNECTOR/HOUSING ANDERSON 1460G1/1327
 TERMINAL MOTOR ANDERSON 261G1
 TERMINAL BRAKE ANDERSON 262G1

CONNECTOR/HOUSING ANDERSON 1460G2/1327
 TERMINAL MOTOR ANDERSON 261G1
 TERMINAL BRAKE ANDERSON 262G1

CONNECTOR/HOUSING INTECH MLD-PLG-PG4
 TERMINAL MOTOR AMP 962928-1
 TERMINAL BRAKE AMP 927827-2

(4) M3X0.5-6HX6.35mm(0.25in) DP MIN
 EQ SP ON 30mm(1.181in) DIA

Motor Tachometer

ElectroCraft T Series Model Designations

T685 – A19LF1

Series- Transaxle-Motor Drives

Frame Designator

68 = 680 (3.25" Diameter Brush Motor)

29 = 290 (3.35" Diameter Brushless Motor)

Length Designator

0 – 9 see product pages

Winding Designator

A – Z, see product pages

Ratio Designator

20 = 19.93:1

22 = 22.02:1

26 = 25.97:1

Z = Custom

Output Shaft Designator

L = Long shaft

S = Short shaft

Z = Custom

Lead Designator

F = Flying leads- see catalog if applicable

C = Standard connector

Z = Custom

Brake Designator (omit if not applicable)

1 = 12 VDC

2 = 24 VDC

2 = Custom

T Series Model Designations

Series-Transaxle-Motors Drives

Frame Designator

Length Designator

Winding Designator

Ratio Designator

Output Shaft Designator

Lead Designator

Brake Designator (omit if not applicable)

Please explain any custom (Z) designators:

Please indicate any special features not covered in the model number:

ElectroCraft specializes in assisting you with an engineered solutions to meet your application needs. We also specialize in sourcing and assembling value added components to your assembly. Please contact your area sales representative (see world wide locations section) for assistance with your application needs.

Need a product fast?! ElectroCraft carries a limited supply of off-the-shelf model variations available for shipment within 48 hours. Please contact your area sales representative or our inside sales staff for a complete listing of stocked model numbers and pricing sheet.

Motor Tachometer



Nx Series Gear Motors

Features and Benefits

- *Flange mounted*
- *All steel gears*
- *Ball bearings*
- *Precision die cast housing*

ElectroCraft Nx Series

The Nx Series products are a general purpose solution for your application needs. Combined with ElectroCraft G series motors and offered in small, medium and large sizes. The small and medium versions feature five ratios offering a wide speed range to choose from. The large version offers three ratios with excellent torque performance.

Typical Applications

- Servo X-Y-Z Axes
- Robotics
- Semi Conductor
- General Purpose Applications
- Material Handling



(4) M3X0.5-6HX6.35mm(0.25in) DR MIN.
EQ SP ON 30mm(1.181in) DIA

Nx Series Performance Specifications

Model	NS362T-A12	NS362T-A25	NS362T-A50	NS362T-A100	NS362T-180
Ratio	12.5:1	25:1	50:1	100:1	180:1
Mating Motor Series	360	360	360	360	360
Maximum Speed (RPM)	400	200	100	50	27
Maximum Torque (Lb-In)	3.5	6	12	15.5	15.5
Maximum OHL (Over Hung Load)(Lb)	20	20	20	20	20
Maximum Thrust Load (Lb)	15	15	15	15	15

Model	NM240(2)T-A(B)6	NM240(2)T-A(B)12	NM240(2)T-A(B)50	NM240(2)T-A(B)100	NM240(2)T-A(B)180
Ratio	6:1	12.5:1	50:1	100:1	180:1
Mating Motor Series	240	240	240	240	240
Maximum Speed (RPM)	833 (500)	400 (240)	100 (60)	50 (30)	28 (16.6)
Maximum Torque (Lb-In)	6 (11)	12 (22)	43 (85)	78 (90)	90 (90)
Maximum OHL (Over Hung Load)(Lb)	25	25	25	25	25
Maximum Thrust Load (Lb)	15	15	15	15	15

Model	NL683T-C12	NL683T-C25	NL683T-C50
Ratio	12.5:1	25:1	50:1
Mating Motor Series	680	680	680
Maximum Speed (RPM)	180	80	40
Maximum Torque (Lb-In)	40	80	125
Maximum OHL (Over Hung Load)(Lb)	20	20	20
Maximum Thrust Load (Lb)	15	15	15

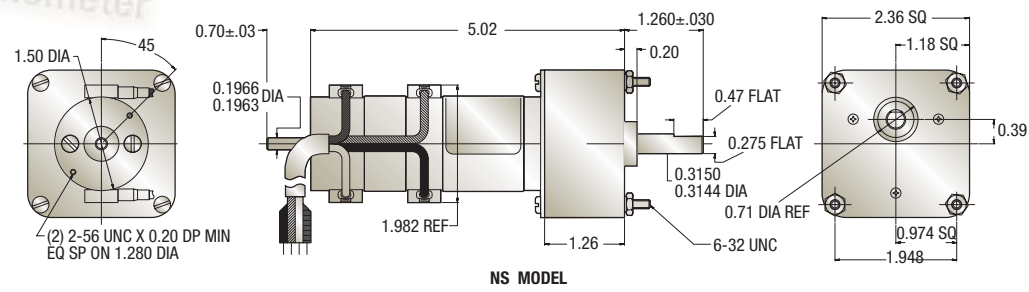
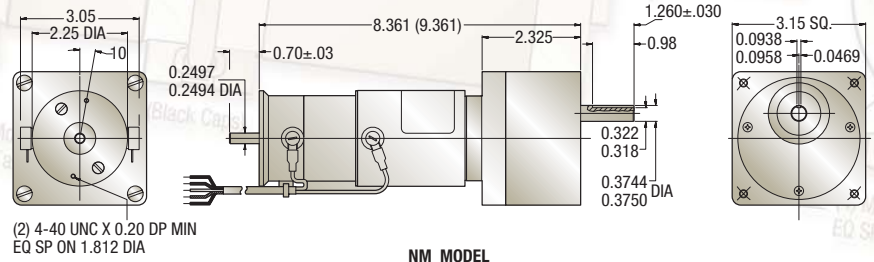
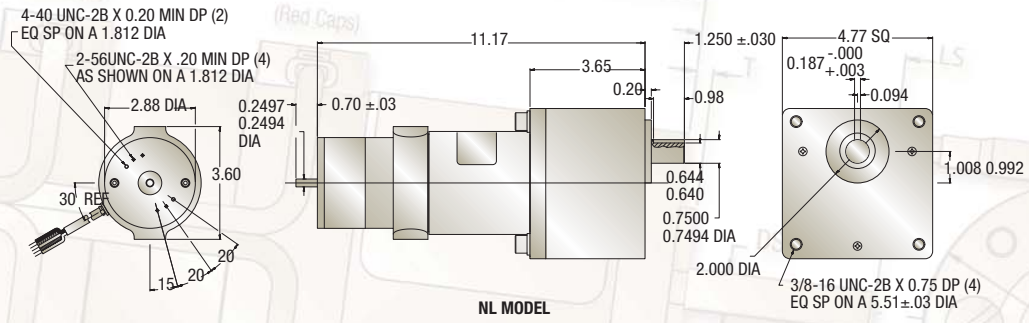

ElectroCraft Nx Series Model Designations

Nx360T – A12FL

Series- In-Line Gearbox

NS
NM
NL

Frame Designator

36 = 360 (1.50" Brush motor available with NS only)
24 = 240 (2.25" Brush motor available with NM only)
68 = 680 (3.25" Brush motor available with NL only)

Length Designator

0 – 9 see product pages

Tachometer Designator (omit if not applicable)

T = Tachometer

Winding Designator

A – Z, see product pages

Ratio Designator

6= 6:1
12= 12.5:1
50= 50:1
100= 100:1
180= 180:1

Lead Designator

F = Flying leads- see catalog if applicable
Z = Custom

Feedback Designator (omit if not applicable)

L = 500 line count
F = 1000 line count
H = 2000 line count
Z = custom
(standard offering: TTL logic with complements and un-gated index)

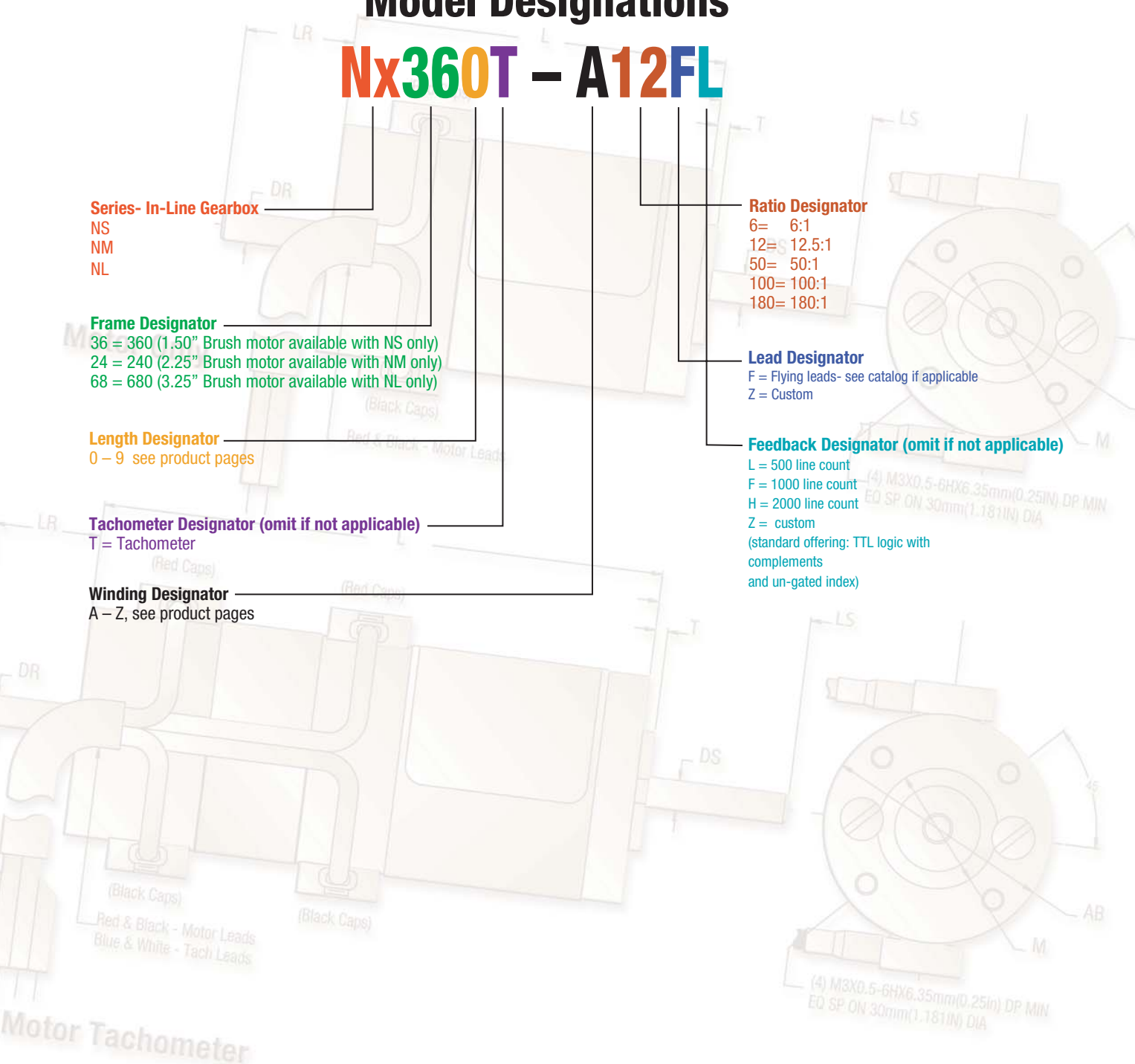

Nx Series Model Designations

Motor Only

Series- In-Line Gearbox

Frame Designator

Length Designator

Tachometer Designator (omit if not applicable)

Winding Designator

Ratio Designator

Lead Designator

Feedback Designator
(omit if not applicable)

Please explain any custom (Z) designators:

Please indicate any special features not covered in the model number:

ElectroCraft specializes in assisting you with an engineered solutions to meet your application needs. We also specialize in sourcing and assembling value added components to your assembly. Please contact your area sales representative (see world wide locations section) for assistance with your application needs.

Need a product fast?! ElectroCraft carries a limited supply of off-the-shelf model variations available for shipment within 48 hours. Please contact your area sales representative or our inside sales staff for a complete listing of stocked model numbers and pricing sheet.

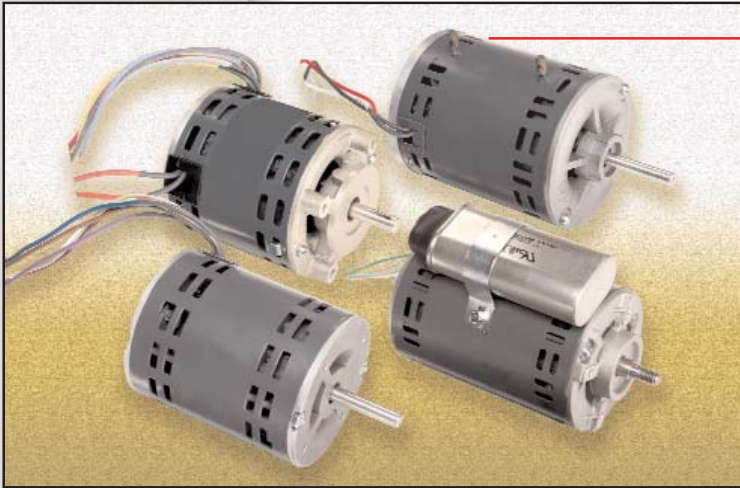

AC Motor Series

ElectroCraft AC Motor Series

The AC product offers a wide choice of electrical types (see performance tables) with standard or customized mounting arrangements. ElectroCraft motors are engineered for versatility. Select from a wide range of head, shell and mounting configurations, as well as speeds and electrical types. These features, combined with our ability to produce output shafts with a variety of flats, keyways, splines, tapers, threads or cross holes, fit a variety of custom applications. ElectroCraft Engineered Solutions has a proven record of performance in applications requiring precise speed and torque control. Premium quality materials are used to offer top performance, quiet running and long life. The AC product meets or exceeds standards for materials, performance and safety established by Underwriters Laboratories and Canadian Standards Association.



of Leads
in Leads

(Black Caps)

(4) M3X0.5-6HX6.35mm(0.25m) DP MIN
EQ SP ON 30mm(1.181in) DIA

ster

AC Motor Types

Motor Types	HP Rating	Full Load Speeds (@ 60Hz)	Starting Torque	Breakdown Torque	Starting Current	Typical Characteristics
Permanent Split Capacitor (Type KP)	1/50 to 1/3	3250 1625	Low	Moderate	Low	Very compact, easy to maintain. High efficiency, high power factor. Can operate at several speeds with simple control devices. <i>Advantages:</i> Improved starting torque, quieter operation than split phase and provides frequent start/stop capability essential in many applications. <i>Disadvantage:</i> Performance is usually less satisfactory when starting. Changing the capacitor value will affect both starting and running conditions, so that any improvements in starting will usually result in a decrease in running performance.
Reluctance Synchronous Split Capacitor (Type SKP)	1/50 to 1/6	1800	Low	Moderate	Low	Same as Type KP, but used where constant speed is essential.
Capacitor Start (Type KL)	1/80 to 1/6	3450 1725	High	High	Moderate	Suitable for constant speed under varying load, high torques, high overload capacity. With the Type KP motor, a capacitor is added in "series" with the start winding during the start mode to increase starting torque and/or reduce starting current. The start winding and capacitor will be disconnected when the motor has reached approximately 70% of running speed. Since the "run" winding alone has no starting capability, both starting and running windings are energized while starting.
Reluctance Synchronous Capacitor Start (Type SKL)	1/30 to 1/3	3600 1800	High	High	Moderate	Same as Type KL, but used where constant speed is essential.
Polyphase (or 3-Phase) (Type L)	1/30 to 1/3	3420 1710	High	High	Moderate	Generally suited to same applications as capacitor start motors if polyphase power is available. Reaches operating speed smoothly and quickly. Very efficient design.

Type KP

Permanent Split Capacitor

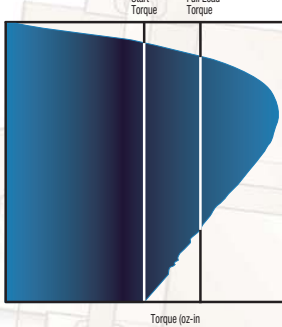

Type KL

Capacitor Start

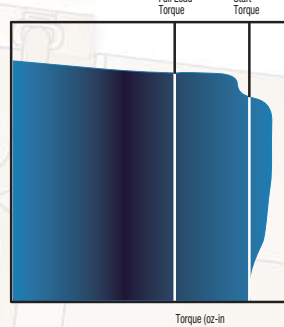

Type L

Polyphase

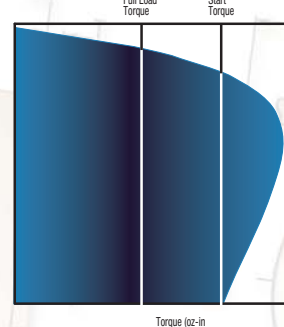

Type L, SL

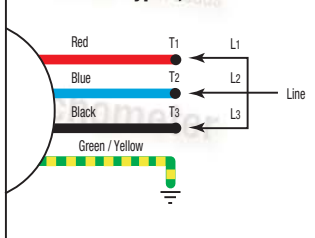

Type KP, SKP

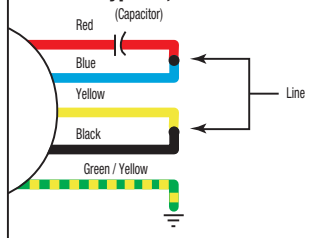

Type KL, SKL

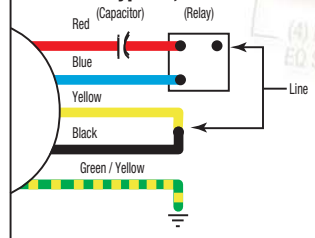

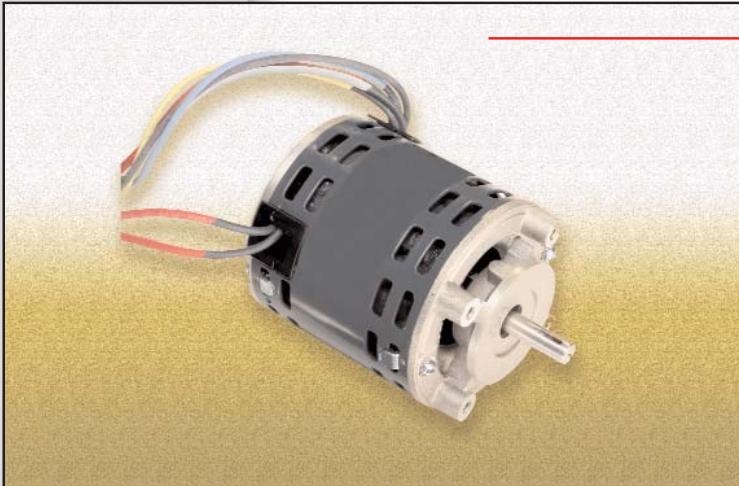

AC26 Motor Series

Features and Benefits

- Die cast aluminum rotor end rings and bars with integral cooling fans. Aluminum alloy selected to match performance to job requirements. Skewed rotor bars promote uniform torque, quiet running.
- Annealed laminations in stator and rotor keep efficiency high for cooler operation.
- Stator windings scientifically designed and computer matched to customer's requirements to assume maximum energy efficiency.
- Rotors are dynamically balanced to assure low vibration.
- Die cast aluminum end caps with precision machined fits assure uniform air gap, firm bearing support for quiet running, long life.
- Double-shielded or sealed ball bearings are greased for life with rust inhibiting grease; no periodic service needed.
- Durable Class B or Class F insulation system to meet UL and CSA standards.
- Thermal protector available to guard against accidental stalls or jams and prevent burnout.

Typical Applications

- Valve Actuators
- Blowers
- Pumps
- Office Equipment/Business Machines
- Medical Equipment
- Hoists
- Food Products Machinery

Options

Electrical: Class B insulation - UL and CSA Listed • Class F insulation - UL and CSA Listed • Choice of lead material, insulation thickness, gauge and length • Choice of lead combinations - tinned copper, spade, pin or lug terminals, plugs • Cord sets with or without plug ends or inline switches • Oil immersion insulation system • Relay and capacitor supplied (where necessary) • 50/60 Hz combined rating • Multiple voltage ratings.

Mechanical: Capacitor or relay cover shell mounted • Double shaft extensions • Special shaft configurations: Gear involutes, splines, external and internal threads, keyways, multiple flats, ring grooves, cross holes, screwdriver slots, multiple diameters, tapers • Totally enclosed configurations • Weld studs • Choice of shaft material.



(4) M3X0.5-6HX6.35mm(0.25m) DP MIN.
EQ SP OR 30mm(1.181in) DIA

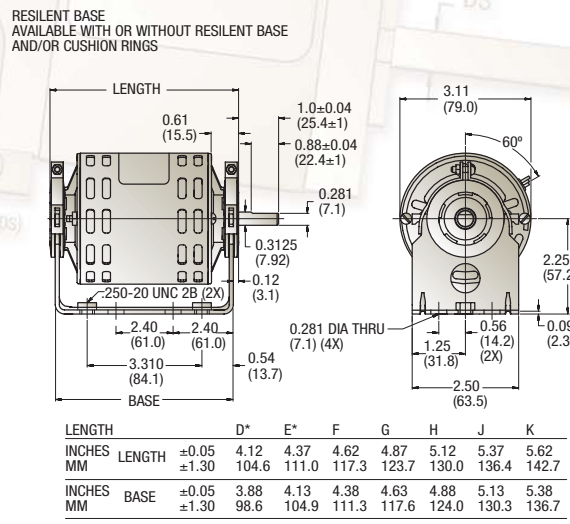
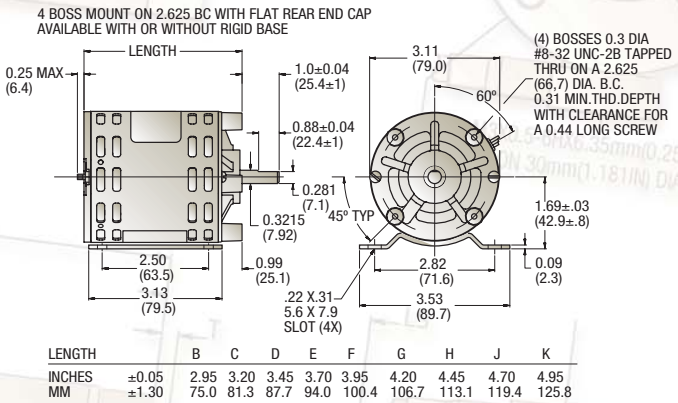
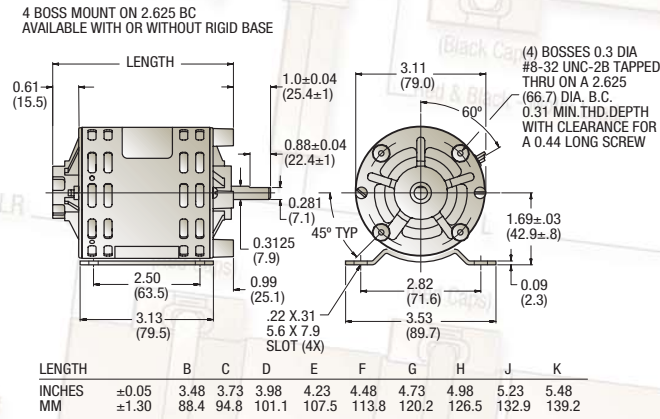
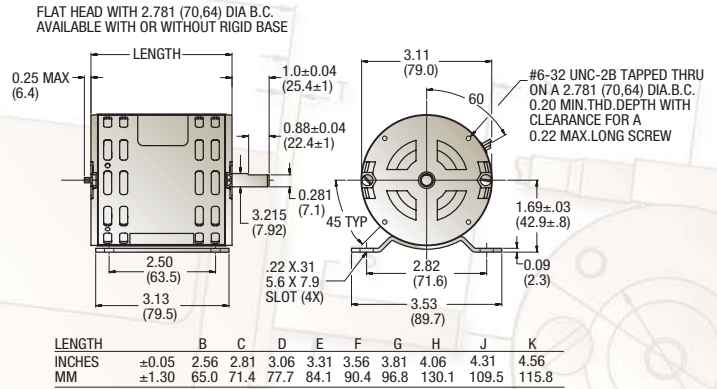
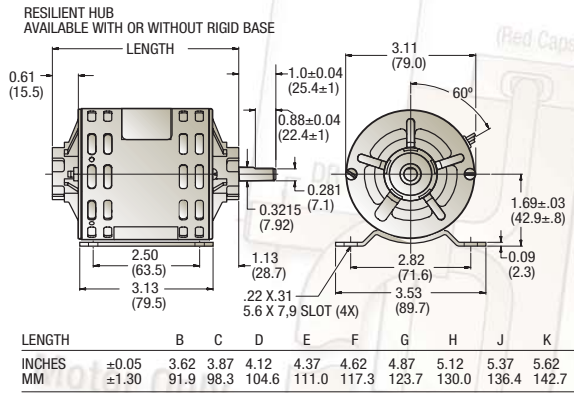

* 0.250-20 UNC-2B NOT AVAILABLE

26 Frame AC Motor Series Performance Specifications

Motor Types	Poles	Performance Designator	Length	Voltage	Frequency	Rated Load					Maximum Torque	Starting		Capacitor	
						HP Rating	Amps	Watts	Speed	Torque		Amps	Torque	Mfd.	Vac
KP	2	05	C	115	60	1/50	0.4	39	3385	6.0	13.0	0.8	4.6	3.0	236
KP	2	06	C	115	60	1/40	0.5	44	3300	7.7	15.0	0.9	4.2	3.0	236
KP	2	07	D	115	60	1/30	0.5	51	3370	10.0	18.0	1.2	5.5	3.0	236
KP	2	08	E	115	60	1/25	0.5	56	3380	12.0	23.0	1.4	6.7	4.0	236
KP	2	09	E	115	60	1/20	0.6	70	3370	15.1	27.0	1.7	8.2	5.0	236
KP	2	10	F	115	60	1/15	0.8	87	3390	20.0	35.1	2.5	10.3	5.0	218
KP	2	11	G	115	60	1/12	1.0	107	3390	25.1	49.0	2.9	13.6	6.0	236
KP	2	12	H	115	60	1/10	1.3	130	3360	30.3	60.0	3.7	17.6	6.0	236
KP	4	04	D	115	60	1/60	0.3	35	1620	10.5	19.0	0.6	10.0	3.0	236
KP	4	05	D	115	60	1/50	0.4	46	1630	12.5	24.0	0.6	17.4	4.0	236
KP	4	06	E	115	60	1/40	0.5	46	1625	15.4	29.0	0.9	14.0	4.0	236
KP	4	07	F	115	60	1/30	0.5	50	1670	20.7	37.9	1.1	18.8	4.0	236
KP	4	08	G	115	60	1/25	0.6	67	1625	25.1	47.0	1.3	24.0	5.0	236
KP	4	09	H	115	60	1/20	0.8	83	1630	31.2	60.0	1.7	30.0	6.0	236
KP	4	10	K	115	60	1/15	1.0	88	1660	40.0	78.0	2.5	31.2	6.0	236
KP	2	05	C	220	50	1/50	0.3	52	2700	7.5	12.0	0.4	4.0	3.0	220
KP	2	06	C	220	50	1/40	0.3	65	2555	9.8	12.8	0.5	3.5	3.0	220
KP	2	07	D	220	50	1/30	0.6	65	2710	12.4	18.0	0.6	4.8	3.0	220
KP	2	08	E	220	50	1/25	0.4	67	2765	14.7	24.0	0.8	6.1	4.0	220
KP	2	09	E	220	50	1/20	0.5	89	2720	18.8	27.0	0.9	7.0	5.0	220
KP	2	10	F	220	50	1/15	0.4	108	2740	25.0	38.0	1.3	9.0	5.0	220
KP	2	11	G	220	50	1/12	0.5	121	2780	30.1	51.0	1.5	12.0	1.5	440
KP	2	12	H	220	50	1/10	0.7	161	2785	37.0	62.0	1.9	15.0	1.5	440
KP	4	04	D	220	50	1/60	0.2	42	1250	13.2	18.0	0.3	8.6	3.0	370
KP	4	05	D	220	50	1/50	0.3	55	1230	16.1	21.5	0.4	10.0	3.0	370
KP	4	06	E	220	50	1/40	0.3	58	1260	19.8	28.0	0.5	12.0	3.0	370
KP	4	07	F	220	50	1/30	0.4	72	1255	26.1	35.0	0.6	16.0	4.0	370
KP	4	08	G	220	50	1/25	0.5	82	1270	31.4	47.0	0.7	20.0	5.0	440
KP	4	09	H	220	50	1/20	0.6	99	1280	37.5	57.0	0.9	25.0	1.5	370
KP	4	10	K	220	50	1/15	0.8	124	1275	50.0	74.0	1.2	29.0	1.5	370

All torque values are in ounce-inches. KP=Permanent Split Capacitor; KL=Capacitor Start; L=Polyphase. Other motor types not shown here: SKP=Synchronous Permanent Split Capacitor; SKL=Synchronous Capacitor Start

These 3.11 inch diameter motors are the smallest ElectroCraft Engineered Solutions offers and are designed for continuous duty in a 40°C ambient temperature. At nominal 1650 or 3450 rpm, ratings range from 1/150 to 1/10 HP (contact your area sales representative for intermittent ratings, higher ambient, or TENV construction). Motor specifications based on theoretical values for reference only.

26 Frame AC Motor Series Performance Specifications

Motor Types	Poles	Performance Designator	Length	Voltage	Frequency	Rated Load					Maximum Torque	Starting		Capacitor	
						HP Rating	Amps	Watts	Speed	Torque		Amps	Torque	Mfd.	Vac
KL	2	06	D	115	60	1/40	0.8	59	3425	7.4	15.0	2.5	19.0	36.0	110
KL	2	07	E	115	60	1/30	0.8	61	3435	9.7	21.0	2.9	25.0	43.0	110
KL	2	08	E	115	60	1/25	1.0	80	3425	11.9	24.0	3.5	30.0	43.0	110
KL	4	05	E	115	60	1/50	0.6	42	1695	11.9	19.5	2.0	24.0	43.0	125
KL	4	06	F	115	60	1/40	0.6	48	1685	15.0	21.5	2.2	30.0	47.0	125
KL	4	07	G	115	60	1/30	0.8	60	1690	19.9	29.5	2.6	41.0	53.0	125
KL	4	08	H	115	60	1/25	0.9	68	1695	23.8	37.5	3.0	51.0	64.0	125
KL	4	09	J	115	60	1/20	1.1	87	1685	29.9	43.5	3.6	61.0	72.0	125
KL	2	06	D	220	50	1/40	0.5	83	2800	8.9	16.0	1.8	28.0	21.0	165
KL	2	07	E	220	50	1/30	0.5	78	2830	11.7	23.0	2.0	39.0	21.0	165
KL	2	08	E	220	50	1/25	0.7	109	2810	14.3	25.0	2.1	36.0	21.0	165
KL	2	09	F	220	50	1/20	0.7	107	2830	17.8	35.0	2.4	49.0	21.0	165
KL	2	10	G	220	50	1/15	0.9	143	2825	23.4	41.0	2.7	53.0	21.0	165
KL	2	11	H	220	50	1/12	1.1	161	2830	29.6	55.0	3.2	61.0	21.0	165
KL	2	12	J	220	50	1/10	1.2	185	2820	35.6	60.0	3.4	75.0	30.0	220
KL	4	05	E	220	50	1/50	0.4	64	1345	15.0	20.0	0.9	16.0	43.0	110
KL	4	06	F	220	50	1/40	0.4	68	1345	18.5	23.0	1.0	19.0	47.0	110
KL	4	07	G	220	50	1/30	0.6	85	1350	24.0	32.0	1.3	30.0	53.0	110
KL	4	08	H	220	50	1/25	0.6	92	1370	29.0	42.0	1.7	62.0	21.0	220
KL	4	09	J	220	50	1/20	0.8	122	1350	36.6	47.0	1.8	64.0	21.0	220
L	4	06	E	230	60	1/40	0.2	34	1715	15.0	45.6	0.5	35.5	-	-
L	4	07	G	230	60	1/30	0.3	46	1735	20.0	84.6	1.0	72.2	-	-
L	4	12	K	230	60	1/10	0.4	120	1650	60.8	140.0	0.9	120.0	-	-
L	4	13	L	230	60	1/8	0.5	142	1670	74.0	170.0	1.7	137.0	-	-

All torque values are in ounce-inches. KP=Permanent Split Capacitor; KL=Capacitor Start; L=Polyphase. Other motor types not shown here: SKP=Synchronous Permanent Split Capacitor; SKL=Synchronous Capacitor Start

These 3.11 inch diameter motors are the smallest ElectroCraft Engineered Solutions offers and are designed for continuous duty in a 40°C ambient temperature. At nominal 1650 or 3450 rpm, ratings range from 1/150 to 1/10 HP (contact your area sales representative for intermittent ratings, higher ambient, or TENV construction). Motor specifications based on theoretical values for reference only.

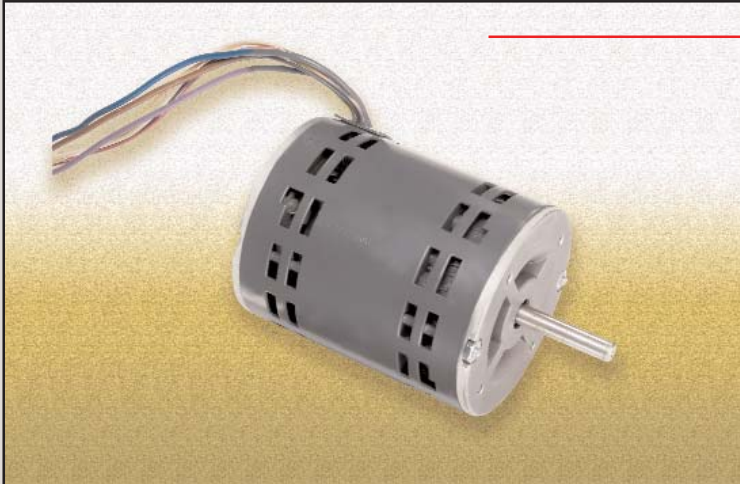

AC29 Motor Series

Features and Benefits

- Die cast aluminum rotor end rings and bars with integral cooling fans. Aluminum alloy selected to match performance to job requirements. Skewed rotor bars promote uniform torque, quiet running.
- Annealed laminations in stator and rotor keep efficiency high for cooler operation.
- Stator windings scientifically designed and computer matched to customer's requirements to assume maximum energy efficiency.
- Rotors are dynamically balanced to assure low vibration.
- Die cast aluminum end caps with precision machined fits assure uniform air gap, firm bearing support for quiet running, long life.
- Double-shielded or sealed ball bearings are greased for life with rust inhibiting grease; no periodic service needed.
- Durable Class B or Class F insulation system to meet UL and CSA standards.
- Thermal protector available to guard against accidental stalls or jams and prevent burnout.

Typical Applications

- Valve Actuators
- Blowers
- Pumps
- Office Equipment/Business Machines
- Medical Equipment
- Hoists
- Food Products Machinery

Options

Electrical: Class B insulation - UL and CSA Listed • Class F insulation - UL and CSA Listed • Choice of lead material, insulation thickness, gauge and length • Choice of lead combinations - tinned copper, spade, pin or lug terminals, plugs • Cord sets with or without plug ends or inline switches • Oil immersion insulation system • Relay and capacitor supplied (where necessary) • 50/60 Hz combined rating • Multiple voltage ratings.

Mechanical: Capacitor or relay cover shell mounted • Double shaft extensions • Special shaft configurations: Gear involutes, splines, external and internal threads, keyways, multiple flats, ring grooves, cross holes, screwdriver slots, multiple diameters, tapers • Totally enclosed configurations • Weld studs • Choice of shaft material.



FLAT HEADS BOTH ENDS
 AVAILABLE WITH OR WITHOUT RIGID BASE

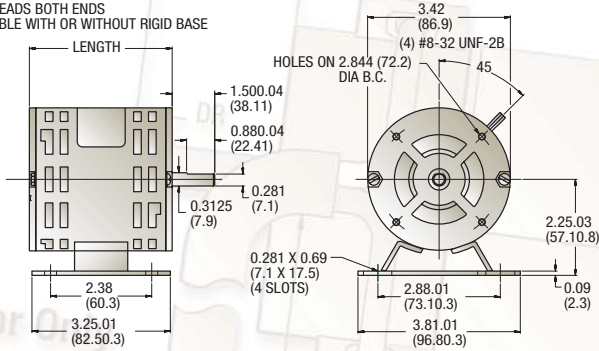

LENGTH	C	D	E	F	G	H	J	K	L	M	N	P	
INCHES	0.05	2.853	3.103	3.353	3.603	3.853	4.103	4.353	4.603	4.853	5.103	5.353	5.603
MM	1.30	72.5	78.8	85.2	91.5	97.9	104.2	110.6	116.9	123.3	129.6	136.0	142.3

4 STUD, FACE MOUNT
 AVAILABLE WITH OR WITHOUT RIGID BASE

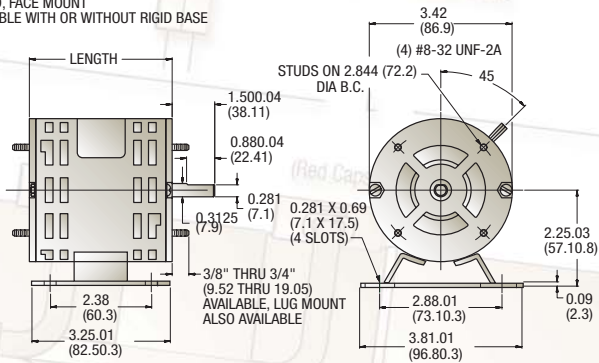

LENGTH	C	D	E	F	G	H	J	K	L	M	N	P	
INCHES	0.05	2.853	3.103	3.353	3.603	3.853	4.103	4.353	4.603	4.853	5.103	5.353	5.603
MM	1.30	72.5	78.8	85.2	91.5	97.9	104.2	110.6	116.9	123.3	129.6	136.0	142.3

(4) M3X0.5-6HX6.35mm(0.25IN) DP MIN
 EQ SP ON 30mm(1.181IN) DIA

(Black Caps)
 Red & Black - Motor Leads
 Blue & White - Tach Leads

(4) M3X0.5-6HX6.35mm(0.25in) DP MIN
 EQ SP ON 30mm(1.181IN) DIA

Motor Tachometer

29 Frame AC Motor Series Performance Specifications

Motor Types	Poles	Performance Designator	Length	Voltage	Frequency	Rated Load					Maximum Torque	Starting		Capacitor	
						HP Rating	Amps	Watts	Speed	Torque		Amps	Torque	Mfd.	Vac
KP	2	09	E	115	60	1/20	0.9	92	3400	15.0	30	2.0	11.0	5.0	330
KP	2	10	F	115	60	1/15	1.0	111	3440	20.0	35	2.2	12.0	6.0	330
KP	2	12	G	115	60	1/10	1.3	143	3430	29.0	56	3.5	17.0	7.5	330
KP	2	13	H	115	60	1/8	1.8	173	3445	37.0	75	5.2	18.0	7.5	330
KP	2	14	J	115	60	1/6	1.9	215	3450	49.0	104	6.5	29.0	10.0	330
KP	2	15	K	115	60	1/5	2.1	236	3435	60.0	115	7.2	30.0	15.0	330
KP	2	16	L	115	60	1/4	2.3	266	3420	74.0	147	9.0	36.0	15.0	330
KP	4	08	F	115	60	1/25	0.9	82	1630	24.0	40	1.5	26.0	4.0	330
KP	4	09	H	115	60	1/20	1.0	90	1670	29.0	72	2.3	32.0	6.0	330
KP	4	10	J	115	60	1/15	1.3	117	1680	39.0	79	2.7	32.0	7.5	330
KP	4	11	K	115	60	1/12	1.3	127	1675	49.0	100	3.1	44.0	10.0	330
KP	4	12	M	115	60	1/10	1.3	133	1650	60.0	121	3.1	61.0	12.0	330
KP	4	13	P	115	60	1/8	1.4	157	1655	76.0	156	3.9	71.0	15.0	330
KP	2	09	E	220	50	1/20	0.8	87	2730	17.8	27	1.4	13.0	7.0	250
KP	2	10	F	220	50	1/15	0.8	96	2765	23.8	38	1.8	16.0	9.0	250
KP	2	12	G	220	50	1/10	1.2	128	2765	35.2	56	2.8	20.0	9.0	250
KP	2	13	H	220	50	1/8	1.5	166	2810	43.8	80	4.1	26.0	10.0	250
KP	2	14	J	220	50	1/6	1.8	204	2800	58.8	106	5.2	35.0	15.0	250
KP	2	15	K	220	50	1/5	2.2	235	2805	70.8	140	6.9	40.0	17.5	250
KP	2	16	M	220	50	1/4	2.4	270	2790	90.0	154	7.3	47.0	20.0	280
KP	4	08	F	220	50	1/25	0.5	55	1220	28.2	36	0.8	24.0	6.0	220
KP	4	09	H	220	50	1/20	0.6	78	1325	34.8	59	1.2	36.0	8.0	220
KP	4	10	J	220	50	1/15	0.8	93	1315	46.8	76	1.6	42.0	10.0	220
KP	4	11	K	220	50	1/12	1.0	90	1310	58.8	93	1.9	52.0	12.0	220
KP	4	12	M	220	50	1/10	1.1	120	1330	72.0	122	2.5	68.0	12.5	220
KP	4	13	P	220	50	1/8	1.5	145	1290	105.6	151	3.1	79.0	15.0	220

All torque values are in ounce-inches. KP=Permanent Split Capacitor; KL=Capacitor Start; L=Polyphase. Other motor types not shown here: SKP=Synchronous Permanent Split Capacitor; SKL=Synchronous Capacitor Start

These 3.42 inch diameter motors are designed for continuous duty in a 40°C ambient temperature. At nominal 1650 or 3450 rpm, ratings range from 1/60 to 1/4 HP (contact your area sales representative for intermittent ratings, higher ambient, or TENV construction). Motor specifications based on theoretical values for reference only.

Red & Black - Motor Leads
 Blue & White - Tach Leads

(Black Caps)

(4) M3X0.5-6HX6.35mm(D.25in) DP MIN
 EQ SP ON 30mm(1.181in) DIA

Motor Tachometer

29 Frame AC Motor Series Performance Specifications

Motor Types	Poles	Performance Designator	Length	Voltage	Frequency	Rated Load					Maximum Torque	Starting		Capacitor	
						HP Rating	Amps	Watts	Speed	Torque		Amps	Torque	Mfd.	Vac
KL	2	08	F	115	60	1/25	1.1	80	3440	12.0	30	3.1	24.0	36.0	110
KL	2	10	G	115	60	1/15	1.7	124	3450	20.0	49	5.0	40.0	36.0	110
KL	2	11	H	115	60	1/12	1.8	126	3445	25.0	61	5.6	49.0	43.0	110
KL	2	13	K	115	60	1/8	2.3	172	3460	37.0	101	8.6	74.0	53.0	110
KL	2	14	M	115	60	1/6	2.8	218	3490	50.0	127	11.0	98.0	53.0	110
KL	2	15	N	115	60	1/5	3.0	247	3465	60.0	141	11.7	117.0	75.0	110
KL	2	16	P	115	60	1/4	3.6	296	3460	74.0	168	13.7	126.0	75.0	110
KL	4	06	G	115	60	1/40	1.4	93	1670	15.0	40	2.4	33.0	36.0	110
KL	4	07	H	115	60	1/30	1.4	91	1680	20.0	52	2.7	42.0	36.0	110
KL	4	08	J	115	60	1/25	1.5	98	1680	24.0	59	3.0	52.0	36.0	110
KL	4	09	K	115	60	1/20	1.8	115	1685	31.0	76	3.6	66.0	43.0	110
KL	4	11	M	115	60	1/12	2.1	149	1675	51.0	98	4.7	108.0	43.0	110
KL	2	08	F	220	50	1/25	1.1	81	2810	14.4	29	2.8	29.0	36.0	120
KL	2	10	G	220	50	1/15	1.5	121	2795	24.0	42	3.6	42.0	36.0	120
KL	2	11	H	220	50	1/12	1.5	128	2790	30.0	50	4.0	42.0	36.0	120
KL	2	13	K	220	50	1/8	2.0	175	2800	44.4	76	6.0	70.0	36.0	120
KL	2	14	M	220	50	1/6	2.5	216	2795	60.0	103	7.6	87.0	43.0	120
KL	2	15	N	220	50	1/5	2.7	255	2750	72.0	106	8.0	105.0	47.0	120
KL	2	16	P	220	50	1/4	3.2	295	2755	87.6	134	9.6	122.0	53.0	120
KL	4	06	G	220	50	1/40	1.0	78	1310	18.6	29	2.2	52.0	36.0	120
KL	4	07	H	220	50	1/30	1.2	93	1330	24.0	40	2.7	62.0	36.0	120
KL	4	08	J	220	50	1/25	1.2	90	1330	29.4	47	2.7	69.0	36.0	120
KL	4	09	K	220	50	1/20	1.7	120	1340	37.2	65	3.4	83.0	36.0	120
KL	4	11	M	220	50	1/12	1.7	145	1260	61.0	73	3.4	101.0	36.0	120
L	2	12	G	230	60	1/10	0.4	111	3420	29.0	110	2.2	116.0	-	-
L	2	13	H	230	60	1/8	0.5	131	3420	37.0	146	2.9	160.0	-	-
L	2	14	J	230	60	1/6	0.6	174	3420	49.0	191	3.8	200.0	-	-
L	2	15	K	230	60	1/5	0.8	204	3420	59.0	258	4.9	290.0	-	-
L	2	16	L	230	60	1/4	0.9	250	3420	74.0	314	5.9	356.0	-	-
L	2	17	M	230	60	1/3	1.3	340	3420	98.0	416	8.0	475.0	-	-
L	4	08	G	230	60	1/25	0.5	81	1710	23.5	164	1.5	190.0	-	-
L	4	09	H	230	60	1/20	0.6	89	1710	30.0	197	1.8	227.0	-	-
L	4	10	J	230	60	1/15	0.8	114	1710	39.0	272	2.4	312.0	-	-
L	4	11	K	230	60	1/12	0.9	132	1705	49.0	322	2.8	368.0	-	-
L	4	12	M	230	60	1/10	0.9	142	1705	59.0	347	3.1	395.0	-	-
L	4	13	P	230	60	1/8	1.1	173	1700	73.0	445	3.8	510.0	-	-

All torque values are in ounce-inches. KP=Permanent Split Capacitor; KL=Capacitor Start; L=Polyphase. Other motor types not shown here: SKP=Synchronous Permanent Split Capacitor; SKL=Synchronous Capacitor Start

These 3.42 inch diameter motors are designed for continuous duty in a 40°C ambient temperature. At nominal 1650 or 3450 rpm, ratings range from 1/60 to 1/4 HP (contact your area sales representative for intermittent ratings, higher ambient, or TENV construction). Motor specifications based on theoretical values for reference only.

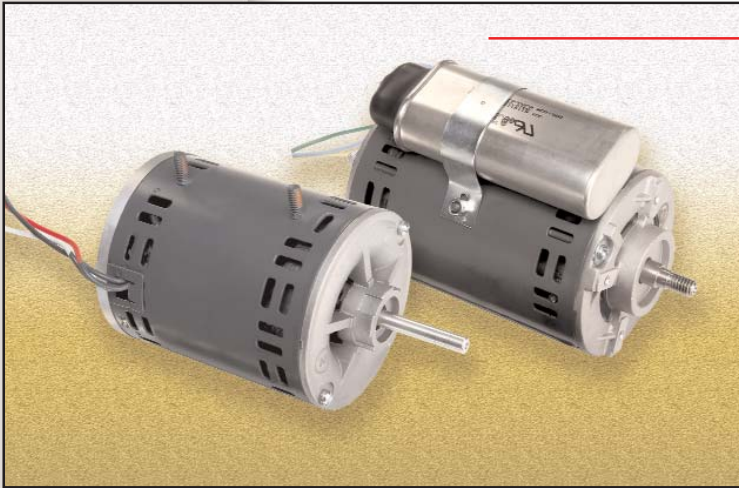

AC33 Motor Series

Features and Benefits

- Die cast aluminum rotor end rings and bars with integral cooling fans. Aluminum alloy selected to match performance to job requirements. Skewed rotor bars promote uniform torque, quiet running.
- Annealed laminations in stator and rotor keep efficiency high for cooler operation.
- Stator windings scientifically designed and computer matched to customer's requirements to assume maximum energy efficiency.
- Rotors are dynamically balanced to assure low vibration.
- Die cast aluminum end caps with precision machined fits assure uniform air gap, firm bearing support for quiet running, long life.
- Double-shielded or sealed ball bearings are greased for life with rust inhibiting grease; no periodic service needed.
- Durable Class B or Class F insulation system to meet UL and CSA standards.
- Thermal protector available to guard against accidental stalls or jams and prevent burnout.

Typical Applications

- Valve Actuators
- Blowers
- Pumps
- Office Equipment/Business Machines
- Medical Equipment
- Hoists
- Food Products Machinery

Options

Electrical: Class B insulation - UL and CSA Listed • Class F insulation - UL and CSA Listed • Choice of lead material, insulation thickness, gauge and length • Choice of lead combinations - tinned copper, spade, pin or lug terminals, plugs • Cord sets with or without plug ends or inline switches • Oil immersion insulation system • Relay and capacitor supplied (where necessary) • 50/60 Hz combined rating • Multiple voltage ratings.

Mechanical: Capacitor or relay cover shell mounted • Double shaft extensions • Special shaft configurations: Gear involutes, splines, external and internal threads, keyways, multiple flats, ring grooves, cross holes, screwdriver slots, multiple diameters, tapers • Totally enclosed or totally enclosed fan cooled configurations • Weld studs • Choice of shaft material.



(4) M3X0.5-6HX6.35mm(0.25in) DP MIN.
EQ SP ON 30mm(1.181in) DIA

4 BOSS MOUNT ON 1.75 BC
 AVAILABLE WITH OR WITHOUT RIGID BASE

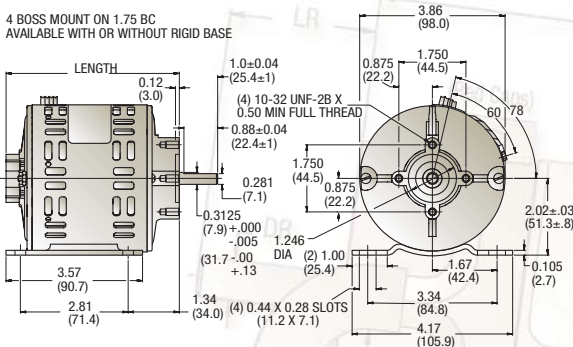

LENGTH	E	F	G	H	J	K	L	M	N	P	
INCHES	±0.05	4.49	4.74	4.99	5.24	5.49	5.74	5.99	6.24	6.49	6.74
MM	±1.30	114.0	120.4	126.7	133.1	139.4	145.8	152.1	158.5	164.8	171.2

RESILIENT BASE
 AVAILABLE WITH OR WITHOUT RESILIENT BASE
 AND/OR CUSHION RINGS

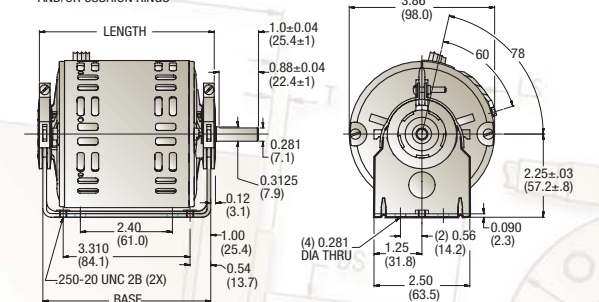

LENGTH	E	F	G	H	J	K	L	M	N	P	
INCHES	±0.05	4.30	4.55	4.80	5.05	5.30	5.55	5.80	6.05	6.30	6.55
MM	±1.30	109.2	115.6	121.9	128.3	134.6	141.0	147.3	153.7	160.0	166.4
INCHES	±0.05	4.04	4.29	4.54	4.79	5.04	5.29	5.54	5.79	6.04	6.29
MM	±1.30	102.6	109.0	115.3	121.7	128.0	134.4	140.7	147.1	153.4	159.8

PUMP MOUNT
 AVAILABLE WITH OR WITHOUT RIGID BASE

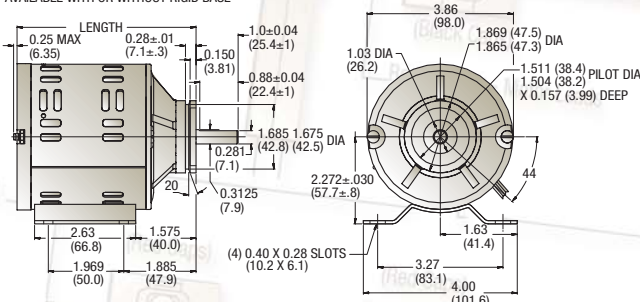

LENGTH	E	F	G	H	J	K	L	M	N	P	
INCHES	±0.05	4.71	4.96	5.21	5.46	5.71	5.96	6.21	6.46	6.71	6.96
MM	±1.30	119.6	126.0	132.3	138.7	145.0	151.4	157.7	164.1	170.4	176.8

RESILIENT HUB
 AVAILABLE WITH OR WITHOUT RIGID BASE

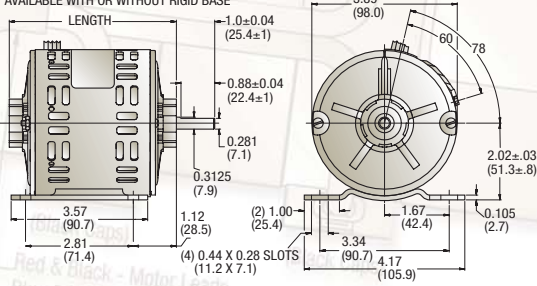

LENGTH	E	F	G	H	J	K	L	M	N	P	
INCHES	±0.05	4.30	4.55	4.80	5.05	5.30	5.55	5.80	6.05	6.30	6.55
MM	±1.30	109.2	115.6	121.9	128.1	134.6	141.0	147.3	153.7	160.0	166.4

4 BOSS MOUNT ON 2.844 BC
 AVAILABLE WITH OR WITHOUT RIGID BASE

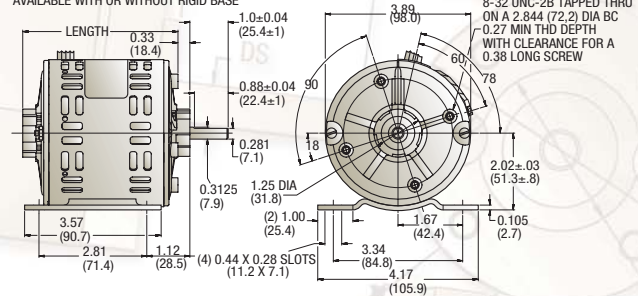

LENGTH	E	F	G	H	J	K	L	M	N	P	
INCHES	±0.05	4.01	4.26	4.51	4.76	5.01	5.26	5.51	5.76	6.01	6.26
MM	±1.30	101.9	108.2	114.6	120.9	127.3	133.6	140.0	146.3	152.7	159.0

4 BOSS MOUNT ON 2.844 BC (2.625 THRU 3.125)
 AVAILABLE WITH OR WITHOUT RIGID BASE

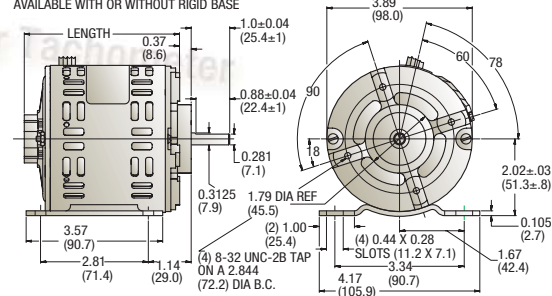

LENGTH	E	F	G	H	J	K	L	M	N	P	
INCHES	±0.05	4.13	4.38	4.63	4.88	5.13	5.38	5.63	5.88	6.13	6.38
MM	±1.30	104.9	111.3	117.6	124.0	130.3	136.7	143.0	149.4	155.7	162.1

FLAT HEAD
 AVAILABLE WITH OR WITHOUT RIGID BASE

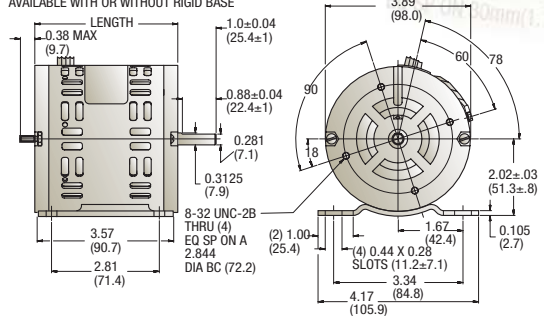

LENGTH	E	F	G	H	J	K	L	M	N	P	
INCHES	±0.05	3.77	4.02	4.27	4.52	4.77	5.02	5.27	5.52	5.77	6.02
MM	±1.30	95.8	102.1	108.5	114.8	121.2	127.5	133.9	140.2	146.6	152.9

33 Frame AC Motor Series Performance Specifications

Motor Types	Poles	Performance Designator	Lengh	Voltage	Frequency	Rated Load					Maximum Torque	Starting		Capacitor	
						HP Rating	Amps	Watts	Speed	Torque		Amps	Torque	Mfd.	Vac
KP	2	08	E	115	60	1/25	0.5	54	3460	12.0	21	1.3	5.0	6.0	236
KP	2	09	F	115	60	1/20	0.6	65	3490	14.8	31	1.9	6.0	7.5	236
KP	2	10	F	115	60	1/15	0.8	87	3470	20.0	35	2.0	8.4	10.0	236
KP	2	11	G	115	60	1/12	0.9	98	3495	37.8	45	2.9	9.6	12.0	236
KP	2	12	H	115	60	1/10	1.0	107	3495	41.2	56	3.6	10.4	12.0	236
KP	2	13	J	115	60	1/8	1.2	127	3485	49.2	70	4.6	9.8	12.0	236
KP	2	14	K	115	60	1/6	1.6	167	3480	65.2	84	5.7	11.9	15.0	236
KP	2	15	L	115	60	1/5	1.8	194	3490	75.2	111	7.2	16.7	20.0	236
KP	2	16	M	115	60	1/4	2.3	238	3485	92.4	140	9.4	17.0	20.0	236
KP	2	17	N	115	60	1/3	2.8	316	3450	99.0	186	12.7	24.3	25.0	236
KP	4	06	F	115	60	1/40	0.4	38	1730	14.8	26	0.7	8.9	5.0	236
KP	4	07	G	115	60	1/30	0.4	44	1730	19.7	34	1.0	11.3	6.0	236
KP	4	08	G	115	60	1/25	0.5	56	1730	23.7	39	1.0	14.2	7.5	236
KP	4	09	H	115	60	1/20	0.6	65	1730	29.6	50	1.3	16.5	9.0	236
KP	4	10	J	115	60	1/15	0.7	84	1740	39.3	71	2.0	22.4	12.0	236
KP	4	11	K	115	60	1/12	0.9	102	1735	48.9	91	2.6	28.5	15.0	236
KP	4	12	L	115	60	1/10	1.0	115	1740	58.9	108	3.1	28.4	15.0	236
KP	4	13	M	115	60	1/8	1.3	143	1735	73.5	125	3.6	36.8	20.0	236
KP	4	14	N	115	60	1/6	1.6	178	1725	97.2	171	3.7	44.7	25.0	236
KP	2	08	E	220	50	1/25	0.3	57	2855	14.4	22	0.6	4.1	1.5	370
KP	2	09	F	220	50	1/20	0.3	70	2900	17.8	33	1.0	5.8	2.0	370
KP	2	10	F	220	50	1/15	0.4	88	2870	24.0	36	1.1	7.5	2.5	370
KP	2	11	G	220	50	1/12	0.4	89	2915	24.0	47	1.5	8.0	3.0	370
KP	2	12	H	220	50	1/10	0.5	105	2900	36.3	62	1.8	11.0	4.0	370
KP	2	13	J	220	50	1/8	0.6	117	2890	44.4	69	2.2	7.8	3.0	370
KP	2	14	K	220	50	1/6	0.8	149	2885	60.0	78	2.5	9.4	4.0	370
KP	2	15	L	220	50	1/5	0.8	125	2890	72.0	75	2.3	9.3	5.0	370
KP	2	16	M	220	50	1/4	1.5	243	2900	90.0	136	4.4	16.9	5.0	370
KP	2	17	N	220	50	1/3	1.2	266	2850	120.0	152	3.8	32.7	10.0	370
KP	4	06	F	220	50	1/40	0.2	37	1430	17.8	31	0.4	7.7	1.3	370
KP	4	07	G	220	50	1/30	0.2	47	1430	23.6	44	0.6	10.0	1.5	370
KP	4	08	G	220	50	1/25	0.3	56	1430	28.4	50	0.7	13.0	2.0	370
KP	4	09	H	220	50	1/20	0.3	71	1440	35.5	75	0.9	24.0	2.5	440
KP	4	10	J	220	50	1/15	0.4	80	1455	35.5	96	1.4	21.0	3.0	370
KP	4	11	K	220	50	1/12	0.6	114	1440	58.8	130	1.8	30.0	4.0	370
KP	4	12	L	220	50	1/10	0.6	128	1430	72.0	150	2.1	30.0	4.0	370
KP	4	13	M	220	50	1/8	0.8	156	1430	90.0	166	2.4	34.1	5.0	370
KP	4	14	N	220	50	1/6	1.0	195	1425	120.0	199	2.9	38.1	6.0	370

All torque values are in ounce-inches. KP=Permanent Split Capacitor; KL=Capacitor Start; L=Polyphase. Other motor types not shown here: SKP=Synchronous Permanent Split Capacitor; SKL=Synchronous Capacitor Start

These 3.86 inch diameter motors are designed for continuous duty in a 40°C ambient temperature. At nominal 1650 or 3450 rpm, ratings range from 1/50 to 1/3 HP (contact your area sales representative for intermittent ratings, higher ambient, or TENV construction). Motor specifications based on theoretical values for reference only.

33 Frame AC Motor Series Performance Specifications

Motor Types	Poles	Performance Designator	Length	Voltage	Frequency	Rated Load					Maximum Torque	Starting		Capacitor	
						HP Rating	Amps	Watts	Speed	Torque		Amps	Torque	Mfd.	Vac
KL	2	09	F	115	60	1/20	1.0	80	3450	14.6	32	6.2	44.7	124.0	110
KL	2	10	G	115	60	1/15	1.1	92	3450	19.5	44	6.7	55.6	124.0	110
KL	2	11	H	115	60	1/12	1.3	107	3450	24.6	53	7.9	67.1	145.0	110
KL	2	12	J	115	60	1/10	1.5	123	3450	29.5	64	9.1	84.9	161.0	110
KL	2	13	K	115	60	1/8	1.6	148	3450	37.2	73	10.5	102.0	189.0	110
KL	4	12	M	115	60	1/10	0.6	128	1430	72.0	150	2.1	30.0	4.0	370
KL	4	13	N	115	60	1/8	0.8	165	1430	90.0	175	2.5	36.0	5.0	370
KL	4	14	P	115	60	1/6	1.2	225	1425	120.0	230	3.4	44.0	6.0	370
KL	2	09	F	220	50	1/20	0.7	99	2855	17.6	36	2.6	38.0	30.0	220
KL	2	10	G	220	50	1/15	0.8	108	2860	23.5	47	2.7	48.0	30.0	220
KL	2	11	H	220	50	1/12	0.8	120	2870	29.4	61	3.5	63.0	36.0	220
KL	2	12	J	220	50	1/10	0.9	135	2875	35.4	75	4.1	80.0	43.0	220
KL	2	13	K	220	50	1/8	1.0	155	2860	44.6	86	4.5	94.0	47.0	220
KL	2	14	L	220	50	1/6	1.4	200	2875	60.0	150	5.8	133.0	53.0	220
KL	4	10	K	220	50	1/15	1.0	123	1420	47.3	110	2.8	108.0	21.0	220
KL	4	11	L	220	50	1/12	1.1	150	1415	60.0	123	3.9	140.0	43.0	165
KL	4	12	M	220	50	1/10	1.2	162	1410	72.0	145	3.7	160.0	30.0	220
KL	4	13	N	220	50	1/8	1.6	200	1415	90.0	200	4.5	188.0	30.0	220
KL	4	14	P	220	50	1/6	1.9	265	1400	122.0	210	5.1	250.0	43.0	220
L	2	10	G	230	60	1/15	0.3	77	3425	19.7	64	0.5	64.5	-	-
L	2	11	H	230	60	1/12	0.3	90	3425	24.7	85	0.7	85.6	-	-
L	2	12	H	230	60	1/10	0.4	108	3420	29.5	96	1.1	92.5	-	-
L	2	13	J	230	60	1/8	0.4	128	3420	36.5	127	1.3	122.5	-	-
L	2	14	K	230	60	1/6	0.5	165	3415	48.9	175	2.1	166.8	-	-
L	2	15	L	230	60	1/5	0.5	199	3405	59.1	196	2.5	180.3	-	-
L	2	16	M	230	60	1/4	0.6	244	3420	73.7	276	3.7	258.2	-	-
L	2	17	M	230	60	1/3	0.9	326	3400	99.6	269	5.0	224.0	-	-
L	4	05	F	230	60	1/50	0.1	30	1705	11.8	50	0.5	46.0	-	-
L	4	06	F	230	60	1/40	0.2	36	1710	14.7	60	0.7	55.0	-	-
L	4	07	G	230	60	1/30	0.2	44	1710	19.6	82	0.9	75.0	-	-
L	4	08	H	230	60	1/25	0.2	53	1715	23.6	96	1.0	88.0	-	-
L	4	09	H	230	60	1/20	0.3	61	1710	29.5	121	1.2	112.0	-	-
L	4	10	J	230	60	1/15	0.3	76	1710	39.4	166	1.6	155.0	-	-
L	4	11	K	230	60	1/12	0.4	97	1715	49.3	204	2.1	191.0	-	-
L	4	12	L	230	60	1/10	0.4	109	1710	58.9	237	2.3	224.0	-	-
L	4	13	M	230	60	1/8	0.6	136	1720	74.0	267	2.9	237.0	-	-
L	4	14	N	230	60	1/6	0.7	168	1725	99.0	397	3.5	351.0	-	-

All torque values are in ounce-inches. Permanent Split Capacitor; KL=Capacitor Start; L=Polyphase. Other motor types not shown here: SKP=Synchronous Permanent Split Capacitor; SKL=Synchronous Capacitor Start

These 3.86 inch diameter motors are designed for continuous duty in a 40°C ambient temperature. At nominal 1650 or 3450 rpm, ratings range from 1/50 to 1/3 HP (contact your area sales representative for intermittent ratings, higher ambient, or TENV construction). Motor specifications based on theoretical values for reference only.

ElectroCraft AC Series Model Number Designations

KL33 - 084A - OSBSWF

Motor Type

- KL- Capacitor Start
- KP- Permanent Split Capacitor
- L- Polyphase
- SKP- Synchronous Split Capacitor
- SKL- Synchronous Capacitor Start

Frame Designator

- 26- 26 Frame (3.11 Diameter)
- 29- 29 Frame (3.42 Diameter)
- 33- 33 Frame (3.86 Diameter)

Performance Designator

- 26- 05-13 (see catalog)
- 29- 06-16 (see catalog)
- 33- 05-17 (see catalog)
- Z- Custom – consult factory

Speed Designator

- 2- 2 Pole
- 4- 4 Pole
- Z- Custom – consult factory for availability

Voltage Designator

- A- 115V – 60 Hz
- B- 220V – 50 Hz
- C- 230V – 60 Hz
- Z- Custom – consult factory

Enclosure Designator

- O- Open Ventilated (see catalog for performance details)
- V- TENV (consult factory for performance details)
- F- Fan Cooled (33 Frame only)

Shaft Configuration

- S- Standard (see catalog)
- Z- Custom – consult factory

Front Head Designator

- See catalog for details
- 26 Frame
 - S- Standard Flat Head – STD Tap
 - F- Four [4] Boss Mount on 2.625 B.C.
 - R- Resilient Hub
 - Z- Custom - consult factory

29 Frame

- S- Standard Flat Head – STD Tap
- F- Four [4] Stud Mount
- Z- Custom - consult factory

33 Frame

- S- Standard Flat Head – STD Tap
- F- Four [4] Boss Mount on 2.844 B.C.
- R- Resilient Hub
- B- Four [4] Boss Mount on 1.75 B.C.
- M- Four [4] Boss Mount on 2.625 thru 3.125 B.C.

P- Pump Mount

- Z- Custom - consult factory

Rear Head Designator

- See catalog for details
- S- Standard Flat Head
 - R- Resilient Hub (26, 33 Frames only)
 - Z- Custom - consult factory

Foot Mount (omit if not required)

- W- Rigid Base
- T- Resilient Base (26, 33 Frames only)

Lead Designator

- F- Flying leads
- J- Junction box (33 Frame only)
- Z- Custom – consult factory for terminals or connectors



AC Series Model Designations

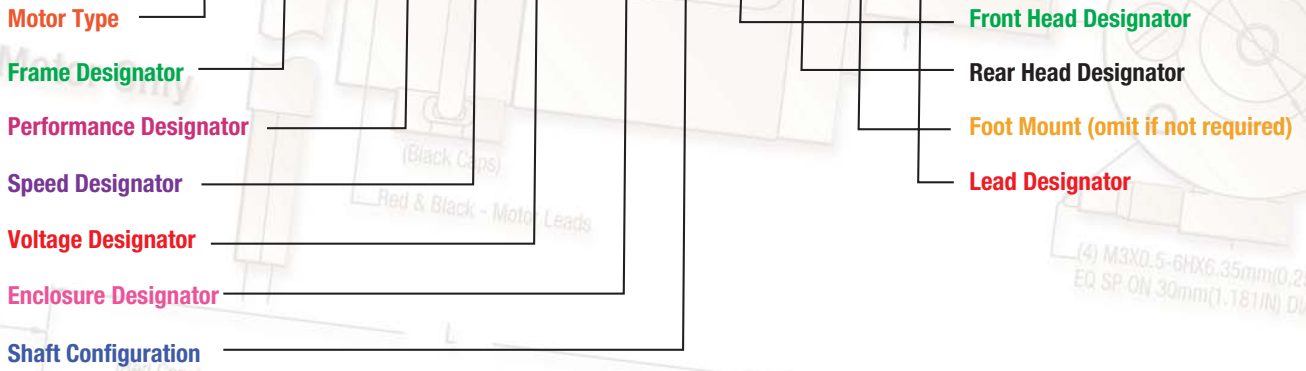

Please explain any custom (Z) designators:

Please indicate any special features not covered in the model number:

ElectroCraft specializes in assisting you with an engineered solutions to meet your application needs. We also specialize in sourcing and assembling value added components to your assembly. Please contact your area sales representative (see world wide locations section) for assistance with your application needs.

Need a product fast?! ElectroCraft carries a limited supply of off-the-shelf model variations available for shipment within 48 hours. Please contact your area sales representative or our inside sales staff for a complete listing of stocked model numbers and pricing sheet.

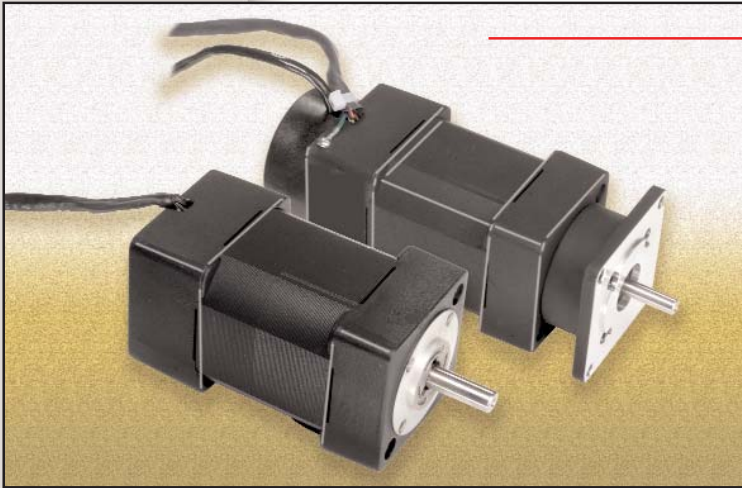

E2200 Series Brushless Motors

Features and Benefits

- *Dynamically balanced armature*
- *High torque-to-weight and inertia ratios*
- *Non-contact sealed ball bearings for improved efficiency and smooth operation*
- *Rare earth neodymium magnets for high acceleration and speed capability*
- *Speeds up to 15000 RPM*

ElectroCraft E2200 Series

The 2200 series offers reliable performance in a small package for your low voltage, lower torque range applications. This series utilizes integrated hall effects to provide consistent speed in either rotation in a small envelope. The 2200 series supports application speeds up to 15,000 RPM while providing long reliable performance.

Typical Applications

- Centrifuges
- Laboratory Equipment
- Copiers
- Printers
- Pumps

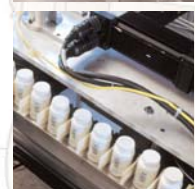

(4) M3X0.5-6HX6.35mm(0.25m) DP MIN.
EQ SP ON 30mm(1.181in) DIA

E2200 Series Performance Specifications

Motor Ratings	2210	2220
Continuous Stall Torque (Ncm)	16.9	33.9
Continuous Stall Torque (oz-in)	24	48
Peak Torque (Ncm)	70.6	141.2
Peak Torque (oz-in)	100	200
Maximum Terminal Voltage (V)	48	48
Maximum Operating Speed (rpm)	15000	15000

Mechanical Data		
Rotor Inertia (kg cm ²)	0.099	0.134
Rotor Inertia (oz-in-sec ²)	0.0014	0.0019
Damping Constant (Ncm/krpm)	0.311	0.466
Damping Constant (oz-in/krpm)	0.44	0.66
Thermal Resistance (C/watt)	2.7	2.3
Maximum Armature Temperature (C)	125	125
Maximum Friction Torque (Ncm)	0.4	0.8
Maximum Friction Torque (oz-in)	0.5	1.1
Maximum Radial Load (25mm from bearing) (Kg)	2.3	2.3
Maximum Radial Load (25mm from bearing) (lbs)	5	5
Weight (Kg)	0.8	0.9
Weight (lbs)	1.75	2

Electrical Data	A	B	A	B
Kt Torque Constant +-10% (Ncm/amp)	4.0	8.4	4.0	8.0
Kt Torque Constant +-10% (oz-in/amp)	5.7	11.9	5.7	11.3
Ke Voltage Constant +-10% (V/Krpm)	4.2	8.8	4.2	8.4
Terminal Resistance (ohms)	1	4.1	0.33	1.3
Maximum Continuous Current (A)	4.2	2.0	8.4	4.2
Maximum Peak Current (A)	19	9	38	19
Armature Inductance (mH)	1.5	6.2	0.5	2.5

Hall Effect Electrical Data	
Hall type	Three channel
Output type	Open collector transistor
Output sink current	10mA at 0.4 Volt maximum
(On state) Output Voltage	4.9 Volt minimum
(On state) Power supply	5VDC at 20mA DC
Operating temperature	0° to 70°C
C.W. Rotation	Motor
Phase R	Blue
Phase S	Brown
Phase T	Violet
Hall Board +5V	Red
Hall Board Ground	Black
Hall Board Hall A	Yellow
Hall Board Hall B	White
Hall Board Hall C	Orange

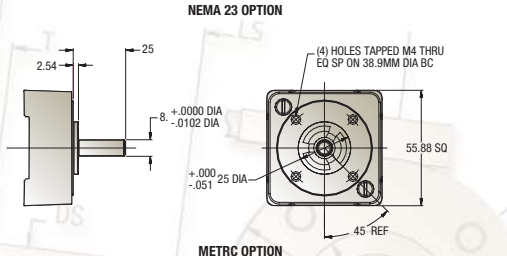
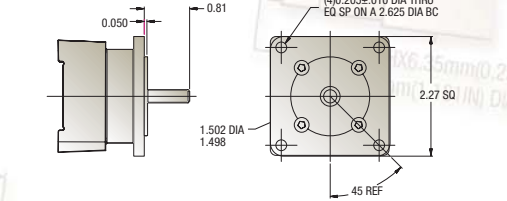
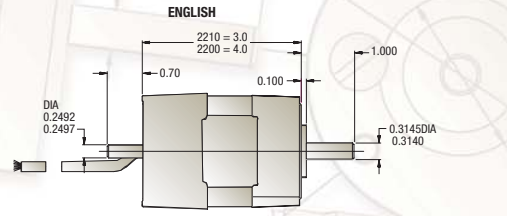
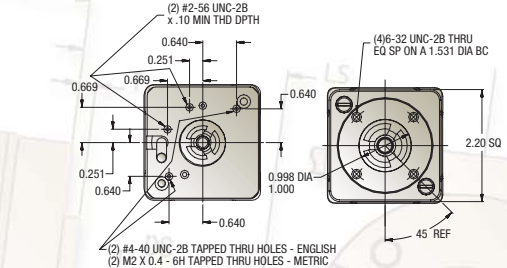

E2210

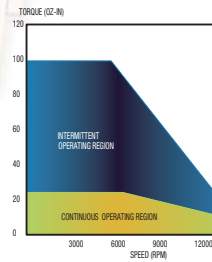

E2220

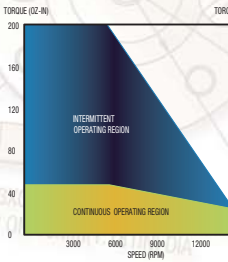

Commutation Sequence Diagram
For CCW Rotation Viewed from Mounting Face

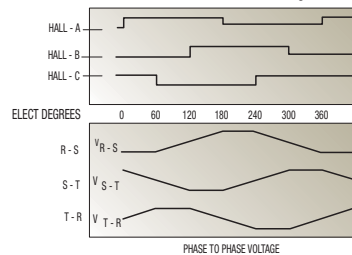

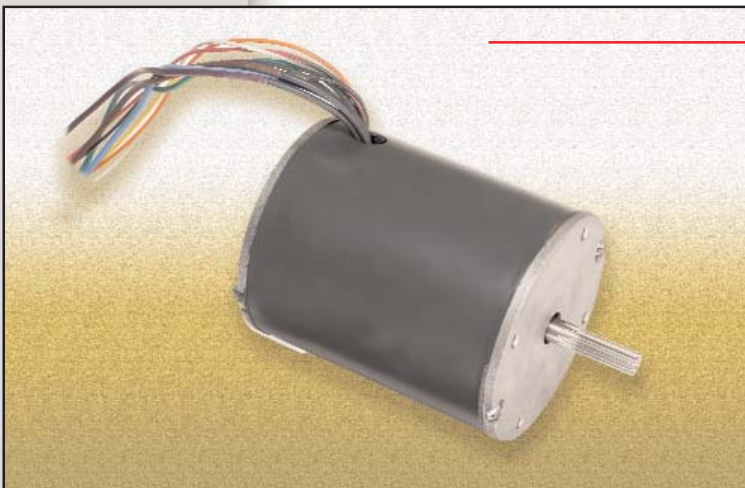

E2600 Series Brushless Motors

Features and Benefits

- *Skewed magnetization for low torque ripple and smooth low speed performance*
- *M-8 ceramic magnets for high acceleration and speed capability*
- *Non-contact sealed ball bearings for improved efficiency and smooth operation*
- *Speeds up to 7500 RPM*

ElectroCraft E2600 Series

The 2600 series offers reliable performance in a small package for your low voltage, lower torque range applications. This series features an economic design available in both closed and open shell configurations.

The 2600 series supports application speeds up to 7,500 RPM while providing long reliable performance.

Typical Applications

- Material Handling
- Packaging
- Marking Equipment
- Copiers
- Printers
- Pumps



(4) M3X0.5-6HX6.35mm(0.25m) DP MIN
EQ SP ON 30mm(1.181in) DIA

E2600 Series Performance Specifications

Motor Ratings	2610	2620
Continuous Stall Torque (Ncm)	19.8	39.5
Continuous Stall Torque (oz-in)	28	56
Peak Torque (Ncm)	102.4	173.0
Peak Torque (oz-in)	145	245
Maximum Terminal Voltage (V)	160	160
Maximum Operating Speed (rpm)	7500	7500

Mechanical Data		
Rotor Inertia (kg cm ²)	0.636	1.200
Rotor Inertia (oz-in-sec ²)	0.0090	0.0170
Damping Constant (Ncm/krpm)	1.483	1.695
Damping Constant (oz-in/krpm)	2.10	2.40
Thermal Resistance (C/watt)	2.5	2.4
Maximum Armature Temperature (C)	155	155
Maximum Friction Torque (Ncm)	1.4	1.8
Maximum Friction Torque (oz-in)	2	2.5
Maximum Radial Load (25mm from bearing) (Kg)	6.8	6.8
Maximum Radial Load (25mm from bearing) (lbs)	15	15
Weight (Kg)	1.4	2.3
Weight (lbs)	3.1	5

Electrical Data	A	B	A	B
Kt Torque Constant +10% (Ncm/amp)	11.4	22.9	11.4	22.9
Kt Torque Constant +10% (oz-in/amp)	16.2	32.4	16.2	32.4
Ke Voltage Constant +10% (V/Krpm)	12.0	24.0	12.0	24.0
Terminal Resistance (ohms)	2.1	8.4	0.71	2.6
Maximum Continuous Current (A)	1.8	0.9	3.5	1.7
Maximum Peak Current (A)	9	4.5	15.1	7.6
Armature Inductance (mH)	4.2	16.8	1.8	7.3

Hall Effect Electrical Data	
Hall type	Three channel
Output type	Open collector transistor
Output sink current	10mA at 0.4 Volt maximum
(On state) Output Voltage	4.9 Volt minimum
(On state) Power supply	5VDC at 20mA DC
Operating temperature	0° to 70°C
C.W. Rotation	Motor
Phase R	Blue
Phase S	Brown
Phase T	Violet
Hall Board +5V	Red
Hall Board Ground	Black
Hall Board Hall A	Yellow
Hall Board Hall B	White
Hall Board Hall C	Orange

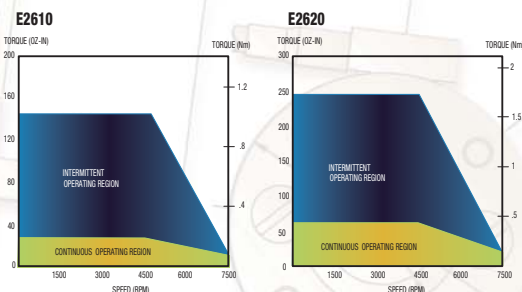
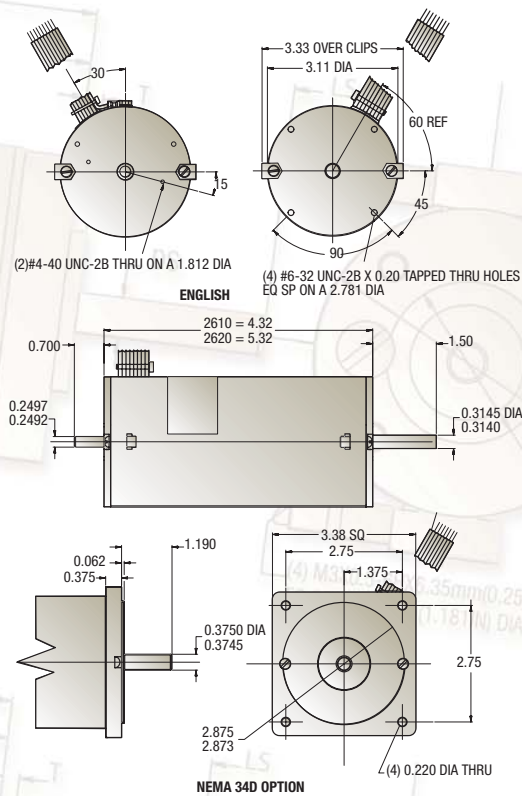

Commutation Sequence Diagram
 For CCW Rotation Viewed from Mounting Face

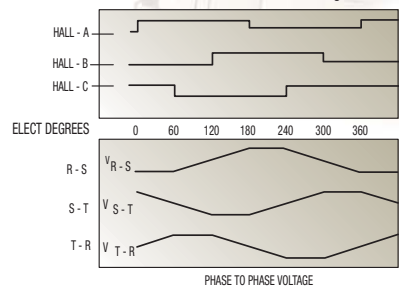

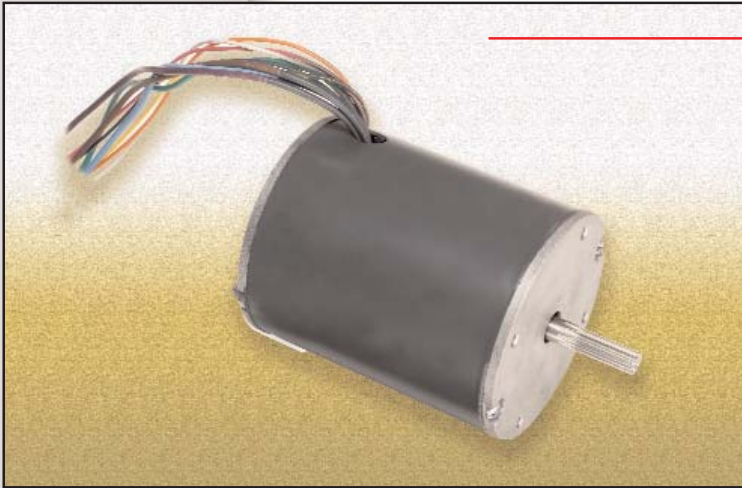

E2900 Series Brushless Motors

Features and Benefits

- *Skewed magnetization for low torque ripple and smooth low speed performance*
- *M-8 ceramic magnet*
- *Non-contact sealed ball bearings for improved efficiency and smooth operation*
- *M-8 ceramic magnets for high acceleration and speed capability*
- *Speeds up to 7500 RPM*

ElectroCraft E2900 Series

The 2900 series offers high output in a highly efficient package for mid to low voltage, mid-level to high torque applications. This series features an economic design available in both closed and open shell configurations.

The 2900 series supports application speeds up to 7,500 RPM while providing long reliable performance.

Typical Applications

- Pumps
- Fans
- Conveyors
- Light Industrial



(4) M3X0.5-6HX6.35mm(0.25m) DP MIN
EQ SP OR 30mm(1.181in) DIA

E2900 Series Performance Specifications

Motor Ratings	2910	2920	2930
Continuous Stall Torque (Ncm)	35.3	60.0	102.4
Continuous Stall Torque (oz-in)	50	85	145
Peak Torque (Ncm)	137.7	229.5	406.1
Peak Torque (oz-in)	195	325	575
Maximum Terminal Voltage (V)	160	160	160
Maximum Operating Speed (rpm)	7500	7500	7500

Mechanical Data			
Rotor Inertia (kg cm ²)	0.636	1.200	1.765
Rotor Inertia (oz-in-sec ²)	0.0090	0.0170	0.0250
Damping Constant (Ncm/krpm)	1.624	1.836	2.048
Damping Constant (oz-in/krpm)	2.30	2.60	2.90
Thermal Resistance (C/watt)	2.6	2.2	1.9
Maximum Armature Temperature (C)	155	155	155
Maximum Friction Torque (Ncm)	1.4	2.1	2.8
Maximum Friction Torque (oz-in)	2	3	4
Maximum Radial Load (25mm from bearing) (Kg)	6.8	6.8	6.8
Maximum Radial Load (25mm from bearing) (lbs)	15	15	15
Weight (Kg)	1.5	2.6	3.6
Weight (lbs)	3.3	5.8	7.9

Electrical Data	A	B	A	B	A	B
Kt Torque Constant +-10% (Ncm/amp)	11.4	22.9	11.4	22.9	11.4	22.9
Kt Torque Constant +-10% (oz-in/amp)	16.2	32.4	16.2	32.4	16.2	32.4
Ke Voltage Constant +-10% (V/Krpm)	12.0	24.0	12.0	24.0	12.0	24.0
Terminal Resistance (ohms)	1.36	5.28	0.49	1.86	0.30	1.03
Maximum Continuous Current (A)	3.1	1.5	5.2	2.6	9.0	4.5
Maximum Peak Current (A)	12	6	20	10	35	17.7
Armature Inductance (mH)	3.9	16.4	1.8	7.3	1.2	4.5

Hall Effect Electrical Data	
Hall type	Three channel
Output type	Open collector transistor
Output sink current	10mA at 0.4 Volt maximum
(On state) Output Voltage	4.9 Volt minimum
(On state) Power supply	5VDC at 20mA DC
Operating temperature	0° to 70°C
C.W. Rotation	Motor
Phase R	Blue
Phase S	Brown
Phase T	Violet
Hall Board +5V	Red
Hall Board Ground	Black
Hall Board Hall A	Yellow
Hall Board Hall B	White
Hall Board Hall C	Orange

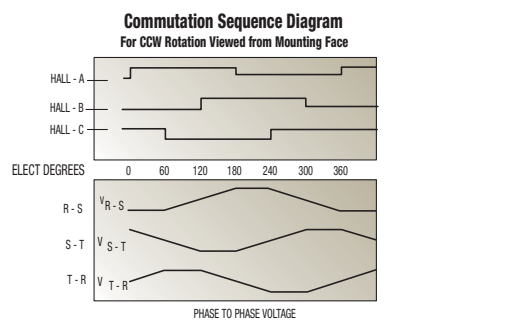
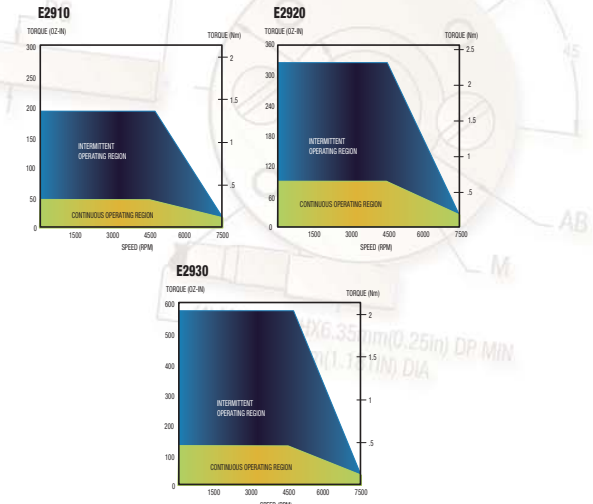
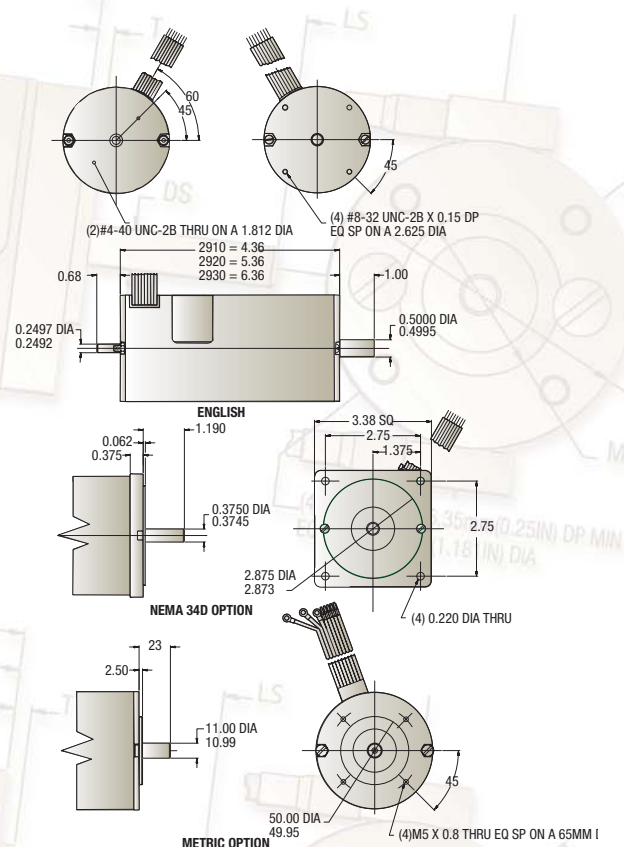



E3300 Series Brushless Motors

Features and Benefits

- *Skewed magnetization for low torque ripple and smooth low speed performance*
- *M-8 ceramic magnets for high acceleration and speed capability*
- *Non-contact sealed ball bearings for improved efficiency and smooth operation*
- *Speeds up to 7500 RPM*

ElectroCraft E3300 Series

The 3300 series offers high output in a highly efficient package for mid to low voltage, mid-level to high torque applications. This series features an economic design available in both closed and open shell configurations. The 3300 series supports application speeds up to 7,500 RPM while providing long reliable performance.

Typical Applications

- Material Handling
- Pumps
- Fans
- Medical
- Light Industrial



(4) M3X0.5-6HX6.35mm(0.25m) DP MIN
 EQ SP ON 30mm(1.181in) DIA

E3300 Series Performance Specifications

Motor Ratings	3310	3320	3330
Continuous Stall Torque (Ncm)	37.4	74.2	113.0
Continuous Stall Torque (oz-in)	53	105	160
Peak Torque (Ncm)	173.0	335.5	512.0
Peak Torque (oz-in)	245	475	725
Maximum Terminal Voltage (V)	160	160	160
Maximum Operating Speed (rpm)	7500	7500	7500

Mechanical Data			
Rotor Inertia (kg cm ²)	1.200	2.189	3.178
Rotor Inertia (oz-in-sec ²)	0.017	0.031	0.045
Damping Constant (Ncm/krpm)	1.907	2.118	2.330
Damping Constant (oz-in/krpm)	2.70	3.00	3.30
Thermal Resistance (C/watt)	2.1	1.7	1.5
Maximum Armature Temperature (C)	155	155	155
Maximum Friction Torque (Ncm)	2.1	2.5	2.8
Maximum Friction Torque (oz-in)	3	3.5	4
Maximum Radial Load (25mm from bearing) (Kg)	9.1	9.1	9.1
Maximum Radial Load (25mm from bearing) (lbs)	20	20	20
Weight (Kg)	2.2	3.4	4.5
Weight (lbs)	4.9	7.4	9.9

Electrical Data	A	B	A	B	A	B
Kt Torque Constant +-10% (Ncm/amp)	11.4	22.9	11.4	22.9	10.7	20.8
Kt Torque Constant +-10% (oz-in/amp)	16.2	32.4	16.2	32.4	15.1	29.4
Ke Voltage Constant +-10% (V/Krpm)	12.0	24.0	12.0	24.0	11.2	21.7
Terminal Resistance (ohms)	0.94	3.63	0.33	1.18	0.18	0.63
Maximum Continuous Current (A)	3.3	1.6	6.5	3.2	10.6	5.4
Maximum Peak Current (A)	15.1	7.6	29.3	14.7	49.0	24.0
Armature Inductance (mH)	3.2	13.3	1.4	5.5	0.6	2.8

Hall Effect Electrical Data	
Hall type	Three channel
Output type	Open collector transistor
Output sink current	10mA at 0.4 Volt maximum
(On state) Output Voltage	4.9 Volt minimum
(On state) Power supply	5VDC at 20mA DC
Operating temperature	0° to 70°C
C.W. Rotation	Motor
Phase R	Blue
Phase S	Brown
Phase T	Violet
Hall Board +5V	Red
Hall Board Ground	Black
Hall Board Hall A	Yellow
Hall Board Hall B	White
Hall Board Hall C	Orange

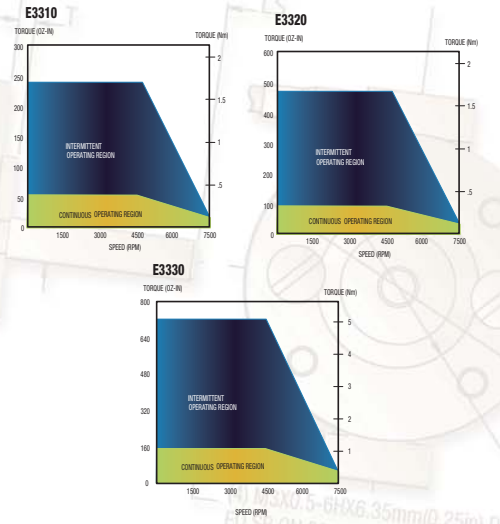
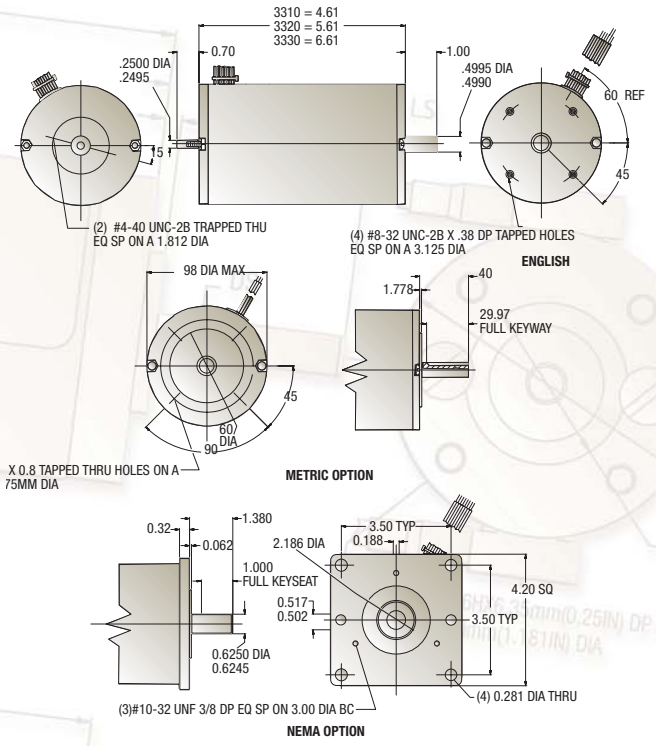

Commutation Sequence Diagram
For CCW Rotation Viewed from Mounting Face

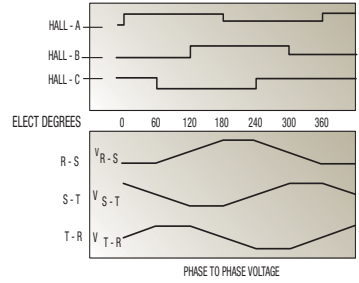

ElectroCraft E Series Model Designations

E22 05A - ETH2

Series
E-Brushless Servo Motors

Frame Designator
22- 2.2 Frame (2.20" square)
26- 26 Frame (3.11" Diameter)
29- 29 Frame (3.42" Diameter)
33- 330 Frame (3.86 Diameter)

Length Designator
05-30 based on available
motor lengths (see catalog)

Winding Designator
A- see catalog for specific values
B- see catalog for specific values
Z- Custom

Mounting Designator
E-English
M-Metric
N-NEMA
Z-custom-consult factory

Lead Designator
F- Flying leads -
see catalog if applicable
J- Junction Box - 33 Frame only
Z- Custom

Feedback Designator
1,2,Z- 1=1000ppr, 2=2000ppr,
Z=custom line count
H- Hall effect only

Brake Designator
(omit if not applicable)
1,2,3,Z- 1=12VDC, 2=24VDC
3=90VDC, Z=Custom

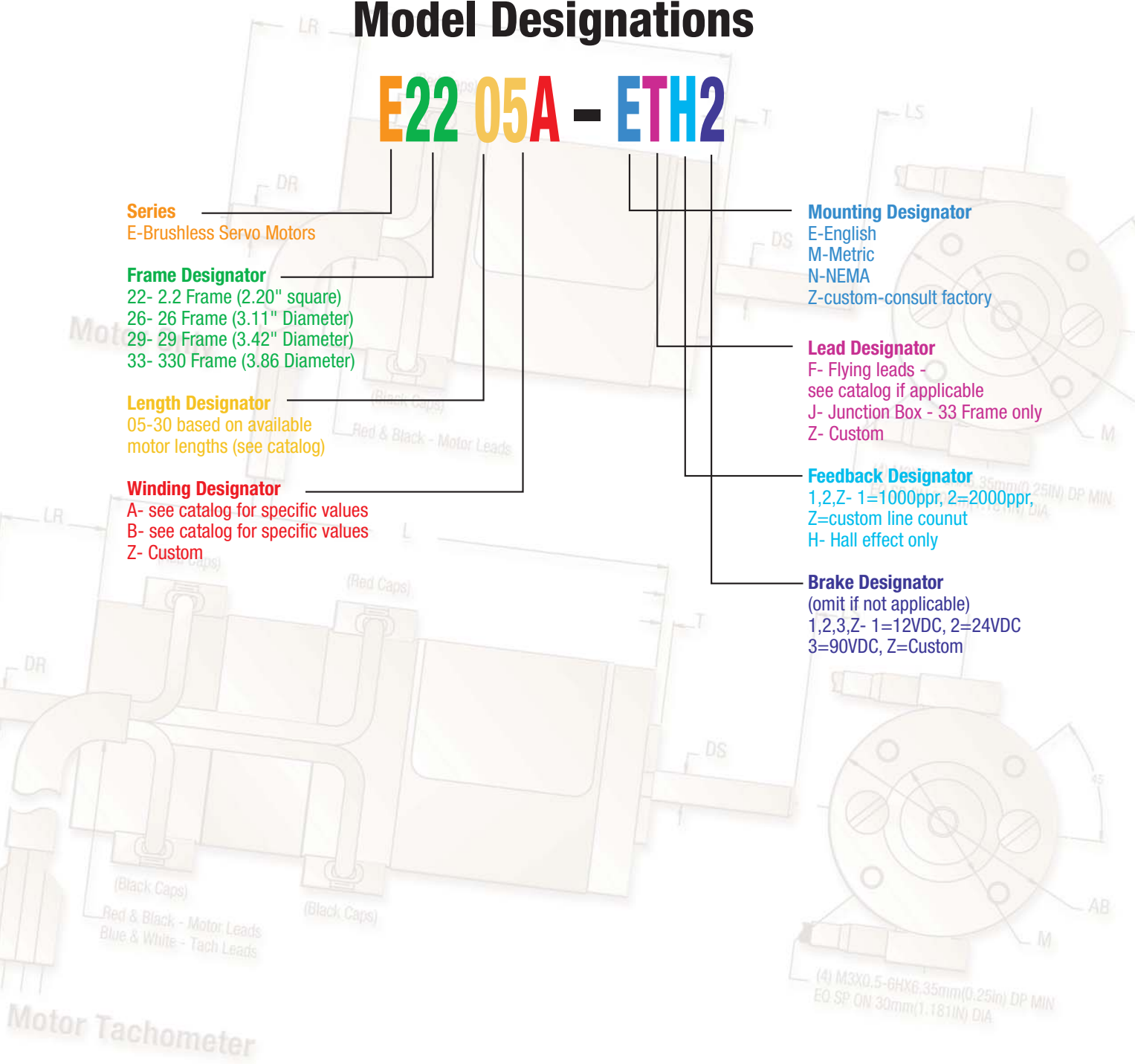

Motor Tachometer

E Series Model Designations

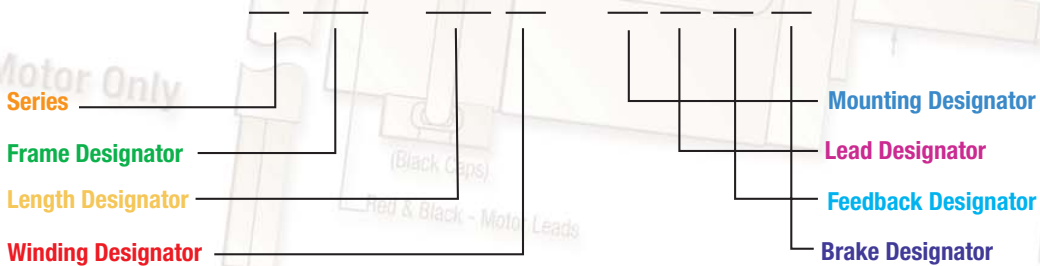

Please explain any custom (Z) designators:

Please indicate any special features not covered in the model number:

ElectroCraft specializes in assisting you with an engineered solutions to meet your application needs. We also specialize in sourcing and assembling value added components to your assembly. Please contact your area sales representative (see world wide locations section) for assistance with your application needs.

Need a product fast?! ElectroCraft carries a limited supply of off-the-shelf model variations available for shipment within 48 hours. Please contact your area sales representative or our inside sales staff for a complete listing of stocked model numbers and pricing sheet.

Motor Tachometer



NOTES

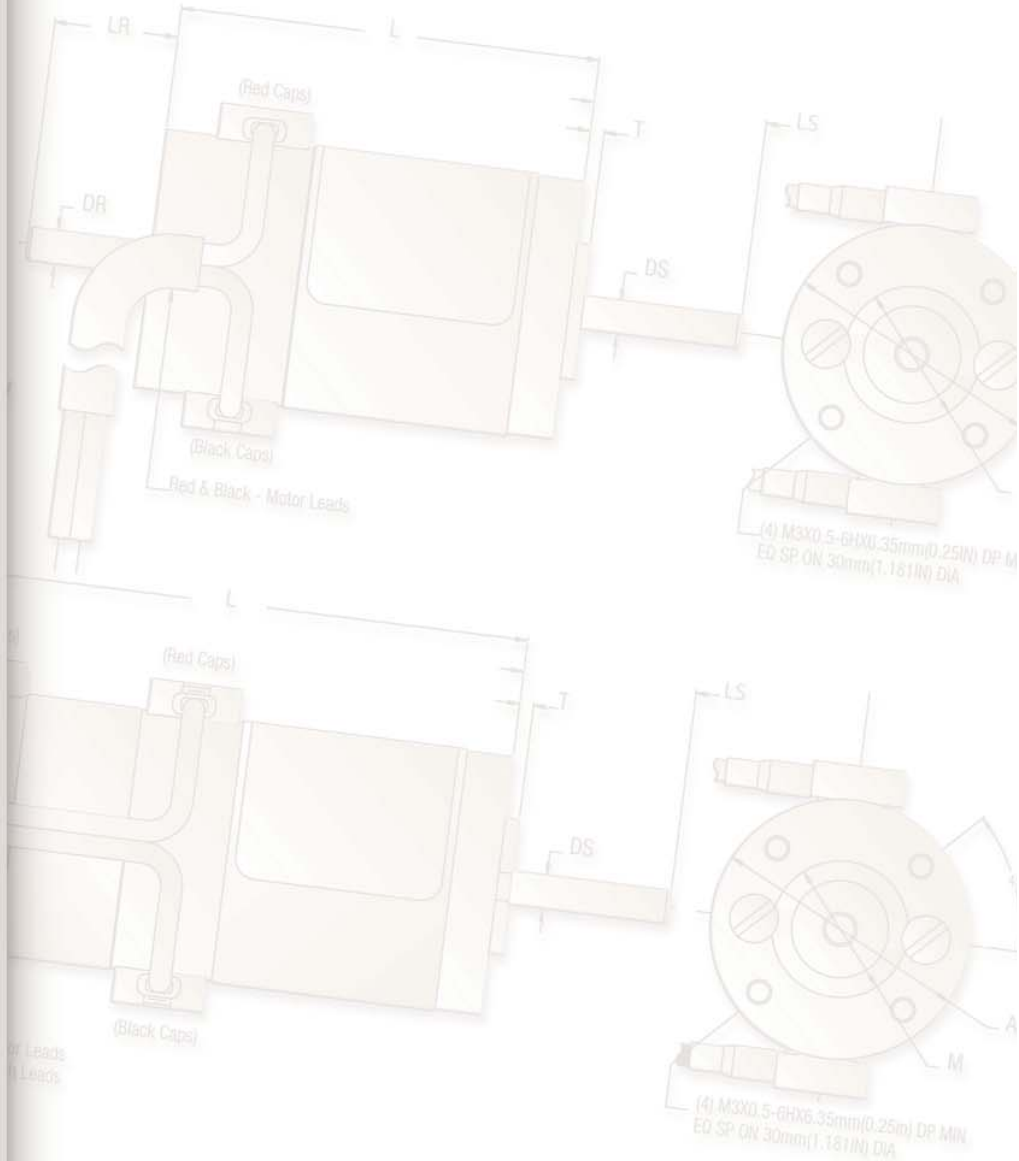

Motor Only

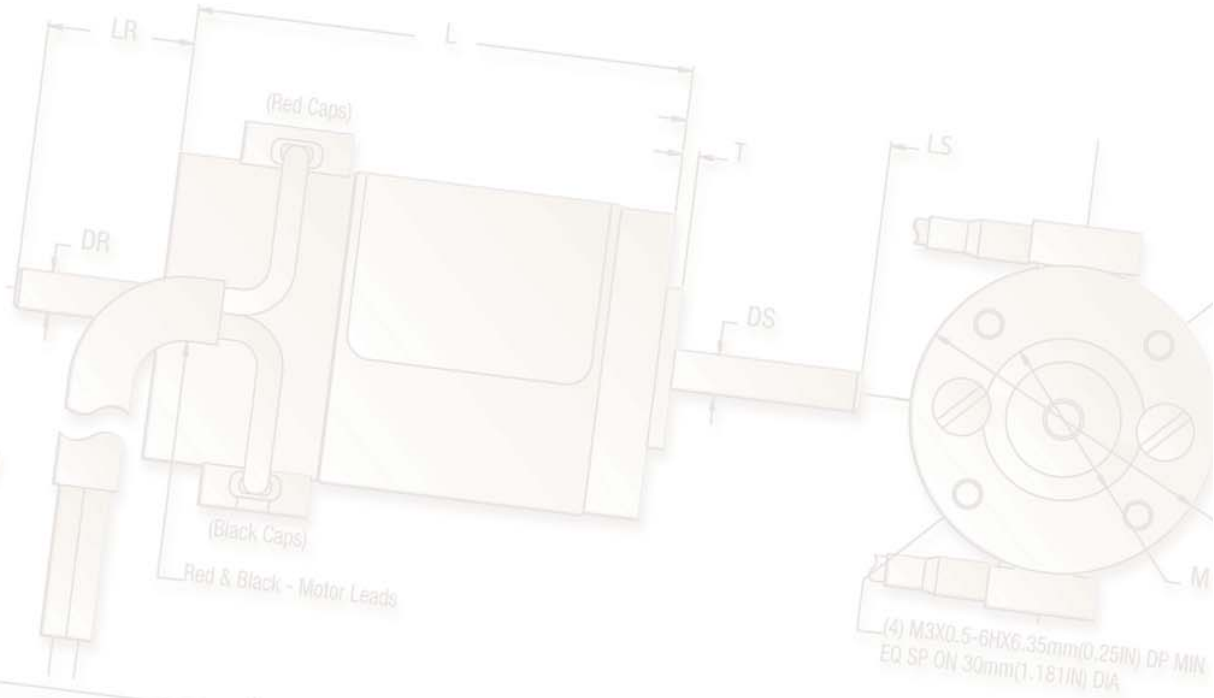

Motor Tachometer

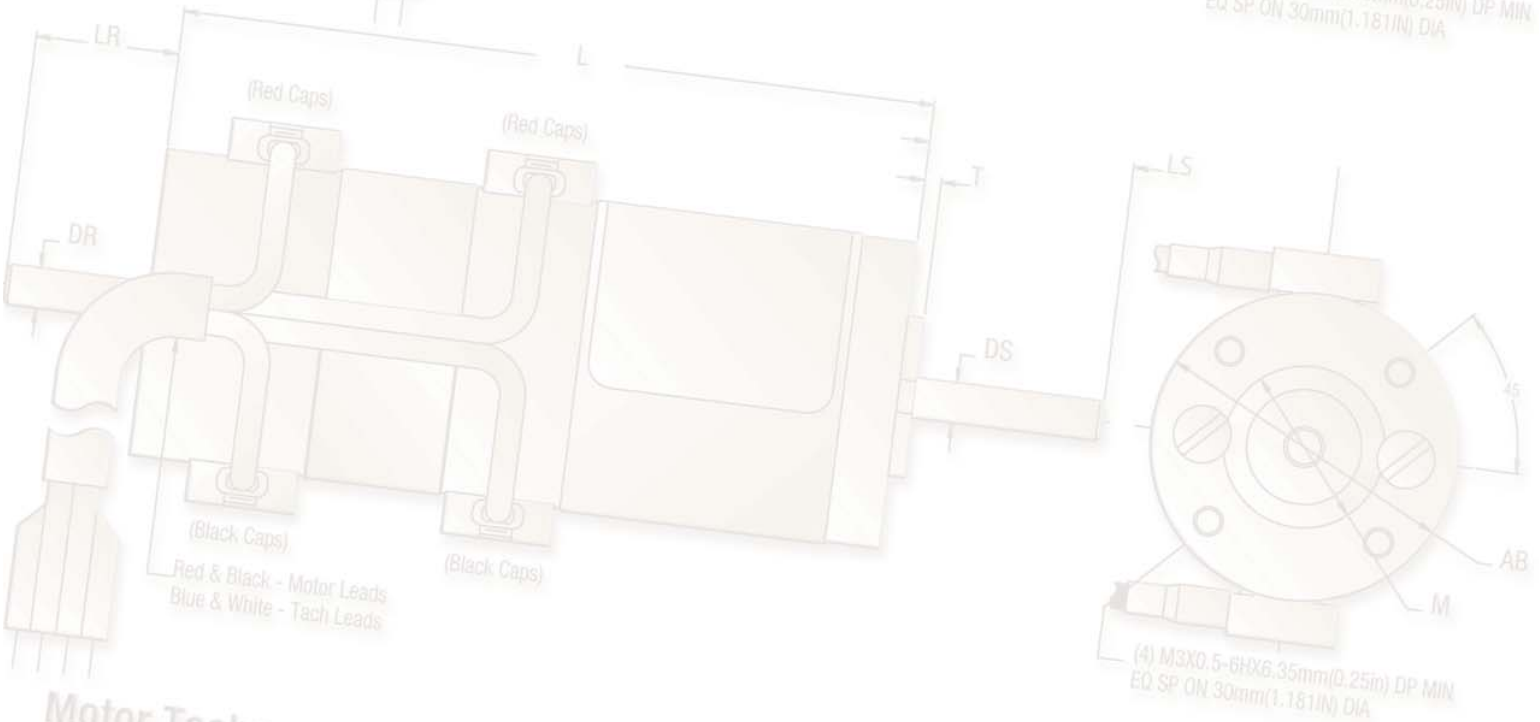

ElectroCraft Engineered Solutions is dedicated to supplying customized solutions for OEM power transmission requirements. By combining the innovative thinking of skilled personnel with quality manufacturing processes and specialized equipment, we are able to offer premium AC, DC servo, and brushless DC motors, which have become world recognized for their quiet operation, high efficiency and robust designs. We offer complete packages to OEMs to allow the ease of purchasing all their power transmission solutions from a single source. ElectroCraft Engineered Solutions is dedicated to supplying the OEM with optimized automation solutions. Quiet operation, high efficiency, and robust designs have earned us a reputation for leadership in the industry. We offer a complete package of motor, gearhead, transaxle, and brake in a variety of design options and gear ratios. For additional information on this product or any other ElectroCraft products, please contact your nearest ElectroCraft sales office.

