

SERIES MC/MF MOUNTING CARDS

Models: MC1X510, MC2X510, MC3X510, MF1X510, MF2X510 and MF3X510

FEATURES:

- Differential or single-ended inputs
- Potentiometer adjustments for offset/test, input gain, tach, IR compensation, and current limit
- Current, voltage, tachometer, and IR compensation modes
- Agency Approvals:



DESCRIPTION: *ADVANCED MOTION CONTROLS* MC series mounting card product line is designed to host up to three model 10A8's. Customer is provided $\pm 10\text{ V} @ \pm 3\text{ mA}$ for use at the screw terminals. Part numbers beginning with "MC" host 10A8's. Part numbers beginning with "MF" host 10A8's and feature an onboard filter in the motor lines. The schematic below describes combinations of 10A8's for 1-, 2-, and 3-axis cards.

POTENTIOMETER FUNCTIONS (axis 1, 2 and 3 respectively):

POTENTIOMETER	DESCRIPTION	TURNING CW
Pot 5, 10, 15	Tachometer gain adjustment (normally not necessary and not factory installed)	Increase
Pot 4, 9, 14	Adjustment of IR compensation feed back amount	Increase
Pot 3, 8, 13	Current limit adjustment	Increase
Pot 2, 7, 12	Input gain adjustment	Increase
Pot 1, 6, 11	Adjustment of any offset or imbalance in the amplifier/card assembly or in the input signal.	N/A

SERVO AMPLIFIER/CARD CONFIGURATIONS: The operating modes are selected by DIP switches according to the table on the block diagram shown below. When SW 1, 5, 9 are in "test mode", the sensitivity of the offset pots is increased so they can be used as an "on-board reference signal".

CURRENT MODE REFERENCE-GAIN ADJUSTMENTS: Connect "+ C" to "+ 10 V" on screw terminal and adjust Pot 2, 7, 12 (for channels #1, 2, 3) to obtain -5 V at the test point located between Pot 2, 7, 12 and edge of card. Adjust the potentiometer located on the side of the amplifier module to obtain -7.25 V at left contacts of C3, 43, and 63 (which are connected to pin 10 of module). C3, 43, 63 are not factory installed.

AMPLIFIER LOOP-COMPENSATION: In Voltage and Tachometer Mode rotate the potentiometer located on the side of the amplifier module clockwise until oscillation occurs, and then turn counter-clockwise until oscillation stops. The Input Gain Adjustment (pot 2, 7, 12) is used as a scaling factor between the command signal and the control variable. In this case it is the velocity of the motor. In current mode, this pot should be turned fully counter-clockwise.

IR COMPENSATION CONFIGURATION: Rotate the potentiometer located on the side of the amplifier module clockwise until oscillation occurs, and then turn counter-clockwise until oscillation stops. Repeat this procedure for Pot 4, starting from a fully CW position, turn CCW until oscillation. See section "G" for more information on IR Compensation.

ANALOG POSITION LOOP MODE:

In this mode the feedback device is an analog potentiometer mechanically tied to the positioned object. This potentiometer can be powered by the card ($\pm 10V$). The command is an analog signal, which can be supplied by the user, or a potentiometer supplied by the card ($\pm 10V$). See analog position mode block diagram in section "G". Tune amplifier in voltage mode (or in IR compensation mode for best results), then connect the analog position feedback and turn Pot 2 clockwise until oscillation occurs. Finally, rotate Pot 2 counter-clockwise to stop oscillation. (Oscillation may not occur).

MECHANICAL SPECIFICATIONS:

CONNECTORS	All versions	Screw Terminals	
SIZE	MC1X510	3.80 x 4.98 x 1.10 inches	96.5 x 126.5 x 26.5 mm
	MC2X510	6.02 x 4.98 x 1.10 inches	152.9 x 126.5 x 26.5 mm
	MC3X510	8.00 x 4.98 x 1.10 inches	203.3 x 126.5 x 26.5 mm
WEIGHT	MC1X510	4 oz.	0.113 kg.
	MC2X510	5 oz.	0.142 kg.
	MC3X510	7 oz.	0.198 kg.

PIN FUNCTIONS:

CONNECTOR	PIN	NAME	DESCRIPTION/NOTES	I/O
P2	1	+HV	DC power supply (20-80VDC)	I
	2	GND	Power supply ground	GND
	3	gnd	Signal ground (same as P2-2)	GND
	4	+10V @ 3 mA	For Customer Use	O
	5	-10V @ 3 mA	For Customer Use	O

CONNECTOR	PIN	NAME	DESCRIPTION/NOTES	I/O
P3,P4,P5	1	-M1, -M2, -M3	- Motor	O
	2	+M1, +M2, +M3	+ Motor	O
	3	-T1, -T2, -T3	- Tachometer (or analog position feedback)	I
	4	+T1, +T2, +T3	+ Tachometer (or analog position feedback)	I
	5	+C1, +C2, +C3	+ Command signal	I
	6	-C1, -C2, -C3	- Command signal	I
	7	INH1,2, 3	Apply +3V to +15V @ 3 mA to inhibit	I
	8	gnd	Ground reference	GND

MOUNTING DIMENSIONS: See page F-6.

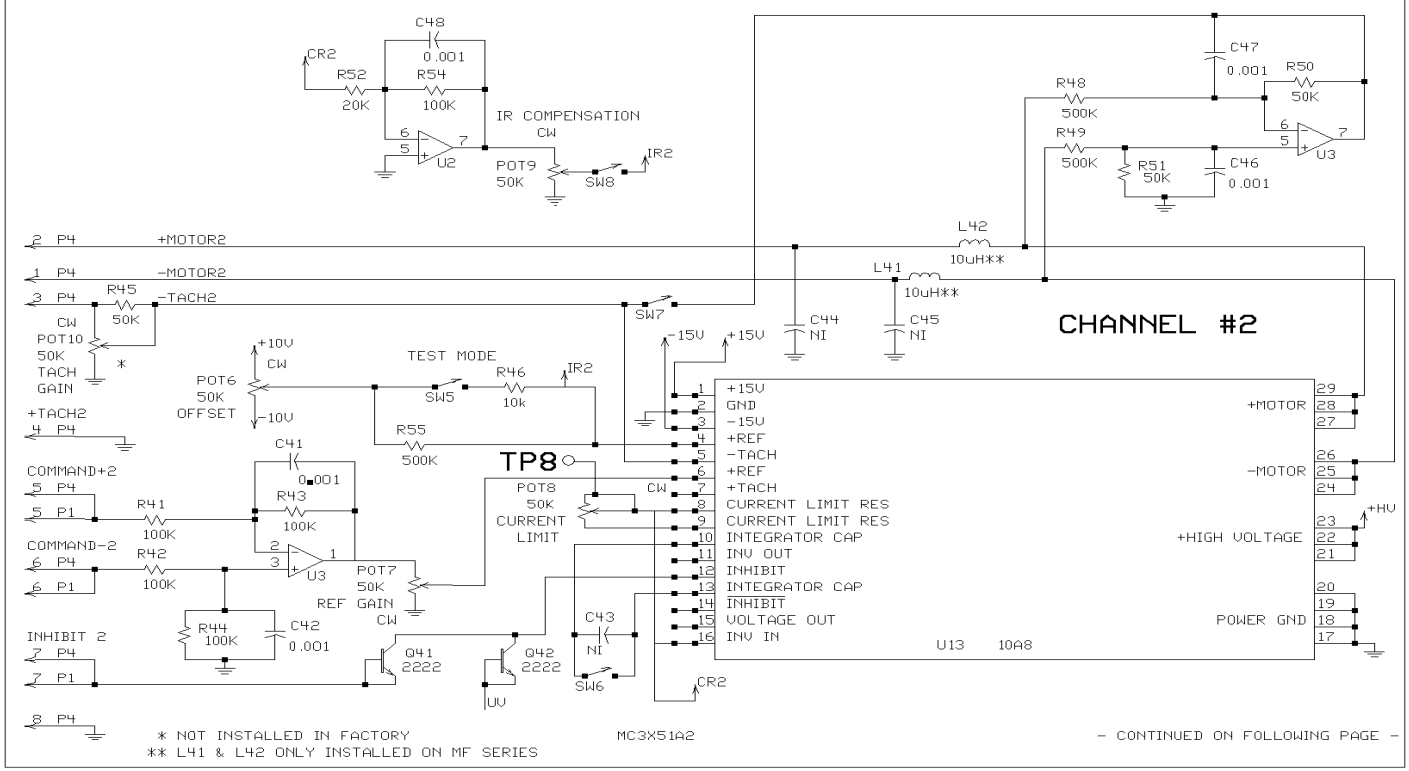
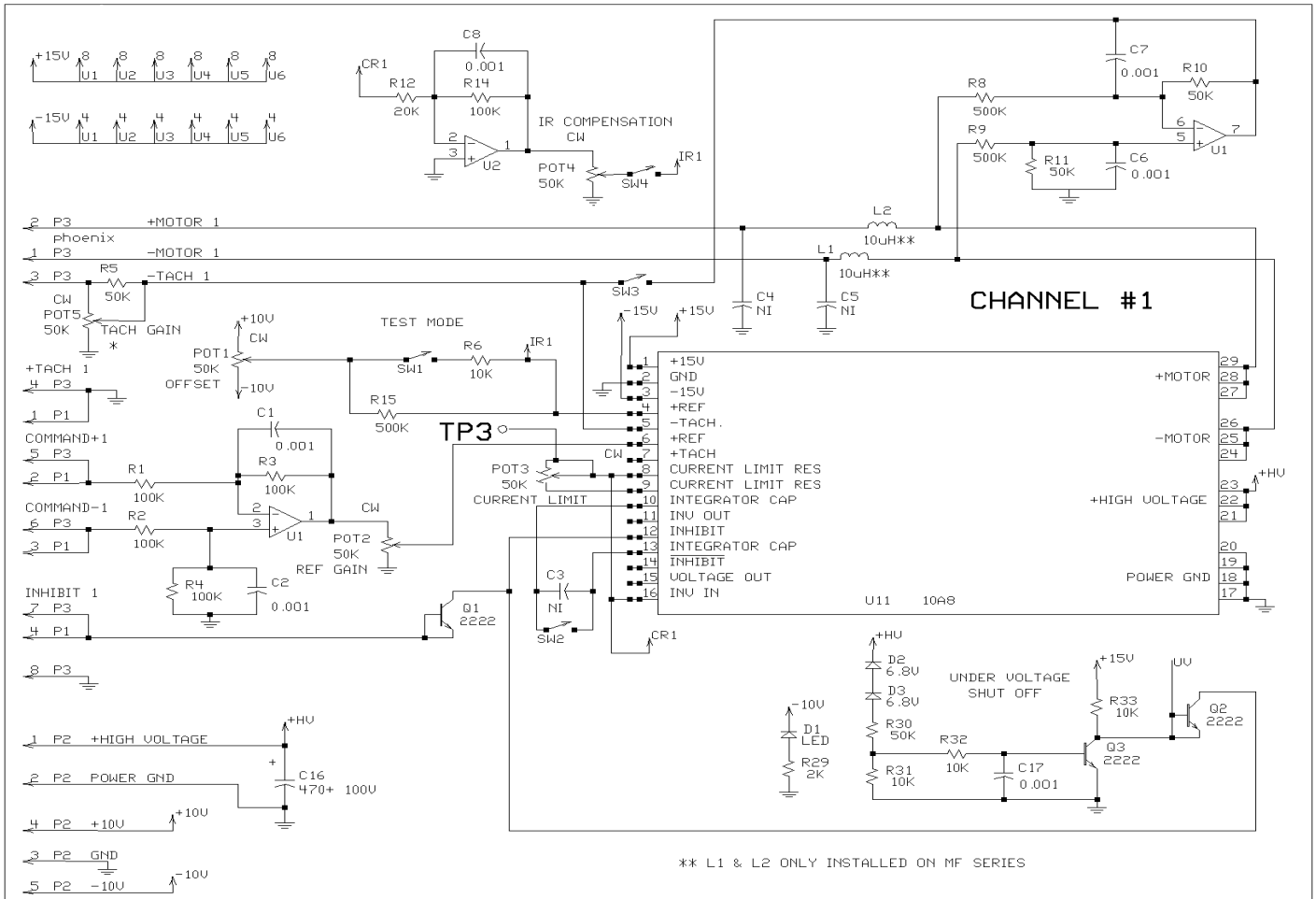

CONTINUED FROM PREVIOUS PAGE -

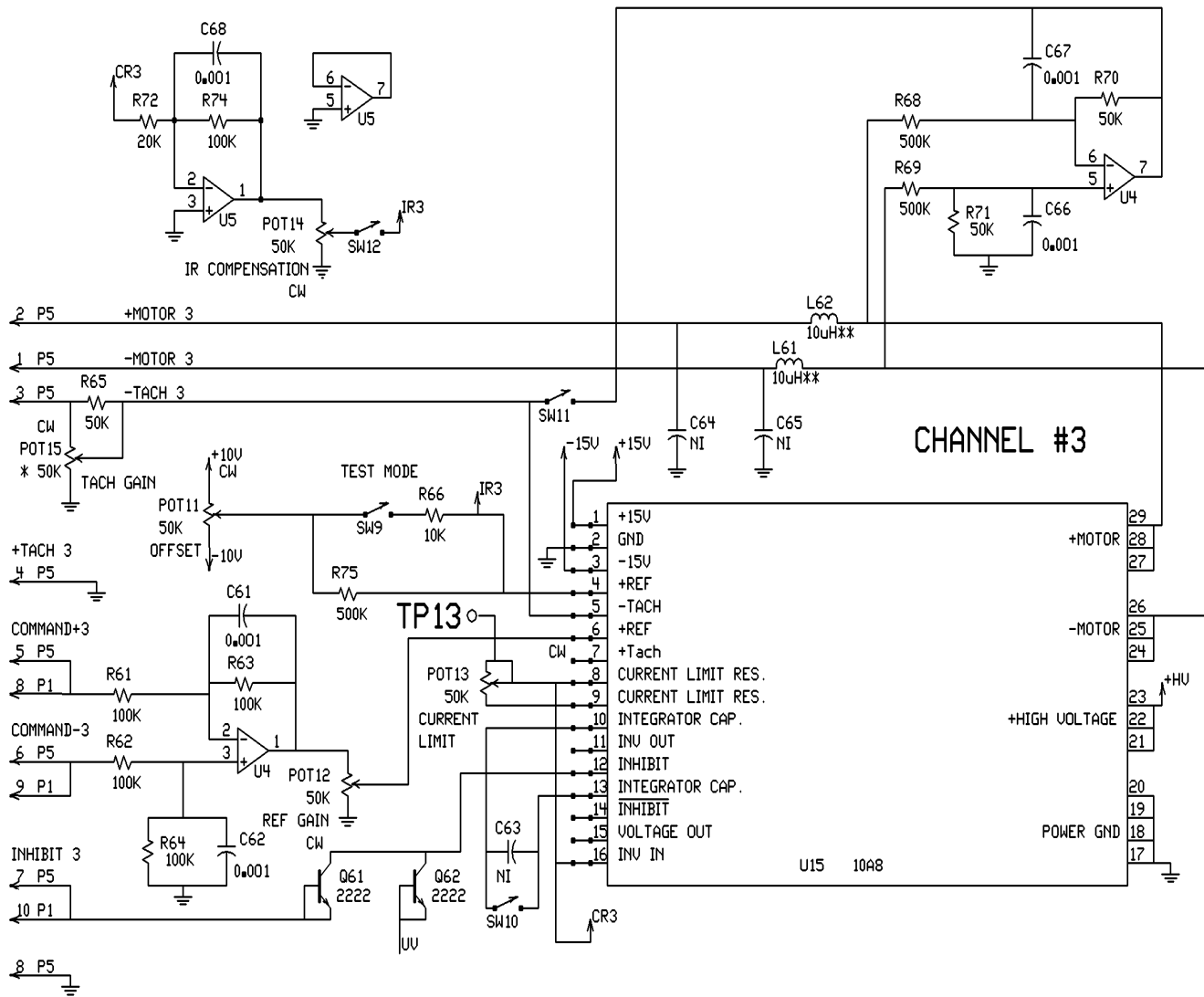

MODE SELECTION TABLE

OPERATING MODES	AMP #1				AMP #2				AMP #3			
	SW1	SW2	SW3	SW4	SW5	SW6	SW7	SW8	SW9	SW10	SW11	SW12
CURRENT MODE	OFF	ON	OFF	OFF	OFF	ON	OFF	OFF	OFF	ON	OFF	OFF
VOLTAGE MODE	OFF	OFF	ON	OFF	OFF	OFF	ON	OFF	OFF	OFF	ON	OFF
IR COMPENSATION	OFF	OFF	ON	ON	OFF	OFF	ON	ON	OFF	OFF	ON	ON
TACHOMETER MODE	OFF	OFF	OFF	OFF	OFF	OFF	OFF	OFF	OFF	OFF	OFF	OFF
TEST MODE	ON	OFF	ON	OFF	ON	OFF	ON	OFF	ON	OFF	ON	OFF
POSITION MODE	OFF	OFF	ON	OFF	OFF	OFF	ON	OFF	OFF	OFF	ON	OFF

* NOT INSTALLED IN FACTORY
 ** L61 & L62 ONLY INSTALLED ON MF SERIES

MC3X51B2

NOTE: DIMENSIONS IN [] ARE IN MM.

MODEL 10A8, 10A8DD

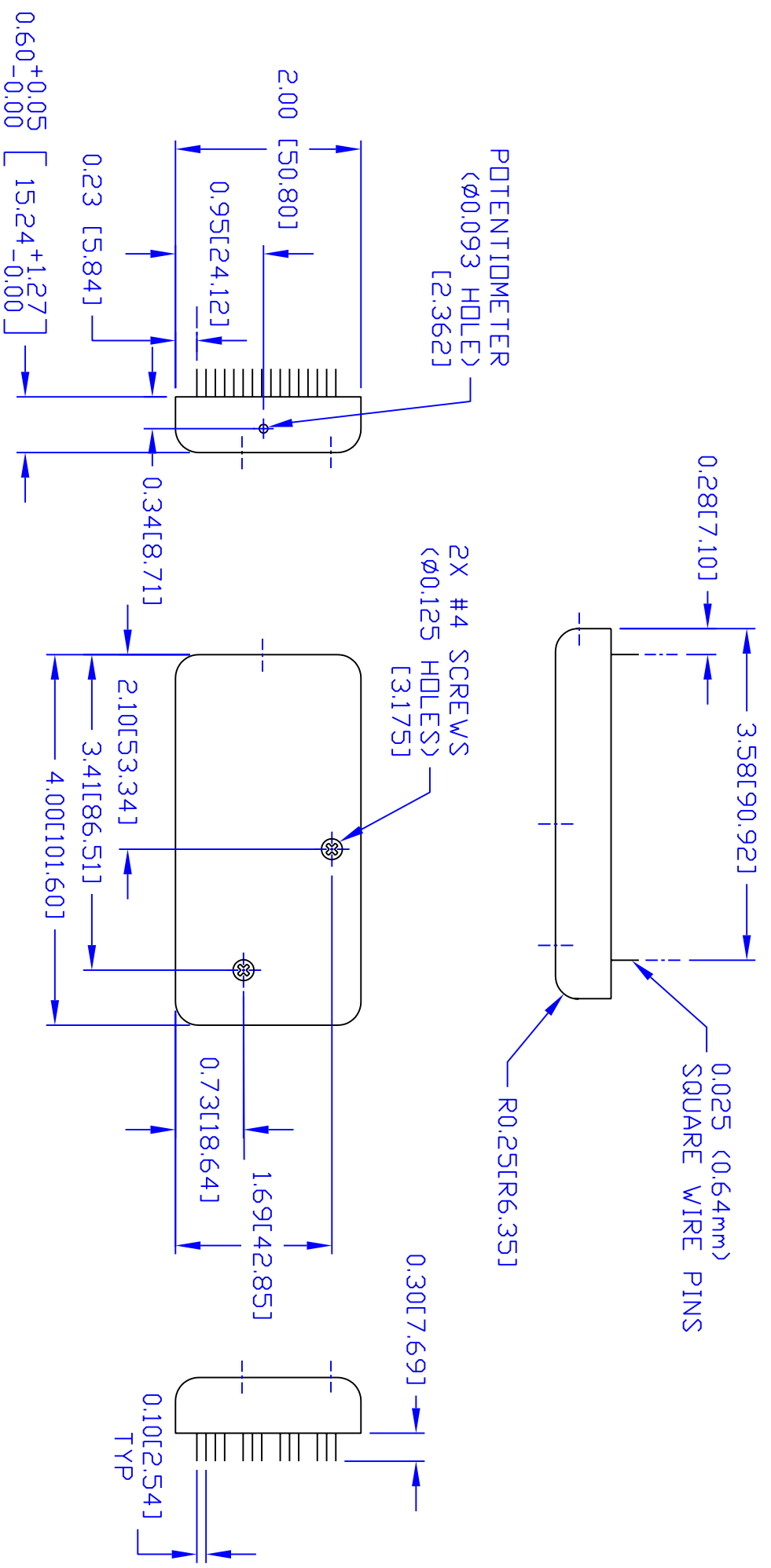

REV	DESCRIPTION	DATE	BY
C	ADDED TOL. TO DIM. 0.60	11/19/03	RB
B	UPDATE ADDRESS ON DWG FORMAT	02/12/02	RB
A	UPDATE DWG FORMAT	08/22/96	RB

UNLESS OTHERWISE SPECIFIED: DIMENSIONS ARE IN INCHES TOLERANCES .XX ± .010 .XXX ± .005 DD NOT SCALE DRAWING		TITLE ADVANCED MOTION CONTROLS • PWM SERVO AMPLIFIERS • 3805 Calle Tecate, Comarillo, CA 93012	
DRAWN BY: AIDA	DATE: 06/03/93	SIZE DWG. NO. B	REV C
CHECK BY:	DATE:	SCALE: NONE	SHT. 1 OF 1
DESIGN APPROVED:	DATE:	MOUNTING DIMENSIONS 10A SERIES	
10A8DD SERIES	10A SERIES	USED ON	