

Note: See page 14 for a complete description of the above part number system.

Sold & Serviced By:

 Toll Free Phone (877) SERV098
 Toll Free Fax (877) SERV099
www.electromate.com
sales@electromate.com

(E) - English Interface	(M) - Metric Interface
(LFT) - Left Facing Thread	(NPL) - Non Preloaded
(LH) - Left Hand	(PL) - Preloaded
(LT) - Low Thrust	(RFT) - Right Facing Thread
(HT) - High Thrust	(RH) - Right Hand

Screw & Nut Specifications

Model Number	Nut Type	Diameter inches (mm)	Lead inches (mm)	Root Diameter inches (mm)	Ball Diameter inches (mm)	Number of Circuits	Static Load lbs (kgf)	Dynamic Load ⁽¹⁾ lbs (kgf)
RS150025 1.500 inch dia. 0.250 inch lead	<i>Non-preloaded Ball (N1/N2)</i>	1.500 (38,10)	0.250 (6,35)	1.379 (35,03)	0.156 (3,96)	2	47,450 (21523)	4,050 (1837)
	<i>Preloaded Ball (N3/N4)</i>						47,045 (21339)	3,645 (1653)
RS150050 1.500 inch dia. 0.500 inch lead	<i>Non-preloaded Ball (N1/N2)</i>	1.500 (38,10)	0.500 (12,70)	1.265 (32,13)	0.312 (7,92)	2	102,300 (46402)	12,900 (5851)
	<i>Preloaded Ball (N3/N4)</i>						101,010 (45817)	11,610 (5266)
RS150100 1.500 inch dia. 1.000 inch lead	<i>Non-preloaded Ball (N1/N2)</i>	1.500 (38,10)	1.000 (25,40)	1.143 (29,03)	0.344 (8,73)	2	47,800 (21682)	8,250 (3742)
	<i>Preloaded Ball (N3/N4)</i>						46,975 (21307)	7,425 (3368)
RS150200 1.500 inch dia. 2.000 inch lead	<i>Non-preloaded Ball (N1/N2)</i>	1.500 (38,10)	2.000 (50,80)	1.210 (30,73)	0.281 (7,13)	2	31,250 (14175)	7,600 (3447)
	<i>Preloaded Ball (N3/N4)</i>						28,240 (12809)	6,840 (3103)

Other Specifications

Maximum Acceleration Rate	Ball nut: 772 inches/sec ² (19.6 m/sec ²)
Maximum Speed	Ball nut: 3000 rpm
Screw Material	Right Hand Thread, Case Hardened Rc 58 Steel Rolled Ball Screw
Screw Extensions	605 Woodruff Keyways on Extensions from Support Housings
Screw Maximum Length ⁽²⁾	144 inches (3657 mm)
Screw Weight	5.58 lbs/ft (83,1 g/cm)
Support Housings	Steel with Black Oxide Finish, 45° Chamfer x .03 inch (0,76) all Straight Edges
Support Housing Features	Base or Face Mount with Integral Seals
Nut Flanges	Steel with Black Oxide Finish
Nut Flange Features	English or Metric Load Mounting Interface

Footnotes:

- (1) Load based upon 1 million inches (25 Km) of travel life. See page 59 for further travel life ratings.
 (2) Maximum stock length (not the maximum thread length with bearing housings). See page 58 for maximum thread lengths for each configuration.

Sold & Serviced By:

 **ELECTROMATE**

Toll Free Phone (877) SERV098

Toll Free Fax (877) SERV099

www.electromate.com

sales@electromate.com

Screw Specifications

Model Number	Nut Type	Screw Efficiency %	Lead Error inch/ft (mm/300 mm)	Backlash inches (mm)	Unidirectional Repeatability inches (mm)	Bidirectional Repeatability inches (mm)
RS150025 1.500 inch dia. 0.250 inch lead & RS150050 1.500 inch dia. 0.500 inch lead & RS150100 1.500 inch dia. 1.000 inch lead & RS150200 1.500 inch dia. 2.000 inch lead	<i>Non-preloaded</i> Ball (N1/N2)	90	< 0.009 (0,229)	< 0.013 (0,330)	+/- 0.0002 (0,0050)	+ 0.0002 to - 0.0132 (0,0050) (0,3353)
	<i>Preloaded</i> Ball (N3/N4)	90	< 0.009 (0,229)	0	+/- 0.0002 (0,0050)	+ 0.0002 to - 0.0002 (0,0050) (0,0050)

Assembly Specifications

Model Number	Nut Type	Breakaway Torque oz-in (N-m)				
		Simple-Simple	Fixed(LT)-Simple	Fixed(HT)-Simple	Rigid-Simple	Rigid-Rigid
RS150025 1.500 inch dia. 0.250 inch lead	<i>Non-preloaded</i> Ball (N1/N2)	< 35 (0,25)	< 50 (0,35)	< 70 (0,49)	< 70 (0,49)	< 90 (0,64)
	<i>Preloaded</i> Ball (N3/N4)	< 70 (0,49)	< 85 (0,60)	< 105 (0,74)	< 105 (0,74)	< 125 (0,88)
RS150050 1.500 inch dia. 0.500 inch lead	<i>Non-preloaded</i> Ball (N1/N2)	< 40 (0,28)	< 55 (0,39)	< 75 (0,53)	< 75 (0,53)	< 95 (0,67)
	<i>Preloaded</i> Ball (N3/N4)	< 80 (0,56)	< 95 (0,67)	< 115 (0,81)	< 115 (0,81)	< 135 (0,95)
RS150100 1.500 inch dia. 1.000 inch lead	<i>Non-preloaded</i> Ball (N1/N2)	< 45 (0,32)	< 60 (0,42)	< 80 (0,56)	< 80 (0,56)	< 100 (0,71)
	<i>Preloaded</i> Ball (N3/N4)	< 90 (0,64)	< 105 (0,74)	< 125 (0,88)	< 125 (0,88)	< 145 (1,02)
RS150200 1.500 inch dia. 2.000 inch lead	<i>Non-preloaded</i> Ball (N1/N2)	< 60 (0,42)	< 75 (0,53)	< 95 (0,67)	< 95 (0,67)	< 115 (0,81)
	<i>Preloaded</i> Ball (N3/N4)	< 120 (0,85)	< 135 (0,95)	< 155 (1,09)	< 155 (1,09)	< 175 (1,24)

Support Housing Specifications

Support Housing Life millions of screw revolutions	Support Housing Thrust Load Capacity - (Axial)			
	Simple	Fixed (LT)	Fixed (HT)	Rigid
Static	4,380 (1987)	5,520 (2504)	11,700 (5307)	11,700 (5307)
1	4,380 (1987)	5,520 (2504)	8,060 (3656)	8,060 (3656)
2	3,475 (1576)	4,380 (1987)	6,400 (2903)	6,400 (2903)
10	2,035 (923)	2,565 (1163)	3,740 (1696)	3,740 (1696)
50	1,190 (540)	1,500 (680)	2,185 (991)	2,185 (991)
100	945 (429)	1,190 (540)	1,735 (787)	1,735 (787)
500	550 (249)	695 (315)	1,015 (460)	1,015 (460)

Thrust force applied in either direction

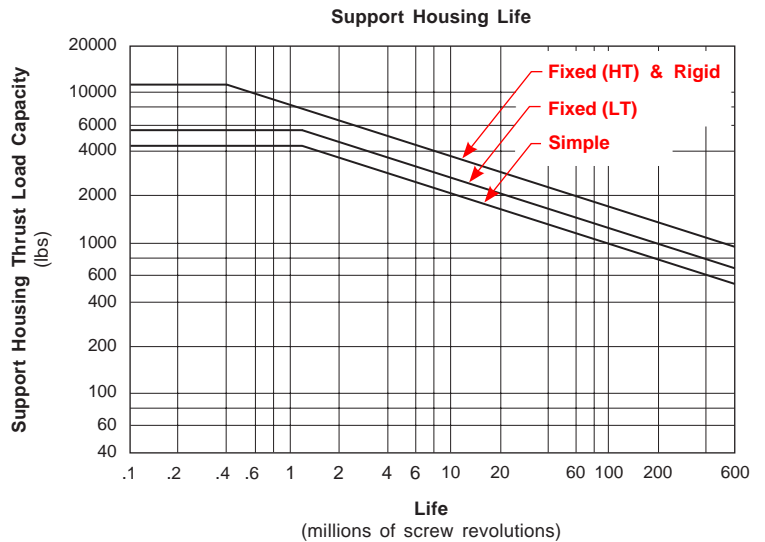
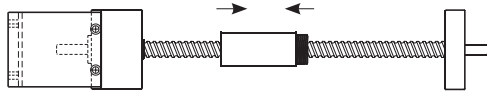

Note: Multiply screw revolutions by the screw lead in order to convert to inches (or mm) traveled by the nut.

Available Configurations

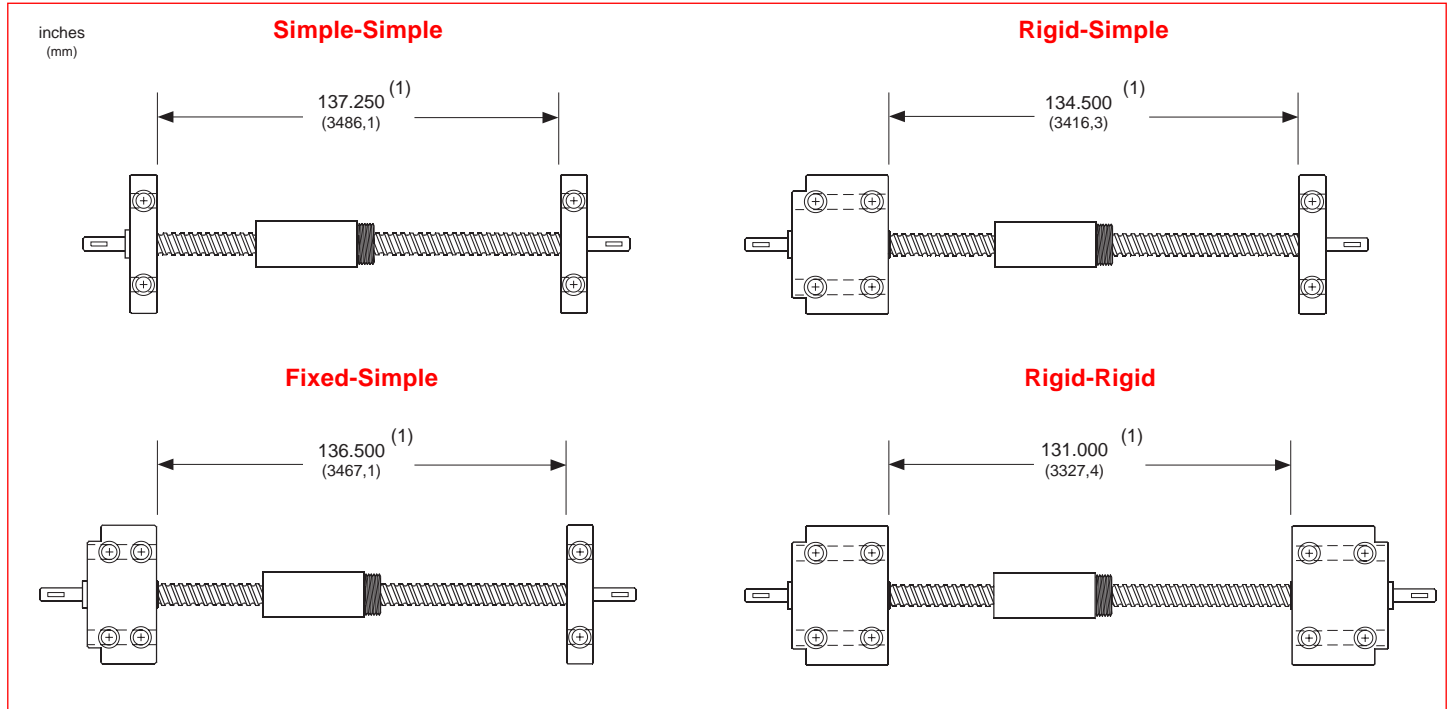

Overall Length Diagram

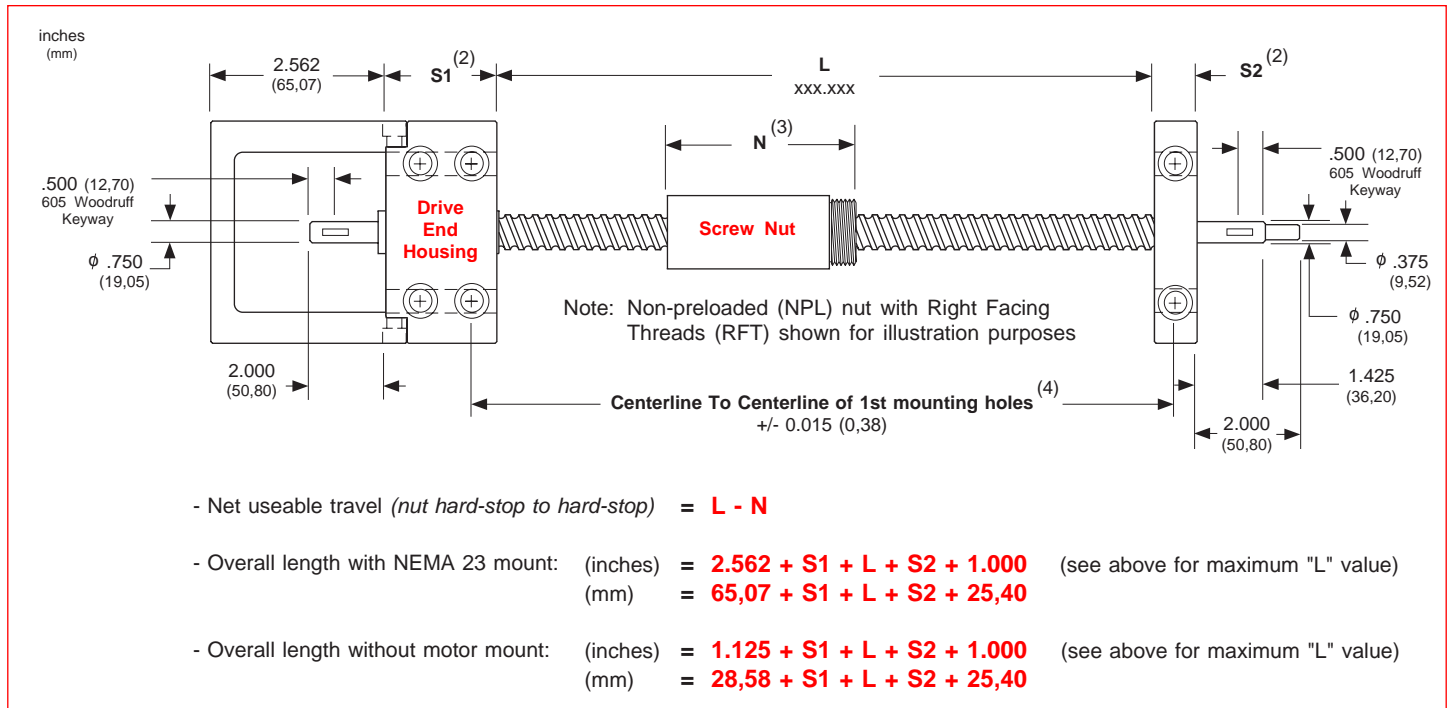

Footnotes:

- (1) Maximum available standard screw thread length for the bearing support housing configuration shown.
- (2) Fixed-simple support configuration shown for reference. See page 61 for length values for simple, fixed, and rigid housings.
- (3) See page 60 for available nut styles. Refer to A1 & A2 values for the nut length. See page 96 for wiper kit lengths.
- (4) Tolerance shown is for base mounted support housings. Tolerance also applies to face mounted support housings.

Performance Charts

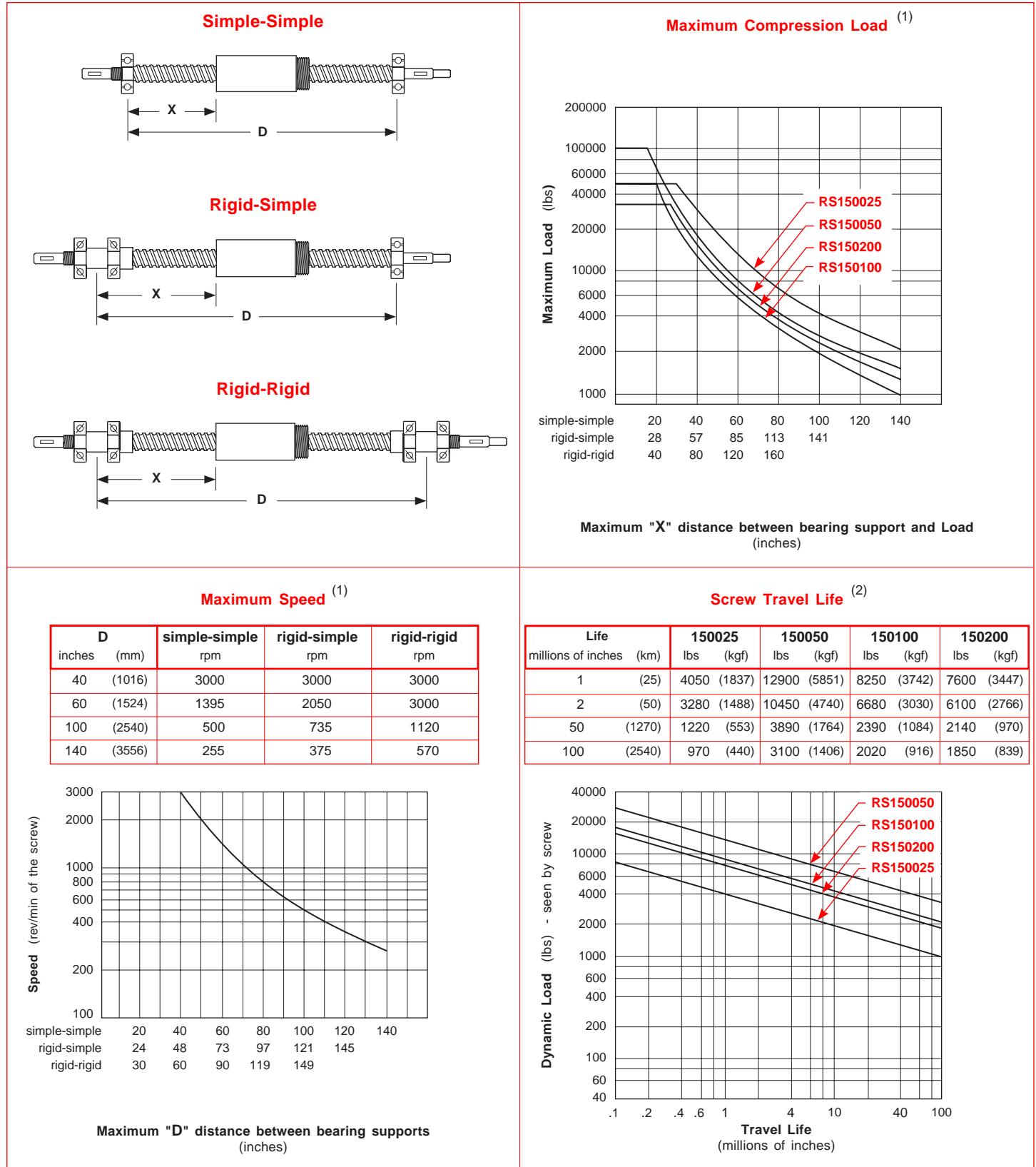

Footnotes:

- (1) Refer to the simple-simple support lengths for fixed-simple configurations. A fixed housing performs like a simple housing for critical speed and compression load specifications. Maximum speeds may not be reached using a Turcite nut due to system friction.
- (2) Multiply life value from chart (or graph) by 0.90 to obtain the life for a preloaded ball nut.

Nut Dimensions

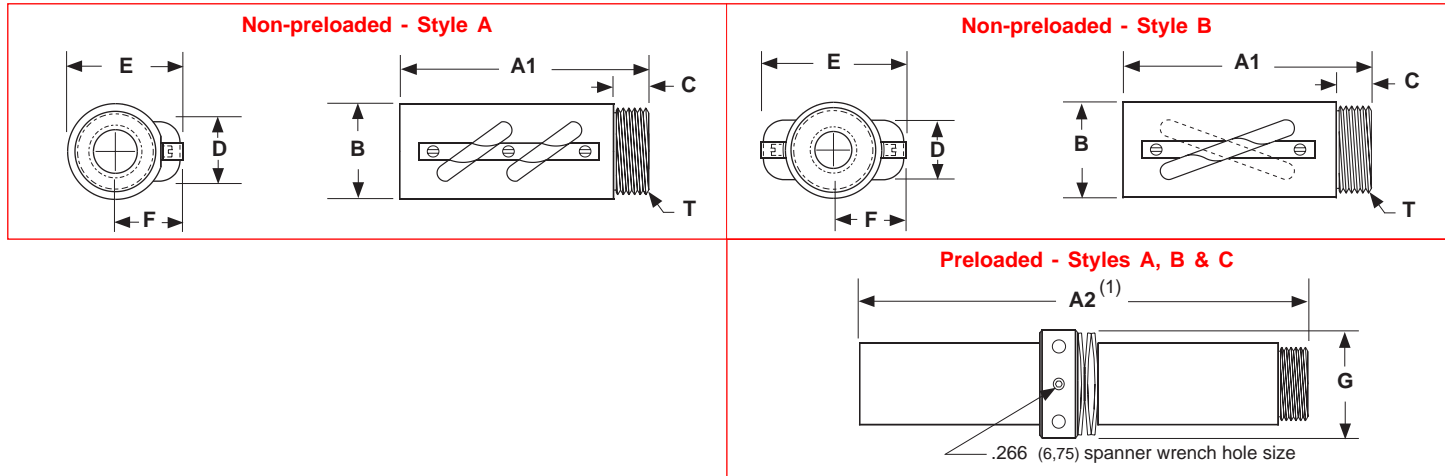

Nut Flange Dimensions

Round Flange

Weight = 3.3 lbs (1,5 kg)

(4) "L" Dia. Thru Holes on "K" Dia. BC

	H	J	K	L
RS150025	4.410 (112,0)	.760 (19,3)	3.500 (88,9)	.397 (10,08)
RS150050	4.650 (118,1)	.750 (19,1)	3.875 (98,4)	.531 (13,49)
RS150100	4.970 (126,2)	1.000 (25,4)	4.125 (104,8)	.531 (13,49)
RS150200				

Vertical Bracket

Weight = 2.0 lbs (0,9 kg)

(2) .75 (19,05) Deep Holes English (F2): 1/2-20 thd. Metric (F3): M12 thd.

	H	J	K	L
RS150025	3.875 (98,4)	2.313 (58,8)	.760 (19,3)	.380 (9,7)
RS150050	4.438 (112,7)	2.750 (69,9)	.750 (19,1)	.375 (9,5)
RS150100	4.438 (112,7)	2.750 (69,9)	1.000 (25,4)	.500 (12,7)
RS150200				

"L" Bracket

Weight = 4.0 lbs (1,8 kg)

(4) Holes English (F4): 1/2-20 thd. Metric (F5): M12 thd.

	H	J	K	L	M	N
RS150025	3.875 (98,4)	2.313 (58,8)	.760 (19,3)	4.250 (107,9)	.740 (18,8)	1.510 (38,4)
RS150050	4.438 (112,7)	2.750 (69,9)	.750 (19,1)	4.250 (107,9)	.625 (15,9)	1.500 (38,1)
RS150100	4.438 (112,7)	2.750 (69,9)	1.000 (25,4)	4.500 (114,3)	.625 (15,9)	1.750 (44,5)
RS150200						

Model Number	Nut Style	Nut Dimensions inches (mm)									Nut (3) Weight lbs (kg)
		A1	A2 ⁽¹⁾	B	C	D	E	F	T - "V" Threads ⁽²⁾	G	
RS150025	A	3.260 (82,80)	7.000 (177,80)	2.098 (53,29)	0.760 (19,30)	1.733 (44,02)	2.427 (61,65)	1.530 (38,86)	1.967 - 18 UNS-2A (49,96 - 18 UNS-2A)	2.420 (61,47)	2.75 (1,25)
RS150050	A	5.590 (141,99)	12.100 (307,34)	2.630 (66,80)	0.755 (19,17)	1.564 (39,73)	3.177 (80,70)	1.930 (49,02)	2.360 - 18 UNS-2A (59,94 - 18 UNS-2A)	3.114 (79,09)	5.50 (2,49)
RS150100	B	3.650 (92,71)	8.160 (207,26)	2.630 (66,80)	1.010 (25,65)	1.737 (44,12)	3.696 (93,88)	1.960 (49,78)	2 1/4 - 20 UN-2A (57,15 - 20 UN-2A)	3.114 (79,09)	3.25 (1,47)
RS150200	B	5.260 (133,60)	11.250 (285,75)	2.620 (66,55)	1.005 (25,53)	1.576 (40,03)	3.400 (86,36)	1.680 (42,67)	2 1/4 - 20 UN-2A (57,15 - 20 UN-2A)	3.114 (79,09)	5.25 (2,38)

Footnotes:

- (1) This is the length for a preloaded nut. Preloaded nut consists of two (2) non-preloaded nuts with a locking spanner nut, and belville springs.
- (2) All flange threads are internal (Type 2B) to match the external nut threads.
- (3) Weight of the non-preloaded nut. Multiply value by 2.1 to obtain the weight for the preloaded nut assembly.

Support Housing Dimensions

<p>inches (mm)</p> <p>1.000 (25,40)</p> <p>4.375 (111,12)</p> <p>3.375 (85,72)</p> <p>2.188 (55,57)</p> <p>.500 (12,70)</p> <p>2.688 (68,27)</p> <p>5.375 (136,52)</p> <p>(4) .531 (13,49) Dia. Thru Holes</p> <p>(4) 1/2-28 UNF x .75 (19,05) Deep on 3.500 (88,9) BC</p>	<p>Simple</p> <p>Weight = 5.0 lbs (2,27 kg)</p>	<p>.500 (12,70)</p> <p>1.000 (25,40)</p> <p>1.000 (25,40)</p> <p>(2) .531 (13,49) Dia. Thru Holes, .787 (19,99) Dia. C' Bored x .85 (21,59) Deep</p> <p>Drive End</p> <p>non-Drive End</p>
<p>1.000 (25,40)</p> <p>4.375 (111,12)</p> <p>3.375 (85,72)</p> <p>2.188 (55,57)</p> <p>.500 (12,70)</p> <p>2.688 (68,27)</p> <p>5.375 (136,52)</p> <p>.500 (12,70)</p> <p>(4) .531 (13,49) Dia. Thru Holes</p> <p>(4) 1/2-28 UNF x .75 (19,05) Deep on 3.500 (88,9) BC</p>	<p>Fixed</p> <p>Weight = 11.5 lbs (5,22 kg)</p>	<p>1.125 (28,57)</p> <p>.500 (12,70)</p> <p>1.000 (25,40)</p> <p>2.375 (60,32)</p> <p>(2) 10-32 x .44 (11,18) Deep, both sides</p> <p>(4) .531 (13,49) Dia. Thru Holes, .787 (19,99) Dia. C' Bored x .85 (21,59) Deep</p> <p>.188 (4,77)</p> <p>2.375 (60,32)</p>
<p>1.000 (25,40)</p> <p>4.375 (111,12)</p> <p>3.375 (85,72)</p> <p>2.188 (55,57)</p> <p>.500 (12,70)</p> <p>2.688 (68,27)</p> <p>5.375 (136,52)</p> <p>.500 (12,70)</p> <p>(4) .531 (13,49) Dia. Thru Holes</p> <p>(4) 1/2-28 UNF x .75 (19,05) Deep on 3.500 (88,9) BC</p>	<p>Rigid</p> <p>Weight = 21.2 lbs (9,62 kg)</p>	<p>3.125 (79,37)</p> <p>.500 (12,70)</p> <p>1.000 (25,40)</p> <p>4.375 (111,12)</p> <p>(2) 10-32 x .44 (11,18) Deep, both sides</p> <p>(4) .531 (13,49) Dia. Thru Holes, .787 (19,99) Dia. C' Bored x .85 (21,59) Deep</p> <p>2.375 (60,32)</p> <p>.188 (4,77)</p>
<p>NEMA 34 Motor Mount</p> <p>Weight = 4.0 lbs (1,82 kg)</p> <p>4.115 (104,52)</p> <p>4.063 (103,20)</p> <p>.563 (14,30)</p> <p>2.063 (52,40)</p> <p>5.375 (136,53)</p> <p>4.125 (104,78)</p> <p>2.063 (52,40)</p> <p>(4) Holes on 3.875 (98,42) BC Dia. English (M04): #10-24 thd. Metric (M05): M5 thd.</p> <p>2.876 (73,05) Pilot Dia. TYP</p> <p>(2) .221 (5,61) Dia. Thru Holes, .344 (8,74) Dia. C' Bored x .200 (5,08) Deep, both sides</p>	<p>NEMA 42 Motor Mount</p> <p>Weight = 4.0 lbs (1,82 kg)</p> <p>4.115 (104,52)</p> <p>4.063 (103,20)</p> <p>.563 (14,30)</p> <p>2.063 (52,40)</p> <p>5.375 (136,53)</p> <p>4.125 (104,78)</p> <p>2.063 (52,40)</p> <p>(4) Holes on 4.950 (125,73) BC Dia. English (M04): 1/2-20 thd. Metric (M05): M6 thd.</p> <p>2.189 (55,60) Pilot Dia. TYP</p> <p>(2) .221 (5,61) Dia. Thru Holes, .344 (8,74) Dia. C' Bored x .200 (5,08) Deep, both sides</p>	