

WLAN industrial Expansion Module for MAC motors. Type MAC00-EW4

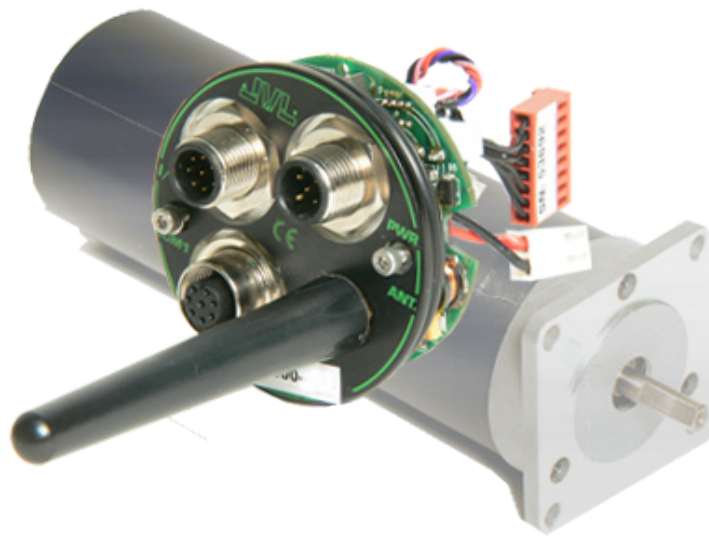

A range of integrated AC servo motors makes JVL a world leader within motion control. The numerous features of these motors include a modular concept that makes it extremely easy to adapt the motors to a very wide range of applications.

This wireless ethernet module MAC00-EW4 now makes it possible to use wireless control of the motors, giving total freedom of cables.

The module makes it possible to have a direct WLAN connection to the motor. Via the WLAN connection, the motor can be set-up and controlled with the same possibilities as offered by a serial connection. Functionality is exactly as with the MAC00-R4 module, but in-

stead of the serial connector the EW4 module is equipped with an antenna. The module can be programmed via MacTalk. Control is typical from a mobile phone or a PC. On a PC the program MacTalk can be used directly, or commands can be send from your own program.

The module furthermore has the possibility for connection of a local zero-set sensor. Connection of supply and signals takes place through 3 robust M12 connectors.

The module has a standard antenna plug connection, where the included antenna is connected. Other antennae

can be connected if required.

Applications:

- Positioning of axes.
- Supervision of motor.
- Parameter setup.

Function

- The solution gives full access to all functions and registers in the MAC motor.
- Baud rates of 19200
- Wireless control of the motor
- 4 In- and 4 Outputs
- Programmable via wireless control with MacTalk
- Supports both 802.11b and 802.11b/g standards
- Integrated WEB server
- No software driver needed

Block Diagram

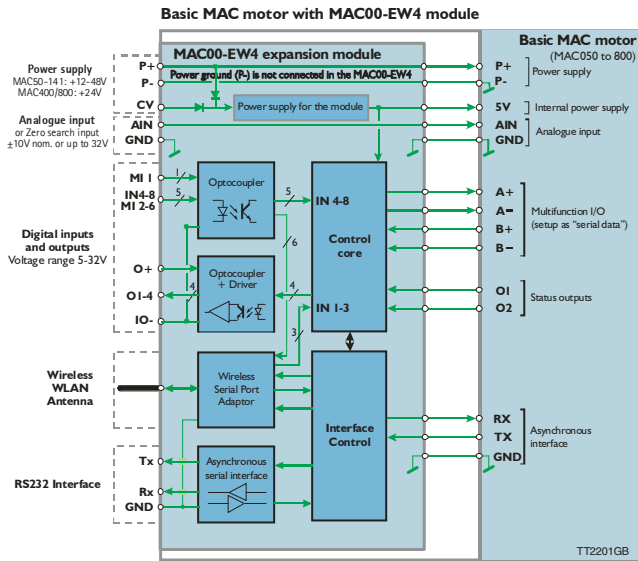

Pin Connections

"PWR" Power input. M12 – 5 pin male connector

Signal name	Description	Pin no.
P+	Main supply +12-48VDC.	1
P+	Main supply +12-48VDC	2
P-	Main supply ground	3
CV	Control voltage	4
P-	Main supply ground	5

"IO1" Basic I/O's. M12-8pin male connector

Signal name	Description	Pin no.
MI1	Mirror input I1	1
IN4/MI2	Digital input 4 and Mirror I2	2
IN5/MI3	Digital input 5 and Mirror I3	3
IN6/MI4	Digital input 4 and Mirror I4	4
O1	Digital output 1 - PNP output	5
O2	Digital output 2 - PNP output	6
O+	Output supply +5-32VDC. used for O1-4.	7
IO-	I/O ground. Used for IN4-8, MI1-MI4 and O1-4	8

"IO2" - Extended I/O's. M12 – 8pin female connector

Signal name	Description	Pin no.
IN7/MI5	Mirrored input A	1
RS232: Tx	RS232 Transmit	2
RS232: Rx	RS232 Receive	3
GND	Ground for AIN. This ground is shared with the main ground	4
O3	Digital output 3 - PNP output	5
O4	Digital output 4 - PNP output	6
AIN	Analog input +/-10V (also used for zero search sensor)	7
IN8/MI6	Digital input 8 and Mirror I6	8

Accessories

- MA0006: Antenna stand for relocation with 1m cable.
- MA0002: 70mm antenna on 3m cable.
- MA0004: Antenna, rugged stub. 1pcs. delivered together with the module

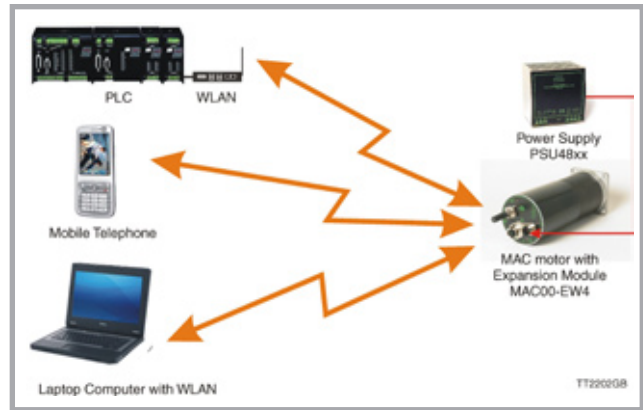

Examples of communication possibilities with the WLAN Expansion module. Note: Only one of the possibilities can communicate at a time.

Specifications

802.11 Specification:

Quality of service: Supports 802.11e and WMM.

Security: Supports 802.11i and WPA.

PHY/MAC:

802.11b and 802.11g. Extended rate protection. Regulatory domain support. Power save control. Defragmentation. Antenna diversity.

Infrastructure modes:

BSS. IBSS.

Security:

WEP64/128. WPA-EAP-TLS. WPA-PSK. WPA2-PSK. TKIP. CCM (AES).

Quality of service:

802.11e. WMM.

Software:

All software is included in the module.

Configurable locally or over WLAN using AT commands, PC wizard or MacTalk.

Additional Features:

TX power calibration. Link adaptation. Fragmentation. DTIM based power management.

Raw TCP. UDP. Http Tunneled. Secure HTTP (TLS). Secure TCP.

Ad-hoc and infrastructure mode. Integrated web server.

DHCP-client. DNS resolver. Integrated statistics logger. Web server with ASP. User configurable web pages.

Protocols:

TCP. UDP. HTTP. HTTPS. TCPS. Telnet.

Baud rate:

19200 bits/s.

Antenna connection:

SMA.



JVL Industri Elektronik A/S
 Blokken 42
 DK-3460 Birkerød, Denmark
 Tel: +45 4582 4440
 Fax: +45 4582 5550
 E-mail: jvl@jvl.dk www.jvl.dk

Sold & Serviced by
ELECTROMATE

Toll Free Phone (877) SERV098
 Toll Free Fax (877) SERV099
 www.electromate.com
 sales@electromate.com