

Controller



Controller

PS-24

RCM-PM

PMEC/AMEC

PSEP/ASEP

ROBONET

ERC2

PCON

ACON

PCON/ACON-ABU

SCON

PSEL

ASEL

SSEL

XSEL



PS241/PS242



RCM-PM-01



PMEC/AMEC



PSEP/ASEP



ROBONET



ERC2



PCON



ACON



PCON-ABU
ACON-ABU



SCON



PSEL



ASEL



XSEL

461

Controller

Sold & Serviced By:

ELECTROMATE

Toll Free Phone (877) SERV098

Toll Free Fax (877) SERV099

www.electromate.com

sales@electromate.com

PS-24	DC24V Power Supply for ROBO Cylinder	PS-241/242	471
RCM-PM	Touch Panel Display for Position Controller	RCM-PM-01	473
PMEC	3 Position Controller for RCP3/RCP2	PMEC-C	477
AMEC	3 Position Controller for RCA2/RCA/RCL	AMEC-C	
PSEP	3 Position Controller for RCP3/RCP2	PSEP-C / CW	487
ASEP	3 Position Controller for RCA2/RCA/RCL	ASEP-C / CW	
ROBONET	Network Controller for RCP3/RCP2/RCA2/RCA/RCL	RGW-DV / CC / PR / SIO RPCON / RACON / RABU / REXT	503
ERC2	ERC2 Controller	ERC2	515
PCON	Position Controller for RCP3/RCP2	PCON-C / CG / CY / PL / PO / SE	525
ACON	Position Controller for RCA2/RCA/RCL	ACON-C / CG / CY / PL / PO / SE	535
PCON-ABU ACON-ABU	Simple Absolute Unit for PCON/ACON Controller	PCON / ACON-ABU	545
SCON	Position Controller for RCS2	SCON-C	547
PSEL	Program Controller for RCP3/RCP2	PSEL-C	557
ASEL	Program Controller for RCA2/RCA/RCL	ASEL-C	567
SSEL	Program Controller for RCS2	SSEL-C	577
XSEL	Multiaxial Program Controller for RCS2	X-SEL-J / K / P / Q	587

Slider Type

Mini

Standard

Controllers Integrated

Rod Type

Mini

Standard

Controllers Integrated

Table/Arm /Flat Type

Mini

Standard

Gripper/ Rotary Type

Linear Servo Type

Cleanroom Type

Splash-Proof

Controller

PMEC /AMEC

PSEP /ASEP

ROBO NET

ERC2

PCON

ACON

SCON

PSEL

ASEL

SSEL

XSEL

Pulse Motor

Servo Motor (24V)

Servo Motor (200V)

Linear Servo Motor

- Slider Type
- Mini
- Standard
- Controllers Integrated
- Rod Type
- Mini
- Standard
- Controllers Integrated
- Table/Arm /Flat Type
- Mini
- Standard
- Gripper/ Rotary Type
- Linear Servo Type
- Cleanroom Type
- Splash-Proof
- Controllers**
- PMEC /AMEC
- PSEP /ASEP
- ROBO NET
- ERC2
- PCON
- ACON
- SCON
- PSEL
- ASEL
- SSEL
- XSEL
- Pulse Motor
- Servo Motor (24V)
- Servo Motor (200V)
- Linear Servo Motor

Controller Overview

The ROBO Cylinder model can be selected from an ultra-simple type, which is operable with the same controls as a solenoid valve, to a high functionality type compatible with networks; A variety of models are available according to the customer's usage.

Controller types can be categorized according to the 3 groups below based on their operations.

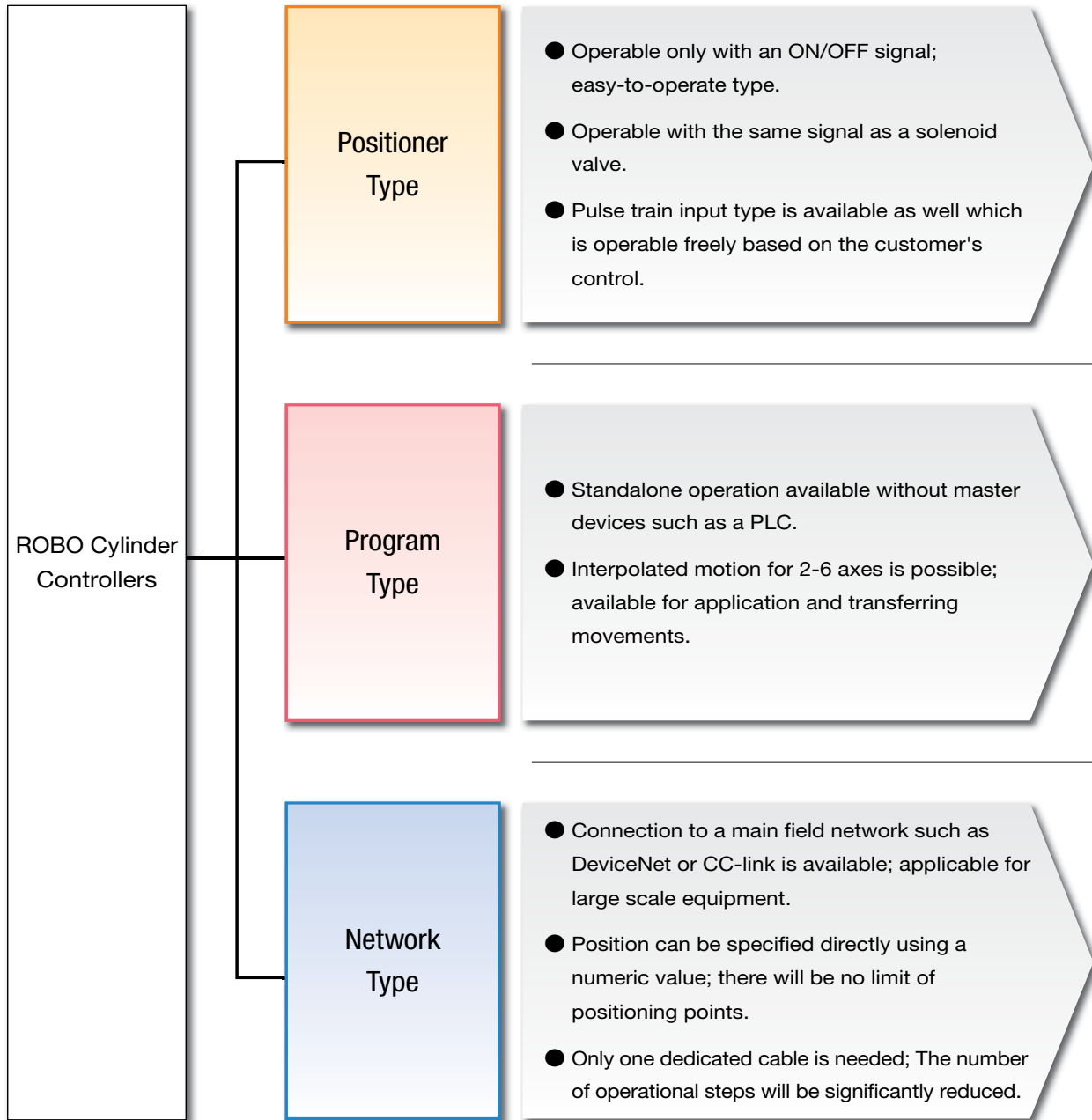

463 Controller



3-Position Controller
AC100V/AC200V Type
PMEC/AMEC



3-Position Controller
DC24V Type
PSEP/ASEP



Position Controller
DC24V/AC100V/AC200V Type
PCON/ACON/SCON

See page
465.



Program Controller
DC24V Type
PSEL/ASEL



Program Controller
AC100V/AC200V Type
SSEL/XSEL

See page
467.



Network Dedicated Controller
DC24V Type
RPCON/RACON



Network Compatible Controller
DC24V/AC100V/AC200V Type
PCON/ACON/SCON/PSEL/ASEL/SSEL/XSEL

See page
469.

- Slider Type
- Mini
- Standard
- Controllers Integrated
- Rod Type
- Mini
- Standard
- Controllers Integrated
- Table/Arm /Flat Type
- Mini
- Standard
- Gripper/ Rotary Type
- Linear Servo Type
- Cleanroom Type
- Splash-Proof
- Controllers**
- PMEC /AMEC
- PSEP /ASEP
- ROBO NET
- ERC2
- PCON
- ACON
- SCON
- PSEL
- ASEL
- SSEL
- XSEL
- Pulse Motor
- Servo Motor (24V)
- Servo Motor (200V)
- Linear Servo Motor

- Slider Type
- Mini
- Standard
- Controllers Integrated
- Rod Type
- Mini
- Standard
- Controllers Integrated
- Table/Arm /Flat Type
- Mini
- Standard
- Gripper/ Rotary Type
- Linear Servo Type
- Cleanroom Type
- Splash-Proof
- Controllers
- PMEC /AMEC
- PSEP /ASEP
- ROBO NET
- ERC2
- PCON
- ACON
- SCON
- PSEL
- ASEL
- SSEL
- XSEL
- Pulse Motor
- Servo Motor (24V)
- Servo Motor (200V)
- Linear Servo Motor

Positioner Type

The positioner type controller stores positions to which the actuator is moved by specifying a target position number.

In particular, PMEC/AMEC, PSEP/ASEP controllers specify 2 or 3 positions and can be operated with the same signals used for an air cylinder.

1 No programming needed

The positioner type controller operates by selecting the target position number externally using I/O after teaching the position data. Therefore, no operation programming is needed, allowing for immediate operation directly after mounting to the equipment.

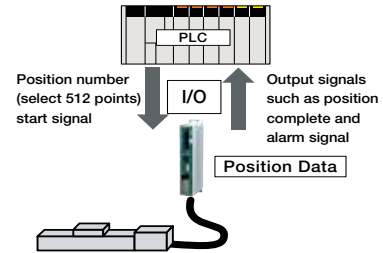

2 Operation using the same signal as solenoid valve possible (PMEC/AMEC, PSEP/ASEP controllers)

Same as single solenoid-type valve, traveling between front/back ends is possible only by the single ON/OFF. Furthermore, if the double solenoid-type valve signal (two signals) are used, positioning at 3 points including an intermediate position is possible.

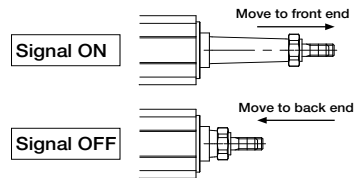

3 Reasonable price

A reasonable price range is offered for the pulse motor type controllers which maintain the effective functionality of a servo motor. The PMEC controller, including the power supply, PC software and communication cable, is sold as a set at a reasonable price.



4 No homing needed for absolute type and simple absolute type

A direct operation without homing upon power-on is possible if an absolute-type actuator and controller are used with the SCON Controller. Other controllers(*) are also operable without homing just like the absolute-type actuator by installing the simple absolute unit between the actuator and the controller.
 (*) Except PMEC/AMEC



465 Controller

PMEC/AMEC Controller

- Every element needed for operation such as the controller, power supply, PC software and communication cable, etc. are supplied in the set so that direct operation right after the purchase is possible.
- Intuitive operation is possible without the need for instruction. Acceleration/deceleration and speed can be programmed from the front panel of the controller.
- Operable with the same signals as a solenoid valve.
- Power supply of the controller is single-phase AC100V/AC200V (Only AC100V for AMEC)



See page
477.

PSEP/ASEP Controller

- Operable with the same signals as a solenoid valve.
- Splash-proof type having good resistance to water splashes.
- Simple absolute type setting which eliminates the need for homing upon power-on.
- Controller power supply: DC24V



See page
487.

PCON/ACON/SCON Controller

- Positioning is possible for up to 512 points.
- Compatible for pulse train input control.
- Incremental type and absolute type are available for the SCON. Same as the absolute type; no homing is needed for the PCON/ACON with an incremental type actuator using a simple absolute unit.
- Controller power supply is DC24V for PCON/ACON and single-phase AC100V/200V for SCON.



See page
525.



See page
535.



See page
547.

- Slider Type
- Mini
- Standard
- Controllers Integrated
- Rod Type
- Mini
- Standard
- Controllers Integrated
- Table/Arm /Flat Type
- Mini
- Standard
- Gripper/ Rotary Type
- Linear Servo Type
- Cleanroom Type
- Splash-Proof
- Controllers**
- PMEC /AMEC
- PSEP /ASEP
- ROBO NET
- ERC2
- PCON
- ACON
- SCON
- PSEL
- ASEL
- SSEL
- XSEL
- Pulse Motor
- Servo Motor (24V)
- Servo Motor (200V)
- Linear Servo Motor

- Slider Type
- Mini
- Standard
- Controllers Integrated
- Rod Type
- Mini
- Standard
- Controllers Integrated
- Table/Arm/Flat Type
- Mini
- Standard
- Gripper/Rotary Type
- Linear Servo Type
- Cleanroom Type
- Splash-Proof
- Controllers**
- PMEC/AMEC
- PSEP/ASEP
- ROBO NET
- ERC2
- PCON
- ACON
- SCON
- PSEL
- ASEL
- SSEL
- XSEL
- Pulse Motor
- Servo Motor (24V)
- Servo Motor (200V)
- Linear Servo Motor

Program Type

The program type controller executes programs that are input to it.

Programs input to the controller are used to perform various tasks such as operating the actuator and communicating with external equipment. Ideal for small systems where a PLC is not required which leads to cost savings.

1 High-level control available using simple language.

A program is generated for the program type controller using the simple and easy Super SEL Language to execute operation of the actuator and communication between peripheral equipment.

Expert knowledge is not needed to use the Super SEL Language, so it's easy to create programs even for beginners.

No.	B	E	N	Cnd	Cand	Operand 1	Operand 2
1					HOME	100	
2					HOME	11	
3					VEL	200	
4					WTON	1	
5					MOYL	1	
6					BTON	301	
7					WTON	2	
8					BTOF	301	
9					MOYL	2	
10					BTON	302	

2 Interpolation possible up to 2/6 axes

Simultaneous movement of the actuators are possible up to 2 axes for PSEL/ASEL/SSEL controllers and 6 axes for the XSEL controller.

Depending on the program, interpolation is available to easily perform arc or path movements needed for dispensing jobs.

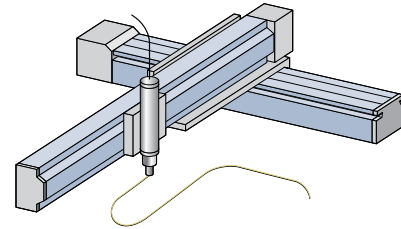

3 Controlling external equipment is possible

Multi-purpose I/O signals are available for the controller which makes communication with peripheral equipment possible.

Therefore, receiving signals from sensors and such through the controller or outputting signals from the controller to lamps or moving equipment, etc. to operate them is possible.

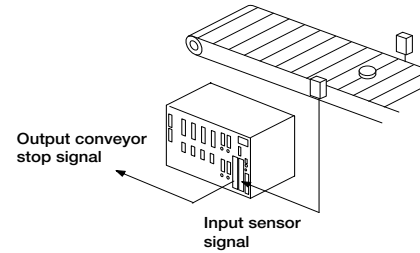

4 No homing needed for absolute type and simple absolute type

A direct operation without homing is possible upon power-on if an absolute-type actuator and controller are applied for ASEL/SSEL/XSEL Controllers.

The PSEL controller is also operable without homing just like an absolute-type actuator by installing the simple absolute unit between the actuator and the controller.



467

Controller

PSEL/ASEL/SSEL Controller

- Program controller with reasonable price and compact body.
- Interpolation of up to 2 axes is possible which is applicable for dispensing jobs.
- By selecting the positioner mode, can be used in the same manner as the position controller.
- Communication via PC USB port and direct USB cable is possible with integrated USB port.
- Can store up to 1500 points for PSEL/ASEL and 20000 points for SSEL.
- Absolute type available for ASEL/SSEL controllers. PSEL controller is available for the same operation if a simple absolute unit is connected.
- Controller power supply is DC24V for PSEL/ASEL and single-phase AC100V/200V for SSEL.



See page
557.



See page
567.



See page
577.

XSEL Controller

- High-function controller with up to 6 axes that can be simultaneously controlled.
- Precise dispensing jobs are possible through high velocity uniformity and tracking accuracy.
- Absolute type available for selection.
- 20000 points can be stored for positioning.
- Expansion I/O is available up to a maximum of 384 points.
- P/Q type controls PCON/ACON/SCON/ROBONET via serial communication for up to 16 axes. (→ Refer to Gateway function p469)
- Controller power supply is single-phase AC100V/200V for XSEL-J/K type and three-phase AC200V for XSEL-P/Q type.



See page
587.

Slider Type

Mini

Standard

Controllers Integrated

Rod Type

Mini

Standard

Controllers Integrated

Table/Arm /Flat Type

Mini

Standard

Gripper/ Rotary Type

Linear Servo Type

Cleanroom Type

Splash-Proof

Controllers

PMEC /AMEC

PSEP /ASEP

ROBO NET

ERC2

PCON

ACON

SCON

PSEL

ASEL

SSEL

XSEL

Pulse Motor

Servo Motor (24V)

Servo Motor (200V)

Linear Servo Motor

Network Type

The network type controller is available for field networks or serial communication.

Compatible with the majority of main field networks widely used over the world.

There is a large variety available for use with various kinds of FA equipment such as a PLC or touch panel, etc.

1 Compatible with main field networks

Direct connection is possible with main field networks such as DeviceNet or CC-Link, etc.

A position controller is available for an operation defined by movement specified with position number and direct coordinate value using the network. When defining coordinate values directly, there is no restriction for the number of positioning points.

Compatible Network and Function

Controller series		ROBONET	PCON	ACON	SCON	PSEL	ASEL	SSEL	XSEL
Network Type	DeviceNet	○	○	○	○	○	○	○	○
	CompoNet		○	○					
	CC-Link	○	○	○	○	○	○	○	○
	MECHATROLINK		○	○					
	PROFIBUS-DP	○	○	○	○	○	○	○	○
	Ethernet								○
Applicable ROBO Cylinder		RCP2/RCP3 RCA/RCA2/RCL	RCP2/RCP3	RCA/RCA2/RCL	RCS2	RCP2/RCP3	RCA/RCA2/RCL	RCS2	RCS2
Number of positioning points		768 points (*)	768 points (*)	768 points (*)	512 points	1500 points	1500 points	20000 points	20000 points
Operating Method	Movement by specifying positions	○	○	○	○	○	○	○	○
	Movement by specifying direct values	○	○	○	×	×	×	×	×

(*) When it is operated by movement by specifying direct values, the number of positioning points is unlimited.

2 RC Gateway function for XSEL controller

The ROBO cylinder gateway function controls the ROBO cylinder via serial communication from the XSEL controller. Wiring work is significantly reduced, comparing with PIO control. The ROBO cylinder can be operated using the XSEL controller via the SEL Language.

- ROBO Cylinder gateway function is available in the controller firmware (main CPU application) V0.68 or higher (for P/Q type), or V0.34 or higher (for PX/QX type).
- The version of the PC software (IA-101-X-MW) that is compatible with the ROBO Cylinder gateway function is V7.2.0.0 or later.
- The teaching pendants compatible with the ROBO Cylinder gateway function are IA-T-X (XD) V1.4.6 or later, or SEL-T (TD) V1.0.1 or later.

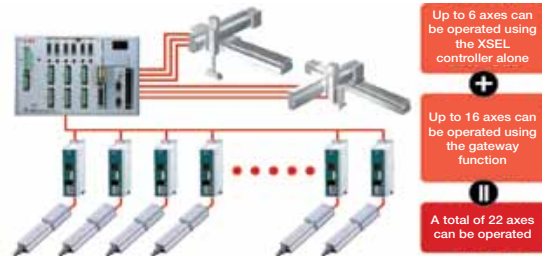

(Comparison of PIO Control and Gateway function)

	PIO control	Gateway function
Wiring process	Many wires	Only two wires
Control method	Only ON/OFF of I/O	Program available
Movement position	Requires input into controller ahead of time	Can send command from XSEL controller
Current actuator position	Verify with end position No.	Can numerically check current position

Type

Item	Description
Number of maximum connected axes for ROBO Cylinder	16 axes
Number of maximum operation axes for XSEL Controller	6 axes
Available ROBO Cylinder series	ERC2 / RCP2 / RCP3 / RCA / RCA2 / RCS2
Connectible controller	ERC2 / PCON / ACON / SCON / ROBONET
Communication system	Modbus

Connectible Units

The following units are required to use the ROBO Cylinder Gateway function. Please contact us for further details for wiring.

Name	Model	Notes
RS232 conversion unit	RCB-CV-GW	1 unit needed for each XSEL controller.
Communication cable	CB-RCB-SIO050	1 cable needed for each XSEL controller.
Controller link cable	CB-RCB-CT002	1 cable needed for each ROBO Cylinder controller to be connected.

3 Connection with various types of FA equipment

Available for direct connection with a touch panel, PLC (serial communication unit) or vision system of various manufacturers.

■ **Main Connecting Equipment** * Please contact us for further details for connectable equipment, etc.

Name of product	Manufacturer
Touch Panel	Digital, Omron, Hakko Electronics, Keyence, Mitsubishi Electric, Beijer, Proface, Red Lion
PLC (Serial communication)	Omron, Mitsubishi Electric, Keyence
Vision System	Omron, Cognex, Keyence

ROBONET Controller

- ROBONET is a controller dedicated for field networks.
Wiring was reduced significantly as it can be connected with up to a maximum of 16 control units for a single gateway unit which is compatible with various networks.
- Operation is available with target position, speed or acceleration, etc. sent through a network by means of a value; this is effective when target position changes based on conditions.
- Simple absolute unit can be installed to make homing unnecessary.
- Controller power supply; DC24V



See page
503.

Controller compatible with field network * Network type set for each controller



See page
525.



See page
535.



See page
547.



See page
557.



See page
567.



See page
577.

- Can be connected to the main network directly.
- The position controller is able to be operated with the value of the target position, speed or acceleration etc. directly sent via the network.



See page
587.

Controller **470**

- Slider Type
- Mini
- Standard
- Controllers Integrated
- Rod Type
- Mini
- Standard
- Controllers Integrated
- Table/Arm /Flat Type
- Mini
- Standard
- Gripper/ Rotary Type
- Linear Servo Type
- Cleanroom Type
- Splash-Proof
- Controllers**
- PMEC /AMEC
- PSEP /ASEP
- ROBO NET
- ERC2
- PCON
- ACON
- SCON
- PSEL
- ASEL
- SSEL
- XSEL
- Pulse Motor
- Servo Motor (24V)
- Servo Motor (200V)
- Linear Servo Motor

- Slider Type
- Mini
- Standard
- Controllers Integrated
- Rod Type
- Mini
- Standard
- Controllers Integrated

PS-24



■ Model PS-241/PS-242

DC24V Power supply for ROBO Cylinder

- Table/Arm /Flat Type

Features

1 Maximum Momentary Output of 17A

Up to 17A of maximum momentary output current is possible at 8.5A rated output current. This lets you select an appropriate power-supply capacity based on the total rated current of actuators, without having to consider the maximum momentary current that may be generated by the actuators during acceleration. Because you no longer need to use an expensive high-capacity power supply, cost can be reduced substantially.

* The maximum momentary output current must be considered if the actuator operating conditions are tight. See the "Selection Guide" at right for details.

2 Parallel Operation Enabled

Up to 5 units can be operated in parallel. Therefore, even if the power capacity is insufficient with one unit, this can be easily remedied by adding one unit, without the need to replace the unit with a larger capacity power supply.

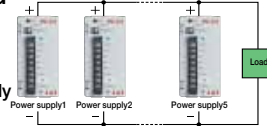

3 Load Detection Function

Load percentage can be detected by the RDY (Ready) display lamp and the RDY output signal.

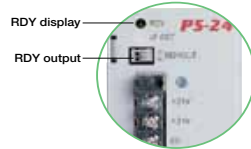

Table 1. PS-24 Rated Current and Allowable Maximum Momentary Electric Current

No. of Connected units	Rated current [A]	Max. momentary current [A]
1	8.5	17
2	15.3	30.6
3	22.95	45.9
4	30.6	61.2
5	38.25	76.5

Note: For the second and subsequent units, add a 10% safety buffer (loss).

Selection target Number of actuators connected

When selecting a power-supply unit for operating multiple actuators, normally a unit with a capacity equal to or exceeding the total maximum current of all actuators is chosen. However, actuators generate their maximum current only momentarily during acceleration, etc., and in many cases the power-supply is over-specified.

On the other hand, the PS-24 power supply provides the following advantages:

1. Supporting maximum momentary current of up to twice the rated current.
2. If you need more power-supply capacity, you can simply add an extra unit or units.

The above features let you select an optimal power-supply capacity.

Number of Power-Supply Units

Basically, how many power-supply units you need should be determined in such a way that the total rated current of all actuators will remain within the rated current of the PS-24. If the load condition is tight, however, the power-supply capacity may still become inadequate. In such cases, add an extra power supply or supplies.

"Severe load conditions" refers to:

- Large load (load is approaching the rated load capacity)
- High acceleration/deceleration
- High speed
- Simultaneous operation of multiple axes
- Use of the RCS2-SRA7 series (Structurally these actuators allow maximum current to flow for a longer period).

Table 2. Actuator vs. Power Supply Current

Controller Type	Actuator Type	Power supply current [A]		Number of Connectable Units for PS-24 (Reference)*1	
		Rated (=Maximum)	Maximum	If the servo is on for all axes simultaneously	If the servo is NOT on for all axes simultaneously
ERC2	ERC2	Rated (=Maximum)	2	8	8
PSEP RPCON PCON	All models of RCP3/RCP2 (* Excluding the 5 models below)	Rated (=Maximum)	6	2	2
PCON-CF	RCP2-HS8C / RCP2-HS8R RCP2-RA10C RCP2W-RA10C / RCP2W-SA16C	Rated	1.3	3	6
		Maximum	4.4		
ASEP RACON ACON	SA4, SA5 (20W)	Rated	1.3	4	6
		Maximum	4		
	SA6 (30W)	Rated	1.7	3	5
		Maximum	5.1		
RA4 (20W)	RA4 (20W)	Rated	1.3	3	6
		Maximum	4.4		
RA4 (30W)	RA4 (30W)	Rated	1.3	4	6
		Maximum	4		

*1 The figures in "Number of Connectable Units for PS-24 (Reference)" are calculated based on the following: When supplying power to multiple controllers, make sure that the sum of the rated current for the individual axes stays LOWER than the PS-24's rated current (8.5A). Exceptions: For RCP3/RCP2/RCP2W, make sure that the sum of the rated current for the individual axes is LOWER than the PS-24's maximum momentary current (17A).

For PSEL/ASEL, this varies with number of axes used and the model. Please ask for details.

- Mini

- Standard

- Cripper/ Rotary Type

- Linear Servo Type

- Cleanroom Type

- Splash-Proof

- Controllers

- PMEC /AMEC

- PSEP /ASEP

- ROBO NET

- ERC2

- PCON

- ACON

- SDON

- PSEL

- ASEL

- SSEL

- XSEL

- Pulse Motor
- Servo Motor (24V)
- Servo Motor (200V)
- Linear Servo Motor

Names

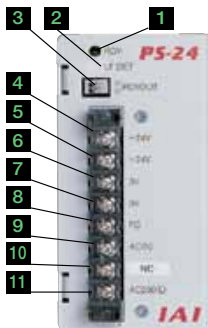

1 Ready indicating light (RDY)

2 Level setting dial for over load detection (LF.DET)

*Appropriate value settled at shipment. Operation not needed.

3 Ready output signal (RDYOUT)

4 5 + 24V Output terminal (+ 24V)

*④⑤ connected internally.

6 7 0V Output terminal (0V)

*⑥⑦ connected internally.

8 Frame ground terminal (FG)

Terminal for ground.

9 AC input terminal (AC (N))

10 AC input terminal (AC100V) (AC100 (L))

11 AC input terminal (AC200V) (AC200 (L))

*AC100V input type should be connected to ⑨ and ⑩ interval, AC200V to ⑨ and ⑪. Unavailable for combined use.

471 PS-24

List of Models

Model	PS-241	PS-242
Standard Price	-	-

Specification List

Item	PS-241	PS-242
Rated DC output voltage	24V±10% (varied depending on the load)	
Rated DC output current	8.5A	
Instantaneous max. output current	17A	
Rated output capacity	204W	
Efficiency	80%	
Rated input (frequency)	AC100~115V (50/60Hz)	AC200~230V (50/60Hz)
Input voltage range	AC85~125V	AC170~250V
Input current	3.50A (100VAC full load)	1.80A (200VAC full load)
Output holding time	20 [msec] (Ambient temperature 25°C under rated input/output condition)	
Protection circuit	Protection from overcurrent, overvoltage, overheating and overload.	
Parallel operation	Possible	
Operating temperature	0~50°C (derated)	
Operating humidity	30~85%RH (non-condensing)	
Cooling method	Natural, air cooling	
Voltage resistance	Between input/output--2.0kVA per minute (20mA) Between cabinets--2.0kVA per minute (20mA)	
Insulation resistance	Output - 100MΩ or more between cabinets at 500 VDC	
Circuit method	Separate excitation type flyback converter	
Weight	Approx. 0.9kg	

Outer dimensions

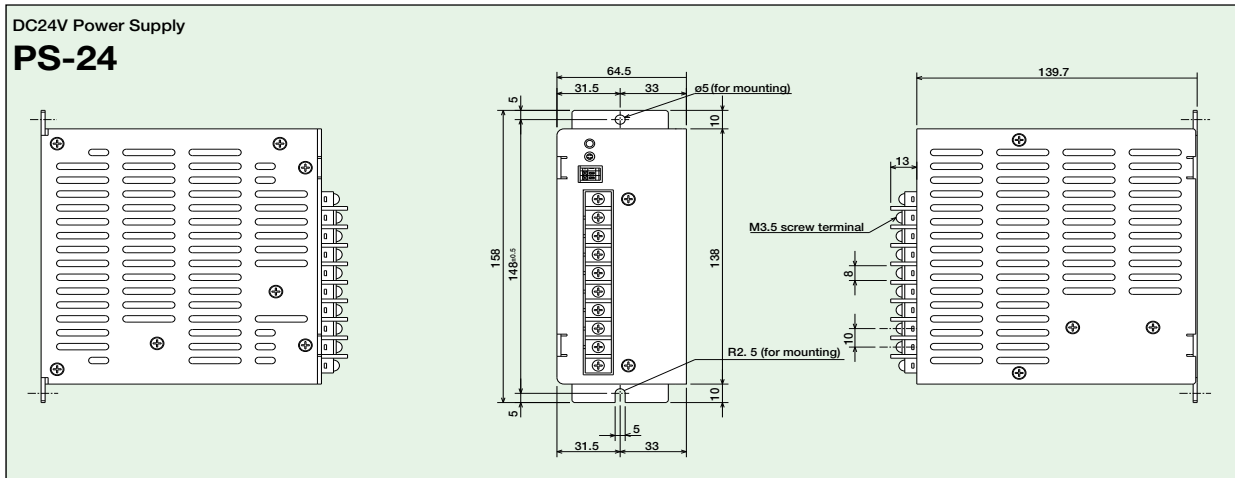

Caution:

- The PS-24 is not a constant voltage power supply. The output voltage changes with the load (voltage decreases according to the load percentage). Therefore, do not connect any equipment other than ROBO Cylinder actuators.
- Up to 5 units can be operated in parallel. Do not use any power supplies other than the PS-24 at the same time for parallel operation.
- Note that serial operations are not possible.
- As a rule, when operating multiple units in a row, allow at least 20mm space between each power supply.
- This is a natural air-cooled power supply. Please give due consideration to natural convection so that heat does not build up around the power supply.
- The case of this product also has heat a dissipating effect. Do not touch the case after installation as it may result in severe burns.

- Slider Type
- Mini
- Standard
- Controllers Integrated
- Rod Type
- Mini
- Standard
- Controllers Integrated
- Table/Arm /Flat Type
- Mini
- Standard
- Cripper/ Rotary Type
- Linear Servo Type
- Cleanroom Type
- Splash-Proof
- Controllers**
- PMEC /AMEC
- PSEP /ASEP
- ROBO NET
- ERC2
- PCON
- ACON
- SCON
- PSEL
- ASEL
- SSEL
- XSEL
- Pulse Motor
- Servo Motor (24V)
- Servo Motor (200V)
- Linear Servo Motor

- Slider Type
- Mini
- Standard
- Controllers Integrated
- Rod Type
- Mini
- Standard
- Controllers Integrated
- Table/Arm /Flat Type
- Mini
- Standard
- Gripper/ Rotary Type
- Linear Servo Type
- Cleanroom Type
- Splash-Proof
- Controllers
- PMEC /AMEC
- PSEP /ASEP
- ROBO NET
- ERC2
- PCON
- ACON
- SCON
- PSEL
- ASEL
- SSEL
- XSEL
- Pulse Motor
- Servo Motor (24V)
- Servo Motor (200V)
- Linear Servo Motor

RCM-PM-01



■ Model RCM-PM-01

Position controller
Touch panel display

Characteristics

1 Controller data is easy to enter, amend or monitor.

Entering, changing and monitoring (of actual position, speed or input/output condition, etc.) controller position data is possible without connecting teaching box or computer software if touch panel display is installed on the device. (*1)
Easy-to-use even for beginners as the display is interactive.
(* 1) Teaching box or software for PC is needed to reset error or change parameter.



NOT FOR SALE IN

2 Able to check the current condition at a glance with 3 back lights of good visibility.

Improvement with an easy-to-use color display back light. Color change that changes operation for three step color normal, alarm and emergency stop. Indicators white, pink and red respectively; this makes it very easy to identify current situation.

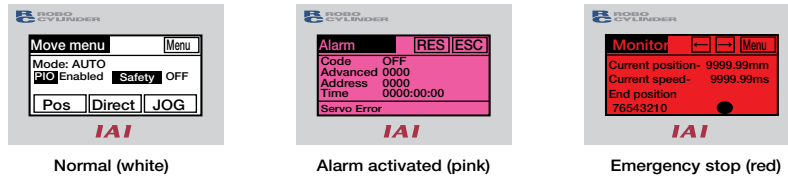

3 Able to display current position, speed, electric current value and alarm up to 4 axes simultaneously when connected with ROBONET.

Displays controller condition of ROBONET simultaneously up to 4 axes when connected with ROBONET Gateway unit. (Able to display up to 16 axes by switching the panel.)
The details of the display show the actual position of the operating actuator, speed, electric current value, alarm code, etc.



Model/Price

Model	RCM-PM-01
Standard Price	-

473

RCM-PM-01

Connecting methods

[When Connecting to the Controller's Power Source]

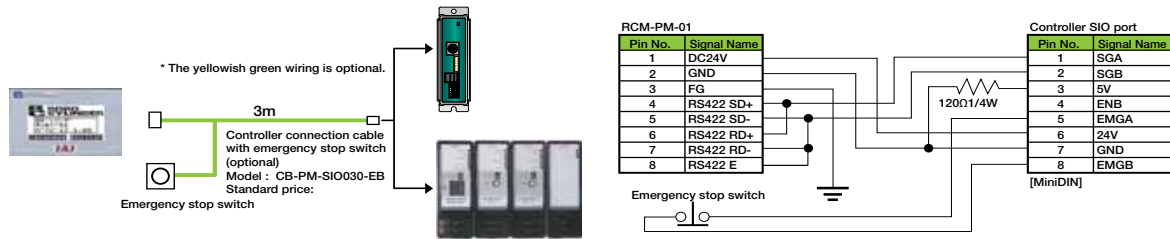

[When Connecting to a Separate Power Source]

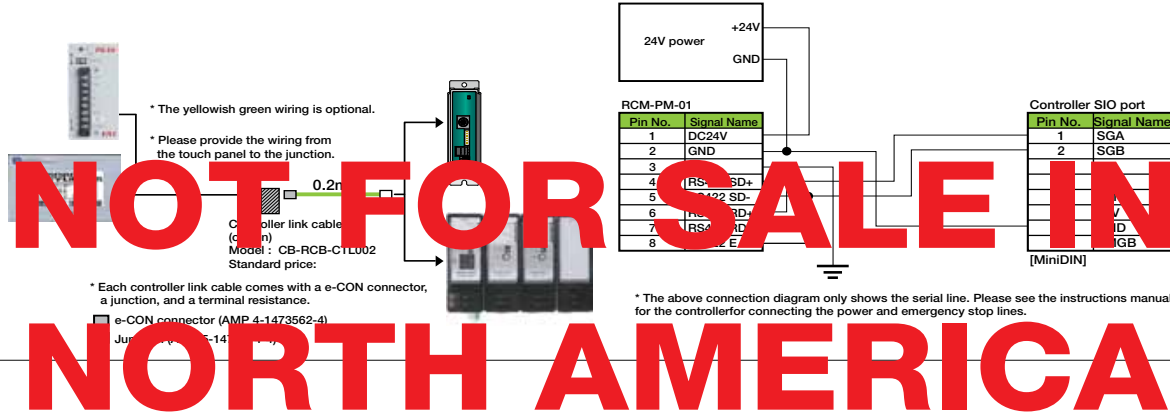

[When Connecting to Multiple Controllers]

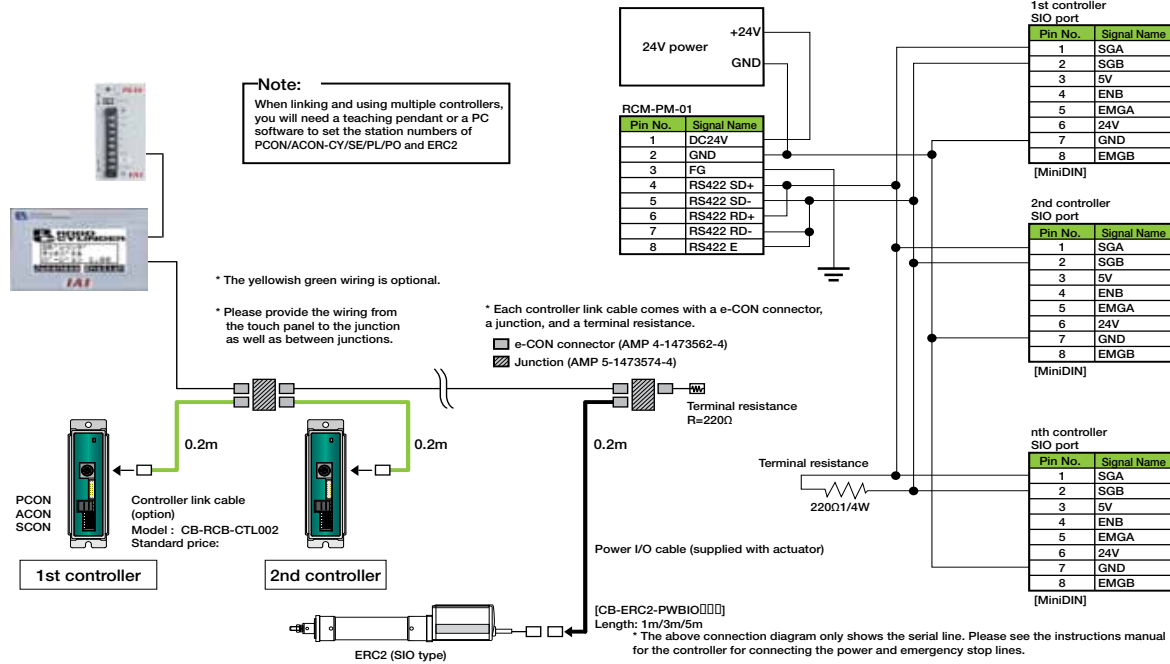

- Slider Type
- Mini
- Standard
- Controllers Integrated
- Rod Type
- Mini
- Standard
- Controllers Integrated
- Table/Arm /Flat Type
- Mini
- Standard
- Gripper/ Rotary Type
- Linear Servo Type
- Cleanroom Type
- Splash-Proof
- Controllers
- PMEC /AMEC
- PSEP /ASEP
- ROBO NET
- ERC2
- PCON
- ACON
- SCON
- PSEL
- ASEL
- SSEL
- XSEL
- Pulse Motor
- Servo Motor (24V)
- Servo Motor (200V)
- Linear Servo Motor

Model/Specification

Model		RCM-PM-01
Standard Price		
Basic Specifications	Rated Voltage	DC24V
	Operational Voltage Range	DC21.6~26.4V
	Power Consumption	2W or less (80mA or less)
	Operating Ambient Temp./Humidity	0~50°C 20~85% RH (non-condensing)
	Environment resistance	IP65 (initial state) dust- and splash-proof, only from front side of the panel
	Mass	Approx. 160g
Communications Specifications	Communications Standard	RS485 Compliant
	Communication Conditions	Transfer speed: 115.200bps, Data bit: 8-bit, Non-parity, Stop bit; 1-bit
	Protocol	Modbus/RTU
	Connectible Controllers	PCON/ACON/SCON/ERC2/ROBONET *Connectible up to 16 controllers max.
function	Monitor	Current position, current speed, alarm code, alarm message PIO status bit, speed wave form, current wave form, current, rated current ratio
	Alarm list	History: 16 entries (code, detailed code, address occurred, message)
	Position table edit	Target position, position, acceleration, positioning width, pushing, separate zones, incremental setting, threshold, accel/decel. mode Stop mode, importing current position via JOG/inching/direct teaching, warning function for abnormal input value
	Move function	Position movement, direct movement, JOG movement, jump-to-screen function when alarm is triggered
	Edit parameters	Zone signal, software limit, select PIO pattern, JOG speed, inching distance, pushing force, safety speed
	Backlight	White (normal), Pink (alarm triggered), red (emergency stop)
	Display adjustments	Adjustable contrast and brightness for the backlight
	Gateway Monitor Functions	Current position, current speed, alarm code, alarm message for 4 axes, current for all axes, alarm monitor for 4 axes, Gateway system s

NOT FOR SALE IN NORTH AMERICA

Dimensions

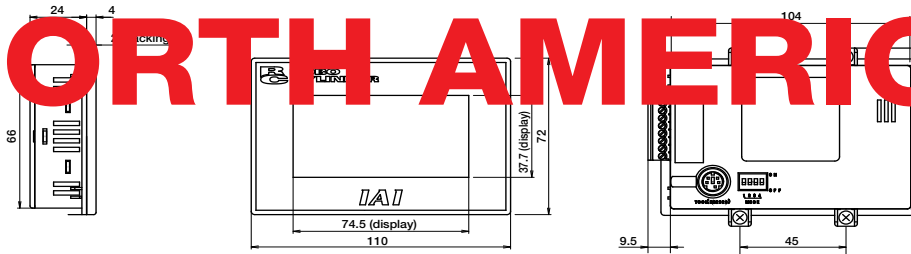

Example of body installation

■ Dimensions for Cutting and Drilling Holes

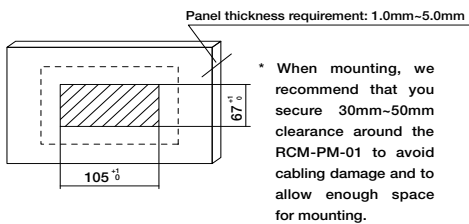

Caution Never block the slits on the actuator.

■ Mounting Method (Using Supplied 4 Mounting Brackets)

- ① Insert the RCM-PM-01 to the mounting plate.
 - ② Attach the mounting brackets to the slots on RCM-PM-01, and secure the RCM-PM-01 onto the mounting place by tightening the screw.
- Note 1) Screw tightening torque 0.1 N·m-0.25N·m
Note 2) Excessive tightening of the screws may warp the front panel, causing the touch switches to malfunction. Please mount using appropriate torque.

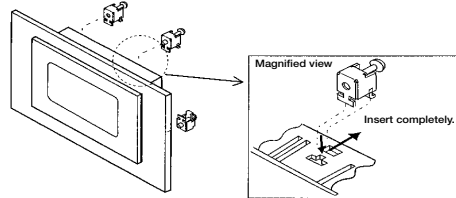

475 RCM-PM-01

Serial Communication Option

Please use the options below to connect controller by link through serial communication.

SIO Converter

RS232 communication available transformer with serial communication cable of power supply and I/O cable(SGA, SGB) connected and pin-cross cable D-Sub9 for connecting PC used.

Characteristics Able to separate the connecting point for teaching box or PC connection cable from the body and install them anyway.

Able to operate through PC serial communication by connecting multiple axes.

type	Item	type
	Power supply voltage	DC24V±10%
	Ambient Operating Temp./Humidity	0 ~ 50°C, 85% RH or less (Non-condensing)
	Terminator	120Ω(Integrated)

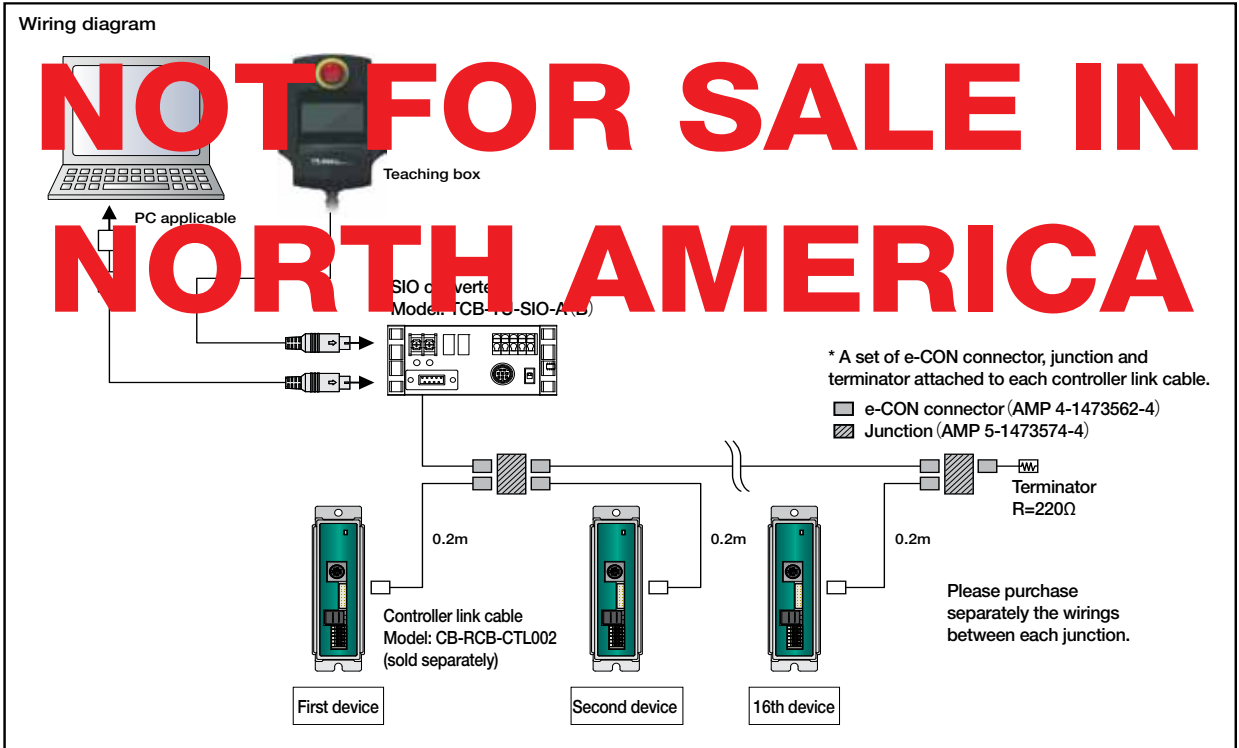
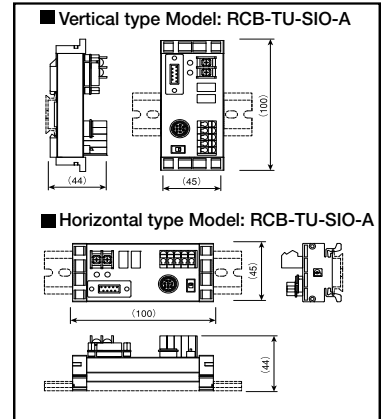

- Slider Type
- Mini
- Standard
- Controllers Integrated
- Rod Type
- Mini
- Standard
- Controllers Integrated
- Table/Arm /Flat Type
- Mini
- Standard
- Gripper/ Rotary Type
- Linear Servo Type
- Cleanroom Type
- Splash-Proof
- Controllers
- PMEC /AMEC
- PSEP /ASEP
- ROBO NET
- ERC2
- PCON
- ACON
- SCON
- PSEL
- ASEL
- SSEL
- XSEL
- Pulse Motor
- Servo Motor (24V)
- Servo Motor (200V)
- Linear Servo Motor

- Slider Type
- Mini
- Standard
- Controllers Integrated
- Rod Type
- Mini
- Standard
- Controllers Integrated
- Table/Arm /Flat Type
- Mini
- Standard
- Gripper/ Rotary Type
- Linear Servo Type
- Cleanroom Type
- Splash-Proof
- Controllers
- PMEC /AMEC**
- PSEP /ASEP
- ROBO NET
- ERC2
- PCON
- ACON
- SOON
- PSEL
- ASEL
- SSEL
- XSEL
- Pulse Motor
- Servo Motor (24V)**
- Servo Motor (200V)
- Linear Servo Motor

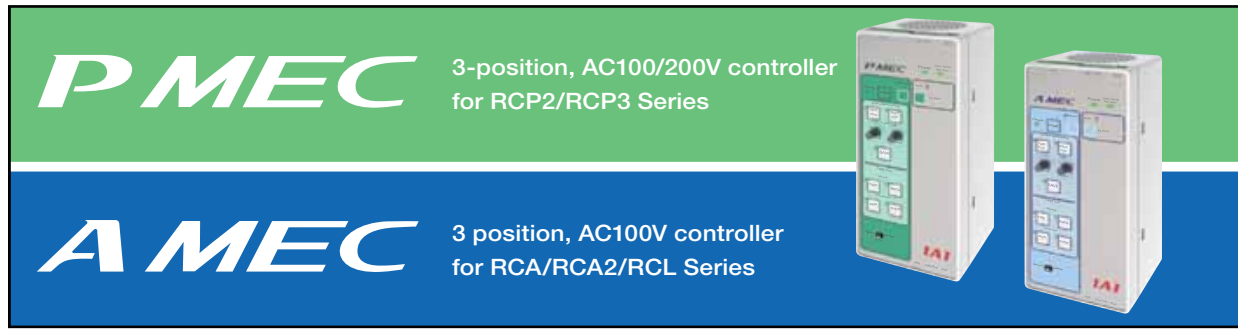

ROBO Cylinder 3-position controller **MEC** (Mechanical Engineer Control)

Feature

1 Low Cost

The PMEC package, which comes with a controller, power supply, acceleration/speed change function and PC connection cable, among others, is at an affordable price. The MEC PC software can be downloaded free of charge from IAI's website.

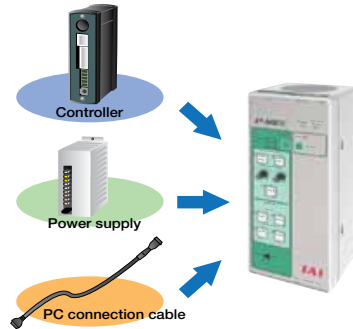

2 Easy Operation

Even a beginner can set up the controller without reading the operation manual. The acceleration and speed can be changed using the knobs on the controller.

* Setting range for acceleration/speed varies depending on the actuator. Please refer to the instruction manual for further detail.

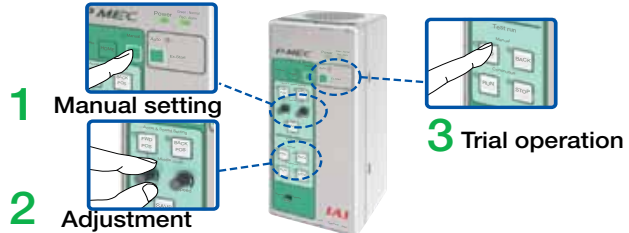

3 Easy Replacement from your Air-cylinder System

Operation signals are exactly the same as those used to operate air cylinders. This means that you can use the program of your current PLC directly.

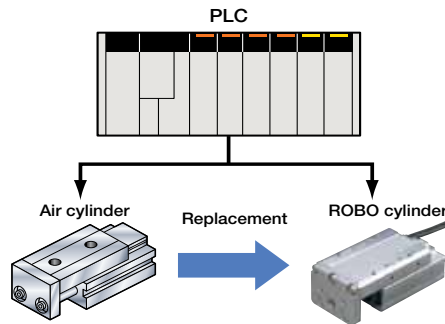

4 Push-motion Operation/Intermediate Stopping

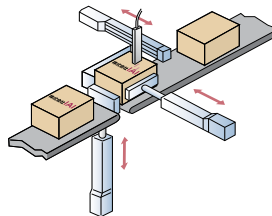

Push-motion operation can be performed in the same manner as you would with any air-cylinder system. Also, you can cause the actuator to stop at any desired intermediate point between the home position and stroke end by changing the setting of the intermediate point using the MEC PC software.



477 PMEC / AMEC

- Slider Type
- Mini
- Standard
- Controllers Integrated
- Rod Type
- Mini
- Standard
- Controllers Integrated
- Table/Arm /Flat Type
- Mini
- Standard
- Gripper/ Rotary Type
- Linear Servo Type
- Cleanroom Type
- Splash-Proof
- Controllers
- PMEC /AMEC
- PSEP /ASEP
- ROBO NET
- ERC2
- PCON
- ACON
- SCON
- PSEL
- ASEL
- SSEL
- XSEL
- Pulse Motor
- Servo Motor (24V)
- Servo Motor (200V)
- Linear Servo Motor

Model List

Series	PMEC	AMEC
External View		
Applicable actuators	RCP2 / RCP3	
Power supply voltage	100V	100-240V
Price	-	-
Accessories	AC power supply cable (2m) USB cable (3m) I/O cable (2m) I/O connector EMG connector Standard mounting bracket	

Model

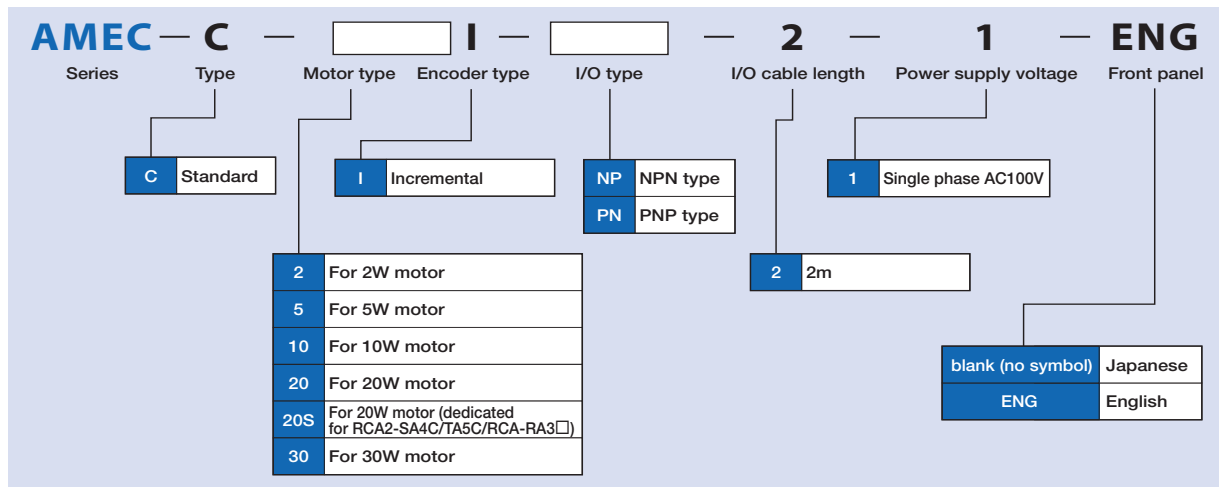
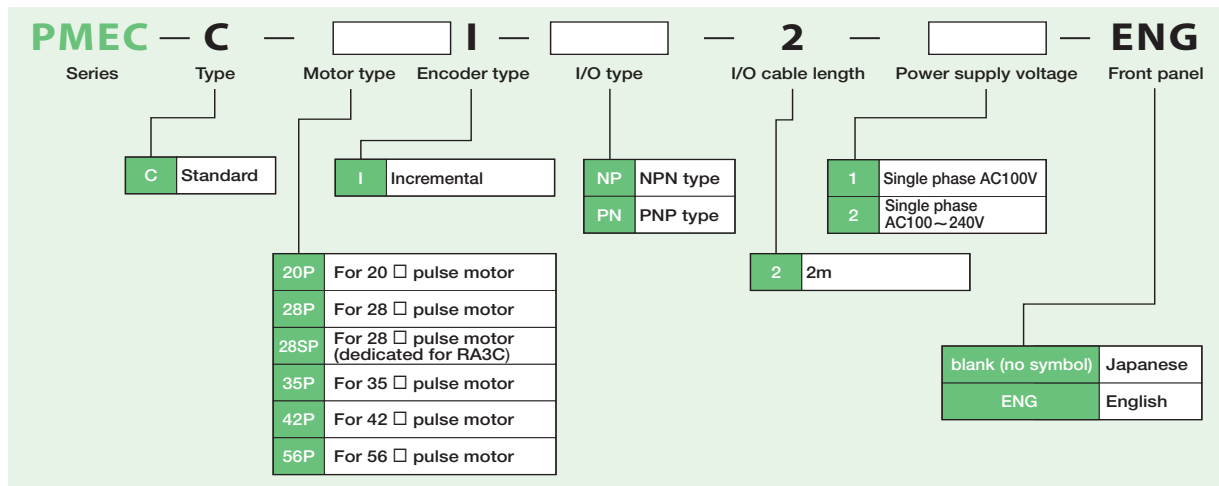

System Configuration

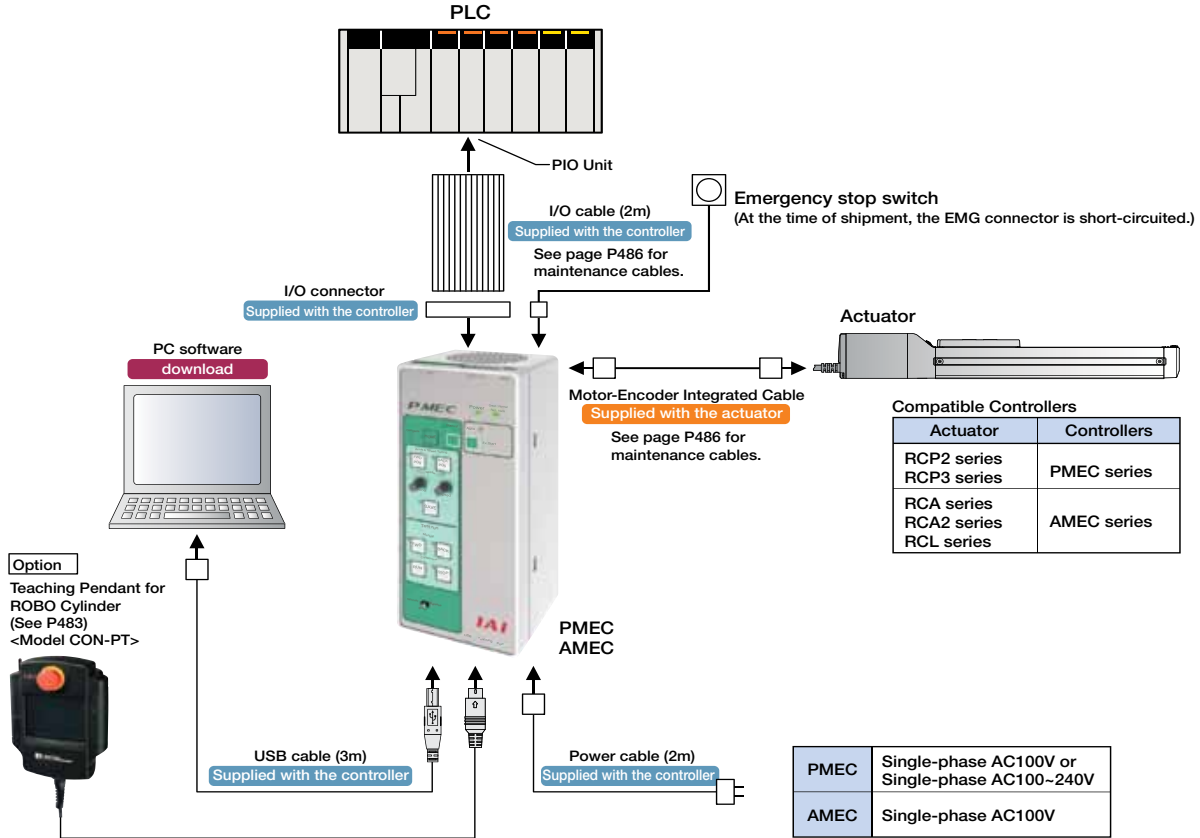

I/O Signal Table

Motion Pattern			2-Position Travel	3-Position Travel
Pin No.	Wire Color	Signal Type	Signal Name	Signal Name
1	Brown	PIO power	24V	24V
2	Red		0V	0V
3	Orange	Input	ST0 (Solenoid A: ON moves to end position, OFF moves to home position)	ST0 (Solenoid A: Move signal 1)
4	Yellow		—	ST1 (Solenoid B: Move signal 2)
5	Green		RES (Alarm reset)	RES (Alarm reset)
6	Blue		—	—
7	Purple	Output	LS0 (home position detection)/PE0 (home positioning complete)*1	LS0 (home position detection)/PE0 (home positioning complete)*1
8	Gray		LS1 (end position detection)/PE1 (end positioning complete)*1	LS1 (end position detection)/PE1 (end positioning complete)*1
9	White		HEND (Homing complete)	LS2 (intermediate point detection)/PE2 (intermediate positioning complete)*1
10	Black		* ALM (alarm)*2	* ALM (alarm)*2

*1: Signals PE0 through PE2 will be output if the pushing motion was enabled in the initial setting. Otherwise, LS0 through LS2 will be output.
*2: * ALM is ON when normal, and OFF when it is activated.

MEC PC software

By using the MEC PC software you can change the stop position data or run a test operation. In addition, you can change the setting on the intermediate stop function, pushing function or change the coordinates.

479 PMEC / AMEC

Explanation of PIO Patterns

PIO Pattern (2-position travel)

This motion pattern is between two positions, the home position and the end position. The home and end position can be configured numerically (using the MEC PC software or the optional touch panel teaching pendant). Two motions are possible: A positioning motion moves the rod or the slider to the specified position, and a pushing motion presses the rod against a workpiece.

Positioning

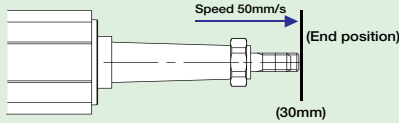

Input Signal

ST0	Solenoid A	ON
-----	------------	----

When ST0 is turned ON, the slider/rod moves at 50mm/s to the end position (30mm position).

End Position Data

Position	30mm
Speed	50mm/s
Pushing Force	—
Width	—

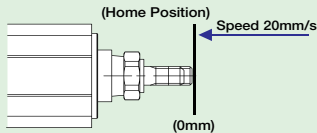

Input Signal

ST0	Solenoid A	OFF
-----	------------	-----

When ST0 is turned OFF, the slider/rod returns to the home position (0mm position) at 20mm/s.

Home Position Data

Position	0mm
Speed	20mm/s
Pushing Force	—
Width	—

PIO Pattern (2-position travel)

This motion pattern is between two positions, the home position and the end position, which enables a pushing motion of the rod against a workpiece.

Push

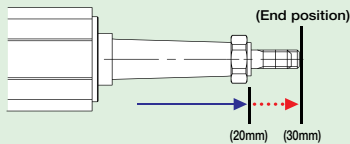

Input Signal

ST0	Solenoid A	ON
-----	------------	----

When the input 0 is turned ON, the actuator moves the rod to the 20mm position at 80mm/s, and from there, pushes it at slower speed to the 30mm position.

End Position Data

Position	30mm
Speed	80mm/s
Pushing Force	50%
Width	10mm

* The pushing motion is performed when there is a numerical value in the controller's push force data. (If there is no numerical value, a positioning motion is performed instead.)

PIO Pattern (3-position travel)

This motion pattern enables moves between three positions: the end position and the home position, as well as an intermediate position.

The positions are switched by combining two signals, ST0 and ST1.

Positioning

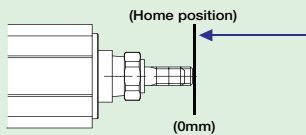

Input Signal

ST0	Solenoid A	ON
ST1	Solenoid B	OFF

When only the ST0 is turned ON, the actuator moves to the starting position at a set acceleration and speed.

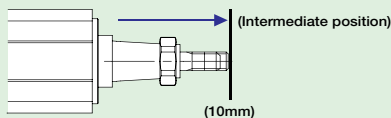

Input Signal

ST0	Solenoid A	ON*
ST1	Solenoid B	ON*

When both ST0 and ST1 are turned ON, it will move to the intermediate position at the set acceleration and speed. When both are turned OFF, it stops at the current position.

* By default, you can configure the MEC where you turn both signals OFF to move to the intermediate position, or both ON to stop at the current position.

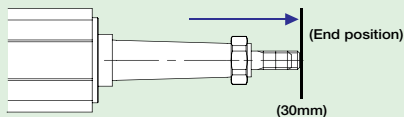

Input Signal

ST0	Solenoid A	OFF
ST1	Solenoid B	ON

When only ST1 is turned ON, the actuator moves to the end position at a set acceleration and speed.

- Slider Type
- Mini
- Standard
- Controllers Integrated
- Rod Type
- Mini
- Standard
- Controllers Integrated
- Table/Arm /Flat Type
- Mini
- Standard
- Gripper/ Rotary Type
- Linear Servo Type
- Cleanroom Type
- Splash-Proof
- Controllers
- PMEC /AMEC
- PSEP /ASEP
- ROBO NET
- ERC2
- PCON
- ACON
- SCON
- PSEL
- ASEL
- SSEL
- XSEL
- Pulse Motor
- Servo Motor (24V)
- Servo Motor (200V)
- Linear Servo Motor

- Slider Type
- Mini
- Standard
- Controllers Integrated
- Rod Type
- Mini
- Standard
- Controllers Integrated
- Table/Arm /Flat Type
- Mini
- Standard
- Gripper/ Rotary Type
- Linear Servo Type
- Cleanroom Type
- Splash-Proof
- Controllers
- PMEC /AMEC
- PSEP /ASEP
- ROBO NET
- ERC2
- PCON
- ACON
- SCON
- PSEL
- ASEL
- SSEL
- XSEL
- Pulse Motor
- Servo Motor (24V)
- Servo Motor (200V)
- Linear Servo Motor

Specifications Table

Item	Type		
Controller Type	PMEC		AMEC
Connectible Actuators	RCP2/RCP3 Series Actuators		RCA/RCA2/RCL Series Actuators
Number of Controllable Axes	Single axis		
Operation Method	Positioner Type		
Number of Positions	2 positions / 3 positions		
Backup Memory	EEPROM		
I/O Connector	10-pin terminal block		
I/O Points	4 input points / 4 output points		
Power for I/O	Externally supplied DC24V±10%		
Serial Communication	RS485: 1ch/USB: 1ch		
Position Detection Method	Incremental encoder		
Power Supply Voltage	AC100V-115V±10%	AC90V-264V	AC100V-115V±10%
Rated Current	1.3A	0.67A (AC100V)/0.36A (AC200V)	2.4A
Rush Current	30A	15A (AC100V)/30A (AC200V)	15A
Leak Current	0.50mA max	0.40mA max (AC100V) 0.75mA max (AC200V)	0.50mA max
Dielectric Strength Voltage	DC500V 1MΩ		
Vibration Resistance	XYZ directions 10-57Hz One-side amplitude 0.035mm (continuous), 0.075mm (intermittent) 57-150Hz 4.9m/s ² (continuous), 9.8m/s ² (intermittent)		
Ambient Operating Temperature	0-40°C		
Ambient Operating Humidity	10-85% RH (non-condensing)		
Ambient Operating Atmosphere	Free from corrosive gases		
Protection Class	IP20		
Weight	500g	508g	614g

Note: The minimum/maximum speeds vary depending on the actuator model. For more information, see the instruction manual, or contact IAI.

Outer Dimensions

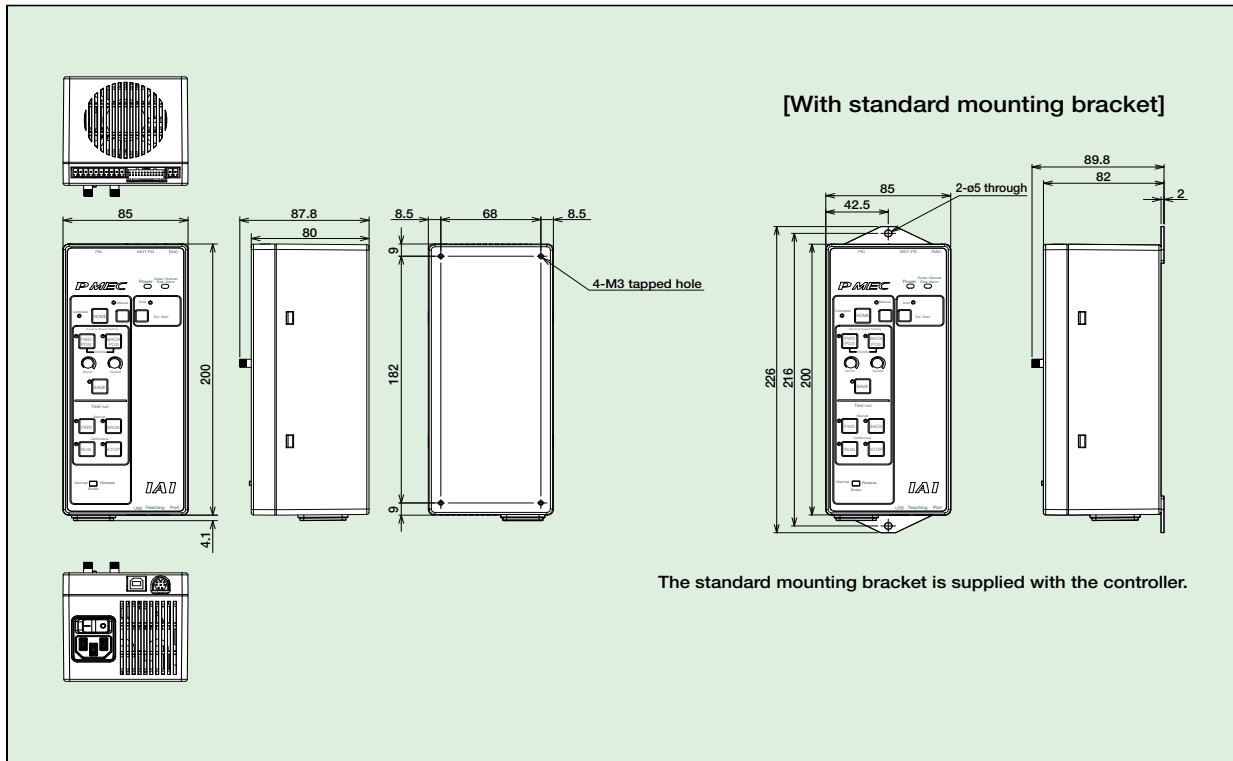

481 PMEC / AMEC

Names of Parts and Functions

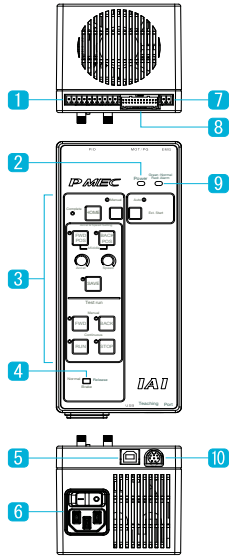

- 1 PIO connector Connects with a PLC or other external controllers to communicate inputs and outputs (I/O).
- 2 Power LED When the power is ON, it illuminates in green.
- 3 Control panel See below
- 4 Brake switch

Release	Used to release the brake of the actuator
Normal	The controller automatically controls the brake of the actuator
- 5 USB connector When using MEC PC software, connect to the computer via USB.
- 6 AC inlet Insert the power supply cable.
- 7 EMG connector Connect the emergency stop button. Short-circuit it if you will not be using an emergency stop button.
- 8 M/PG connector Insert the motor / encoder cable that connects with the actuator.
- 9 Status LED

RUN (Green)	Indicates the servo status. On = Servo ON, Off=Servo OFF (Energy-saving) status Flashing (1Hz)=Auto servo OFF
ALM (Red)	The LED illuminates if an alarm is turned ON or if the controller has come to an emergency stop.
EMG (Red)	
- 10 SIO Connector Connects with the teaching pendant (CON-PT, SEP-PT).

Explanation of the Control Panel

HOME button

When starting, homing is performed first to confirm the 0mm coordinate.

Manual button

Press this button to set the acceleration and/or speed, or to run a test operation. (Press for at least 1 second)

AUTO button

Press this button when operating from the MEC PC software or the PLC commands. (Press for at least 1 second)

Acceleration/Speed Settings
Configure the actuator's motion.

FWD POS / BACK POS button

Switch the motion you want to configure (see types below).

FWD POS: Motion toward the end position
BACK POS: Motion toward the home position
Middle: Motion toward an intermediate position
(Enabled from the MEC PC software. simultaneously press "FWD POS" and "BACK POS" to switch. During a 2-position stop, simultaneous pressing is disabled.)

Acceleration / Speed knob

By turning the knob, you can change the speed between 1%~100% of the actuator's maximum speed or rated acceleration / deceleration.
* The minimum speed may be less than 1% in some cases.

SAVE button

Saves the speed and acceleration adjusted above.

Test Operation
Confirm the saved motion by physically running the actuator.

FWD button

In a 2-position travel, the actuator moves from the BACK position to the FWD position. In a 3-position travel, the actuator moves from the BACK position to the intermediate position, then to the FWD position.

BACK button

The actuator returns to the starting position.

RUN button

In a 2-position travel, the actuator moves back and forth between the FWD and BACK positions. In a 3-position travel, the actuator repeats its movement from the BACK position, intermediate position, FWD position, then BACK position.

STOP button

Stops the above operation.

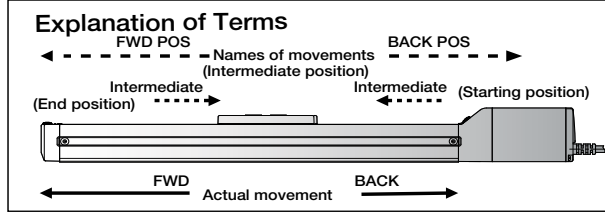

- Slider Type
- Mini
- Standard
- Controllers Integrated
- Rod Type
- Mini
- Standard
- Controllers Integrated
- Table/Arm /Flat Type
- Mini
- Standard
- Gripper/ Rotary Type
- Linear Servo Type
- Cleanroom Type
- Splash-Proof
- Controllers
- PMEC /AMEC
- PSEP /ASEP
- ROBO NET
- ERC2
- PCON
- ACON
- SCON
- PSEL
- ASEL
- SSEL
- XSEL
- Pulse Motor
- Servo Motor (24V)
- Servo Motor (200V)
- Linear Servo Motor

- Slider Type
- Mini
- Standard
- Controllers Integrated
- Rod Type
- Mini
- Standard
- Controllers Integrated
- Table/Arm /Flat Type
- Mini
- Standard
- Gripper/ Rotary Type
- Linear Servo Type
- Cleanroom Type
- Splash-Proof
- Controllers
- PMEC /AMEC
- PSEP /ASEP
- ROBO NET
- ERC2
- PCON
- ACON
- SCON
- PSEL
- ASEL
- SSEL
- XSEL
- Pulse Motor
- Servo Motor (24V)
- Servo Motor (200V)
- Linear Servo Motor

Option

● Teaching pendant for position controller

Features Data input device easy-to-operate even for beginners with a simple interactive menu screen. Operation arrangements such as positioning of home, end or intermediate position, setting of speed or push force and movement to jog/inching/order position are available.

■ Model/specifications

Item	Description	
Model	Japanese edition	CON-PT-M
	English edition	CON-PT-M-ENG
Type	Standard	
Function	Input/edit position data Movement functions (move to a specified position, jog, inch) Test input and output signals Edit parameters Switch language (Japanese/English)	
Label	3-color LED with backlight	
Ambient operating temp./humidity	0 ~ 50°C 20 ~ 85%RH (no condensation)	
Environmental resistance	IP40	
Weight (including cable)	750g	
Accessories	Touch pen	
Standard price	-	



■ Part names / dimensions

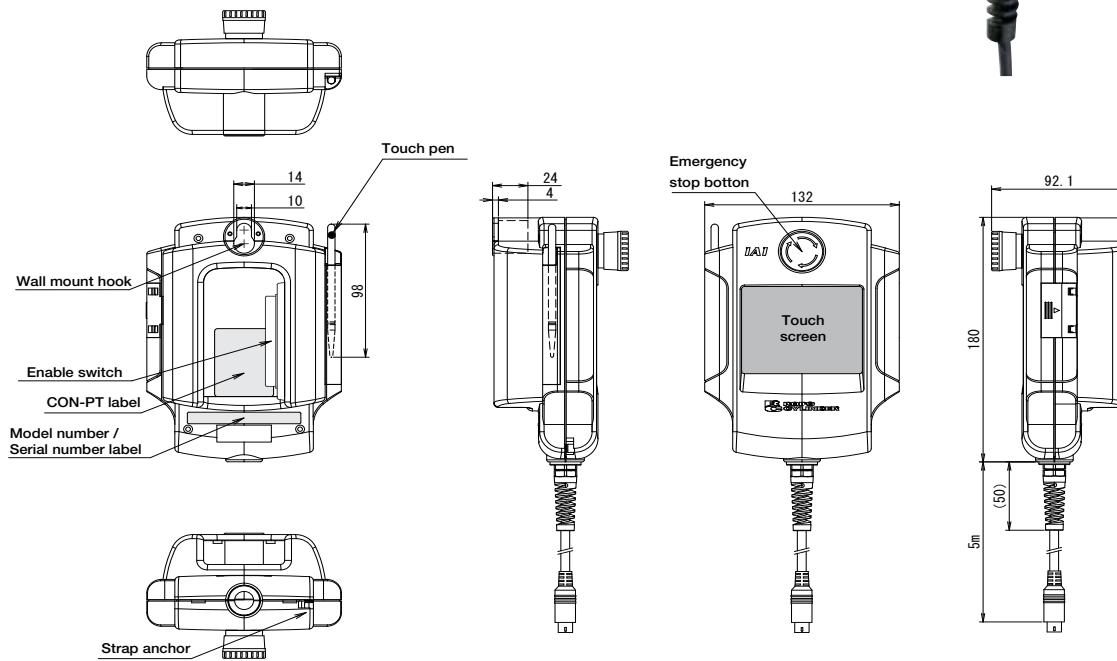

■ Option

- Strap model STR-1



483 PME / AMEC

● **DIN Rail Mounting Bracket MEC-AT-D**

■ **Dimensions**

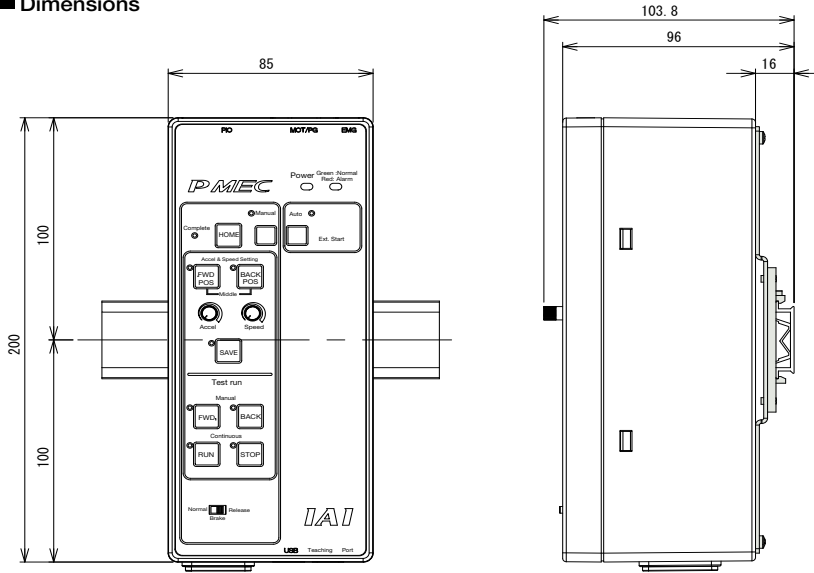

● **Maintenance cable**

■ **List of maintenance cable models**

Type		Cable length	Model	Standard price
Integrated motor-encoder cable	PMEC ↔ RCP3 RCP2-GRSS/GRLS/ GRST/ SRA4R/SRGS4R/ SRGD4R	1m	CB-APSEP-MPA010	-
		3m	CB-APSEP-MPA030	-
		5m	CB-APSEP-MPA050	-
	PMEC ↔ RCP2	1m	CB-PSEP-MPA010	-
		3m	CB-PSEP-MPA030	-
		5m	CB-PSEP-MPA050	-
	PMEC ↔ RCP2-RTBS/RTBSL -RTCS/RTCSL	1m	CB-RPSEP-MPA010	-
		3m	CB-RPSEP-MPA030	-
		5m	CB-RPSEP-MPA050	-
	AMEC ↔ RCA	1m	CB-ASEP-MPA010	-
		3m	CB-ASEP-MPA030	-
		5m	CB-ASEP-MPA050	-
I/O cable	2m	CB-APMEC-PIO020-NC	-	
	3m	CB-APMEC-PIO030-NC	-	
	5m	CB-APMEC-PIO050-NC	-	
USB cable	3m	CB-SEL-USB030	-	

- Slider Type
- Mini
- Standard
- Controllers Integrated
- Rod Type
- Mini
- Standard
- Controllers Integrated
- Table/Arm /Flat Type
- Mini
- Standard
- Gripper/ Rotary Type
- Linear Servo Type
- Cleanroom Type
- Splash-Proof
- Controllers
- PMEC /AMEC
- PSEP /ASEP
- ROBO NET
- ERC2
- PCON
- ACON
- SCON
- PSEL
- ASEL
- SSEL
- XSEL
- Pulse Motor
- Servo Motor (24V)
- Servo Motor (200V)
- Linear Servo Motor

Components for maintenance

Please refer to the models mentioned below when arrangements such as cable replacement are needed after purchasing the product.

[RCP3/RCP2 (for specific models*) /RCA2/RCL]-[PMEC/AMEC] Motor encoder integrated cable for indirect connection

Model **CB-APSEP-MPA**

* Enter cable length (L) required in (compatible for up to max. 20m).
Example: 080=8m

* For RCP2-GRSS/GRLS/GRST/SRA4R/SRGS4R/SRGD4R

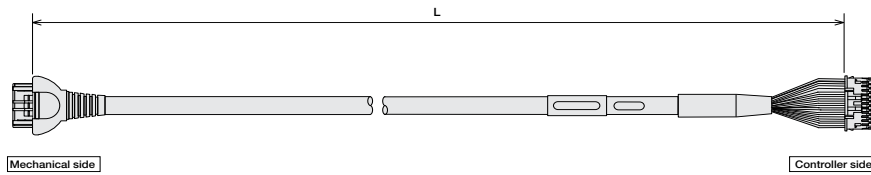

Mechanical side Pin number		Controller side Pin number
A1	Black [0A] (U)	1
B1	White [VMM] (V)	2
A2	Brown [0/A] (W)	5
B2	Green [0B] (-)	3
A3	Yellow [VMM] (-)	4
B3	Red [0/B] (-)	6
A4	Orange [LS+](BK+)	7
B4	Gray [LS-](BK-)	8
A6	White [-] (A+)	11
B6	Yellow [-] (A-)	12
A7	Red [A+] (B+)	13
B7	Green [A-] (B-)	14
A8	Black [B+] (Z+)	15
B8	Brown [B-] (Z-)	16
A5	Black (label) [BK+] (LS+)	9
B5	Brown (label) [BK-] (LS-)	10
A9	Green (label) [GNDLS] (GNDLS)	20
B9	Red (label) [VPS] (VPS)	18
A10	White (label) [VCC] (VCC)	17
B10	Yellow (label) [GND] (GND)	19
A11	NC	21
B11	Shield [FG] (FG)	24
	NC	22
	NC	23

Min. bend radius r=68mm or larger (when movable unit is used)

[RCP2]-[PMEC] Integrated motor-encoder connection cable

Model **CB-PSEP-MPA**

* Enter cable length (L) required in (compatible for up to max. 20m).
Example: 080=8m

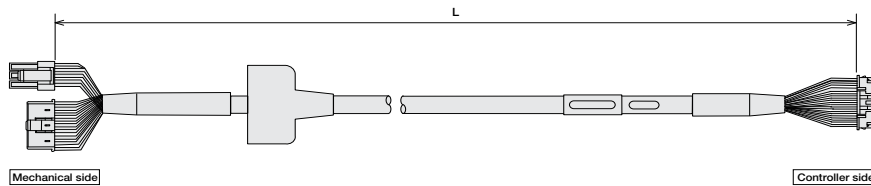

Mechanical side Pin number		Controller side Pin number
1	Black [0A]	1
2	White [VMM]	2
4	Red [0B]	3
5	Green [VMM]	4
3	Brown [0/A]	5
6	Yellow [0/B]	6
16	Orange [BK+]	9
17	Gray [BK-]	10
5	NC	11
6	NC	12
13	Black [LS+]	7
14	Brown [LS-]	8
1	White [A+]	13
2	Yellow [A-]	14
3	Red [B+]	15
4	Green [B-]	16
10	White (label) [VCC]	17
11	Yellow (label) [VPS]	18
9	Red (label) [GND]	19
12	Green (label) [Spare]	20
15	NC	21
7	NC	22
8	NC	23
18	Shield [FG]	24

Min. bend radius r=68mm or larger (when movable unit is used)

[RCA]-[AMEC] Integrated motor-encoder connection cable

Model **CB-ASEP-MPA**

* Enter cable length (L) required in (compatible for up to max. 20m).
Example: 080=8m

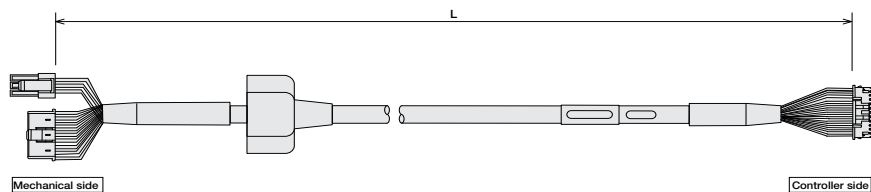

Mechanical side Pin number		Controller side Pin number
1	Red [U]	1
2	Yellow [V]	2
	NC	3
	NC	4
3	Black [W]	5
	NC	6
18	Orange [BK+]	7
17	Gray [BK-]	8
7	Black [LS+]	9
16	Brown [LS-]	10
1	White [A+]	11
2	Yellow [A-]	12
3	Red [B+]	13
4	Green [B-]	14
10	Black (label) [Z+]	15
11	Brown (label) [Z-]	16
14	White (label) [VCC]	17
13	Yellow (label) [VPS]	18
15	Red (label) [GND]	19
6	Green (label) [Spare]	20
5	NC	21
8	NC	22
12	NC	23
9	Shield [FG]	24

Min. bend radius r=68mm or larger (when movable unit is used)

485

PMEC / AMEC

[RCP2 small rotary]-[PMEC] Motor encoder integrated cable for indirect connection

Model **CB-RPSEP-MPA**

*Enter cable length (L) required in (compatible for up to max. 20m).
Example: 080=8m

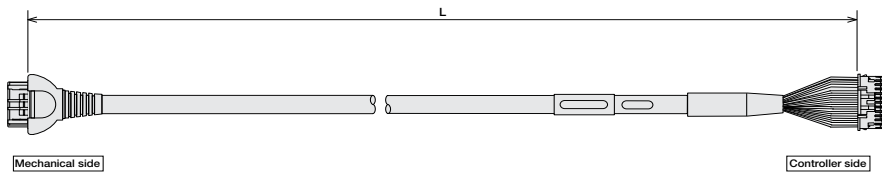

Min. bend radius r=68mm or larger (when movable unit is used)

Mechanical side Pin number	Color / Label	Controller side Pin number
A1	Black [OA]	1
B1	White [VMM]	2
A2	Brown [O/A]	5
B2	Green [O/B]	3
A3	Yellow [VMM]	4
B3	Red [O/B]	6
A6	Orange [LS+]	7
B6	Gray [LS-]	8
A7	Red [A+]	13
B7	Green [A-]	14
A8	Black [B+]	15
B8	Brown [B-]	16
A4	NC	7
B4	NC	8
A5	Black (label)[BK+]	9
B5	Brown (label)[BK-]	10
A9	Green (label)[GNDLS]	20
B9	Red (label)[VPS]	18
A10	White (label)[VCC]	19
B10	Yellow (label)[GND]	17
A11	NC	21
B11	Shield FG	24
	NC	22
	NC	23

I/O cable for PMEC-C/AMEC-C

Model **CB-APMEC-PIO** -NC

*The 3 types differ in cable length: 020=2m, 030=3m, 050=5m

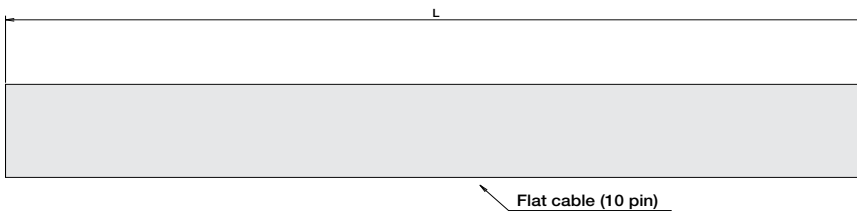

Flat cable (10 pin)

Pin NO.	Electric wire color	Signal
1	Brown	PIO Power supply
2	Red	
3	Orange	Input
4	Yellow	
5	Green	
6	Blue	
7	Purple	Output
8	Grey	
9	White	
10	Black	

- Slider Type
- Mini
- Standard
- Controllers Integrated
- Rod Type
- Mini
- Standard
- Controllers Integrated
- Table/Arm /Flat Type
- Mini
- Standard
- Gripper/ Rotary Type
- Linear Servo Type
- Cleanroom Type
- Splash-Proof
- Controllers
- PMEC /AMEC
- PSEP /ASEP
- ROBO NET
- ERC2
- PCON
- ACON
- SCON
- PSEL
- ASEL
- SSEL
- XSEL
- Pulse Motor
- Servo Motor (24V)
- Servo Motor (200V)
- Linear Servo Motor

- Slider Type
- Mini
- Standard
- Controllers Integrated
- Rod Type
- Mini
- Standard
- Controllers Integrated
- Table/Arm /Flat Type
- Mini
- Standard
- Gripper/ Rotary Type
- Linear Servo Type
- Cleanroom Type
- Splash-Proof
- Controllers
- PMEC /AMEC
- PSEP /ASEP
- ROBO NET
- ERC2
- PCON
- ACON
- SCON
- PSEL
- ASEL
- SSEL
- XSEL
- Pulse Motor
- Servo Motor (24V)
- Servo Motor (200V)
- Linear Servo Motor

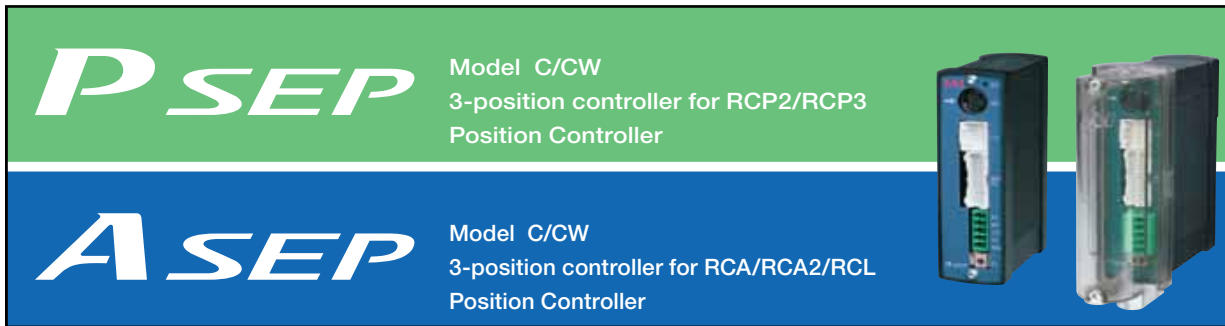

Feature

1 Can operate with same signal as a solenoid valve.

The signal that operates the actuator is the same as the signal that operates the air cylinder. Therefore, the PLC program currently in use can be used without modification even if the air cylinder is replaced by an electric-powered cylinder. Either a single solenoid or a double solenoid may be used.

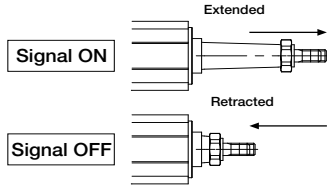

2 Establishes a dustproof type that supports IP53.

We provide dustproof type controllers with an IP53 equivalent (*1) protection structure, so that the controller can be mounted outside the control panel.

(1) Bottom surface excluded.



3 Provides the simple absolute type that can be operated immediately upon power-ON without homing.

Since the simple absolute type can store the current position with the assistance of the absolute battery unit during power-up or after the emergency stop is deactivated; it can start the next operation at that position.

(Note 1) When the actuator is connected to the simple absolute type controller, the model is considered an incremental model.
 (Note 2) It can not be used for the linear servo type.

When mounting the absolute battery unit, mount it below the SEP controller.

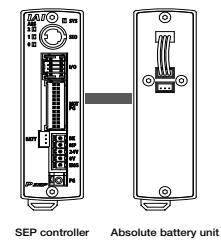

4 Pushing and intermediate stop operation is available.

Like air cylinders, the pushing operation is available. In this operation, you can stop with a rod being pushed to a workpiece. Since the force for the push operation is adjustable within a range between 20 to 70 % of the maximum pushing force and a signal is generated when it reaches the specified pushing force, it can be used to determine clamping or size of workpieces.

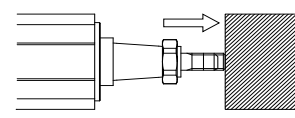





Push force is adjustable within the range of 20 to 70% of the maximum pushing force

5 Easy data entry with the dedicated touch panel teaching unit.

Data, such as setting target positions or pushing force, are easily entered with the optional touch panel teaching model: CON-PT. Since the touch panel teaching unit provides an interactive menu and can be controlled directly on the screen, you can operate intuitively with no assistance from operation manuals.



Model List

Series name	PSEP				ASEP			
	C		CW		C		CW	
Type	Standard		Dustproof		Standard		Dust proof	
Name	Standard		Dustproof		Standard		Dust proof	
Positioning method	Incremental encoder	Simple absolute type	Incremental encoder	Simple absolute type	Incremental encoder	Simple absolute type	Incremental encoder	Simple absolute type
External View								
Description	Position controller, for pulse motors, specialized to 2 positions / 3 positions positioning and easier control		PSEP-C dustproof type with an IP53 equivalent protection structure		Position controller, for servo motors, specialized to 2 positions / 3 positions positioning and easier control		ASEP-C dustproof type with an IP53 equivalent protection structure	
Number of positions	2 positions / 3 positions							
Standard price	-	-	-	-	-	-	-	-

Model

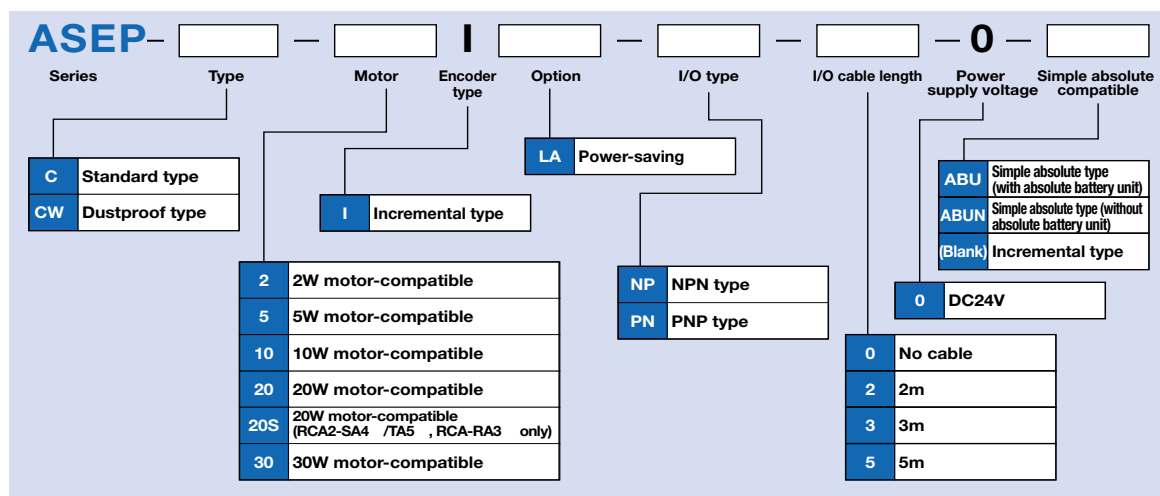
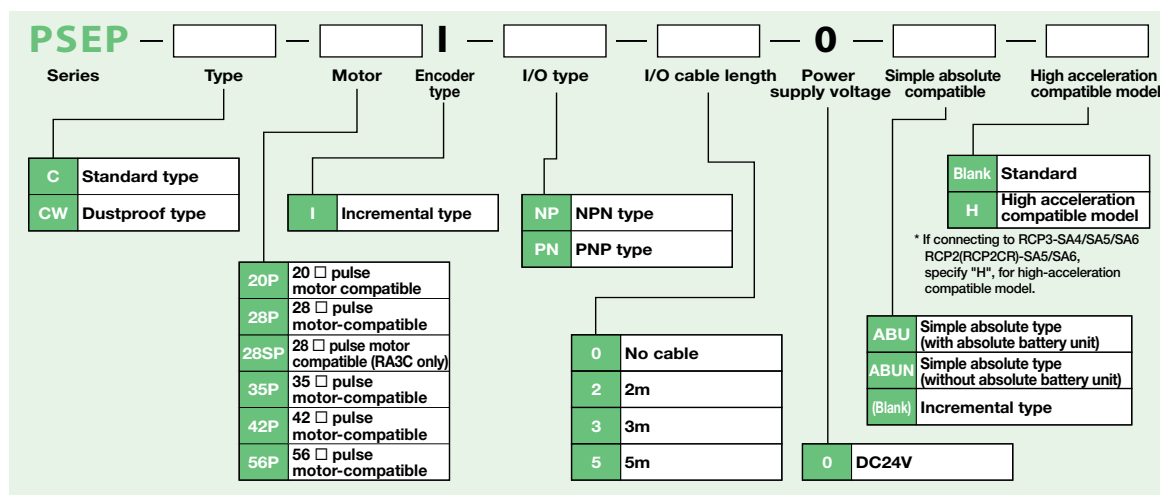

- Slider Type
- Mini
- Standard
- Controllers Integrated
- Rod Type
- Mini
- Standard
- Controllers Integrated
- Table/Arm /Flat Type
- Mini
- Standard
- Gripper/ Rotary Type
- Linear Servo Type
- Cleanroom Type
- Splash-Proof
- Controllers
- PMEC /AMEC
- PSEP /ASEP
- ROBO NET
- ERC2
- PCON
- ACON
- SCON
- PSEL
- ASEL
- SSEL
- XSEL
- Pulse Motor
- Servo Motor (24V)
- Servo Motor (200V)
- Linear Servo Motor

System structure

[PSEP]

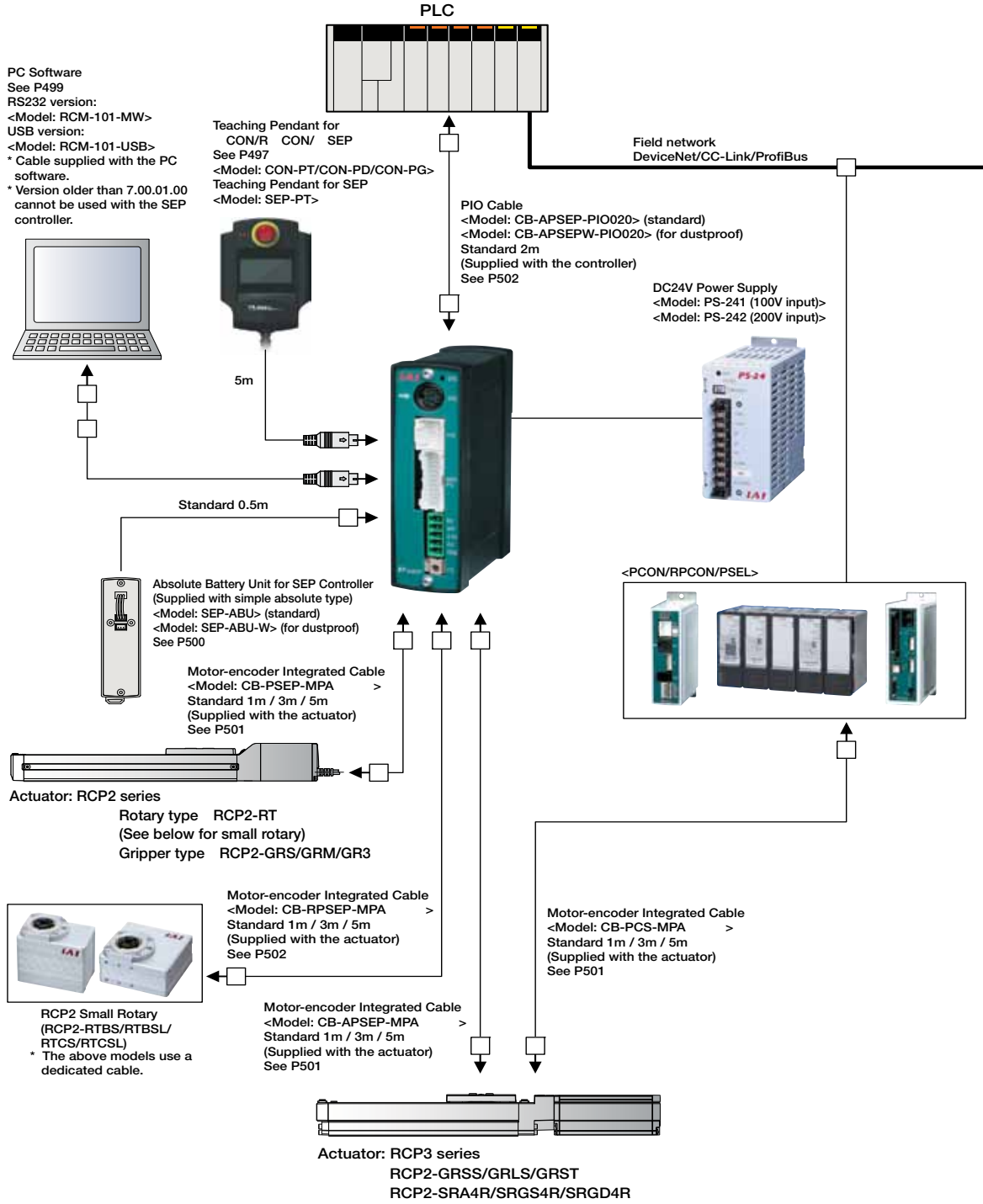

- Slider Type
- Mini
- Standard
- Controllers Integrated
- Rod Type
- Mini
- Standard
- Controllers Integrated
- Table/Arm /Flat Type
- Mini
- Standard
- Gripper/ Rotary Type
- Linear Servo Type
- Cleanroom Type
- Splash-Proof
- Controllers
- PMEC /AMEC
- PSEP /ASEP
- ROBO NET
- ERC2
- PCON
- ACON
- SCON
- PSEL
- ASEL
- SSEL
- XSEL
- Pulse Motor
- Servo Motor (24V)
- Servo Motor (200V)
- Linear Servo Motor

System structure

[ASEP]

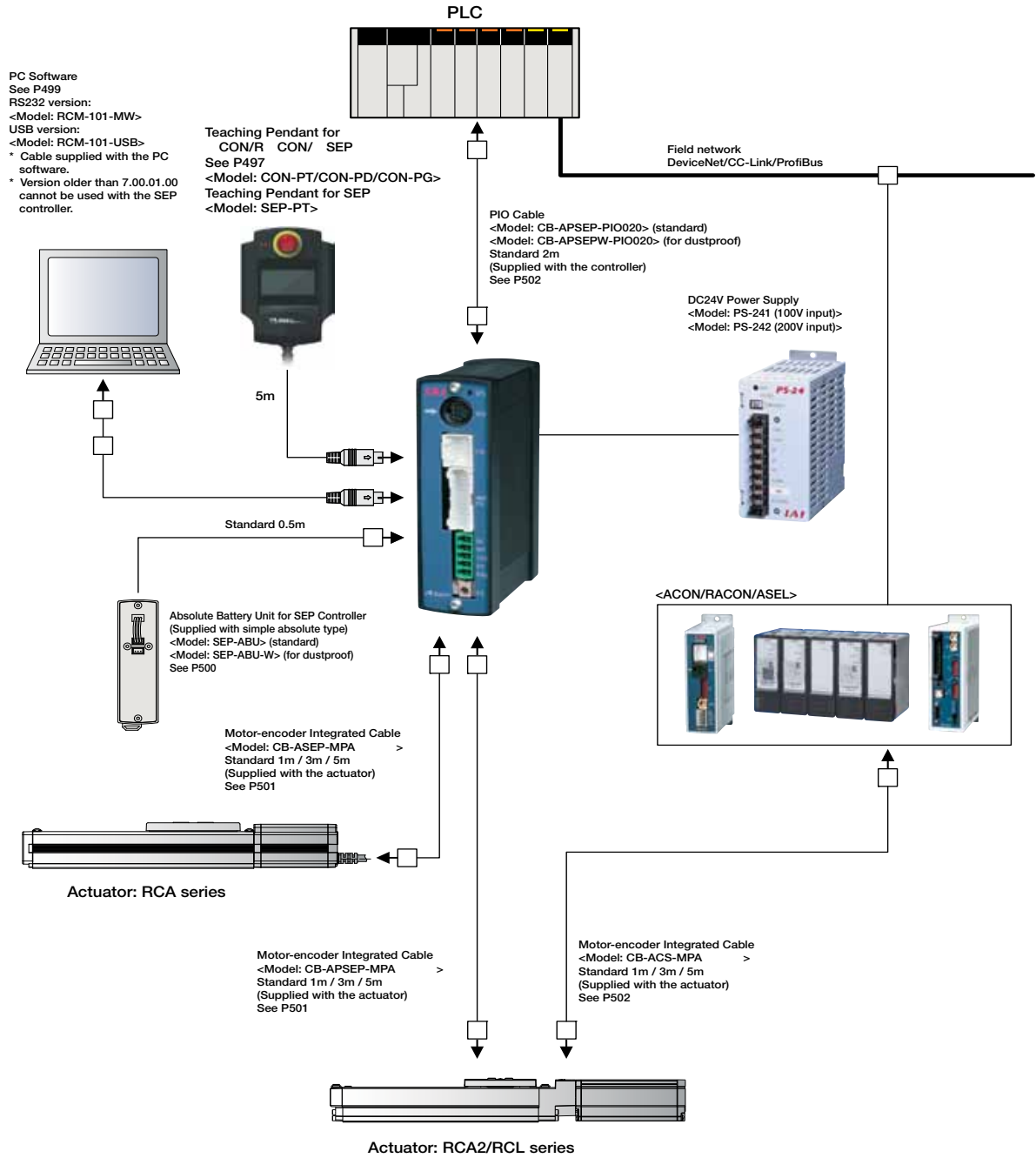

- Slider Type
- Mini
- Standard
- Controllers Integrated
- Rod Type
- Mini
- Standard
- Controllers Integrated
- Table/Arm /Flat Type
- Mini
- Standard
- Gripper/ Rotary Type
- Linear Servo Type
- Cleanroom Type
- Splash-Proof
- Controllers
- PMEC /AMEC
- PSEP /ASEP
- ROBO NET
- ERC2
- PCON
- ACON
- SCON
- PSEL
- ASEL
- SSEL
- XSEL
- Pulse Motor
- Servo Motor (24V)
- Servo Motor (200V)
- Linear Servo Motor

PIO Pattern Description

The SEP controller provides the following six PIO patterns from which you can choose for operation. Also, PIO patterns 0 to 2 support both the single solenoid and double solenoid signal configurations.

PIO Pattern Number		0		1		2		3		4		5	
PIO Pattern Name		Standard 2-position movement		Moving speed change		Position Data Change		2-input 3-position travel		3-input 3-position travel		Continuous cycle operation	
Feature		Continuous cycle operation		2-position motion		2-position motion		3-position motion		3-position motion		Continuous motion between 2 positions	
		Push		Push		Push		Push		Push		Push	
		-		Changing speed during motion		Motion position data change		-		-		-	
Supported solenoid configurations		Single	Double	Single	Double	Single	Double	-		-		-	
Input	0	Motion signal	Motion signal 1	Motion signal	Motion signal 1	Motion signal	Motion signal 1	Motion signal 1	Retract motion signal	Continuous operation signal			
	1	Pause signal	Motion signal 2	Pause signal	Motion signal 2	Pause signal	Motion signal 2	Motion signal 2	Extend motion signal	Pause signal			
	2	- (Reset signal)		Moving speed change signal (reset signal)		Target position change signal (reset signal)		- (Reset signal)		Intermediate motion signal (reset signal)		- (Reset signal)	
	3	-/Servo-ON signal		-/Servo-ON signal		-/Servo-ON signal		-/Servo-ON signal		-/Servo-ON signal		-/Servo-ON signal	
Output	0	Retract motion output signal		Retract motion output signal		Retract motion output signal		Retract motion output signal		Retract motion output signal		Retract motion output signal	
	1	Extend motion output signal		Extend motion output signal		Extend motion output signal		Extend motion output signal		Extend motion output signal		Extend motion output signal	
	2	Homing completion signal / Servo-ON output signal		Homing completion signal / Servo-ON output signal		Homing completion signal / Servo-ON output signal		Midpoint position output signal		Midpoint position output signal		Homing completion signal / Servo-ON output signal	
	3	Alarm output signal / Servo-ON output signal		Alarm output signal / Servo-ON output signal		Alarm output signal / Servo-ON output signal		Alarm output signal / Servo-ON output signal		Alarm output signal / Servo-ON output signal		Alarm output signal / Servo-ON output signal	

* For the signals above, see the controller manuals (downloadable from our website).

PIO Pattern 0 (Standard 2-Position travel)

This PIO pattern involves movements between two positions—the end position and the home position. The positions can be set numerically to any position (by inputting to the controller using the optional touch panel teaching pendant). Two motions are possible: A “positioning motion” moves the rod or the slider to the specified position, and a “pushing motion” pushes the rod against a workpiece.

Positioning Motion (Single Solenoid)

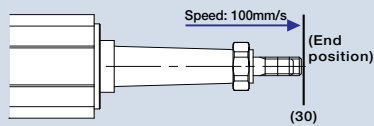

End Position Data	
Position	30
Speed	100
Pushing force	-
Width	-

Input Signals

Input 0	ON
Input 1	-
Input 2	-
Input 3	-

When Input 0 is turned ON, the slider/rod moves to the end position (30mm coordinate) at a speed of 100mm/s.

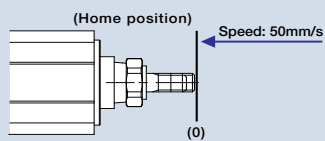

Home Position Data	
Position	0
Speed	50
Pushing force	-
Width	-

Input Signals

Input 0	OFF
Input 1	-
Input 2	-
Input 3	-

When input 0 is turned OFF, the slider/rod returns to the home position (0mm coordinate) at a speed of 50mm/s.

Positioning Motion (Double Solenoid)

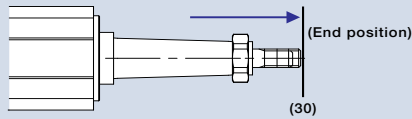

End Position Data	
Position	30
Speed	100
Pushing force	-
Width	-

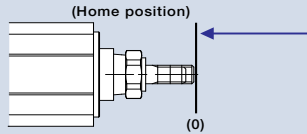

Home Position Data	
Position	0
Speed	50
Pushing force	-
Width	-

Input Signals

Input 0	OFF
Input 1	ON
Input 2	-
Input 3	-

When Input 1 is turned ON and Input 0 is turned OFF, the slider/rod moves to the end position (30mm coordinate) at a speed of 100mm/s.

Input Signals

Input 0	ON
Input 1	OFF
Input 2	-
Input 3	-

When Input 0 is turned ON and Input 1 is turned OFF, the slider/rod returns to the home position (0mm coordinate) at a speed of 50mm/s.

Push motion (single solenoid)

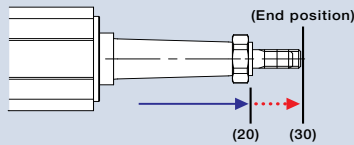

End Position Data	
Position	30
Speed	100
Pushing force	50
Width	10

Input Signals

Input 0	ON
Input 1	-
Input 2	-
Input 3	-

When Input 0 is turned ON, the rod moves to the 20mm position at 100mm/s, and then starts pushing from the 20mm position to the 30mm position at slow speed.

* The pushing motion is performed only if there is a numerical value for the pushing force in the controller's position data. (If there is no numerical value for the pushing force, a positioning motion will be performed instead.)

Push motion (double solenoid)

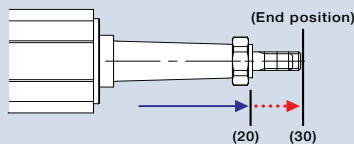

End Position Data	
Position	30
Speed	100
Pushing force	50
Width	10

Input Signals

Input 0	OFF
Input 1	ON
Input 2	-
Input 3	-

When Input 1 is turned ON and Input 0 is turned OFF, the rod moves to the 20mm position at 100mm/s, and then starts pushing from the 20mm position to the 30mm position at slow speed.

* The pushing motion is performed only if there is a numerical value for the pushing force in the controller's position data. (If there is no numerical value for the pushing force, a positioning motion will be performed instead.)

- Slider Type
- Mini
- Standard
- Controllers Integrated
- Rod Type
- Mini
- Standard
- Controllers Integrated
- Table/Arm /Flat Type
- Mini
- Standard
- Gripper/ Rotary Type
- Linear Servo Type
- Cleanroom Type
- Splash-Proof
- Controllers
- PMEC /AMEC
- PSEP /ASEP
- ROBO NET
- ERC2
- PCON
- ACON
- SCON
- PSEL
- ASEL
- SSEL
- XSEL
- Pulse Motor
- Servo Motor (24V)
- Servo Motor (200V)
- Linear Servo Motor

- Slider Type
- Mini
- Standard
- Controllers Integrated
- Rod Type
- Mini
- Standard
- Controllers Integrated
- Table/Arm /Flat Type
- Mini
- Standard
- Gripper/ Rotary Type
- Linear Servo Type
- Cleanroom Type
- Splash-Proof
- Controllers
- PMEC /AMEC
- PSEP /ASEP
- ROBO NET
- ERC2
- PCON
- ACON
- SCON
- PSEL
- ASEL
- SSEL
- XSEL
- Pulse Motor
- Servo Motor (24V)
- Servo Motor (200V)
- Linear Servo Motor

PIO Pattern 1 (Speed Change During Movement)

This PIO pattern involves movements between two positions—the end position and the home position. The speed can be changed in 2 stages. (The speed can be either increased or decreased.) The speed change occurs when the rod/slider passes the speed change position, specified in the position values.

(Single Solenoid)

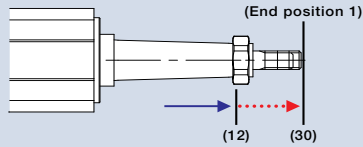
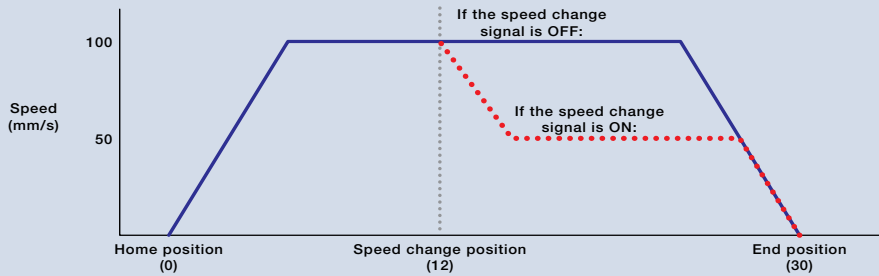

Input Signals

Input 0	ON
Input 1	-
Input 2	ON
Input 3	-

When Input 0 is turned ON while Input 2 is turned ON, the rod moves at the initial speed up to the trigger point. After it passes the trigger point, the speed changes. If Input 2 is not turned ON, the speed will not change.

Home Position Data	
Position	0
Speed	50
Trigger point	12
Trigger speed	100
Pushing force	-
Width	-

End Position Data	
Position	30
Speed	100
Trigger point	12
Trigger speed	50
Pushing force	-
Width	-

PIO Pattern 2 (Position Change)

This PIO pattern involves movements between two positions—the end position and the home position. You can set 2 sets of data for the end / home positions, speed, pushing force, and pushing width. Switching between the 2 sets of data can be done by turning ON/OFF Input 2, which is the signal for switching the target position.

(Single Solenoid)

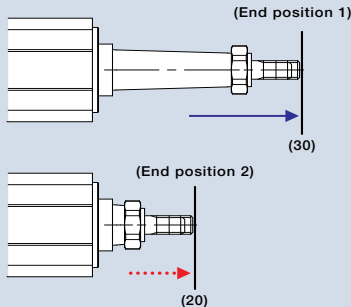
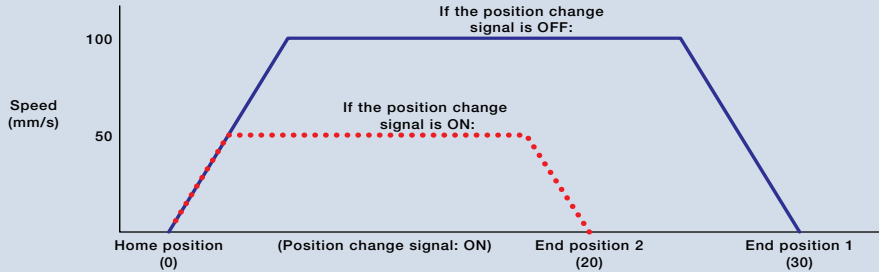

Input Signals

Input 0	ON
Input 1	-
Input 2	ON
Input 3	-

If Input 2 (position change signal) is OFF when Input 0 is turned ON, the rod moves according to the position and speed set in "End Position Data 1" (position: 30 / speed: 100).
 If Input 2 is ON when Input 0 is turned ON, the rod's movement changes to the position and speed set in "End Position Data 2" (position: 20 / speed: 50).
 If Input 2 is OFF when the movement starts, but is turned ON in transit, the target position and speed is changed from that position.

End Position Data 1	
Position	30
Speed	100
Pushing force	-
Width	-

End Position Data 2	
Position	20
Speed	50
Pushing force	-
Width	-

PIO Pattern 3 (2-Input 3-Position Travel)

This PIO pattern involves movements between 3 positions—the end position, the home position, and an intermediate position.

Changing between the positions is done by a combination of 2 signals, Input 0 and Input 1.

Positioning Motion

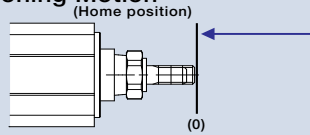

Input Signals

Input 0	ON
Input 1	OFF
Input 2	-
Input 3	-

When only Input 0 is turned ON, the rod moves to the home position at the specified speed.

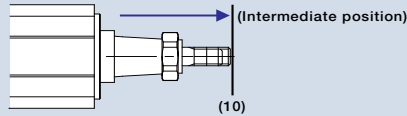

Input Signals

Input 0	ON
Input 1	ON
Input 2	-
Input 3	-

When Input 0 and Input 1 are both turned ON, the rod moves to the intermediate position at the specified speed.

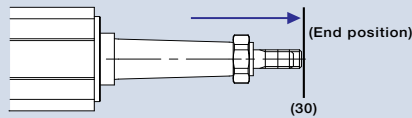

Input Signals

Input 0	OFF
Input 1	ON
Input 2	-
Input 3	-

When only Input 1 is turned ON, the rod moves to the end position at the specified speed.

PIO Pattern 4 (3-Input 3-Position Travel)

This PIO pattern involves movements between 3 positions—the end position, the home position, and an intermediate position.

Changing between positions is done by three signals—Input 0, Input 1 and Input 2, which are commanded to move to the home, end and intermediate positions, respectively.

Positioning Motion

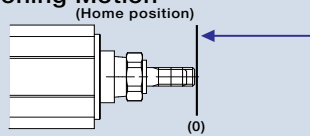

Input Signals

Input 0	ON
Input 1	OFF
Input 2	OFF
Input 3	-

When Input 0 is turned ON, the rod moves to the home position at the specified speed.

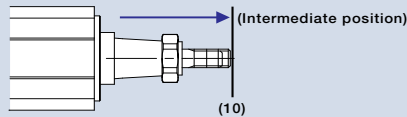

Input Signals

Input 0	OFF
Input 1	OFF
Input 2	ON
Input 3	-

When Input 2 is turned ON, the rod moves to the intermediate position at the specified speed.

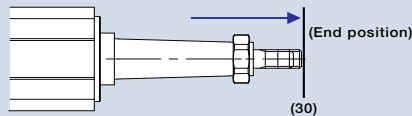

Input Signals

Input 0	OFF
Input 1	ON
Input 2	OFF
Input 3	-

When Input 1 is turned ON, the rod moves to the end position at the specified speed.

PIO Pattern 5 (Continuous Cycle Operation)

This PIO pattern involves continuous cycling between 2 positions—the end and home positions.

When Input 0 (continuous operation signal) is turned ON, the rod continuously moves between the specified 2 positions.

If Input 0 is turned OFF while in motion, it stops after reaching the current destination.

Positioning Motion

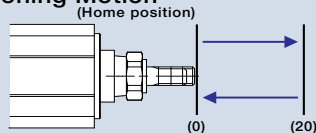

Input Signals

Input 0	ON
Input 1	-
Input 2	-
Input 3	-

When Input 0 is turned ON, the rod moves continuously between the end and home positions at the specified speed.

- Slider Type
- Mini
- Standard
- Controllers Integrated
- Rod Type
- Mini
- Standard
- Controllers Integrated
- Table/Arm /Flat Type
- Mini
- Standard
- Gripper/ Rotary Type
- Linear Servo Type
- Cleanroom Type
- Splash-Proof
- Controllers
- PMEC /AMEC
- PSEP /ASEP
- ROBO NET
- ERC2
- PCON
- ACON
- SCON
- PSEL
- ASEL
- SSEL
- XSEL
- Pulse Motor
- Servo Motor (24V)
- Servo Motor (200V)
- Linear Servo Motor

I/O Signal

Pin No.	Cable color	PIO pattern		0		1		2		3	4	5
		PIO pattern name		Standard 2-position motion		Speed change		Position change		2-input 3-position travel	3-input 3-position travel	Continuous cycle operation
		Solenoid type		Single	Double	Single	Double	Single	Double	-	-	-
1	Brown	COM		24V		24V		24V		24V	24V	24V
2	Red	COM		0V		0V		0V		0V	0V	0V
3	Orange	Input	0	ST0	ST0	ST0	ST0	ST0	ST0	ST0	ST0	ASTR
4	Yellow		1	*STP	ST1(-)	*STP	ST1(-)	*STP	ST1(-)	ST1	ST1(-)	-/*STP
5	Green		2	-(RES)	SPDC(RES)		CN1(RES)		-(RES)	ST2(RES)	-(RES)	-(RES)
6	Blue	Output	3	-/SON		-/SON		-/SON		-/SON	-/SON	-/SON
7	Purple		0	LS0/PE0		LS0/PE0		LS0/PE0		LS0/PE0	LS0/PE0	LS0/PE0
8	Grey		1	LS1/PE1		LS1/PE1		LS1/PE1		LS1/PE1	LS1/PE1	LS1/PE1
9	White		2	HEND/SV		HEND/SV		HEND/SV		LS2/PE2	LS2/PE2	HEND/SV
10	Black	3	*ALM/SV		*ALM/SV		*ALM/SV		*ALM/SV	*ALM/SV	*ALM/SV	

Note: The above signals marked with * are normally ON and turn OFF when active.

Specification Table

Item		Type					
Controller type		PSEP			ASEP		
		C	CW		C	CW	
Connected actuators		RCP2/RCP3 series actuator			RCA/RCA2/RCL series actuator		
Number of control axes		1					
Operating method		Positioner Type					
Number of positions		2 positions/3 positions (4 positions*2)					
Backup memory		EEPROM					
I/O connector		10 pin connector					
Number of I/O points		4 input points / 4 output points					
I/O power supply		External power supply DC24V±10%					
Dedicated type for serial communication		RS485 1ch					
Communication cable for peripheral equipment		CB-APSEP-PIO□□□□	CB-APSEP-W-PIO□□□□		CB-APSEP-PIO□□□□	CB-APSEP-W-PIO□□□□	
Position detection method		Incremental encoder (Attaching an absolute battery unit makes the simple absolute specification possible *3)					
Motor-encoder cable	For RCP2 connection	CB-PSEP-MPA□□□□			(Connection not possible)		
	For RCA connection	(Connection not possible)			CB-ASEP-MPA□□□□		
	For RCP3/RCA2 connection	CB-APSEP-MPA□□□□					
	For RCP2 mini rotary connection	CB-RPSEP-MPA□□□□			(Connection not possible)		
Input voltage		DC24V±10%					
Controlled power supply capacity		0.5A (0.8A for the simple absolute specification)					
Motor power capacity	Motor size	Rated value	Max.(*4)	Motor power output	Rated value	Maximum	
	20P	0.4A	2.0A	2W	0.8A	Power-saving (*5)	Standard (*6) high-acceleration / deceleration
	28P	0.4A	2.0A	5W	1.0A	Not specified	4.6A
	35P	1.2A	2.0A	10W (for RCL)	1.3A	Not specified	6.4A
	42P	1.2A	2.0A	10W (for RCA/RCA2)	1.3A	2.5A	4.4A
	56P	1.2A	2.0A	20W	1.3A	2.5A	4.4A
	-	-	-	20W (for 20S motor)	1.7A	3.4A	5.1A
-	-	-	30W	1.3A	2.2A	4.4A	
Inrush current (*1)		Max. 10A					
Amount of heat generated		8.4W			9.6W		
Dielectric strength voltage		DC500V 1MΩ					
Resistance to vibration		XYZ directions 10~57Hz One-side width 0.035mm (continuous), 0.075mm (intermittent) 58~150Hz 4.9m/s ² (continuous), 9.8m/s ² (intermittent)					
Ambient operating temperature		0~40°C					
Ambient operating humidity		10~85%RH (non-condensing)					
Ambient operating environment		No corrosive gases					
Protection level		IP20		IP53 (*7)		IP20	
Weight		About 130g		About 160g		About 130g	

(*1) Upon power-ON, an electrical current of 5 to 12 times as much as the rated current, called "in rush current" flows for 1 to 2 ms. Note that the amount of inrush current varies based on the impedance of power source lines.
 (*2) This applies to the case where two position data points are set at each of the end and home positions during a "position change" motion pattern process.
 (*3) The simple absolute type controllers cannot be used for the linear servo type.
 (*4) The current reaches its maximum level during the servo motor excitation phase detection performed during the initial servo ON process after the power has been turned on. (Usually: Approx. 1 to 2 seconds, max. 10 seconds.)
 (*5) When power to the motor is turned ON after shutting it OFF, current of about 6.0 A flows (for aprox.1~2ms).
 (*6) The max. value of current can be detected in the magnetic pole detection process or during collision or constraint. The condition continues for up to 10 seconds in the magnetic pole detection process. In this process the above current is required.
 (*7) The bottom surface is excluded.

495

PSEP / ASEP

Names

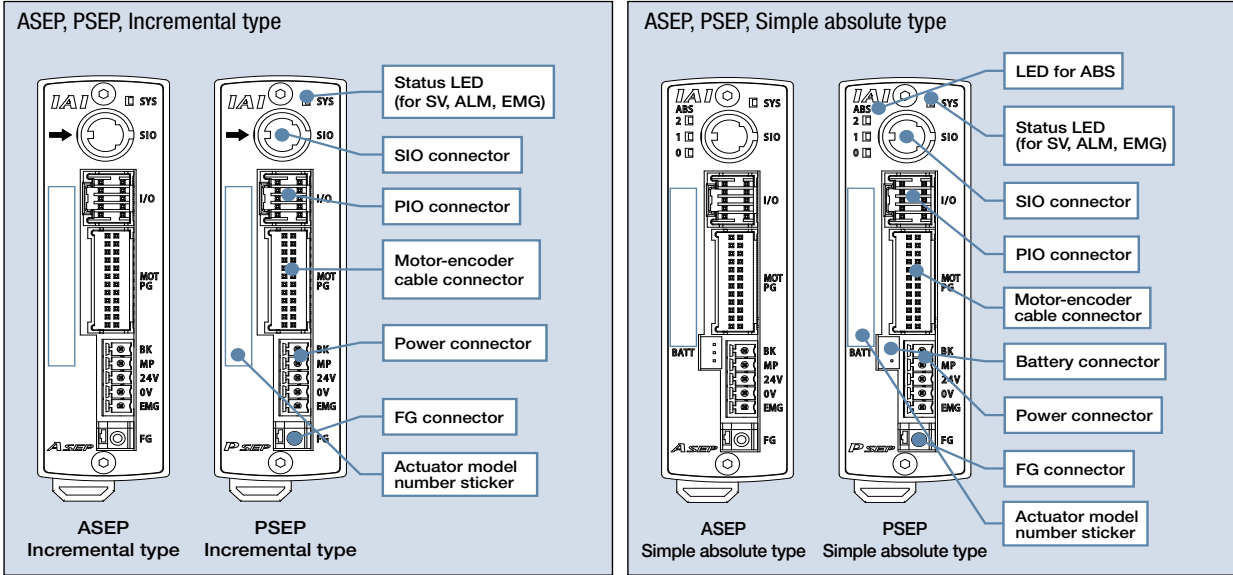

Outer dimensions

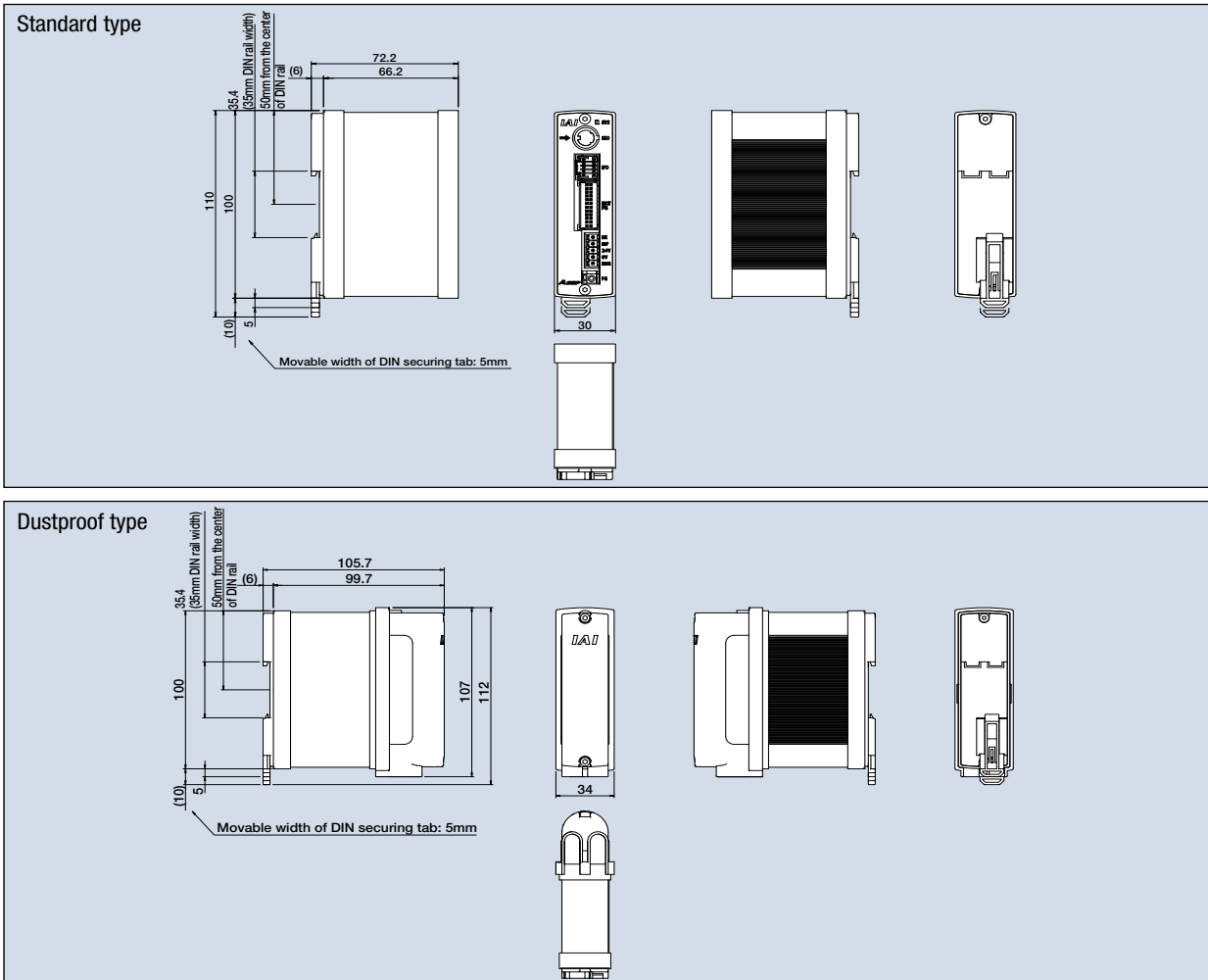

- Slider Type
- Mini
- Standard
- Controllers Integrated
- Rod Type
- Mini
- Standard
- Controllers Integrated
- Table/Arm /Flat Type
- Mini
- Standard
- Gripper/ Rotary Type
- Linear Servo Type
- Cleanroom Type
- Splash-Proof
- Controllers
- PMEC /AMEC
- PSEP /ASEP
- ROBO NET
- ERC2
- PCON
- ACON
- SCON
- PSEL
- ASEL
- SSEL
- XSEL
- Pulse Motor
- Servo Motor (24V)
- Servo Motor (200V)
- Linear Servo Motor



PSEP / ASEP **496**

Option

- Slider Type
- Mini
- Standard
- Controllers Integrated
- Rod Type
- Mini
- Standard
- Controllers Integrated
- Table/Arm /Flat Type
- Mini
- Standard
- Gripper/ Rotary Type
- Linear Servo Type
- Cleanroom Type
- Splash-Proof
- Controllers
- PMEC /AMEC
- PSEP /ASEP
- ROBO NET
- ERC2
- PCON
- ACON
- SCON
- PSEL
- ASEL
- SSEL
- XSEL
- Pulse Motor
- Servo Motor (24V)
- Servo Motor (200V)
- Linear Servo Motor

Touch Panel Teaching Pendant for Position Controller

- **Feature 1** A data input device with an intuitive touch panel menu screen that is easy to operate, even for first-time users. You can use it to configure settings such as home / end positions, intermediate position, speed, and pushing force, or to run an adjustment operation such as jogging, inching, and moving to a specified position.
- **Feature 2** Intuitive and interactive touch panel menus allow for easy configuration, even for first-time users.

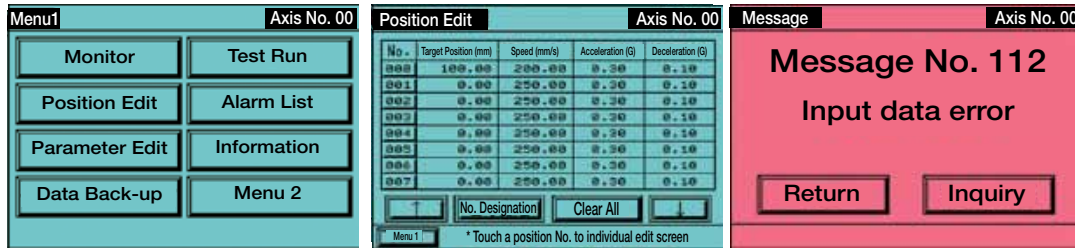

Large, easy to read display

Easy configuration with the touch panel

Backlight color changes when an error occurs

Model & Specifications

Item	Description			
Model	CON-PT-M-ENG	CON-PD-M-ENG	CON-PG-M-S-ENG	SEP-PT-ENG
Type	Standard type	Enable switch type	Safety compliant type	SEP controller dedicated type
Connectible controllers	PSEP/PCON/RPCON ASEP/ACON/RACON SCON/ERC2 (*)			PSEP ASEP
3-position enable switch	x	○	○	x
Functions	Input and edit position data Movement functions (move to specified position, jog, inch) Test input and output signals Edit parameters			
Display	3-color LED with backlight			
Operating ambient temp./Humidity	0~50°C 20~85% RH (non-condensing)			
Environmental resistance	IP40			
Weight (incl. 5m cable)	Approx. 750g	Approx. 780g	Approx. 780g	Approx. 550g
Accessories	• Touch pen	• Touch pen	• TP Adapter (Model: RCB-LB-TG) • Dummy Plug (Model: DP-4) • Controller connection cable (Model: CB-CON-LB005) • Touch pen	• Touch pen
Standard Price	-	-	-	-

(*) If an ERC2 type controller does not have "4904" on the serial number label, it cannot be connected.

Caution: If you have a "CON" type controller (i.e. PCON, RPCON, ACON, RACON, SCON, ERC2) and an "SEP" type controller (PSEP or ASEP) linked together, you cannot connect the teaching pendant to it.

Absolute battery unit for SEP controllers

Names of Parts/
Exterior
Dimensions

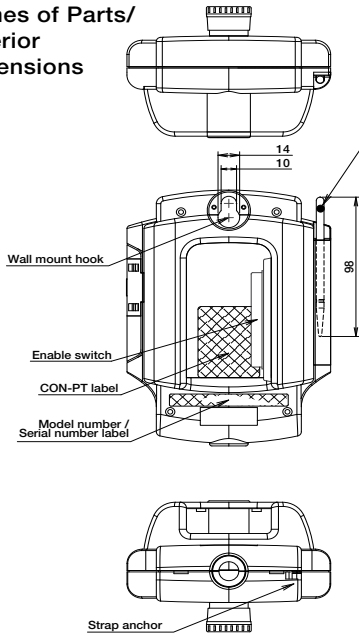

Option

- Strap Model STR-1

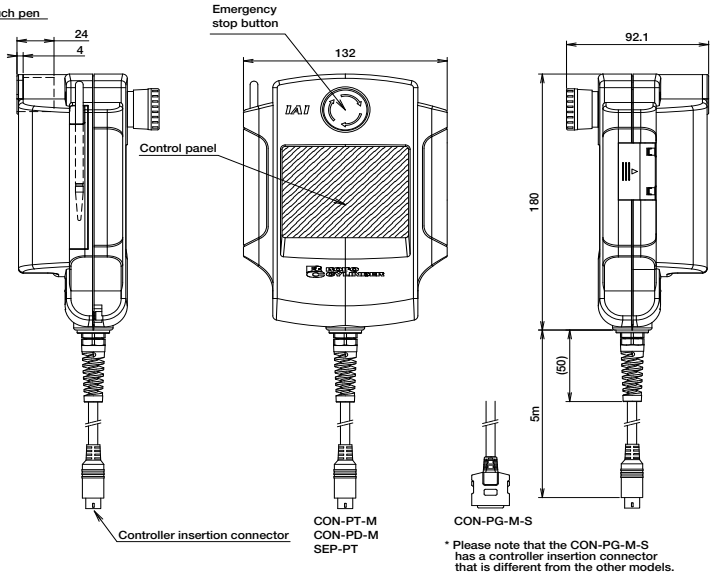

CON-PG-M-S Wiring Drawing

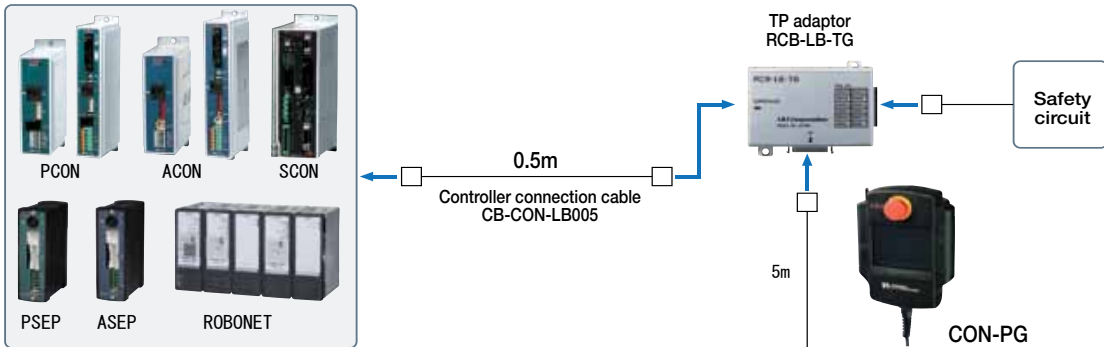

- Slider Type
- Mini
- Standard
- Controllers Integrated
- Rod Type
- Mini
- Standard
- Controllers Integrated
- Table/Arm /Flat Type
- Mini
- Standard
- Gripper/ Rotary Type
- Linear Servo Type
- Cleanroom Type
- Splash-Proof
- Controllers
- PMEC /AMEC
- PSEP /ASEP
- ROBO NET
- ERC2
- PCON
- ACON
- SCON
- PSEL
- ASEL
- SSEL
- XSEL

- Pulse Motor
- Servo Motor (24V)
- Servo Motor (200V)
- Linear Servo Motor

Option

PC Software (Windows Only)

- Features** A startup support software for inputting positions, performing test runs, and monitoring. With enhancements for adjustment functions, the startup time is shortened.

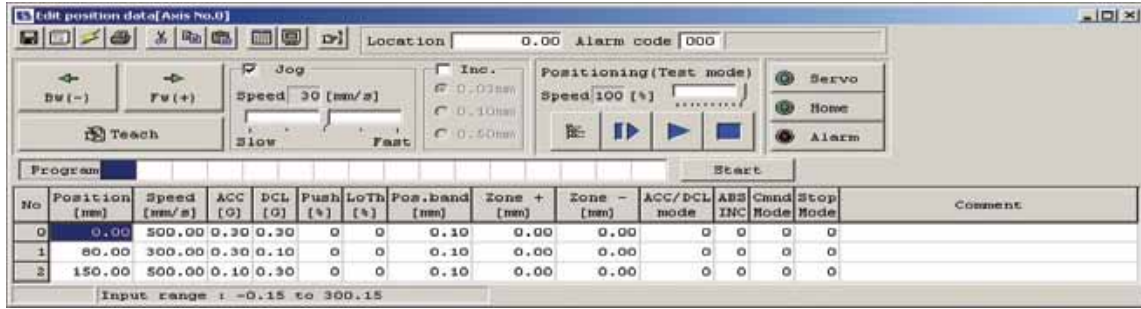

- Model RCM-101-MW**
(External device communication cable + RS232 conversion unit)



Configuration

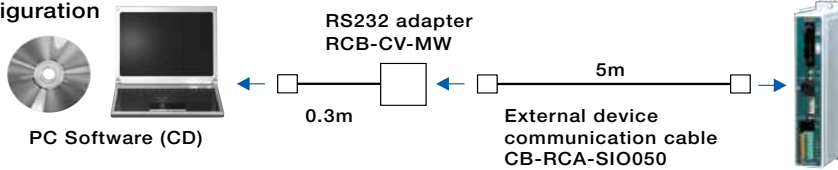

- Model RCM-101-USB**
(External device communication cable + USB adapter + USB cable)



Configuration

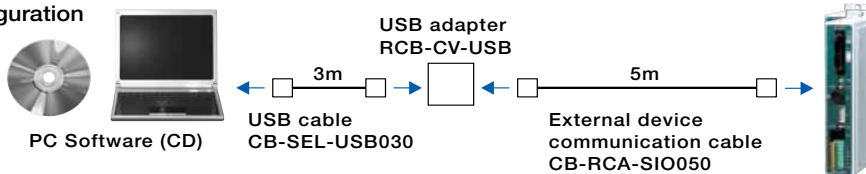

- Slider Type
- Mini
- Standard
- Controllers Integrated
- Rod Type
- Mini
- Standard
- Controllers Integrated
- Table/Arm /Flat Type
- Mini
- Standard
- Gripper/ Rotary Type
- Linear Servo Type
- Cleanroom Type
- Splash-Proof
- Controllers
- PMEC /AMEC
- PSEP /ASEP
- ROBO NET
- ERC2
- PCON
- ACON
- SCON
- PSEL
- ASEL
- SSEL
- XSEL
- Pulse Motor
- Servo Motor (24V)
- Servo Motor (200V)
- Linear Servo Motor

Absolute battery unit for SEP controllers

- Description** Supplied with the PSEP and ASEP simple absolute controllers. This is a battery unit used for backing up the current position data.
- Model** **SEP-ABU (standard type)**
SEP-ABU-W (dustproof type)

Specifications

Item	Specifications			
Ambient operating temp./Humidity	0~40°C (around 20°C preferred), 95% RH or below (non-condensing)			
Ambient operating environment	No corrosive gases			
Absolute battery (*1)	Model: AB-7 (Ni-MH battery/Approx. 3-year life)			
Controller-absolute battery unit cable (*1)	Model: CB-APSEP-AB005 (0.5m long)			
Weight	Standard type: Approx. 230g; Dustproof type: Approx. 260g			
Allowable encoder RPM during data retention (*2)	800rpm	400rpm	200rpm	100rpm
Position data retention duration (*2)	120h	240h	360h	480h

(*1) The absolute battery unit comes with a cable to connect the controller and the absolute battery unit.
 (*2) Position data retention time changes with the allowable encoder RPMs during data retention.
 (800rpm→120h, 400rpm→240h, 200rpm→360h, 100rpm→480h)

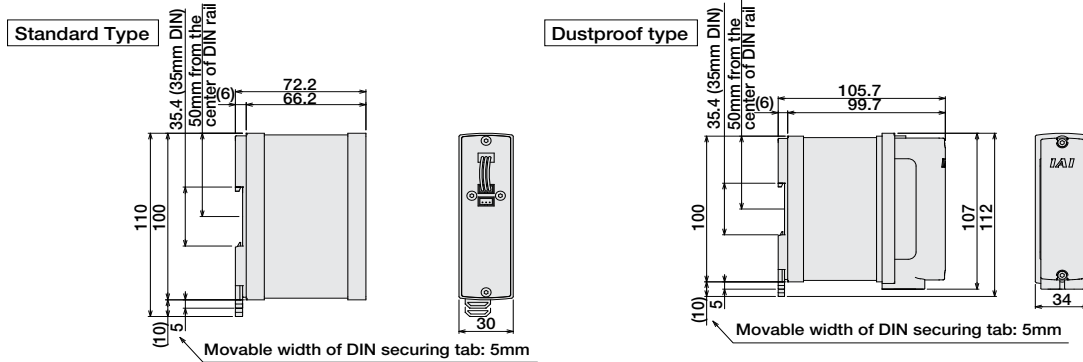

Cautions on Controllers and Options

- When mounting the controller to a DIN rail, use the supplied spacer between the controllers to prevent them from contacting each other, to deal with heat dissipation. (See Fig. 1)
 - When mounting the absolute battery units and controllers, place the absolute battery units below the controllers. (See Fig. 2)
- If there is not enough space below the controllers, mount the absolute battery units in such a way that the temperature around the controllers stays at 40°C or below.

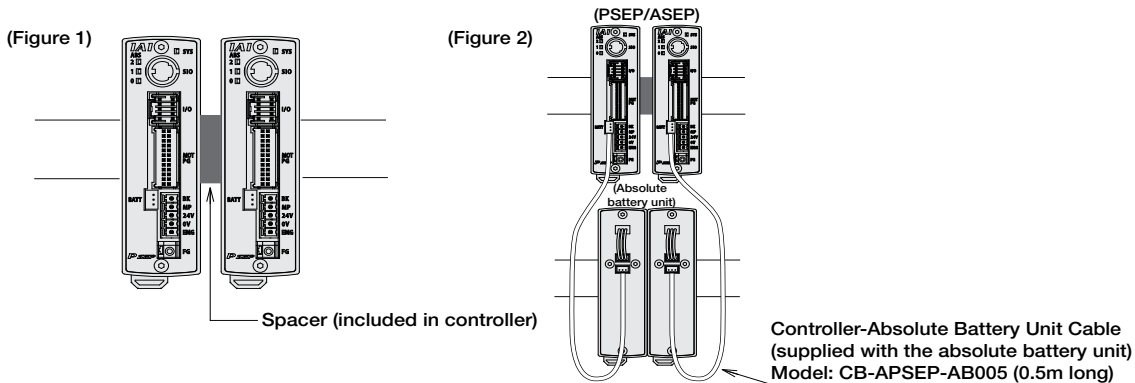

- Teaching pendants for PCON, ACON, and SCON (e.g. CON-T, RCM) cannot be used with PSEP or ASEP. For PSEP and ASEP, use the SEP-PT.
- The SEP-PT cannot communicate to the linked controllers. (Please connect them directly to the controller.)



PSEP / ASEP **500**

- Slider Type
- Mini
- Standard
- Controllers Integrated
- Rod Type
- Mini
- Standard
- Controllers Integrated
- Table/Arm /Flat Type
- Mini
- Standard
- Gripper/ Rotary Type
- Linear Servo Type
- Cleanroom Type
- Splash-Proof
- Controllers
- PMEC /AMEC
- PSEP /ASEP
- ROBO NET
- ERC2
- PCON
- ACON
- SCON
- PSEL
- ASEL
- SSEL
- XSEL
- Pulse Motor
- Servo Motor (24V)
- Servo Motor (200V)
- Linear Servo Motor

Spare parts

When you need spare parts after purchasing the product, such as when replacing a cable, refer to the list of models below.

Motor-encoder integrated cable for connecting [RCP3/RCA2/RCL] and [PSEP/ASEP]

Model **CB-APSEP-MPA**

* Enter the cable length (L) into . Compatible to a maximum of 20 meters.
Ex. 080 = 8m

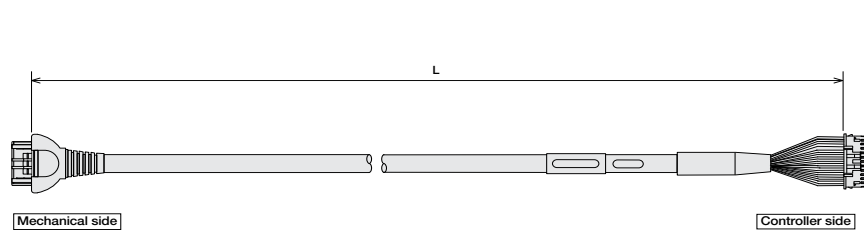

Min. bend radius $r = 68$ mm or larger (when movable type is used)

Mechanical side	(PCON) (ACON)	Controller side
Pin number		Pin number
A1	Black [ΦA](U)	1
B1	White [VM] (V)	2
A2	Brown [ΦA](W)	3
B2	Green [ΦB](-)	4
A3	Yellow [VM] (I)	5
B3	Red [ΦB](+)	6
A4	Orange [LS-] (BK+)	7
B4	Gray [LS-] (BK-)	8
A5	White [A+] (A+)	9
B5	Yellow [A-] (A-)	10
A6	Red [A+] (B+)	11
B6	Green [A-] (B-)	12
A7	Black [B+] (Z+)	13
B7	Brown [B-] (Z-)	14
A8	Black (label) [BK+] (LS+)	15
B8	Brown (label) [BK-] (LS-)	16
A9	Green (label) [GND] (LS)	17
B9	Red (label) [VPS] (VPS)	18
A10	White (label) [VCC] (VCC)	19
B10	Yellow (label) [GND] (GND)	20
A11	NC	21
B11	Shield [FG] (FG)	22
	NC	23
	NC	24

Motor-encoder integrated cable for connecting [RCP2] and [PSEP]

Model **CB-PSEP-MPA**

* Enter the cable length (L) into . Compatible to a maximum of 20 meters.
Ex. 080 = 8m

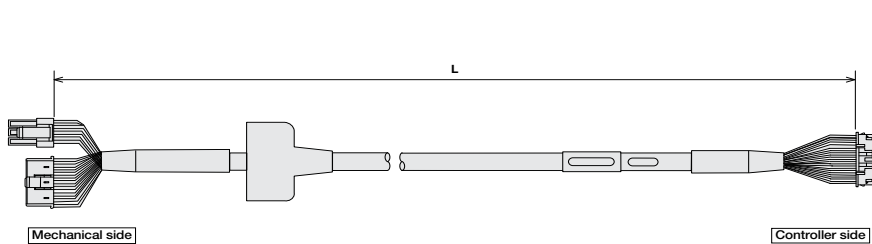

Min. bend radius $r = 68$ mm or larger (when movable type is used)

Mechanical side		Controller side
Pin number		Pin number
1	Black [ΦA]	1
2	White [VM] (V)	2
3	Green [VM] (I)	3
4	Brown [ΦA]	4
5	Yellow [ΦB]	5
6	Orange [BK+] (LS+)	6
7	Gray [BK-] (LS-)	7
8	NC	8
9	White [A+] (A+)	9
10	Yellow [A-] (A-)	10
11	Red [B+] (B+)	11
12	Green [B-] (B-)	12
13	White (label) [VCC]	13
14	Yellow (label) [VPS]	14
15	Red (label) [GND]	15
16	Green (label) (spare)	16
17	NC	17
18	NC	18
19	NC	19
20	NC	20
21	NC	21
22	NC	22
23	NC	23
24	Shield [FG]	24

Motor-encoder integrated type cable for RCP3/RCP2 (Limited to RCP2-GRSS/GRLS/GRST/SRA4R/SRGS4R/SRGD4R types)

Model **CB-PCS-MPA**

* Enter the cable length (L) into . Compatible to a maximum of 20 meters.
Ex. 080 = 8m

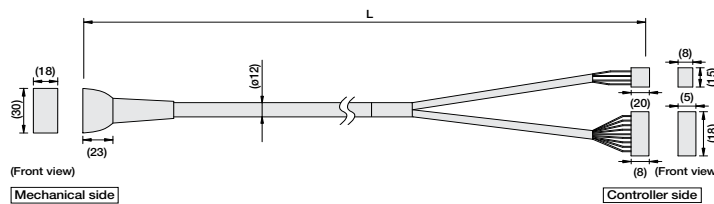

Min. bend radius $r = 84$ mm or larger (when movable type is used)

Pin Number	Signal	(Wire color)	Signal	Pin Number
A1	A	Black	A	B1
B1	VMM	White	VMM	A2
A2	/A	Red	/A	A1
B2	B	Green	B	B3
A3	VMM	Yellow	VMM	B2
B3	/B	Brown	/B	A3
A4	NC			
B4	BK+	Pink (Red ●)	BK+	14
A5	BK-	Pink (Blue ●)	BK-	13
B5	BK-	White (Red ●)	LS+	16
A6	LS+	White (Blue ●)	LS-	15
B6	LS-	Orange (Red ●)	A+	12
A7	A+	Orange (Blue ●)	A-	11
B7	A-	Gray (Red ●)	B+	10
A8	B+	Gray (Blue ●)	B-	9
B8	B-		NC	8
A9	NC		VPS	7
B9	VPS	Orange (Blue ● Consecutive)	VCC	6
A10	VCC	Gray (Red ● Consecutive)	GND	5
B10	GND	Gray (Blue ● Consecutive)	NC	4
A11	NC		FG	1
B11	FG	Shield		

Motor-encoder integrated cable for connecting [RCA] and [ASEP]

Model **CB-ASEP-MPA**

* Enter the cable length (L) into . Compatible to a maximum of 20 meters.
Ex. 080 = 8m

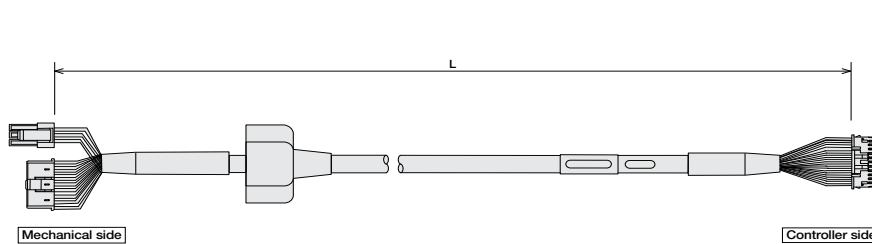

Min. bend radius $r = 68$ mm or larger (when movable type is used)

Mechanical side		Controller side
Pin number		Pin number
1	Red [U]	1
2	Yellow [V]	2
3	NC	3
4	NC	4
5	Black [W]	5
6	NC	6
7	Orange [BK+] (LS+)	7
8	Gray [BK-] (LS-)	8
9	White [A+] (A+)	9
10	Brown [LS-] (LS-)	10
11	White [A+] (A+)	11
12	Yellow [A-] (A-)	12
13	Red [B+] (B+)	13
14	Green [B-] (B-)	14
15	Black (label) [Z+] (Z+)	15
16	Brown (label) [Z-] (Z-)	16
17	White (label) [VCC]	17
18	Yellow (label) [VPS]	18
19	Red (label) [GND]	19
20	Green (label) (spare)	20
21	NC	21
22	NC	22
23	NC	23
24	Shield [FG]	24

501

PSEP / ASEP

Motor-encoder integrated cable for connecting [RCA2/RCL] and [ACON/RACON/ASEL]

Model **CB-ACS-MPA**

* Enter the cable length (L) into . Compatible to a maximum of 20 meters.
Ex. 080 = 8m

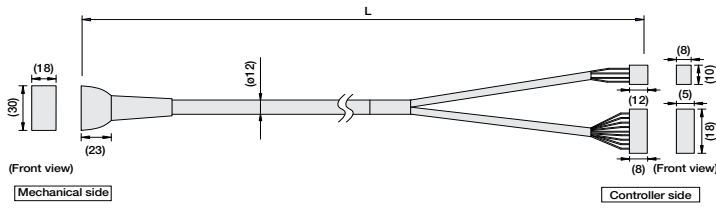

Min. bend radius r = 84 mm or larger (when movable type is used)

Pin Number	Signal	(Wire color)	Signal	Pin Number
A1	U	Red	U	2
B1	V	Yellow	V	2
A2	W	Black	W	3
B2	NC			
A3	NC			
B3	NC			
A4	BK-	Yellow (Red ●)	BK+	16
B4	BK-	Yellow (Blue ●)	BK-	15
A5	LS+	Pink (Red ●)	LS+	18
B5	LS+	Pink (Blue ●)	LS-	17
A6	A+	White (Red ●)	A+	14
B6	A-	White (Blue ●)	A-	13
A7	B+	Orange (Red ●)	B+	12
B7	B-	Orange (Blue ●)	B-	11
A8	Z+	Gray (Red ●)	Z+	10
B8	Z-	Gray (Blue ●)	Z-	9
A9	-	Orange (Red ● Consecutive)	-	8
B9	/PS	Orange (Blue ● Consecutive)	/PS	7
A10	VCC	Gray (Red ● Consecutive)	VCC	6
B10	GND	Gray (Blue ● Consecutive)	GND	5
A11	NC		NC	
B11	FG		FG	1

Motor-encoder integrated cable for connecting [RCP2 mini rotary] and [PSEP]

Model **CB-RPSEP-MPA**

* Enter the cable length (L) into . Compatible to a maximum of 20 meters.
Ex. 080 = 8m

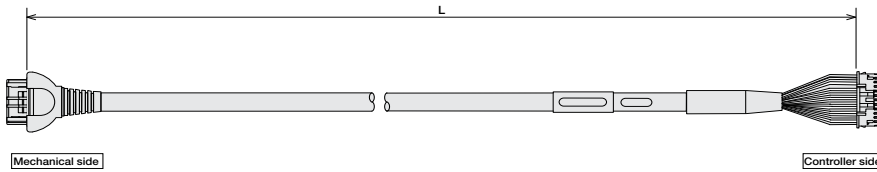

Min. bend radius r = 68 mm or larger (when movable type is used)

Mechanical side Pin number	Signal	Controller side Pin number
A1	Black [0A]	1
B1	White [VMM]	2
A2	Brown [0/A]	5
B2	Green [0B]	3
A3	Yellow [VMM]	4
B3	Red [0/B]	6
A6	Orange [LS+]	7
B6	Gray [LS-]	8
A7	Red [A+]	13
B7	Green [A-]	14
A8	Black [B+]	15
B8	Brown [B-]	16
A4	NC	7
B4	NC	8
A5	Black (label) [BK+]	9
B5	Brown (label) [BK-]	10
A9	Green (label) [CHDLS]	20
B9	Red (label) [VPS]	18
A10	White (label) [VCC]	17
B10	Yellow (label) [GND]	19
A11	NC	21
B11	Shield [FG] (FG)	24
	NC	22
	NC	23

I/O cable for PSEP-C/ASEP-C

Model **CB-APSEP-PIO**

* Enter the cable length (L) into . Compatible to a maximum of 10 meters.
Ex. 080 = 8m

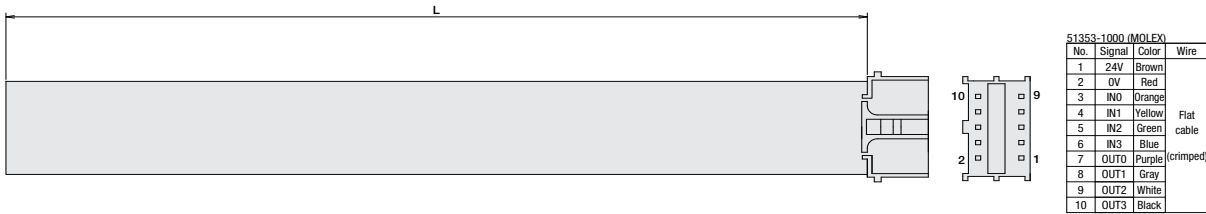

I/O cable for PSEP-CW/ASEP-CW

Model **CB-APSEPW-PIO**

* Enter the cable length (L) into . Compatible to a maximum of 10 meters.
Ex. 080 = 8m

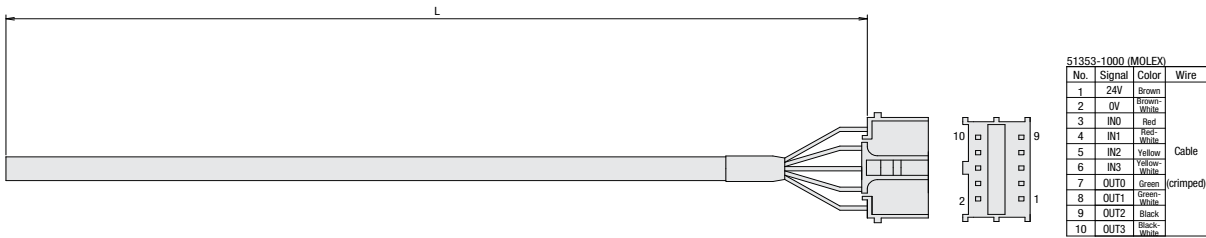

- Slider Type
- Mini
- Standard
- Controllers Integrated
- Rod Type
- Mini
- Standard
- Controllers Integrated
- Table/Arm /Flat Type
- Mini
- Standard
- Controllers Integrated
- Gripper/ Rotary Type
- Linear Servo Type
- Cleanroom Type
- Splash-Proof
- Controllers
- PMEC /AMEC
- PSEP /ASEP
- ROBO NET
- ERC2
- PCON
- ACON
- SCON
- PSEL
- ASEL
- SSEL
- XSEL
- Pulse Motor
- Servo Motor (24V)
- Servo Motor (200V)
- Linear Servo Motor

ROBO NET



■ Model :RGW-□/RACON/RPCON/RABU/REXT

For RCA2/RCA/RCL/RCP3/RCP2
Network Controller

ROBONET is a new type of control unit that freely operates ROBO Cylinders via a field network. They have less wiring and are more compact than past controllers, and by DIN rail mounting make it possible to vastly reduce wiring and installation labor.

Features

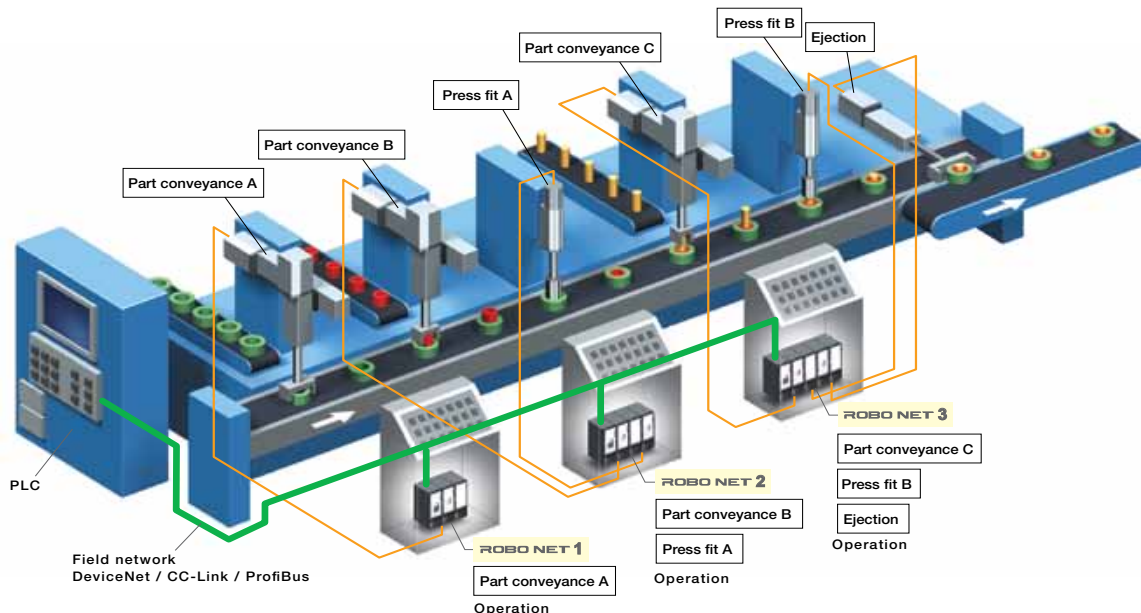

1 Reduced Wiring

By connecting each line of the I/O cables to lines wired to the PLC terminals with the field network, wiring processing is completed with one dedicated cable. Also, since the unit can be coupled by just connecting with the unit connection board, the controller wiring work is greatly simplified.

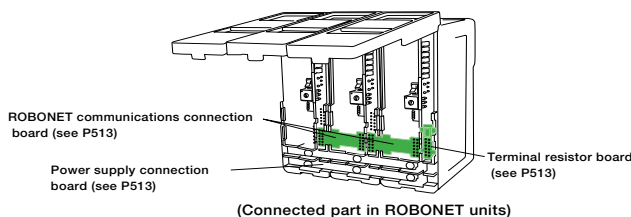
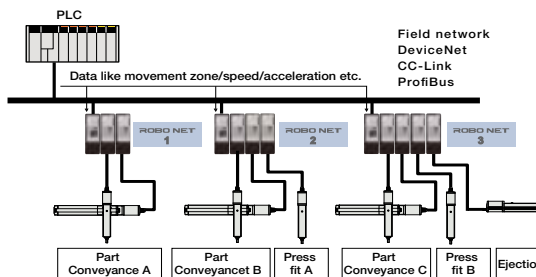

503 ROBONET

- Slider Type
- Mini
- Standard
- Controllers Integrated
- Rod Type
- Mini
- Standard
- Controllers Integrated
- Table/Arm /Flat Type
- Mini
- Standard
- Gripper/ Rotary Type
- Linear Servo Type
- Cleanroom Type
- Splash-Proof
- Controllers
- PMEC /AMEC
- PSEP /ASEP
- ROBO NET
- ERC2
- PCON
- ACON
- SCON
- PSEL
- ASEL
- SSEL
- XSEL
- Pulse Motor
- Servo Motor (24V)
- Servo Motor (200V)
- Linear Servo Motor

2 The robot can be moved by directly specifying numeric values for the move position/velocity/acceleration and other data.

Besides the conventional method of moving the robot to pre-taught positions it is also possible to operate the robot by sending information as a string of numeric data that contains position, velocity, acceleration, etc. values. This is effective for cases such as when the move position changes with each piece or when one wants to move the robot to an arbitrary position.

	ROBONET controller	Standard controller (ACON/PCON)
Movement by specifying positions	○	○
Movement by specifying direct values	○	△
Specifying speed/acceleration	○	(Not for PIO) (Connectable with serial communication)
Current value output	○	

*ROBONET operates through a field network, and the standard controller operates with PIO.

3 Ultra-compact

Each unit is an ultra-compact size of 34mm wide by 100mm high x 73mm deep. Also, since there is no base unit and the main unit is coupled with connectors, the controller takes up little space for installation even if there are many units.



4 Can operate with a maximum of 16 axes.

Up to 16 controllers can be connected to one communication unit (Gateway R unit). RACON units (controllers for RCA) and RPCON units (controllers for RCP2) can also be used together.

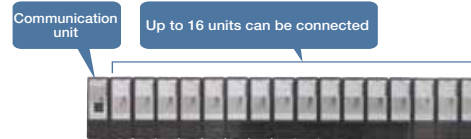

5 Controllers can be multiplexed.

Controllers can be multiplexed using an optional extension unit, so many axes can be connected even if there isn't much horizontal space. Also, non-ROBONET controllers (SCON, PCON-CF, ERC2) can be connected to a ROBONET Gateway unit using the same extension unit.

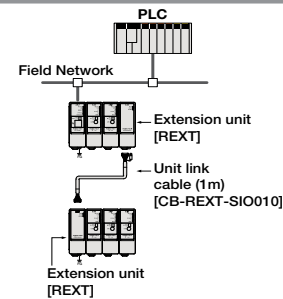

6 Simple absolute unit, when home return is not required

The simple absolute R unit allows operation for incremental specification axes without home return. Users can back up actuator encoder data even if the power is shut off, by installing a simple absolute R unit to a RACON unit (controller for RCA) or RPCON unit (controller for RCP2).



7 Mounting the DIN rail

The controller is installed with DIN rails, so it can be fastened and removed with one touch.

- Slider Type
- Mini
- Standard
- Controllers Integrated
- Rod Type
- Mini
- Standard
- Controllers Integrated
- Table/Arm/Flat Type
- Mini
- Standard
- Gripper/Rotary Type
- Linear Servo Type
- Cleanroom Type
- Splash-Proof
- Controllers
- PMEC/AMEC
- PSEP/ASEP
- ROBO NET
- ERC2
- PCON
- ACON
- SCON
- PSEL
- ASEL
- SSEL
- XSEL
- Pulse Motor
- Servo Motor (24V)
- Servo Motor (200V)
- Linear Servo Motor

System configuration

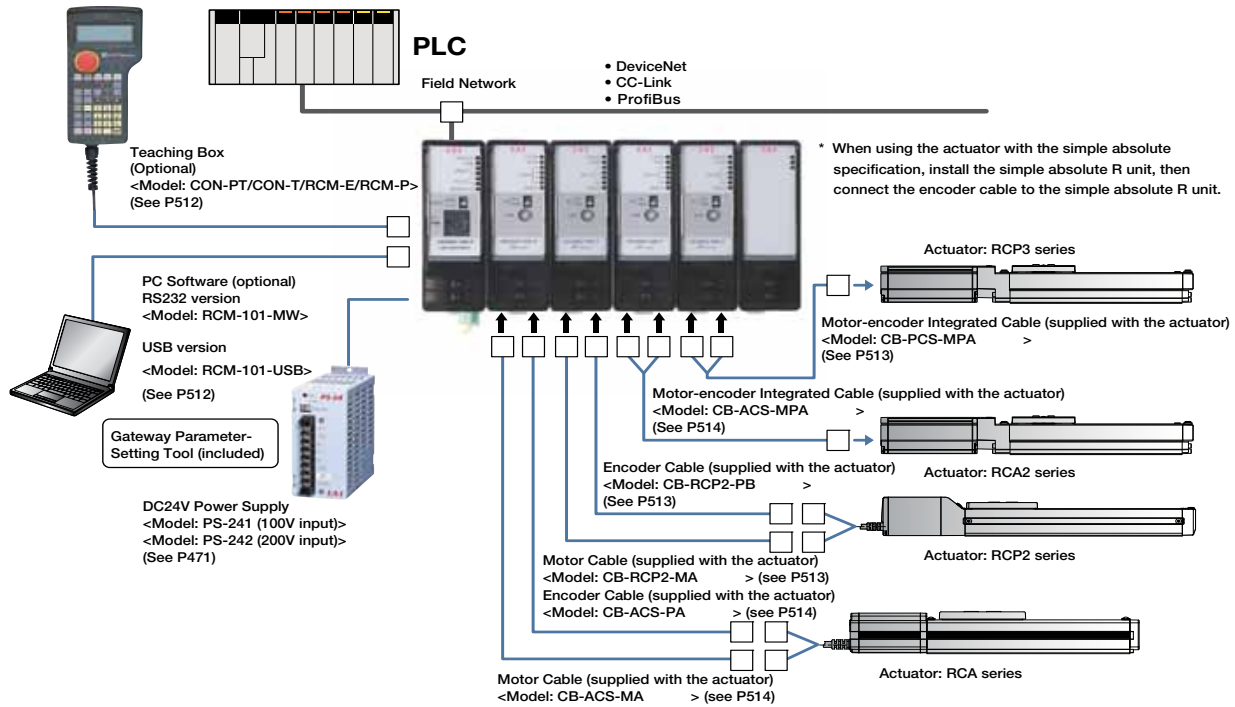

ROBONET Extension Unit

If multiple ROBONET extension units (optional) are linked together they can reduce the lateral width needed. It is also possible to connect individual controllers, such as SCON, etc. via the ROBONET.

[Unit Multiplex Set]

Model: REXT-SIO

(Set Contents)

ROBONET Extension Unit (Model: REXT) 2 pc
Unit Link Cable (Model: CB-REXT-SIO010) 1 pc

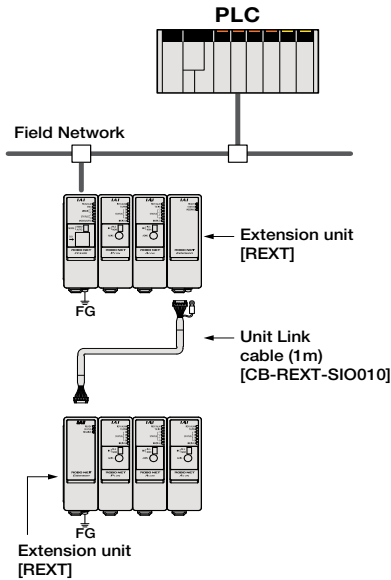

[Controller Connecting Set]

Model: REXT-CTL

(Set Contents)

ROBONET Extension Unit (Model: REXT) 1 pc
Controller Connection Cable (Model: CB-REXT-CTL010) 1 pc

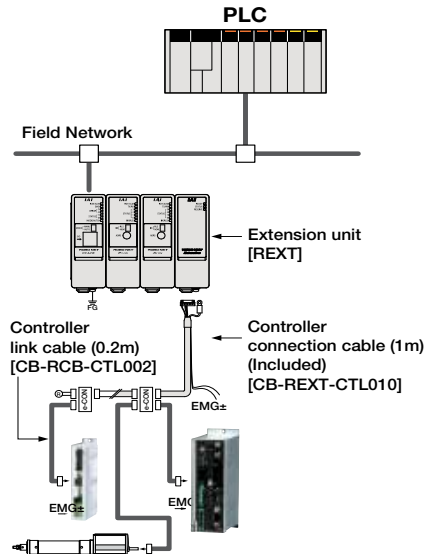

505

ROBONET

- Slider Type
- Mini
- Standard
- Controllers Integrated
- Rod Type
- Mini
- Standard
- Controllers Integrated
- Table/Arm /Flat Type
- Mini
- Standard
- Gripper/ Rotary Type
- Linear Servo Type
- Cleanroom Type
- Splash-Proof
- Controllers
- PMEC /AMEC
- PSEP /ASEP
- ROBO NET
- ERC2
- PCON
- ACON
- SCON
- PSEL
- ASEL
- SSEL
- XSEL
- Pulse Motor
- Servo Motor (24V)
- Servo Motor (200V)
- Linear Servo Motor

Configuration unit

Required ROBONET units are ordered individually, and assembled as you see fit. If actuators are added later, they can be easily added simply by adding a RACON/RPCON unit.



Unit Name	Description	See Page
Gateway R unit	This unit is for connecting to a field network. Users can select from 4 types: DeviceNet, CC-Link, ProfiBus, and SIO. *This unit is required for using ROBONET.	P508 P509
RACON unit	This controller operates the RCA actuator. (One unit is necessary per actuator axis.) The incremental specification is the standard, but the simple absolute specification can also be used if the simple absolute R unit is used with it.	P510
RPCON unit	This controller operates the RCP2 actuator. (One unit is necessary per actuator axis.) The incremental specification is the standard, but the simple absolute specification can also be used if the simple absolute R unit is used with it.	P510
Simple absolute R unit	This is the back-up battery unit that retains actuator encoder data when the power is turned off.	P511
Extension unit	This unit makes it possible to reverse ROBONET connections, connect unit controllers (SCON/PCON-CF) to ROBONET, and conduct operation from a network.	P511

Ordering Method/Precautions

Required ROBONET units are ordered individually and assembled by the customer. Consequently, they can be added to or changed later.

<Ordering example> The following 2 actuator axes can be operated through CC-Link. The models that would be best operated with the absolute specification are as follows.

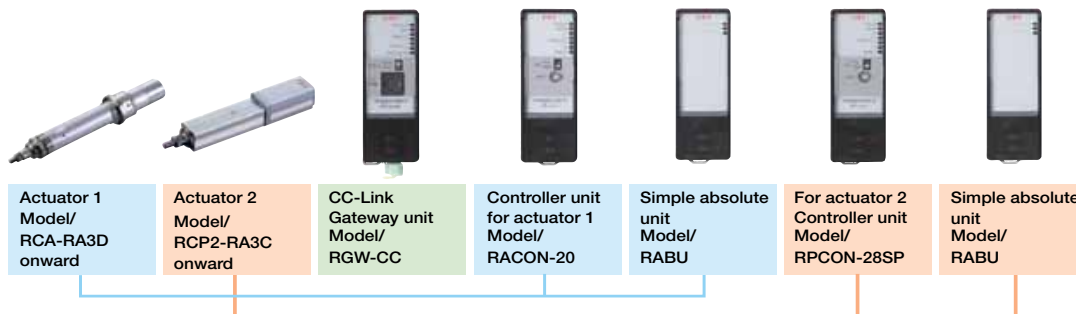

- Gateway Parameter Setting Tool**

A gateway parameter setting tool is necessary to set up the network when ROBONET is connected to a field network. This tool can be acquired at no cost.

 - Download from the IAI website, or
 - Acquire PC compatible software (included on CD).

A cable (cable included with PC software, model: CB-RCA-SIO050+RCB-CV-MW) is required to connect the PC to the controller when using the gateway parameter setting tool. If you do not have the PC software, please purchase a cable.
- PC Compatible Software Teaching Pendant**

Compatible PC software or a teaching pendant is required to enter position data, etc. to a ROBONET controller unit. ROBONET compatible PC software (Model: RCM-101-MW/USB) version is Ver. 6.00.04.00 or later. Teaching pendant compatible models and versions include: RCM-T and Ver. 2.06 and later, model: RCM-E/RCM-P and Ver. 2.08 and later. Model: CON-T is compatible with all versions from the earliest version. Consult with our Sales Division if the version your equipment has needs to be updated.

Operation Mode

ROBONET operates upon receiving commands from the PLC via the field network.

The following four operating modes are available. Select the most suitable mode for the operation or the control method.

	Name	Description
1	Positioner mode (1,2)	In this mode, operation is done by specifying position numbers, whose position data, speed, and acceleration have been entered to the position table in advance. A maximum of 768 position points can be saved.
2	Simple direct input mode	The position data is specified directly using a numerical value; the other settings, such as speed, acceleration, deceleration, positioning band, and pushing current limit are specified using a predefined position number. A maximum of 768 position points can be saved.
3	Direct input mode	The position data, speed, acceleration, deceleration, positioning band, and pushing current limit are all specified directly using numerical values. Since the settings are specified by their numerical values, there is no limit to the number of points that can be set.
4	Solenoid valve mode (1,2)	The number of positioning points is limited for a simpler operation. You can operate it using the same controls as a solenoid valve, just by sending a command with the target position number (start signal not required).

List of functions for operation modes

Item	Operation mode	Positioner 1 Mode	Simple immediate data Mode	Direct number designation mode	Positioner 2 Mode	Solenoid Valve Mode 1	Solenoid Valve Mode 2
Each axis field (both input and output)		4 words		8 words	2 words	2 words	
Fixed field (both input and output)		8 words (Command field usable)		8 words (Command field not usable)	8 words (Command field usable)	8 words (Command field usable)	
Number of set positions		768 positions/axis	768 positions/axis	-	768 positions/axis	7 positions/axis	3 positions/axis
Position No. designation operation		<input type="radio"/>	<input type="radio"/>	<input checked="" type="radio"/>	<input type="radio"/>	<input type="radio"/>	<input type="radio"/>
Position data direct designation		<input checked="" type="radio"/>	<input type="radio"/>	<input type="radio"/>	<input checked="" type="radio"/>	<input type="radio"/>	<input checked="" type="radio"/>
Direct designation of speed and acceleration/deceleration speed		<input checked="" type="radio"/>	<input checked="" type="radio"/>	<input type="radio"/>	<input checked="" type="radio"/>	<input type="radio"/>	<input checked="" type="radio"/>
Direct designation of positioning band		<input checked="" type="radio"/>	<input checked="" type="radio"/>	<input type="radio"/>	<input checked="" type="radio"/>	<input type="radio"/>	<input checked="" type="radio"/>
Pushing operation		<input type="radio"/>	<input type="radio"/>	<input type="radio"/>	<input type="radio"/>	<input type="radio"/>	<input type="radio"/>
Completed position No. monitor		<input type="radio"/>	<input type="radio"/>	<input checked="" type="radio"/>	<input type="radio"/>	<input type="radio"/>	<input type="radio"/>
Zone output monitor		<input type="radio"/>	<input type="radio"/>	<input type="radio"/>	<input type="radio"/>	<input type="radio"/>	<input type="radio"/>
Position zone output monitor		<input type="radio"/>	<input type="radio"/>	<input checked="" type="radio"/>	<input type="radio"/>	<input type="radio"/>	<input type="radio"/>
Teaching function		<input type="radio"/>	<input checked="" type="radio"/>	<input checked="" type="radio"/>	<input type="radio"/>	<input type="radio"/>	<input checked="" type="radio"/>
Jog operation		<input type="radio"/>	<input type="radio"/>	<input type="radio"/>	<input type="radio"/>	<input type="radio"/>	<input checked="" type="radio"/>
Incremental operation		<input type="radio"/>	<input type="radio"/>	<input type="radio"/>	<input type="radio"/>	<input type="radio"/>	<input checked="" type="radio"/>
Status signal monitor (*1)		<input type="radio"/>	<input type="radio"/>	<input type="radio"/>	<input type="radio"/>	<input type="radio"/>	<input checked="" type="radio"/>
Current position monitor (*1)		<input type="radio"/>	<input type="radio"/>	<input type="radio"/>	<input type="radio"/>	<input type="radio"/>	<input checked="" type="radio"/>
Alarm code monitor (*1)		<input type="radio"/>	<input type="radio"/>	<input type="radio"/>	<input type="radio"/>	<input type="radio"/>	<input checked="" type="radio"/>
Speed and current monitor (*1)		<input checked="" type="radio"/>	<input checked="" type="radio"/>	<input type="radio"/>	<input checked="" type="radio"/>	<input type="radio"/>	<input checked="" type="radio"/>
Each axis monitoring function in in AUTO mode (*2)		<input type="radio"/>	<input type="radio"/>	<input type="radio"/>	<input type="radio"/>	<input type="radio"/>	<input type="radio"/>
Command	Hand shake	<input type="radio"/>	<input type="radio"/>	<input checked="" type="radio"/>	<input type="radio"/>	<input type="radio"/>	<input type="radio"/>
	Position table Reading/writing of data	<input type="radio"/>	<input type="radio"/>	<input checked="" type="radio"/>	<input type="radio"/>	<input type="radio"/>	<input type="radio"/>
	Reading the current position	<input checked="" type="radio"/>	<input checked="" type="radio"/>	<input checked="" type="radio"/>	<input checked="" type="radio"/>	<input type="radio"/>	<input checked="" type="radio"/>
	Broadcast	<input type="radio"/>	<input checked="" type="radio"/>	<input checked="" type="radio"/>	<input type="radio"/>	<input type="radio"/>	<input type="radio"/>
Max. value for position data designation		9999.99mm (When command is used)	9999.99mm	9999.99mm	9999.99mm (When command is used)	9999.99mm (When command is used)	
Number of axes that can be connected		16	16	8	16	16	

*1: Each status signal monitor, current position monitor, alarm code monitor, and speed/current monitor can be viewed by accessing to each address of Gateway unit via PLC.

*2: Traditionally, monitoring each axis in AUTO mode is unavailable. However, monitoring each axis with Mode switch at "AUTO" is available with ROBONET by connecting the special touch panel to the TP connector.

*3: Independent acceleration and deceleration settings are not available. The setting applies to both accelerating and decelerating speeds.

507

ROBONET

Configuration unit (Gateway R unit)

Gateway R Unit for DeviceNet



A communications unit to operate ROBONET via DeviceNet.

Model RGW-DV

Specifications	Item	Specifications	Item	Specifications					
	Power	DC24V ±10%	DeviceNet Specifications	Comm. cable length (*1)	Comm. Speed	Max. network length	Max. branch length	Total branch length	
Current consumption		600mA max.			500kbps	100m	6m	39m	
DeviceNet Specifications		Comm. Standard			DeviceNet 2.0-certified interface module			125kbps	500m
					Group 2 only server		156m		
DeviceNet Specifications	Insulated node operating on network power supply		Note: When using a large cable for DeviceNet						
	Comm. Spec.	Master-slave connection	Environment Requirements	No. occupied nodes	1 node				
				Ambient op. temperature	0~40°C				
				Ambient op. humidity	95% RH or below (non-condensing)				
Comm. Speed	500k/250k/125kbps (switchable by software)	Ambient op. environment	No corrosive or flammable gasses, oil mist, or dust.						
Protection class		IP20							
Weight		140g							
Accessories		Terminal resistor board (model TN-1) Network connector, Emergency stop connector							

*1 If you wish to use T-junction communication, see the instructions manual for your master unit or PLC.

Network cable

Connector on Gateway Side
MSTBA2.5/5-G-5.08 ABGY AU
(Made by: Phoenix Contact)

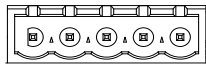

Connector on Cable Side
MSTB2.5/5-ST-5.08 ABGY AU
(Made by: Phoenix Contact)
= Standard accessory



Pin Color	Description
Black	Power cable negative (-) side
Blue	Comm. data Low side
-	Shield
White	Comm. data High side
Red	Power cable plus (+) side

Cable connector-compatible wiring

Item	Description
Wire diameter	Twisted wire: AWG24-12 (0.2~2.5mm ²)
Stripped wire length	7mm

Gateway R Unit for CC-Link



A communications unit to operate ROBONET via CC-Link.

Model RGW-CC

Specifications	Item	Specifications	Item	Specifications			
	Power Supply	DC24V ±10%	CC-Link Specifications	Error Control Method	CRC (X ¹⁶ +X ¹² +X ⁵ +1)		
Current consumption		600mA max.			Station occupancy	Remote device stations: x1, 4 st.; x4, 2 st.; x8, 2 st	
Comm. Standard		CC-Link Ver2.0 (*1)			Comm. Cable Length (*2)	Comm. Speed (bps)	10M 5M 2.5M 625k 156k
		Comm. Speed				10M/5M/2.5M/625k/156kbps (switchable by software)	Total Cable Length (m)
Comm. Method	Broadcast polling method	Comm. Cable	Dedicated CC-Link cable				
Sync. Method	Frame synchronization method	Environment Requirements	Ambient op. temperature	0~40°C			
Encoding Method	NRZI		Ambient op. humidity	95% RH or below (non-condensing)			
Transf. Type	Bus format (EIA RS485 compliant)		Ambient op. environment	No corrosive or flammable gasses, oil mist, or dust.			
Transf. Format	HDLC compliant		Protection class	IP20			
Weight		140g					
Accessories		Terminal resistor board (model TN-1) Network connector, Emergency stop connector Terminal resistor cable (110Ω/130Ω)					

*1 Certification acquired
*2 If you wish to use T-junction communication, see the instruction manual for your master unit or PLC.

Network cable

Connector on Gateway Side: Connector on Cable Side:
MSTBA2.5/5-G-5.08AU MSTB2.5/5-ST-5.08 ABGY AU
(Made by Phoenix Contact) (Made by Phoenix Contact) =
Standard accessory

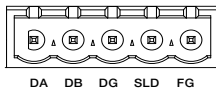

Signal Name	Description
DA	Communication line A
DB	Communication line B
DG	Ground
SLD	The shield and cable's shield are connected, then they are connected to "FG" and the chassis.
FG	Frame ground Connected to "SLD" and the chassis.

Cable connector-compatible wiring

Item	Description
Wire diameter	Twisted wire: AWG24-12 (0.2~2.5mm ²)
Stripped wire length	7mm

- Slider Type
- Mini
- Standard
- Controllers Integrated
- Rod Type
- Mini
- Standard
- Controllers Integrated
- Table/Arm /Flat Type
- Mini
- Standard
- Gripper/ Rotary Type
- Linear Servo Type
- Cleanroom Type
- Splash-Proof
- Controllers
- PMEC /AMEC
- PSEP /ASEP
- ROBO NET
- ERC2
- PCON
- ACON
- SCON
- PSEL
- ASEL
- SSEL
- XSEL
- Pulse Motor
- Servo Motor (24V)
- Servo Motor (200V)
- Linear Servo Motor

Gateway R Unit for ProfiBus



A communications unit to operate ROBONET via ProfiBus.

Model RGW-PR

Item	Specifications	Item	Specifications	
Power Supply	DC24V ±10%	Environment Requirements	Ambient op. temperature	
Current Consumption	600mA max.		Ambient op. humidity	
Comm. Standard	DP slave		Ambient op. environment	
Comm. Speed	9.6kbps-12Mbps	Protection class	IP20	
ProfiBus Specifications	9.6kbps	1500m	Weight	140g
	500kbps	400m	Accessories	Terminal resistor board (model TN-1) Emergency stop connector
	1.5Mbps	200m		
	3Mbps	200m		
12Mbps	100m			

Network cable

Connector on Gateway Side: 5 1
D-Sub connector, 9-pin socket side

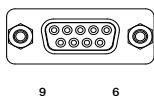

Pin No.	Signal Name	Description	Pin No.	Signal Name	Description
3	B-Line	Communication line B (RS485)	6	+5V	+5V output (insulated)
4	RTS	Request send	8	A-Line	Communication line A (RS485)
5	GND	Signal ground (insulated)	Housing	Shield	Connected to the cable's shield and the chassis.

* The matching connector (D-Sub 9-pin connector) is not included. * Pins 1, 2, 7, and 9 are not connected

Gateway R Unit for SIO



A communications unit for operating ROBONET from an XSEL controller or a Modbus-compatible communications unit, via serial communication.

Model RGW-SIO

Item	Specifications	Item	Specifications
Power Supply	DC24V ±10%	Environment Requirements	Ambient op. temperature
Current consumption	600mA max.		Ambient op. humidity
Comm. Type	RS485-compliant (Modbus protocol) 1:1 communication connection		Ambient op. environment
Comm. Method	Asynchronous method, half-duplex	Protection class	IP20
Comm. Speed	230.4kbps max.	Weight	140g
Cable Length	100m or less	Accessories	Terminal resistor board (model TN-1) Network connector, Emergency stop connector
Recommended cable	2 pairs of twisted pair cables (shielded)		

Network cable

Connector on Gateway Side
MC1.5/4-G-3.5
(Made by Phoenix Contact)

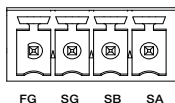

Connector on Cable Side:
MC1.5/4-ST-3.5
(Made by Phoenix Contact)
= Standard accessory

Signal Name	Description
SA	Communication line A (+positive side) Built-in RS485-compliant terminal resistor (220Ω)
SB	Communication line B (-negative side)
SG	Signal ground
FG	Frame ground connected to the chassis.

Cable connector-compatible wiring

Item	Description
Wire diameter	Twisted wire: AWG28-16 (0.14-1.5mm ²)
Stripped wire length	7mm

509

ROBONET

- Slider Type
- Mini
- Standard
- Controllers Integrated
- Rod Type
- Mini
- Standard
- Controllers Integrated
- Table/Arm /Flat Type
- Mini
- Standard
- Gripper/ Rotary Type
- Linear Servo Type
- Cleanroom Type
- Splash-Proof
- Controllers
- PMEC /AMEC
- PSEP /ASEP
- ROBO NET
- ERC2
- PCON
- ACON
- SCON
- PSEL
- ASEL
- SSEL
- XSEL
- Pulse Motor
- Servo Motor (24V)
- Servo Motor (200V)
- Linear Servo Motor

Configuration unit (Controller unit)

RACON unit Controller for RCA2/RCA series



Controller unit that is used for RCA2/RCA actuator operation with ROBONET.

Model **RACON-①②-③**

* In Model ①, input a motor power output. (See the following table.)

- ② will need the code "HA" or "LA" specified when a high acceleration/deceleration or power saving actuator is to be used. (Otherwise, leave it blank.)
- ③ input "ABU" only when a simple absolute unit is used. (Otherwise, leave it blank.)

Model	Compatible actuators
RACON-2②-③	RCL-SA1L / SA4L / SM4L / RA1L
RACON-5②-③	RCL-SA2L / SA5L / SM5L / RA2L
RACON-10②-③	RCA2-SA3C / RN3N / RP3N / GS3N / GD3N / SD3N / TC3N / TW3N / TF3N / TA4 RCL-SA3L / SA6L / SM6L / RA3L
RACON-20②-③	RCA-SA4 / SS4 / SA5 / SS5 / RA4 -20 / RG 4 -20 / A4R / A5R RCACR-SA4C / SA5 RCAW-RA4 -20 RCA2-SA4 / SA5 / TA6
RACON-20S②-③	RCA-RA3 / RG 3 RCAW-RA3 RCA2-SA4 / TA5
RACON-30②-③	RCA-SA6 / SS6 / RA4 -30 / RG 4 -30 / A6R RCACR-SA6 RCAW-RA4 -30 RCA2-SA6C / TA7C

Specifications

Item	Specifications	Item	Specifications		
General Specifications	Power Supply	DC24V ±10%	Environment Requirements	Ambient op. temperature	0~50°C
	Power Supply Capacity	5.1A max. (depends on the actuator)		Ambient op. humidity	95% RH or below (non-condensing)
	Operable Actuators	RCA series		Ambient op. environment	No corrosive or flammable gases, oil mist, or dust.
	Positioning Points	768 points		Protection class	IP20
	Backup memory	EEPROM		Weight	200g
	Position Detection Method	Incremental encoder	Accessories	ROBONET connection board (model JB-1), Power connection board (model PP-1)	
	Solenoid brake force-release	Brake release switch			
	Motor Cable	Model: CB-ACS-MA			
	Encoder Cable	Model: CB-ACS-PA			

RPCON unit Controller for RCP3/RCP2 series



Controller unit that is used for RCP3/RCP2 actuator operation with ROBONET.

Model **RPCON-①-②-③**

* In Model ①, input a motor type. (See the following table.)

- ② input "ABU" only when a simple absolute unit is used. (Otherwise, leave it blank.)
- ③ should have the code "H" when an RCP3-SA4, SA5, SA6, or an RCP2(RCP2CR)-SA5 or SA6 is to be connected.

Model	Compatible actuators
RPCON-20P-②	RCP2-RA2C / GRSS / GRLS / GRS RCP3-SA2A / SA2B / RA2A / RA2B
RPCON-28P-②	RCP2-GRM / GR3LS / GR3SS / RTB / RTC / RTBL / RTCL RCP3-SA3C
RPCON-28SP-②	RCP2-RA3C / RGD3C
RPCON-35P-②-③	RCP3-SA4 / TA5
RPCON-42P-②③	RCP2-SA5 / SA6 / SS7 / BA6 / BA7 / RA4C / RG 4C / GR3LM / GR3SM RCP3-SA5 / SA6 / TA6 / TA7 RCP2CR-SA5C / SA6C / SS7C RCP2W-RA4C
RPCON-56P-②	RCP2-SA7 / SS8 / RA6C / RG 6C / RCP2CR-SA7C / SS8C RCP2W-RA6C

Specifications

Item	Specifications	Item	Specifications		
General Specifications	Power Supply	DC24V ±10%	Environment Requirements	Ambient op. temperature	0~50°C
	Power Supply Capacity	2A max.		Ambient op. humidity	95% RH or below (non-condensing)
	Operable Actuators	RCP2 series		Ambient op. environment	No corrosive or flammable gases, oil mist, or dust.
	Positioning Points	768 points		Protection class	IP20
	Backup memory	EEPROM		Weight	200g
	Position Detection Method	Incremental encoder	Accessories	ROBONET connection board (model JB-1), Power connection board (model PP-1)	
	Solenoid brake force-release	Brake release switch			
	Motor Cable	Model: CB-RCP2-MA			
	Encoder Cable	Model: CB-RCP2-PB			



ROBONET **510**

- Slider Type
- Mini
- Standard
- Controllers Integrated
- Rod Type
- Mini
- Standard
- Controllers Integrated
- Table/Arm /Flat Type
- Mini
- Standard
- Cripper/ Rotary Type
- Linear Servo Type
- Cleanroom Type
- Splash-Proof
- Controllers
- PMEC /AMEC
- PSEP /ASEP
- ROBO NET
- ERC2
- PCON
- ACON
- SCON
- PSEL
- ASEL
- SSEL
- XSEL
- Pulse Motor
- Servo Motor (24V)
- Servo Motor (200V)
- Linear Servo Motor

Simple absolute R unit



A data backup battery unit that can be attached to an RACON or RPCON controller to use an incremental actuator as an absolute type.

*1 One unit of the simple absolute R unit is required per RACON/RPCON unit.

Model **RABU** (for RACON and RPCON)

* When preparing a simple absolute R unit together with a controller unit (RACON/RPCON), write down "-ABU" to the end of the controller model, of which the simple absolute unit is installed.

Specifications		Item	Specifications				Item	Specifications	
General Specifications	Power Supply	DC24V ±10%					Environment Requirements	Ambient op. temperature	0~40°C
	Current consumption	300mA max.						Ambient op. humidity	95% RH or below (non-condensing)
	Battery used	Ni-MH battery, nickel-hydrogen cell battery						Ambient op. environment	No corrosive or flammable gases, oil mist, or dust.
	Charging time	Approx. 78 hours						Protection class	IP20
	Battery life	3 yrs						Weight	330g
	Maximum rpm for absolute data retention	800	400	200	100	Accessories		ROBONET connection board (model JB-1) simple absolute connection board (model JB-1) power connection board (model PP-1)	
	Absolute Data Retention Duration (h)	120	240	360	480				

Extension Unit



When too many ROBONET units are connected horizontally to fit into the controller board, use this unit to split them in the middle with a cable to create another row.

In addition, by attaching the extension unit to the end of the linked ROBONET units and using an external controller cable, you can operate a standalone controller SCON like any other ROBONET controller, over the network.

Model **REXT** (for RPCON and RACON)

Specifications		Item	Specifications
General Specifications	Power Supply	DC24V ±10%	
	Current consumption	100mA max.	
Environment Requirements	Ambient op. temperature	0~40°C	
	Ambient op. humidity	95% RH or below (non-condensing)	
	Ambient op. environment	No corrosive or flammable gases, oil mist, or dust.	
	Protection class	IP20	
	Weight	140g	
	Accessories	ROBONET connection board (model JB-1), Power connection board (model PP-1)	

(Note) The cable used is different depending on whether you are creating a new row of linked units, or connecting a standalone controller.

For more information, see the ROBONET extension unit on P505.

External dimensional drawing

External dimensions of Gateway R unit, RACON unit, RPCON unit, Simple Absolute R unit, and Extension unit are same.

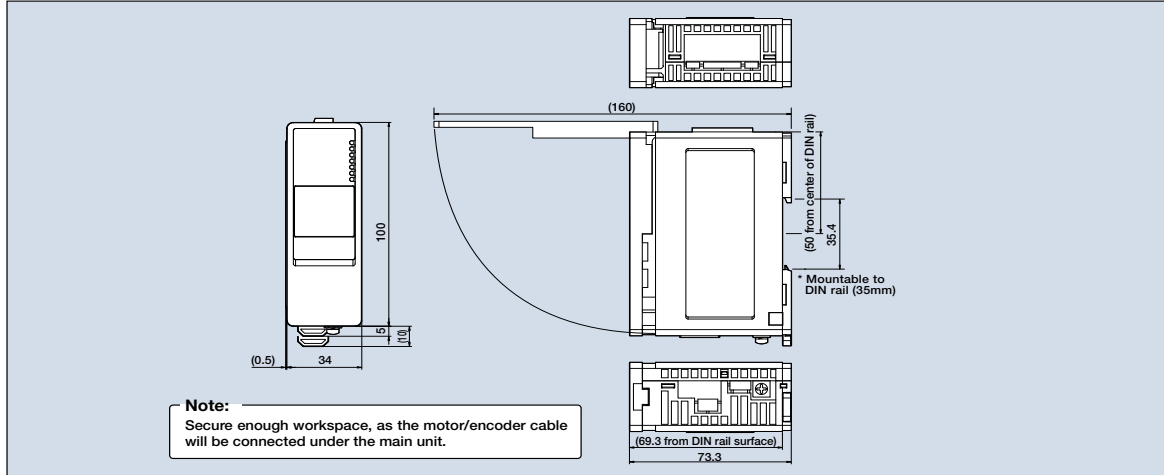

Option

Teaching Pendant

- Features A teaching device with functions for inputting positions, performing test runs, and monitoring.
- Model **CON-PT-M** (Touch panel teaching pendant)
CON-T (Standard type)
RCM-E (Simple teaching pendant)
- Configuration

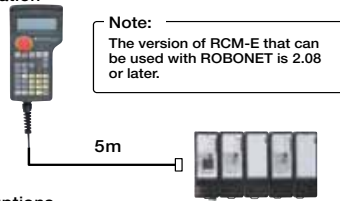

- CON-T Options
 - Wall-mounting hook Model HK-1
 - Strap Model STR-1

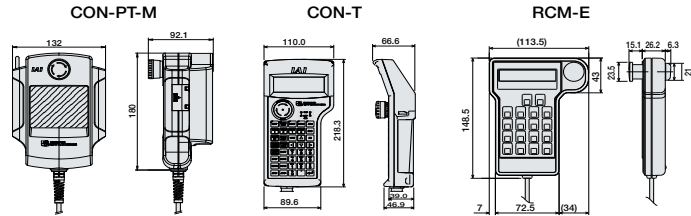

Specifications

Item	CON-PT-M	CON-T	RCM-E
Data Input	○	○	○
Actuator motion	○	○	○
Ambient Operating Temp./Humidity	Temp: 0~40°C; Humidity: 85% RH or below		
Ambient Operating Atmosphere	No corrosive gases. Especially no dust.		
Protection class	IP40	IP54	-
Weight	Approx. 750g	Approx. 400g	Approx. 400g
Cable Length	5m		
Display	3-color LED touch panel with backlight	20 char. x 4 lines LCD display	16 char. x 2 lines LCD display
Standard Price	-	-	-

PC Software (Windows Only)

- Features A startup support software for inputting positions, performing test runs, and monitoring. With enhancements for adjustment functions, the startup time is shortened.
- Model **RCM-101-MW** (with external device communications cable + RS232 conversion unit)

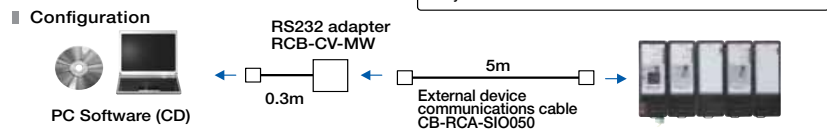

- Model **RCM-101-USB** (with external device communications cable + USB adapter + USB cable)

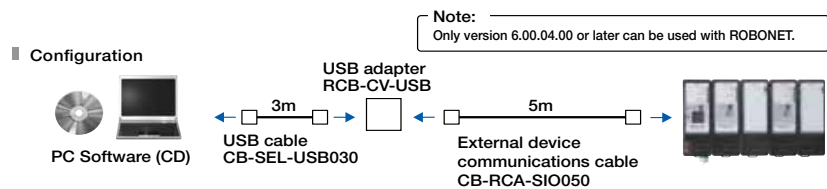

- Slider Type
- Mini
- Standard
- Controllers Integrated
- Rod Type
- Mini
- Standard
- Controllers Integrated
- Table/Arm /Flat Type
- Mini
- Standard
- Gripper/ Rotary Type
- Linear Servo Type
- Cleanroom Type
- Splash-Proof
- Controllers
- PMEC /AMEC
- PSEP /ASEP
- ROBO NET
- ERC2
- PCON
- ACON
- SCON
- PSEL
- ASEL
- SSEL
- XSEL
- Pulse Motor
- Servo Motor (24V)
- Servo Motor (200V)
- Linear Servo Motor

Option

DC24V Power Supply

Features

A 24V power supply for ROBO Cylinder that can output 17A of momentary current. Power supply units can be operated in parallel, and up to 5 units can be added if a unit runs out of capacity.

Model

PS-241

(100V input model)

PS-242

(200V input model)

Actuator vs. Power Supply Current

Controller type	Actuator type	Power Supply Current [A]		No. of connectible units for each unit of PS-24	
		Rated (= Maximum)	2	Simultaneous servo ON for all axes*	No simultaneous servo ON for all axes*
R/PCON PCON	RCP2, all models (note)	Rated	1.3	8	8
	SA4, SA5 (20W)	Maximum	4.4	3	6
R/ACON ACON	SA6 (30W)	Rated	1.3	4	6
		Maximum	4		
	RA3 (20W)	Rated	1.7	3	5
		Maximum	5.1		
	RA4 (20W)	Rated	1.3	3	6
		Maximum	4.4		
RA4 (30W)	Rated	1.3	4	6	
	Maximum	4			

* Refers to the first servo ON after power-up.
(Note) Excluding HS8C, HS8R, and RA10C
* For PSEL/ASEL, this is different depending on the number of axes and model.
Please inquire for details.



Spare parts

When spare parts are necessary after purchasing the product, such as when replacing a cable, refer to a list of the models below.



ROBONET connection board (simple absolute connection board) Model JB-1



Terminal resistor board Model TN-1



Power connection board Model PP-1

Motor cable for RCP2

Model **CB-RCP2-MA**

* The standard cable for the motor cable is the robot cable. Selection is available.
* Enter the cable length (L) into . Compatible to maximum of 20 meters. Ex.: 080 = 8m

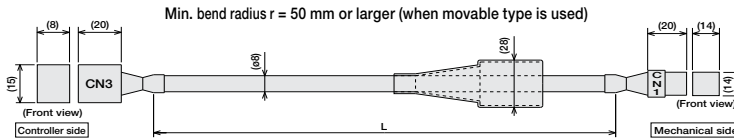

CN3		M cable		CN1		
Orange	A	A1	1	A	Yellow	SLP-06V (JST)
Gray	VMM	A2	2	VMM	Gray	
White	B	A3	3	A	Orange	
Pink	VMM	B2	4	B	Yellow (Green)	
Yellow (Green)	B	B3	5	VMM	Pink	
			6	B	White	

Encoder Cable/Encoder Robot Cable for RCP2

Model **CB-RCP2-PB** / **CB-RCP2-PB** -**RB**

* The standard encoder cable is the normal cable. The robot cable is selectable as an option.
* Enter the cable length (L) into . Compatible to maximum of 20 meters. Ex.: 080 = 8m

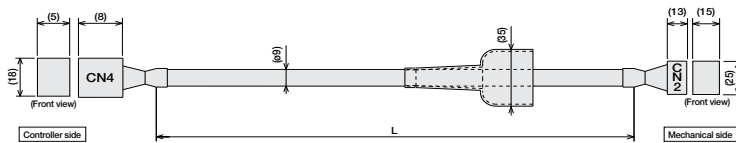

* Only the robot cable is to be used in a cable track.

Signal	Pin Number	Wire color	Pin Number	Signal
VMM	A1	Black	A1	VMM
A	A2	White	A2	A
B	B1	Red	B1	B
VMM	B2	Green	B2	VMM
B	B3	Yellow	B3	B
B	B3	Brown	B3	B
BK+	14	Pink (Red ●)	A4	NC
BK-	14	Pink (Blue ●)	A5	BK+
LS+	16	White (Red ●)	A6	BK-
LS-	16	White (Blue ●)	A6	LS+
A+	12	Orange (Red ●)	A7	LS-
A-	11	Orange (Blue ●)	A7	A+
S+	10	Gray (Red ●)	A8	A-
S-	9	Gray (Blue ●)	A8	S+
NC	8		A9	S-
VPS	7	Orange (Blue ●) Consecutive	A9	NC
VCC	6	Gray (Red ●) Consecutive	A10	VPS
GND	5	Gray (Blue ●) Consecutive	A10	VCC
NC	4		A11	GND
FG	1	Shield	B11	NC

Motor-encoder integrated type cable for RCP3/RCP2 (Limited to RCP2-GRSS/GRLS/GRST/SRA4R/SRGS4R/SRGD4R types)

Model **CB-PCS-MPA**

* Enter the cable length (L) into . Compatible to a maximum of 20 meters. Ex.: 080 = 8 m

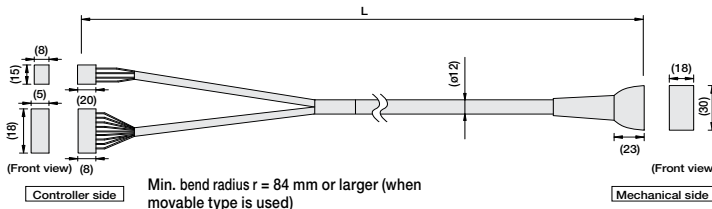

Signal	Pin Number	Wire color	Pin Number	Signal
VMM	A1	Black	A1	VMM
A	A2	White	A2	A
B	B1	Red	B1	B
VMM	B2	Green	B2	VMM
B	B3	Yellow	B3	B
B	B3	Brown	B3	B
BK+	14	Pink (Red ●)	A4	NC
BK-	14	Pink (Blue ●)	A5	BK+
LS+	16	White (Red ●)	A6	BK-
LS-	16	White (Blue ●)	A6	LS+
A+	12	Orange (Red ●)	A7	LS-
A-	11	Orange (Blue ●)	A7	A+
S+	10	Gray (Red ●)	A8	A-
S-	9	Gray (Blue ●)	A8	S+
NC	8		A9	S-
VPS	7	Orange (Blue ●) Consecutive	A9	NC
VCC	6	Gray (Red ●) Consecutive	A10	VPS
GND	5	Gray (Blue ●) Consecutive	A10	VCC
NC	4		A11	GND
FG	1	Shield	B11	NC

513

ROBONET

Spare parts

Motor Cable for RCA

Model **CB-ACS-MA**

* Enter the cable length (L) into . Compatible to a maximum of 20 meters.
Ex.: 080 = 8 m

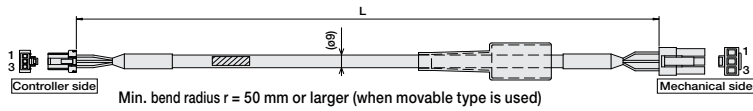

Wire	Color	Signal No.	U	No.	Signal	Color	Wire
AWG22 (crimped)	Red	U	1	1	U	Red	AWG22 (crimped)
	White	V	2	2	V	White	
	Black	W	3	3	W	Black	

Encoder Cable/Encoder Robot Cable for RCA

Model **CB-ACS-PA** / **CB-ACS-PA** -**RB**

* The standard encoder cable is the normal cable. The robot cable is selectable as an option.
* Enter the cable length (L) into . Compatible to maximum of 20 meters. Ex.: 080 = 8m

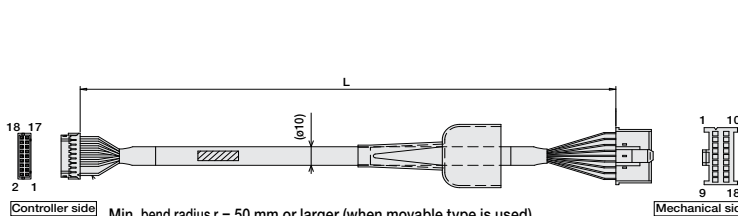

Cable color	Signal	Pin No.	Pin No.	Signal	Cable color
Robot Cable	Standard Cable	Signal	Pin No.	Pin No.	Signal
White/Purple	Blue	LS+	18	2	ENZ
White/Gray	Orange	LS-	17	3	ENB
Yellow	Green	SK+	16	4	ENB
Blue	Brown	BK-	15	5	-
White/Blue	Gray	ENA	14	6	-
White/Yellow	Red	ENZ	13	7	LS+
White/Red	Black	ENB	12	8	-
White/Black	Yellow	ENB	11	9	FG
Orange	Pink	ENZ	10	10	ENZ
Green	Purple	ENZ	9	11	White
Purple	White	-	8	12	White
Gray	Blue/Red	VPS	7	13	VPS
Red	Orange/White	SV	6	14	SV
Black	Green/White	COM2	5	15	COM2
-	-	-	4	16	LS-
-	-	-	3	17	BK-
-	-	-	2	18	BK+
Ground	Ground	F.G.	1	-	Yellow

Housing: PHDR-18V (JST)
Contact: SPHD-001P-0.5 (JST)

Pin housing: XMP-18V (JST)
Socket contact: BXA-001P-0.6 (JST)
Retainer: XMS-08V (JST)

Motor-Encoder Integrated Cable for RCA2

Model **CB-ACS-MPA**

* Enter the cable length (L) into . Compatible to a maximum of 20 meters.
Ex.: 080 = 8 m

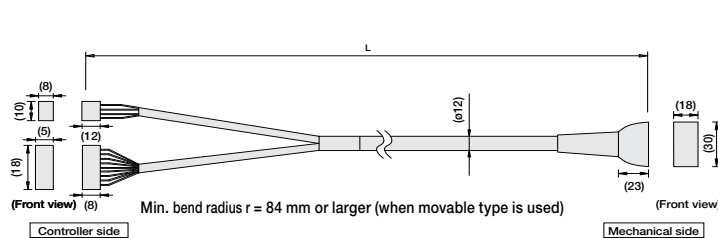

Signal	Pin No.	(Wire color)	Pin No.	Signal
U	1	Yellow	B1	V
V	2	Black	B2	W
W	3	Black	B3	NC
BK+	16	Yellow (Red ●)	A3	NC
BK-	15	Yellow (Blue ●)	B3	NC
LS+	18	Pink (Red ●)	A4	BK+
LS-	17	Pink (Blue ●)	B4	BK-
A+	14	White (Red ●)	A5	LS+
A-	13	White (Blue ●)	B5	LS-
B+	12	Orange (Red ●)	A7	B+
B-	11	Orange (Blue ●)	B7	B-
Z+	10	Gray (Red ●)	A8	Z+
Z-	9	Gray (Blue ●)	B8	Z-
-	8	Orange (Red ● Consecutive)	A9	-
/PS	7	Orange (Blue ● Consecutive)	B9	/PS
VCC	6	Gray (Red ● Consecutive)	A10	VCC
GND	5	Gray (Blue ● Consecutive)	B10	GND
NC	-	-	A11	NC
FG	1	-	B11	FG

Unit Link Cable for Extension Unit

Model **CB-REXT-SIO010**

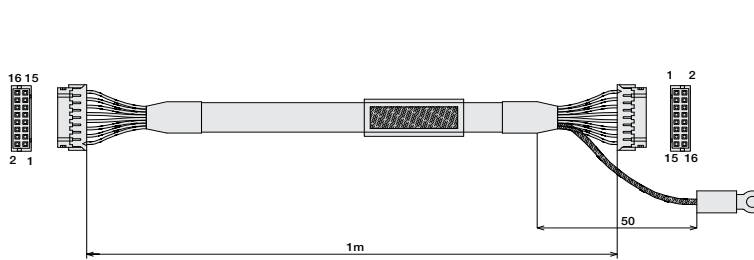

Signal	Pin No.	Signal	Pin No.
/RSV1	16	/RSV1	16
RSV1	15	RSV1	15
/ROUT	14	/ROUT	14
ROUT	13	ROUT	13
/RSV0	12	/RSV0	12
RSV0	11	RSV0	11
/ENA	10	/ENA	10
ENA	9	ENA	9
COM2	8	COM2	8
COM1	7	COM1	7
SD-	6	SD-	6
SD+	5	SD+	5
RD-	4	RD-	4
RD+	3	RD+	3
EMG-	2	EMG-	2
EMG+	1	EMG+	1

Ground: RAV1.25-3
- FG

Wire color legend: <Color of dot>-<Number>-<Color of insulation>

Controller Connection Cable for Extension Unit

Model **CB-REXT-CTL010**

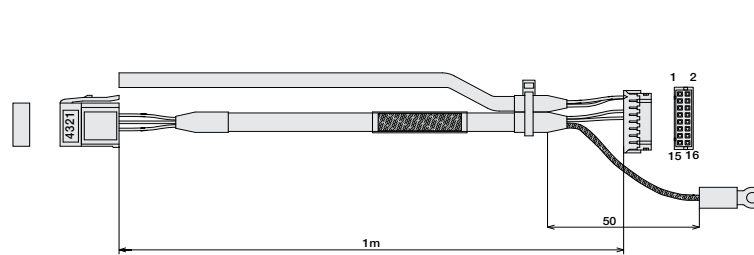

Pin No.	Signal	Pin No.	Signal
4	N.C.	9	ENA
3	GND	8	COM2
2	SD-	7	COM1
1	SD+	6	SD-
		5	SD+
		4	RD-
		3	RD+
		2	EMG-
		1	EMG+

Ground: RAV1.25-3
- FG

IAI

ROBONET **514**

- Slider Type
- Mini
- Standard
- Controllers Integrated
- Rod Type
- Mini
- Standard
- Controllers Integrated
- Table/Arm /Flat Type
- Mini
- Standard
- Gripper/ Rotary Type
- Linear Servo Type
- Cleanroom Type
- Splash-Proof
- Controllers
- PMEC /AMEC
- PSEP /ASEP
- ROBO NET
- ERC2
- PC0N
- ACON
- SCON
- PSEL
- ASEL
- SSEL
- XSEL
- Pulse Motor
- Servo Motor (24V)
- Servo Motor (200V)
- Linear Servo Motor

- Slider Type
- Mini
- Standard
- Controllers Integrated
- Rod Type
- Mini
- Standard
- Controllers Integrated
- Table/Arm /FlatType
- Mini
- Standard
- Gripper/ Rotary Type
- Linear Servo Type
- Cleanroom Type
- Splash-Proof
- Controllers
- PMEC /AMEC
- PSEP /ASEP
- ROBO NET
- ERC2
- PCON
- ACON
- SCON
- PSEL
- ASEL
- SSEL
- XSEL
- Pulse Motor
- Servo Motor (24V)
- Servo Motor (200V)
- Linear Servo Motor

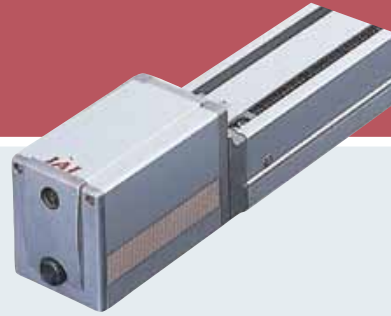

ERC2



■ Model: NP / PN / SE

Controller module of controller-integrated actuator

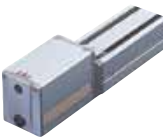
List of Models

I/O type	NP	PN	SE
Name	PIO type (NPN Specification)	PIO type (PNP Specification)	Serial Communication Type
External View			
Description	Controller that moves by designating position numbers with NPN PIO via PLC.	Controller that moves by designating position numbers with PNP PIO via PLC.	Controller that is used by connecting to the field network via the gateway unit.
Position points	16 points	16 points	64 points

Model

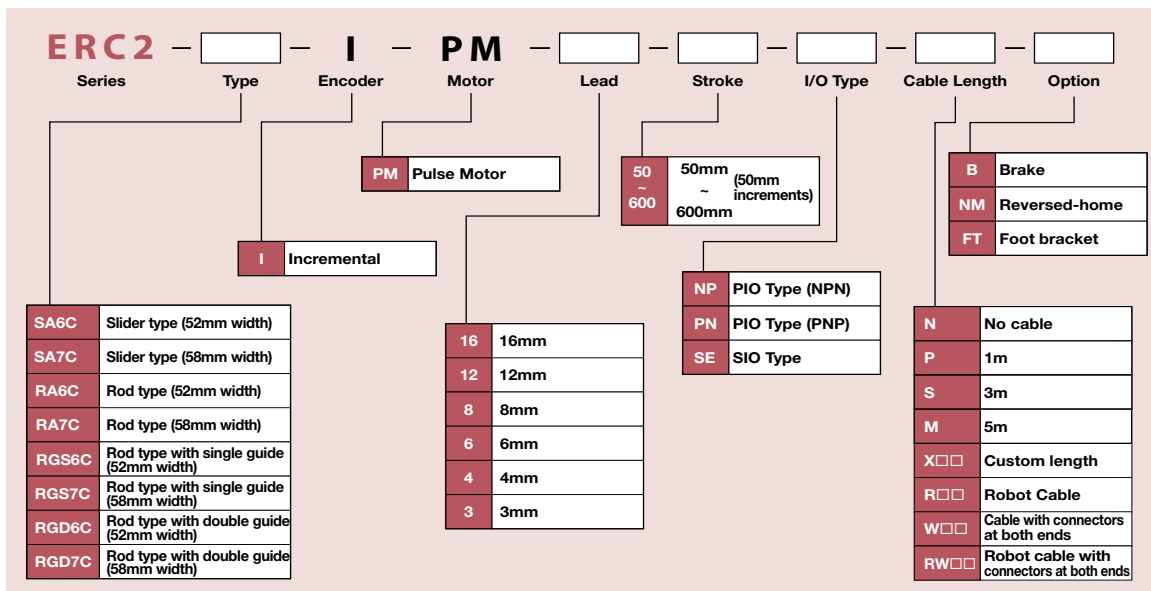

515 ERC2

System configuration

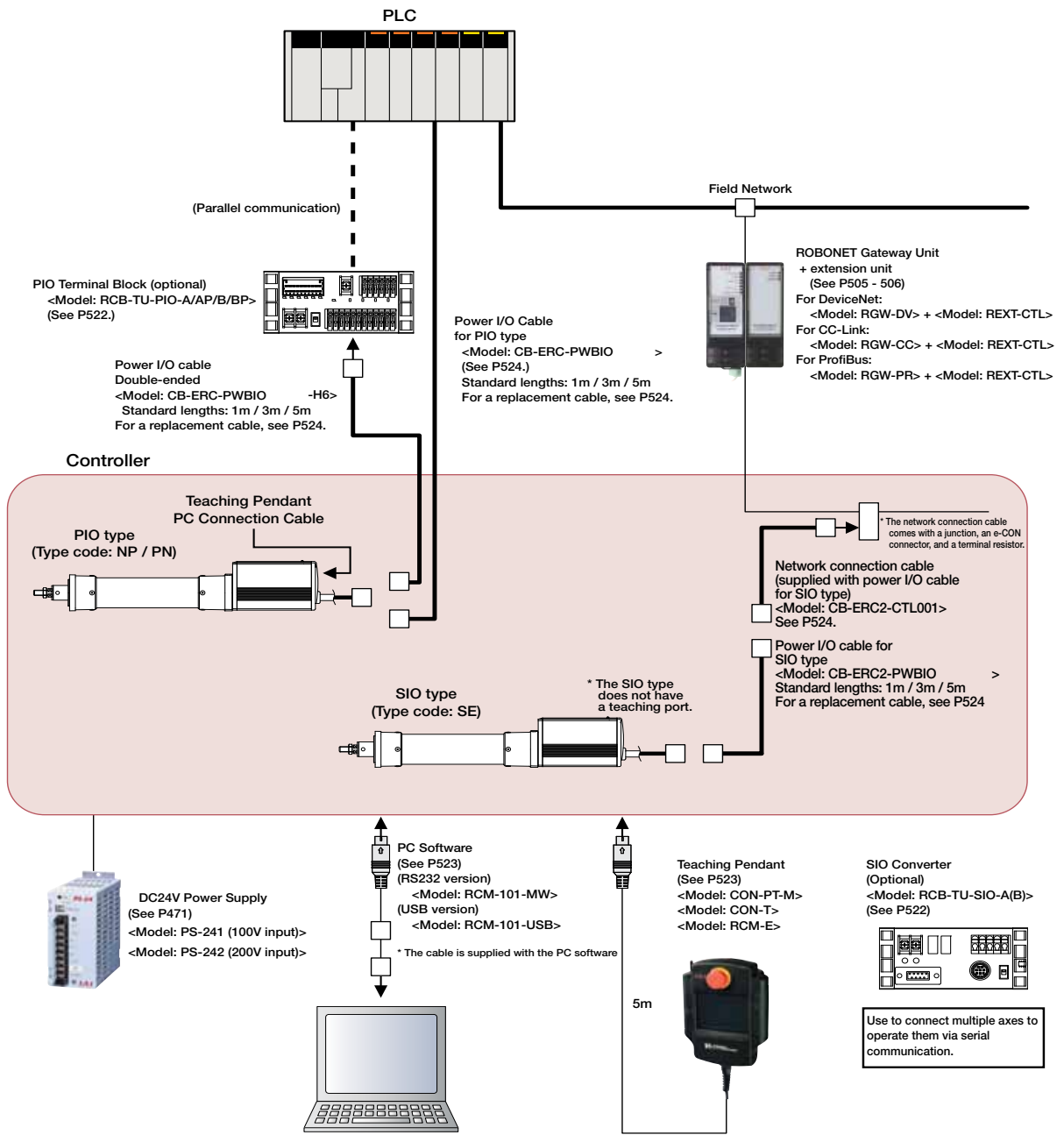

Wiring Diagram to Connect to a PC

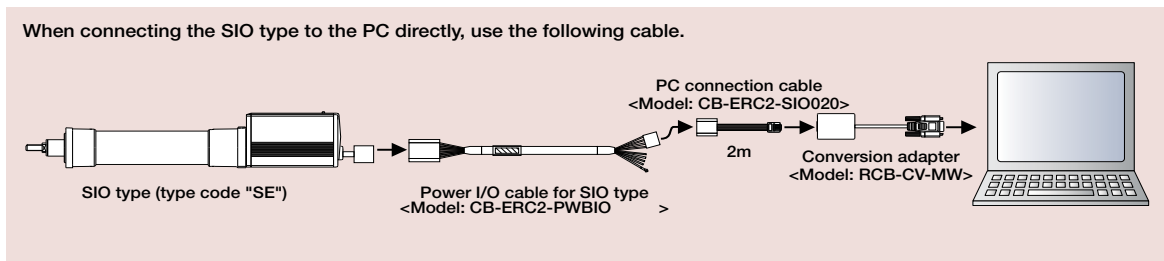

- Slider Type
- Mini
- Standard
- Controllers Integrated
- Pcd Type
- Mini
- Standard
- Controllers Integrated
- Table/Arm /FlatType
- Mini
- Standard
- Gripper/ Rotary Type
- Linear Servo Type
- Cleanroom Type
- Splash-Proof
- Controllers
- PMEC /AMEC
- PSEP /ASEP
- ROBO NET
- ERC2
- PCON
- ACON
- SCON
- PSEL
- ASEL
- SSEL
- XSEL

- Pulse Motor
- Servo Motor (24V)
- Servo Motor (200V)
- Linear Servo Motor

I/O specification (PIO type)

Input section External input specifications

Item	Specifications
Input points	6 points
Input voltage	DC24V +/-10%
Input current	4mA/circuit
Leak current	Max. 1mA/point
Operating voltage	ON voltage: Min. 18V (3.5mA) OFF voltage: Max. 6V (1mA)

NPN Specifications

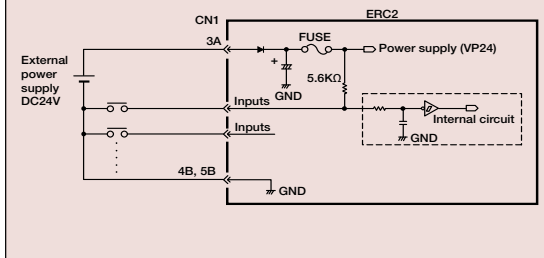

PNP Specifications

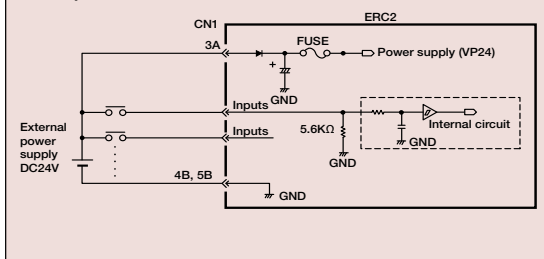

Output section External output specifications

Item	Specifications
Input points	4 points
Nominal load voltage	DC24V
Max. current	60mA/point
Remaining voltage	2V or less
Short-circuit, reverse voltage, protection	Fuse resistance (27Ω.0.1W)

NPN Specifications

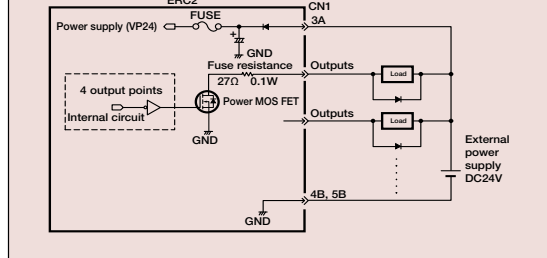

PNP Specifications

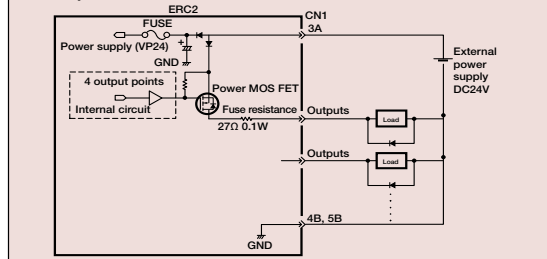

Table of I/O signals (PIO type)

Parameter (PIO pattern select)	PIO pattern	Pin No.
0	8-point type	A standard specification providing eight positioning points, plus a home return signal, zone signal, etc. (The parameter has been set to this pattern prior to the shipment.)
1	3-point type (Solenoid valve type)	Simply turn ON three signals of ST0 to ST2 to move the actuator to the corresponding positions (0 to 2), just like you do with solenoid valves (This allows for easy conversion from air cylinders).
2	16-point type (Zone signal type)	Can be positioned for up to 16 points. (Same as the 8-point type, except that this pattern provides no home return signal.)
3	16-point type (Position zone signal type)	A 16-point pattern with a position zone signal instead of a zone signal.

Pin No.	Classification	Wire color	Parameters (select PIO pattern)			
			0 Conventional type	1 3-point type (Solenoid valve type)	2 16-point type (Zone signal type)	3 16-point type (Position zone signal type)
1A	SIO	Orange (Red 1)	SGA			
1B		Orange (Black 1)	SGB			
2A	Signal	Light Blue (Red 1)	EMS1			
2B	Signal	Light Blue (Black 1)	EMS2			
3A	24V	White (Red 1)	24V			
3B	0V	White (Black 1)	BLK			
4A	24V	Yellow (Red 1)	MPI			
4B	0V	Yellow (Black 1)	GND			
5A	24V	Pink (Red 1)	MPI			
5B	0V	Pink (Black 1)	GND			
6A	Input	Orange (Red 2)	PC1	ST0	PC1	PC1
6B		Orange (Black 2)	PC2	ST1	PC2	PC2
7A		Light Blue (Red 2)	PC4	ST2	PC4	PC4
7B		Light Blue (Black 2)	HOME	-	PC8	PC8
8A		White (Red 2)	CSTR	RES	CSTR	CSTR
8B		White (Black 2)	* STP	* STP	* STP	* STP
9A		Yellow (Red 2)	PEND	PE0	PEND	PEND
9B		Yellow (Black 2)	HEND	PE1	HEND	HEND
10A	Output	Pink (Red 2)	ZONE	PE2	ZONE	PZONE
10B		Pink (Black 2)	* ALM			

Signals marked with an asterisk (*) (ALM/STP) are negative logic signals so they are normally on.

517

ERC2

Signal names

Classification	Signal Name	Signal abbreviations	Function overview
SIO	Serial Communication	SGA SGB	Used for serial communication.
	Emergency stop	EMS1 EMS2	These signals are wired to enable the emergency stop switch on the teaching pendant (see P521).
24V 0V	Brake release	BKR	By connecting to 0V (150mA needed) the brake is forcibly released.
Input	Command position No.	PC1 PC2 PC4 PC8	Designates the position number using 4-bit binary signals (or 3-bit binary signals if the 8-point PIO pattern is selected). (Example) Position 3 → Input PC1 and PC2 Position 7 → Input PC1 and PC2 and PC4
	Position movement	ST0 ST1 ST2	Turn the ST0 signal on to move the actuator to position 0. Same for ST1 and ST2 (Operation can be started with these signals alone. No need to input a start signal).
	Home return	HOME	Home-return operation starts at the leading edge of this signal.
	Start	CSTR	Input a command position number signal and turn this signal ON, and the actuator will start moving to the specified position.
	Reset	RES	Turning this signal ON resets the alarms that are present. When it is paused (*STP is off), it is possible to cancel the residual movement.
	Pause	* STP	Normal operation is allowed while this signal is ON (negative logic) The actuator starts to decelerate to a stop at the ON → OFF leading edge of this signal.
	Output	Positioning complete	PEND
Complete position No.		PE0 PE1 PE2	PE0 is output upon completion of movement to position 0. Same for PE1 and PE2. (These signals are valid only when the 3-point PIO pattern is selected.)
Home return complete		HEND	This signal turns ON upon completion of home return.
Zone		ZONE	This signal turns ON upon entry into the zone signal range set by parameters.
Position zone		PZONE	This signal turns ON upon entry into the zone signal range set in the position table.
Alarm		* ALM	The signal remains ON in normal conditions and turns OFF upon generation of the alarm (negative logic). Synchronized with the LED at the top of the motor cover (green: normal state, red: alarm on).

Signals marked with an asterisk (*) (ALM/STP) are negative logic signals, so they are normally on.

Specification Table

Specification	Details	
	Type	SIO specification (SE)
Control method	Low field vector control (patent pending)	
Positioning command	Position No. designation	Position No. designation / Direct value designation
Position No.	Max. 16 points	Max. 64 points
Backup memory	Position number data and parameters are stored in nonvolatile memory. Serial EEPROM with a rewrite life of 100,000 times	
PIO	6 dedicated input points/4 dedicated output points	None
Electromagnetic brake	Built-in circuit DC24V±10% 0.15A max.	
2-color LED display	Servo ON (green), Alarm/motor drive power supply shut-down (red)	
I/O power (Note 1)	Common to control power (non-isolated)	
Serial Communication	RS485 1ch (External termination)	
Absolute function	None	
Forced release of electromagnetic brake	Forced release when connected to 0V (NP), or 24V (PN)	Forced release when connected to 24V
Cable Length	I/O cable: 10m max.	
	SIO connector communication cable: 5m or shorter	
Dielectric strength voltage	DC500V 10MΩ	
EMC	EN55011 Class A Group1 (3m)	
Power supply voltage	DC24V ± 10%	
Power supply current	2A max.	
Environment	Ambient operating temperature	0 ~ 40°C
	Ambient operating humidity	85% RH or lower (non-condensing)
	Ambient operating atmosphere	Free from corrosive gases
Protection class	IP20	

Use the isolated PIO terminal block (option P522) to isolate the I/O power supply.

- Slider Type
- Mini
- Standard
- Controllers Integrated
- Pod Type
- Mini
- Standard
- Controllers Integrated
- Table/Arm /FlatType
- Mini
- Standard
- Gripper/ Rotary Type
- Linear Servo Type
- Cleanroom Type
- Splash-Proof
- Controllers
- PMEC /AMEC
- PSEP /ASEP
- ROBO NET
- ERC2
- PCON
- ACON
- SCON
- PSEL
- ASEL
- SSEL
- XSEL
- Pulse Motor
- Servo Motor (24V)
- Servo Motor (200V)
- Linear Servo Motor

PIO Type NP (NPN Specification)

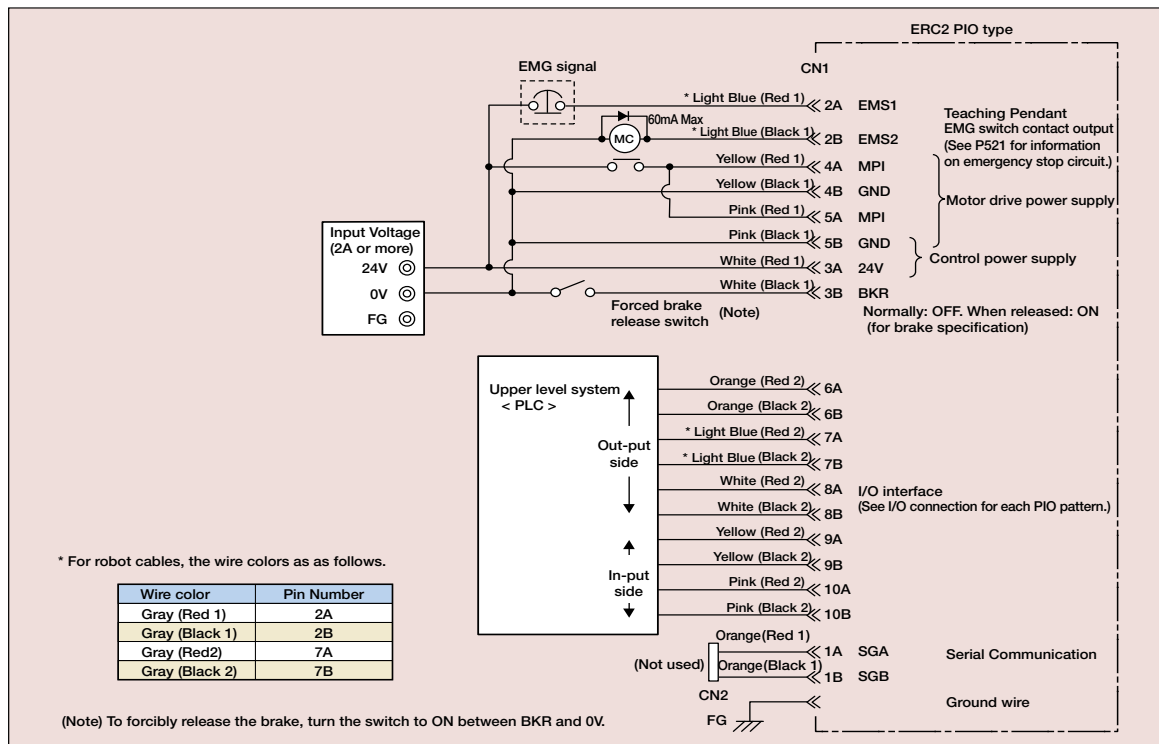

PIO Type PN (PNP Specification)

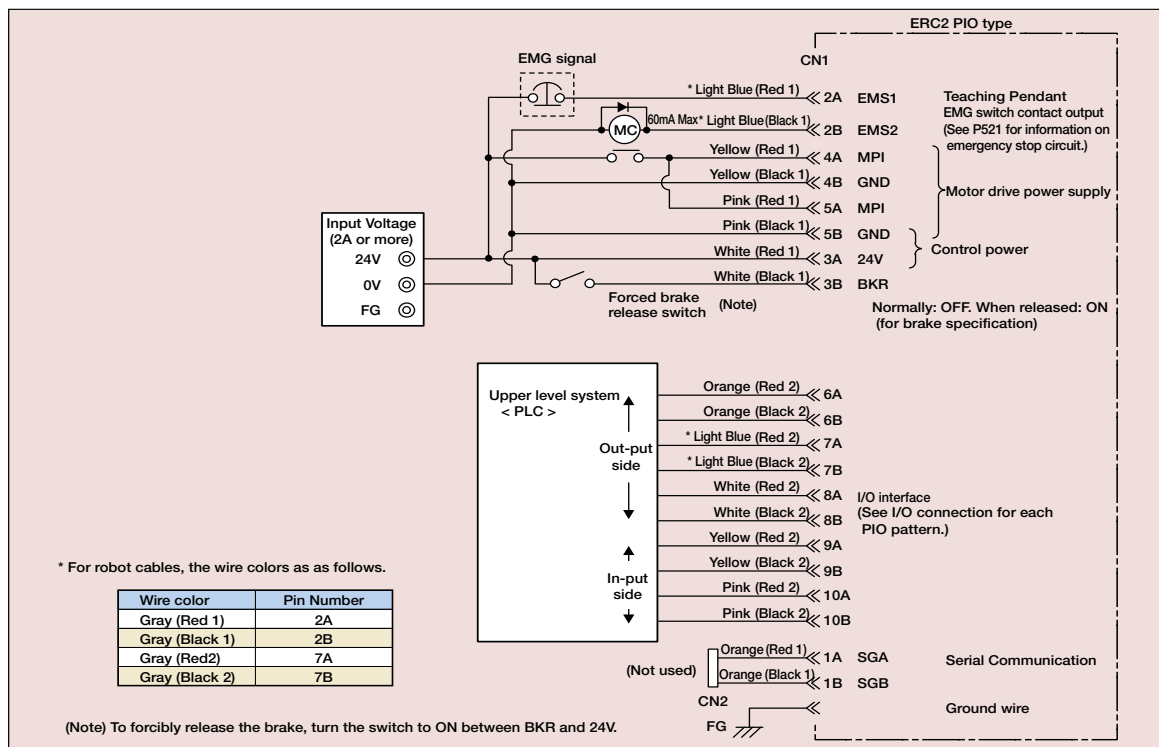

519

ERC2

SIO Type SE

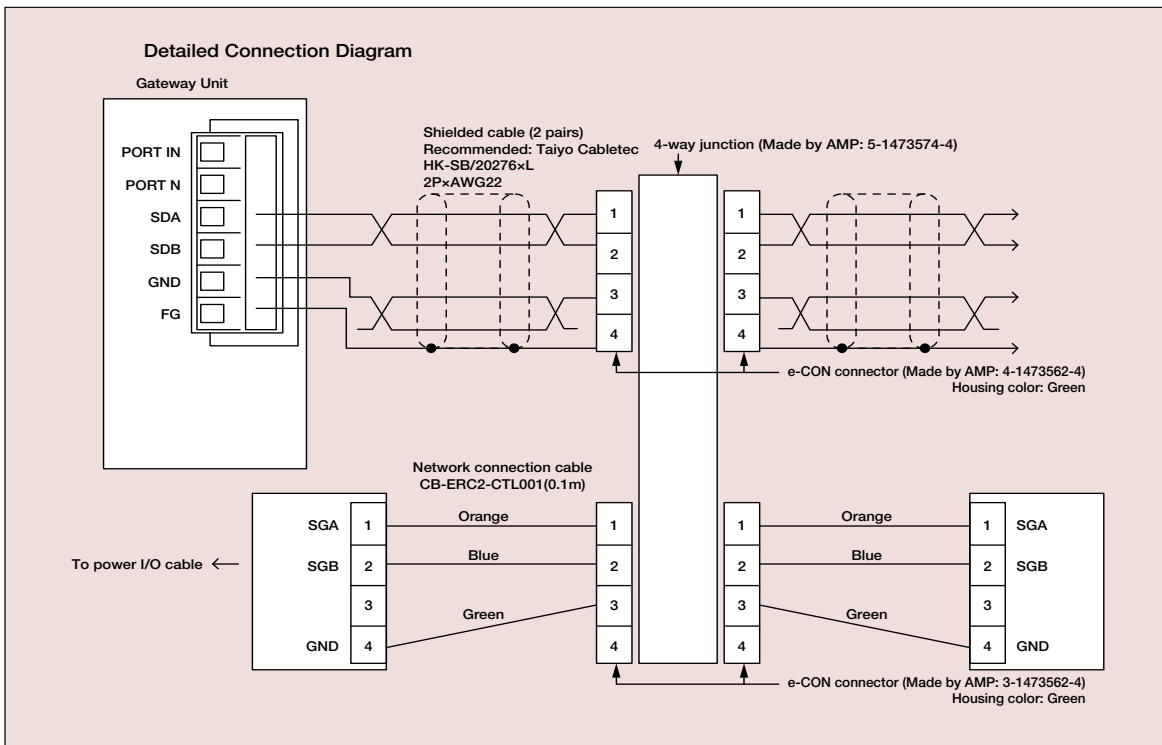
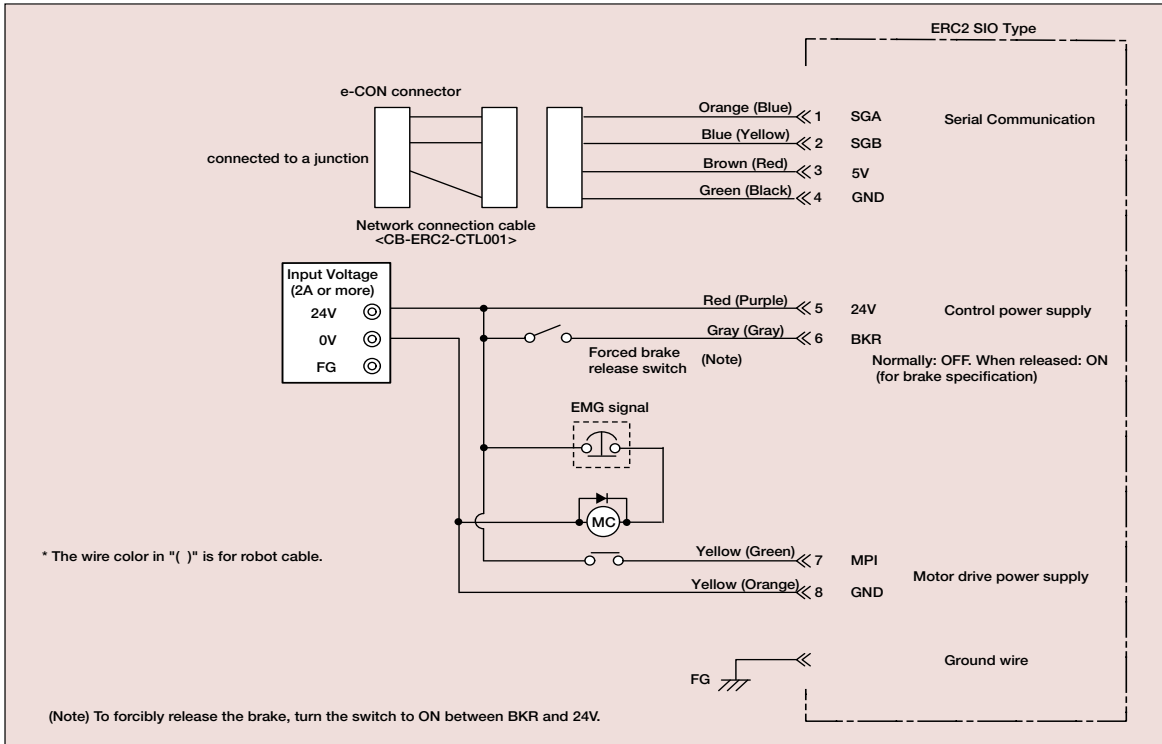

ERC2 **520**

- Slider Type
- Mini
- Standard
- Controllers Integrated
- Pcd Type
- Mini
- Standard
- Controllers Integrated
- Table/Arm /FlatType
- Mini
- Standard
- Gripper/ Rotary Type
- Linear Servo Type
- Cleanroom Type
- Splash-Proof
- Controllers
- PMEC /AMEC
- PSEP /ASEP
- ROBO NET
- ERC2
- PCON
- ACON
- SCON
- PSEL
- ASEL
- SSEL
- XSEL
- Pulse Motor
- Servo Motor (24V)
- Servo Motor (200V)
- Linear Servo Motor

Emergency Stop Circuit

The ERC2 series has no built-in emergency stop circuit, so the customer must provide an emergency stop circuit based on the logic explained below.

(The circuit below is simplified for explanation purposes. Provide a ready circuit, etc., according to your specification.)

Single Axis: To provide an emergency stop circuit for a single-axis configuration, operate a relay using the EMS1 and EMS2 contacts of the power & I/O cable to cut off MPI (motor power).

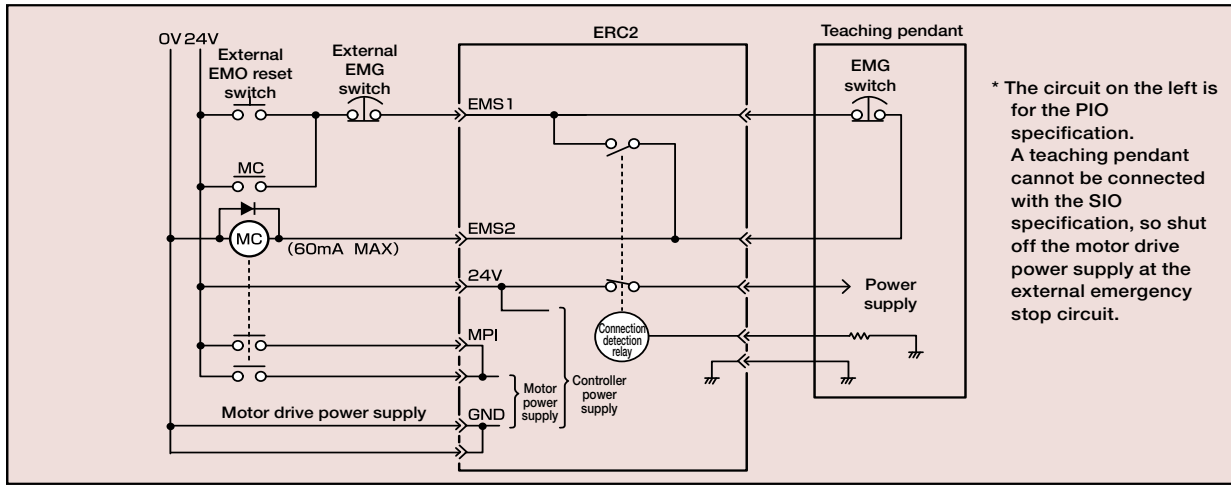

Multiple Axis: To provide an emergency stop circuit for a multiple-axes configuration, operate a relay using the EMG1 and EMG2 contacts of the SIO converter to cut off MPI (motor power) for each axis.

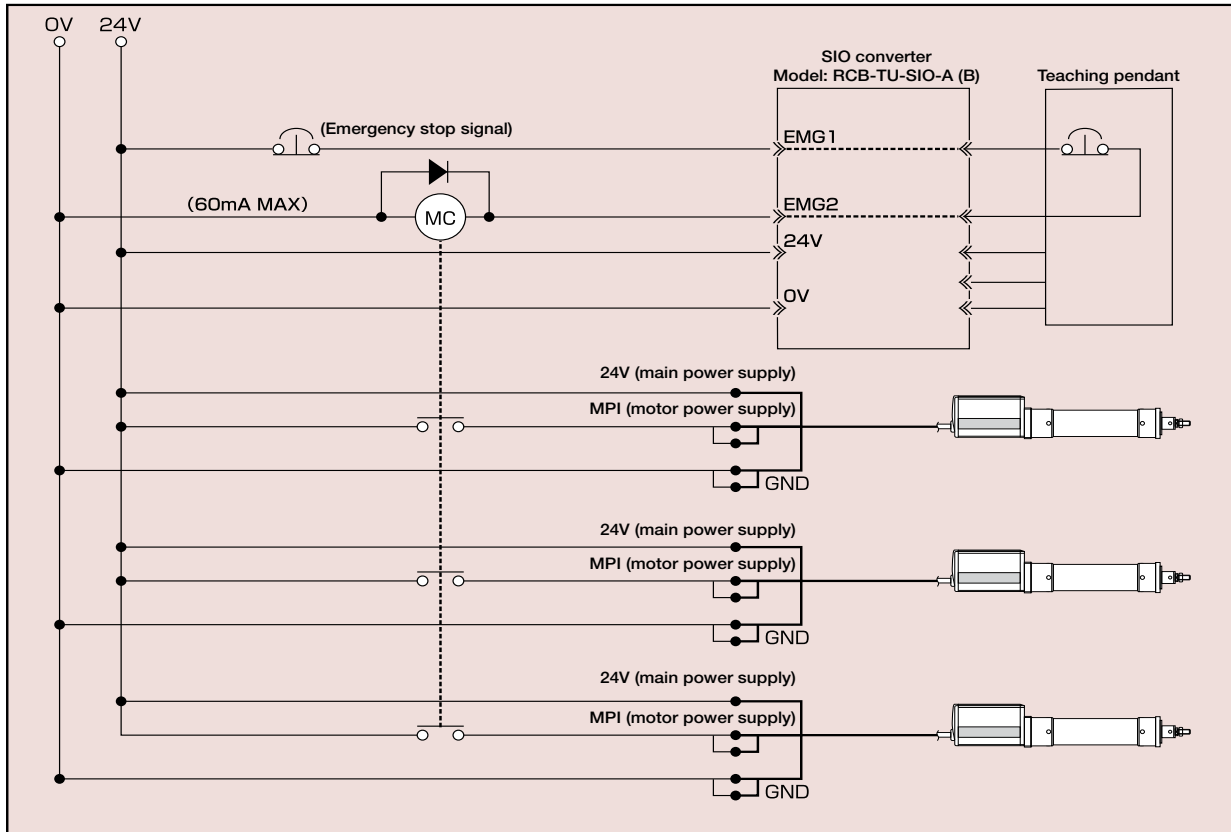

521 ERC2

- Slider Type
- Mini
- Standard
- Controllers Integrated
- Rod Type
- Mini
- Standard
- Controllers Integrated
- Table/Arm /FlatType
- Mini
- Standard
- Gripper/ Rotary Type
- Linear Servo Type
- Cleanroom Type
- Splash-Proof
- Controllers
- PMEC /AMEC
- PSEP /ASEP
- RDBO NET
- ERC2
- PCON
- ACON
- SCON
- PSEL
- ASEL
- SSEL
- XSEL
- Pulse Motor
- Servo Motor (24V)
- Servo Motor (200V)
- Linear Servo Motor

Option

Isolated PIO Terminal Block

This terminal block is used to isolate the I/O power or simplify the wiring with a PLC.
 *When a terminal block is used, the optional power & I/O cable with connectors on both ends must be used.

Features - The input and output ports are non-polar, so both NPN and PNP are compatible with the I/O specifications on the PLC side.
 - An input/output-signal monitor LED is equipped to check the ON/OFF status of signals.

Specifications	Item	Specifications
	Power supply voltage	DC24V±10%
	Ambient Operating Temp./Humidity	0 to 55°C, 85% RH or below (non-condensing)
Input area	Input points	6 points
	Input voltage	DC24V±10%
	Input current	7mA/circuit (bipolar)
	Allowable leaked current	1mA/point (at room temperature, about 2mA)
	Operating voltage (with respect to ground)	Input ON: Min. 16V (4.5mA) OFF : Max. 5V (1.3 mA)
Output area	Output points	4 points
	Rated load voltage	DC24V
	Max. current	60mA/point
	Residual voltage	2V or less/60mA
	Short circuit Overcurrent protection	Fuse resistance (27Ω0.1W)

Note:
 If you are using the ERC2-PN (PNP specification), use RCB-TU-PIO-AP/BP (compatible with PNP specification).

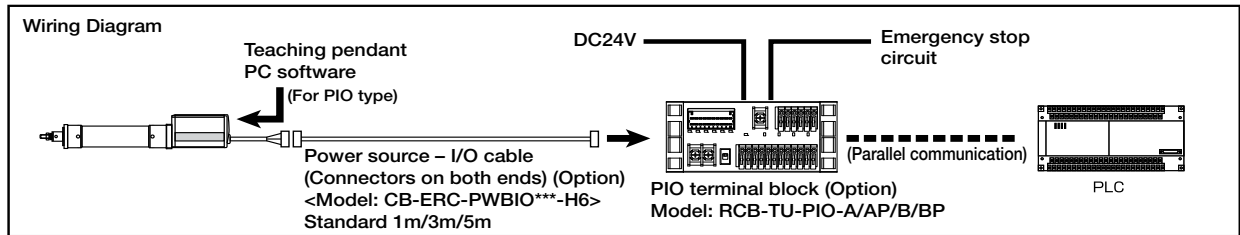
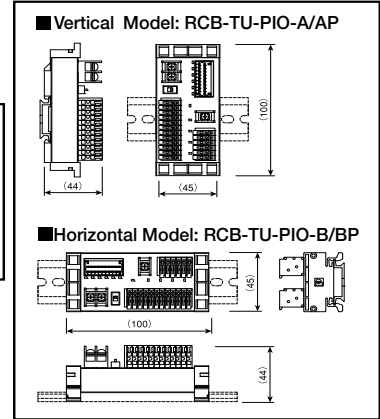

SIO Converter

This converter can be used for RS232 communication by connecting a serial communication wire (SGA, SGB) for the power-I/O cable, and using a D-sub 9-pin cross cable to connect a computer.

Features - The connection port for teaching-pendant or a PC cable can be installed at any position away from the actuator.
 - Multiple axes can be connected and operated from a PC via serial communication.

Specifications	Item	Specifications
	Power supply voltage	DC24V ±10%
	Ambient Operating Temp./Humidity	0 to 55°C, 85% RH or below (non-condensing)
	Terminal resistor	120Ω (built-in)

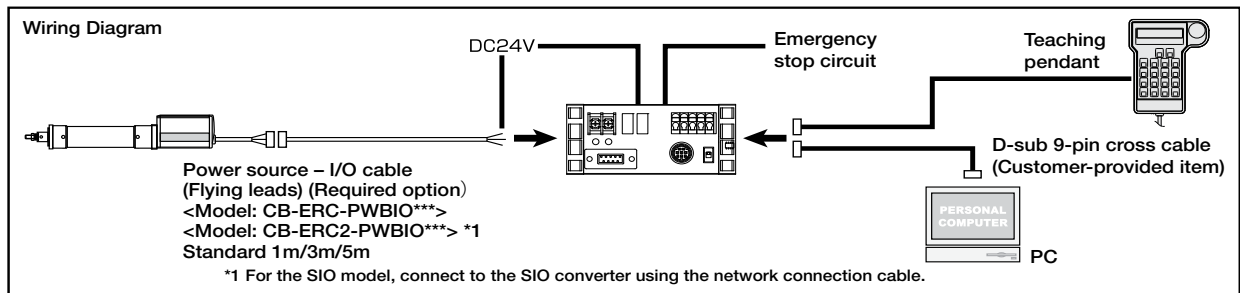
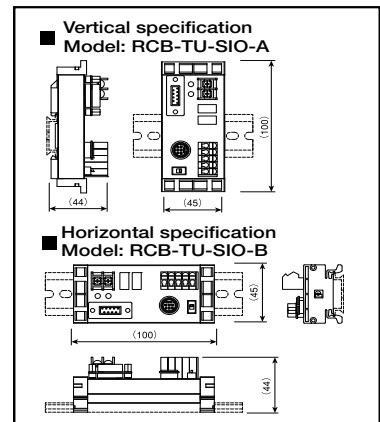

- Slider Type
- Mini
- Standard
- Controllers Integrated
- Pcd Type
- Mini
- Standard
- Controllers Integrated
- Table/Arm /FlatType
- Mini
- Standard
- Gripper/ Rotary Type
- Linear Servo Type
- Cleanroom Type
- Splash-Proo
- Controllers
- PMEC /AMEC
- PSEP /ASEP
- ROBO NET
- ERC2
- PCON
- ACON
- SCON
- PSEL
- ASEL
- SSEL
- XSEL
- Pulse Motor
- Servo Motor (24V)
- Servo Motor (200V)
- Linear Servo Motor

Option

Teaching Pendant

■ **Features** This is a teaching device that provides information on functions such as position input, test runs, and monitoring.

■ **Model** **CON-PT-M-ENG** (Touch panel teaching pendant)

CON-T-ENG (Standard type)

RCM-E-ENG (Simple teaching pendant)

■ **Configuration**

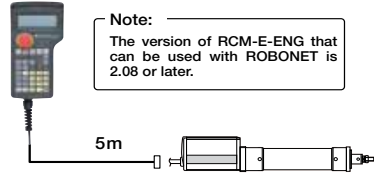

■ **CON-T-ENG Options**

- Wall-mounting hook Model HK-1
- Strap Model STR-1

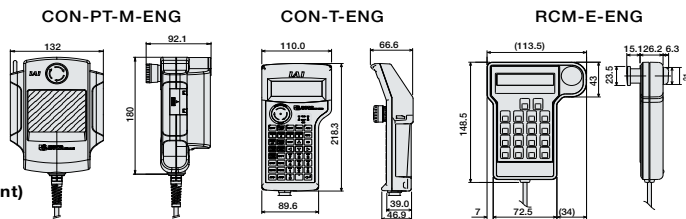

Specifications

Item	CON-PT-M-ENG	CON-T-ENG	RCM-E-ENG
Data Input	○	○	○
Actuator motion	○	○	○
Ambient Operating Temp./Humidity	Temp: 0~40°C; Humidity: 85% RH or below		
Ambient Operating Atmosphere	No corrosive gases. Especially no dust.		
Protection class	IP40	IP54	-
Weight	Approx. 750g	Approx. 400g	Approx. 400g
Cable Length	5m		
Display	3-color LED touch panel with backlight	20 char. x 4 lines LCD display	16 char. x 2 lines LCD display

PC Software (Windows Only)

■ **Features** A startup support software for teaching positions, performing test runs, and monitoring. With enhancements for adjustment functions, the startup time is shortened.

■ **Model** **RCM-101-MW** (External device communications cable + RS232 conversion unit)

■ **Configuration**



■ **Model** **RCM-101-USB** (External device communications cable + USB adapter + USB cable)

■ **Configuration**

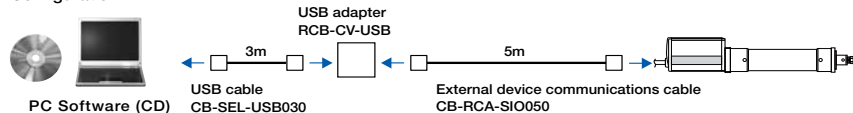

Cables & Spare Parts

Power & I/O Cable, Power & I/O Robot Cable For PIO

Model **CB-ERC-PWBIO** / **CB-ERC-PWBIO** -RB

* Enter the cable length (L) into . Compatible to a maximum of 10 meters. Ex.: 080 = 8 m

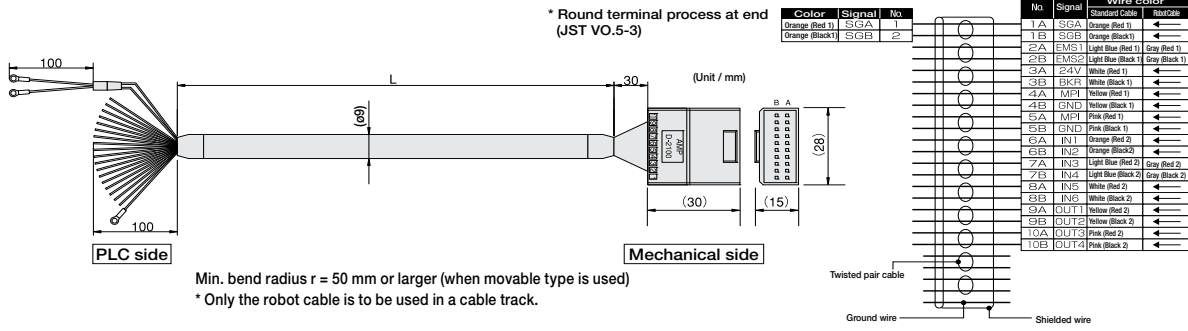

Power & I/O Cable, Power-I/O Robot Cable (Connectors on Both Ends)

Model **CB-ERC-PWBIO** -H6 / **CB-ERC-PWBIO** -RB-H6

* Enter the cable length (L) into . Compatible to a maximum of 10 meters. Ex.: 080 = 8 m

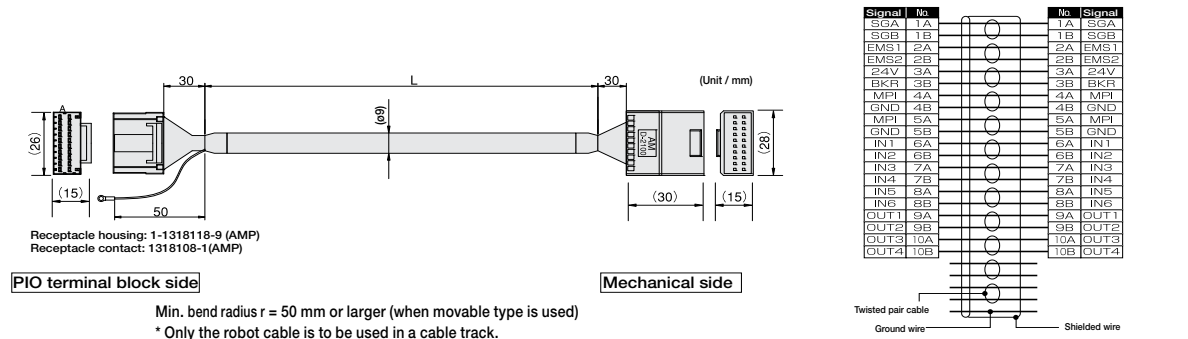

Power & I/O Cable, Power & I/O Robot Cable For SIO Type

Model **CB-ERC2-PWBIO** / **CB-ERC2-PWBIO** -RB

* Enter the cable length (L) into . Compatible to a maximum of 10 meters. Ex.: 080 = 8 m

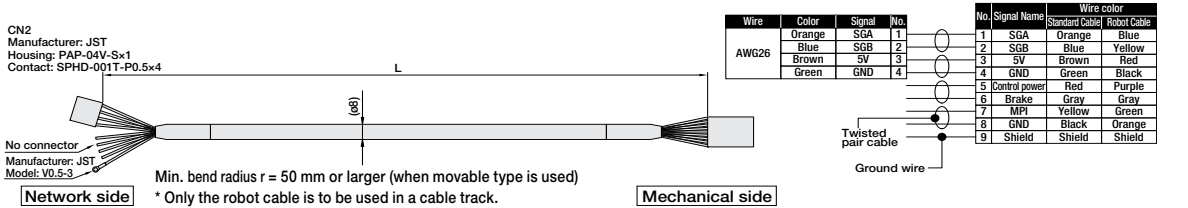

Network Connection Cable

Model **CB-ERC2-CTL001**

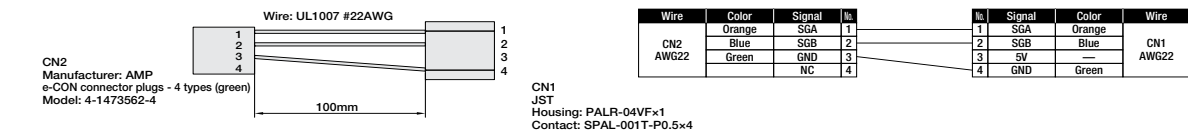

Communication Cable to Connect to PC

Model **CB-ERC2-SIO020**

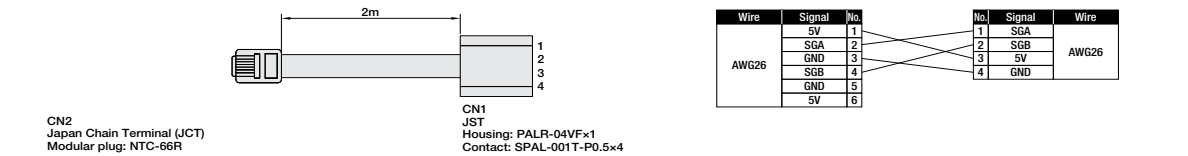

- Slider Type
- Mini
- Standard
- Controllers Integrated
- PCd Type
- Mini
- Standard
- Controllers Integrated
- Table/Arm /FlatType
- Mini
- Standard
- Gripper/ Rotary Type
- Linear Servo Type
- Cleanroom Type
- Splash-Proof
- Controllers
- PMEC /AMEC
- PSEP /ASEP
- ROBO NET
- ERC2
- PCON
- ACON
- SCON
- PSEL
- ASEL
- SSEL
- XSEL
- Pulse Motor
- Servo Motor (24V)
- Servo Motor (200V)
- Linear Servo Motor

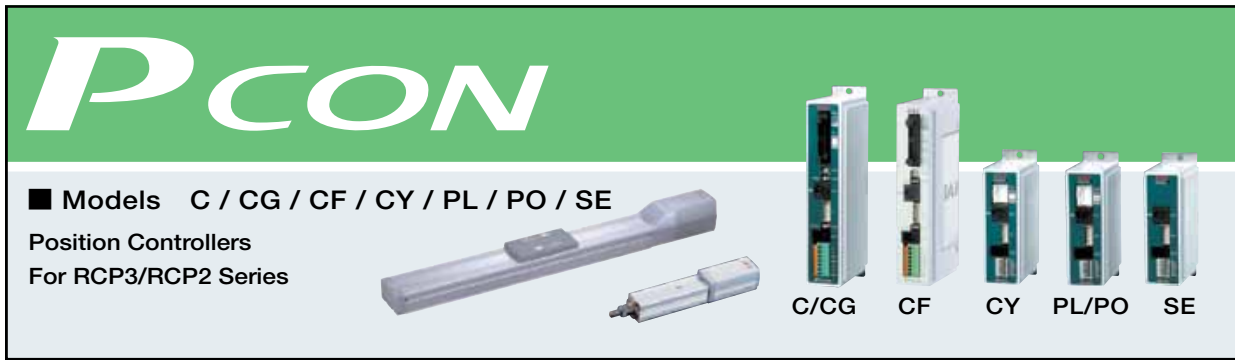

■ Models C / CG / CF / CY / PL / PO / SE

Position Controllers
For RCP3/RCP2 Series

C/CG CF CY PL/PO SE

List of models

These are the position controllers that can be used with the RCP3/RCP2 Series actuators. Our line-up has 6 types, which are compatible with various control systems.

Type	C	CG	CF	CY	PL/PO	SE
Name	Positioner type	Conforming to safety category compatible type	High-thrust motor compatible type	Solenoid valve type	Pulse train control type	Serial communication type
External View						
Description	Positioner capable of a maximum of 512 points Positioning	Conforming to type C safety category specifications	Dedicated controller for RCP2 high-speed type/high-thrust type / waterproof type	Can be operated using the same control as the air cylinder type	For pulse train control	For Serial communication
Position points	512 points	512 points	512 points	3 points	-	64 points

(*1) Network connection specifications are designated by the I/O type symbols for the model.

Model

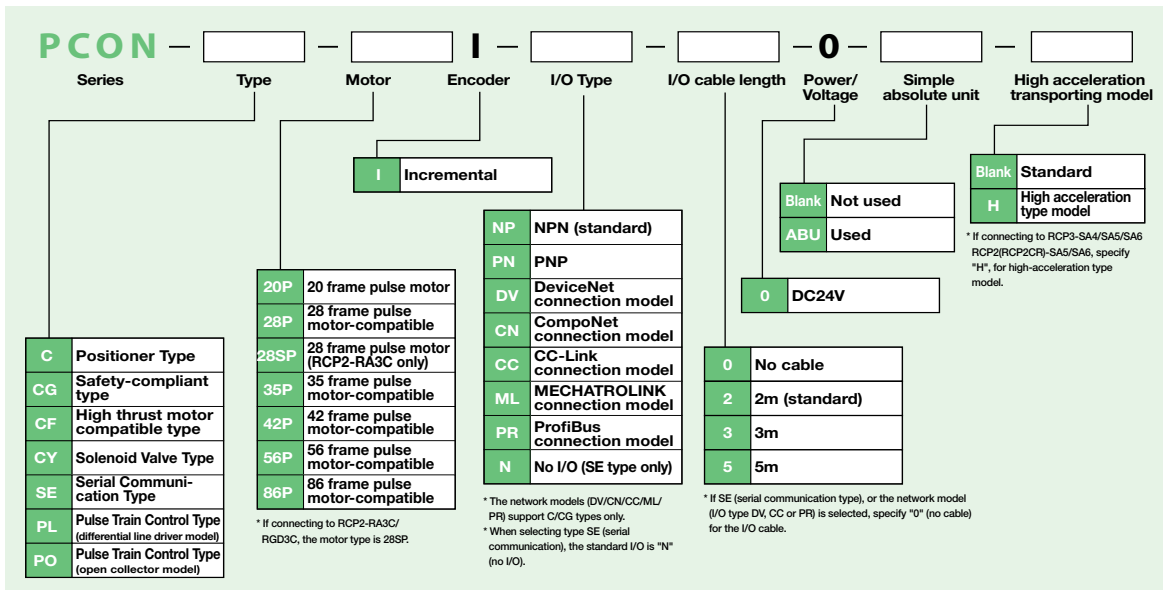

525 PCON

System configuration

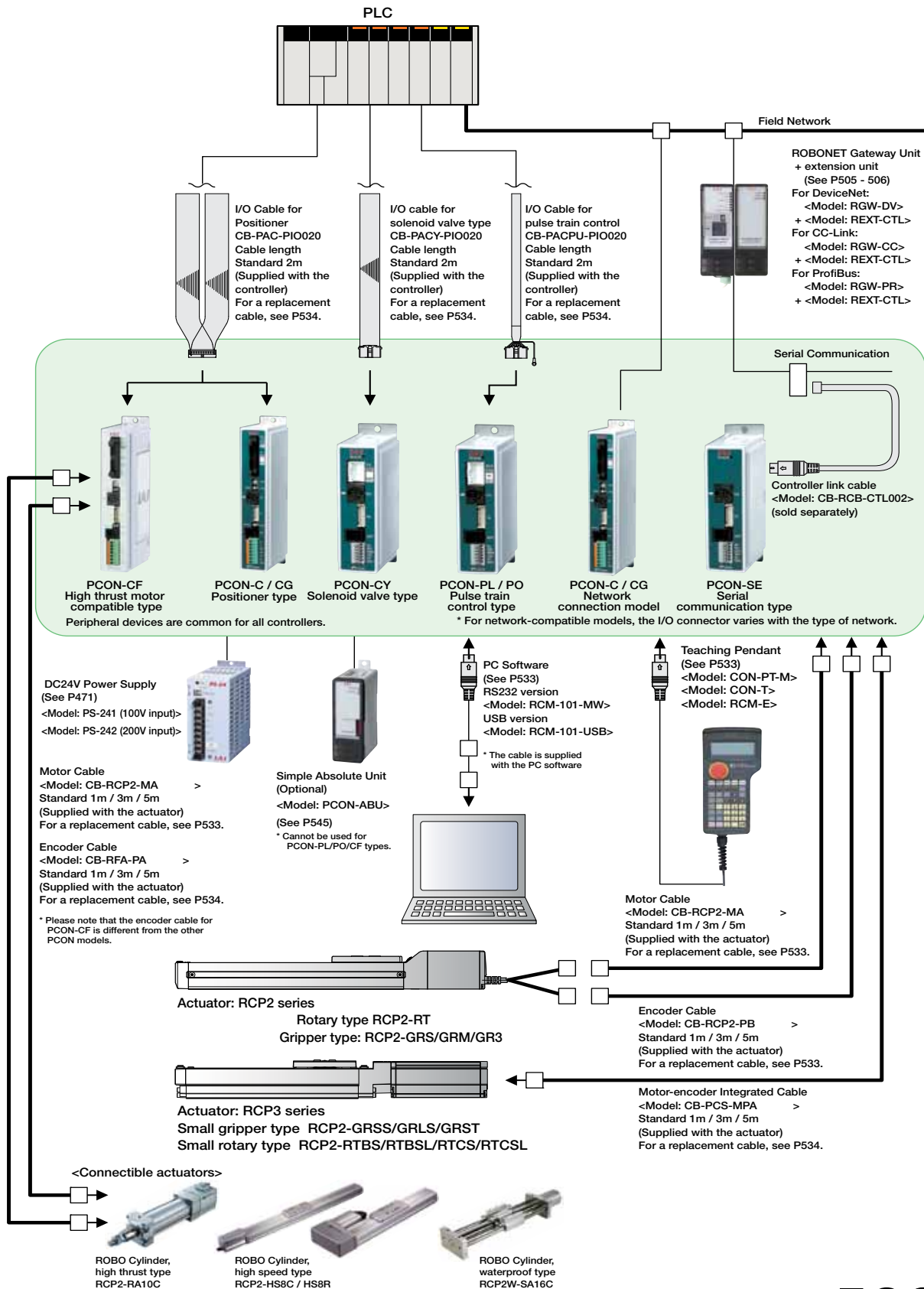

- Slider Type
- Mini
- Standard
- Controllers Integrated
- Pcd Type
- Mini
- Standard
- Controllers Integrated
- Table/Arm /FlatType
- Mini
- Standard
- Gripper/ Rotary Type
- Linear Servo Type
- Cleanroom Type
- Splash-Proo
- Controllers
- PMEC /AMEC
- PSEP /ASEP
- ROBO NET
- ERC2
- PCON
- ACON
- SCON
- PSEL
- ASEL
- SSEL
- XSEL
- Pulse Motor
- Servo Motor (24V)
- Servo Motor (200V)
- Linear Servo Motor

I/O Specifications

Input section External input specifications

Item	Specifications
Input voltage	DC24V +/-10%
Input current	4mA/circuit
Leak current	1mA max./point
Isolation method	Photocoupler

NPN Specifications

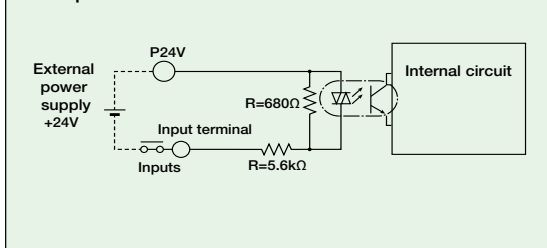

PNP Specifications

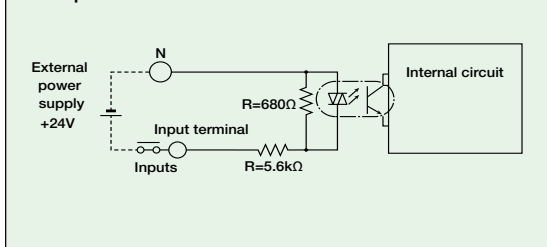

Output section External output specifications

Item	Specifications
Load Voltage	DC24V
Max. load current	50mA/point
Remaining voltage	2V or less
Isolation method	Photocoupler

NPN Specifications

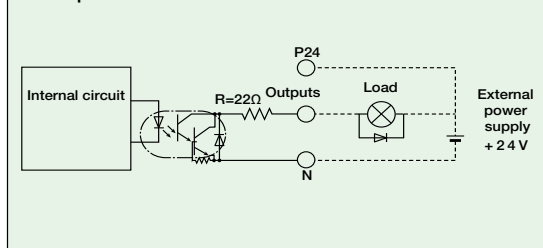

PNP Specifications

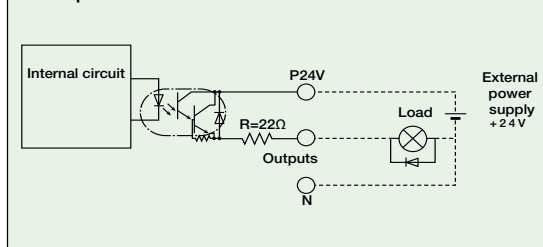

I/O Specifications

The 4 types of controllers (C/CG, CY, PL/PO, and SE) are classified by their respective I/O specifications. In addition, with the positioner type and solenoid valve type, the I/O signal details can be changed via the controller settings. As a result, a number of functions can be used.

Control Function by Type

Type	C/CG	CY	PL/PO	SE	Features
Name	Positioner type	Solenoid valve type	Pulse in-line control type	Serial communication type	
Positioner mode	○	×	×	○ (*1)	This is the basic operating mode, in which the user designates position numbers and inputs start signals.
Teaching mode	○	×	×	○ (*1)	In this mode, the slider (rod) moves based on an external signal, and the stopped positions can be registered as position data.
Solenoid valve mode	○	○	×	○ (*1)	The actuator can be moved simply by ON/OFF of position signals. This mode supports the same control signals you are already familiar with on solenoid valves of air cylinders.
Pulse train mode	×	×	○	×	In this mode, you can operate the actuator freely using pulse trains without inputting position data.
Network compatible	○ (*2)	×	×	○ (*3)	The controller can be connected to a DeviceNet or CC-Link network.

*1 Operates using network communications or serial communications.
 *2 Can make a direct connection to a field network with the network specifications.
 *3 Can be connected to a field network using a gateway unit.

527 PCON

- Slider Type
- Mini
- Standard
- Controllers Integrated
- Rod Type
- Mini
- Standard
- Controllers Integrated
- Table/Arm /FlatType
- Mini
- Standard
- Gripper/ Rotary Type
- Linear Servo Type
- Cleanroom Type
- Splash-Proof
- Controllers
- PMEC /AMEC
- PSEP /ASEP
- ROBO NET
- ERC2
- PCON
- ACON
- SCON
- PSEL
- ASEL
- SSEL
- XSEL
- Pulse Motor
- Servo Motor (24V)
- Servo Motor (200V)
- Linear Servo Motor

Explanation of I/O Signal Functions

The table below explains the functions allocated to the controller's I/O signal. Since the signals that can be used vary depending on the controller type and settings, check the signal table for each controller to confirm the available functions.

■ Signal Function Description

Classification	Signal abbreviations	Signal	Function description
Input	CSTR	PTP strobe signal (start signal)	Input this signal to cause the actuator to start moving to the position set by the command position number signal.
	PC1 to PC256	Command position number signal	This signal is used to input a target position number (binary input).
	BKRL	Brake forced release signal	This signal forcibly releases the brake.
	RMOD	Running mode switching signal	This signal can switch the running mode when the MODE switch on the controller is set to AUTO. (AUTO when this signal is OFF, or MANU when the signal is ON)
	*STP	Pause signal	Turning this signal OFF causes the moving actuator to decelerate to a stop. The actuator will resume the remaining movement if the signal is turned ON during the pause.
	RES	Reset signal	Turning this signal ON resets the alarms that are present. If this signal is turned ON while the actuator is paused (*STP is OFF), the remaining movement can be cancelled.
	SON	Servo ON signal	The servo remains on while this signal is ON, or off while the signal is OFF.
	HOME	Home return signal	Turning this signal ON performs home-return operation.
	MODE	Teaching mode signal	Turning this signal ON switches the controller to the teaching mode. (provided that CSTR, JOG+ and JOG- are all OFF and the actuator is not moving).
	JISL	JOG/INCHING switching signal	When the main signal is off, the JOG operation will be conducted for JOG+ and JOG-. When the signal is on, the unit will do the inching operation for JOG+ and JOG-.
	JOG+, JOG-	JOG signal	When the JISL signal is off and the JOG +/- signal turns on, the unit will jog in the + (positive) direction when the JOG + turns on and the - (negative) direction when the JOG - turns on. During the JOG operation, the unit slows to a stop when the JOG +/- signal turns off.
	PWRT	Teaching signal	In the teaching mode, specify a desired position number and then turn this signal ON for at least 20ms to write the current position to the specified position number.
	ST0 to ST6	Start position command	Turning this signal ON in the solenoid valve mode causes the actuator to move to the specified position. (Start signal is not required)
	TL	Torque limit selection signal	While this signal is ON, torque is limited by the value set by a parameter. The TLR signal turns on if torque has reached the specified value.
	Output	DCLR	Deviation counter clear signal
PEND/INP		In position signal	This signal turns ON when the actuator has entered the positioning band after movement. If the actuator has exceeded the positioning band, PEND does not turn OFF, but INP does. PEND and INP can be swapped within parameters.
PM1 to PM256		Positioning complete signal	This signal is used to output the position number achieved at the completion of positioning (binary output)
HEND		Home return completion signal	This signal turns ON upon completion of home return.
ZONE1		Zone signal	This signal turns ON when the current actuator position has entered the range specified by the parameters.
PZONE		Position zone signal	Turns ON when the actuator moves into a position within the range of the target position data that was set. PZONE can be used together with ZONE1, but PZONE is valid only during movement to a specified position.
RMDS		Running mode status signal	This outputs the operation mode status.
*ALM		Controller alarm status signal	This signal remains ON while the controller is not in the alarm condition, and turns OFF when an alarm has occurred.
MOVE		Moving signal	Turns ON while the actuator is moving (home return), including when there is push force.
SV		Servo ON status signal	This signal turns ON when servo is ON.
*EMGS		Emergency stop status signal	This signal remains ON while the controller is not in the emergency stop mode, and turns OFF once an emergency stop has been actuated.
MODES		Mode status signal	The mode signal input turns it ON when it goes into teaching mode. It turns OFF when it goes into normal mode.
WEND		Writing complete signal	This signal remains OFF after the controller has switched to the teaching mode. It turns ON upon completion of data write using the PWRT signal. If the PWRT signal is turned Off, this signal also turns OFF.
PE0 to PE6		Current position number signal	This signal turns ON after the controller has completed moving to the target position in the solenoid valve mode.
TLR		Torque limiting signal	This signal turns ON once the motor torque has reached the specified value in a condition where torque is being limited by the TL signal.
LSO to LS2		Limit switch output signal	Each signal turns ON when the current actuator position has entered the positioning band before or after the target position. If the actuator has already completed home return, these signals are output even before a movement command is issued or while the servo is OFF.
LOAD		Load output determination status signal	This signal turns ON once the motor torque has reached the specified value. (*PCON-CF dedicated signal)
TRQS	Torque level status signal	Turns ON when the motor current reaches the threshold. (*PCON-CF dedicated signal)	

(Note) Signals with asterisks (*) are normally ON and OFF during operation.

- Slider Type
- Mini
- Standard
- Controllers Integrated
- Pcd Type
- Mini
- Standard
- Controllers Integrated
- Table/Arm /FlatType
- Mini
- Standard
- Gripper/ Rotary Type
- Linear Servo Type
- Cleanroom Type
- Splash-Proof
- Controllers
- PMEC /AMEC
- PSEP /ASEP
- ROBO NET
- ERC2
- PCON
- ACON
- SCON
- PSEL
- ASEL
- SSEL
- XSEL
- Pulse Motor
- Servo Motor (24V)
- Servo Motor (200V)
- Linear Servo Motor

I/O Signal table

■ Positioner types (PCON-C / CG / CF)

Pin No.	Classification	Positioning Points	Parameters (select PIO pattern)					
			0	1	2	3	4	5
			Positioning mode	Teaching mode	256-point mode	512-point mode	Solenoid Valve Mode 1	Solenoid Valve Mode 2
		Zone signal	○	x	x	x	○	○
		P-zone signal	○	○	○	x	○	○
1A	24V		P24					
2A	24V		P24					
3A	-		NC					
4A	-		NC					
5A	Input	IN0	PC1	PC1	PC1	PC1	ST0	ST0
6A		IN1	PC2	PC2	PC2	PC2	ST1	ST1 (JOG+)
7A		IN2	PC4	PC4	PC4	PC4	ST2	ST2 (-)
8A		IN3	PC8	PC8	PC8	PC8	ST3	-
9A		IN4	PC16	PC16	PC16	PC16	ST4	-
10A		IN5	PC32	PC32	PC32	PC32	ST5	-
11A		IN6	-	MODE	PC64	PC64	ST6	-
12A		IN7	-	JISL	PC128	PC128	-	-
13A		IN8	-	JOG+	-	PC256	-	-
14A		IN9	BKRL	BKRL	BKRL	BKRL	BKRL	BKRL
15A		IN10	RMOD	RMOD	RMOD	RMOD	RMOD	RMOD
16A		IN11	HOME	HOME	HOME	HOME	HOME	-
17A		IN12	*STP	*STP	*STP	*STP	*STP	-
18A		IN13	CSTR	CSTR/PWRT	CSTR	CSTR	-	-
19A		IN14	RES	RES	RES	RES	RES	RES
20A	IN15	SON	SON	SON	SON	SON	SON	
1B	Output	OUT0	PM1	PM1	PM1	PM1	PE0	LSO
2B		OUT1	PM2	PM2	PM2	PM2	PE1	LS1 (TRQS)
3B		OUT2	PM4	PM4	PM4	PM4	PE2	LS2 (-)
4B		OUT3	PM8	PM8	PM8	PM8	PE3	-
5B		OUT4	PM16	PM16	PM16	PM16	PE4	-
6B		OUT5	PM32	PM32	PM32	PM32	PE5	-
7B		OUT6	MOVE	MOVE	PM64	PM64	PE6	-
8B		OUT7	ZONE1	MODES	PM128	PM128	ZONE1	ZONE1
9B		OUT8	PZONE	PZONE	PZONE	PM256	PZONE	PZONE
10B		OUT9	RMDS	RMDS	RMDS	RMDS	RMDS	RMDS
11B		OUT10	HEND	HEND	HEND	HEND	HEND	HEND
12B		OUT11	PEND	PEND/WEND	PEND	PEND	PEND	-
13B		OUT12	SV	SV	SV	SV	SV	SV
14B		OUT13	* EMGS	* EMGS	* EMGS	* EMGS	* EMGS	* EMGS
15B		OUT14	* ALM	* ALM	* ALM	* ALM	* ALM	* ALM
16B	OUT15	LOAD/TRQS	-	LOAD/TRQS	LOAD/TRQS	LOAD/TRQS	-	
17B	-		NC					
18B	-		NC					
19B	0V		N					
20B	0V		N					

(Note) The names of signals above inside () are functions before the unit returns home.
 (Note) Signals with asterisks (*) are normally ON, and OFF during operation.

■ Solenoid valve type (PCON-CY)

Pin No.	Classification	Positioning Points	Parameters (select PIO pattern)	
			0	1
			Solenoid valve mode 0	Solenoid valve mode 1
		Zone signal	x	x
		P-zone signal	x	○
1	24V			
2	0V			
3	Input	IN0	ST0	ST0
4		IN1	ST1 (JOG+)	ST1 (JOG+)
5		IN2	ST2 (RES)	ST2 (RES)
6	IN3	SON	SON	SON
7	Output	OUT0	LS0	PE0
8		OUT1	LS1 (TRQS)	PE1 (TRQS)
9		OUT2	LS2 (-)	PE2 (-)
10		OUT3	SV	PZONE
11		OUT4	HEND	HEND
12	OUT5	* ALM	* ALM	

(Note) The names of signals above inside () are functions before the unit returns home.
 (Note) Signals with asterisks (*) are normally ON, and OFF during operation.

■ Pulse Train Type (PCON-PL/PO)

Pin No.	Classification	Positioning Points	Parameters (select PIO pattern)	
			0	1
			Standard mode	Push mode
		Zone signal	x	x
		P-zone signal	x	x
1	24V			
2	0V			
3	Input	IN0	SON	SON
4		IN1	TL	TL
5		IN2	HOME	HOME
6	IN3	RES	RES / DCLR	
7	Output	OUT0	SV	SV
8		OUT1	INP	INP / TLR
9		OUT2	HEND	HEND
10	OUT3	* ALM	* ALM	
11	Input	* PP	* PP	
12		PP	PP	
13		* NP	* NP	
14		NP	NP	

(Note) Signals with asterisks (*) are normally ON, and OFF during operation.

529 PCON

Pulse train input type wiring diagram

■ Differential Receiver Method (PCON-PL)

Max. input pulse frequency : Max. 200 kpps
 Cable Length : Max. 10m

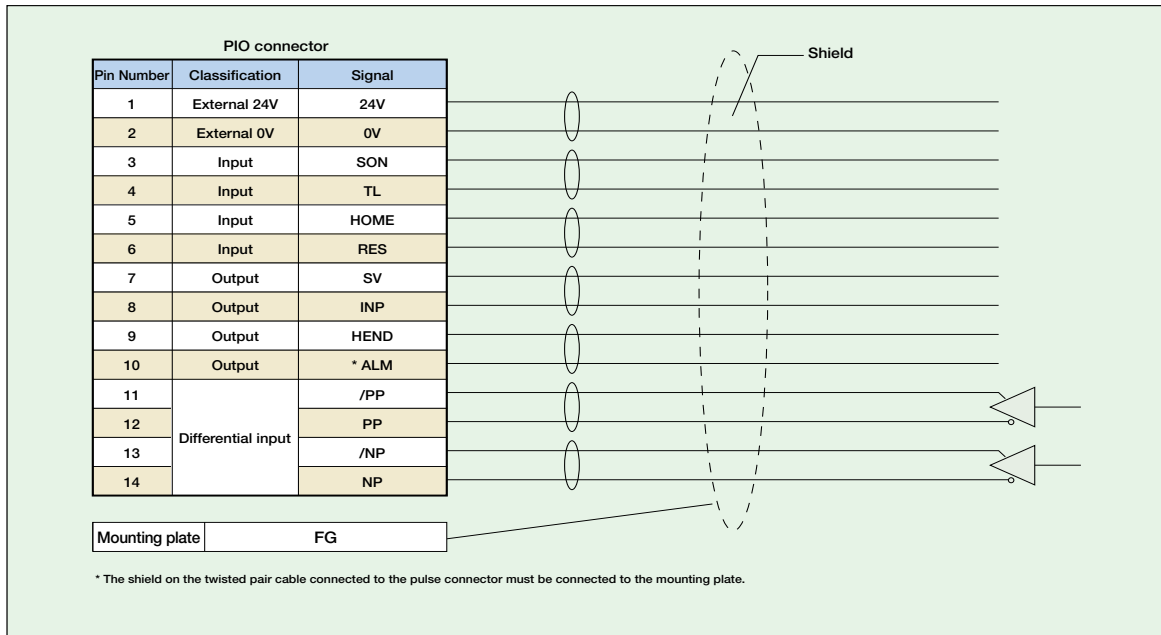

■ Open Collector Method (PCON-PO)

Max. input pulse frequency : Max. 60 kpps
 Cable Length : Max. 2m

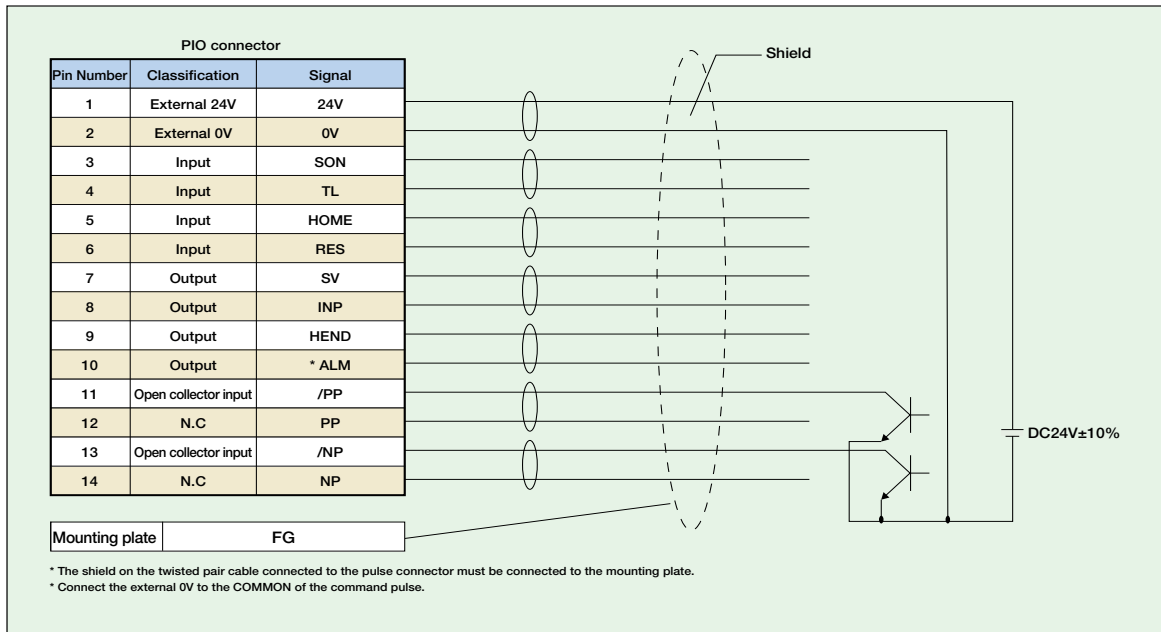

- Slider Type
- Mini
- Standard
- Controllers Integrated
- Pcd Type
- Mini
- Standard
- Controllers Integrated
- Table/Arm /FlatType
- Mini
- Standard
- Gripper/ Rotary Type
- Linear Servo Type
- Cleanroom Type
- Splash-Proo
- Controllers
- PMEC /AMEC
- PSEP /ASEP
- ROBO NET
- ERC2
- PCON
- ACON
- SCON
- PSEL
- ASEL
- SSEL
- XSEL
- Pulse Motor
- Servo Motor (24V)
- Servo Motor (200V)
- Linear Servo Motor

Command Pulse Input State

Command pulse train state		Input terminal	During forward operation	During reversed operation		
Negative logic	Forward pulse train	PP·/PP				
	Reversed pulse train	NP·/NP				
	The forward pulse train causes the motor to rotate forward, and the reverse pulse train causes the motor to rotate in reverse.					
	Pulse train	PP·/PP				
	Symbols	NP·/NP	Low	High		
	The command pulse is used for the amount of motor rotation, and the command symbol is used for rotational direction.					
	A/B phase pulse train	A/B phase pulse train	PP·/PP			
			NP·/NP			
		An A/B phase pulse with a 90° phase difference (multiplier is 4) is used to generate commands for the amount of rotation and rotational direction.				
		Positive logic	Forward pulse train	PP·/PP		
Reversed pulse train			NP·/NP			
Pulse train	PP·/PP					
Symbols	NP·/NP		High	Low		
A/B phase pulse train	PP·/PP					
	NP·/NP					

Table of specifications

Item	Specifications							
	CF	C	CG	CY	PL	PO	SE	
Controller type	CF	C	CG	CY	PL	PO	SE	
Connected actuator (*1)	RCP2-RA10C RCP2-HS8C (R) RCP2W-SA16C	RCP3 / RCP2 series actuator (Note 1)						
Number of control axes	1-axis							
Operating method	Positioner type		Solenoid valve type		Pulse train input type		Serial communication type	
Positioning Points	512 points		3 points		-		64 points	
Backup memory	EEPROM							
I/O connector	40-pin connector			12-pin connector		14-pin connector		None
Number of I/O	16 input points/16 output points			4 input points/6 output points		4 input points/4 output points		None
I/O power	External supply DC24V±10%							
Serial Communication	RS485 1ch							
Peripheral device communication cable	CB-PAC-PIO □□□			CB-PACY-PIO □□□		CB-PACPU-PIO □□□		CB-RCB-CTL002
Command pulse train input method	-			-		Differential line driver	Open collector	-
Max. input pulse frequency (Note 2)	-			-		Max. 200 kpps	Max. 60 kpps	-
Position detection method	Incremental encoder							
Drive-source cutoff relay at emergency stop	Integrated			External				
Forced release of electromagnetic brake	Brake release switch ON/OFF			ON/OFF terminal signal inside the power terminal for brake release				
Input Supply Voltage	DC 24 V ± 10%							
Power Supply Capacity	Max. 6A (*2)	2A max.						
Dielectric strength voltage	DC500V 1MΩ							
Vibration resistance	XYZ directions		10 to 57Hz, One side amplitude: 0.035mm (continuous), 0.075mm (intermittent) 58 to 150Hz, 4.9m/s ² (continuous), 9.8m/s ² (intermittent)					
Ambient operating temperature	0 ~ 40°C							
Ambient operating humidity	10 - 95% (non-condensing)							
Ambient operating atmosphere	Without corrosion gases							
Protection class	IP20							
Weight	Approx. 320g	Approx. 300g			Approx. 130g			

(Note 1) The high-thrust type (RA10C), high-speed type (HS8C/HS8R) and waterproof type (RCP2W-SA16) cannot be operated.
 (Note 2) With the open collector specification, keep the maximum input frequency to 60 kpps or below to prevent malfunction. For applications exceeding 60kpps, use the differential line driver.
 (*1) RCP2-RA10C/HS8C/HS8R and RCP2W-SA16C can only operate with PCON-CF.
 Other RCP2 / RCP3 Series actuators can be operated with C / CG / CY / PL / PO / SE.
 (*2) Inrush current peak: 10A

531 PCON

External Dimensions

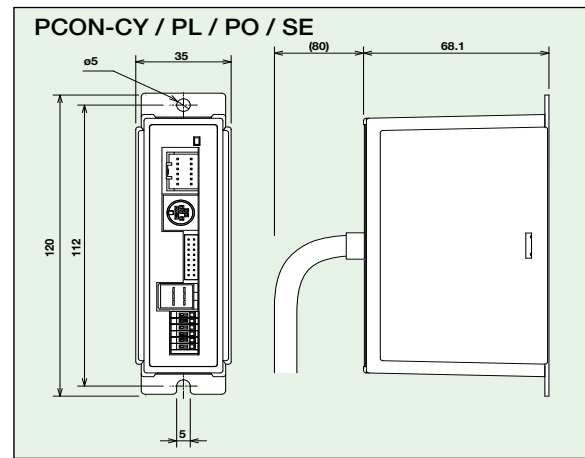
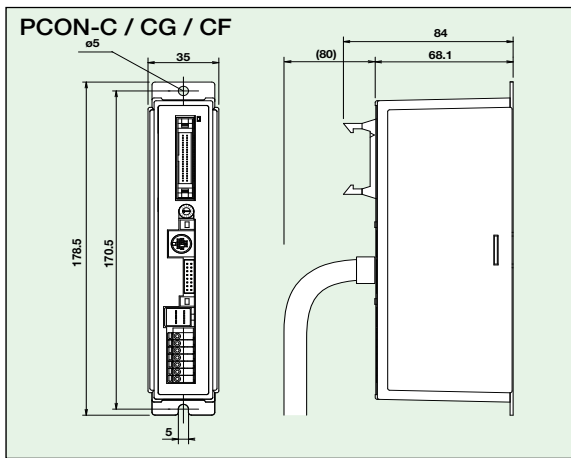

Name of Each Part

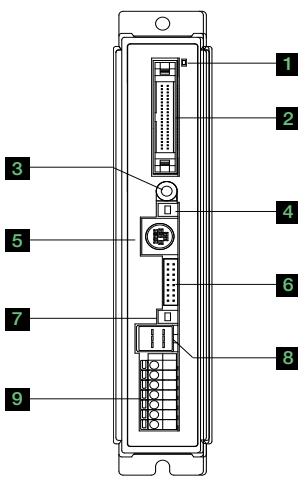

C / CG / CF type

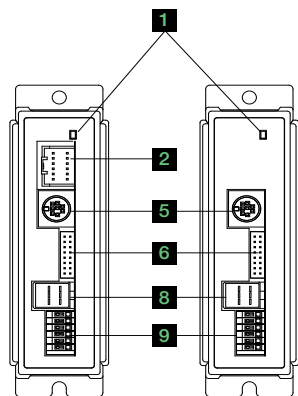

CY / PL / PO Type

SE Type

* PIO connectors are:
CY: 12 pin
PL/PO: 14 pin

1 LED display

These LED colors indicate the condition of the controller.

Lit (green) Servo ON Lit (red) Alarm activated Unlit Servo OFF Blinking (green) Automatic servo-off
Emergency stop

2 PIO connector

Connects a cable for communicating with a PLC or other external equipment.

3 Address-setting rotary switch

This switch sets the addresses for controllers used when the unit is linked with other controllers.

4 Mode switch

Switches between manual teaching operations (MANU) and automatic operations (AUTO).

Operation details

MANU	I/O commands are not accepted. Data can be written from a teaching pendant or PC.
AUTO	I/O commands are valid, while operations from a teaching pendant or PC are not accepted. However, monitoring is possible.

5 SIO connector

Connects a teaching pendant, PC cable, controller, or gateway unit to a controller.

Operation details

Pin No.	Signal	Name	Remarks
1	SGA	Positive side, RS485 differential signal	
2	SGB	Negative side, RS485 differential signal	
3	5V	+5V output	For RS232/485 conversion
4	ENBL	Enable signal	
5	EMGA	EMG line connection to external equipment	
6	24V	24-V power for T/P	For T/P
7	0V	GND	
8	EMGB	EMG line connection to external equipment	
9	0V	EMG line connection to external equipment ground	

6 Encoder brake connector

Connects the encoder/brake cable for the actuator.

7 Brake release switch

This switch forces the brake to release.

8 Motor connector

Connects the motor cable for the actuator.

9 Power terminal block

Main power for controller(s), emergency stop

C / CG type

Terminal number	Signal	Name
7	S1	External drive-source cutoff for TP_
6	S2	EMG terminal
5	MPI	Motor drive-source cutoff terminal
4	MPO	Motor drive-source cutoff terminal
3	24V	Positive side of the 24-V power supply
2	0V	Negative side of the 24-V power supply
1	EMG	EMG signal (application of 24 V)

CY / PL / PO / SE type

Terminal number	Signal	Name
6	BK	BK release
5	MPI	Motor drive-source cutoff terminal
4	MPO	Motor drive-source cutoff terminal
3	24V	Positive side of the 24-V power supply
2	0V	Negative side of the 24-V power supply
1	EMG	EMG signal (application of 24 V)

- Slider Type
- Mini
- Standard
- Controllers Integrated
- Pcd Type
- Mini
- Standard
- Controllers Integrated
- Table/Arm /FlatType
- Mini
- Standard
- Gripper/ Rotary Type
- Linear Servo Type
- Cleanroom Type
- Splash-Proof
- Controllers
- PMEC /AMEC
- PSEP /ASEP
- ROBO NET
- ERC2
- PCON
- ACON
- SCON
- PSEL
- ASEL
- SSEL
- XSEL
- Pulse Motor
- Servo Motor (24V)
- Servo Motor (200V)
- Linear Servo Motor

Option

Teaching Pendant

- Features** This is a teaching device that provides information on functions such as the position input, test runs, and monitoring.
- Model** **CON-PT-M-ENG** (Touch panel teaching pendant)
CON-T-ENG (Standard type)
RCM-E-ENG (Simple teaching pendant)

- Configuration**

Note: The version of RCM-E-ENG that can be used with ROBOTNET is 2.08 or later.

- CON-T-ENG Options**
 - Wall-mounting hook Model HK-1
 - Strap Model STR-1

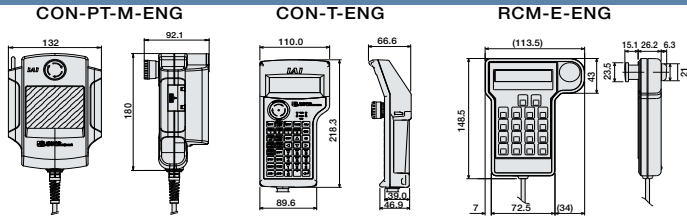

Specifications

Item	CON-PT-M-ENG	CON-T-ENG	RCM-E-ENG
Data input	○	○	○
Actuator motion	○	○	○
Ambient Operating temp/humidity	Temp: 0~40°C; Humidity: 85% RH or below		
Ambient Operating atmosphere	No corrosive gases. Especially no dust.		
Protection class	IP40	IP54	—
Weight	Approx. 750g	Approx. 400g	Approx. 400g
Cable length	5m		
Display	3-color LED touch panel with backlight	20 char. x 4 lines LCD display	16 char. x 2 lines LCD display

PC Software (Windows Only)

- Features** A startup support software for inputting positions, performing test runs, and monitoring. With enhancements for adjustment functions, the startup time is shortened.

- Model** **RCM-101-MW** (External device communications cable + RS232 conversion unit)

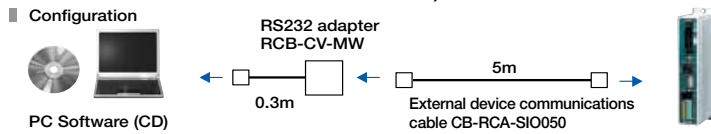

- Model** **RCM-101-USB** (External device communications cable + USB adapter + USB cable)

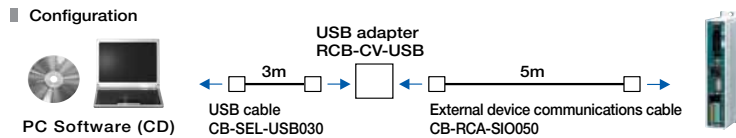

Spare Parts

When you need spare parts after purchasing the product, such as when replacing a cable, refer to the list of models below.

Motor Cable for RCP2

Model **CB-RCP2-MA** * The standard cable for the motor cable is the robot cable. * Enter the cable length (L) into . Compatible to a maximum of 20 meters. Ex.: 080 = 8 m

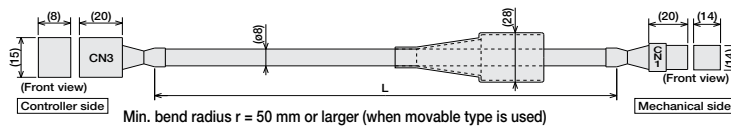

	CN3	M cable	CN1	
-1318119-3 (AMP)	Orange	A	A1	1 A Yellow
	Gray	VMM	A2	2 VMM Gray
	White	B	A3	3 A Orange
	Yellow	A	B1	4 B Yellow (Green)
	Pink	VMM	B2	5 VMM Pink
	Yellow (Green)	B	B3	6 B White

Encoder Cable/Encoder Robot Cable for RCP2

Model **CB-RCP2-PB** / **CB-RCP2-PB** - **RB** * The standard cable for the encoder cable is the normal cable. * Enter the cable length (L) into . Compatible to a maximum of 20 meters. A robot cable can be specified as an option. Ex.: 080 = 8 m

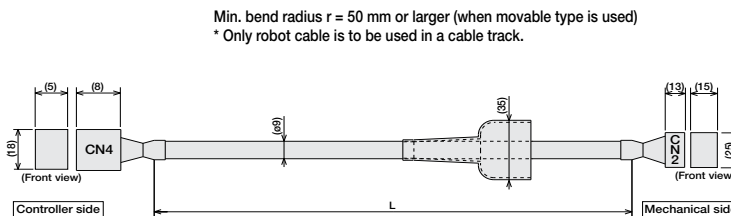

C N 4	Cable color	Robot Cable	Signal	Pin No.	Cable color	Robot Cable	C N 2
PHR-101S (JST)	Blue (Red 1)	Orange (Black 2)	S +	16	—	—	—
	White	Orange (Red 2)	S -	15	—	—	—
	Red	Orange (Red 1)	K +	14	1 E N A	Brown	Light Gray (Red 1)
	Gray	Orange (Red 1)	K -	13	2 E N A	Green	Light Gray (Red 1)
	Brown	Light Gray (Black 1)	E N A	12	3 S N B	Purple	White (Red 1)
	Green	Light Gray (Red 1)	E N A	11	4 B	Yellow (Green)	White (Red 1)
	Purple	White (Red 1)	E N B	10	5	—	—
	Pink	White (Red 1)	E N B	9	6	—	—
	—	—	—	8	7	—	—
	Yellow	Yellow (Black 1)	V P S	7	8	—	—
	Orange	Pink (Red 1)	V B B	6	9 GND	Blue	Pink (Black 1)
	Blue	Pink (Black 1)	GND	5	10 V B S	Orange	Pink (Red 1)
	—	—	GND	4	11 V P S	Yellow	Yellow (Red 1)
	—	—	NO	3	12	—	—
	—	—	NO	2	13 L S +	Blue (Red 1)	Orange (Black 2)
	—	—	FG	1	14 L S -	White	Orange (Red 2)
	Ground	Ground	FG	1	15	—	—
				16 B K +	Red	Orange (Black 1)	
				17 B K -	Gray	Orange (Red 1)	
				18 F G	Ground	Ground	

533 PCON

Encoder Cable / Encoder Robot Cable for the RCP2 High-speed Type / High-thrust Type / Waterproof Type

Model **CB-RFA-PA** / **CB-RFA-PA** - **RB** * The standard cable for the encoder cable is the normal cable. * Enter the cable length (L) into . Compatible to a maximum of 20 meters. Ex.: 080 = 8 m

Min. bend radius r = 50 mm or larger (when movable type is used)
* Only robot cable is to be used in a cable track.

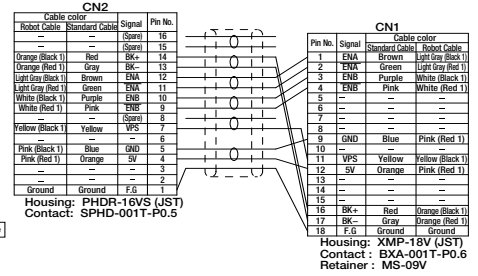
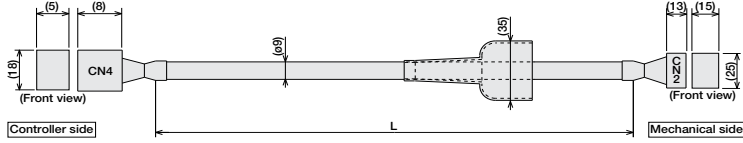

Motor-Encoder Integrated Type Cable for RCP3/RCP2 (Limited to RCP2-GRSS/GRLS/GRST/SRA4R/SRGS4R/SRGD4R)

Model **CB-PCS-MPA** * The standard cable is robot cable. * Enter the cable length (L) into . Compatible to a maximum of 20 meters. Ex.: 080 = 8 m

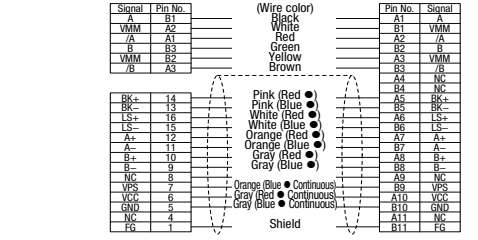
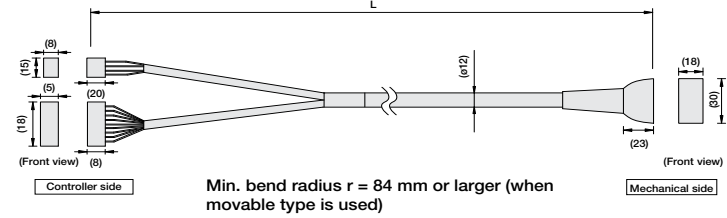

Positioner I/O Cable (for PCON-C/CG)

Model **CB-PAC-PIO** * Enter the cable length (L) into . Compatible to a maximum of 10 meters. Ex.: 080 = 8 m

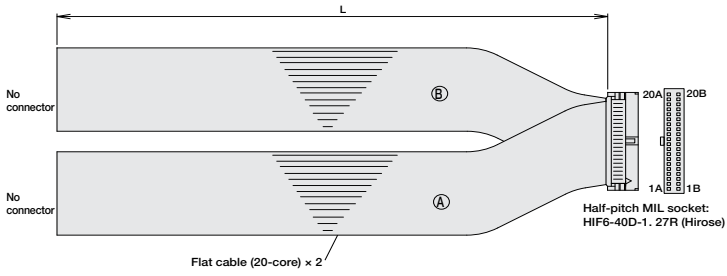

No.	Signal	Cable Color	Wire
1A	24V	Brown-1	
2A	24V	Red-1	
3A	-	Orange-1	
4A	-	Yellow-1	
5A	INO	Green-1	
6A	IN1	Blue-1	
7A	IN2	Purple-1	
8A	IN3	Gray-1	
9A	IN4	White-1	
10A	IN5	Black-1	
11A	IN6	Brown-2	
12A	IN7	Red-2	
13A	IN8	Orange-2	
14A	IN9	Yellow-2	
15A	IN10	Green-2	
16A	IN11	Blue-2	
17A	IN12	Purple-2	
18A	IN13	Gray-2	
19A	IN14	White-2	
20A	IN15	Black-2	

Solenoid Valve Type I/O Cable (for PCON-CY)

Model **CB-PACY-PIO** * Enter the cable length (L) into . Compatible to a maximum of 10 meters. Ex.: 080 = 8 m

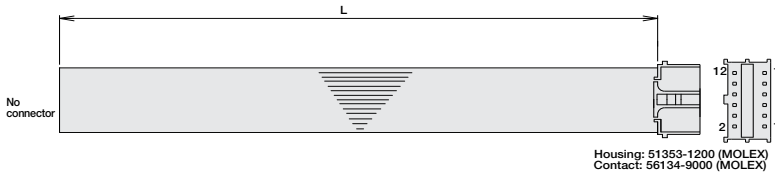

No.	Signal	Cable Color	Wire
1	24V	Brown-1	
2	0V	Red-1	
3	INO	Orange-1	
4	IN1	Yellow-1	
5	IN2	Green-1	
6	IN3	Blue-1	
7	OUT0	Purple-1	
8	OUT1	Gray-1	
9	OUT2	White-1	
10	OUT3	Black-1	
11	OUT4	Brown-2	
12	OUT5	Red-2	

Pulse Train Control I/O Cable (for PCON-PL/PO)

Model **CB-PACPU-PIO** * Enter the cable length (L) into . Compatible to a maximum of 10 meters. Ex.: 080 = 8 m

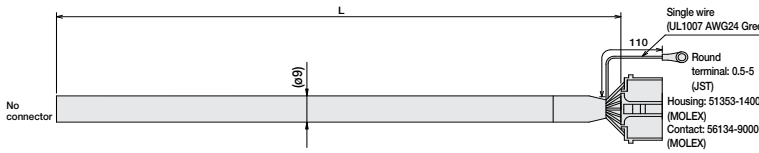

No.	Signal	Cable Color	Wire
1	IO 24V	White/Black	
2	IO 24V	White/Black	
3	INO	Red	
4	IN1	White/Red	
5	IN2	Green	
6	IN3	White/Green	
7	OUT0	Yellow	
8	OUT1	White/Yellow	
9	OUT2	Brown	
10	OUT3	White/Brown	
11	FP	Blue	
12	PG	White/Blue	
13	NP	Gray	
14	NS	White/Gray	

- Slider Type
- Mini
- Standard
- Controllers Integrated
- PCD Type
- Mini
- Standard
- Controllers Integrated
- Table/Arm /FlatType
- Mini
- Standard
- Controllers Integrated
- Table/Arm /FlatType
- Mini
- Standard
- Gripper/ Rotary Type
- Linear Servo Type
- Cleanroom Type
- Splash-Proof
- Controllers
- PMEC /AMEC
- PSEP /ASEP
- ROBO NET
- ERC2
- PCON
- ACON
- SCON
- PSEL
- ASEL
- SSEL
- XSEL
- Pulse Motor
- Servo Motor (24V)
- Servo Motor (200V)
- Linear Servo Motor



■ Models C / CG / CY / PL / PO / SE

Position Controllers
For RCA2/RCA

C/CG CY PL/PO SE

List of models

This position controller enables movement of the RCA2/RCA series actuators. A line-up of 5 types to support various controlling methods.

Type	C	CG	CY	PL/PO	SE
Name	Positioner type	Safety category compatible type	Solenoid valve type	Pulse train control type	Serial Communication Type
External view					
Description	Positioner capable of a maximum of 512 points of Positioning	Conforming to type C safety category specifications	Can be operated using the same control as the air cylinder type	For pulse train control	For serial communication
Position points	512 points	512 points	3 points	(-)	64 points

Model

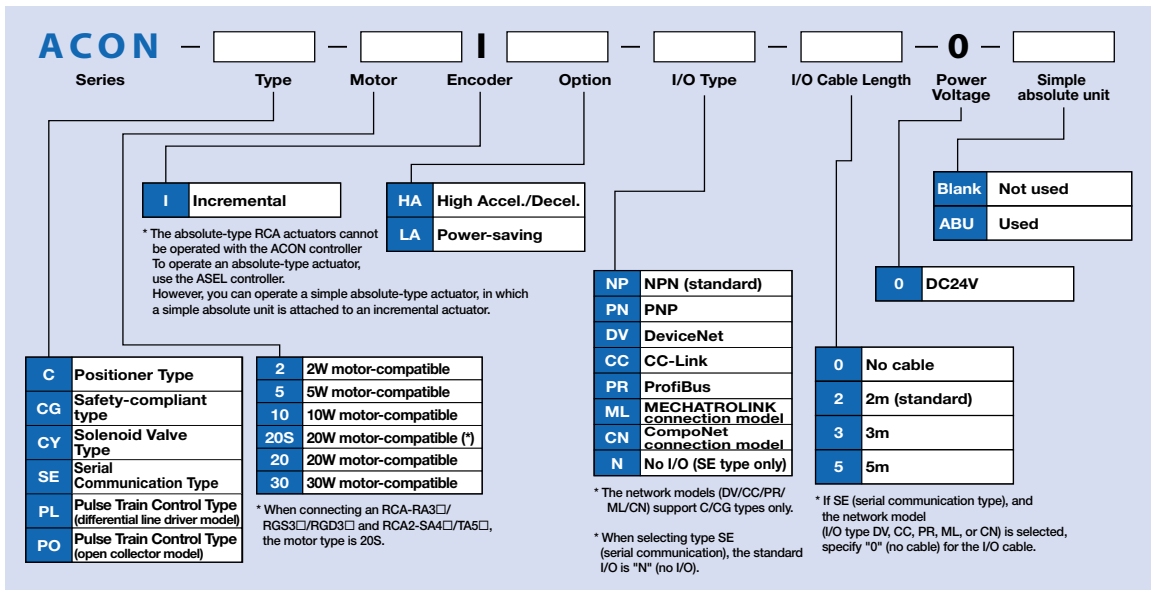

535 ACON

System configuration

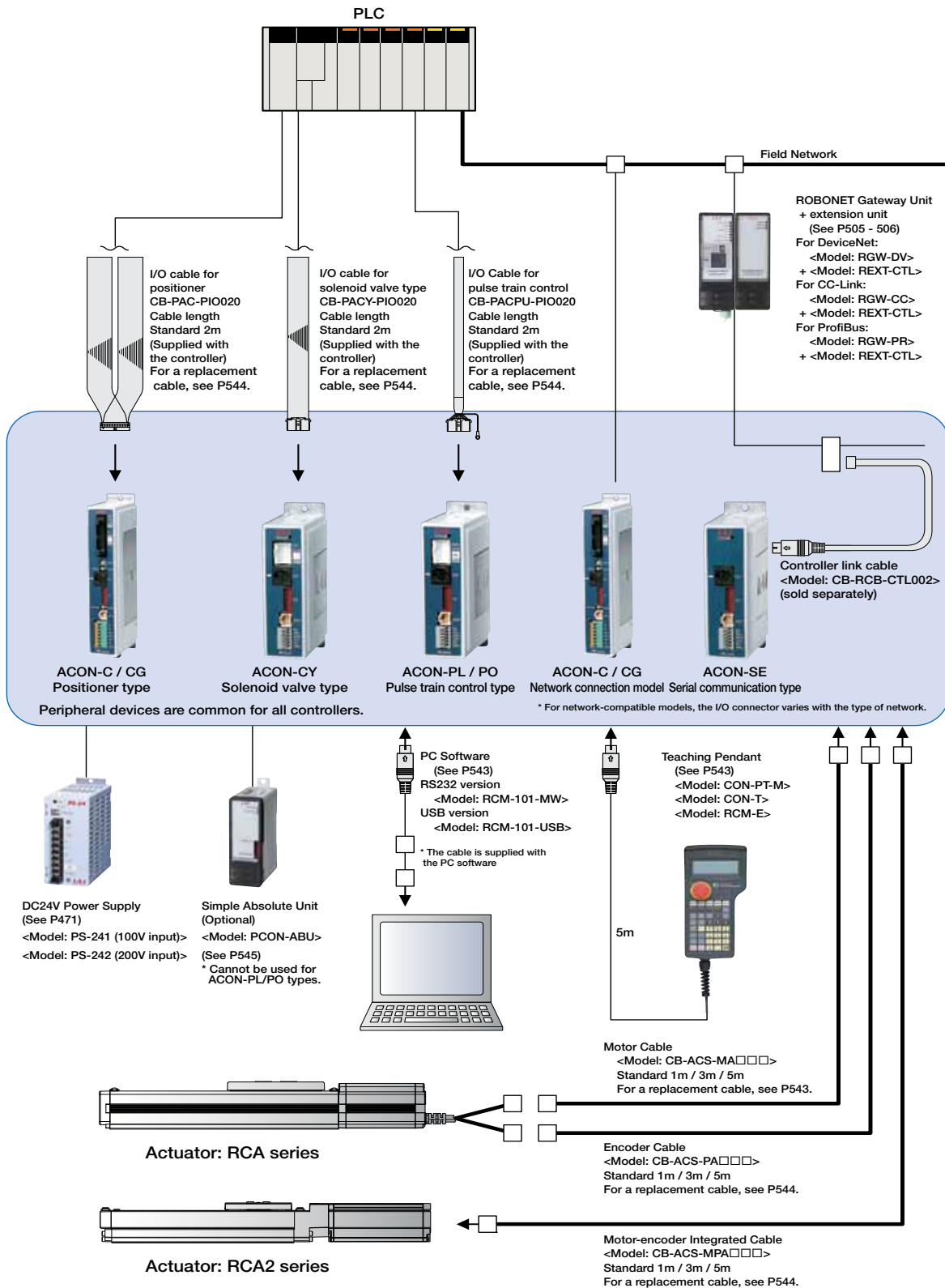

- Slider Type
- Mini
- Standard
- Controllers Integrated
- Pcd Type
- Mini
- Standard
- Controllers Integrated
- Table/Arm /FlatType
- Mini
- Standard
- Gripper/ Rotary Type
- Linear Servo Type
- Cleanroom Type
- Splash-Prod
- Controllers
- PMEC /AMEC
- PSEP /ASEP
- ROBO NET
- ERC2
- PCON
- ACON
- SCON
- PSEL
- ASEL
- SSEL
- XSEL
- Pulse Motor
- Servo Motor (24V)
- Servo Motor (200V)
- Linear Servo Motor

I/O Specifications

Input section External input specifications

Item	Specifications
Input voltage	DC24V ±10%
Input current	4mA/circuit
Leak current	1mA max./point
Isolation method	Photocoupler

NPN Specifications

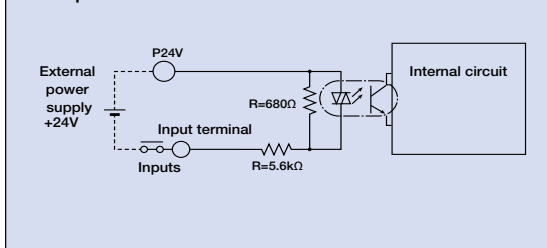

PNP Specifications

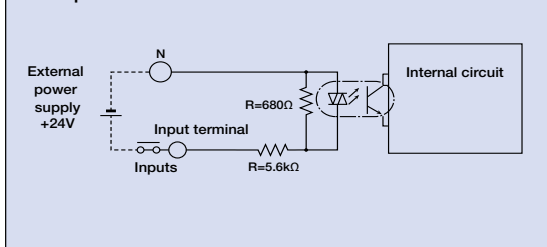

Output section External output specifications

Item	Specifications
Load Voltage	DC24V
Max. load current	50mA/point
Remaining voltage	2V or less
Isolation method	Photocoupler

NPN Specifications

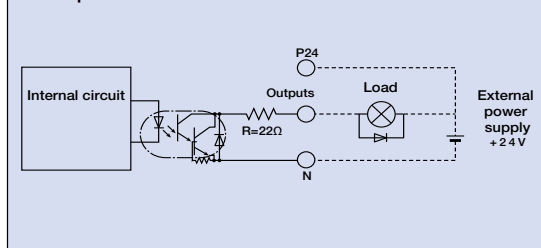

PNP Specifications

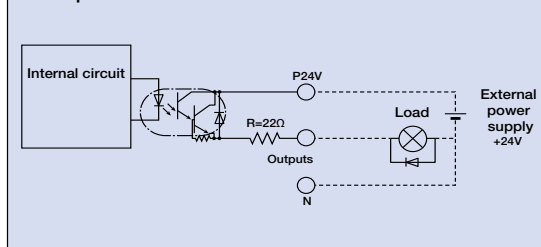

I/O Specifications

The 4 types of controllers (C/CG, CY, PL/PO, and SE) are classified by their respective I/O specifications. Also, for the positioner type and solenoid valve type, the I/O signal information can be changed in the controller settings, so multiple functions can be effectively used.

Control Function by Type

Type	C/CG	CY	PL/PO	SE	Features
Name	Positioner type	Solenoid valve type	Pulse train control type	Serial communication type	
Positioner mode	○	✕	✕	○ (*1)	This is the basic operating mode, in which the user designates position numbers and inputs start signals.
Teaching mode	○	✕	✕	○ (*1)	In this mode, the slider (rod) moves based on an external signal, and the stopped positions can be registered as position data.
Solenoid valve mode	○	○	✕	○ (*1)	The actuator can be moved simply by ON/OFF position signals. This mode supports the same control signals you are already familiar with on solenoid valves of air cylinders.
Pulse train mode	✕	✕	○	✕	In this mode, you can operate the actuator freely without inputting position data.
Network compatible	○ (*2)	✕	✕	○ (*3)	The controller can be connected to a DeviceNet or CC-Link network.

*1 Operates using network communications or serial communications.

*2 Can make a direct connection to a field network with the network specifications.

*3 Can be connected to a field network using a gateway unit.

537

ACON

Sold & Serviced By:

ELECTROMATE

Toll Free Phone (877) SERV098

Toll Free Fax (877) SERV099

www.electromate.com

sales@electromate.com

- Slider Type
- Mini
- Standard
- Controllers Integrated
- Rod Type
- Mini
- Standard
- Controllers Integrated
- Table/Arm /FlatType
- Mini
- Standard
- Gripper/ Rotary Type
- Linear Servo Type
- Cleanroom Type
- Splash-Proof
- Controllers
- PMEC /AMEC
- PSEP /ASEP
- ROBO NET
- ERC2
- PCON
- ACON
- SCON
- PSEL
- ASEL
- SSEL
- XSEL
- Pulse Motor
- Servo Motor (24V)
- Servo Motor (200V)
- Linear Servo Motor

Explanation of I/O Signal Functions

The table below explains the functions allocated to the controller's I/O signal. Since the signals that can be used vary depending on the controller type and settings, check the signal table for each controller to confirm the available functions.

■ Signal Function Description

Classification	Signal abbreviations	Signal	Function description
Input	CSTR	Start signal	Input this signal to cause the actuator to start moving to the position set by the command position number signal.
	PC1 to PC256	Command position number signal	This signal is used to input a target position number (binary input).
	BKRL	Brake forced release signal	This signal forcibly releases the brake.
	RMOD	Running mode switching signal	This signal can switch the running mode when the MODE switch on the controller is set to AUTO. (AUTO when this signal is OFF, or MANU when the signal is ON).
	* STP	Pause signal	Turning this signal OFF causes the moving actuator to decelerate to a stop. The actuator will resume the remaining movement if the signal is turned ON during the pause.
	RES	Reset signal	Turning this signal ON resets the alarms that are present. If this signal is turned ON while the actuator is paused (*STP is OFF), the remaining movement can be cancelled.
	SON	Servo ON signal	The servo remains on while this signal is ON, or off while the signal is OFF.
	HOME	Home return signal	Turning this signal ON performs home-return operation.
	MODE	Teaching mode signal	Turning this signal ON switches the controller to teaching mode (provided that CSTR, JOG+ and JOG- are all OFF and the actuator is not moving).
	JISL	JOG/INJOG switching signal	When the main signal is off, the JOG operation will be conducted for JOG+ and JOG-. When the signal is on, the unit will do the inching operation for JOG+ and JOG-.
	JOG+, JOG-	JOG signal	When the JISL signal is off and the JOG +/- signal turns on, the unit will jog in the + (positive) direction when the JOG + turns on and the - (negative) direction when the JOG - turns on. During the JOG operation, the unit slows to a stop when the JOG +/- signal turns off.
	PWRT	Teaching signal	In the teaching mode, specify a desired position number and then turn this signal ON for at least 20ms to write the current position to the specified position number.
	ST0 to ST6	Start position command	Turning this signal ON in the solenoid valve mode causes the actuator to move to the specified position. (Start signal is not required)
	TL	Torque limit selection signal	While this signal is ON, torque is limited by the value set by a parameter. The TLR signal turns on if torque has reached the specified value. (Dedicated pulse train type)
	Output	DCLR	Deviation counter clear signal
PEND/INP		In position signal	This signal turns ON when the actuator has entered the positioning band after movement. If the actuator has exceeded the positioning band, PEND does not turn OFF, but INP does. PEND and INP can be swapped within parameters.
PM1 to PM256		Position complete signal	This signal is used to output the position number achieved at the completion of positioning (binary output)
HEND		Home return completion signal	This signal turns ON upon completion of home return.
ZONE1		Zone signal	This signal turns ON when the current actuator position has entered the range specified by the parameters.
PZONE		Positioning zone signal	Turns ON when actuator moves into a position within the range of the target position data that was set. PZONE can be used together with ZONE1, but PZONE is valid only during movement to a specified position.
RMDS		Running mode status signal	This outputs the operation mode status.
* ALM		Controller alarm status signal	This signal remains ON while the controller is not in the alarm condition, and turns OFF when an alarm has occurred.
MOVE		Moving signal	Turns ON while the actuator is moving (home return), including when there is push force.
SV		Servo ON status signal	This signal turns ON when servo is ON.
* EMGS		Emergency stop status signal	This signal remains ON while the controller is not in the emergency stop mode, and turns OFF once an emergency stop has been actuated.
MODES		Mode status signal	The mode signal input turns it ON when it goes into teaching mode. It turns OFF when it goes into normal mode.
WEND		Writing complete signal	This signal remains OFF after the controller has switched to the teaching mode. It turns ON upon completion of data write using the PWRT signal. If the PWRT signal is turned Off, this signal also turns OFF.
PE0 to PE6		Current position number signal	This signal turns ON after the controller has completed moving to the target position in the solenoid valve mode.
TLR		Torque limiting signal	This signal turns ON once the motor torque has reached the specified value in a condition where torque is being limited by the TL signal. (Dedicated pulse train type)
LSO to LS2	Limit switch output signal	Each signal turns ON when the current actuator position has entered the positioning band before or after the target position. If the actuator has already completed home return, these signals are output even before a movement command is issued or while the servo is OFF. (Dedicated Solenoid Valve Mode)	

(Note) Signals with asterisks (*) are normally ON and OFF during operation.

- Slider Type
- Mini
- Standard
- Controllers Integrated
- Pcd Type
- Mini
- Standard
- Controllers Integrated
- Table/Arm /FlatType
- Mini
- Standard
- Gripper/ Rotary Type
- Linear Servo Type
- Cleanroom Type
- Splash-Proof
- Controllers
- PMEC /AMEC
- PSEP /ASEP
- ROBO NET
- ERC2
- PCON
- ACON
- SCON
- PSEL
- ASEL
- SSEL
- XSEL
- Pulse Motor
- Servo Motor (24V)
- Servo Motor (200V)
- Linear Servo Motor

I/O Signal table

■ Positioner type (ACON-C / CG)

Pin No.	Classification	Positioning Points	Parameters (select PIO pattern)					
			0	1	2	3	4	5
			Positioning mode	Teaching mode	256-point mode	512-point mode	Solenoid Valve Mode 1	Solenoid Valve Mode 2
		Zone signal	○	x	x	x	○	○
		P-zone signal	○	○	○	x	○	○
1A	24V		P24					
2A	24V		P24					
3A	-		NC					
4A	-		NC					
5A	Input	IN0	PC1	PC1	PC1	PC1	ST0	ST0
6A		IN1	PC2	PC2	PC2	PC2	ST1	ST1 (JOG+)
7A		IN2	PC4	PC4	PC4	PC4	ST2	ST2 (-)
8A		IN3	PC8	PC8	PC8	PC8	ST3	-
9A		IN4	PC16	PC16	PC16	PC16	ST4	-
10A		IN5	PC32	PC32	PC32	PC32	ST5	-
11A		IN6	-	MODE	PC64	PC64	ST6	-
12A		IN7	-	JISL	PC128	PC128	-	-
13A		IN8	-	JOG+	-	PC256	-	-
14A		IN9	BKRL	BKRL	BKRL	BKRL	BKRL	BKRL
15A		IN10	RMOD	RMOD	RMOD	RMOD	RMOD	RMOD
16A		IN11	HOME	HOME	HOME	HOME	HOME	-
17A		IN12	* STP	* STP	* STP	* STP	* STP	-
18A		IN13	CSTR	CSTR/PWRT	CSTR	CSTR	-	-
19A		IN14	RES	RES	RES	RES	RES	RES
20A	IN15	SON	SON	SON	SON	SON	SON	
1B	Output	OUT0	PM1	PM1	PM1	PM1	PE0	LS0
2B		OUT1	PM2	PM2	PM2	PM2	PE1	LS1
3B		OUT2	PM4	PM4	PM4	PM4	PE2	LS2 (-)
4B		OUT3	PM8	PM8	PM8	PM8	PE3	-
5B		OUT4	PM16	PM16	PM16	PM16	PE4	-
6B		OUT5	PM32	PM32	PM32	PM32	PE5	-
7B		OUT6	MOVE	MOVE	PM64	PM64	PE6	-
8B		OUT7	ZONE1	MODES	PM128	PM128	ZONE1	ZONE1
9B		OUT8	PZONE	PZONE	PZONE	PM256	PZONE	PZONE
10B		OUT9	RMDS	RMDS	RMDS	RMDS	RMDS	RMDS
11B		OUT10	HEND	HEND	HEND	HEND	HEND	HEND
12B		OUT11	PEND	PEND/WEND	PEND	PEND	PEND	-
13B		OUT12	SV	SV	SV	SV	SV	SV
14B		OUT13	* EMGS	* EMGS	* EMGS	* EMGS	* EMGS	* EMGS
15B		OUT14	* ALM	* ALM	* ALM	* ALM	* ALM	* ALM
16B	OUT15	-	-	-	-	-	-	
17B	-		NC					
18B	-		NC					
19B	0V		N					
20B	0V		N					

(Note) The names of signals above inside () are functions before the unit returns home.
 (Note) Signals with asterisks (*) are normally ON, and OFF during operation.

■ Solenoid valve type (ACON-CY)

Pin No.	Classification	Positioning Points	Parameters (select PIO pattern)	
			0	1
			Solenoid valve mode 0	Solenoid valve mode 1
		Zone signal	x	x
		P-zone signal	x	○
1	24V			
2	0V			
3	Input	IN0	ST0	ST0
4		IN1	ST1 (JOG+)	ST1 (JOG+)
5		IN2	ST2 (RES)	ST2 (RES)
6	IN3	SON	SON	
7	Output	OUT0	LS0	PE0
8		OUT1	LS1	PE1
9		OUT2	LS2 (-)	PE2 (-)
10		OUT3	SV	PZONE
11		OUT4	HEND	HEND
12	OUT5	* ALM	* ALM	

(Note) The names of signals above inside () are functions before the unit returns home.
 (Note) Signals with asterisks (*) are normally ON, and OFF during operation.

■ Pulse Train Type (ACON-PL/PO)

Pin No.	Classification	Positioning Points	Parameters (select PIO pattern)	
			0	1
			Standard mode	Push mode
		Zone signal	x	x
		P-zone signal	x	x
1	24V			
2	0V			
3	Input	IN0	SON	SON
4		IN1	TL	TL
5		IN2	HOME	HOME
6	IN3	RES	RES / DCLR	
7	Output	OUT0	SV	SV
8		OUT1	INP	INP / TLR
9		OUT2	HEND	HEND
10		OUT3	* ALM	* ALM
11	Input		* PP	* PP
12			PP	PP
13			* NP	* NP
14			NP	NP

(Note) Signals with asterisks (*) are normally ON, and OFF during operation.

539 ACON

Wiring Diagram for the Pulse-Train Input Type

■ Differential Line Driver Method (ACON-PL)

Max. input pulse frequency : Max. 200 kpps
 Cable Length : Max. 10m

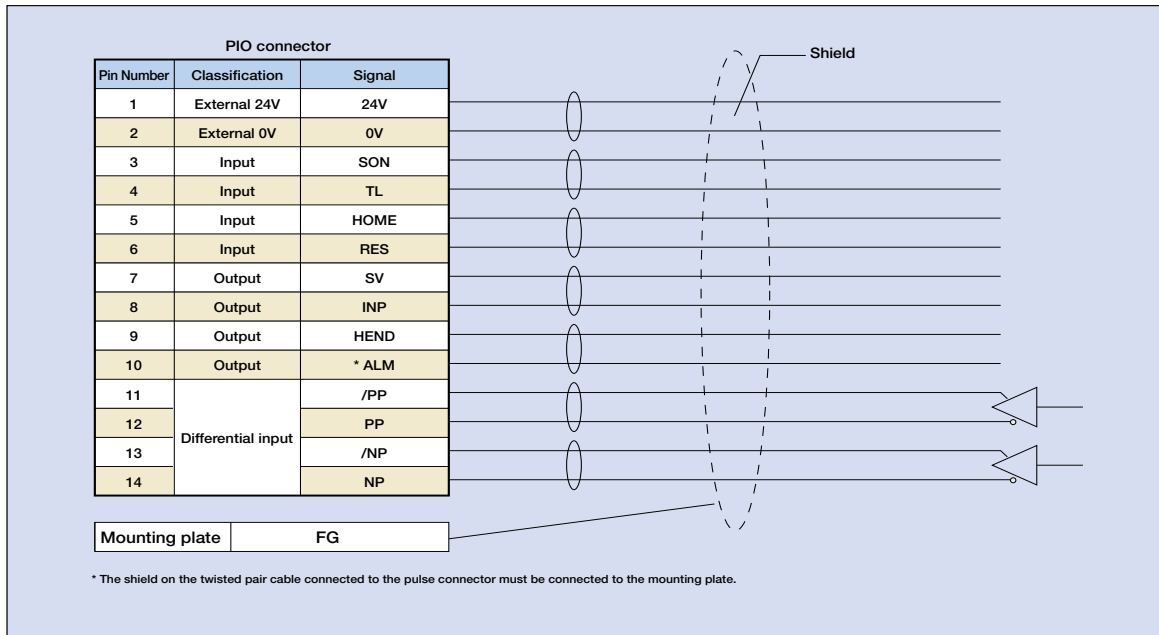

■ Open Collector Method (ACON-PO)

Max. input pulse frequency : Max. 60 kpps
 Cable Length : Max. 2m

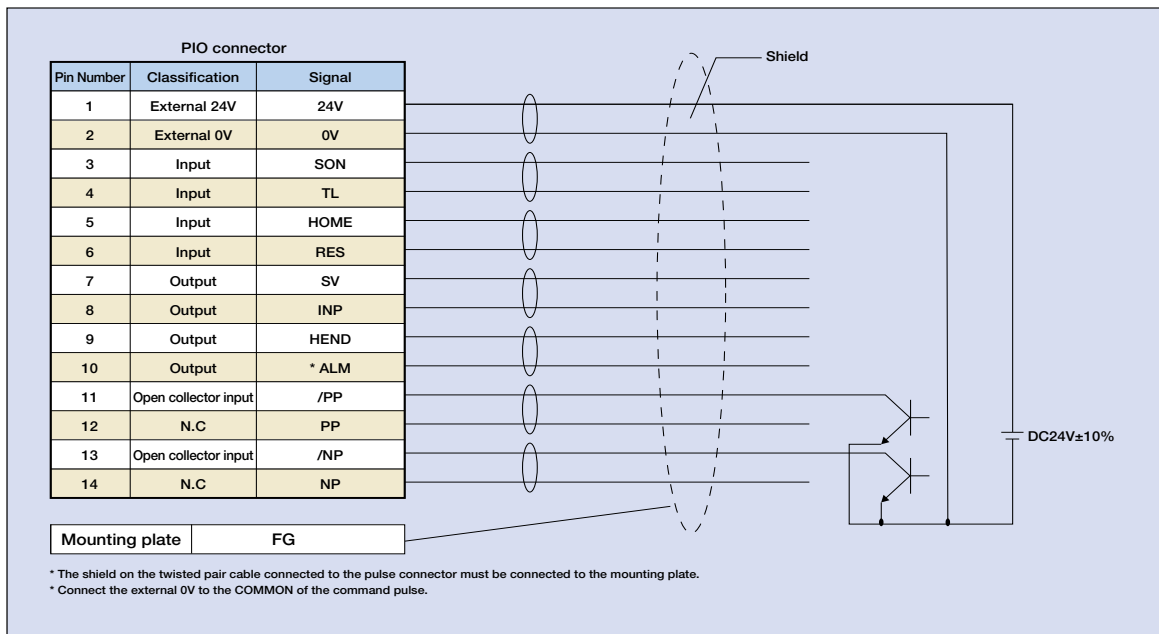

- Slider Type
- Mini
- Standard
- Controllers Integrated
- Pcd Type
- Mini
- Standard
- Controllers Integrated
- Table/Arm /FlatType
- Mini
- Standard
- Gripper/ Rotary Type
- Linear Servo Type
- Cleanroom Type
- Splash-Proo
- Controllers
- PMEC /AMEC
- PSEP /ASEP
- ROBO NET
- ERC2
- PCON
- ACON
- SCON
- PSEL
- ASEL
- SSEL
- XSEL
- Pulse Motor
- Servo Motor (24V)
- Servo Motor (200V)
- Linear Servo Motor

Command Pulse Input State

Command pulse train state		Input terminal	During forward operation	During reversed operation	
Negative logic	Forward pulse train	PP·/PP			
	Reversed pulse train	NP·/NP			
	The forward pulse train causes the motor to rotate forward, and the reverse pulse train causes the motor to rotate in reverse.				
	Pulse train	PP·/PP			
	Symbols	NP·/NP	Low	High	
	The command pulse is used for the amount of motor rotation, and the command symbol is used for rotational direction.				
Positive logic	A/B phase pulse train	PP·/PP			
		NP·/NP			
	An A/B phase pulse with a 90° phase difference (multiplier is 4) is used to generate commands for the amount of rotation and rotational direction.				
	Forward pulse train	PP·/PP			
	Reversed pulse train	NP·/NP			
	Symbols	NP·/NP	High	Low	
A/B phase pulse train	PP·/PP				
	NP·/NP				

Table of specifications

Item	Specifications					
Controller type	C	CG	CY	PL	PO	SE
Connected actuator	RCA Series Actuator					
Number of control axes	1-axis					
Operating method	Positioner type		Solenoid valve type	Pulse train input type		Serial communication type
Positioning Points	512 points		3 points	-		64 points
Backup memory	EEPROM					
I/O connector	40-pin connector		12-pin connector	14-pin connector		None
Number of I/O	16 input points/16 output points		4 input points / 6 output points	4 input points/4 output points		None
I/O power	External supply DC24V±10%					
Serial Communication	RS485 1ch					
Peripheral device communication cable	CB-PAC-PIO □□□		CB-PACY-PIO □□□	CB-PACPU-PIO □□□		CB-RCB-CTL002
Command pulse train input method	-			Differential line driver	Open collector	-
Max. input pulse frequency (Note 1)	-			Max. 200 kpps	Max. 60 kpps	-
Position detection method	Incremental encoder					
Drive-source cutoff relay at emergency stop	Integrated		External			
Forced release of electromagnetic brake	Brake release switch ON/OFF		ON/OFF terminal signal inside the power terminal for brake release			
Input Voltage	DC24V ± 10%					
Dielectric strength voltage	DC500V 1MΩ					
Vibration resistance	XYZ directions		10 to 57Hz, One side amplitude: 0.035mm (continuous), 0.075mm (intermittent) 58 to 150 Hz 4.9 m/s ² (continuous), 9.8 m/s ² (intermittent)			
Ambient operating temperature	0 ~ 40°C					
Ambient operating humidity	10 - 95% (non-condensing)					
Ambient operating atmosphere	Without corrosive gases					
Protection class	IP20					
Weight	Approx. 300g			Approx. 130g		

(Note 1) With the open collector specification, keep the maximum input frequency to 60 kpps or below to prevent malfunction. For applications exceeding 60kpps, use the differential line driver.

Actuator	Motor	Standard specifications/high acceleration and deceleration model		Power-saving model	
		Rated [A]	Max. [A]	Rated [A]	Max. [A]
RCA	10W	1.3	4.4	1.3	2.5
	20W [Model symbol: 20]	1.3	4.4	1.3	2.5
	30W	1.3	4.4	1.3	2.2
RCA2	20W [Model symbol: 20S] SA4, RA3, TA5 Type dedicated	1.7	5.1	1.7	3.4
	RCL	2W	0.8	4.6	
5W		1.0	6.4		
10W		1.3	6.4		

(Note 2) Other than motor power supply capacity, increase 0.5A as control power supply. Inrush current of approx. 5 to 12 times the rated current occurs within 1 to 2 msec from turning the power on. The inrush current changes depending on the power supply line impedance.

541

ACON

External Dimensions

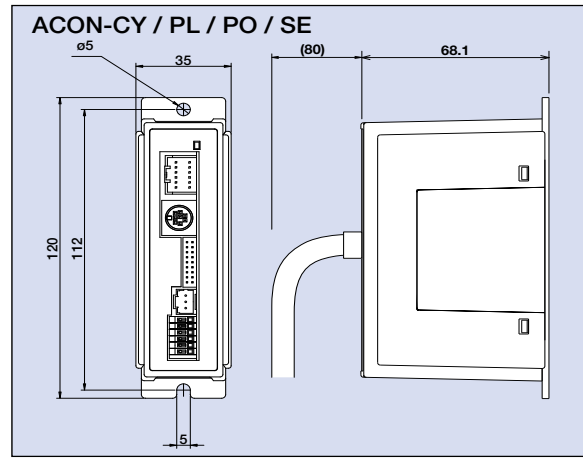
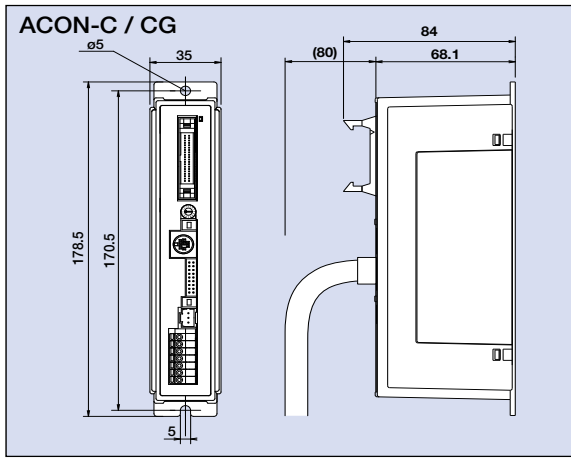

Name of Each Part

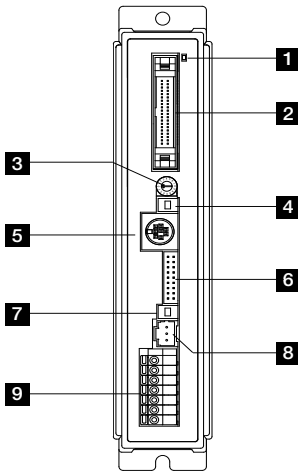

C / CG type

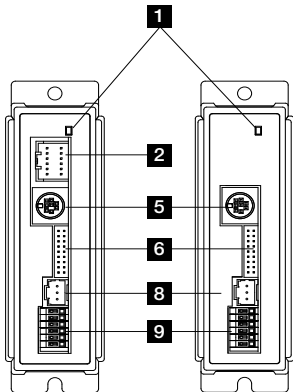

CY/PL/PO Type

SE Type

* PIO connectors are:
CY: 12 pin
PL/PO: 14 pin

1 LED display

These LED colors indicate the condition of the controller.

Lit (green) Servo ON Lit (red) Alarm activated Unlit Servo OFF Blinking (green) Automatic servo-OFF
Emergency stop

2 PIO connector

Connects a cable for communicating with a PLC or other external equipment.

3 Address-setting rotary switch

This switch sets the addresses for controllers used when the unit is linked with controllers.

4 Mode switch

Switches between manual teaching pendant operations (MANU) and automatic operations (AUTO).

Operation details

MANUAL	I/O commands are not accepted. Data can be written from a teaching pendant or PC.
AUTO	I/O commands are valid, while operations from a teaching pendant or PC are not accepted. However, monitoring is possible.

5 SIO connector

Connects a teaching pendant, PC cable, controller, or gateway unit to a controller.

Operation details

Pin No.	Signal	Name	Remarks
1	SGA	Positive side, RS485 differential signal	
2	SGB	Negative side, RS485 differential signal	
3	5V	+5V output	For RS232/485 conversion
4	ENBL	Enable signal	
5	EMGA	EMG line connection to external equipment	
6	24V	24-V power for T/P	For T/P
7	0V	GND	
8	EMGB	EMG line connection to external equipment	
9	0V	EMG line connection to external equipment ground	

6 Encoder brake connector

Connects the encoder/brake cable for the actuator.

7 Brake release switch

This switch forces the brake to release.

8 Motor connector

Connects the motor cable for the actuator.

9 Power terminal block

Main power for controller(s), emergency stop

C / CG type

Terminal number	Signal	Name
7	S1	External drive-source cutoff for TP_EMG terminal
6	S2	TP_EMG terminal
5	MPI	Motor drive-source cutoff terminal
4	MPO	Motor drive-source cutoff terminal
3	24V	Positive side of the 24-V power supply
2	0V	Negative side of the 24-V power supply
1	EMG	EMG signal (application of 24 V)

CY / PL / PO / SE type

Terminal number	Signal	Name
6	BK	BK release
5	MPI	Motor drive-source cutoff terminal
4	MPO	Motor drive-source cutoff terminal
3	24V	Positive side of the 24-V power supply
2	0V	Negative side of the 24-V power supply
1	EMG	EMG signal (application of 24 V)

- Slider Type
- Mini
- Standard
- Controllers Integrated
- Pcd Type
- Mini
- Standard
- Controllers Integrated
- Table/Arm /FlatType
- Mini
- Standard
- Gripper/ Rotary Type
- Linear Servo Type
- Cleanroom Type
- Splash-Proo
- Controllers
- PMEC /AMEC
- PSEP /ASEP
- ROBO NET
- ERC2
- PCON
- ACON
- SCON
- PSEL
- ASEL
- SSEL
- XSEL
- Pulse Motor
- Servo Motor (24V)
- Servo Motor (200V)
- Linear Servo Motor

Option

Teaching Pendant

Features This is a teaching device that provides information on functions such as position input, performing test runs, and monitoring.

- Model** **CON-PT-M-ENG** (Touch panel teaching pendant)
- CON-T-ENG** (Standard type)
- RCM-E-ENG** (Simple teaching pendant)

Configuration

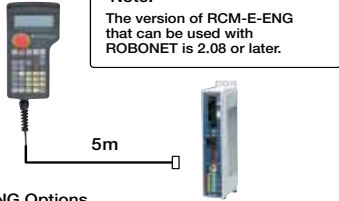

CON-T-ENG Options

- Wall-mounting hook Model HK-1
- Strap Model STR-1

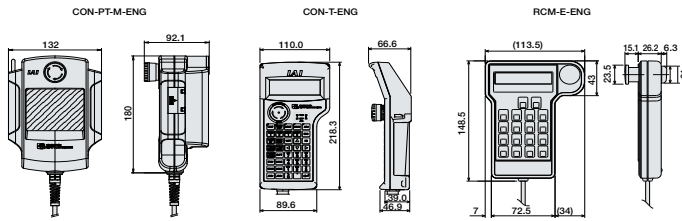

Specifications

Item	CON-PT-M-ENG	CON-T-ENG	RCM-E-ENG
Data Input	○	○	○
Actuator motion	○	○	○
Ambient Operating Temp./Humidity	Temp: 0~40°C; Humidity: 85% RH or below		
Ambient Operating Atmosphere	No corrosive gases. Especially no dust.		
Protection class	IP40	IP54	—
Weight	Approx. 750g	Approx. 400g	Approx. 400g
Cable Length	5m		
Display	3-color LED touch panel with backlight	20 char. x 4 lines LCD display	16 char. x 2 lines LCD display

PC Software (Windows Only)

Features A startup support software for inputting positions, performing test runs, and monitoring. With enhancements for adjustment functions, the startup time is shortened.

- Model** **RCM-101-MW** (External device communications cable + RS232 conversion unit)

Configuration

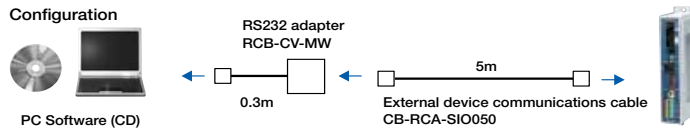

- Model** **RCM-101-USB** (External device communications cable + USB adapter + USB cable)

Configuration

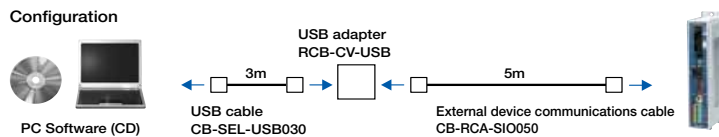

Spare parts

When you need spare parts after purchasing the product, such as when replacing a cable, refer to the list of models below.

Motor Cable for RCA

Model **CB-ACS-MA**

* Enter the cable length (L) into . Compatible to a maximum of 20 meters.
Ex.: 080 = 8 m

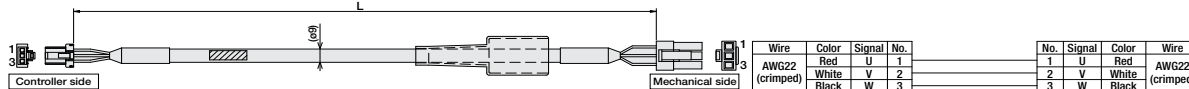

Min. bend radius r = 50 mm or larger (when movable type is used)

543

ACON

Encoder Cable / Encoder Robot Cable for RCA

Model **CB-ACS-PA** / **CB-ACS-PA** -RB

* The standard cable for the encoder cable is the normal cable.
A robot cable can be specified as an option.

* Enter the cable length (L) into . Compatible to a maximum of 20 meters.
Ex.: 080 = 8 m

Min. bend radius $r = 50$ mm or larger (when movable type is used)
* Only robot cable is to be used in a cable track.

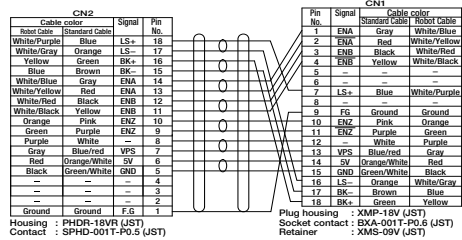
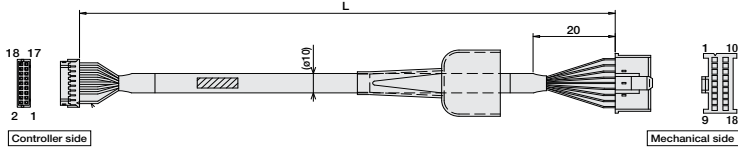

Motor-Encoder Integrated Cable for RCA2

Model **CB-ACS-MPA**

* The standard cable is a robot cable.

* Enter the cable length (L) into . Compatible to a maximum of 20 meters.
Ex.: 080 = 8 m

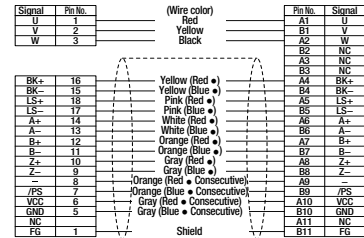
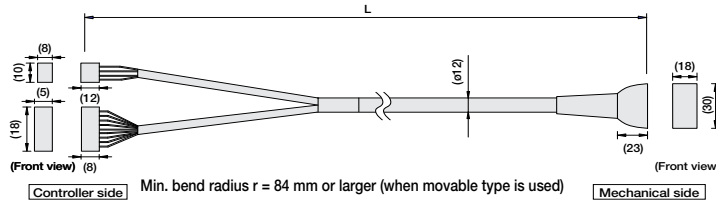

I/O Flat Cable (for ACON-C / CG)

Model **CB-PAC-PIO**

* Enter the cable length (L) into . Compatible to a maximum of 10 meters.
Ex.: 080 = 8 m

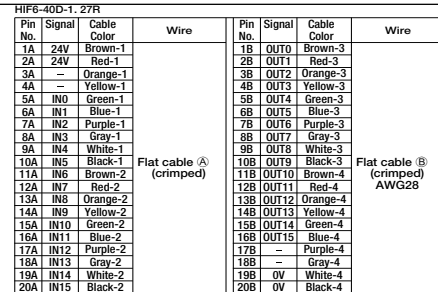
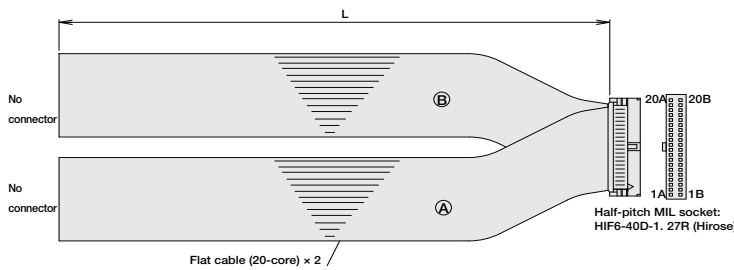

I/O Cable for Solenoid Valve Type (for ACON-CY)

Model **CB-PACY-PIO**

* Enter the cable length (L) into . Compatible to a maximum of 10 meters.
Ex.: 080 = 8 m

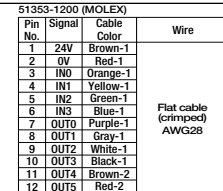
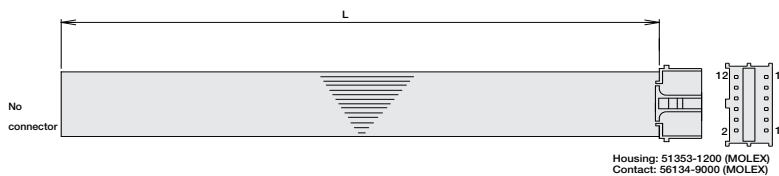

Pulse Train Control I/O Cable (for ACON-PL/PO)

Model **CB-PACPU-PIO**

* Enter the cable length (L) into . Compatible to a maximum of 10 meters.
Ex.: 080 = 8 m

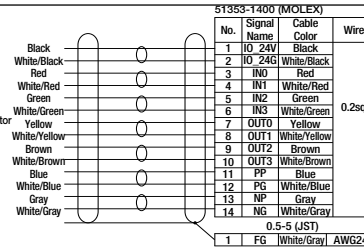
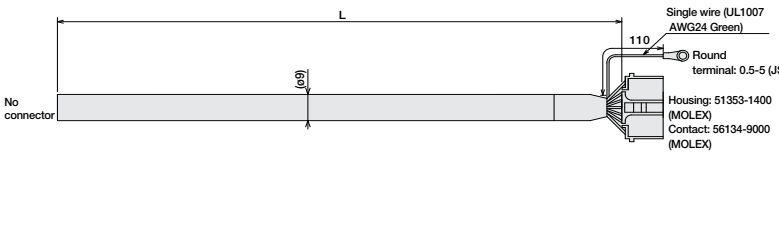

ACON 544

- Slider Type
- Mini
- Standard
- Controllers Integrated
- Pcd Type
- Mini
- Standard
- Controllers Integrated
- Table/Arm /FlatType
- Mini
- Standard
- Controllers Integrated
- Gripper/ Rotary Type
- Linear Servo Type
- Cleanroom Type
- Splash-Proof
- Controllers
- PMEC /AMEC
- PSEP /ASEP
- ROBO NET
- ERC2
- PCON
- ACON
- SCON
- PSEL
- ASEL
- SSEL
- XSEL
- Pulse Motor
- Servo Motor (24V)
- Servo Motor (200V)
- Linear Servo Motor

- Slider Type
- Mini
- Standard
- Controllers Integrated
- Rod Type
- Mini
- Standard
- Controllers Integrated

PCON-ABU ACON-ABU



Simple absolute unit
For PCON / ACON controller

- Table/Arm /FlatType
- Mini
- Standard

Features

1

When attached to a ACON/PCON-C, -CG, -CY, or -SE (incremental) controller, the data from the encoder is retained even after the controller's main power has been turned OFF, allowing you to use it as an absolute model, which does not require homing at power-up.

* Cannot be used for ACON/PCON-PL or PO types.

Caution:

The encoder type for the actuators and controllers with a simple absolute unit is "I" (incremental) and not "A" (absolute).

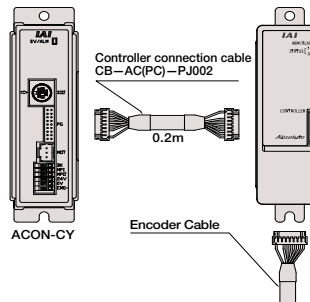

- Gripper/ Rotary Type
- Linear Servo Type
- Cleanroom Type
- Splash-Proof

2

Having the same size as the CY and SE compact controllers (W 34mm x H 100mm x D 75.3mm), it can be installed in a small space.

3

Encoder data can be retained up to 20 days.

Caution:

An error will occur if the actuator's slider or rod is moved faster than the fixed speed, while the encoder data is retained. Check the specifications table on page 546 for the allowable speed (rotations).

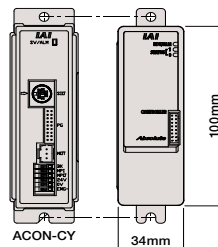

- Controllers
- PMEC /AMEC
- PSEP /ASEP
- ROBO NET
- ERC2
- PCON
- ACON
- SCON
- PSEL
- ASEL
- SSEL
- XSEL

Models

	For PCON controller	For ACON controller
Model	PCON-ABU	ACON-ABU

Connectable actuator

The simple absolute unit is available for the following actuators. (Models other than following models are not available.)

Corresponding series	Reference
RCP3 series	Corresponding to all models
RCP2 series	Corresponding to all models other than HS8C/HS8R/RA10C.
RCP2 CR series	Corresponding to all models other than HS8C.
RCP2 W series	Corresponding to all models other than SA16C/RA10C.
RCA2 series	Corresponding to all models
RCA series	Corresponding to all models
RCA CR series	Corresponding to all models
RCA W series	Corresponding to all models

- Pulse Motor
- Servo Motor (24V)
- Servo Motor (200V)
- Linear Servo Motor

545 PCON-ABU/ACON-ABU

Specifications

Item	Details			
Model	ACON-ABU		PCON-ABU	
	ACON - C / CG / CY / SE		PCON - C / CG / CY / SE	
Connecting controller	(Caution) When choosing a controller to connect with the simple absolute unit, add "-ABU" to the end of the controller model designation. Ex. ACON - C 20I - NP - 2 - 0 - ABU			
Connecting actuator	RCA2 / RCA series		RCP3/RCP2 series (*1)	
Controller connection cable (included accessory)	Model CB - AC - PJ002 (0.2m)		Model CB - PC - PJ002 (0.2m)	
Simple absolute unit	Model ABU			
Backup battery (included accessory)	Model AB - 7 (Ni - MH battery / Life: approx. 3 years)			
Power supply voltage	DC24V±10%			
Power supply current	Max. 300 mA			
Ambient operating temperature	0 to 40°C (approx. 20°C is preferred)			
Ambient operating humidity	95% RH or lower (non-condensing)			
Ambient operating atmosphere	Without corrosive gases, without dust			
Weight	330g			
Allowable encoder RPM during data retention (*2)	800 rpm	400 rpm	200 rpm	100 rpm
Position data retaining time (*2)	120h	240h	360h	480h

(*1) Cannot be used with RCP2-RA10C/HS8C/HS8R/RCP2W-SA16C

(*2) Position data retention time changes with the allowable encoder RPMs during data retention.

(800rpm → 120h / 400rpm → 240h / 200rpm → 360h / 100rpm → 480h)

External dimensions

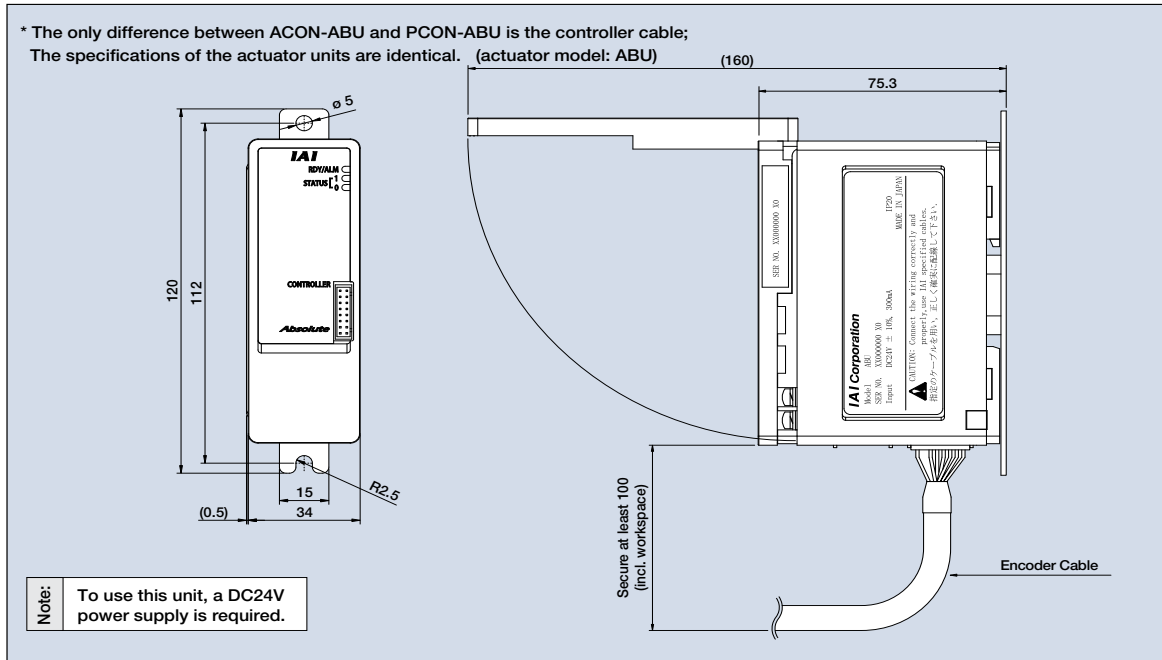

- Slider Type
- Mini
- Standard
- Controllers Integrated
- Fcd Type
- Mini
- Standard
- Controllers Integrated
- Table/Arm /FlatType
- Mini
- Standard
- Gripper/ Rotary Type
- Linear Servo Type
- Cleanroom Type
- Splash-Proof
- Controllers
- PMEC /AMEC
- PSEP /ASEP
- ROBO NET
- ERC2
- PCON
- ACON
- SCON
- PSEL
- ASEL
- SSEL
- XSEL
- Pulse Motor
- Servo Motor (24V)
- Servo Motor (200V)
- Linear Servo Motor

- Slider Type
- Mini
- Standard
- Controllers Integrated
- Rod Type
- Mini
- Standard
- Controllers Integrated
- Table/Arm /FlatType
- Mini
- Standard
- Gripper/ Rotary Type
- Linear Servo Type
- Cleanroom Type
- Splash-Proof
- Controllers
- PMEC /AMEC
- PSEP /ASEP
- ROBO NET
- ERC2
- PCON
- ACON
- SCON
- PSEL
- ASEL
- SSEL
- XSEL
- Pulse Motor
- Servo Motor (24V)
- Servo Motor (200V)
- Linear Servo Motor



Position Controller For RCS2 Series

List of models

There are 2 types of SCON controllers: standard specifications in which operation is performed via PIO or pulse train input, and network specifications for operation via connection to a field network. Incremental specifications and absolute specifications are available for both types. However, only incremental specified operations are available when operating via the pulse train input.

Type	C								
Name	Standard				Network connection specifications (optional)				
External View									
Description	Positioning mode, Teaching mode Solenoid Valve Mode		Pulse train mode	DeviceNet Connection specifications		CC-Link Connection specifications		ProfiBus Connection specifications	
Position points	Max. 512 points		(-)			Max. 512 points			
I/O type symbol	NP/PN			DV		CC		PR	
Compatible encoder	Incremental	Absolute	Incremental	Incremental	Absolute	Incremental	Absolute	Incremental	Absolute

*Always use a noise filter for power supplies.
(See P548)

(Caution) Note that with the network specifications, neither control via pulse train nor PIO is available.

Model

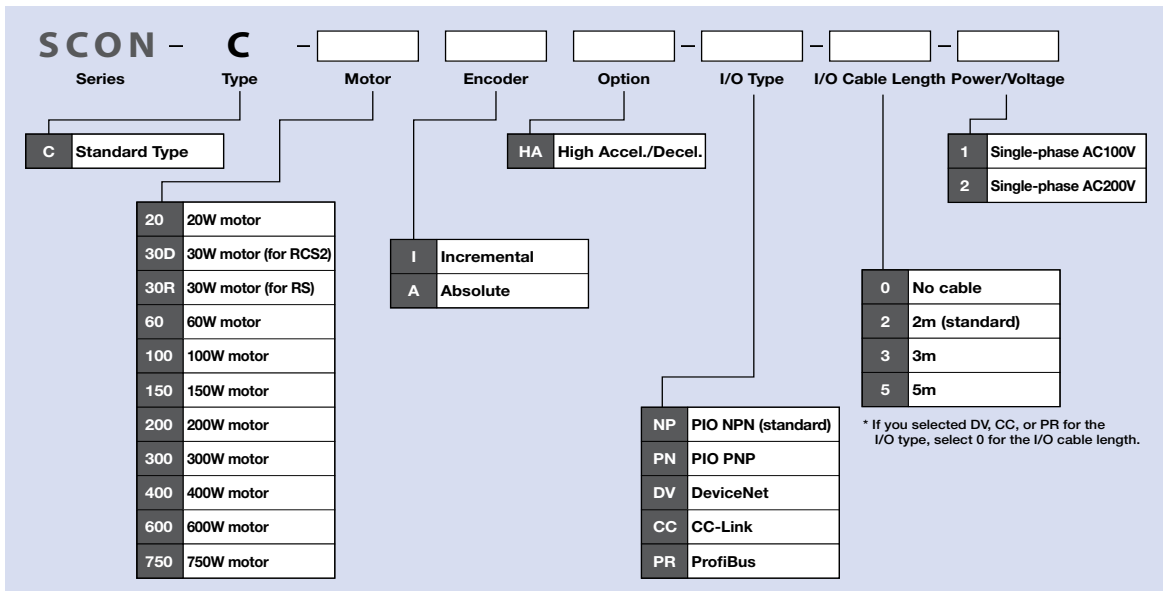

547

SCON

System configuration

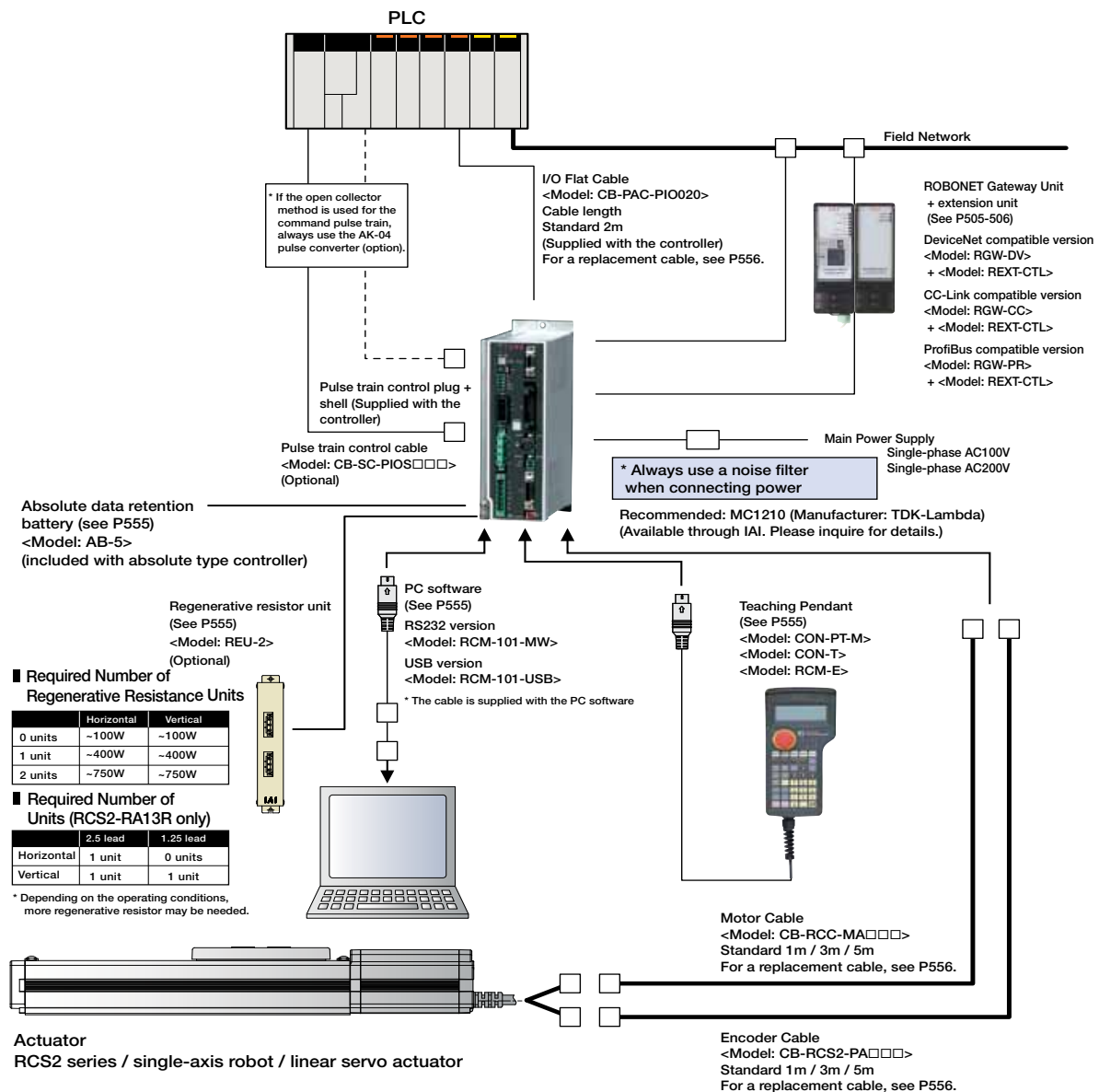

Pulse converter AK-04 (option)

Description: Pulse converter (model: AK-04) + I/O e-CON connector
Use this converter if output pulses from the host controller are of open collector specification. This converter is used to convert the open-collector command output pulses from the host controller to differential pulses. Converting open collector pulses to differential pulses improves noise resistance. Two phases of differential pulses equivalent to those from the line driver 26C31 are output. The e-CON connector is used as an input/output connector to simplify the field wiring.

Basic Specifications

- Input power : DC24V±10% (Max. 50mA)
- Input pulse : Open collector (collector current Max. 12mA)
- Input frequency : 200 kHz or less
- Output pulse : 26C31 equivalent differential output (Max. 10mA)
- External dimensions : See the figure at right (cable connector not included)
- Weight : 10g or less (cable connector not included)
- Accessories : I/O e-CON connector
3M 37104-3122-000FL

(Applicable wire: AWG No. 24 to 26, 0.14 to less than 0.3mm²)
Outer diameter of finished wire 1.0 to 1.2mm)

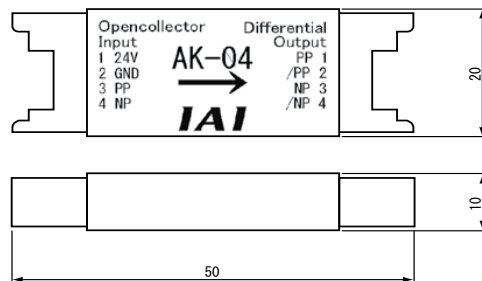

- Slider Type
- Mini
- Standard
- Controllers Integrated
- Pcd Type
- Mini
- Standard
- Controllers Integrated
- Table/Arm /FlatType
- Mini
- Standard
- Gripper/ Rotary Type
- Linear Servo Type
- Cleanroom Type
- Splash-Proof
- Controllers
- PMEC /AMEC
- PSEP /ASEP
- ROBO NET
- ERC2
- PCON
- ACON
- SCON
- PSEL
- ASEL
- SSEL
- XSEL

- Pulse Motor
- Servo Motor (24V)
- Servo Motor (200V)
- Linear Servo Motor

I/O Specifications

Input section External input specifications

Item	Specifications
Input voltage	DC24V ±10%
Input current	4mA / 1 point
ON/OFF power supply	ON voltage...Min DC18.0V (3.5mA) ON voltage...Max DC6.0V (1mA)
Isolation method	Photocoupler

NPN Specifications

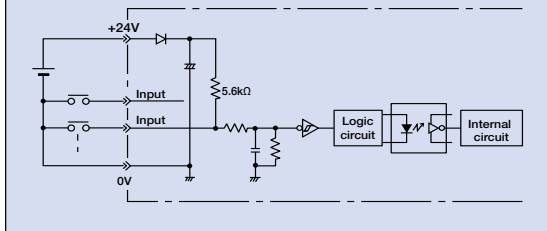

Output section External output specifications

Item	Specifications
Load Voltage	DC24V
Max. load current	100mA / 1 point 400mA / 8 points
Leak current	Max 0.1mA / 1 point
Isolation method	Photocoupler

NPN Specifications

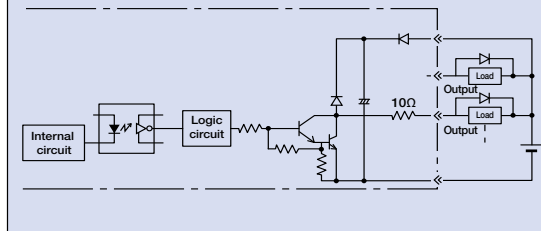

PNP Specifications

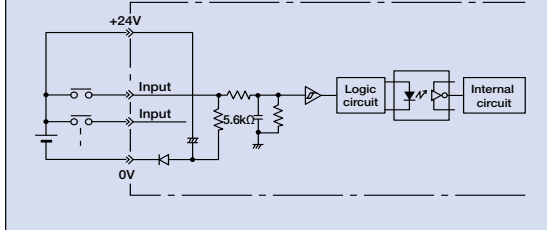

PNP Specifications

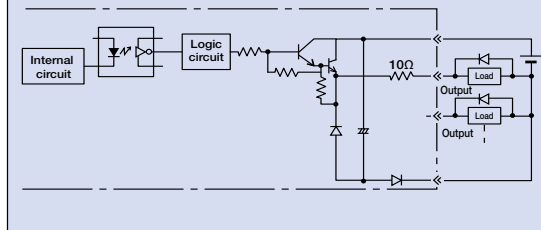

Explanation of I/O Signal Functions

SCON-C is compatible with all of the following control methods.

Positioning is possible with up to 512 points in positioner mode and up to 7 points in solenoid valve mode.

Control Function by Type

Type	SCON-C	Features
Positioner mode	○	This is the basic operating mode, in which the user designates position numbers and inputs start signals.
Teaching mode	○	In this mode, it is possible to move the slide (rod) via external signal, and then register the stop position as position data.
Solenoid valve mode	○	The actuator can be moved simply by ON/OFF of position signals. This mode supports the same control signals you are already familiar with on solenoid valves of air cylinders.
Pulse train mode	○	In this mode, you can operate the actuator freely using pulse trains without inputting position data.
Network compatible	○	If the optional network specifications are selected, direct connection to a field network is possible.

CAUTION

Note that for network compatible types, PIO and pulse train communication are not available.

549

SCON

Explanation of I/O Signal Functions

The table below explains the functions allocated to the controller's I/O signal.

Since the signals that can be used vary depending on the controller type and settings, check the signal table for each controller to confirm the available functions.

■ Signal Function Description

Classification	Signal abbreviations	Signal	Function description
Input	CSTR	Start signal	Input this signal to cause the actuator to start moving to the position set by the command position number signal.
	PC1 to PC256	Command position number signal	This signal is used to input a target position number (binary input).
	BKRL	Brake forced release signal	This signal forcibly releases the brake.
	RMOD	Running mode switching signal	Operations mode can be switched when the controller's MODE switch is set to AUTO. (AUTO if this signal is OFF, MANU if the signal is ON)
	* STP	Pause signal	Turning this signal OFF causes the moving actuator to decelerate to a stop. The actuator will resume the remaining movement if the signal is turned ON during the pause.
	RES	Reset signal	Turning this signal ON resets the alarms that are present. If this signal is turned ON while the actuator is paused (*STP is OFF), the remaining movement can be cancelled.
	SON	Servo ON signal	The servo remains on while this signal is ON, or off while the signal is OFF.
	HOME	Home return signal	Turning this signal ON preforms home-return operation.
	MODE	Teaching mode signal	Turning this signal ON switches the controller to the teaching mode (provided that CSTR, JOG+ and JOG- are all OFF and the actuator is not moving)
	JISL	JOG/INCHING switching signal	When the main signal is off, the JOG operation will be conducted for JOG+ and JOG-. When the signal is on, the unit will do the inching operation for JOG+ and JOG-.
	JOG+, JOG-	JOG signal	When the JISL signal is OFF and the JOG +/- signal turns ON, the unit will jog in the + (positive) direction when the JOG + turns on and the - (negative) direction when the JOG - turns on. During the JOG operation, the unit slows to a stop when the JOG +/- signal turns off.
	PWRT	Teaching signal	In the teaching mode, specify a desired position number and then turn this signal ON for at least 20ms to write the current position to the specified position number.
	ST0 to ST6	Start position command signal	Turning this signal ON in the solenoid valve mode causes the actuator to move to the specified position. (Start signal is not required)
	TL	Torque limit selection signal	While this signal is ON, torque is limited by the value set by a parameter. The TLM signal turns on if torque has reached the specified value.
	CSTP	Forced Stop Signal	Servo OFF is performed when this signal is ON for more than 10ms.
DCLR	Deviation counter clear signal	When this signal is ON, the position deviation counter is cleared continuously.	
Output	PEND/INP	In position signal	This signal turns ON when the actuator has entered the positioning band after movement. If the actuator has exceeded the positioning band, PEND does not turn OFF, but INP does. PEND and INP can be swapped using a parameter.
	PM1 to PM256	Positioning complete signal	This signal is used to output the position number achieved at completion of positioning (binary output)
	HEND	Home return completion signal	This signal turns ON upon completion of home return.
	ZONE1	Zone signal	Turns ON if the actuator's current position is within the range set by the parameter.
	PZONE	Position zone signal	This signal turns ON when the current actuator position has entered the range specified by position data during position movement. PZONE can be used together with ZONE1, but PZONE is valid only during movement to a specified position.
	RMDS	Running mode status signal	This outputs the operation mode status.
	* ALM	Controller alarm status signal	Turns ON when the controller is in normal condition, and turns OFF when an alarm occurs.
	MOVE	Moving signal	Turns ON while the actuator is moving (home return), including when there is push force.
	SV	Servo ON status signal	This signal turns ON when servo is ON.
	* EMGS	Emergency stop status signal	This signal remains ON while the controller is not in the emergency stop mode, and turns OFF once an emergency stop has been actuated.
	* BALM	Absolute battery voltage drop warning signal	With the absolute specifications for the controller, turns OFF when the absolute battery voltage drops.
	MODES	Mode status signal	The mode signal input turns it ON when it goes into teaching mode. It turns OFF when it goes into normal mode.
	WEND	Writing complete signal	This signal remains OFF after the controller has switched to the teaching mode. It turns ON upon completion of data write using the PWRT signal. If the PWRT signal is turned Off, this signal also turns OFF.
	PE0 to PE6	Current position number signal	This signal turns ON after the controller has completed moving to the target position in the solenoid valve mode.
	PWR	System Ready Signal	Turns ON when it starts up normally after turning ON the controller. (Dedicated pulse train type)
	TLR	Torque limiting signal	This signal turns ON once the motor torque has reached the specified value in a condition where torque is being limited by the TL signal. (Dedicated pulse train mode)
	ALM1 to ALM8	Alarm Code Output Signal	During a controller alarm, the alarm details are output in code. (Dedicated pulse train mode)
LSO to LS2	Limit switch output signal	Each signal turns ON when the current actuator position has entered the positioning band before or after the target position. If the actuator has already completed home return, these signals are output even before a movement command is issued or while the servo is OFF.	

(Note) Signals with asterisks (*) are normally ON and OFF during operation.

- Slider Type
- Mini
- Standard
- Controllers Integrated
- Pcd Type
- Mini
- Standard
- Controllers Integrated
- Table/Arm /FlatType
- Mini
- Standard
- Gripper/ Rotary Type
- Linear Servo Type
- Cleanroom Type
- Splash-Proo
- Controllers
- PMEC /AMEC
- PSEP /ASEP
- ROBO NET
- ERC2
- PCON
- ACON
- SCON
- PSEL
- ASEL
- SSEL
- XSEL
- Pulse Motor
- Servo Motor (24V)
- Servo Motor (200V)
- Linear Servo Motor

I/O wiring drawing

Positioning mode / teaching mode / solenoid valve mode

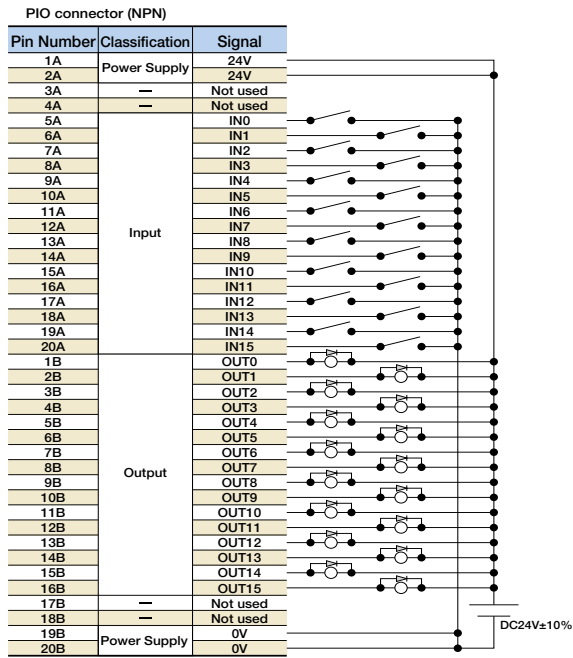

* Connect 24V between pins 1A and 2A, and 0V between pins 19B and 20B.

Pulse train mode (differential output)

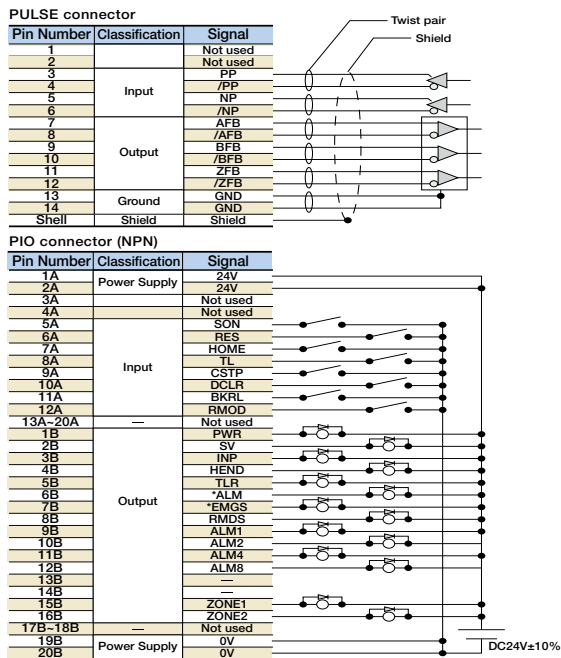

* The shield on the twisted pair cable connected to the pulse connector must be connected to the shell.
Also, the cable length must not be longer than 10m.

* Connect 24V between pins 1A and 2A, and 0V between pins 19B and 20B.

I/O Signal Table *Choose from 7 types of signal allocation.

Pin Number	Classification	Number of Positions Zone Signal P-zone Signal	Parameter Selections (PIO Patterns)							Pulse Train Mode
			0	1	2	3	4	5	0	
			Positioning mode 64 points	Teaching Mode 64 points	256-point Mode 256 points	512-point Mode 512 points	Solenoid Valve Mode 1 7 points	Solenoid Valve Mode 2 3 points	Pulse Train Mode	
1A	24V									P24
2A	24V									P24
3A	—									NC
4A	—									NC
5A	Input	IN0	PC1	PC1	PC1	PC1	ST0	ST0		SON
6A		IN1	PC2	PC2	PC2	PC2	ST1	ST1 (JOG+)		RES
7A		IN2	PC4	PC4	PC4	PC4	ST2	ST2 (-)		HOME
8A		IN3	PC8	PC8	PC8	PC8	ST3			TL
9A		IN4	PC16	PC16	PC16	PC16	ST4			CSTP
10A		IN5	PC32	PC32	PC32	PC32	ST5			DCLR
11A		IN6	—	MODE	PC64	PC64	ST6			BKRL
12A		IN7	—	JISL	PC128	PC128				RMOD
13A		IN8	—	JOG+	—	PC256				—
14A		IN9	BKRL	JOG-	BKRL	BKRL	BKRL	BKRL	BKRL	—
15A		IN10	RMOD	RMOD	RMOD	RMOD	RMOD	RMOD	RMOD	—
16A		IN11	HOME	HOME	HOME	HOME	HOME	HOME	HOME	—
17A		IN12	* STP	* STP	* STP	* STP	* STP	* STP	* STP	—
18A		IN13	CSTR	CSTR/PWRT	CSTR	CSTR				—
19A		IN14								—
20A	IN15	RES	RES	RES	RES	RES	RES	RES	—	
1B	Output	OUT0	PM1	PM1	PM1	PM1	PE0	LSO		PWR
2B		OUT1	PM2	PM2	PM2	PM2	PE1	LS1 (TRQS)		SV
3B		OUT2	PM4	PM4	PM4	PM4	PE2	LS2		INP
4B		OUT3	PM8	PM8	PM8	PM8	PE3			HEND
5B		OUT4	PM16	PM16	PM16	PM16	PE4			TLR
6B		OUT5	PM32	PM32	PM32	PM32	PE5			* ALM
7B		OUT6	MOVE	MOVE	PM64	PM64	PE6			* EMGS
8B		OUT7	ZONE1	MODES	PM128	PM128	ZONE1	ZONE1		RMDS
9B		OUT8	PZONE	PZONE	PZONE	PM256	PZONE	PZONE		ALM1
10B		OUT9	RMDS	RMDS	RMDS	RMDS	RMDS	RMDS		ALM2
11B		OUT10	HEND	HEND	HEND	HEND	HEND	HEND		ALM4
12B		OUT11	PEND	PEND/WEND	PEND	PEND	PEND			ALM8
13B		OUT12	SV	SV	SV	SV	SV			—
14B		OUT13	* EMGS	* EMGS	* EMGS	* EMGS	* EMGS	* EMGS		—
15B		OUT14	* ALM	* ALM	* ALM	* ALM	* ALM	* ALM		ZONE1
16B	OUT15	* BALM	* BALM	* BALM	* BALM	* BALM	* BALM		ZONE2	
17B	—								—	
18B	—								—	
19B	0V					N			N	
20B	0V					N			N	

* The names of signals above, the values enclosed in () are functions before homing is performed.
* The signals with an asterisk are normally ON, and OFF during operation.

551

SCON

Pulse Train Type I/O Specifications (differential line driver specifications)

Input Section

Max. No. of : Line-driver interface: 500kpps
 Input Pulses : Open collector interface: 200kpps (AK-04 required)
 Isolation method : Photocoupler

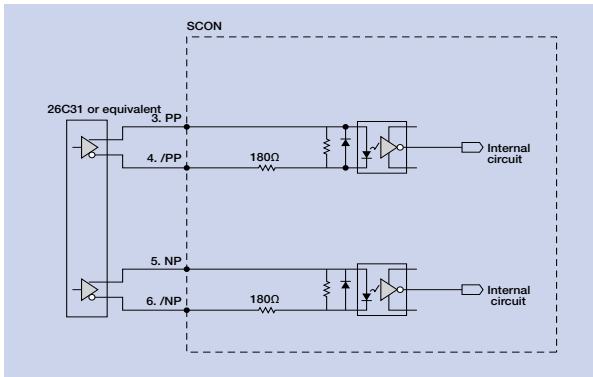

Output Section

Output method : Line-driver output
 Isolation : Not isolated

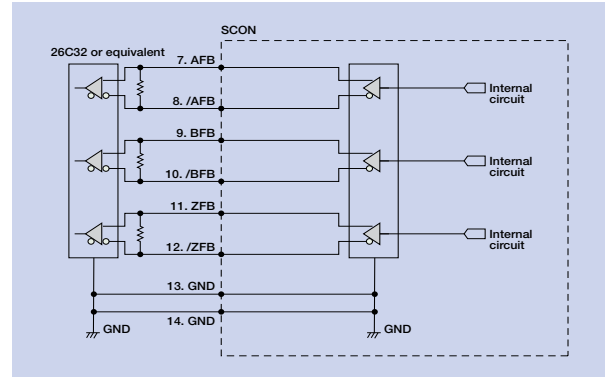

Pulse Train Type I/O Specifications (open collector specifications)

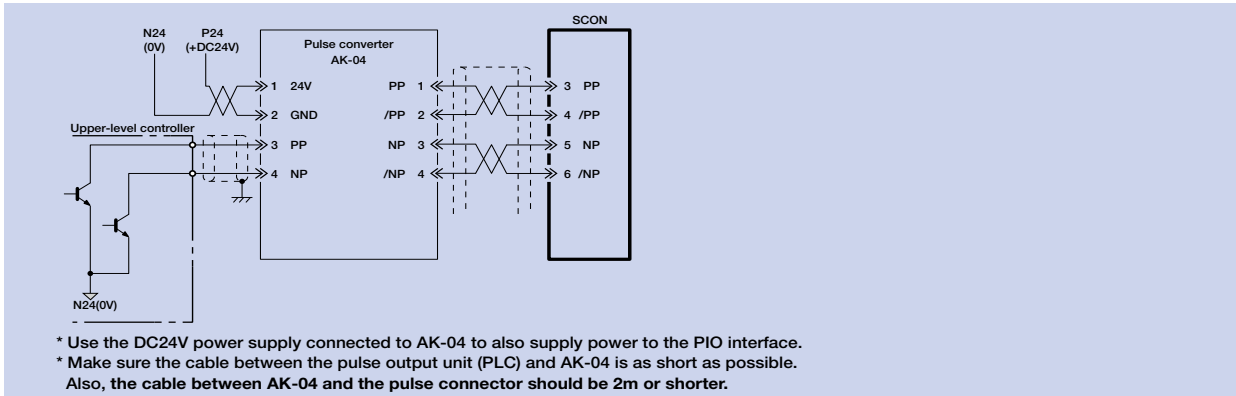

Command Pulse Input State

Command Pulse Train Shapes		Input terminals	Forward	Reverse	
Negative Logic	Forward pulse train	PP, /PP			
	Reverse pulse train	NP, /NP			
	The forward pulse train controls the amount of forward motor rotation; the reverse pulse train controls the same in reverse direction.				
	Pulse train	PP, /PP			
	Sign	NP, /NP	Low	High	
The command pulse controls the amount of motor rotation, and the command sign controls the direction of rotation.					
Positive Logic	A/B phase pulse train	PP, /PP NP, /NP			
	A (frequency-quadrupled) A/B phase pulse with a 90° phase difference is used to control the amount and direction of rotation.				
	Forward pulse train	PP, /PP			
	Reverse pulse train	NP, /NP			
	Sign	NP, /NP	High	Low	

- Slider Type
- Mini
- Standard
- Controllers Integrated
- Pcd Type
- Mini
- Standard
- Controllers Integrated
- Table/Arm /FlatType
- Mini
- Standard
- Gripper/ Rotary Type
- Linear Servo Type
- Cleanroom Type
- Splash-Proo
- Controllers
- PMEC /AMEC
- PSEP /ASEP
- ROBO NET
- ERC2
- PCON
- ACON
- SCON
- PSEL
- ASEL
- SSEL
- XSEL
- Pulse Motor
- Servo Motor (24V)
- Servo Motor (200V)
- Linear Servo Motor

Table of specifications

Item	Specifications	
Motor Capacity	Less than 400W	400W or more
Connected actuator	RCS2 series actuator / single axis robot / linear servo actuator	
Number of control axes	1-axis	
Operating method	Positioner type / pulse train type	
Positioning Points	512 points	
Backup memory	EEPROM	
I/O connector	40 pin connector	
Number of I/O	16 input points / 16 output points	
I/O power	External supply DC24V±10%	
Serial Communication	RS485 1ch	
Field Network	Device Net, CC-Link, ProfiBus	
Peripheral device communication cable	CB-PAC-PIO □□□	
Command pulse train input method	Differential line driver method / open collector method (converted to differential with the pulse converter *1)	
Max. input pulse frequency	Differential line driver method: up to 500 kpps / open collector method (using pulse converter): up to 200kpps	
Position detection method	Incremental encoder / Absolute encoder	
Emergency stop function	Y (integrated relay)	
Electromagnetic brake forced release	Brake release switch ON/OFF	
Input Voltage	Single-phase AC90V to AC126.5V Single-phase AC180V to AC253V	Single-phase AC180V to AC253V
Power Supply Capacity	20W / 74VA 30W / 94VA 60W / 186VA 100W / 282VA 150W / 376VA 200W / 469VA	400W / 844VA 600W / 1212VA 750W / 1569VA
Dielectric strength voltage	DC500V 100MΩ or more	
Vibration resistance	XYZ directions 10 to 57Hz, One side amplitude: 0.035mm (continuous), 0.075mm (intermittent) 58 to 150 Hz 4.9 m/s ² (continuous), 9.8 m/s ² (intermittent)	
Ambient operating temperature	0-40°C	
Ambient operating humidity	10 - 95% (non-condensing)	
Ambient operating atmosphere	Without corrosive gases	
Protection class	IP20	
Weight	Approximately 800g (plus 25g for the absolute specifications)	Approximately 1.1kg (plus 25g for absolute specifications)
External dimension	58mm(W)×194mm(H)×121mm(D)	72mm(W)×194mm(H)×121mm(D)

(Note 1) For the command-pulse input method, use the differential line driver method offering higher noise resistance.
If the open collector method must be used, convert the pulse to differential using the optional pulse converter (AK-04).

- Slider Type
- Mini
- Standard
- Controllers Integrated
- Pod Type
- Mini
- Standard
- Controllers Integrated
- Table/Arm /FlatType
- Mini
- Standard
- Gripper/ Rotary Type
- Linear Servo Type
- Cleanroom Type
- Splash-Proof
- Controllers
 - PMEC /AMEC
 - PSEP /ASEP
 - ROBO NET
 - ERC2
 - PCON
 - ACON
 - SCON**
 - PSEL
 - ASEL
 - SSEL
 - XSEL
- Pulse Motor
- Servo Motor (24V)
- Servo Motor (200V)
- Linear Servo Motor

553

SCON

External dimensions

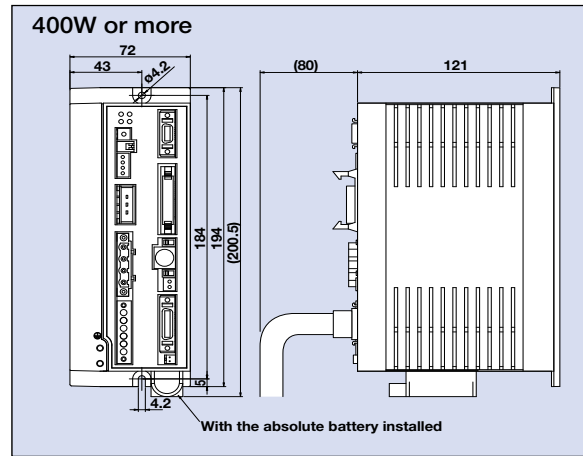
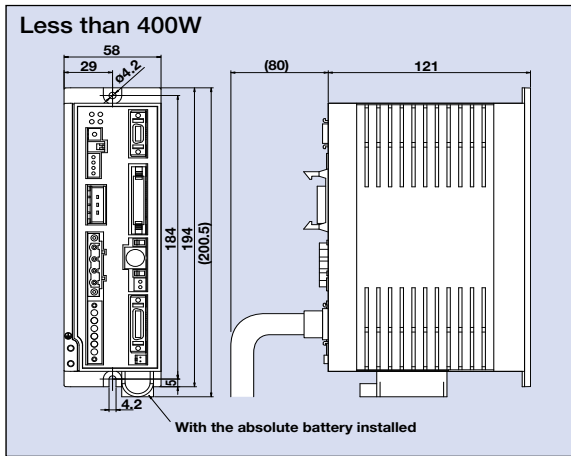

Name of Each Part

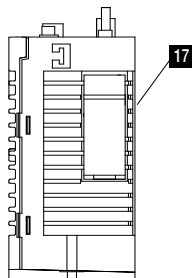
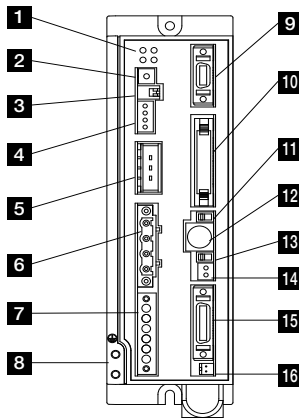

1 LED display

These LED colors indicate the condition of the controller.

Name	Color	Explanation
PWR	Green	Lit when the system is ready (after power is ON, CPU normal functions)
SV	Green	Lit when servo is ON
ALM	Orange	Lit during an alarm
EMG	Red	Lit during an emergency stop

2 Rotary switch

This is the address setting switch for identifying each controller when they are linked.

3 Piano switch

Controller system switch.

Name	Explanation
1	Operating mode switch OFF: positioner mode ON: pulse train control mode *Enabled at power ON.
2	Remote update switch (normally set to OFF) OFF: normal operating mode ON: update mode *Enabled when power is ON or during soft reset.

4 System I/O connector

Connector for the emergency stop switch etc.

5 Regeneration unit connector

Connector for resistance unit that absorbs regeneration current produced when the actuator decelerates to a stop.

6 Motor connector (X-SEL, ECON, RCS compatible)

Actuator motor cable connector.

7 Power supply connector

AC power connector. Divided into the control power input and motor power input.

8 Grounding screw

Protective grounding screw. Always ground this screw.

9 Pulse train control connector

This connector is used during pulse train control mode operations. It is disconnected during operations in positioner mode.

10 PIO connector

Connector for the cable for parallel communications with the PLC and other peripheral devices.

11 Operating mode switch

Name	Explanation
MANU	Do not receive PIO commands
AUTO	Accept PIO commands

*The emergency stop switch on the teaching pendant becomes effective when the line is connected, regardless of whether this switch is set to AUTO or MANU. Take note that an emergency stop will be actuated momentarily when the teaching-pendant or SIO communication cable is disconnected. This is a normal phenomenon and does not indicate an error.

12 SIO connector

Connector for the teaching pendant or PC communications cable.

13 Brake release switch

This is the electromagnetic brake forced release switch, integrated with the actuator.

*It is necessary to connect the DC 24V power for the brake drive.

14 Brake power connector

Brake power DC 24V supply connector (only required when the brake equipped actuator is connected)

15 Encoder sensor connector (X-SEL-P/Q compatible)

Encoder sensor cable connector

16 Absolute battery connector

Connector for the absolute data backup battery. (Required only for absolute encoder specifications)

17 Absolute battery holder

Battery holder for installing the absolute data backup battery

- Slider Type
- Mini
- Standard
- Controllers Integrated
- PCd Type
- Mini
- Standard
- Controllers Integrated
- Table/Arm /FlatType
- Mini
- Standard
- Gripper/ Rotary Type
- Linear Servo Type
- Cleanroom Type
- Splash-Proof
- Controllers
- PMEC /AMEC
- PSEP /ASEP
- ROBO NET
- ERC2
- PCON
- ACON
- SCON
- PSEL
- ASEL
- SSEL
- XSEL
- Pulse Motor
- Servo Motor (24V)
- Servo Motor (200V)
- Linear Servo Motor

Option

Teaching Pendant

Features This is a teaching device that provides information on functions such as position input, test runs, and monitoring.

Model
CON-PT-M-ENG (Touch panel teaching pendant)
CON-T-ENG (Standard type)
RCM-E-ENG (Simple teaching pendant)

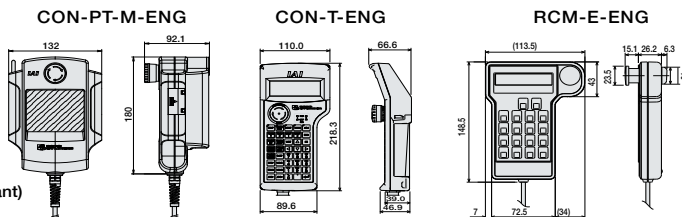

Configuration

Note:
 The version of RCM-E-ENG that can be used with ROBONET is 2.08 or later.

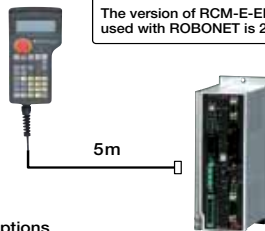

CON-T Options

- Wall-mounting hook Model HK-1
- Strap Model STR-1



Specifications

Item	CON-PT-M-ENG	CON-T-ENG	RCM-E-ENG
Data input	○	○	○
Actuator motion	○	○	○
Ambient operating temp/humidity	Temp: 0~40°C; Humidity: 85% RH or below		
Ambient operating atmosphere	No corrosive gases. Especially no dust.		
Protection class	IP40	IP54	-
Weight	Approx. 750g	Approx. 400g	Approx. 400g
Cable length	5m		
Display	3-color LED touch panel with backlight	20 char × 4 lines LCD .display	16 char. × 2 lines LCD display

PC Software (Windows Only)

Features A startup support software for inputting positions, performing test runs, and monitoring. With enhancements for adjustment functions, the startup time is shortened.

Model **RCM-101-MW** (External device communications cable + RS232 conversion unit)

Configuration

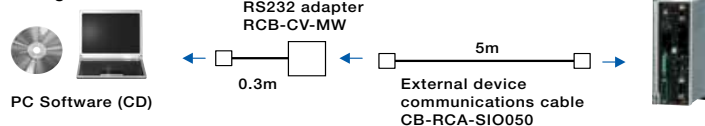

Model **RCM-101-USB** (External device communications cable + USB adapter + USB cable)

Configuration

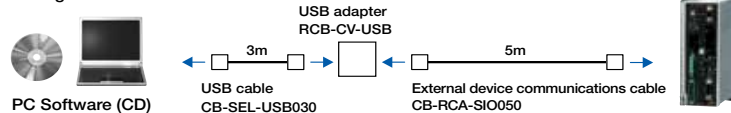

Regenerative Resistance Unit

Features A unit that returns the regenerative current, generated during the acceleration/deceleration of the motor, into heat. In the tables below, check the total power output of the actuator to see if a regenerative resistor is needed.

Model **REU-2** (for SCON/SSEL)

Specifications

Actuator weight	0.9kg
Internal regenerative resistance	220Ω 80W
Actuator-Controller Connection Cable (included)	CB-SC-REU010 (for SSEL)

Required Number of Units

	Horizontal	Vertical
0 units	~100W	~100W
1 unit	~400W	~400W
2 units	~750W	~750W

Required Number of Units (RCS2-RA13R only)

	2.5 lead	1.25 lead
Horizontal	1 unit	0 units
Vertical	1 unit	1 unit

* Depending on the operating conditions, more regenerative resistor may be needed.

* If two regenerative units are needed, acquire one REU-2 and one REU-1 (See P596).

Battery for retaining absolute data

Features Battery for saving absolute data, when operating an actuator with an absolute encoder.

Model **AB-5**

Exterior Dimensions

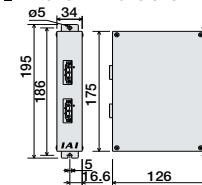

555

SCON

- Slider Type
- Mini
- Standard
- Controllers Integrated
- Rod Type
- Mini
- Standard
- Controllers Integrated
- Table/Arm /FlatType
- Mini
- Standard
- Gripper/ Rotary Type
- Linear Servo Type
- Cleanroom Type
- Splash-Proof
- Controllers
- PMEC /AMEC
- PSEP /ASEP
- ROBO NET
- ERC2
- PCON
- ACON
- SCON
- PSEL
- ASEL
- SSEL
- XSEL
- Pulse Motor
- Servo Motor (24V)
- Servo Motor (200V)
- Linear Servo Motor

Spare parts

When you need spare parts after purchasing the product, such as when replacing a cable, refer to the list of models below.

Motor cable/Motor robot cable

Model **CB-RCC-MA** / **CB-RCC-MA** -RB

* Enter the cable length (L) into . Compatible to a maximum of 30 meters.
Ex.: 080 = 8 m

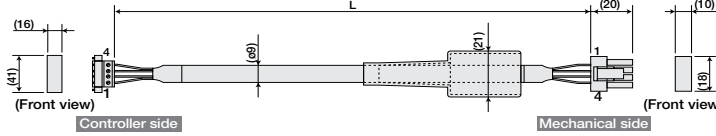

Min. bend radius $r = 50$ mm or larger
(when movable type is used)
* Only the robot cable is to be used in a cable track.

Wire	Color	Signal	Pin No.
0.75sq	Green	PE	1
	Red	U	2
	White	V	3
	Black	W	4

Pin No.	Signal	Color	Wire
1	U	Red	0.75sq (crimped)
2	V	White	
3	W	Black	
4	PE	Green	

Encoder cable/Encoder robot cable

Model **CB-RCS2-PA** / **CB-X3-PA**

* Enter the cable length (L) into . Compatible to a maximum of 30 meters.
Ex.: 080 = 8 m

Min. bend radius $r = 50$ mm or larger
(when movable type is used)
* Only robot cable is to be used in a cable track.

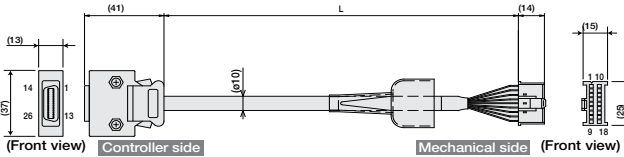

Wire	Color	Signal	Pin No.
---	---	---	10
---	---	---	11
---	---	---	12
---	---	---	13
---	---	---	14
---	---	---	15
---	---	---	16
---	---	---	17
---	---	---	18
---	---	---	19
---	---	---	20
---	---	---	21
---	---	---	22
---	---	---	23
---	---	---	24
---	---	---	25
---	---	---	26
---	---	---	27
---	---	---	28
---	---	---	29
---	---	---	30
---	---	---	31
---	---	---	32
---	---	---	33
---	---	---	34
---	---	---	35
---	---	---	36
---	---	---	37
---	---	---	38
---	---	---	39
---	---	---	40
---	---	---	41
---	---	---	42
---	---	---	43
---	---	---	44
---	---	---	45
---	---	---	46
---	---	---	47
---	---	---	48
---	---	---	49
---	---	---	50
---	---	---	51
---	---	---	52
---	---	---	53
---	---	---	54
---	---	---	55
---	---	---	56
---	---	---	57
---	---	---	58
---	---	---	59
---	---	---	60
---	---	---	61
---	---	---	62
---	---	---	63
---	---	---	64
---	---	---	65
---	---	---	66
---	---	---	67
---	---	---	68
---	---	---	69
---	---	---	70
---	---	---	71
---	---	---	72
---	---	---	73
---	---	---	74
---	---	---	75
---	---	---	76
---	---	---	77
---	---	---	78
---	---	---	79
---	---	---	80
---	---	---	81
---	---	---	82
---	---	---	83
---	---	---	84
---	---	---	85
---	---	---	86
---	---	---	87
---	---	---	88
---	---	---	89
---	---	---	90
---	---	---	91
---	---	---	92
---	---	---	93
---	---	---	94
---	---	---	95
---	---	---	96
---	---	---	97
---	---	---	98
---	---	---	99
---	---	---	100

Encoder cable/Encoder robot cable for RCS2-RT6/RT6R/RT7/RA13R

Model **CB-RCS2-PLA** / **CB-X2-PLA**

* Enter the cable length (L) into . Compatible to a maximum of 30 meters.
Ex.: 080 = 8 m

Min. bend radius $r = 50$ mm or larger
(when movable type is used)
* Only the robot cable is to be used in a cable track.

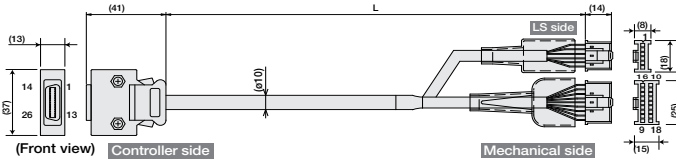

Wire	Color	Signal	Pin No.
---	---	---	10
---	---	---	11
---	---	---	12
---	---	---	13
---	---	---	14
---	---	---	15
---	---	---	16
---	---	---	17
---	---	---	18
---	---	---	19
---	---	---	20
---	---	---	21
---	---	---	22
---	---	---	23
---	---	---	24
---	---	---	25
---	---	---	26
---	---	---	27
---	---	---	28
---	---	---	29
---	---	---	30
---	---	---	31
---	---	---	32
---	---	---	33
---	---	---	34
---	---	---	35
---	---	---	36
---	---	---	37
---	---	---	38
---	---	---	39
---	---	---	40
---	---	---	41
---	---	---	42
---	---	---	43
---	---	---	44
---	---	---	45
---	---	---	46
---	---	---	47
---	---	---	48
---	---	---	49
---	---	---	50
---	---	---	51
---	---	---	52
---	---	---	53
---	---	---	54
---	---	---	55
---	---	---	56
---	---	---	57
---	---	---	58
---	---	---	59
---	---	---	60
---	---	---	61
---	---	---	62
---	---	---	63
---	---	---	64
---	---	---	65
---	---	---	66
---	---	---	67
---	---	---	68
---	---	---	69
---	---	---	70
---	---	---	71
---	---	---	72
---	---	---	73
---	---	---	74
---	---	---	75
---	---	---	76
---	---	---	77
---	---	---	78
---	---	---	79
---	---	---	80
---	---	---	81
---	---	---	82
---	---	---	83
---	---	---	84
---	---	---	85
---	---	---	86
---	---	---	87
---	---	---	88
---	---	---	89
---	---	---	90
---	---	---	91
---	---	---	92
---	---	---	93
---	---	---	94
---	---	---	95
---	---	---	96
---	---	---	97
---	---	---	98
---	---	---	99
---	---	---	100

I/O Flat Cable

Model **CB-PAC-PIO**

* Enter the cable length (L) into . Compatible to a maximum of 10 meters.
Ex.: 080 = 8 m

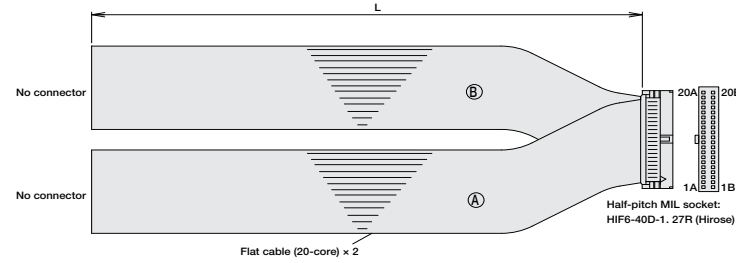

Pin No.	Signal	Color	Wire
1A	24V	Brown-1	
2A	24V	Red-1	
3A	---	Orange-1	
4A	---	Yellow-1	
5A	IN0	Green-1	
6A	IN1	Blue-1	
7A	IN2	Purple-1	
8A	IN3	Gray-1	
9A	IN4	White-1	
10A	IN5	Black-1	
11A	IN6	Brown-2	
12A	IN7	Red-2	
13A	IN8	Orange-2	
14A	IN9	Yellow-2	
15A	IN10	Green-2	
16A	IN11	Blue-2	
17A	IN12	Purple-2	
18A	IN13	Gray-2	
19A	IN14	White-2	
20A	IN15	Black-2	
1B	OUT0	Brown-3	
2B	OUT1	Red-3	
3B	OUT2	Orange-3	
4B	OUT3	Yellow-3	
5B	OUT4	Green-3	
6B	OUT5	Blue-3	
7B	OUT6	Purple-3	
8B	OUT7	Gray-3	
9B	OUT8	White-3	
10B	OUT9	Black-3	
11B	OUT10	Brown-4	
12B	OUT11	Red-4	
13B	OUT12	Orange-4	
14B	OUT13	Yellow-4	
15B	OUT14	Green-4	
16B	OUT15	Blue-4	
17B	---	Purple-4	
18B	---	Gray-4	
19B	OV	White-4	
20B	OV	Black-4	

SCON Pulse Train Control Cable

Model **CB-SC-PIOS**

* Enter the cable length (L) into . Compatible to a maximum of 10 meters.
Ex.: 080 = 8 m

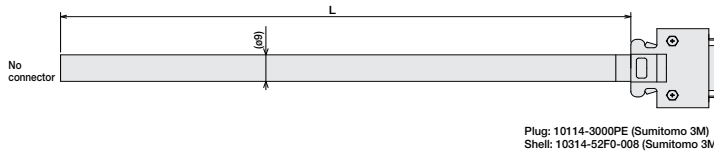

Wire	Color	Signal	Pin No.
Black	Black	Not used	1
White/Black	White/Black	Not used	2
Red	Red	PP	3
White/Red	White/Red	PP	4
Green	Green	NP	5
White/Green	White/Green	NP	6
Yellow	Yellow	AFB	7
White/Yellow	White/Yellow	AFB	8
Brown	Brown	BFB	9
White/Brown	White/Brown	BFB	10
Blue	Blue	ZFB	11
White/Blue	White/Blue	ZFB	12
Gray	Gray	GND	13
White/Gray	White/Gray	GND	14
Shield	Shield		

- Slider Type
- Mini
- Standard
- Controllers Integrated
- Fcd Type
- Mini
- Standard
- Controllers Integrated
- Table/Arm /FlatType
- Mini
- Standard
- Gripper/ Rotary Type
- Linear Servo Type
- Cleanroom Type
- Splash-Proof
- Controllers
- PMEC /AMEC
- PSEP /ASEP
- ROBO NET
- ERC2
- PCON
- ACON
- SCON
- PSEL
- ASEL
- SSEL
- XSEL
- Pulse Motor
- Servo Motor (24V)
- Servo Motor (200V)
- Linear Servo Motor

- Slider Type
- Mini
- Standard
- Controllers Integrated
- Rod Type
- Mini
- Standard
- Controllers Integrated
- Table/Arm /Flat Type
- Mini
- Standard



**Program controller
For RCP3/RCP2 Series**

List of models

Program controller for operating RCP3 / RCP2 Series actuators. Various control functions are combined into a single unit.

Type	C	
Name	Program mode	Positioner Mode
External View		
Description	Both the actuator operation and communication with external equipment can be handled by a single controller. When two axes are connected, arc interpolation, path operations, and synchronization can be performed.	Up to 1500 positioning points are supported. Push-motion operation and teaching operation are also possible.
Position points	1500 points	
Maximum number of control axes	2	

- Gripper/ Rotary Type
- Linear Servo Type
- Cleanroom Type
- Splash-Proof
- Controllers
- PMEC /AMEC
- PSEP /ASEP
- ROBO NET
- ERC2

Model

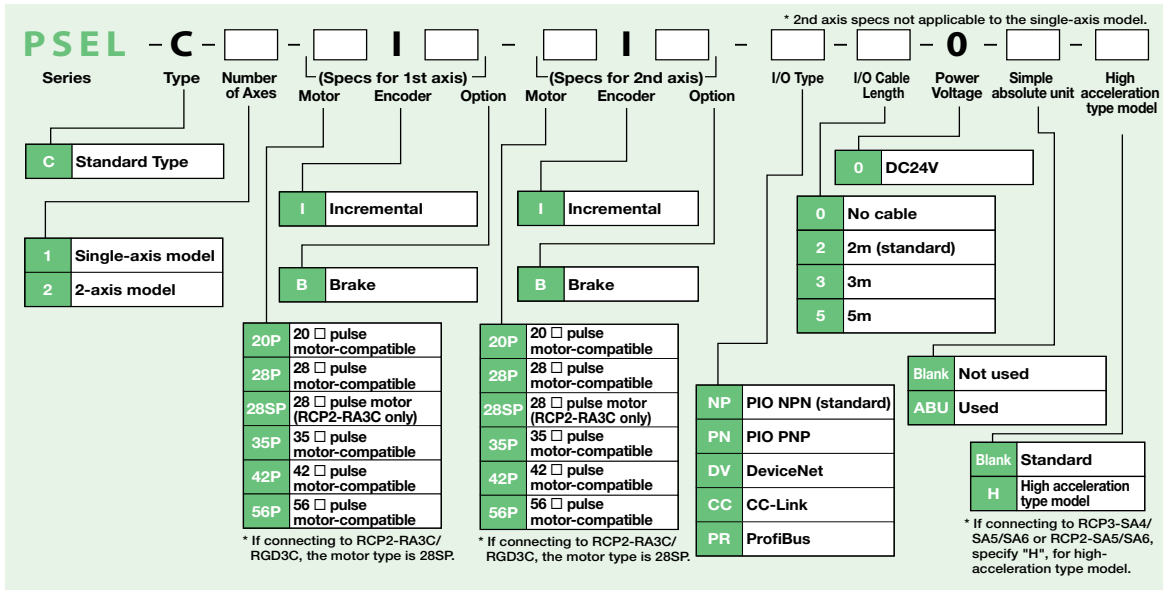

- Pulse Motor
- Servo Motor (24V)
- Servo Motor (200V)
- Linear Servo Motor

557 PSEL

System configuration

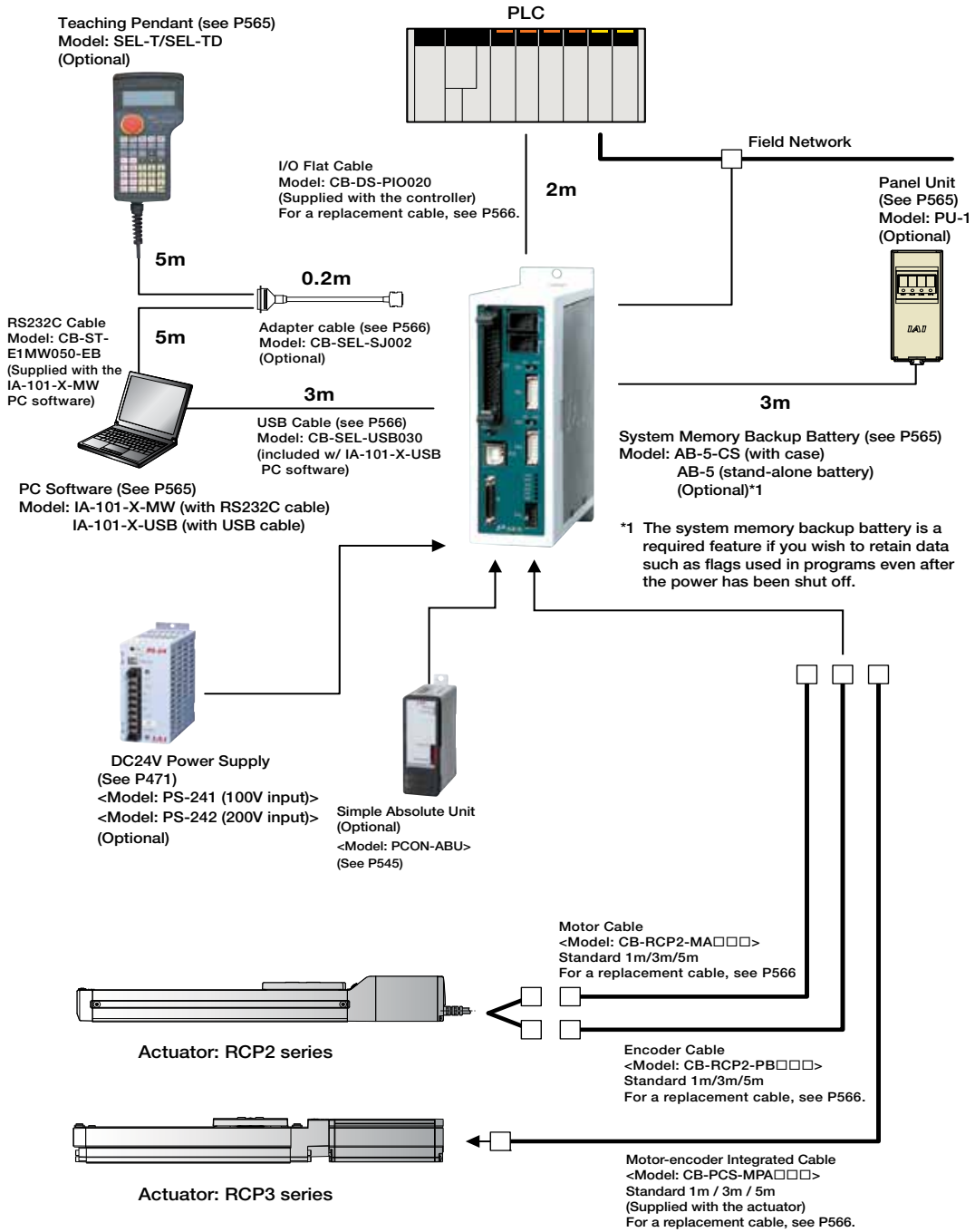

- Slider Type
- Mini
- Standard
- Controllers Integrated
- Rod Type
- Mini
- Standard
- Controllers Integrated
- Table/Arm /Flat Type
- Mini
- Standard
- Gripper/ Rotary Type
- Linear Servo Type
- Cleanroom Type
- Splash-Proof
- Controllers**
- PMEC /AMEC
- PSEP /ASEP
- ROBO NET
- ERC2
- PCON
- ACON
- SCON
- PSEL**
- ASEL
- SSEL
- XSEL
- Pulse Motor**
- Servo Motor (24V)
- Servo Motor (200V)
- Linear Servo Motor

I/O Specifications

Input section External input specifications

Item	Specifications
Input voltage	DC24V ±10%
Input current	7mA / circuit
ON/OFF voltage	ON voltage (min.) NPN : DC16V / PNP : DC8V OFF voltage (max.) NPN : DC5V / PNP : DC19V
Isolation method	Photocoupler

NPN Specifications

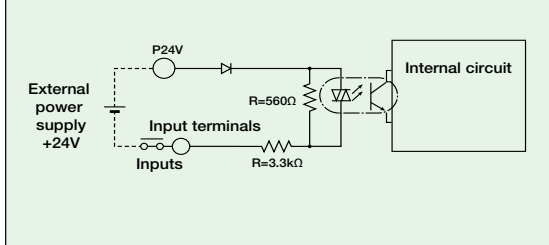

PNP Specifications

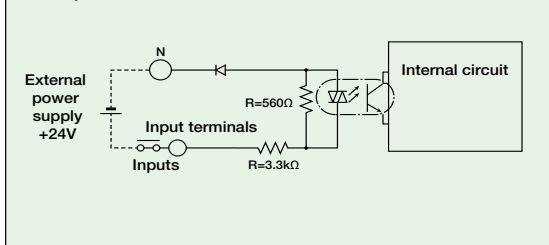

Output section External output specifications

Item	Specifications
Load Voltage	DC24V
Max. load current	100mA / 1 point 400mA / 8 points in total
Residual voltage (Max.)	Max 0.1mA / 1 point
Isolation method	Photocoupler

NPN Specifications

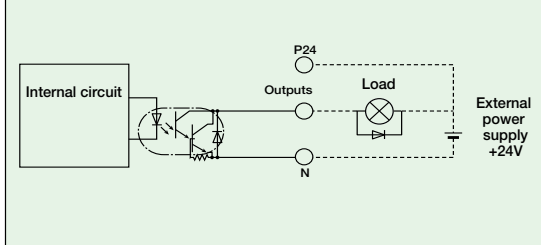

PNP Specifications

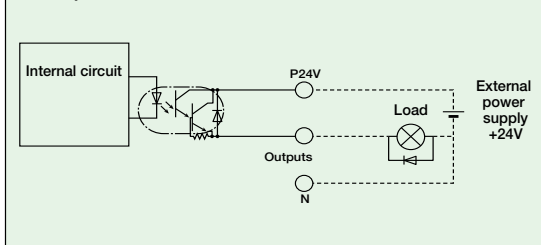

Explanation of I/O Signal Functions

Two modes can be selected for the SSEL controller: "Program Mode," in which the actuator is operated by entering a program, and "Positioner Mode," in which PLC signals are received and the actuator is moved to designated positions. The Positioner Mode has the five input patterns listed below to enable various applications.

Control Function by Type

Operation mode	Features
Program mode	Various operations including linear/arc interpolation operation, path operation ideal for coating processes, etc., arch-motion operation and palletizing operation can be performed using the Super SEL language that lets you program complex control actions using simple commands.
Positioner mode	Standard mode This is the basic mode from which operations can be conducted by designating position numbers and inputting the start signal. Push-motion operation and teaching operation are also possible.
	Product Change mode Multiple work parts of the same shape with slightly different hole positions can be handled using movement commands to the same position numbers by simply changing the product type number.
	2-axis independent mode With a 2-axis controller, each axis can be commanded and operated separately.
	Teaching mode In this mode, the slider (rod) moves based on an external signal, when the actuator is stopped, the current location can be registered as position data.
	DS-S-C1 Compatible mode If you were using a DS-S-C1 controller, you can replace it with a PSEL controller without having to change the host programs. *This mode does not ensure actuator compatibility.

- Slider Type
- Mini
- Standard
- Controllers Integrated
- Rod Type
- Mini
- Standard
- Controllers Integrated
- Table/Arm /Flat Type
- Mini
- Standard
- Gripper/ Rotary Type
- Linear Servo Type
- Cleanroom Type
- Splash-Proof
- Controllers
- PMEC /AMEC
- PSEP /ASEP
- ROBO NET
- ERC2
- PCON
- ACON
- SCON
- PSEL
- ASEL
- SSEL
- XSEL
- Pulse Motor
- Servo Motor (24V)
- Servo Motor (200V)
- Linear Servo Motor

Explanation of I/O Signal Functions

Program mode

Pin Number	Classification	Port No.	Program Mode	Functions	Wiring Diagram	
1A	P24	016	24V input	Connect 24V.		
1B			Select Program No. 1	Selects the program number to start. (Input as BCD values to ports 016 to 022)		
2A			Select Program No. 2			
2B			Select Program No. 4			
3A			Select Program No. 8			
3B			Select Program No. 10			
4A			Select Program No. 20			
4B			Select Program No. 40			
5A			CPU reset			Resets the system to the same state as when the power is turned on.
5B			Start			Starts the program selected by ports 016 to 022.
6A			General-purpose input			Waits for external input via program instructions.
6B			General-purpose input			
7A			General-purpose input			
7B	General-purpose input					
8A	General-purpose input					
8B	General-purpose input					
9A	General-purpose input					
9B	General-purpose input					
10A	General-purpose input					
10B	General-purpose input					
11A	General-purpose input	Turns off when an alarm occurs. (Contact B)				
11B	General-purpose input					
12A	General-purpose input					
12B	General-purpose input					
13A	General-purpose input					
13B	Alarm					
14A	Ready		Turns on when the controller starts up normally and is in an operable state.			
14B	General-purpose output	These outputs can be turned ON/OFF as desired via program instructions.				
15A	General-purpose output					
15B	General-purpose output					
16A	General-purpose output					
16B	General-purpose output					
17A	General-purpose output					
17B	N	0V input	Connect 0V.			

Note: This is for NPN. PNP will be different.

Positioner mode

Pin Number	Classification	Port No.	Positioner Standard Mode	Functions	Wiring Diagram	
1A	P24	016	24V input	Connect 24V.		
1B			Position input 10	Specifies the position numbers to move to, using port number 007 to 019. The number can be specified either as BCD or binary.		
2A			Position input 11			
2B			Position input 12			
3A			Position input 13			
3B			-			
4A			-			
4B			-			
5A			Error reset			Resets minor errors. (Severe errors require a restart.)
5B			Start			Starts moving to selected position.
6A			Home return			Performs home return.
6B			Servo ON			Switches between Servo ON and OFF.
7A			Push			Performs a push motion.
7B	Pause	Pauses the motion when turned OFF, and resumes when turned ON.				
8A	Cancel	Stops the motion when turned OFF. The remaining motion is canceled.				
8B	Interpolation settings	When this signal is turned ON for a 2-axis model, the actuator moves by linear interpolation.				
9A	Position input 1	Specifies the position numbers to move to, using ports 007 to 019. The number can be specified either as BCD or binary.				
9B	Position input 2					
10A	Position input 3					
10B	Position input 4					
11A	Position input 5					
11B	Position input 6					
12A	Position input 7					
12B	Position input 8					
13A	Position input 9	Turns off when an alarm occurs. (Contact B)				
13B	Alarm					
14A	Ready		Turns on when the controller starts up normally and is in an operable state.			
14B	Positioning complete		Turns on when the movement to the destination is complete.			
15A	Home return complete		Turns on when the home return operation is complete.			
15B	Servo ON output		Turns on when servo is ON.			
16A	Pushing complete		Turns on when a push motion is complete.			
16B	System battery error	Turns on when the system battery runs low (warning level).				
17A	-	-				
17B	N	0V input	Connect 0V.			

Note: This is for NPN. PNP will be different.

- Slider Type
- Mini
- Standard
- Controllers Integrated
- Rod Type
- Mini
- Standard
- Controllers Integrated
- Table/Arm /Flat Type
- Mini
- Standard
- Cripper/ Rotary Type
- Linear Servo Type
- Cleanroom Type
- Splash-Proof
- Controllers
- PMEC /AMEC
- PSEP /ASEP
- ROBO NET
- ERC2
- PCON
- ACON
- SCON
- PSEL
- ASEL
- SSEL
- XSEL
- Pulse Motor
- Servo Motor (24V)
- Servo Motor (200V)
- Linear Servo Motor

PSEL 560

Explanation of I/O Signal Functions

Positioner, Product-Type Change Mode

Pin Number	Classification	Port No.	Positioner Product Type Change Mode	Functions		
1A	P24	/	24V input	Connect 24V.		
1B			016	Position/Product Type Input 10	Specifies the position numbers to move to, and the product type numbers, using ports 007 to 022. The position and product type numbers are assigned by parameter settings. The number can be specified either as BCD or binary.	
2A			017	Position/Product Type Input 11		
2B			018	Position/Product Type Input 12		
3A			019	Position/Product Type Input 13		
3B			020	Position/Product Type Input 14		
4A			021	Position/Product Type Input 15		
4B			022	Position/Product Type Input 16		
5A			023	Error reset		Resets minor errors. (Severe errors require a restart.)
5B			000	Start		Starts moving to selected position.
6A			001	Home return		Performs home return.
6B			002	Servo ON		Switches between Servo ON and OFF.
7A			003	Push		Performs a push motion.
7B			004	Pause		Pauses the motion when turned OFF, and resumes when turned ON.
8A			005	Cancel		Stops the motion when turned OFF. The remaining motion is canceled.
8B			006	Interpolation settings		When this signal is turned ON for a 2-axis model, the actuator moves by linear interpolation.
9A	007	Position/Product Type Input 1	Specifies the position numbers to move to, and the product type numbers, using ports 007 to 022. The position and product type numbers are assigned by parameter settings. The number can be specified either as BCD or binary.			
9B	008	Position/Product Type Input 2				
10A	009	Position/Product Type Input 3				
10B	010	Position/Product Type Input 4				
11A	011	Position/Product Type Input 5				
11B	012	Position/Product Type Input 6				
12A	013	Position/Product Type Input 7				
12B	014	Position/Product Type Input 8				
13A	015	Position/Product Type Input 9				
13B	300	Alarm		Turns off when an alarm occurs. (Contact B)		
14A	301	Ready		Turns on when the controller starts up normally and is in an operable state.		
14B	302	Positioning complete		Turns on when the movement to the destination is complete.		
15A	303	Home return complete		Turns on when the home return operation is complete.		
15B	304	Servo ON output		Turns on when servo is ON.		
16A	305	Pushing complete		Turns on when a push motion is complete.		
16B	306	System battery error		Turns on when the system battery runs low (warning level).		
17A	307	-	-			
17B	N	/	0V input	Connect 0V.		

Wiring Diagram

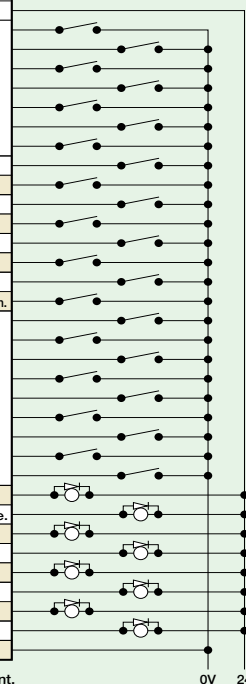

Note: This is for NPN. PNP will be different.

Positioner, 2-axis Independent Mode

Pin Number	Classification	Port No.	Positioner 2-axis Independent Mode	Functions		
1A	P24	/	24V input	Connect 24V.		
1B			016	Position input 7	Specifies the position numbers to move to, using ports 010 to 022. The position numbers on the 1st and 2nd axes are assigned by parameter settings. The number can be specified either as BCD or binary.	
2A			017	Position input 8		
2B			018	Position input 9		
3A			019	Position input 10		
3B			020	Position input 11		
4A			021	Position input 12		
4B			022	Position input 13		
5A			023	Error reset		Resets minor errors. (Severe errors require a restart.)
5B			000	Start 1		Starts the movement to the selected position number on the 1st axis.
6A			001	Home return 1		Performs home return on the 1st axis.
6B			002	Servo ON 1		Switches between servo ON and OFF for the 1st axis.
7A			003	Pause 1		Pauses the motion on 1st axis when turned OFF, and resumes when turned ON.
7B			004	Cancel 1		Cancels the movement on the 1st axis.
8A			005	Start 2		Starts the movement to the selected position number on the 2nd axis.
8B			006	Home return 2		Performs home return on the 2nd axis.
9A	007	Servo ON 2	Switches between servo ON and OFF for the 2nd axis.			
9B	008	Pause 2	Pauses the motion on 2nd axis when turned OFF, and resumes when turned ON.			
10A	009	Cancel 2	Cancels the movement on the 2nd axis.			
10B	010	Position input 1	Specifies the position numbers to move to, using ports 010 to 022. The position numbers on the 1st and 2nd axes are assigned by parameter settings. The number can be specified either as BCD or binary.			
11A	011	Position input 2				
11B	012	Position input 3				
12A	013	Position input 4				
12B	014	Position input 5				
13A	015	Position input 6				
13B	300	Alarm		Turns off when an alarm occurs. (Contact B)		
14A	301	Ready		Turns on when the controller starts up normally and is in an operable state.		
14B	302	Positioning complete 1		Turns on when the movement to the specified position on the 1st axis is complete.		
15A	303	Home return complete 1		Turns on when home return on the 1st axis is complete.		
15B	304	Servo ON output 1		Turns on when the 1st axis is in a servo ON state.		
16A	305	Positioning complete 2		Turns on when the movement to the specified position on the 2nd axis is complete.		
16B	306	Home return complete 2		Turns on when home return on the 2nd axis is complete.		
17A	307	Servo ON output 2		Turns on when the 2nd axis is in a servo ON state.		
17B	N	/		0V input	Connect 0V.	

Wiring Diagram

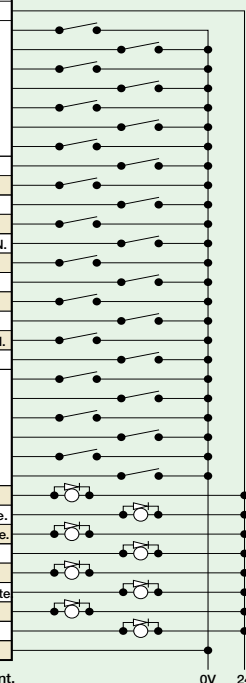

Note: This is for NPN. PNP will be different.

561 PSEL

- Slider Type
- Mini
- Standard
- Controllers Integrated
- Rod Type
- Mini
- Standard
- Controllers Integrated
- Table/Arm /Flat Type
- Mini
- Standard
- Gripper/ Rotary Type
- Linear Servo Type
- Cleanroom Type
- Splash-Proof
- Controllers
- PMEC /AMEC
- PSEP /ASEP
- ROBO NET
- ERC2
- PCON
- ACON
- SDON
- PSEL
- ASEL
- SSEL
- XSEL
- Pulse Motor
- Servo Motor (24V)
- Servo Motor (200V)
- Linear Servo Motor

Explanation of I/O Signal Functions

Positioner, Teaching Mode

Pin Number	Classification	Port No.	Positioner Teaching Mode	Functions	Wiring Diagram	
1A	P24		24V input	Connect 24V.		
1B		016	JOG- on 1st axis	While the signal is on, the 1st axis is moved in the - (negative) direction.		
2A		017	JOG+ on 2nd axis	While the signal is on, the 2nd axis is moved in the + (positive) direction.		
2B		018	JOG- on 2nd axis	While the signal is on, the 2nd axis is moved in the - (negative) direction.		
3A		019	Specify inching (0.01mm)	Specifies how much to move during inching. (Total of the values specified for ports 019 to 022)		
3B		020	Specify inching (0.1mm)			
4A		021	Specify inching (0.5mm)			
4B		022	Specify inching (1mm)			
5A		023	Error reset	Resets minor errors. (Severe errors require a restart.)		
5B		000	Start	Starts moving to selected position.		
6A		001	Servo ON	Switches between Servo ON and OFF.		
6B		002	Pause	Pauses the motion when turned OFF, and resumes when turned ON.		
7A		Input	003	Position input 1		Ports 003 to 013 are used to specify the position number to move, and the position number for inputting the current position. - When the teaching mode setting on port 014 is in the ON state, the current value is written to the specified position number.
7B			004	Position input 2		
8A			005	Position input 3		
8B			006	Position input 4		
9A			007	Position input 5		
9B	008		Position input 6			
10A	009		Position input 7			
10B	010		Position input 8			
11A	011		Position input 9			
11B	012		Position input 10			
12A	013		Position input 11			
12B	014	Teaching mode setting				
13A	015	JOG+ on 1st axis	While the signal is on, the 1st axis is moved in the + (positive) direction.			
13B	300	Alarm	Turns off when an alarm occurs. (Contact B)			
14A	301	Ready	Turns on when the controller starts up normally and is in an operable state.			
14B	302	Positioning complete	Turns on when the movement to the destination is complete.			
15A	303	Home return complete	Turns on when the home return operation is complete.			
15B	304	Servo ON output	Turns on when servo is ON.			
16A	305	-	-			
16B	306	System battery error	Turns on when the system battery runs low (warning level).			
17A	307	-	-			
17B	N		0V input	Connect 0V.		

Note: This is for NPN. PNP will be different.

Positioner, DS-S-C1 Compatible Mode

Pin Number	Classification	Port No.	Positioner DS-S-C1 Compatible Mode	Functions	Wiring Diagram
1A	P24		24V input	Connect 24V.	
1B		016	Position No. 1000	(Same as ports 004 through 015)	
2A		017	-	-	
2B		018	-	-	
3A		019	-	-	
3B		020	-	-	
4A		021	-	-	
4B		022	-	-	
5A		023	CPU reset	Resets the system to the same state as when the power is turned on.	
5B		000	Start	Starts moving to selected position.	
6A		001	Hold (Pause)	Pauses the motion when turned ON, and resumes when turned OFF.	
6B		002	Cancel	Stops the motion when turned ON. The remaining motion is canceled.	
7A		003	Interpolation settings	When this signal is turned ON for a 2-axis model, the actuator moves by linear interpolation.	
7B		004	Position No. 1	Ports 004 through 016 are used to specify the position number to move. The numbers are specified as BCD.	
8A		005	Position No. 2		
8B		006	Position No. 4		
9A		007	Position No. 8		
9B	008	Position No. 10			
10A	009	Position No. 20			
10B	010	Position No. 40			
11A	011	Position No. 80			
11B	012	Position No. 100			
12A	013	Position No. 200			
12B	014	Position No. 400			
13A	015	Position No. 800			
13B	300	Alarm	Turns off when an alarm occurs. (Contact A)		
14A	301	Ready	Turns on when the controller starts up normally and is in an operable state.		
14B	302	Positioning complete	Turns on when the movement to the destination is complete.		
15A	303	-	-		
15B	304	-	-		
16A	305	-	-		
16B	306	System battery error	Turns on when the system battery runs low (warning level).		
17A	307	-	-		
17B	N		0V input	Connect 0V.	

Note: This is for NPN. PNP will be different.

- Slider Type
- Mini
- Standard
- Controllers Integrated
- Rod Type
- Mini
- Standard
- Controllers Integrated
- Table/Arm /Flat Type
- Mini
- Standard
- Gripper/ Rotary Type
- Linear Servo Type
- Cleanroom Type
- Splash-Proof
- Controllers
- PMEC /AMEC
- PSEP /ASEP
- ROBO NET
- ERC2
- PCON
- ACON
- SCON
- PSEL
- ASEL
- SSEL
- XSEL
- Pulse Motor
- Servo Motor (24V)
- Servo Motor (200V)
- Linear Servo Motor

Table of specifications

	Item	Specifications
Basic Specifications	Connected actuator	RCP2 series actuator (Note 1)
	Input voltage	DC24V ±10%
	Power Supply Capacity	Control power (Max. 1.2A) + Motor power (See the table below)
	Dielectric strength voltage	DC500V 10MΩ or higher
	Withstand voltage	AC500V 1 min.
	Rush current	Max. 30A
	Vibration resistance	XYZ directions 10 to 57Hz, One side amplitude: 0.035mm (continuous), 0.075mm (intermittent) 58 to 150 Hz 4.9 m/s ² (continuous), 9.8 m/s ² (intermittent)
Control specification	Maximum total output of connected axis	-
	Position detection method	Incremental encoder
	Speed setting	From 1mm/s. The maximum limit varies depending on the actuator.
	Acceleration setting	From 0.01G. The maximum limit varies depending on the actuator.
	Operating method	Program operation / Positioner operation (switchable)
Program	Programming language	Super SEL language
	Number of programs	64 programs
	Number of program steps	2000 steps
	Number of multi-tasking programs	8 programs
	Positioning Points	1500 points
	Data memory device	FLASHROM (A system-memory backup battery can be added as an option)
	Data input method	Teaching pendant or PC software
Communication	Number of I/O	24 input points / 8 output points (NPN or PNP selectable)
	I/O power	Externally supplied 24VDC ± 10%
	PIO cable	CB-DS-PIO □□□ (supplied with the controller)
	Serial communications function	RS232C (Half-pitch connector) / USB connector
	Field Network	DeviceNet, CC-Link, ProfiBus
	Motor Cable	CB-RCP2-MA □□□ (Max. 20m)
	Encoder cable	CB-RCP2-PA □□□ (Max. 20m)
General specifications	Protection function	Motor driver temperature check, Encoder open-circuit check Soft limit over, system error, battery error, etc.
	Ambient operating humidity and temperature	0 to 40°C 10 to 95% (non-condensing)
	Ambient atmosphere	Free from corrosive gases. In particular, there shall be no significant powder dust.
	Protection class	IP20
	Weight	Approx. 450g
	External dimension	43 mm (W) x 159 mm (H) x 110 mm (D)

(Note 1) Cannot operate High-Thrust type (RA10C), High-Speed type (HS8C/HS8R), or Waterproof type (RCP2W-SA16).

Motorpower supply Capacity (Note2)	Motor type	1-Axis specifications		2-Axis specifications	
		Rated	Max.(Note 3)	Rated	Max.(Note 3)
	20P, 28P, 28SP motor	0.4A	2.0A	0.8A	4.0A
	35P, 42P, 56SP motor	1.2A		2.4A	

(Note 2) For both 1-axis and 2-axis specifications, approx. 30A inrush current flows for 5 ms when the control power supply is turned on.

(Note 3) After Servo ON, excitation detection is performed. In that case, the current is maximized. (Approx. 100 msec)

However, if motor drive power supply is turned on after a shut-down, approx. 6.0A and approx. 12.0A current flows to axis-1 and axis-2 respectively. (Approx. 1 to 2 msec)

Exterior dimensions

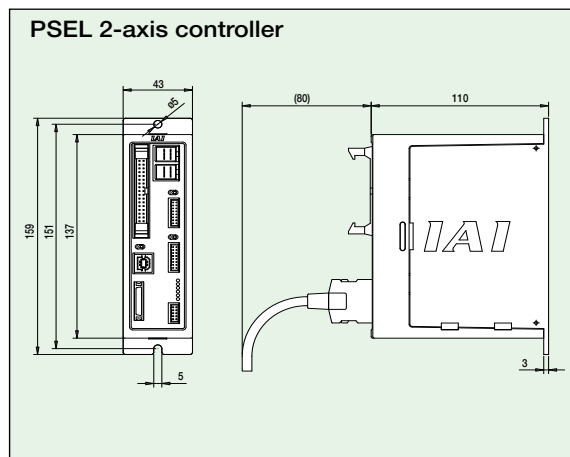
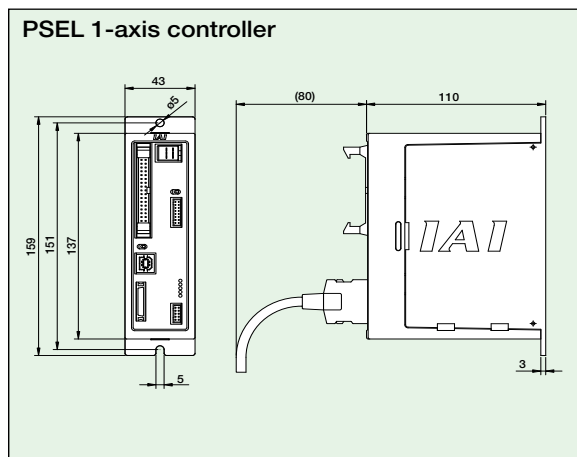

563

PSEL

- Slider Type
- Mini
- Standard
- Controllers Integrated
- Rod Type
- Mini
- Standard
- Controllers Integrated
- Table/Arm /Flat Type
- Mini
- Standard
- Gripper/ Rotary Type
- Linear Servo Type
- Cleanroom Type
- Splash-Proof
- Controllers
- PMEC /AMEC
- PSEP /ASEP
- ROBO NET
- ERC2
- PCON
- ACON
- SCON
- PSEL
- ASEL
- SSEL
- XSEL
- Pulse Motor
- Servo Motor (24V)
- Servo Motor (200V)
- Linear Servo Motor

Name of Each Part

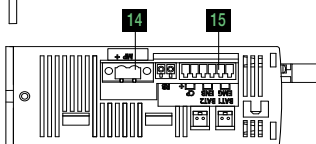
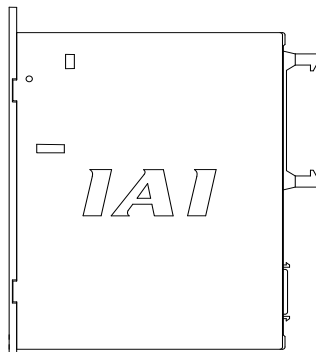
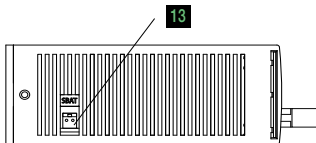
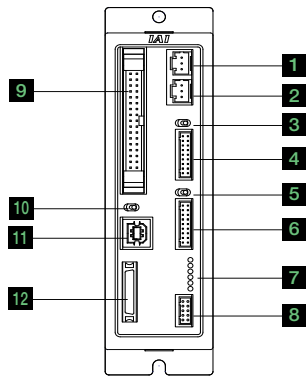

1 Motor connector for axis 1

Connects the motor cable of the axis 1 actuator.

2 Motor connector for axis 2

Connects the motor cable of the axis 2 actuator.

3 Brake switch for axis 1

This switch is used to release the axis brake. Setting it to the left position (RLS side) forcibly releases the brake, while setting it to the right position (NOM side) causes the controller to automatically control the brake.

4 Encoder connector for axis 1

Connect the encoder cable of the axis 1 actuator.

5 Brake switch for axis 2

This switch is used to release the axis brake. Setting it to the left position (RLS side) forcibly releases the brake, while setting it to the right position (NOM side) causes the controller to automatically control the brake.

6 Encoder connector for axis 2

Connect the encoder cable of the axis 2 actuator.

7 Status indicator LEDs

These LEDs are used to indicate the operating condition of the controller.

The LED status indicators are as follows:

- PWR : Power is input to controller.
- RDY : The controller is ready to perform program operation.
- ALM : The controller is abnormal.
- EMG : An emergency stop is actuated and the drive source is cut off.
- SV1 : The axis 1 actuator servo is on.
- SV2 : The axis 2 actuator servo is on.

8 Panel unit connector

A connector for the panel unit (optional) that displays the controller status and error codes.

9 I/O Connector

A connector for interface I/Os.

34-pin flat cable connector for DIO (24IN/8OUT) interface.

I/O power is also supplied to the controller via this connector (Pin No. 1 and No. 34).

10 Mode switch

This switch is used to specify the running mode of the controller. The left position indicates the MANU (manual operation) mode, while the right position indicates the AUTO (automatic operation) mode. Teaching can only be performed in manual operation, and automatic operation using external I/Os is not possible in the MANU mode.

11 USB connector

A connector for PC connection via USB. If the USB connector is connected, the TP connector is disabled and all communication inputs to the TP connector are cut off.

12 Teaching pendant connector

A half-pitch I/O 26-pin connector that connects a teaching pendant when the running mode is MANU. A special conversion cable is needed to connect a conventional D-sub, 25-pin connector.

13 System-memory backup battery connector

If you wish to retain the various data recorded in the SRAM of the controller even after the power is cut off, connect the necessary battery to this connector. This battery is installed externally to the unit. The controller does not come standard with the battery (Option).

14 Motor power input connector

This connector is used to input the motor power. It consists of a 2-pin, 2-piece connector by Phoenix Contact.

15 Control power/System input connector

This connector is used to connect the control power input, emergency stop switch, and enable switch. It consists of a Phoenix Contact 6-pin 2-piece connector.

- Slider Type
- Mini
- Standard
- Controllers Integrated
- Rod Type
- Mini
- Standard
- Controllers Integrated
- Table/Arm /Flat Type
- Mini
- Standard
- Cripper/ Rotary Type
- Linear Servo Type
- Cleanroom Type
- Splash-Proof
- Controllers
- PMEC /AMEC
- PSEP /ASEP
- ROBO NET
- ERC2
- PCON
- ACON
- SCON
- PSEL
- ASEL
- SSEL
- XSEL

- Pulse Motor
- Servo Motor (24V)
- Servo Motor (200V)
- Linear Servo Motor

Option

Teaching Pendant

Features This is a teaching device that provides information on functions such as position input, test runs, and monitoring.

Model

Model	Description
SEL-T-J	Standard type with adapter cable
SEL-TD-J	Equipped with a deadman switch and adapter cable

Configuration

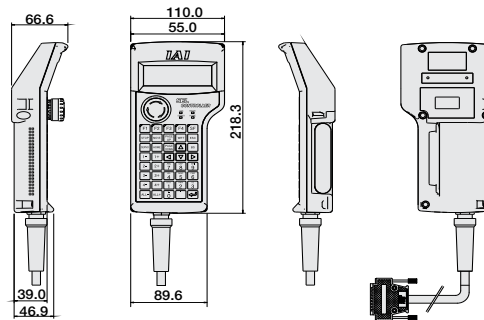
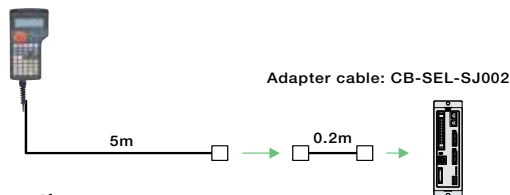

Specifications

Item	SEL-T-J	SEL-TD-J
3-position Enable Switch	No	Yes
ANSI/UL standards	Non-compliant	Compliant
CE mark	Compliant	
Display	20 char. x 4 lines	
Ambient Operating Temp./Humidity	0~40°C 10~90% RH (non-condensing)	
Protective structure	IP54	
Weight	Approx. 0.4kg (not incl. cable)	

SEL-T option

- Wall-mounting hook Model HK-1
- Strap Model STR-1

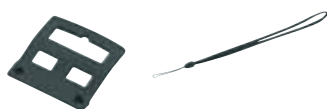

PC Software (Windows Only)

Features A startup support software for inputting programs/positions, performing test runs, and monitoring. More functions have been added for debugging, and improvements have been made to shorten the start-up time.

Model IA-101-X-MW-J (with RS232C cable + adapter cable)

Configuration

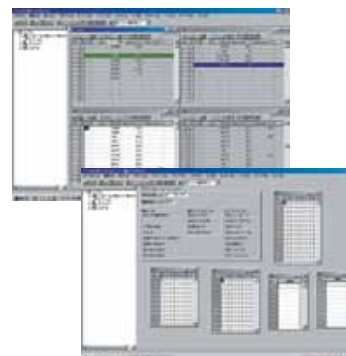
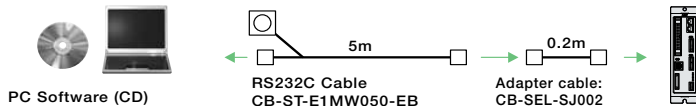

Note:
Only versions 7.0.0.0 and later can be used with the PSEL controller.

Model IA-101-X-USB (with USB cable)

Configuration

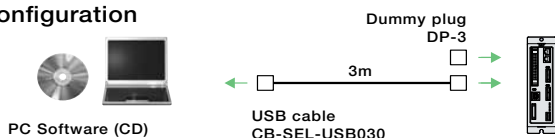

Panel Unit

Features Display device that shows the error code from the controller or the currently running program number.

Model PU-1 (Cable length: 3m)

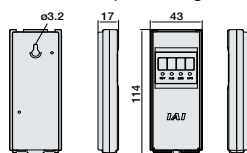

System Memory Backup Battery

Features This battery is required when you are using global flags in the program and you want to retain your data even after the power has been turned OFF.

Model AB-5-CS (with case)
AB-5 (stand-alone battery)



Dummy Plug

Features When connecting the PSEL controller to a computer with a USB cable, this plug is inserted in the teaching port to shut off the enable circuit. (Supplied with the PC software IA-101-X-USB)

Model DP-3



565 PSEL

Option

USB Cable

- Features** A cable for connecting the controller to the USB port to a computer. A controller with no USB port (e.g. XSEL) can be connected to the USB port of a computer by connecting an RS232C cable to the USB cable via a USB adapter. (See PC software IA-101-X-USBMW)
- Model** **CB-SEL-USB030** (Cable length: 3m)



Adapter Cable

- Features** An adapter cable to connect the D-sub 25-pin connector from the teaching pendant or a PC to the teaching connector (half-pitch) of the PSEL controller.
- Model** **CB-SEL-SJ002** (Cable length: 0.2m)



Spare Parts

When you need spare parts after purchasing the product, such as when replacing a cable, refer to the list of models below.

Motor cable

Model **CB-RCP2-MA** ** The standard cable for the motor cable is the robot cable. * Enter the cable length (L) into . Compatible to a maximum of 20 meters. Ex.: 080 = 8 m

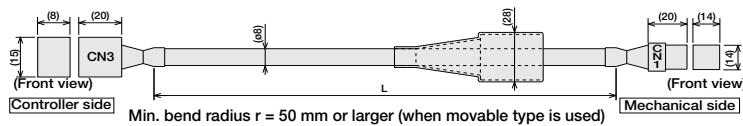

Wire	Color	Signal	Pin No.	Pin No.	Signal	Color	Wire
Orange	A	A1	1	1	A	Yellow	SLP-06V (JST)
Gray	VMM	A2	2	2	VMM	Gray	
White	B	A3	3	3	A	Orange	
Yellow	A	B1	4	4	B	Orange (Black 3)	
Pink	VMM	B2	5	5	VMM	Pink	
Orange (Black 1)	B	B3	6	6	B	White	

Encoder cable/Encoder robot cable

Model **CB-RCP2-PB** / **CB-RCP2-PB** -**RB** * The standard cable for the encoder cable is a normal cable. * Enter the cable length (L) into . Compatible to a maximum of 20 meters. A robot cable can be specified as an option. Ex.: 080 = 8 m

Min. bend radius $r = 50$ mm or larger (when movable type is used)
* Only robot cable is to be used in a cable track.

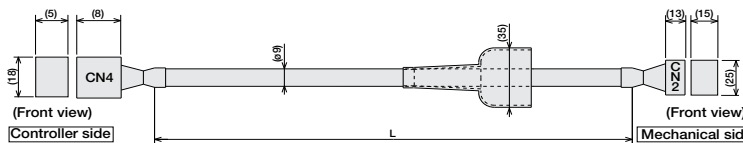

Cable color	Signal	Pin No.	Pin No.	Signal	Cable color	C N 2
Blue (Red 1)	Orange (Black 2), S +	16	1	E N A	Brown	Light Gray (Red 1)
White	Orange (Red 2), S -	15	2	E N A	Green	Light Gray (Red 1)
Red	Orange (Red 1), K +	14	3	E N B	Purple	White (Red 1)
Gray	Orange (Red 1), E N A	12	4	E N B	Pink	White (Red 1)
Green	Light Gray (Red 1), E N A	11	5	---	---	---
Purple	White (Black 1), E N B	10	6	---	---	---
Pink	White (Red 1), E N B	9	7	---	---	---
Yellow	Yellow (Black 1), V F S	7	8	---	---	---
Orange	Pink (Red 1), V B R	6	9	---	---	---
Blue	Pink (Black 1), GND	5	10	---	---	---
---	---	4	11	---	---	---
---	---	3	12	---	---	---
---	---	2	13	---	---	---
---	---	1	14	---	---	---
Ground	Ground	F.G.	15	---	---	---

Motor-Encoder Integrated Cable for RCP3

Model **CB-PCS-MPA** * Enter the cable length (L) into . Compatible to a maximum of 20 meters. Ex.: 080 = 8 m

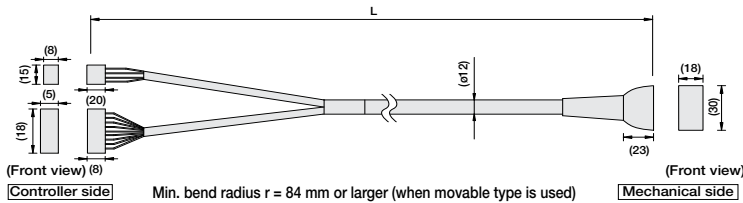

Signal	Pin Number	Wire color	Pin Number	Signal
A	B1	Black	A1	A
VMM	A2	White	B1	VMM
/A	A1	Red	A2	/A
B	B3	Green	B2	B
VMM	B2	Yellow	A3	VMM
/B	A3	Brown	B3	/B
---	---	---	B4	---
---	---	---	A4	---
BK+	14	Pink (Red +)	A5	BK+
BK-	15	Pink (Blue +)	B5	BK-
LS+	16	White (Red +)	A6	LS+
LS-	15	White (Blue +)	B6	LS-
A+	12	Orange (Red +)	A7	A+
A-	11	Orange (Blue +)	B7	A-
B+	10	Gray (Red +)	A8	B+
B-	9	Gray (Blue +)	B8	B-
NC	8	---	A9	NC
VCC	7	---	B9	VPS
GND	6	Orange (Blue + Contiguous)	A10	VCC
NC	5	Gray (Red + Contiguous)	B10	GND
NC	4	---	A11	NC
FG	1	---	B11	FG

I/O Flat Cable

Model **CB-DS-PIO** * Enter the cable length (L) into . Compatible to a maximum of 10 meters. Ex.: 080 = 8 m

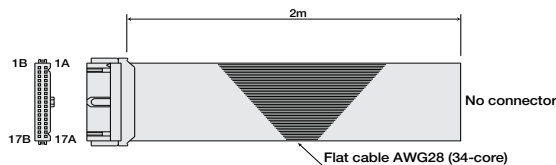

Pin No.	Color	Wire	Pin No.	Color	Wire
1A	Brown 1	---	9B	Gray 2	---
1B	Red 1	---	10A	White 2	---
2A	Orange 1	---	10B	Black 2	---
2B	Yellow 1	---	11A	Brown-3	---
3A	Green 1	---	11B	Red 3	---
3B	Blue 1	---	12A	Orange 3	---
4A	Purple 1	---	12B	Yellow 3	---
4B	Gray 1	---	13A	Green 3	---
5A	White 1	---	13B	Blue 3	---
5B	Black 1	---	14A	Purple 3	---
6A	Brown-2	---	14B	Gray 3	---
6B	Red 2	---	15A	White 3	---
7A	Orange 2	---	15B	Black 3	---
7B	Yellow 2	---	16A	Brown-4	---
8A	Green 2	---	16B	Red 4	---
8B	Blue 2	---	17A	Orange 4	---
9A	Purple 2	---	17B	Yellow 4	---

- Slider Type
- Mini
- Standard
- Controllers Integrated
- Robot Type
- Mini
- Standard
- Controllers Integrated
- Table/Arm /Flat Type
- Mini
- Standard
- Controller Integrated
- Gripper/ Rotary Type
- Linear Servo Type
- Cleanroom Type
- Splash-Proof
- Controllers
- PMEC /AMEC
- PSEP /ASEP
- ROBO NET
- ERC2
- PCON
- ACON
- SCON
- PSEL
- ASEL
- SSEL
- XSEL
- Pulse Motor
- Servo Motor (24V)
- Servo Motor (200V)
- Linear Servo Motor

- Slider Type
- Mini
- Standard
- Controllers Integrated
- Rod Type
- Mini
- Standard
- Controllers Integrated
- Table/Arm /Flat Type
- Mini
- Standard
- Gripper/ Rotary Type
- Linear Servo Type
- Cleanroom Type
- Splash-Proof
- Controllers
- PMEC /AMEC
- PSEP /ASEP
- ROBO NET
- ERC2
- PCON
- ACON
- SCON
- PSEL
- ASEL
- SSEL
- XSEL
- Pulse Motor
- Servo Motor (24V)
- Servo Motor (200V)
- Linear Servo Motor



List of models

Program controller for operating RCA2/RCA Series actuators. One unit can handle various controls.

Type	C	
Name	Program mode	Positioner Mode
External view		
Description	Both the actuator operation and communication with external equipment can be handled by a single controller. When two axes are connected, arc interpolation, path operations, and synchronization can be performed.	Up to 1500 positioning points are supported. Push-motion operation and teaching operation are also possible.
Position points	1500 points	
Number of control axes	Up to 2 axes	

Model

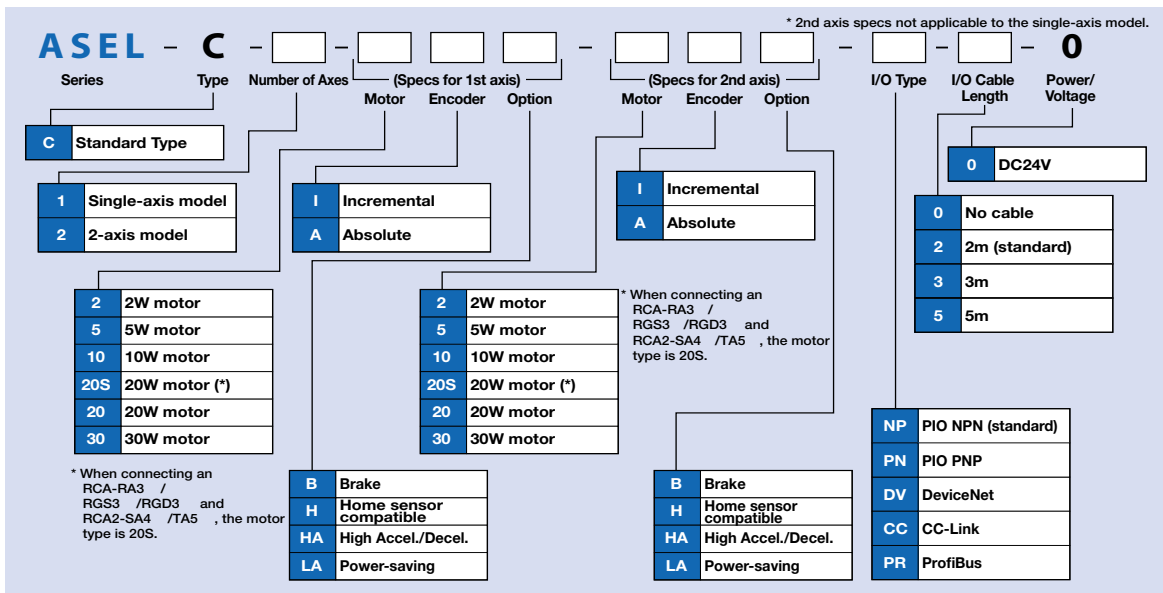

567

ASEL

System configuration

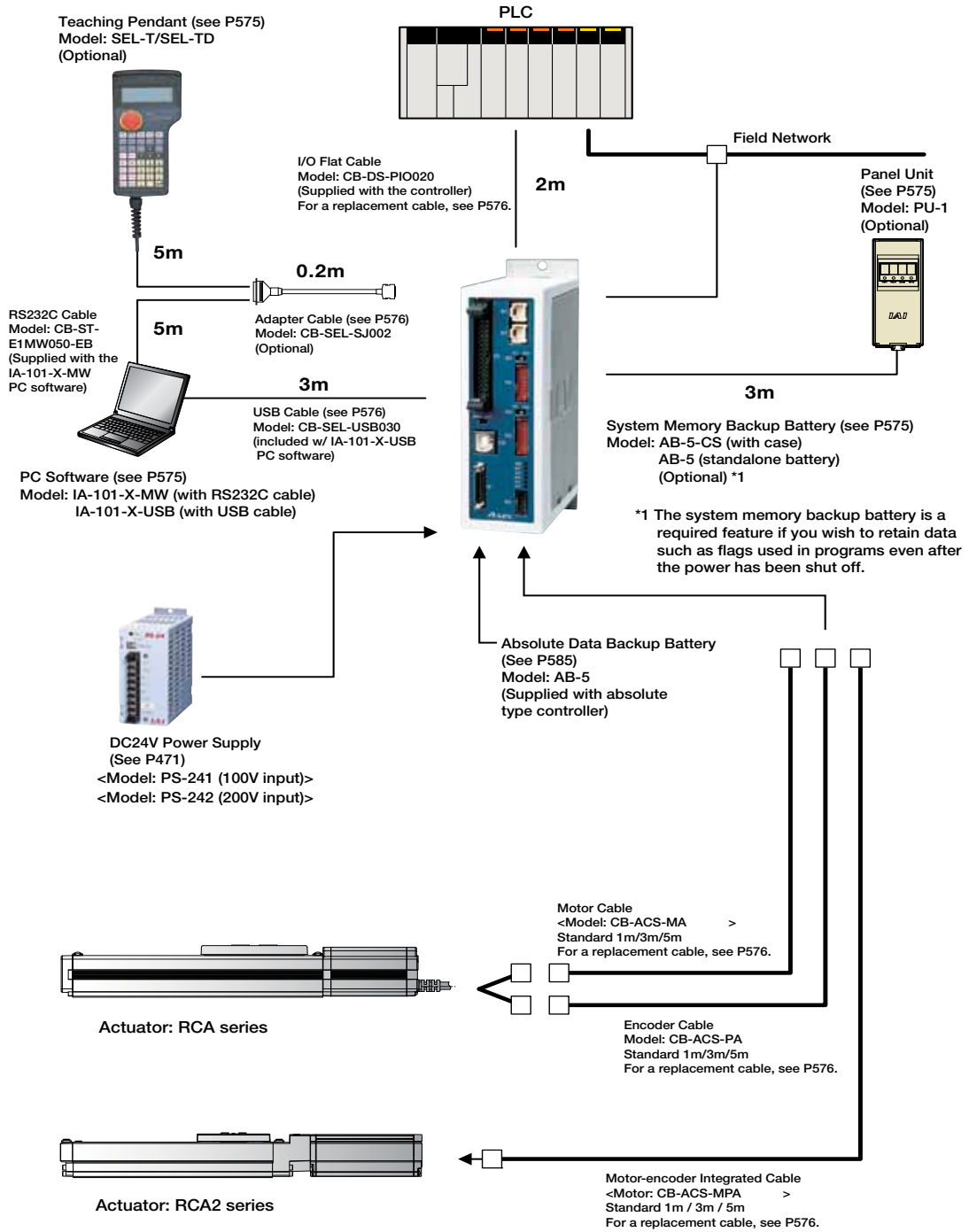

- Slider Type
- Mini
- Standard
- Controllers Integrated
- Rod Type
- Mini
- Standard
- Controllers Integrated
- Table/Arm /Flat Type
- Mini
- Standard
- Gripper/ Rotary Type
- Linear Servo Type
- Cleanroom Type
- Splash-Proof
- Controllers
- PMEC /AMEC
- PSEP /ASEP
- ROBO NET
- ERC2
- PCON
- ACON
- SCON
- PSEL
- ASEL
- SSEL
- XSEL
- Pulse Motor
- Servo Motor (24V)
- Servo Motor (200V)
- Linear Servo Motor

I/O Specifications

Input section External input specifications

Item	Specifications
Input voltage	DC24V ±10%
Input current	7mA / circuit
ON/OFF voltage	ON voltage (min.) NPN : DC16V / PNP : DC8V OFF voltage (max.) NPN : DC5V / PNP : DC19V
Isolation method	Photocoupler

NPN Specifications

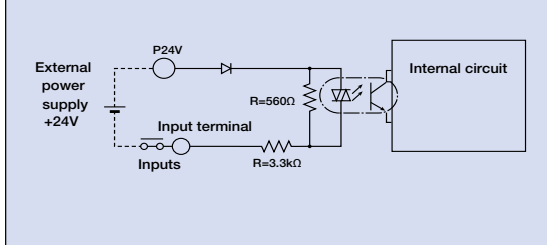

Output section External output specifications

Item	Specifications
Load Voltage	DC24V
Max. load current	100mA / 1 point 400mA / 8 points in total
Residual voltage (Max.)	Max 0.1mA / 1 point
Isolation method	Photocoupler

NPN Specifications

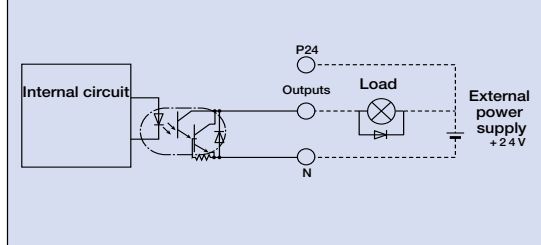

PNP Specifications

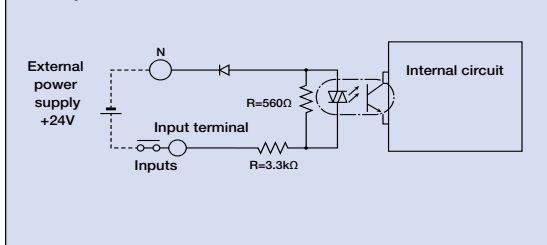

PNP Specifications

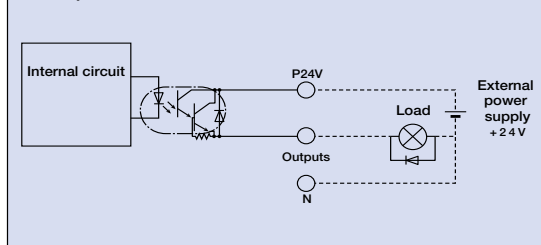

Explanation of I/O Signal Functions

Two modes can be selected for the ASEL controller: "Program Mode," in which the actuator is operated by entering a program, and "Positioner Mode," in which PLC signals are received and the actuator is moved to designated positions. The Positioner Mode has the five input patterns listed below to enable various applications.

Control Function by Type

Operation mode	Features
Program mode	Various operations including linear/arc interpolation operation, path operation ideal for coating processes, etc., arch-motion operation and palletizing operation can be performed using the Super SEL language that lets you program complex control actions using simple commands.
Positioner mode	Standard mode This is the basic mode from which operations can be conducted by designating position numbers and inputting the start signal. Push-motion operation and teaching operation are also possible.
	Product Change mode Multiple parts of the same shape with slightly different hole positions can be handled using movement commands to the same position numbers by simply changing the product type number.
	2-axis independent mode With a 2-axis controller, each axis can be commanded and operated separately.
	Teaching mode In this mode, the slider (rod) moves based on an external signal, when the actuator is stopped, the current location can be registered as position data.
	DS-S-C1 Compatible mode If you were using a DS-S-C1 controller, you can replace it with a ASEL controller without having to change the host programs. *This mode does not ensure actuator compatibility.

569

ASEL

- Slider Type
- Mini
- Standard
- Controllers Integrated
- Rod Type
- Mini
- Standard
- Controllers Integrated
- Table/Arm /Flat Type
- Mini
- Standard
- Gripper/ Rotary Type
- Linear Servo Type
- Cleanroom Type
- Splash-Proof
- Controllers
- PMEC /AMEC
- PSEP /ASEP
- ROBO NET
- ERC2
- PCON
- ACON
- SCON
- PSEL
- ASEL
- SSEL
- XSEL
- Pulse Motor
- Servo Motor (24V)
- Servo Motor (200V)
- Linear Servo Motor

Explanation of I/O Signal Functions

Program mode

Pin Number	Category	Port No.	Program Mode	Functions	Wiring Diagram			
1A	P24	016-022	24V input	Connect 24V.				
1B			Select Program No. 1	Selects the program number to start. (Input as BCD values to ports 016 to 022)				
2A			Select Program No. 2					
2B			Select Program No. 4					
3A			Select Program No. 8					
3B			Select Program No. 10					
4A			Select Program No. 20					
4B			Select Program No. 40					
5A			CPU reset		Resets the system to the same state as when the power is turned on.			
5B			Start		Starts the program selected by ports 016 to 022.			
6A			Input		001-015		General-purpose input	Waits for external input via program instructions.
6B							General-purpose input	
7A							General-purpose input	
7B	General-purpose input							
8A	General-purpose input							
8B	General-purpose input							
9A	General-purpose input							
9B	General-purpose input							
10A	General-purpose input							
10B	General-purpose input							
11A	Output	300-307	Alarm	Turns off when an alarm occurs. (Contact B)				
13B			Ready	Turns on when the controller starts up normally and is in an operable state.				
14A			General-purpose output	303-307	These outputs can be turned ON/OFF as desired via program instructions.			
14B								
15A								
15B								
16A								
16B	N	0V input	Connect 0V.					
17B								

Note: This is for NPN. PNP will be different.

Positioner mode

Pin Number	Category	Port No.	Positioner Standard Mode	Functions	Wiring Diagram	
1A	P24	016-022	24V input	Connect 24V.		
1B			Position input 10	Specifies the position numbers to move to, using port number 007 to 019. The number can be specified either as BCD or binary.		
2A			Position input 11			
2B			Position input 12			
3A			Position input 13			
3B			-			
4A			-			
4B			-			
5A			Error reset		Resets minor errors. (Severe errors require a restart.)	
5B			Start		Starts moving to the selected position.	
6A			Home Return		Performs Home Return.	
6B			Servo ON		Switches between Servo ON and OFF.	
7A			Push		Performs a push motion.	
7B	Pause	Pauses the motion when turned OFF, and resumes motion when turned ON.				
8A	Cancel	Stops the motion when turned OFF. The remaining motion is canceled.				
8B	Input	006-015	Interpolation settings	When this signal turned ON for a 2-axis model, the actuator moves by linear interpolation.		
9A			Position input 1	Specifies the position numbers to move to, using ports 007 to 019. The number can be specified either as BCD or binary.		
9B			Position input 2			
10A			Position input 3			
10B			Position input 4			
11A			Position input 5			
11B			Position input 6			
12A			Position input 7			
12B			Position input 8			
13A	Position input 9					
13B	Output	300-307	Alarm	Turns off when an alarm occurs. (Contact B)		
14A			Ready	Turns on when the controller starts up normally and is in an operable state.		
14B			Positioning complete	Turns on when the movement to the destination is complete.		
15A			Home Return complete	Turns on when the home return operation is complete.		
15B			Servo ON output	Turns on when servo is ON.		
16A			Pushing complete	Turns on when a push motion is complete.		
16B			System battery error	Turns on when the system battery runs low (warning level).		
17A	Absolute encoder battery error	Turns on when the battery for the absolute encoder runs low (warning level).				
17B	N	0V input	Connect 0V.			

Note: This is for NPN. PNP will be different.

- Slider Type
- Mini
- Standard
- Controllers Integrated
- Rod Type
- Mini
- Standard
- Controllers Integrated
- Table/Arm /Flat Type
- Mini
- Standard
- Gripper/ Rotary Type
- Linear Servo Type
- Cleanroom Type
- Splash-Proof
- Controllers
- PMEC /AMEC
- PSEP /ASEP
- ROBO NET
- ERC2
- PCON
- ACON
- SCON
- PSEL
- ASEL
- SSEL
- XSEL
- Pulse Motor
- Servo Motor (24V)
- Servo Motor (200V)
- Linear Servo Motor

ASEL 570

Explanation of I/O Signal Functions

Positioner, Product-Type Change Mode

Pin Number	Category	Port No.	Positioner Product Type Change Mode	Functions		
1A	P24	016	24V input	Connect 24V.		
1B			Position/Product Type Input 10	Specifies the position numbers to move to, and the product type numbers, using ports 007 to 022. The position and product type numbers are assigned by parameter settings. The number can be specified either as BCD or binary.		
2A			Position/Product Type Input 11			
2B			Position/Product Type Input 12			
3A			Position/Product Type Input 13			
3B			Position/Product Type Input 14			
4A			Position/Product Type Input 15			
4B			Position/Product Type Input 16			
5A			023		Error reset	Resets minor errors. (Severe errors require a restart.)
5B			000		Start	Starts moving to the selected position.
6A			001		Home Return	Performs Home Return.
6B			002		Servo ON	Switches between Servo ON and OFF.
7A			003		Push	Performs a push motion.
7B			004		Pause	Pauses the motion when turned OFF, and resumes motion when turned ON.
8A			005		Cancel	Stops the motion when turned OFF. The remaining motion is canceled.
8B			006		Interpolation settings	When this signal is turned ON for a 2-axis model, the actuator moves by linear interpolation.
9A	Input	007	Position/Product Type Input 1		Specifies the position numbers to move to, and the product type numbers, using ports 007 to 022. The position and product type numbers are assigned by parameter settings. The number can be specified either as BCD or binary.	
9B			Position/Product Type Input 2			
10A			Position/Product Type Input 3			
10B			Position/Product Type Input 4			
11A			Position/Product Type Input 5			
11B			Position/Product Type Input 6			
12A			Position/Product Type Input 7			
12B			Position/Product Type Input 8			
13A			015	Position/Product Type Input 9		
13B	Output	300	Alarm	Turns off when an alarm occurs (Contact B)		
14A			301	Ready	Turns on when the controller starts up normally and is in an operable state.	
14B			302	Positioning complete	Turns on when the movement to the destination is complete.	
15A			303	Home Return complete	Turns on when the home return operation is complete.	
15B			304	Servo ON output	Turns on when servo is ON.	
16A			305	Pushing complete	Turns on when a push motion is complete.	
16B			306	System battery error	Turns on when the system battery runs low (warning level).	
17A			307	Absolute encoder battery error	Turns on when the battery for the absolute encoder runs low (warning level).	
17B	N		0V input	Connect 0V.		

Wiring Diagram

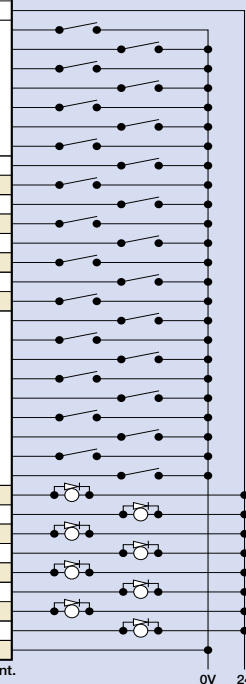

Note: This is for NPN. PNP will be different.

Positioner, 2-axis Independent Mode

Pin Number	Category	Port No.	Positioner 2-axis Independent Mode	Functions		
1A	P24	016	24V input	Connect 24V.		
1B			Position input 7	Specifies the position numbers to move to, using ports 010 to 022. The position numbers on the 1st and 2nd axes are assigned by parameter settings. The number can be specified either as BCD or binary.		
2A			Position input 8			
2B			Position input 9			
3A			Position input 10			
3B			Position input 11			
4A			Position input 12			
4B			Position input 13			
5A			023		Error reset	Resets minor errors. (Severe errors require a restart.)
5B			000		Start 1	Starts movement to the selected position number on the 1st axis.
6A			001		Home Return 1	Performs home return on the 1st axis.
6B			002		Servo ON 1	Switches between servo ON and OFF for the 1st axis.
7A			003		Pause 1	Pauses the motion on 1st axis when turned OFF, and resumes motion when turned ON.
7B	004	Cancel 1	Cancels the movement on the 1st axis.			
8A	005	Start 2	Starts the movement to the selected position number on the 2nd axis.			
8B	006	Home Return 2	Performs home return on the 2nd axis.			
9A	007	Servo ON 2	Switches between servo ON and OFF for the 2nd axis.			
9B	008	Pause 2	Pauses the motion on 2nd axis when turned OFF, and resumes when turned ON.			
10A	009	Cancel 2	Cancels the movement on the 2nd axis.			
10B	Input	010	Position input 1	Specifies the position numbers to move to, using ports 010 to 022. The position numbers on the 1st and 2nd axes are assigned by parameter settings. The number can be specified either as BCD or binary.		
11A			Position input 2			
11B			Position input 3			
12A			Position input 4			
12B			Position input 5			
13A			Position input 6			
13B	Output	300	Alarm	Turns off when an alarm occurs (Contact B)		
14A			301	Ready	Turns on when the controller starts up normally and is in an operable state.	
14B			302	Positioning complete 1	Turns on when the movement to the specified position on the 1st axis is complete.	
15A			303	Home Return complete 1	Turns on when home return on the 1st axis is complete.	
15B			304	Servo ON output 1	Turns on when the 1st axis is in a servo ON state.	
16A			305	Positioning complete 2	Turns on when the movement to the specified position on the 2nd axis is complete.	
16B			306	Home Return complete 2	Turns on when home return on the 2nd axis is complete.	
17A	307	Servo ON output 2	Turns on when the 2nd axis is in a servo ON state.			
17B	N		0V input	Connect 0V.		

Wiring Diagram

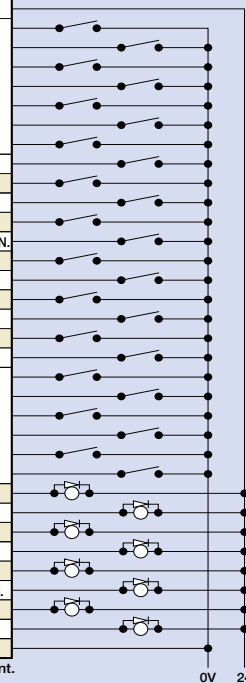

Note: This is for NPN. PNP will be different.

571

ASEL

- Slider Type
- Mini
- Standard
- Controllers Integrated
- Rod Type
- Mini
- Standard
- Controllers Integrated
- Table/Arm /Flat Type
- Mini
- Standard
- Gripper/ Rotary Type
- Linear Servo Type
- Cleanroom Type
- Splash-Proof
- Controllers
- PMEC /AMEC
- PSEP /ASEP
- ROBO NET
- ERC2
- PCON
- ACON
- SDON
- PSEL
- ASEL
- SSEL
- XSEL
- Pulse Motor
- Servo Motor (24V)
- Servo Motor (200V)
- Linear Servo Motor

Explanation of I/O Signal Functions

Positioner, Teaching Mode

Pin Number	Category	Port No.	Positioner Teaching Mode	Functions	Wiring Diagram		
1A	P24	016	24V input	Connect 24V.			
1B			JOG- on 1st axis	While the signal is on, the 1st axis is moved in the - (negative) direction.			
2A			JOG+ on 2nd axis	While the signal is on, the 2nd axis is moved in the + (positive) direction.			
2B			JOG- on 2nd axis	While the signal is on, the 2nd axis is moved in the - (negative) direction.			
3A			Specify inching (0.01mm)	020	Specify inching (0.1mm)		Specifies how much to move during inching. (Total of the values specified for ports 019 to 022)
3B							
4A							
4B							
4A			Specify inching (0.5mm)	021	Specify inching (1mm)		
4B							
5A							
5B							
5A			Input	023	Error reset		Resets minor errors. (Severe errors require a restart.)
5B				000	Start		Starts moving to selected position.
6A				001	Servo ON		Switches between Servo ON and OFF.
6B				002	Pause		Pauses the motion when turned OFF, and resumes motion when turned ON.
7A				Position input 1	003		Position input 2
7B							
8A							
8B							
9A							
9B							
10A							
10B							
11A							
11B							
12A	Position input 11	013				Teaching mode setting	
12B							
13A	Output	015		JOG+ on 1st axis	While the signal is input, the 1st axis is moved in the + (positive) direction.		
13B		300	Alarm	Turns off when an alarm occurs. (Contact B)			
14A		301	Ready	Turns on when the controller starts up normally and is in an operable state.			
14B		302	Positioning complete	Turns on when the movement to the destination is complete.			
15A		303	Home return complete	Turns on when the home return operation is complete.			
15B		304	Servo ON output	Turns on when servo is ON.			
16A		305	-	-			
16B		306	System battery error	Turns on when the system battery runs low (warning level).			
17A		307	Absolute encoder battery error	Turns on when the battery for the absolute encoder runs low (warning level).			
17B		N	0V input	Connect 0V.			

Note: This is for NPN. PNP will be different.

Positioner, DS-S-C1 Compatible Mode

Pin Number	Category	Port No.	Positioner DS-S-C1 Compatible Mode	Functions	Wiring Diagram			
1A	P24	016	24V input	Connect 24V.				
1B			Position No. 1000	(Same as ports 004 through 015)				
2A			-	-				
2B			-	-				
3A			-	-				
3B			-	-				
4A			-	-				
4B			-	-				
5A			Input	023	CPU reset		Resets the system to the same state as when the power is turned on.	
5B				000	Start		Starts moving to selected position.	
6A				001	Hold (Pause)		Pauses the motion when turned ON, and resumes when turned OFF.	
6B				002	Cancel		Stops the motion when turned ON. The remaining motion is canceled.	
7A				Interpolation settings	003		Position No. 1	When this signal is turned ON for a 2-axis model, the actuator moves by linear interpolation.
7B								
8A								
8B								
9A								
9B								
10A								
10B								
11A								
11B								
12A	Position No. 200	013				Position No. 400		
12B								
13A	Output	015		Position No. 800				
13B		300	Alarm	Turns off when an alarm occurs. (Contact A)				
14A		301	Ready	Turns on when the controller starts up normally and is in an operable state.				
14B		302	Positioning complete	Turns on when the movement to the destination is complete.				
15A		303	-	-				
15B		304	-	-				
16A		305	-	-				
16B		306	System battery error	Turns on when the system battery runs low (warning level).				
17A		307	Absolute encoder battery error	Turns on when the battery for the absolute encoder runs low (warning level).				
17B		N	0V input	Connect 0V.				

Note: This is for NPN. PNP will be different.

- Slider Type
- Mini
- Standard
- Controllers Integrated
- Rod Type
- Mini
- Standard
- Controllers Integrated
- Table/Arm /Flat Type
- Mini
- Standard
- Gripper/ Rotary Type
- Linear Servo Type
- Cleanroom Type
- Splash-Proof
- Controllers
- PMEC /AMEC
- PSEP /ASEP
- ROBO NET
- ERC2
- PCON
- ACON
- SCON
- PSEL
- ASEL
- SSEL
- XSEL
- Pulse Motor
- Servo Motor (24V)
- Servo Motor (200V)
- Linear Servo Motor

Table of specifications

	Item	Specifications
Basic Specifications	Connected actuator	RCA/RCA2 Series Actuator
	Input Voltage	DC24V ±10%
	Power Supply Capacity	Control power supply (Max. 1.2A) + motor power supply (See the table below)
	Dielectric strength voltage	DC500V 10MΩ or higher
	Withstand voltage	AC500V 1 min.
	Rush current	Max. 30A
	Vibration resistance	XYZ directions 10 to 57Hz, One side amplitude: 0.035mm (continuous), 0.075mm (intermittent) 58 to 150 Hz 4.9 m/s ² (continuous), 9.8 m/s ² (intermittent)
Control specification	Number of control axes	1 axis / 2 axis
	Maximum total output of connected axis	60W (30W + 30W)
	Position detection method	Incremental encoder / Absolute encoder
	Speed setting	1mm/sec and up, the maximum depends on actuator specifications
	Acceleration setting	0.01G and up, the maximum depends on the actuator
	Operating method	Program operation / Positioner operation (switchable)
Program	Programming language	Super SEL language
	Number of programs	64 programs
	Number of program steps	2000 steps
	Number of multi-tasking programs	8 points
	Positioning Points	1500 points
	Data memory device	FLASHROM (A system-memory backup battery can be added as an option)
Communication	Data input method	Teaching pendant or PC software
	Number of I/O	24 input points / 8 output points (NPN or PNP selectable)
	I/O power	Externally supplied 24VDC ± 10%
	PIO cable	CB-DS-PIO □□□ (supplied with the controller)
	Serial communications function	RS232C (D-Sub Half-pitch connector) / USB connector
	Field Network	DeviceNet, CC-Link, ProfiBus
	Motor Cable	CB-ACS-MA □□□ (Max. 20m)
	Encoder cable	CB-ACS-PA □□□ (Max. 20m)
General specifications	Protection function	Motor overcurrent, Motor driver temperature check, Overload check, Encoder open-circuit check Soft limit over, system error, battery error, etc.
	Ambient operating humidity and temperature	0 to 40°C 10 to 95% (non-condensing)
	Ambient atmosphere	Free from corrosive gases. In particular, there shall be no significant dust.
	Protection class	IP20
	Weight	Approx. 450g
	External dimensions	43 mm (W) x 159 mm (H) x 110 mm (D)

Actuator type	1-Axis specification				2-Axis specification				
	Standard specifications/high acceleration and deceleration model		Power-saving		Standard specifications/high acceleration and deceleration model		Power-saving		
	Rated	Max. (Note2)	Rated	Max. (Note3)	Rated	Max. (Note2)	Rated	Max. (Note3)	
RCA RCA2	10W, 20W [Model symbol: 20]	1.3A	4.4A	1.3A	2.5A	2.6A	8.8A	2.6A	5.0A
	30W	1.3A	4.4A	1.3A	2.2A	2.6A	8.8A	2.6A	4.4A
	20W [Model symbol: 20S] SA4, RA3, TA5 type dedicated	1.7A	5.1A	1.7A	3.4A	3.4A	10.2A	3.4A	6.8A
RCL	2W	0.8A	4.6A	-	-	1.6A	9.2A	-	-
	5W	1.0A	6.4A	-	-	2.0A	12.8A	-	-
	10W	1.3A	6.4A	-	-	2.6A	12.8A	-	-

(Note 1) For both 1-axis and 2-axis specifications, approx. 30.0A inrush current flows for 5 ms when the control power supply is turned on.

(Note 2) Max. current at accelerating/decelerating

(Note 3) Current reaches the maximum when detecting the servo motor excitation phase at the first servo on after the power is on. (Normal: Approx. 1 to 2 sec., Max.: 10 sec)

(Note 4) Other than motor power supply capacity, it increases 0.5A for control power.

External Dimensions

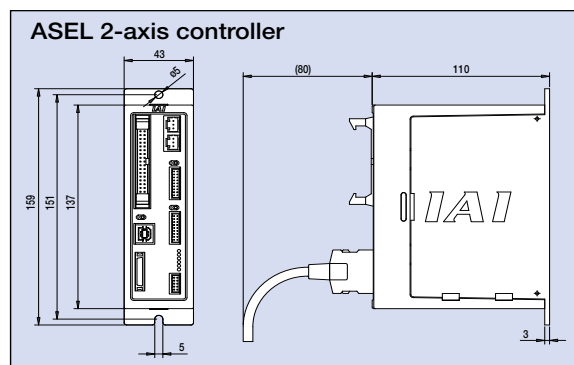
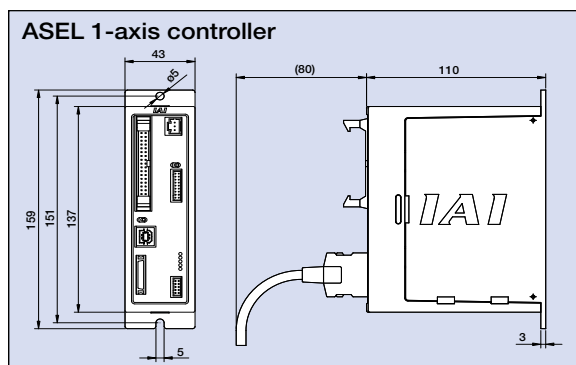

573

ASEL

Name of Each Part

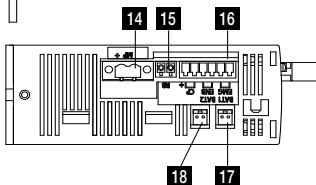
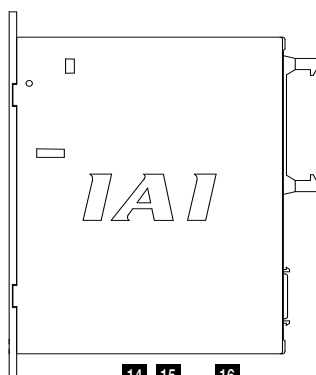
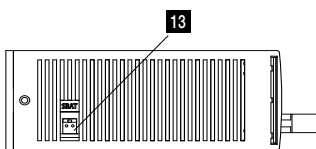
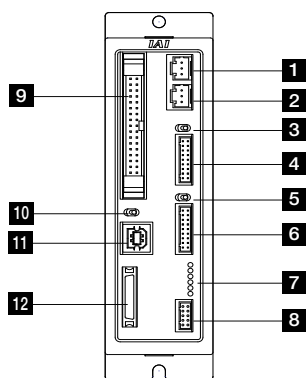

1 Motor connector for axis 1

Connect the motor cable of the axis 1 actuator.

2 Motor connector for axis 2

Connect the motor cable of the axis 2 actuator.

3 Brake switch for axis 1

This switch is used to release the axis brake. Setting it to the left position (RLS side) forcibly releases the brake, while setting it to the right position (NOM side) causes the controller to automatically control the brake.

4 Encoder connector for axis 1

Connect the encoder cable of the axis 1 actuator.

5 Brake switch for axis 2

This switch is used to release the axis brake.

Setting it to the left position (RLS side) forcibly releases the brake, while setting it to the right position (NOM side) causes the controller to automatically control the brake.

6 Encoder connector for axis 2

Connect the encoder cable of the axis 2 actuator.

7 Status indicator LEDs

These LEDs are used to indicate the operating condition of the controller.

The LED status indicators are as follows:

- PWR : Power is input to controller.
- RDY : The controller is ready to perform program operation.
- ALM : The controller is abnormal.
- EMG : An emergency stop is actuated and the drive source is cut off.
- SV1 : The axis 1 actuator servo is on.
- SV2 : The axis 2 actuator servo is on.

8 Panel unit connector

A connector for the panel unit (optional) that displays the controller status and error codes.

9 I/O Connector

A connector for interface I/Os.

34-pin flat cable connector for DIO (24IN/8OUT) interface.

I/O power is also supplied to the controller via this connector (Pin No. 1 and No. 34).

10 Mode switch

This switch is used to specify the running mode of the controller. The left position indicates the MANU (manual operation) mode, while the right position indicates the AUTO (automatic operation) mode. Teaching can only be performed in manual operation, and automatic operation using external I/Os is not possible in the MANU mode.

11 USB connector

A connector for PC connection via USB. If the USB connector is connected, the TP connector is disabled and all communication inputs to the TP connector are cut off.

12 Teaching pendant connector

A half-pitch I/O 26-pin connector that connects a teaching pendant when the running mode is MANU. A special conversion cable is needed to connect a conventional Dsub, 25-pin connector.

13 System-memory backup battery connector

If you wish to retain the various data recorded in the SRAM of the controller even after the power is cut off, connect the necessary battery to this connector. This battery is installed externally to the unit. The controller does not come standard with the battery (Option).

14 Motor power input connector

This connector is used to input the motor power. It consists of a 2-pin, 2-piece connector by Phoenix Contact.

15 External regenerative resistor connector

A connector for the regenerative resistor that must be connected when the built-in regenerative resistor alone does not offer sufficient capacity in high-acceleration/high-load operation, etc.

Whether or not an external regenerative resistor is necessary depends on the conditions of your specific application such as the axis configuration.

16 Control power/System input connector

This connector is used to connect the control power input, emergency stop switch, and enable switch. It consists of a Phoenix Contact 6-pin 2-piece connector.

17 Absolute-data backup battery connector for axis 1

A connector for the battery that backs up absolute data when the actuator uses an absolute encoder. Secure installation of the battery is the customer's responsibility.

18 Absolute-data backup battery connector for axis 2

A connector for the battery that backs up absolute data when the actuator uses an absolute encoder. Secure installation of the battery is the customer's responsibility.

- Slider Type
- Mini
- Standard
- Controllers Integrated
- Rod Type
- Mini
- Standard
- Controllers Integrated
- Table/Arm /Flat Type
- Mini
- Standard
- Cripper/ Rotary Type
- Linear Servo Type
- Cleanroom Type
- Splash-Proof
- Controllers
- PMEC /AMEC
- PSEP /ASEP
- ROBO NET
- ERC2
- PCON
- ACON
- SCON
- PSEL
- ASEL
- SSEL
- XSEL

- Pulse Motor
- Servo Motor (24V)
- Servo Motor (200V)
- Linear Servo Motor

Option

Teaching Pendant

Features This is a teaching device that provides information on functions such as position input, test runs, and monitoring.

Model

Model	Description
SEL-T-J	Standard type with adapter cable
SEL-TD-J	Equipped with a deadman switch and adapter cable

Configuration

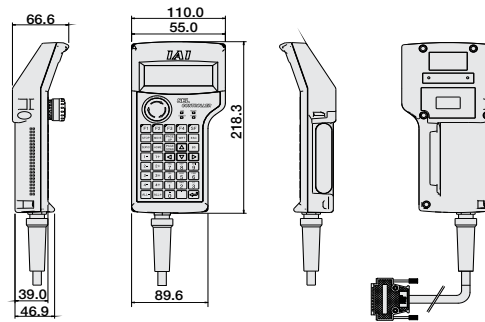
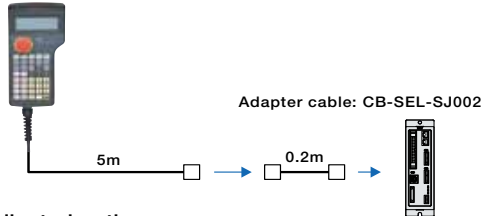

SEL-T dedicated options

- Wall-mounting hook Model HK-1
- Strap Model STR-1



Specifications

Item	SEL-T-J	SEL-TD-J
3-position Enable Switch	No	Yes
ANSI/UL standards	Non-compliant	Compliant
CE mark	Compliant	
Display	20 char. x 4 lines	
Ambient Operating Temp./Humidity	0-40°C 10-90% RH (non-condensing)	
Protective structure	IP54	
Weight	Approx. 0.4kg (not incl. cable)	

PC Software (Windows Only)

Features A startup support software for entering programs/positions, performing test runs, and monitoring. More functions have been added for debugging, and improvements have been made to shorten the start-up time.

Model IA-101-X-MW-J (with RS232C cable + adapter cable)

Configuration

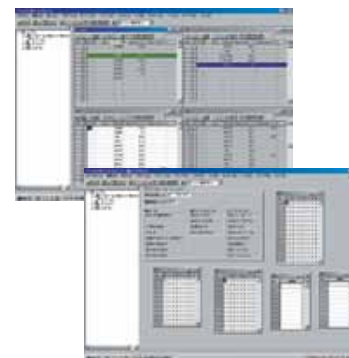
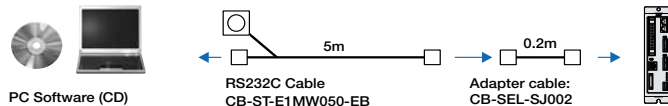

Model IA-101-X-USB (with USB cable)

Configuration

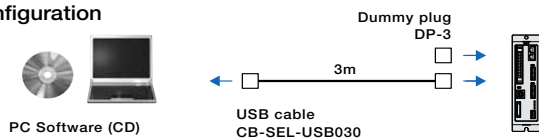

Note:
Only versions 7.0.0.0 and later can be used with the PSEL controller.

Panel Unit

Features Display device that shows the error code from the controller or the currently running program number.

Model PU-1 (Cable length: 3m)

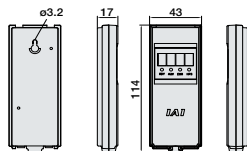

Absolute Data Backup Battery

Features Battery for saving absolute data, when operating an actuator with an absolute encoder. Same as the battery used for system memory backup.

Model AB-5



System Memory Backup Battery

Features This battery is required when you are using global flags in the program and you want to retain your data even after the power has been turned OFF.

Model AB-5-CS (with case)
AB-5 (Standalone battery)



575

ASEL

- Slider Type
- Mini
- Standard
- Controllers Integrated
- Rod Type
- Mini
- Standard
- Controllers Integrated
- Table/Arm/Flat Type
- Mini
- Standard
- Gripper/Rotary Type
- Linear Servo Type
- Cleanroom Type
- Splash-Proof
- Controllers
- PMEC/AMEC
- PSEP/ASEP
- ROBO NET
- ERC2
- PCON
- ACON
- SCON
- PSEL
- ASEL
- SSEL
- XSEL
- Pulse Motor
- Servo Motor (24V)
- Servo Motor (200V)
- Linear Servo Motor

Option

Dummy Plug

Features When connecting the ASEL controller to a computer with a USB cable, this plug is inserted in the teaching port to shut off the enable circuit.
(Supplied with the PC software IA-101-X-USB)

Model DP-3



USB Cable

Features A cable for connecting the controller to the USB port to a computer. A controller with no USB port (e.g. XSEL) can be connected to the USB port of a computer by connecting an RS232C cable to the USB cable via a USB adapter.
(See PC software IA-101-X-USBMW)

Model CB-SEL-USB030 (Cable length: 3m)



Adapter Cable

Features An adapter cable to connect the D-sub 25-pin connector from the teaching pendant or a PC to the teaching connector (half-pitch) of the ASEL controller.

Model CB-SEL-SJ002 (Cable length: 0.2m)



Spare Parts

When you need spare parts after purchasing the product, such as when replacing a cable, refer to the list of models below.

Motor cable

Model CB-ACS-MA

* The standard motor cable is a robot cable.

* Enter the cable length (L) into . Compatible to a maximum of 20 meters.
Ex.: 080 = 8 m

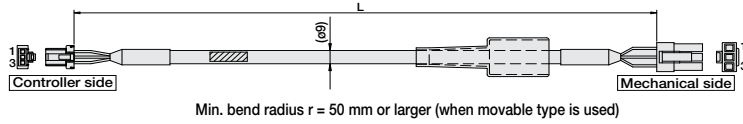

Wire	Color	Signal/Pin No.
Red	U	1
White	V	2
Black	W	3

Pin No.	Signal	Color	Wire
1	ENA	Gray	White/Blue
2	ENB	Red	White/Yellow
3	ENB	Black	White/Red
4	ENB	Yellow	White/Black
5	—	—	—
6	—	—	—
7	LS-	Blue	White/Purple
8	—	—	—
9	FG	Ground	Ground
10	ENZ	Pink	Orange
11	ENZ	Purple	Green
12	—	—	—
13	VPS	White	Purple
14	SV	Blue/Red	Gray
15	GND	Green/White	Red
16	LS	Orange	White/Gray
17	BK-	Brown	Blue
18	BK+	Green	Yellow
19	Ground	F.G	1

Encoder cable/Encoder robot cable

Model CB-ACS-PA / CB-ACS-PA -RB

* The standard cable for the encoder cable is a normal cable. * Enter the cable length (L) into . Compatible to a maximum of 20 meters.
A robot cable can be specified as an option. Ex.: 080 = 8 m

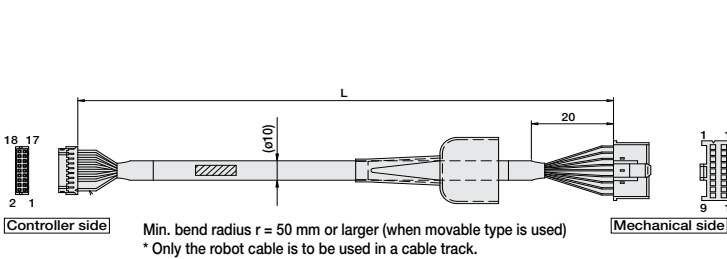

Cable color	Signal	Pin No.	
Robot Cable	LS+	13	
White/Purple	LS-	17	
White/Gray	LS+	18	
Yellow	LS-	15	
Blue	BK-	15	
Blue	BK-	15	
White/Blue	ENA	14	
White/Yellow	ENB	13	
White/Red	ENB	12	
White/Black	ENB	11	
Orange	ENZ	10	
Green	ENZ	9	
Purple	White	8	
Gray	Blue/red	7	
Red	Orange/White	6	
Black	GND	5	
—	—	4	
—	—	3	
—	—	2	
—	—	1	
Ground	Ground	F.G	1

Pin No.	Signal	Cable color
1	ENA	Gray
2	ENB	Red
3	ENB	Black
4	ENB	Yellow
5	—	—
6	—	—
7	LS-	Blue
8	—	—
9	FG	Ground
10	ENZ	Pink
11	ENZ	Purple
12	—	—
13	VPS	White
14	SV	Blue/Red
15	GND	Green/White
16	LS	Orange
17	BK-	Brown
18	BK+	Green

Housing : PHDR-18VR (JST)
Contact : SPHD-0011-PO.5 (JST)
Plug housing : XMP-18V (JST)
Socket contact : BXA-0011-PO.6 (JST)
Retainer : XMS-09V (SST)

Motor-Encoder Integrated Cable for RCA2

Model CB-ACS-MPA

* Enter the cable length (L) into . Compatible to a maximum of 20 meters.
Ex.: 080 = 8 m

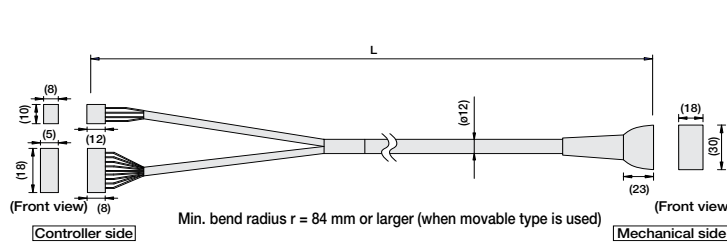

Signal	Pin No.	(Wire color)	Pin No.	Signal
U	1	Red	A1	U
V	2	Yellow	B1	V
W	3	Black	B2	W
			B3	NC
			B4	NC
			B5	NC
			B6	NC
			B7	NC
			B8	NC
			B9	NC
			B10	NC
			B11	NC
			B12	NC
			B13	NC
			B14	NC
			B15	NC
			B16	NC
			B17	NC
			B18	NC
			B19	NC
			B20	NC
			B21	NC
			B22	NC
			B23	NC
			B24	NC
			B25	NC
			B26	NC
			B27	NC
			B28	NC
			B29	NC
			B30	NC
			B31	NC
			B32	NC
			B33	NC
			B34	NC
			B35	NC
			B36	NC
			B37	NC
			B38	NC
			B39	NC
			B40	NC
			B41	NC
			B42	NC
			B43	NC
			B44	NC
			B45	NC
			B46	NC
			B47	NC
			B48	NC
			B49	NC
			B50	NC
			B51	NC
			B52	NC
			B53	NC
			B54	NC
			B55	NC
			B56	NC
			B57	NC
			B58	NC
			B59	NC
			B60	NC
			B61	NC
			B62	NC
			B63	NC
			B64	NC
			B65	NC
			B66	NC
			B67	NC
			B68	NC
			B69	NC
			B70	NC
			B71	NC
			B72	NC
			B73	NC
			B74	NC
			B75	NC
			B76	NC
			B77	NC
			B78	NC
			B79	NC
			B80	NC
			B81	NC
			B82	NC
			B83	NC
			B84	NC
			B85	NC
			B86	NC
			B87	NC
			B88	NC
			B89	NC
			B90	NC
			B91	NC
			B92	NC
			B93	NC
			B94	NC
			B95	NC
			B96	NC
			B97	NC
			B98	NC
			B99	NC
			B100	NC

I/O Flat Cable

Model CB-DS-PIO

* Enter the cable length (L) into . Compatible to a maximum of 10 meters.
Ex.: 080 = 8 m

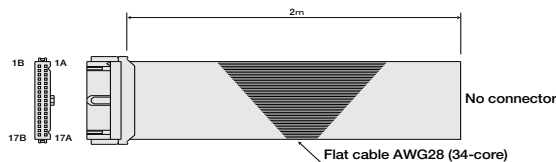

Pin No.	Color	Wire	Pin No.	Color	Wire
1A	Brown 1	9B	Gray 2	10A	White 2
1B	Red 1	10A	White 2	10B	Black 2
2A	Orange 1	11A	Brown-3	11B	Red 3
2B	Yellow 1	12A	Orange 3	12B	Yellow 3
3A	Green 1	13A	Green 3	13B	Blue 3
3B	Blue 1	14A	Purple 3	14B	Gray 3
4A	Purple 1	15A	White 3	15B	Black 3
4B	Gray 1	16A	Brown-4	16B	Red 4
5A	White 1	17A	Orange 4	17B	Yellow 4
5B	Black 1	17B	Yellow 4		
6A	Brown-2				
6B	Red 2				
7A	Orange 2				
7B	Yellow 2				
8A	Green 2				
8B	Blue 2				
9A	Purple 2				

576

ASEL

- Slider Type
- Mini
- Standard
- Controllers Integrated
- Rod Type
- Mini
- Standard
- Controllers Integrated
- Table/Arm /Flat Type
- Mini
- Standard
- Cripper/ Rotary Type
- Linear Servo Type
- Cleanroom Type
- Splash-Proof
- Controllers
- PMEC /AMEC
- PSEP /ASEP
- ROBO NET
- ERC2
- PC0N
- AC0N
- SC0N
- PSEL
- ASEL
- SSEL
- XSEL
- Pulse Motor
- Servo Motor (24V)
- Servo Motor (200V)
- Linear Servo Motor

System configuration

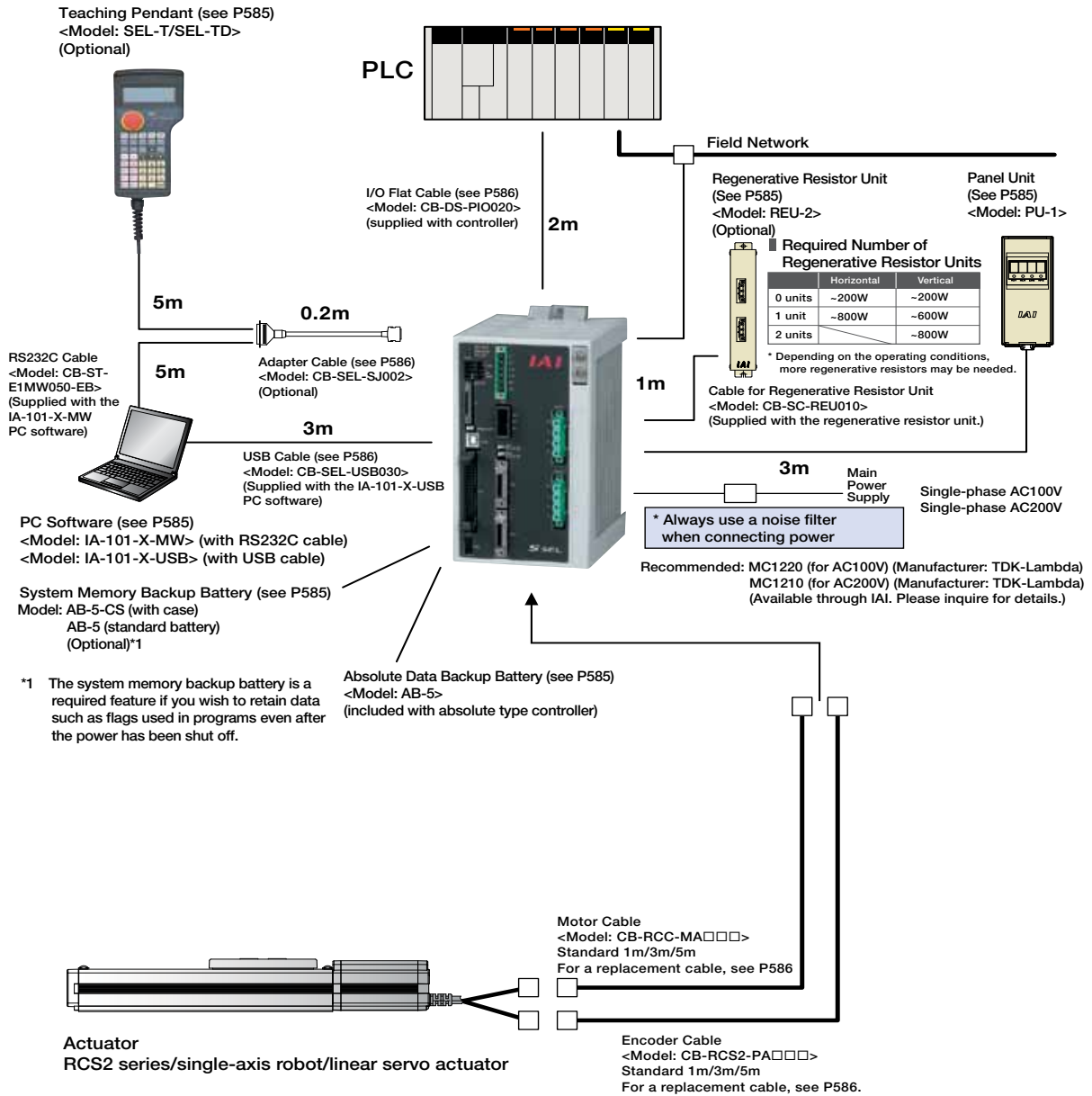

- Slider Type
- Mini
- Standard
- Controllers Integrated
- Rod Type
- Mini
- Standard
- Controllers Integrated
- Table/Arm /Flat Type
- Mini
- Standard
- Gripper/ Rotary Type
- Linear Servo Type
- Cleanroom Type
- Splash-Proof
- Controllers
- PMEC /AMEC
- PSEP /ASEP
- ROBO NET
- ERC2
- PCON
- ACON
- SCON
- PSEL
- ASEL
- SSEL
- XSEL
- Pulse Motor
- Servo Motor (24V)
- Servo Motor (200V)
- Linear Servo Motor

I/O Specifications

Input section External input specifications

Item	Specifications
Input voltage	DC24V ±10%
Input current	7mA / circuit
ON/OFF voltage	ON voltage (min.) NPN : DC16V / PNP : DC8V OFF voltage (max.) NPN : DC5V / PNP : DC19V
Isolation method	Photocoupler

NPN Specifications

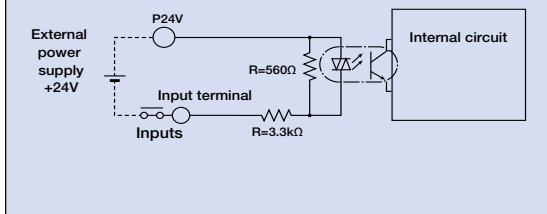

Output section External output specifications

Item	Specifications
Load Voltage	DC24V
Max. load current	100mA / 1point 400mA / 8 points in total
Residual voltage (Max.)	Max 0.1mA / 1 point
Isolation method	Photocoupler

NPN Specifications

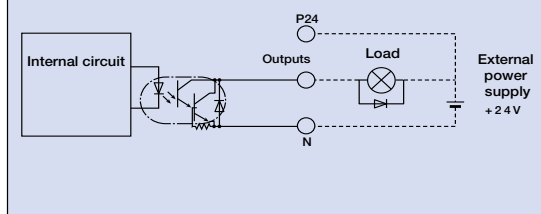

PNP Specifications

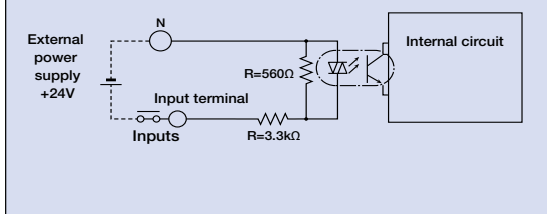

PNP Specifications

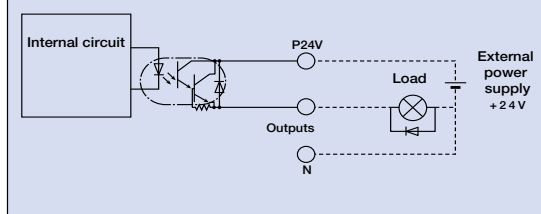

Explanation of I/O Signal Functions

Two modes can be selected for the SSEL controller: "Program Mode," in which the actuator is operated by entering a program, and "Positioner Mode," in which PLC signals are received and the actuator is moved to designated positions. The Positioner Mode has the five input patterns listed below to enable various applications.

Control Function by Type

Operation mode	Features
Program mode	Various operations including linear/arc interpolation operation, path operation ideal for coating processes, etc., arch-motion operation and palletizing operation can be performed using the Super SEL language that lets you program complex control actions using simple commands.
Positioner mode	Standard mode This is the basic mode from which operations can be conducted by designating position numbers and inputting the start signal. Push-motion operation and teaching operation are also possible.
	Product change mode Multiple parts of the same shape with slightly different hole positions can be handled using movement commands to the same position numbers by simply changing the product type number.
	2-axis independent mode With a 2-axis controller, each axis can be commanded and operated separately.
	Teaching mode In this mode, the slider (rod) moves based on an external signal, when the actuator is stopped, the current position can be registered as position data.
	DS-S-C1 Compatible mode If you were using a DS-S-C1 controller, you can replace it with a SSEL controller without having to change the host programs. *This mode does not ensure actuator compatibility.

579 SSEL

Explanation of I/O Signal Functions

Program mode

Pin Number	Category	Port No.	Program Mode	Functions	Wiring Diagram			
1A	P24	016-022	24V input	Connect 24V.				
1B			Select Program No. 1	Selects the program number to start. (Input as BCD values to ports 016 to 022)				
2A			Select Program No. 2					
2B			Select Program No. 4					
3A			Select Program No. 8					
3B			Select Program No. 10					
4A			Select Program No. 20					
4B			Select Program No. 40					
5A			CPU reset		Resets the system to the same state as when the power is turned on.			
5B			Start		Starts the programs selected by ports 016 to 022.			
6A			Input		001		General-purpose input	Waits for external input via program instructions.
6B					002		General-purpose input	
7A					003		General-purpose input	
7B					004		General-purpose input	
8A					005		General-purpose input	
8B					006		General-purpose input	
9A					007		General-purpose input	
9B	008	General-purpose input						
10A	009	General-purpose input						
10B	010	General-purpose input						
11A	011	General-purpose input						
11B	012	General-purpose input						
12A	013	General-purpose input						
12B	014	General-purpose input						
13A	015	General-purpose input						
13B	Output	300	Alarm	Turns off when an alarm occurs. (Contact B)				
14A		301	Ready	Turns on when the controller starts up normally and is in an operable state.				
14B		302	General-purpose output	These outputs can be turned ON/OFF as desired via program instructions.				
15A		303	General-purpose output					
15B		304	General-purpose output					
16A		305	General-purpose output					
16B		306	General-purpose output					
17A	307	General-purpose output						
17B	N		0V input	Connect 0V.				

Note: This is for NPN. PNP will be different.

Positioner mode

Pin Number	Category	Port No.	Positioner Standard Mode	Functions	Wiring Diagram			
1A	P24	016-022	24V input	Connect 24V.				
1B			Position input 10	Specifies the position numbers to move to, using port number 007 to 019. The number can be specified either as BCD or binary.				
2A			Position input 11					
2B			Position input 12					
3A			Position input 13					
3B			Position input 14					
4A			Position input 15					
4B			Position input 16					
5A			Error reset		Resets minor errors. (Severe errors require a restart.)			
5B			Start		Starts moving to selected position.			
6A			Input		001		Home Return	Performs home return.
6B					002		Servo ON	Switches between Servo ON and OFF.
7A					003		Push	Performs a push motion.
7B					004		Pause	Pauses the motion when turned OFF, and resumes motion when turned ON.
8A					005		Cancel	Stops the motion when turned OFF. The remaining motion is canceled.
8B					Interpolation setting		When this signal is turned ON for a 2-axis model, the actuator moves by linear interpolation.	
9A					007		Position input 1	Specifies the position numbers to move to, using ports 007 to 019. The number can be specified either as BCD or binary.
9B	008	Position input 2						
10A	009	Position input 3						
10B	010	Position input 4						
11A	011	Position input 5						
11B	012	Position input 6						
12A	013	Position input 7						
12B	014	Position input 8						
13A	015	Position input 9						
13B	Output	300	Alarm	Turns off when an alarm occurs. (Contact B)				
14A		301	Ready	Turns on when the controller starts up normally and is in an operable state.				
14B		302	Positioning complete	Turns on when the movement to the destination is complete.				
15A		303	Home Return complete	Turns on when the home return operation is complete.				
15B		304	Servo ON output	Turns on when servo is ON.				
16A		305	Pushing complete	Turns on when a push motion is complete.				
16B		306	System battery error	Turns on when the system battery runs low (warning level).				
17A	307	Absolute encoder battery error	Turns on when the battery for the absolute encoder runs low (warning level).					
17B	N		0V input	Connect 0V.				

Note: This is for NPN. PNP will be different.

- Slider Type
- Mini
- Standard
- Controllers Integrated
- Rod Type
- Mini
- Standard
- Controllers Integrated
- Table/Arm /Flat Type
- Mini
- Standard
- Gripper/ Rotary Type
- Linear Servo Type
- Cleanroom Type
- Splash-Proof
- Controllers
- PMEC /AMEC
- PSEP /ASEP
- ROBO NET
- ERC2
- PCON
- ACON
- SCON
- PSEL
- ASEL
- SSEL
- XSEL
- Pulse Motor
- Servo Motor (24V)
- Servo Motor (200V)
- Linear Servo Motor

SSEL **580**

Explanation of I/O Signal Functions

Positioner, Product-Type Change Mode

Pin Number	Category	Port No.	Positioner Product Type Change Mode	Functions		
1A	P24		24V input	Connect 24V.		
1B		016	Position/Product Type Input 10	Specifies the position numbers to move to, and the product type numbers, using ports 007 to 022. The position and product type numbers are assigned by parameter settings. The number can be specified either as BCD or binary.		
2A		017	Position/Product Type Input 11			
2B		018	Position/Product Type Input 12			
3A		019	Position/Product Type Input 13			
3B		020	Position/Product Type Input 14			
4A		021	Position/Product Type Input 15			
4B		022	Position/Product Type Input 16			
5A		023	Error reset		Resets minor errors. (Severe errors require a restart.)	
5B		000	Start		Starts moving to selected position.	
6A		001	Home Return		Performs home return.	
6B		002	Servo ON		Switches between Servo ON and OFF.	
7A		003	Push		Performs a push motion.	
7B		004	Pause		Pauses the motion when turned OFF, and resumes motion when turned ON.	
8A		005	Cancel		Stops the motion when turned OFF. The remaining motion is canceled.	
8B		006	Interpolation setting		When this signal is turned ON for a 2-axis model, the actuator moves by linear interpolation.	
9A	Input	007	Position/Product Type Input 1		Specifies the position numbers to move to, and the product type numbers, using ports 007 to 022. The position and product type numbers are assigned by parameter settings. The number can be specified either as BCD or binary.	
9B		008	Position/Product Type Input 2			
10A		009	Position/Product Type Input 3			
10B		010	Position/Product Type Input 4			
11A		011	Position/Product Type Input 5			
11B		012	Position/Product Type Input 6			
12A		013	Position/Product Type Input 7			
12B		014	Position/Product Type Input 8			
13A		015	Position/Product Type Input 9			
13B		300	Alarm	Turns off when an alarm occurs. (Contact B)		
14A		301	Ready	Turns on when the controller starts up normally and is in an operable state.		
14B		302	Positioning complete	Turns on when the movement to the destination is complete.		
15A		Output	303	Home Return complete		Turns on when the home return operation is complete.
15B			304	Servo ON output		Turns on when servo is ON.
16A			305	Pushing complete		Turns on when a push motion is complete.
16B			306	System battery error		Turns on when the system battery runs low (warning level).
17A	307		Absolute encoder battery error	Turns on when the battery for the absolute encoder runs low (warning level).		
17B	N		0V input	Connect 0V.		

Wiring Diagram

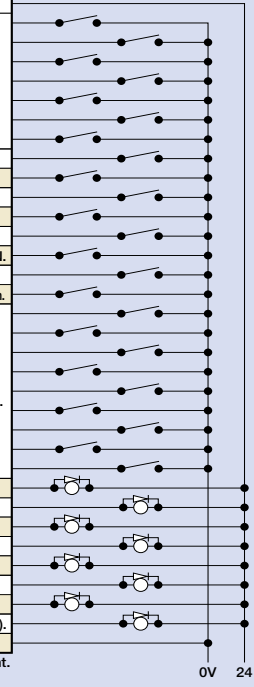

Note: This is for NPN. PNP will be different.

Positioner, 2-axis Independent Mode

Pin Number	Category	Port No.	Positioner Independent Mode	Functions	
1A	P24		24V input	Connect 24V.	
1B		016	Position input 7	Specifies the position numbers to move to, using ports 010 to 022. The position numbers on the 1st and 2nd axes are assigned by parameter settings. The number can be specified either as BCD or binary.	
2A		017	Position input 8		
2B		018	Position input 9		
3A		019	Position input 10		
3B		020	Position input 11		
4A		021	Position input 12		
4B		022	Position input 13		
5A		023	Error reset		Resets minor errors. (Severe errors require a restart.)
5B		000	Start 1		Starts the movement to the selected position number on the 1st axis.
6A		001	Home Return 1		Performs Home Return on the 1st axis.
6B		002	Servo ON 1		Switches between servo ON and OFF for the 1st axis.
7A		003	Pause 1		Pauses the motion on 1st axis when turned OFF, and resumes when turned ON.
7B	004	Cancel 1	Cancels the movement on the 1st axis.		
8A	Input	005	Start 2	Starts the movement to the selected position number on the 2nd axis.	
8B		006	Home Return 2	Performs Home Return on the 2nd axis.	
9A		007	Servo ON 2	Switches between servo ON and OFF for the 2nd axis.	
9B		008	Pause 2	Pauses the motion on 2nd axis when turned OFF, and resumes when turned ON.	
10A		009	Cancel 2	Cancels the movement on the 2nd axis.	
10B		010	Position input 1	Specifies the position numbers to move to, using ports 010 to 022. The position numbers on the 1st and 2nd axes are assigned by parameter settings. The number can be specified either as BCD or binary.	
11A	011	Position input 2			
11B	012	Position input 3			
12A	013	Position input 4			
12B	014	Position input 5			
13A	015	Position input 6			
13B	Output	300	Alarm	Turns off when an alarm occurs. (Contact B)	
14A		301	Ready	Turns on when the controller starts up normally and is in an operable state.	
14B		302	Positioning complete 1	Turns on when the movement to the specified position on the 1st axis is complete.	
15A		303	Home Return complete 1	Turns on when home return on the 1st axis is complete.	
15B		304	Servo ON output 1	Turns on when the 1st axis is in a servo ON state.	
16A		305	Positioning complete 2	Turns on when the movement to the specified position on the 2nd axis is complete.	
16B	306	Home Return complete 2	Turns on when home return on the 2nd axis is complete.		
17A		307	Servo ON output 2	Turns on when the 2nd axis is in a servo ON state.	
17B	N		0V input	Connect 0V.	

Wiring Diagram

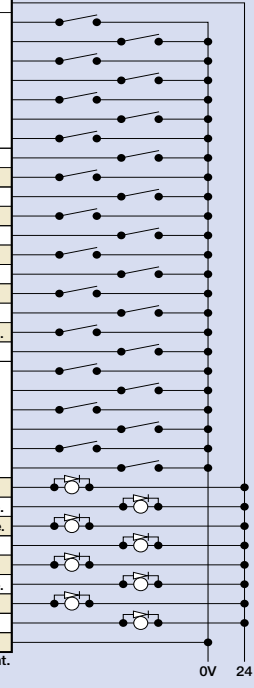

Note: This is for NPN. PNP will be different.

581 SSEL

- Slider Type
- Mini
- Standard
- Controllers Integrated
- Rod Type
- Mini
- Standard
- Controllers Integrated
- Table/Arm /Flat Type
- Mini
- Standard
- Gripper/ Rotary Type
- Linear Servo Type
- Cleanroom Type
- Splash-Proof
- Controllers
- PMEC /AMEC
- PSEP /ASEP
- ROBO NET
- ERC2
- PCON
- ACON
- SDON
- PSEL
- ASEL
- SSEL
- XSEL
- Pulse Motor
- Servo Motor (24V)
- Servo Motor (200V)
- Linear Servo Motor

Explanation of I/O Signal Functions

Positioner, Teaching Mode

Pin Number	Category	Port No.	Positioner Teaching Mode	Functions	
1A	P24		24V input	Connect 24V.	
1B		016	JOG- on 1st axis	While the signal is input, the 1st axis is moved in the - (negative) direction.	
2A		017	JOG+ on 2nd axis	While the signal is input, the 2nd axis is moved in the + (positive) direction.	
2B		018	JOG- on 2nd axis	While the signal is input, the 2nd axis is moved in the - (negative) direction.	
3A		019	Specify inching (0.01mm)	Specifies how much to move during inching. (Total of the values specified for ports 019 to 022)	
3B		020			
4A		021			
4B		022			
5A		023	Error reset	Resets minor errors. (Severe errors require a restart.)	
5B		000	Start	Starts moving to selected position.	
6A		001	Servo ON	Switches between Servo ON and OFF.	
6B		002	Pause	Pauses the motion when turned OFF, and resumes motion when turned ON.	
7A		Input	003	Position input 1	Ports 003 to 013 are used to specify the position number to move, and the position number for inputting the current position. When the teaching mode setting on port 014 is in the ON state, the current value is written to the specified position number.
7B			004	Position input 2	
8A			005	Position input 3	
8B			006	Position input 4	
9A			007	Position input 5	
9B	008		Position input 6		
10A	009		Position input 7		
10B	010		Position input 8		
11A	011		Position input 9		
11B	012		Position input 10		
12A	013		Position input 11		
12B	014	Teaching mode setting			
13A	015	JOG+ on 1st axis	While the signal is input, the 1st axis is moved in the plus direction.		
13B	300	Alarm	Turns off when an alarm occurs. (Contact B)		
14A	301	Ready	Turns on when the controller starts up normally and is in an operable state.		
14B	302	Positioning complete	Turns on when the movement to the destination is complete.		
15A	Output	303	Home Return complete	Turns on when the home return operation is complete.	
15B		304	Servo ON output	Turns on when servo is ON.	
16A		305	-	-	
16B		306	System battery error	Turns on when the system battery runs low (warning level).	
17A		307	Absolute encoder battery error	Turns on when the battery for the absolute encoder runs low (warning level).	
17B		N	0V input	Connect 0V.	

Wiring Diagram

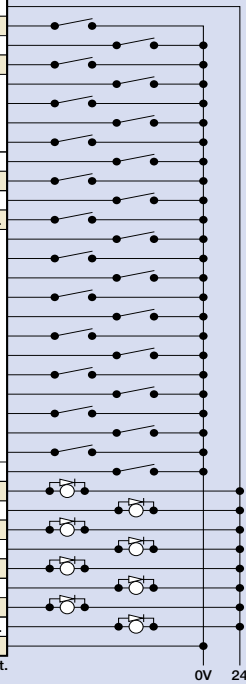

Note: This is for NPN. PNP will be different.

Positioner, DS-S-C1 Compatible Mode

Pin Number	Category	Port No.	Positioner DS-S-C1 Compatible Mode	Functions	
1A	P24		24V input	Connect 24V.	
1B		016	Position No. 1000	(Same as ports 004 through 015)	
2A		017	Position No. 2000	-	
2B		018	Position No. 4000	-	
3A		019	Position No. 8000	-	
3B		020	Position No. 10000	-	
4A		021	Position No. 20000	-	
4B		022	NC (*1)	-	
5A		023	CPU reset	Resets the system to the same state as when the power is turned on.	
5B		000	Start	Starts moving to selected position.	
6A		001	Hold (Pause)	Pauses the motion when turned ON, and resumes motion when turned OFF.	
6B		002	Cancel	Stops the motion when turned ON. The remaining motion is canceled.	
7A		Input	003	Interpolation setting	Ports 004 through 016 are used to specify the position number to move. The numbers are specified as BCD.
7B			004	Position No. 1	
8A			005	Position No. 2	
8B			006	Position No. 4	
9A			007	Position No. 8	
9B	008		Position No. 10		
10A	009		Position No. 20		
10B	010		Position No. 40		
11A	011		Position No. 80		
11B	012		Position No. 100		
12A	013		Position No. 200		
12B	014	Position No. 400			
13A	015	Position No. 800			
13B	300	Alarm	Turns off when an alarm occurs. (Contact A)		
14A	301	Ready	Turns on when the controller starts up normally and is in an operable state.		
14B	302	Positioning complete	Turns on when the movement to the destination is complete.		
15A	Output	303	-	-	
15B		304	-	-	
16A		305	-	-	
16B		306	System battery error	Turns on when the system battery runs low (warning level).	
17A		307	Absolute encoder battery error	Turns on when the battery for the absolute encoder runs low (warning level).	
17B		N	0V input	Connect 0V.	

Wiring Diagram

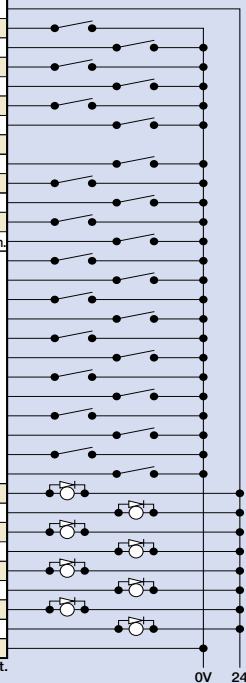

Note: This is for NPN. PNP will be different.

(*1) The input needs to be set to OFF. Be sure to leave this disconnected.

- Slider Type
- Mini
- Standard
- Controllers Integrated
- Rod Type
- Mini
- Standard
- Controllers Integrated
- Table/Arm /Flat Type
- Mini
- Standard
- Gripper/ Rotary Type
- Linear Servo Type
- Cleanroom Type
- Splash-Proof
- Controllers
- PMEC /AMEC
- PSEP /ASEP
- ROBO NET
- ERC2
- PCON
- ACON
- SCON
- PSEL
- ASEL
- SSEL
- XSEL
- Pulse Motor
- Servo Motor (24V)
- Servo Motor (200V)
- Linear Servo Motor

Table of specifications

	Item	Specifications
Basic Specifications	Connected actuator	RCS2 series actuator / single axis robot / linear servo actuator
	Input Voltage	Single-phase AC90V to AC126.5V Single-phase AC180V to AC253V
	Power Supply Capacity	Max. 1660VA (for 400W, 2-axis operation)
	Dielectric strength voltage	DC500V 10MΩ or higher
	Withstand voltage	AC500V 1 min.
	Rush current	Control Power 15A / Motor Power 37.5A Control Power 30A / Motor Power 75A
	Vibration resistance	XYZ directions 10 to 57Hz, One side amplitude: 0.035mm (continuous), 0.075mm (intermittent) 58 to 150 Hz 4.9 m/s ² (continuous), 9.8 m/s ² (intermittent)
Control specification	Number of control axes	1 axis / 2 axis
	Maximum total output of connected axis	400W 800W
	Position detection method	Incremental encoder / Absolute encoder
	Speed setting	1mm/sec and up, the maximum depends on actuator specifications
	Acceleration setting	0.01G and up, the maximum depends on the actuator
	Operating method	Program operation / Positioner operation (switchable)
Program	Programming language	Super SEL language
	Number of programs	128 programs
	Number of program steps	9999 steps
	Number of multi-tasking programs	8 programs
	Positioning Points	20000 points
	Data memory device	FLASHROM (A system-memory backup battery can be added as an option)
Communication	Data input method	Teaching pendant or PC software
	Number of I/O	24 input points / 8 output points (NPN or PNP selectable)
	I/O power	Externally supplied 24VDC ± 10%
	PIO cable	CB-DS-PIO □□□ (supplied with the controller)
	Serial communications function	RS232C (D-Sub Half-pitch connector) / USB connector
	Field Network	DeviceNet, CC-Link, ProfiBus
	Motor Cable	CB-ACS-MA □□□ (Max. 20m)
Encoder cable	CB-RCP2-PA □□□ (Max. 20m)	
General specifications	Protection function	Motor overcurrent, Motor driver temperature check, Overload check, Encoder open-circuit check Soft limit over, system error, battery error, etc.
	Ambient operating humidity and temperature	0 to 40°C 10 to 95% (non-condensing)
	Ambient atmosphere	Free from corrosive gases. In particular, there shall be no significant dust.
	Protection class	IP20
	Weight	1.4kg
	External dimensions	100mm (W) x 202.6mm (H) x 126mm (D)

External Dimensions

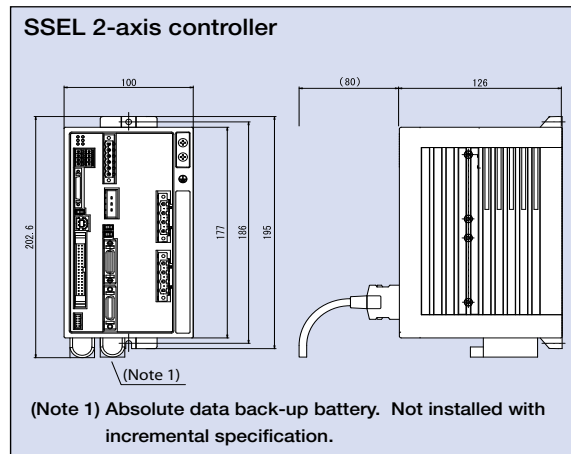
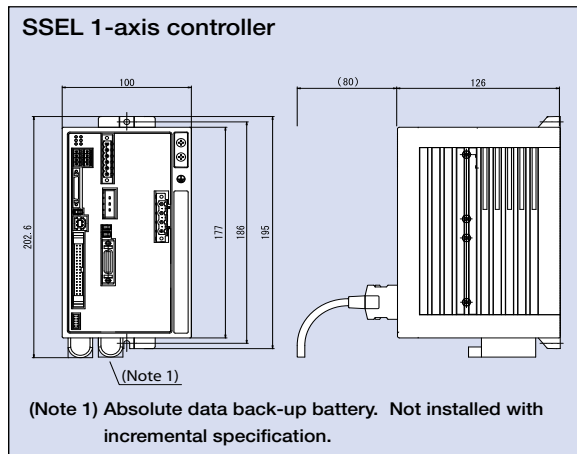

583

SSEL

- Slider Type
- Mini
- Standard
- Controllers Integrated
- Rod Type
- Mini
- Standard
- Controllers Integrated
- Table/Arm /Flat Type
- Mini
- Standard
- Gripper/ Rotary Type
- Linear Servo Type
- Cleanroom Type
- Splash-Proof
- Controllers
- PMEC /AMEC
- PSEP /ASEP
- ROBO NET
- ERC2
- PCON
- ACON
- SCON
- PSEL
- ASEL
- SSEL
- XSEL
- Pulse Motor
- Servo Motor (24V)
- Servo Motor (200V)
- Linear Servo Motor

Name of Each Part

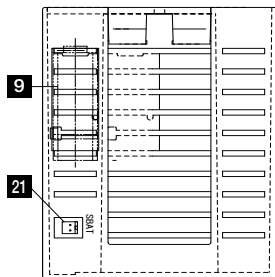
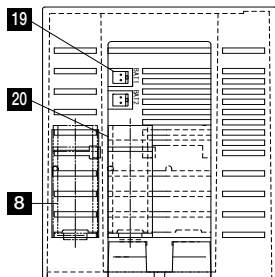
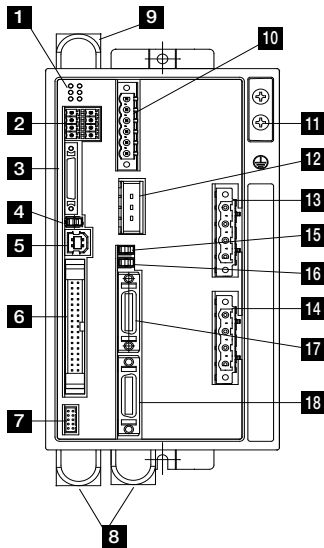

1 Status indicator LEDs

These LEDs are used to indicate the operating condition of the controller.

The LED status indicators are as follows:

- PWR : Power is input to controller.
- RDY : The controller is ready to perform program operation.
- ALM : The controller is abnormal.
- EMG : An emergency stop is actuated and the drive source is cut off.
- SV1 : The axis 1 actuator servo is on.
- SV2 : The axis 2 actuator servo is on.

2 System I/O connector

Connector for emergency stop / enable input / brake power input, etc.

3 Teaching pendant connector

A half-pitch I/O 26-pin connector that connects a teaching pendant when the running mode is MANU. A special conversion cable is needed to connect a conventional Dsub, 25-pin connector.

4 Mode switch

This switch is used to specify the running mode of the controller. The left position indicates the MANU (manual operation) mode, while the right position indicates the AUTO (automatic operation) mode. Teaching can only be performed as manual operation, and automatic operation using external I/Os is not possible in the MANU mode.

5 USB connector

A connector for PC connection via USB. If the USB connector is connected, the TP connector is disabled and all communication inputs to the TP connector are cut off.

6 I/O Connector

A connector for interface I/Os.

34-pin flat cable connector for DIO (24IN/8OUT) interface.

I/O power is also supplied to the controller via this connector (Pin No. 1 and No. 34).

7 Panel unit connector

A connector for the panel unit (optional) that displays the controller status and error numbers.

8 Absolute data backup battery

When an absolute-type axis is operated, this battery retains position data even after the power is cut off.

9 System memory backup battery (Option)

This battery is needed if you wish to retain various data recorded in the SRAM of the controller even after the power is cut off.

This battery is optional. Specify it if necessary.

10 Power supply connector

AC power connector. Divided into the control power input and motor power input.

11 Grounding screw

Protective grounding screw. Always ground this screw.

12 External regenerative resistor connector

A connector for the regenerative resistor that must be connected when the built-in regenerative resistor alone does not offer sufficient capacity in high-acceleration/high-load operation, etc.

Whether or not an external regenerative resistor is necessary depends on the conditions of your specific application such as the axis configuration.

13 Motor connector for axis 1

Connects the motor cable of the axis 1 actuator.

14 Motor connector for axis 2

Connects the motor cable of the axis 2 actuator.

15 Brake switch for axis 1

This switch is used to release the axis brake. Setting it to the left position (RLS side) forcibly releases the brake, while setting it to the right position (NOM side) causes the controller to automatically control the brake.

16 Brake switch for axis 2

This switch is used to release the axis brake. Setting it to the left position (RLS side) forcibly releases the brake, while setting it to the right position (NOM side) causes the controller to automatically control the brake.

17 Encoder connector for axis 1

Connect the encoder cable of the axis 1 actuator.

18 Encoder connector for axis 2

Connect the encoder cable of the axis 2 actuator.

19 Absolute-data backup battery connector for axis 1

A connector for the battery that backs up absolute data for axis 1 when the actuator uses an absolute encoder.

20 Absolute-data backup battery connector for axis 2

A connector for the battery that backs up absolute data for axis 2 when the actuator uses an absolute encoder.

21 System-memory backup battery connector

A connector for the system-memory backup battery.

- Slider Type
- Mini
- Standard
- Controllers Integrated
- Rod Type
- Mini
- Standard
- Controllers Integrated
- Table/Arm /Flat Type
- Mini
- Standard
- Cripper/ Rotary Type
- Linear Servo Type
- Cleanroom Type
- Splash-Proof
- Controllers
- PMEC /AMEC
- PSEP /ASEP
- ROBO NET
- ERC2
- PCON
- ACON
- SCON
- PSEL
- ASEL
- SSEL
- XSEL
- Pulse Motor
- Servo Motor (24V)
- Servo Motor (200V)
- Linear Servo Motor

Option

Teaching Pendant

Features A teaching device for entering programs and positions, test runs, and monitoring.

Model/Price

Model	Description
SEL-T-J	Standard type with adapter cable
SEL-TD-J	Deadman's switch type and adapter cable

Configuration

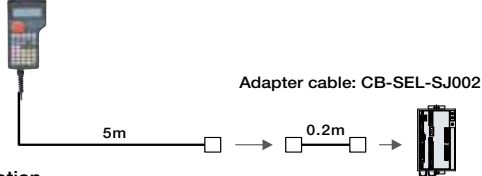

SEL-T option

- Wall-mounting hook Model HK-1

- Strap Model STR-1

Specifications

Item	SEL-T-J	SEL-TD-J
3-position Enable Switch	No	Yes
ANSI/UL standards	Non-compliant	Compliant
CE mark	Compliant	
Display	20 char. x 4 lines	
Ambient Operating Temp./Humidity	0~40°C 10~90% RH (non-condensing)	
Protective structure	IP54	
Weight	Approx. 0.4kg (not incl. cable)	

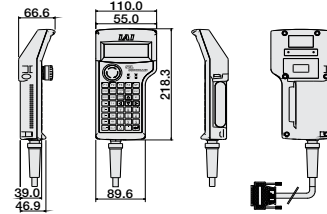

PC Software (Windows Only)

Features A startup support software for entering programs/positions, performing test runs, and monitoring. More functions have been added for debugging, and improvements have been made to shorten the start-up time.

Model IA-101-X-MW-J (with RS232C cable + adapter cable)
IA-101-X-MW (with RS232C cable)

Configuration

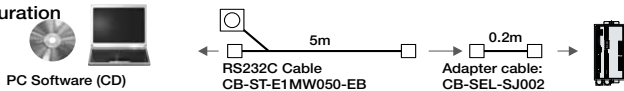

Model IA-101-X-USB (with USB cable)

Configuration

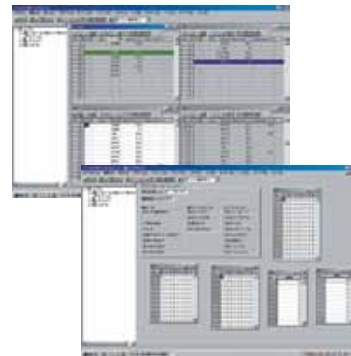
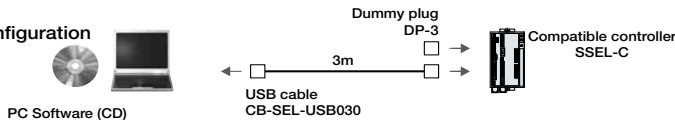

Note:
Only versions 6.0.0.0 and later can be used with the SSEL controller.

Regenerative Resistor Unit

Features A unit that converts the regenerative current, generated during the acceleration/deceleration of the motor, into heat. In the table on the right, check the total power output of the actuator to see if a regenerative resistor is needed.

Model REU-2 (for SCON/SSEL) Standard Price

Specifications

Weight of main unit	0.9kg
Internal regenerative resistance	220Ω 80W
Main unit-Controller	
Connection Cable (included)	CB-SC-REU010 (for SSEL)

* If 2 regenerative units are needed, acquire one REU-2 and one REU-1 (See P596).

Required Number of Units

	Horizontal	Vertical
0 units	~200W	~200W
1 unit	~800W	~600W
2 units	~800W	~800W

* Depending on the operating conditions, more regenerative resistors may be needed.

Exterior Dimensions

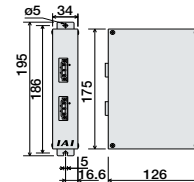

Panel Unit

Features Display device that shows the error code from the controller or the currently running program number.

Model PU-1 (Cable length: 3m)

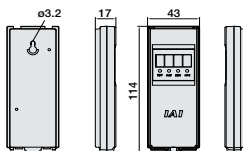

Absolute Data Backup Battery

Features Battery for saving absolute data, when operating an actuator with an absolute encoder. Same as the battery used for system memory backup.

Model AB-5



System Memory Backup Battery

Features This battery is required, for example, when you are using global flags in the program and you want to retain your data even after the power has been turned OFF.

Model AB-5-CS (with case)
AB-5 (Standalone battery)



585

SSEL

- Slider Type
- Mini
- Standard
- Controllers Integrated
- Rod Type
- Mini
- Standard
- Controllers Integrated
- Table/Arm /Flat Type
- Mini
- Standard
- Gripper/ Rotary Type
- Linear Servo Type
- Cleanroom Type
- Splash-Proof
- Controllers
- PMEC /AMEC
- PSEP /ASEP
- ROBO NET
- ERC2
- PCON
- ACON
- SCON
- PSEL
- ASEL
- SSEL
- XSEL
- Pulse Motor
- Servo Motor (24V)
- Servo Motor (200V)
- Linear Servo Motor

Option

Dummy Plug

- Features** When connecting the SSEL controller to a computer with a USB cable, this plug is inserted in the teaching port to shut off the enable circuit.
(Supplied with the PC software IA-101-X-USB)

Model DP-3



USB Cable

- Features** A cable for connecting the controller to the USB port to a computer. A controller with no USB port (e.g. XSEL) can be connected to the USB port of a computer by connecting an RS232C cable to the USB cable via a USB adapter.
(See PC software IA-101-X-USBMW)

Model CB-SEL-USB030 (Cable length: 3m)



Adapter Cable

- Features** An adapter cable to connect the D-sub 25-pin connector from the teaching pendant or a PC to the teaching connector (half-pitch) of the SSEL controller.

Model CB-SEL-SJ002 (Cable length: 0.2m)



Spare parts

When you need spare parts after purchasing the product, such as when replacing a cable, refer to the list of models below.

Motor cable/Motor robot cable

Model CB-RCC-MA / **CB-RCC-MA** **-RB**

* Enter the cable length (L) into . Compatible to a maximum of 30 meters.
Ex.: 080 = 8 m

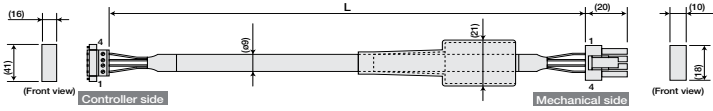

Wire	Color	Signal	No.
Green	PE	1	
Red	U	2	
White	V	3	
Black	W	4	

Signal	Color	Wire
1	U	Red
2	V	White
3	W	Black
4	PE	Green

0.75sq (crimped)

Min. bend radius $r = 50$ mm or larger (when movable type is used)
* Only the robot cable is to be used in a cable track.

Encoder cable/Encoder robot cable

Model CB-RCS2-PA / **CB-X3-PA**

* Enter the cable length (L) into . Compatible to a maximum of 30 meters.
Ex.: 080 = 8 m

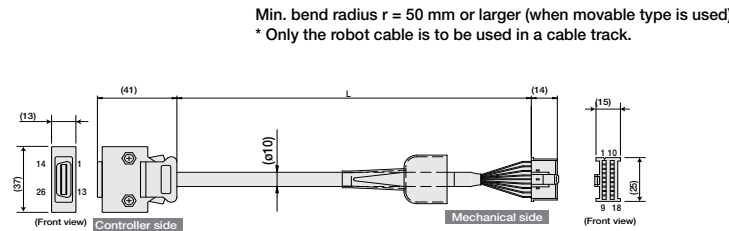

Wire	Color	Signal	No.
Black	PE	1	10
White	U	2	11
Gray/White	EdV	12	12
Brown/White	V	13	13
Brown/Black	W	14	14
Blue	CCP	25	25
Orange	LS	26	26
Brown/White	CCPSP	27	27
Brown/Red	OT	24	24
Brown/Black	RSV	28	28
Green	W	6	9
Black	SRD+	7	15
Orange	SRD-	8	19
Black	BAT+	14	1
Yellow	BAT-	15	2
Green	VCC	16	3
Brown	GND	17	4
Gray	RSV	28	5
Red	BK+	21	6
Blue	BK-	22	7
White	W	3	8
Black	W	4	9
White/Blue	A+	1	10
White/Red	A-	2	11
White/Black	B+	3	12
White/Purple	B-	4	13
White/Gray	Z+	5	14
White/Green	Z-	6	15
Orange	SRD+	7	16
Purple	SRD-	8	17
White/Blue	BAT+	14	18
White/Red	BAT-	15	19
White/Black	VCC	16	20
White/Purple	GND	17	21
White/Gray	RSV	28	22
White/Green	W	6	23
White/Black	W	4	24
White/Blue	W	3	25
White/Red	W	2	26
White/Purple	W	1	27
White/Gray	W	0	28
White/Green	W	-	29
White/Black	W	-	30

The shield is connected to the hood by a clamp.

Min. bend radius $r = 50$ mm or larger (when movable type is used)
* Only the robot cable is to be used in a cable track.

Encoder cable/Encoder robot cable for RCS2-RT6/RT6R/RT7R/RA13R

Model CB-RCS2-PLA / **CB-X2-PLA**

* Enter the cable length (L) into . Compatible to a maximum of 30 meters.
Ex.: 080 = 8 m

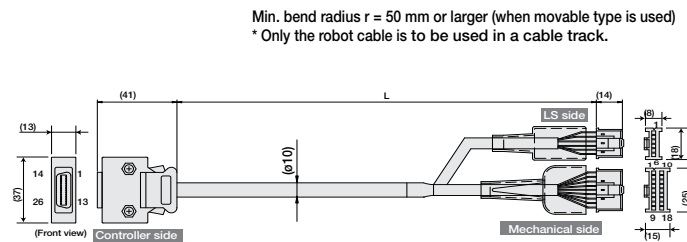

Wire	Color	Signal	No.
Black	PE	1	10
White/Orange	P2V	12	12
White/Gray	W	13	13
Brown/Blue	LS	26	26
Brown/White	CCPSP	27	27
Brown/Red	OT	24	24
Brown/Black	RSV	28	28
Green	W	6	9
Black	SRD+	7	15
Purple	SRD-	8	19
White/Blue	A+	1	1
White/Red	A-	2	2
White/Black	B+	3	3
White/Purple	B-	4	4
White/Gray	Z+	5	5
White/Green	Z-	6	6
Orange	SRD+	7	7
Purple	SRD-	8	8
White/Blue	BAT+	14	14
White/Red	BAT-	15	15
White/Black	VCC	16	16
White/Purple	GND	17	17
White/Gray	RSV	28	28
White/Green	W	6	18
White/Black	W	4	19
White/Blue	W	3	20
White/Red	W	2	21
White/Purple	W	1	22
White/Gray	W	0	23
White/Green	W	-	24
White/Black	W	-	25
White/Blue	W	-	26
White/Red	W	-	27
White/Purple	W	-	28
White/Gray	W	-	29
White/Green	W	-	30
White/Black	W	-	31
White/Blue	W	-	32
White/Red	W	-	33
White/Purple	W	-	34
White/Gray	W	-	35
White/Green	W	-	36
White/Black	W	-	37
White/Blue	W	-	38
White/Red	W	-	39
White/Purple	W	-	40
White/Gray	W	-	41
White/Green	W	-	42
White/Black	W	-	43
White/Blue	W	-	44
White/Red	W	-	45
White/Purple	W	-	46
White/Gray	W	-	47
White/Green	W	-	48
White/Black	W	-	49
White/Blue	W	-	50
White/Red	W	-	51
White/Purple	W	-	52
White/Gray	W	-	53
White/Green	W	-	54
White/Black	W	-	55
White/Blue	W	-	56
White/Red	W	-	57
White/Purple	W	-	58
White/Gray	W	-	59
White/Green	W	-	60
White/Black	W	-	61
White/Blue	W	-	62
White/Red	W	-	63
White/Purple	W	-	64
White/Gray	W	-	65
White/Green	W	-	66
White/Black	W	-	67
White/Blue	W	-	68
White/Red	W	-	69
White/Purple	W	-	70
White/Gray	W	-	71
White/Green	W	-	72
White/Black	W	-	73
White/Blue	W	-	74
White/Red	W	-	75
White/Purple	W	-	76
White/Gray	W	-	77
White/Green	W	-	78
White/Black	W	-	79
White/Blue	W	-	80
White/Red	W	-	81
White/Purple	W	-	82
White/Gray	W	-	83
White/Green	W	-	84
White/Black	W	-	85
White/Blue	W	-	86
White/Red	W	-	87
White/Purple	W	-	88
White/Gray	W	-	89
White/Green	W	-	90
White/Black	W	-	91
White/Blue	W	-	92
White/Red	W	-	93
White/Purple	W	-	94
White/Gray	W	-	95
White/Green	W	-	96
White/Black	W	-	97
White/Blue	W	-	98
White/Red	W	-	99
White/Purple	W	-	100
White/Gray	W	-	101
White/Green	W	-	102
White/Black	W	-	103
White/Blue	W	-	104
White/Red	W	-	105
White/Purple	W	-	106
White/Gray	W	-	107
White/Green	W	-	108
White/Black	W	-	109
White/Blue	W	-	110
White/Red	W	-	111
White/Purple	W	-	112
White/Gray	W	-	113
White/Green	W	-	114
White/Black	W	-	115
White/Blue	W	-	116
White/Red	W	-	117
White/Purple	W	-	118
White/Gray	W	-	119
White/Green	W	-	120
White/Black	W	-	121
White/Blue	W	-	122
White/Red	W	-	123
White/Purple	W	-	124
White/Gray	W	-	125
White/Green	W	-	126
White/Black	W	-	127
White/Blue	W	-	128
White/Red	W	-	129
White/Purple	W	-	130
White/Gray	W	-	131
White/Green	W	-	132
White/Black	W	-	133
White/Blue	W	-	134
White/Red	W	-	135
White/Purple	W	-	136
White/Gray	W	-	137
White/Green	W	-	138
White/Black	W	-	139
White/Blue	W	-	140
White/Red	W	-	141
White/Purple	W	-	142
White/Gray	W	-	143
White/Green	W	-	144
White/Black	W	-	145
White/Blue	W	-	146
White/Red	W	-	147
White/Purple	W	-	148
White/Gray	W	-	149
White/Green	W	-	150
White/Black	W	-	151
White/Blue	W	-	152
White/Red	W	-	153
White/Purple	W	-	154
White/Gray	W	-	155
White/Green	W	-	156
White/Black	W	-	157
White/Blue	W	-	158
White/Red	W	-	159
White/Purple	W	-	160
White/Gray	W	-	161
White/Green	W	-	162
White/Black	W	-	163
White/Blue	W	-	164
White/Red	W	-	165
White/Purple	W	-	166
White/Gray	W	-	167
White/Green	W	-	168
White/Black	W	-	169
White/Blue	W	-	170
White/Red	W	-	171
White/Purple	W	-	172
White/Gray	W	-	173
White/Green	W	-	174
White/Black	W	-	175
White/Blue	W	-	176
White/Red	W	-	177
White/Purple	W	-	178
White/Gray	W	-	179
White/Green	W	-	180
White/Black	W	-	181
White/Blue	W	-	182
White/Red	W	-	183
White/Purple	W	-	184
White/Gray	W	-	185
White/Green	W	-	186
White/Black	W	-	187
White/Blue	W	-	188
White/Red	W	-	189
White/Purple	W	-	190
White/Gray	W	-	191
White/Green	W	-	192
White/Black	W	-	193
White/Blue	W	-	194
White/Red	W	-	195
White/Purple	W	-	196
White/Gray	W	-	197
White/Green	W	-	198
White/Black	W	-	199
White/Blue	W	-	200

The shield is connected to the hood by a clamp.

Min. bend radius $r = 50$ mm or larger (when movable type is used)
* Only the robot cable is to be used in a cable track.

I/O Flat Cable

Model CB-DS-PIO

* Enter the cable length (L) into . Compatible to a maximum of 10 meters.
Ex.: 080 = 8 m

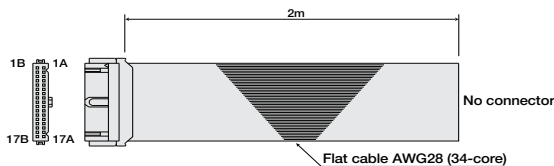

Pin No.	Color	Wire	Pin No.	Color	Wire
1A	Brown 1		9B	Gray 2	
1B	Red 1		10A	White 2	
2A	Orange 1		10B	Black 2	
2B	Yellow 1		11A	Brown-3	
3A	Green 1		11B	Red 3	
3B	Blue 1		12A	Orange 3	
4A	Purple 1		12B	Yellow 3	
4B	Gray 1		13A	Green 3	
5A	White 1		13B	Blue 3	
5B	Black 1		14A	Purple 3	
6A	Brown-2		14B	Gray 3	
6B	Red 2		15A	White 3	
7A	Orange 2		15B	Black 3	
7B	Yellow 2		16A	Brown-4	
8A	Green 2		16B	Red 4	
8B	Blue 2		17A	Orange 4	
9A	Purple 2		17B	Yellow 4	

- Slider Type
- Mini
- Standard
- Controllers Integrated
- Rod Type
- Mini
- Standard
- Controllers Integrated

X-SEL

Program controller
For RCS2 series







- Table/Arm /FlatType
- Mini
- Standard
- Gripper/ Rotary Type
- Linear Servo Type
- Cleanroom Type
- Splash-Proof

- Controllers
- PMEC /AMEC
- PSEP /ASEP
- ROBO NET
- ERC2
- PCON
- ACON
- SCON
- PSEL
- ASEL
- SSEL
- XSEL

List of models

Multiaxial program controller for operating RCS2 Series actuators. Up to 6 axes can be simultaneously controlled.

Type	J	K	P	Q
Name	Compact Type	General Purpose Type	Large-Capacity Type	Large-Capacity Type (Safety Category Compliant)
External View				
Description	Compact, low-cost type ideal for operating low-output actuators	Standard type offering excellent expandability	Large-capacity type capable of controlling up to six axes or 2,400W	Large-capacity type conforming to safety category 4
Maximum number of control axes	4-axis		6-axis	
Number of positions	3,000 positions		20,000 positions	
Total Number of Connectable W	800W	1600W	2400W	
Power Supply	Single-phase AC100V/Single-phase AC200V		Single-phase AC200V/3-phase AC200V	
Safety Category	B		B	Category 4 compatible
Safety Rating	-	-	CE	CE, ANSI

(*1) The maximum output for 1 shaft during vertical operation is limited to 600W.

(*2) Axis 5 and axis 6 cannot control the RCS2-RA7/SRA7 series.

- Pulse Motor
- Servo Motor (24V)
- Servo Motor (200V)
- Linear Servo Motor

587 XSEL

System configuration

J (small) / K (general) / KE (CE type)

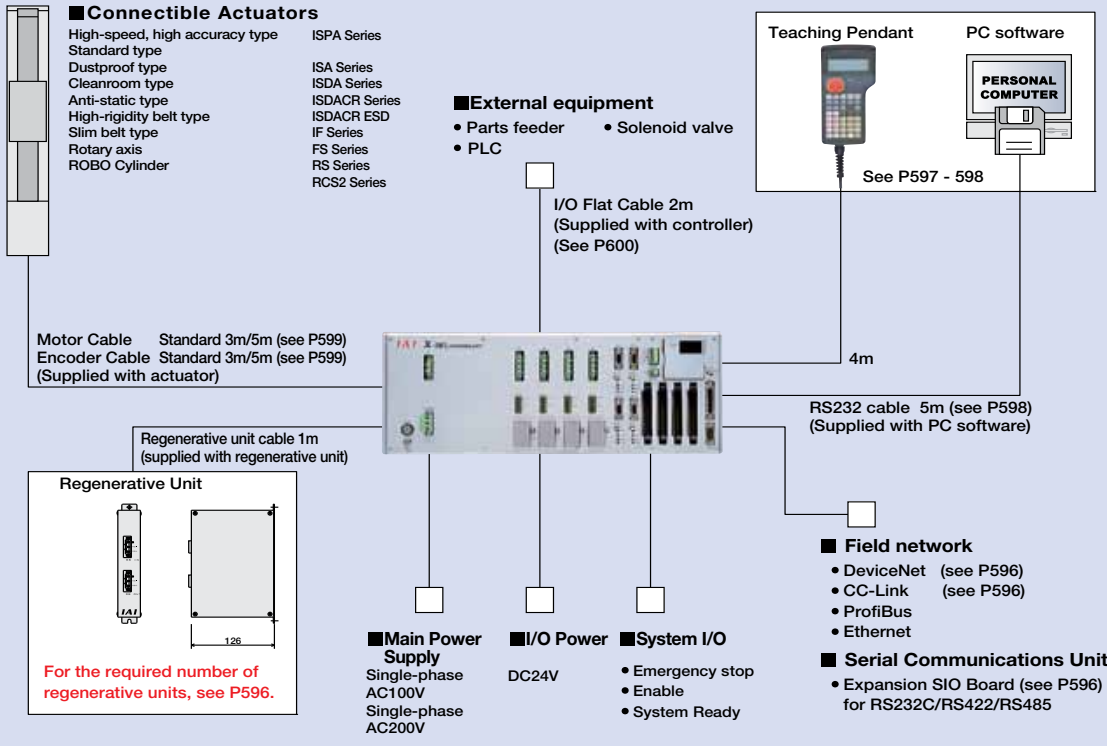

P (high-capacity type) / Q (high-capacity global type)

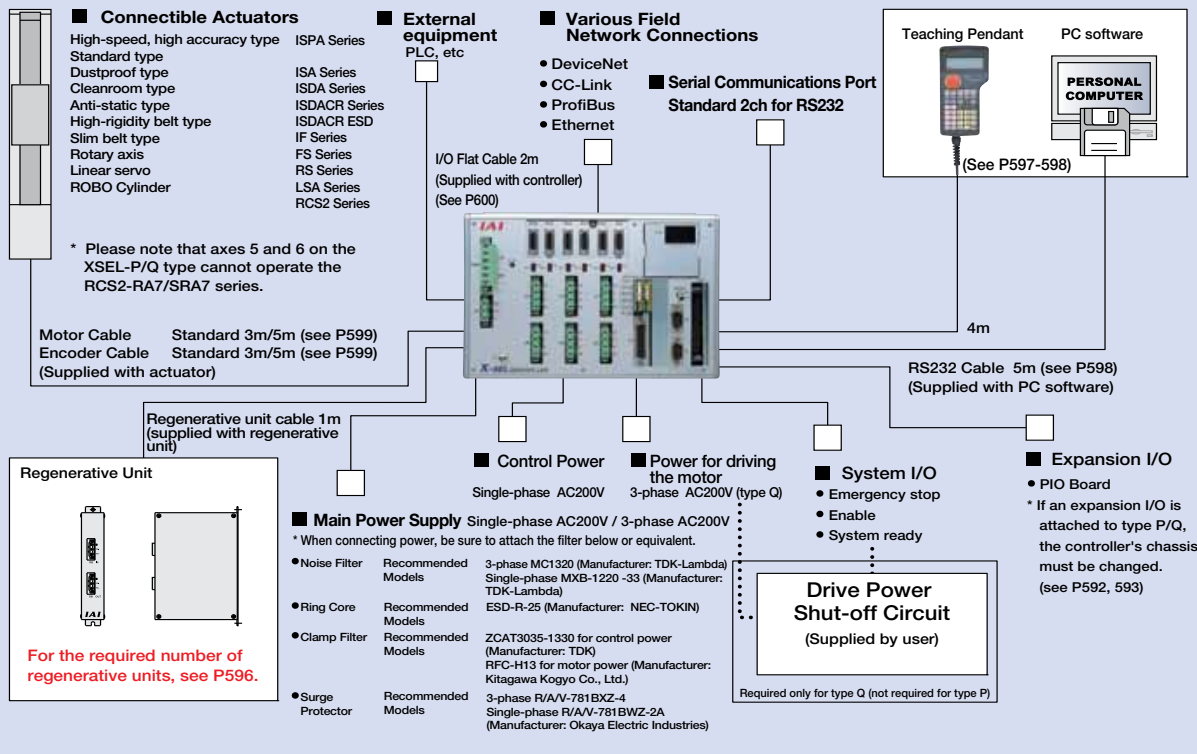

589 XSEL

Sold & Serviced By:

ELECTROMATE
Toll Free Phone (877) SERV098
Toll Free Fax (877) SERV099
www.electromate.com
sales@electromate.com

- Slider Type
- Mini
- Standard
- Controllers Integrated
- Rod Type
- Mini
- Standard
- Controllers Integrated
- Table/Arm /FlatType
- Mini
- Standard
- Gripper/ Rotary Type
- Linear Servo Type
- Cleanroom Type
- Splash-Proof
- Controllers
- PMEC /AMEC
- PSEP /ASEP
- ROBO NET
- ERC2
- PCON
- ACON
- SCON
- PSEL
- ASEL
- SSEL
- XSEL
- Pulse Motor
- Servo Motor (24V)
- Servo Motor (200V)
- Linear Servo Motor

I/O wiring drawing

Input section External input specification (NPN specification)

Item	Specifications
Input voltage	DC24V ±10%
Input current	7mA / circuit
ON/OFF voltage	ON Voltage... Min DC16.0V / OFF Voltage... Max DC5.0V
Isolation method	Photocoupler
Externally Connected Equipment	(1) Non-Voltage Contact (Minimum load around DC5V, 1mA) (2) Photoelectric Proximity Sensor (NPN Type) (3) PLC Transistor Output (Open Collector Type) (4) PLC Contact Output (Minimum Load approx. DC5V, 1mA)

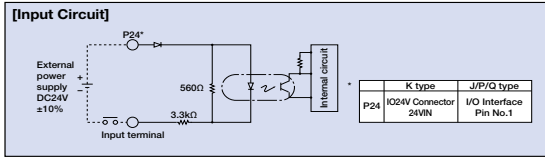

Input section External input specification (PNP specification)

Item	Specifications
Input voltage	DC24V ±10%
Input current	7mA / circuit
ON/OFF voltage	ON Voltage... Min DC8V / OFF Voltage... Max DC19V
Isolation method	Photocoupler
Externally Connected Equipment	(1) Non-Voltage Contact (Minimum load around DC5V, 1mA) (2) Photoelectric Proximity Sensor (PNP Type) (3) PLC Transistor Output (Open Collector Type) (4) PLC Contact Output (Minimum Load approx. DC5V, 1mA)

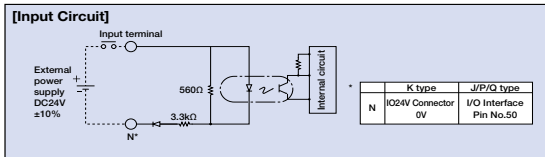

Output section External input specification (NPN specification)

Item	Specifications
Load Voltage	DC24V
Max. load current	100mA / point 400 mA
Leak current	Peak (Total Current)
Isolation method	Max 0.1mA / point
Externally Connected Equipment	Photocoupler
Equipment	(1) Miniature Relay, (2) PLC Input Unit

TD62084 (or equivalent)

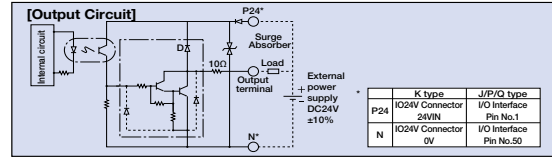

Output section External input specification (PNP specification)

Item	Specifications
Load Voltage	DC24V
Max. load current	100mA / 1 point 400mA / 8 port (Note)
Leak current	Max 0.1mA / point
Isolation method	Photocoupler
Externally Connected Equipment	(1) Miniature Relay, (2) PLC Input Unit

TD62784 (or equivalent)

(Note) 400mA is the maximum total load current for each set of the eight ports from output port No. 300. (The maximum total current output for output port No. 300+n to No. 300+n+7 must be 400mA, where n = 0 or a multiple of eight.)

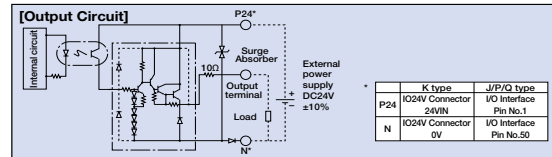

I/O Signal table

Standard I/O Signal Table (when N1 or P1 is selected)

Pin No.	Classification	Port No.	Standard Settings
1		—	(J/P/Q type: 24V connection / K type: NC)
2		000	Program start
3		001	General Purpose Input
4		002	General Purpose Input
5		003	General Purpose Input
6		004	General Purpose Input
7		005	General Purpose Input
8		006	General Purpose Input
9		007	Program Specification (PRG No. 1)
10		008	Program Specification (PRG No. 2)
11		009	Program Specification (PRG No. 4)
12		010	Program Specification (PRG No. 8)
13		011	Program Specification (PRG No. 10)
14		012	Program Specification (PRG No. 20)
15		013	Program Specification (PRG No. 40)
16	Input	014	General Purpose Input
17		015	General Purpose Input
18		016	General Purpose Input
19		017	General Purpose Input
20		018	General Purpose Input
21		019	General Purpose Input
22		020	General Purpose Input
23		021	General Purpose Input
24		022	General Purpose Input
25		023	General Purpose Input
26		024	General Purpose Input
27		025	General Purpose Input
28		026	General Purpose Input
29		027	General Purpose Input
30	028	General Purpose Input	
31	029	General Purpose Input	
32	030	General Purpose Input	
33	031	General Purpose Input	
34	300	Alarm Output	
35	301	Ready Output	
36	302	Emergency Stop Output	
37	303	General Purpose Output	
38	304	General Purpose Output	
39	305	General Purpose Output	
40	306	General Purpose Output	
41	307	General Purpose Output	
42	308	General Purpose Output	
43	309	General Purpose Output	
44	310	General Purpose Output	
45	311	General Purpose Output	
46	312	General Purpose Output	
47	313	General Purpose Output	
48	314	General Purpose Output	
49	315	General Purpose Output	
50		—	(J/P/Q type: 0V connection/K type: NC)

Extension I/O Signal Table (when N1 or P1 is selected)

Pin No.	Classification	Standard Settings
1		(J/P/Q type: 24V connection / K type: NC)
2		General Purpose Input
3		General Purpose Input
4		General Purpose Input
5		General Purpose Input
6		General Purpose Input
7		General Purpose Input
8		General Purpose Input
9		General Purpose Input
10		General Purpose Input
11		General Purpose Input
12		General Purpose Input
13		General Purpose Input
14		General Purpose Input
15		General Purpose Input
16		General Purpose Input
17	Input	General Purpose Input
18		General Purpose Input
19		General Purpose Input
20		General Purpose Input
21		General Purpose Input
22		General Purpose Input
23		General Purpose Input
24		General Purpose Input
25		General Purpose Input
26		General Purpose Input
27		General Purpose Input
28		General Purpose Input
29		General Purpose Input
30		General Purpose Input
31	General Purpose Input	
32	General Purpose Input	
33	General Purpose Input	
34	General Purpose Output	
35	General Purpose Output	
36	General Purpose Output	
37	General Purpose Output	
38	General Purpose Output	
39	General Purpose Output	
40	General Purpose Output	
41	General Purpose Output	
42	General Purpose Output	
43	General Purpose Output	
44	General Purpose Output	
45	General Purpose Output	
46	General Purpose Output	
47	General Purpose Output	
48	General Purpose Output	
49	General Purpose Output	
50		(J/P/Q type: 0V connection/K type: NC)

Extension I/O Signal Table (when N2 or P2 is selected)

Pin No.	Classification	Standard Settings
1		(J/P/Q type: 24V connection / K type: NC)
2		General Purpose Input
3		General Purpose Input
4		General Purpose Input
5		General Purpose Input
6		General Purpose Input
7		General Purpose Input
8		General Purpose Input
9	Input	General Purpose Input
10		General Purpose Input
11		General Purpose Input
12		General Purpose Input
13		General Purpose Input
14		General Purpose Input
15		General Purpose Input
16		General Purpose Input
17		General Purpose Input
18		General Purpose Output
19		General Purpose Output
20		General Purpose Output
21		General Purpose Output
22		General Purpose Output
23	General Purpose Output	
24	General Purpose Output	
25	General Purpose Output	
26	General Purpose Output	
27	General Purpose Output	
28	General Purpose Output	
29	General Purpose Output	
30	General Purpose Output	
31	General Purpose Output	
32	General Purpose Output	
33	General Purpose Output	
34	Output	General Purpose Output
35		General Purpose Output
36		General Purpose Output
37		General Purpose Output
38		General Purpose Output
39		General Purpose Output
40		General Purpose Output
41		General Purpose Output
42		General Purpose Output
43		General Purpose Output
44		General Purpose Output
45		General Purpose Output
46		General Purpose Output
47		General Purpose Output
48		General Purpose Output
49		General Purpose Output
50		

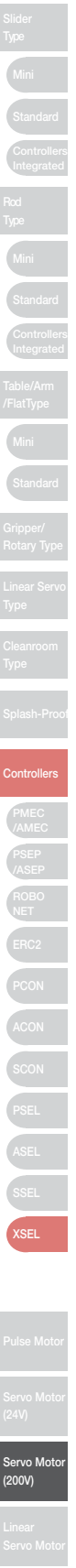

Table of specifications

J (Compact) / K (General Purpose)

Item	Description												
	J (Compact) Type						K (General Purpose) Type / KE (CE Compatible) Type						
Controller Series, Type	J (Compact) Type / K (General Purpose) Type / KE (CE Compatible) Type												
Connecting actuator	RCS2 / ISA / ISPA / ISP / ISDA / ISDACR / ISPDACR / IF / FS / RS												
Compatible Motor Output (W)	20 / 30 / 60 / 100 / 150 / 200 / 300 / 400 / 600 / 750												
Number of control axes	1-axis	2-axis	3-axis	4-axis	1-axis	2-axis	3-axis	4-axis					
Maximum Connected Axes Output (W)	Max. 800 (When power supply voltage is 200V) Max. 400 (When power supply voltage is 100V)						800	Max. 1600 (When power supply voltage is 200V) Max. 800 (When power supply voltage is 100V)					
Input Voltage	100V Specification: Single-phase AC100 to 115V 200V Specification: Single-phase AC200 to 230V												
Motor Power Input	±10%												
Power Supply Frequency	50Hz/60Hz												
Power Supply Capacity	Max 1670VA	Max 1720VA	Max 1810VA	Max 1670VA	Max 3120VA	Max 3220VA	Max 3310VA						
Position detection method	Incremental Encoder (Serial encoder) Absolute encoder with a rotational data backup (Serial encoder)												
Speed setting	1mm/sec and up, the maximum depends on actuator specifications												
Acceleration setting	0.01G and up, the maximum depends on the actuator												
Programming language	Super SEL language												
Number of programs	64 Programs												
Number of program steps	6,000 Steps (total)												
Number of multi-tasking programs	16 Programs												
Number of Positions	3,000 positions												
Data memory device	FLASH ROM+SRAM Battery Backup												
Data input method	Teaching pendant or PC software												
Standard Input/Output	32 points (total of dedicated inputs + general-purpose inputs) / 16 points (total of dedicated outputs + general-purpose outputs)												
Expansion Input/Output	None	48 points per unit (1 more unit can be installed)						48 points per unit (3 more units can be installed)					
Serial communications function	Teaching Port (25-pin D-sub) Standard Equipment						Teaching Pendant+ Expansion SIO Board Installable (optional)						
Other Input/Output	System I/O (Emergency Stop Input, Enable Input, System Ready Output)												
Protection function	Motor overcurrent, Motor driver temperature check, Overload check, Encoder open-circuit check soft limit over, system error, battery error, etc.												
Ambient Operating Temp./Humidity	Temperature 0 to 40°C, Humidity 30 to 85%												
Ambient atmosphere	Free from corrosive gases. In particular, there shall be no significant dust.												
Weight	2.6kg	3.3kg	5.0kg	6.0kg	7.0kg								
Accessory	I/O Flat Cable												

P (Large-Capacity Standard Type) / Q (Large-Capacity Global Type)

Item	Description												
	P (Standard) Type						Q (Global) Type						
Controller Series, Type	P (Standard) Type / Q (Global) Type												
Connecting actuator	RCS2 / ISA / ISPA / ISP / ISDA / ISDACR / ISPDACR / IF / FS / RS / LSA												
Compatible Motor Output	20 / 30 / 60 / 100 / 150 / 200 / 300 / 400 / 600 / 750												
Number of Controlled Axes	1-axis	2-axis	3-axis	4-axis	5-axis	6-axis	1-axis	2-axis	3-axis	4-axis	5-axis	6-axis	
Maximum Connected Axes Output (W)	Max 2400W (The single-phase AC200V specification is 1600W)												
Control Power Input	Single-phase AC170V to AC253V						Single-phase AC170V to AC253V						
Motor Power Input	Single-phase/3-phase AC180V to AC253V						Single-phase/3-phase AC180V to AC253V						
Power Supply Frequency	50 / 60Hz												
Insulation Resistance	10MΩ or more (between the power-supply terminal and I/O terminals, and between all external terminals and case, at 500VDC)												
Withstand Voltage	AC1500V (1 minute)						AC1500V (1 minute)						
Power Supply Capacity (*1)	Max 1744VA	Max 3266VA	Max 4787VA	Max 4878VA	Max 4931VA	Max 4998VA	Max 1744VA	Max 3266VA	Max 4787VA	Max 4878VA	Max 4931VA	Max 4998VA	
Position detection method	Incremental Encoder (Serial encoder) Absolute encoder with a rotational data backup (Serial encoder)												
Safety Circuit Configuration	Redundancy not supported						Double Redundant Enabled						
Drive Source Breaker System	Internal cutoff relay						External Safety Circuit						
Enable Input	B Contact Input (Internal Power Supply Model)						B Contact Input (External Power Supply Model, Double Redundant)						
Speed setting	1mm/sec and up, the maximum depends on actuator specifications												
Acceleration/Deceleration Setting	0.01G and up, the maximum depends on the actuator												
Programming language	Super SEL language												
Number of programs	128 Programs												
Number of program steps	9999 Steps (total)												
Number of multi-tasking programs	16 Programs												
Number of Positions	20,000 Positions (Total)												
Data memory device	FLASH ROM+SRAM Battery Backup												
Data input method	Teaching pendant or PC software												
Standard Input/Output	48-point I/O PIO Board (NPN/PNP), 96-point I/O PIO Board (NPN/PNP), 1 board can be installed												
Expansion Input/Output	48-point I/O PIO Board (NPN/PNP), 96-point I/O PIO Board (NPN/PNP), Up to 3 boards can be installed												
Serial communications function	Teaching Pendant (25-pin D-sub) Port + 2ch RS232C Port (9-pin D-sub x 2)												
Protection function	Motor overcurrent, overload, motor driver temperature check, overload check encoder open-circuit check, soft limit over, system error, battery error, etc.												
Ambient Operating Temp. Humidity, Atmosphere	0 to 40°C, 10 to 95% (non-condensing). Free from corrosive gases. In particular, there shall be no significant dust.												
Weight (*2)	5.2kg				5.7kg				4.5kg				5kg
Accessory	I/O Flat Cable												

*1 When the connected axes represent the maximum wattage.

*2 Including the absolute-data backup battery, brake mechanism and expansion I/O box.

591 XSEL

External Dimensions

■ J (Compact) Type / K (General Purpose) Type

	1-axis specification	2-axis specification	3/4-axis specification	Side View
J type (Compact Type)				
K type (General Purpose Type)				

■ P (high-capacity standard type) / Q (high-capacity global type)

The XSEL-P/Q types have different shapes and dimensions in accordance with the controller specifications (encoder type, with/without brake, and with/without I/O expansion).

The 4 layouts below are available. Confirm dimensions to match the desired type and number of axes.

Caution
The specifications of the single phase 200V in Q type is the exterior dimension of P type.

[P Type]

		Basic Layout (Incremental Specification)	With brake/absolute unit	Basic Layout + I/O expansion base	With brake/absolute unit + I/O expansion base	Side View
Controllers Specifications	Encoder	Incremental	Absolute	Incremental	Absolute	
	Brake	None	Yes	None	Yes	
	I/O	Standard only	Standard only	Standard + Expansion	Standard + Expansion	
Single phase Specifications	1 to 4 axis Specifications					
	5 to 6 axis Specifications					
3 phases Specifications	1 to 4 axis Specifications					
	5 to 6 axis Specifications					

- Slider Type
- Mini
- Standard
- Controllers Integrated
- Pcd Type
- Mini
- Standard
- Controllers Integrated
- Table/Arm /FlatType
- Mini
- Standard
- Gripper/ Rotary Type
- Linear Servo Type
- Cleanroom Type
- Splash-Proo
- Controllers**
- PMEC /AMEC
- PSEP /ASEP
- ROBO NET
- ERC2
- PCON
- ACON
- SCON
- PSEL
- ASEL
- SSEL
- XSEL**
- Pulse Motor
- Servo Motor (24V)
- Servo Motor (200V)
- Linear Servo Motor

External dimensional drawing

[Q Type]

		Basic Layout (Incremental Specification)	With brake/absolute unit	Basic Layout + I/O expansion base	With brake/absolute unit + I/O expansion base	Side View
Controllers Specifications	Encoder	Incremental	Absolute	Incremental	Absolute	
	Brake	None	Yes	None	Yes	
	I/O	Standard only	Standard only	Standard + Expansion	Standard + Expansion	
Single phase Specifications	1 to 4 axis Specifications					
	5 to 6 axis Specifications					
3 phase Specifications	1 to 4 axis Specifications					
	5 to 6 axis Specifications					

593 XSEL

- Slider Type
- Mini
- Standard
- Controllers Integrated
- Pod Type
- Mini
- Standard
- Controllers Integrated
- Table/Arm /FlatType
- Mini
- Standard
- Gripper/ Rotary Type
- Linear Servo Type
- Cleanroom Type
- Splash-Proof
- Controllers**
- PMEC /AMEC
- PSEP /ASEP
- ROBO NET
- ERC2
- PCON
- ACON
- SCON
- PSEL
- ASEL
- SSEL
- XSEL**
- Pulse Motor
- Servo Motor (24V)
- Servo Motor (200V)
- Linear Servo Motor

Part Names

J type (Compact)

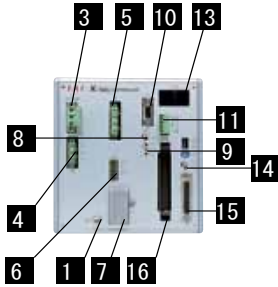

K type (General)

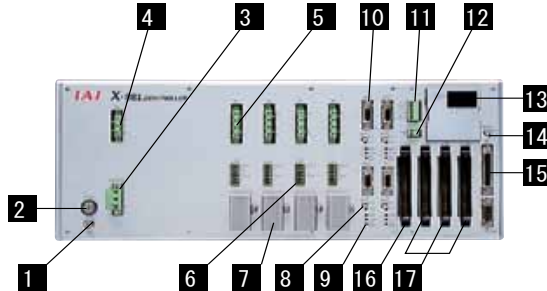

1 FG Connection Terminal

A terminal for connecting to the FG terminal on the enclosure. The PE of the AC input are connected to the enclosure inside the controller.

2 Fuse Holder (K Type only)

This is the single-pole fuse holder for overcurrent protection in the AC input.

3 Main Power Input Connector

This connector is for the AC100/200V single-phase input.

4 Regeneration Resistance Unit Connector

This connector is for the regenerative resistance unit (optional/REU-1) that is connected when there is insufficient capacity with the built-in regenerative resistor for high-acceleration/high-loads, etc.

5 Motor Cable Connector

A connector for the motor power-supply cable of the actuator.

6 Actuator Sensor Input Connector

A connector for axis sensors such as LS, CREEP and OT.

7 Absolute-data backup battery

This is the encoder backup battery unit when an absolute encoder is used. This battery is not connected for a non-absolute axis.

8 Brake Release Switch (Brake-equipped specification only)

Locking toggle switch for releasing the axis brake. Pull the switch forward and then tilt it up or down. Set the switch to the top position (RLS) to forcibly release the brake, or to the bottom position (NOM) to have the brake automatically controlled by the controller.

9 Axis Driver Status LED

This LED is for monitoring the operating status of the driver CPU that controls the motor drive. Features the following three LEDs..

Name	Color	Function description
ALM	Orange	Indicates when an error has been detected by the driver.
SVON	Green	Indicates that the servo is ON and the motor is driven.
BATT ALM	Orange	Indicates low absolute battery charge.

10 Encoder sensor cable connector

15-pin D-sub connector for the actuator encoder cable.

11 System I/O Connector

A connector for three input/output points including two inputs used to for the controller operation, and one system status output.

Name		
EMG	Emergency stop input	ON=operation enabled, OFF=emergency stop
ENB	Safety Gate Input	ON=operation enabled, OFF=servo OFF
RDY	System Ready Relay Output	This signal outputs the status of this controller. Cascade connection is supported. Short=ready, Open=not ready

12 I/O 24V Power Connector (K Type only)

16, **17** This connector is for supplying external I/O power to the insulator when DIs and DOs are installed in the I/O boards.

13 Panel Window

This window has a 4-digit, 7-segment LED and five LED lamps showing the system status.

14 Mode switch

This is a locking toggle switch for designating the controller operating mode. Pull the switch forward and then tilt it up or down.

The top position indicates the MANU (manual operation) mode, while the bottom position indicates the AUTO (automatic operation) mode. Teaching can only be performed in manual operation, and automatic operation using external I/Os is not possible in the MANU mode.

15 Teaching Connector

This is a 25-pin D-sub connector for connecting a teaching pendant or PC cable to enter programmed positions.

16 Standard I/O Slot (Slot 1)

A 32-point input / 16-point output PIO board is installed as standard equipment.

17 Expansion I/O Slots (Slot 2, Slot 3, Slot 4)

Install an expansion I/O board. (Option)

- Slider Type
- Mini
- Standard
- Controllers Integrated
- Pcd Type
- Mini
- Standard
- Controllers Integrated
- Table/Arm /FlatType
- Mini
- Standard
- Gripper/ Rotary Type
- Linear Servo Type
- Cleanroom Type
- Splash-Prod
- Controllers
- PMEC /AMEC
- PSEP /ASEP
- ROBO NET
- ERC2
- PCON
- ACON
- SCON
- PSEL
- ASEL
- SSEL
- XSEL
- Pulse Motor
- Servo Motor (24V)
- Servo Motor (200V)
- Linear Servo Motor

Part Names

Type P (Standard 4-axis)

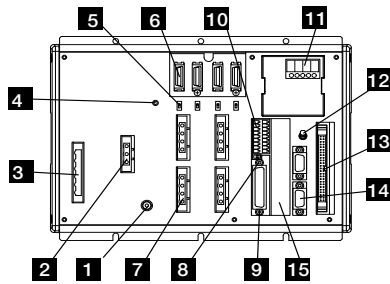

Type Q (Absolute brake unit + expansion base, 6-axis)

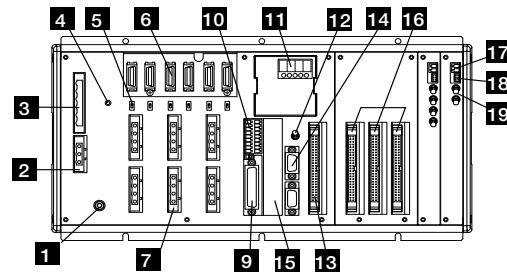

1 FG Connection Terminal

A terminal for connecting to the FG terminal on the enclosure. The PE of the AC input are connected to the enclosure inside the controller.

2 External regeneration unit connector

A connector for the regenerative resistor that must be connected when the built-in regenerative resistor alone does not offer sufficient capacity in high-acceleration/ high-load operation, etc. Whether or not an external regenerative resistor is necessary depends on the conditions of your specific application such as the axis configuration.

3 AC Power Input Connector

AC200V 3-phase input connector. It consists of six terminals including motor power-supply, control power-supply and PE terminals. Standard equipment only includes a terminal block.

Due to risk of electrical shock, do not touch this connector while power is supplied.

4 Control Power Monitor LED

A green light illuminates while the control power supply is properly generating internal controller power.

5 Enable/Disable Switch for Absolute Battery

This switch is for enabling/disabling the encoder backup using the absolute data backup battery. The encoder backup has been disabled prior to shipment. After connecting the encoder/axis-sensor cables, turn on the power, and then set this switch to the top position.

6 Encoder/Axis Sensor Connector

A connector for axis sensors such as LS, CREEP and OT. *: LS, CREEP, and OT are options.

7 Motor connector

A connector for driving the motor in the actuator.

8 Teaching Pendant Type Selection Switch

This switch is for selecting the type of teaching pendant to connect to the teaching connector. Switch between an IAI standard teaching pendant and the ANSI-compatible teaching pendant. Operate the switch on the front face of the board in accordance with the teaching pendant used.

9 Teaching Connector

The teaching interface is used for connecting the IAI teaching pendant or the software on a PC to operate and configure the system, etc.

10 System I/O connector

A connector for managing the safety operation functions of the controllers. Controllers of the global specification let you configure a safety circuit conforming to safety categories of up to 4 using this connector and an external safety circuit.

11 Panel Window

This window consists of a 4-digit, 7-segment LED and five LED lamps showing the system status.

Description of five LEDs

Name	Status when LED is lit
RDY	CPU Ready (programs can be run)
ALM	CPU Power (System Down Level Error) CPU Hardware Problem
EMG	Emergency stop status, CPU hardware problem, or power system hardware problem
PSE	Power supply hardware problem
CLK	System clock problem

12 Mode switch

This is a locking toggle switch for designating the controller operating mode. Pull the switch forward and then tilt it up or down. The top position indicates the MANU (manual operation) mode, while the bottom position indicates the AUTO (automatic operation) mode. Teaching can only be performed in manual operation, and automatic operation using external I/Os is not possible in the MANU mode.

13 Standard I/O connector

50-pin flat connector structure, comprised of 32 input / 16 output DIOs.

Overview of Standard I/O Interface Specifications

Item	Details
Connector Name	I/O
Applicable connector	50-Pins, Flat Connector
Power Supply	Power is supplied through connector pins No. 1 and No. 50.
Input	32 points (including general-purpose and dedicated inputs)
Output	16 points (including general-purpose and dedicated inputs)
Connected to	External PLC, sensors, etc.

14 General-purpose RS232C Port Connector

This port is for connecting general-purpose RS232C equipment. (2-channels are available)

15 Field network board slot

A slot that accepts a fieldbus interface module.

16 Expansion I/O Board (optional)

Slots that accept optional expansion I/O boards.

17 Brake Power Input Connector

A power input connector for driving the actuator brake. DC 24V must be supplied externally. If this power supply is not provided, the actuator brake cannot be released. Be certain that power is supplied to the brake-equipped axis. Use a shielded cable for the brake power cable, and connect the shielding on the 24V power supply side.

18 Brake Release Switch Connector

A connector for the switch that releases the actuator brake externally to the controller. Shorting the COM terminal and BKML* terminal of this connector will release the brake. Use this method if you wish to manually operate the actuator after the controller has experienced a power failure or malfunction.

19 Brake Switch

Locking toggle switch for releasing the axis brake. Pull the switch forward and then tilt it up or down. Setting it to the top position (RLS side) forcibly releases the brake, while setting it to the bottom position (NOM side) causes the controller to automatically control the brake.

595

XSEL

- Slider Type
- Mini
- Standard
- Controllers Integrated
- Pod Type
- Mini
- Standard
- Controllers Integrated
- Table/Arm /FlatType
- Mini
- Standard
- Gripper/ Rotary Type
- Linear Servo Type
- Cleanroom Type
- Splash-Proof
- Controllers
- PMEC /AMEC
- PSEP /ASEP
- ROBO NET
- ERC2
- PCON
- ACON
- SCON
- PSEL
- ASEL
- SSEL
- XSEL
- Pulse Motor
- Servo Motor (24V)
- Servo Motor (200V)
- Linear Servo Motor

Option

Regenerative Resistance Unit

Model **REU-1**

Details

This unit converts to heat the regenerative current produced when the motor decelerates. Although the controller has a built-in regenerative resistor, its capacity may not be enough if the axis is positioned vertically and the load is large. In this case, one or more regenerative units will be required. (Refer to the table at right)

Specifications

Item	Specifications
Main Unit dimensions	W34mm x H195mm x D126mm
Main Unit Weight	900g
Built-in regenerative resistor	220Ω 80W
Accessory	Controller Connection Cable (Model No. CB-ST-REU010) 1m

Installation Standards

Determined by the total motor capacity of vertical axes connected.

Horizontal Application

Number of connecting units	P/Q Type	J Type	K Type
0 pc	to 100W	to 200W	to 800W
1 pc	to 600W	to 800W	to 1200W
2 pc	to 1200W	-	to 1600W
3 pc	to 1800W	-	-
4 pc	to 2400W	-	-

Vertical Application

Number of connecting units	P/Q Type	J Type	K Type
0 pc	to 100W	to 200W	to 400W
1 pc	to 600W	to 600W	to 800W
2 pc	to 1000W	to 800W	to 1200W
3 pc	to 1400W	-	When exceeding 1200W, please contact IAL.
4 pc	to 2000W	-	
5 pc	to 2400W	-	

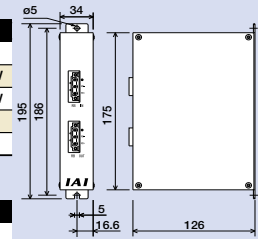

Absolute Data Retention Battery (For XSEL-J/K/KE/KT/KET)

Model **IA-XAB-BT**

Features

A battery that retains the data stored in an absolute type controller. Replace when the controller battery alarm illuminates.

Packaging

1 Unit (One battery is required for each axis. Specify a quantity for the number of axes used.)



Absolute Data Retention Battery (For XSEL-P/Q)

Model **AB-5**

Features

Absolute data retention battery for operating actuators under absolute specification.



Expansion PIO Board

Details

An optional board for adding I/O (input/output) points. With the general-purpose and large-capacity types, up to three expansion PIO boards can be installed in the expansion slots. (With the compact types, only one expansion PIO board can be installed in the expansion slot, provided that the controller is of 3 or 4-axis specification.)

Expansion SIO Board (General-Purpose Type)

Model/Specifications

IA-105-X-MW-A (for RS232C connection) (Board + joint cables (1), 2 included)
IA-105-X-MW-B (for RS422 connection) (Board + joint cables (2), 1 included)
IA-105-X-MW-C (for RS485 connection) (Board + joint cables (2), 1 included)

Details

Board for serial communications with external equipment. This board has two port channels and implements three communication modes using the supplied joint cable(s).

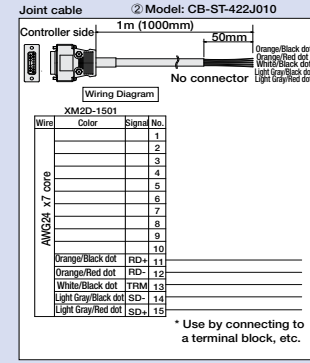
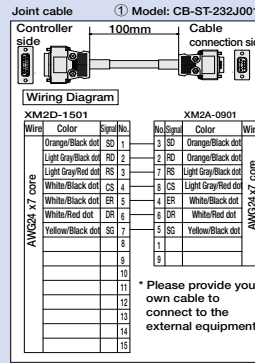

DeviceNet Connection Board

A board for connecting the XSEL controller to DeviceNet.

Item	Specifications			
Number of I/O Points	1 board, 256 input points / 256 output points *Only 1 can be installed			
Communication Standard	Interface module certified under DeviceNet 2.0 (certification to be obtained)			
	Group 2 Only Server			
Communication specifications	Insulated node operating on network power supply			
	Master-Slave connection	Bit strobe		
		Polling		
		Cyclic		
Communication Rate	500k/250k/125kbps (Selectable by DIP switch)			
Communication cable length	Communication Rate	Maximum network length	Maximum branch length	Total branch length
	500 kbps	100m	6m	39m
	250 kbps	250m		78m
	125 kbps	500m		156m
(Note) When a large DeviceNet cable is used				
Communication Power Supply	24VDC (supplied from DeviceNet)			
Low Current Communication Power Supply	60mA or higher			
Number of Reserved Nodes	1 node			
Connector	MSTBA2.5/5-G.08AUM by Phoenix Contact (*1)			

(*1) The connector on the cable (SMSTB2.5/5-ST-5.08AU by Phoenix Contact) is a standard accessory.

CC-Link Connection Board

A board for connecting the XSEL controller to CC-Link.

Item	Specifications					
Number of I/O Points	1 board, 256 input points / 256 output points *Only 1 can be installed					
Communication Standard	CC-Link Ver1.10 (certified)					
Communication Rate	10M/5M/2.5M/625k/156kbps (switched using a rotary switch)					
Communication method	Broadcast polling method					
Asynchronous	Frame synchronization method					
Encoding Format	NRZI					
Transmission path type	Bus Format (EIA RS485 Compliant)					
Transmission Format	HDLCL Compliant					
Error control method	CRC (X ¹⁶ +X ⁵ +X ² +X ¹)					
Number of Reserved Stations	1 to 3 Stations (Remote Device Stations)					
Communication cable length	Communication Rate (bps)	10M	5M	2.5M	625k	156k
	Communication cable length	100	160	400	900	1200
Connector (Controller-side)	MSTBA2.5/5-G.08AUM by Phoenix Contact (*1)					

(*1) The connector on the cable (SMSTB2.5/5-ST-5.08AU by Phoenix Contact) is a standard accessory.

- Slider Type
- Mini
- Standard
- Controllers Integrated
- Pcd Type
- Mini
- Standard
- Controllers Integrated
- Table/Arm /FlatType
- Mini
- Standard
- Gripper/ Rotary Type
- Linear Servo Type
- Cleanroom Type
- Splash-Proof
- Controllers
- PMEC /AMEC
- PSEP /ASEP
- ROBO NET
- ERC2
- PCON
- ACON
- SCON
- PSEL
- ASEL
- SSEL
- XSEL
- Pulse Motor
- Servo Motor (24V)
- Servo Motor (200V)
- Linear Servo Motor

Part Names

Teaching Pendant

Model IA-T-X (standard)

Dimensions

IA-T-XD (with deadman switch)

- Features**
- A teaching device that has program/position input, test operation, monitoring function, etc.
 - Interactive, easy to operate.
 - For higher safety, a deadman switch version is also available.

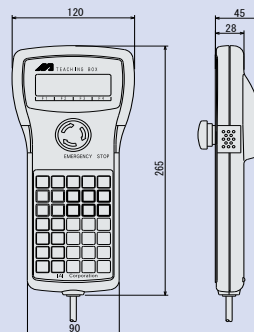

Specifications

Item	Specifications
Ambient Operating Temp./Humidity	Temperature 0 to 40°C, Humidity: 85 %RH or lower
Ambient Operating atmosphere	Free from corrosive gases. In particular, there shall be no significant powder dust.
Weight	Approx. 650g
Cable Length	4m
Indication	20 characters x 4 lines LCD display

Note:

- * Versions older than 1.13 cannot be used with XSEL-P/Q.
- * Versions older than 1.08 cannot be used with SCARA.

ANSI standard / CE mark compatible teaching pendant (dedicated to general purpose type)

Model SEL-T

Dimensions

SEL-TD (Corresponding to ANSI)

SEL-TG (Corresponding to safety category)

- Features**
- Splash-proof type that corresponds to protection level IP54. Improved operability with separate keys for different functions. In addition, SEL-TD / SEL-TG has a 3-position enable switch and corresponds to ANSI standard.

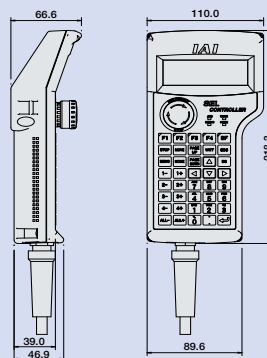

Specifications

Item	Specifications
Ambient Operating Temp./Humidity	Temperature: 0 to 40°C Humidity: 30 to 85%RH or lower (non-condensing)
Protection mechanism	IP54 (Cable connector excluded)
Weight	400g or lower (Cable connector excluded)
Cable Length	5m
Indication	32 characters x 8 lines LCD display
Safety Rating	CE mark, ANSI standard (*)

(*) only SEL-TD / SEL-TG corresponds to ANSI standard.

Teaching pendant controller correspondence table

		IA-T-X	IA-T-XD	SEL-T	SEL-TD	SEL-TG
		Standard	With a deadman switch	Standard	Safety Category Compliant	Safety Category Compliant
Program Controllers	PSEL/ASEL/SSEL	○ (Note 1)	○ (Note 1)	○ (Note 1)	○ (Note 1)	○
	XSEL-J	○	○	×	×	○ (Note 2)
	XSEL-K	○	○	○	○	○
	XSEL-P	○	○	○	○	○
	XSEL-Q	×	×	○	○	○
	XSEL-KT	○	○	○	○	○
	XSEL-KE	○	○	○	○	○
	XSEL-JX	○	○	×	×	○ (Note 2)
	XSEL-KX	○	○	○	○	○
	XSEL-PX	○	○	○	○	○
	XSEL-QX	×	×	○	○	○

* ○ corresponds to safety category B to 4.

○ does not correspond to safety category, but connection is available.

(Note 1) To connect to PSEL/ASEL/SSEL, a conversion cable is necessary.

(Note 2) To connect SEL-TG to the XSEL-J/JX controller, DC24V needs to be applied to TP adaptor.

SEL-TG wiring drawing

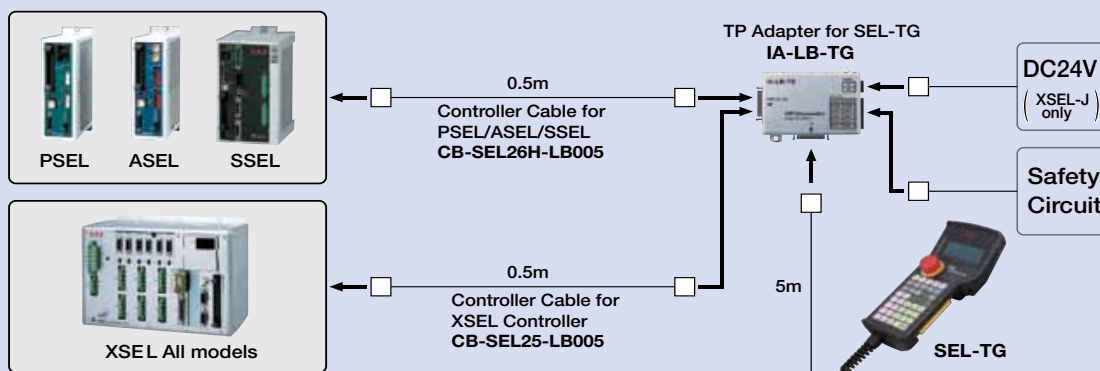

597

XSEL

- Slider Type
- Mini
- Standard
- Controllers Integrated
- Rod Type
- Mini
- Standard
- Controllers Integrated
- Table/Arm /FlatType
- Mini
- Standard
- Gripper/ Rotary Type
- Linear Servo Type
- Cleanroom Type
- Splash-Proof
- Controllers
- PMEC /AMEC
- PSEP /ASEP
- ROBO NET
- ERC2
- PCON
- ACON
- SCON
- PSEL
- ASEL
- SSEL
- XSEL
- Pulse Motor
- Servo Motor (24V)
- Servo Motor (200V)
- Linear Servo Motor

PC software (Windows dedicated)

Model IA-101-X-MW (DOS/V ver.)

Note:
 * Versions older than 3.0.0 cannot be used with XSEL-P/Q.
 * Versions older than 2.0.0 cannot be used with SCARA.
 * Please use IA-101-XA-MW for safety category 4-compliant controller.

Features A startup support software program offering program/position input function, test operation function, monitoring function, and more.
 The functions needed for debugging have been enhanced to help reduce the startup time.

Details Software (CD-ROM)
 (Corresponding to Windows98, NT, 2000, ME, and XP)
 PC connecting cable 5m + Emergency stop box (Model: CB-ST-E1MW050-EB)

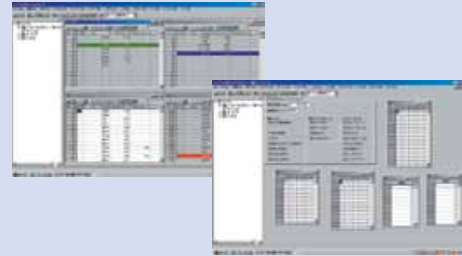

PC connecting cable single unit (Model: CB-ST-E1MW050)

Note:
 When ordering a separate replacement PC cable, the model number for cable only is CB-ST-E1MW050, and for cable with emergency stop box is CB-ST-E1MW050-EB.

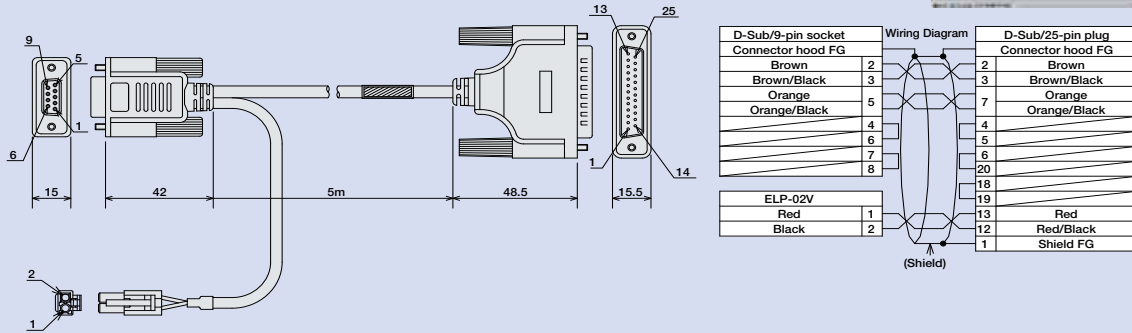

Safety Category 4-compatible PC Software

Model IA-101-XA-MW (DOS/V version)

Features A startup support software program offering program/position input function, test operation function, monitoring function, and more.
 The functions needed for debugging have been enhanced to help reduce the startup time.
 PC connecting cable is compatible to safety category 4 by duplicating the emergency stop circuits.

Details Software (CD-ROM)
 (Accessory) * Corresponding to Windows98, NT, 2000, ME, and XP
 PC connecting cable 5m + Emergency stop box (Model: CB-ST-A1MW050-EB)

Dimensions PC connecting cable (Model: CB-ST-A1MW050)

* Cannot be used with XSEL-J/JX/K/KE/KX/P/PX

Note:
 When ordering a separate replacement PC cable, the model number for cable only is CB-ST-A1MW050, and for cable with emergency stop box is CB-ST-A1MW050-EB.

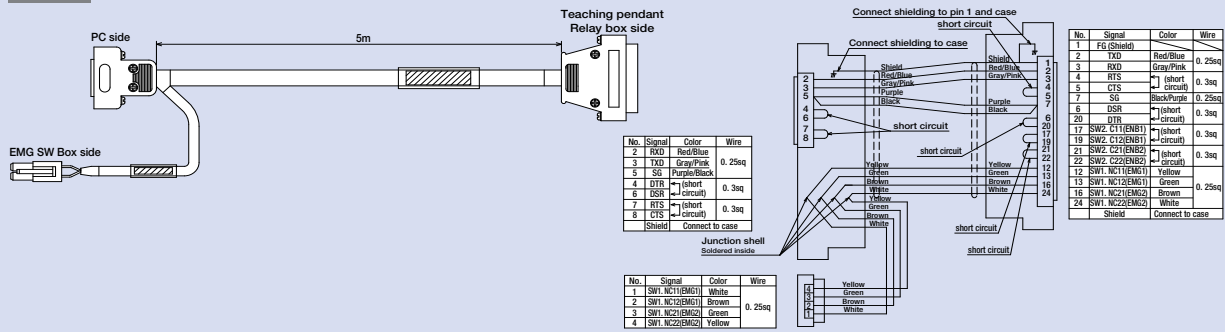

USB-compatible PC software

Model IA-101-X-USBMW

Features Software available by PC USB port by connecting a USB conversion adaptor to a RS232C cable.

Details Software (CD-ROM)
 * Corresponding to Windows98, NT, 2000, ME, and XP
 PC connecting cable 5m + Emergency stop box + USB conversion adaptor + USB cable 3m

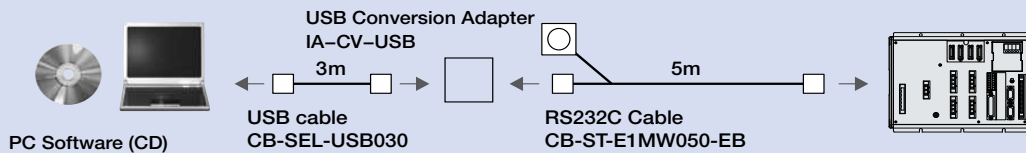

- Slider Type
- Mini
- Standard
- Controllers Integrated
- Pcd Type
- Mini
- Standard
- Controllers Integrated
- Table/Arm /FlatType
- Mini
- Standard
- Gripper/ Rotary Type
- Linear Servo Type
- Cleanroom Type
- Splash-Proof
- Controllers
- PMEC /AMEC
- PSEP /ASEP
- ROBO NET
- ERC2
- PCON
- ACON
- SCON
- PSEL
- ASEL
- SSEL
- XSEL
- Pulse Motor
- Servo Motor (24V)
- Servo Motor (200V)
- Linear Servo Motor

Spare Parts

When you need spare parts after purchasing the product, such as when replacing a cable, refer to the list of models below.

Motor cable/Motor robot cable

Model **CB-RCC-MA** □□□□ / **CB-RCC-MA** □□□□ **-RB**

* Enter the cable length (L) into □□□□. Compatible to a maximum of 20 meters.
Ex.: 080 = 8 m

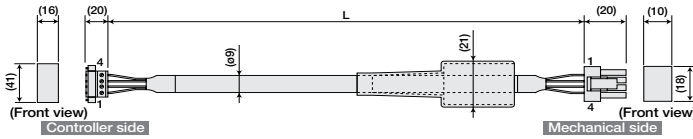

Wire	Signal	No.	No.	Signal	Wire
0.75sq	PE	1	1	U	0.75sq (crimped)
	U	2	2	V	
	V	3	3	W	
	W	4	4	PE	

Min. bend radius $r = 50$ mm or larger (when movable type is used)
* Only the robot cable is to be used in a cable track

Encoder cable/Encoder robot cable (for XSEL-J/K)

Model **CB-RCBC-PA** □□□□ / **CB-RCBC-PA** □□□□ **-RB**

* Enter the cable length (L) into □□□□. Compatible to a maximum of 15 meters.
Ex.: 080 = 8 m

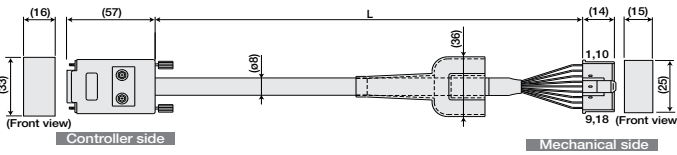

Wire	Signal	No.	No.	Signal	Wire
0.15sq (crimped)	A/U	1	1	A/U	0.15sq (crimped)
	A/U	2	2	A/U	
	B/V	3	3	B/V	
	B/V	4	4	B/V	
	Z/W	5	5	Z/W	
	Z/W	6	6	Z/W	
	SD	7	7	-	
	SD	8	8	-	
	BAT+	9	9	FG	
	BAT-	10	10	SD	
	VCC	11	11	SD	
	GND	12	12	BAT+	
	BK-	13	13	BAT-	
	BK+	14	14	VCC	
	-	15	15	GND	
-	-	16	-		
-	-	17	BK-		
-	-	18	BK+		

The shield is connected to the hood by a clamp.
Ground wire and shield braiding

Min. bend radius $r = 50$ mm or larger (when movable type is used)
* Only the robot cable is to be used in a cable track

Encoder cable/Encoder robot cable (for XSEL-P/Q)

Model **CB-RCS2-PA** □□□□ / **CB-X3-PA** □□□□

* Enter the cable length (L) into □□□□. Compatible to a maximum of 20 meters.
Ex.: 080 = 8 m

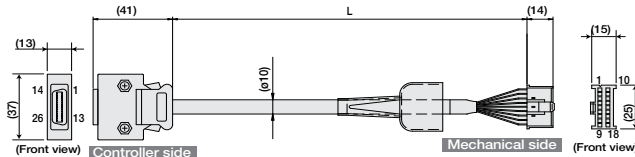

Wire	Color	Signal	No.	No.	Signal	Color	Wire
AWG26 (twisted)	-	-	10	1	A	Pink	AWG26 (crimped)
	-	-	11	2	A	Purple	
	-	E24W	12	3	B	White	
	Gray/White	0V	13	4	B	Black/Red	
	Brown/White	LS	26	5	Z	Orange/White	
	-	GREEP	25	6	Z	Green/White	
	-	0T	24	7	LS+	Brown/White	
	-	RSW	23	8	-	-	
	-	-	9	9	FG	Ground	
	-	-	16	10	SD	Blue	
	-	-	19	11	SD	Orange	
	Pink	A+	1	12	BAT+	Black	
	Purple	A-	2	13	BAT-	Yellow	
	White	B+	3	14	VCC	Green	
	Black/Red	B-	4	15	GND	Brown	
	Orange/White	Z+	5	16	LS-	Gray/White	
	Green/White	Z-	6	17	BK-	Gray	
	Blue	SRD+	7	18	BK+	Red	
	Orange	SRD-	8	-	-	-	
	Black	BAT+	14	-	-	-	
	Yellow	BAT-	15	-	-	-	
	Brown	GND	17	-	-	-	
Gray	BK-	20	-	-	-		
Red	BK+	21	-	-	-		
-	-	22	-	-	-		

The shield is connected to the hood by a clamp.
Ground wire and shield braiding

Min. bend radius $r = 50$ mm or larger (when movable type is used)
* Only the robot cable is to be used in a cable track

599 XSEL

Spare Parts

Rotary Dedicated Encoder Cable / Encoder Robot Cable

Model **CB-RCS2-PLA** / **CB-X2-PLA**

* Enter the cable length (L) into . Compatible to a maximum of 30 meters.
Ex.: 080 = 8 m

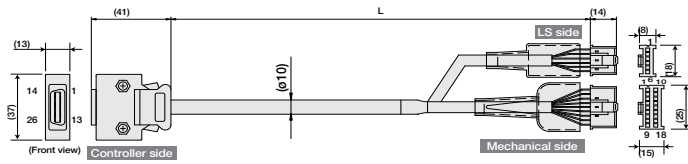

Min. bend radius $r = 50$ mm or larger (when movable type is used)
* Only the robot cable is to be used in a cable track

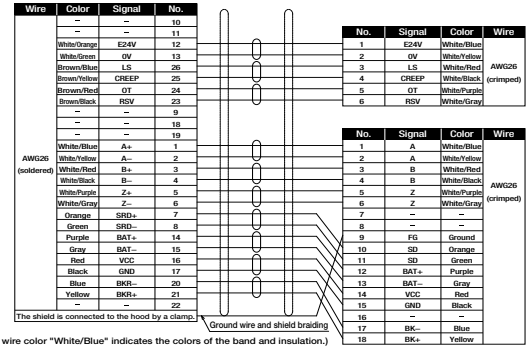

Encoder cable (when using a XSEL-J/K type a homing sensor is used)

Model **CB-RCBC-PLA**

* Enter the cable length (L) into . Compatible to a maximum of 20 meters.
Ex.: 080 = 8 m

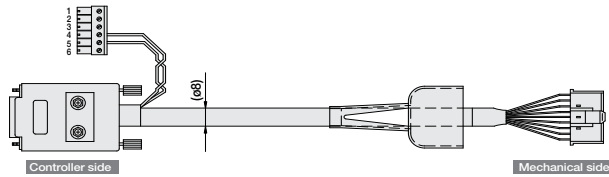

*This cable is a standard type.

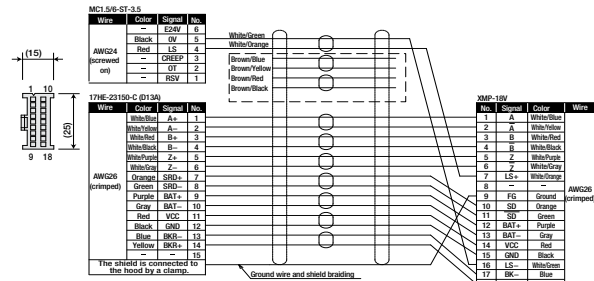

I/O flat cable (for XSEL-J/K/P/Q)

Model **CB-X-PIO**

* Enter the cable length (L) into . Compatible to a maximum of 10 meters.
Ex.: 080 = 8 m

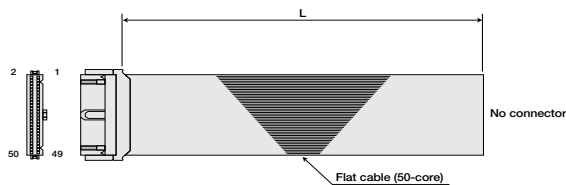

XSEL 600

- Slider Type
- Mini
- Standard
- Controllers Integrated
- Pcd Type
- Mini
- Standard
- Controllers Integrated
- Table/Arm /FlatType
- Mini
- Standard
- Gripper/ Rotary Type
- Linear Servo Type
- Cleanroom Type
- Splash-Proof
- Controllers
- PMEC /AMEC
- PSEP /ASEP
- ROBO NET
- ERC2
- PCON
- ACON
- SCON
- PSEL
- ASEL
- SSEL
- XSEL
- Pulse Motor
- Servo Motor (24V)
- Servo Motor (200V)
- Linear Servo Motor