

# RCS2W-RA4C/RA4D/RA4R

ROBO Cylinder Splash-proof Rod Type  
 ø37mm Diameter 200V Servo Motor  
 Coupled/Built-in/Side-Mounted Motor Specification

■ Configuration: **RCS2W** — [ ] — [ ] — [ ] — [ ] — [ ] — [ ] — [ ] — [ ]

Series — Type — Encoder — Motor — Lead — Stroke — Compatible Controllers — Cable Length — Option

RA4C: Coupled type  
 RA4D: Built-in  
 RA4R: Side-Mounted Motor

I : Incremental Type  
 A : Absolute Type

20 : 20W servo motor  
 30 : 30W servo motor

12 : 12mm  
 6 : 6mm  
 3 : 3mm

50:50mm  
 300:300mm (50mm pitch increments)

T1 : XSEL-J/K  
 T2 : SCON  
 SSEL  
 XEL-P/Q

N : None  
 P : 1m  
 S : 3m  
 M : 5m  
 X [ ] : Custom Length  
 R [ ] : Robot Cable

See Options below

\* See page Pre-35 for explanation of each code that makes up the configuration name.

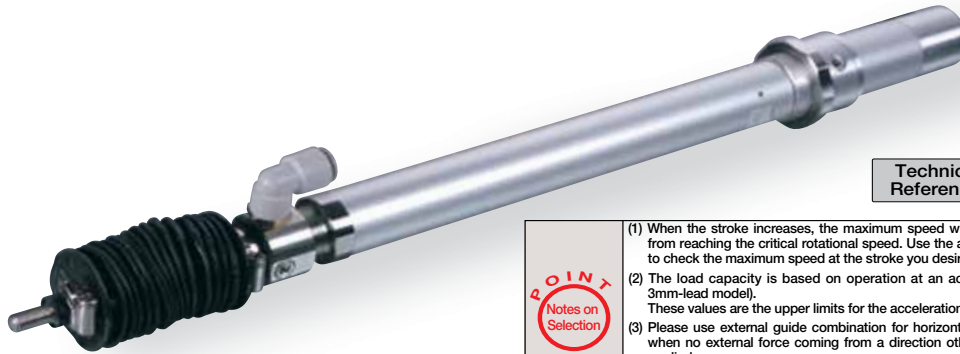

Technical References P. A-5

- Notes on Selection**
- When the stroke increases, the maximum speed will drop to prevent the ball screw from reaching the critical rotational speed. Use the actuator specification table below to check the maximum speed at the stroke you desire.
  - The load capacity is based on operation at an acceleration of 0.3G (0.2G for the 3mm-lead model). These values are the upper limits for the acceleration.
  - Please use external guide combination for horizontal load capacity; the value is for when no external force coming from a direction other than that of rod's advance is applied.
  - The cable joint connector is not splash-proof; secure it in a place that is not prone to water spills.

Actuator Specifications						
■ Lead and Load Capacity						
Model	Motor Output (W)	Lead (mm)	Max. load capacity Horizontal(kg) Vertical(kg)	Rated thrust (N)	Stroke (mm)	
RCS2W-①-②-20-12-③-④-⑤-⑥	20	12	3.0 / 1.0	18.9	50-300 (50mm increments)	
RCS2W-①-②-20-6-③-④-⑤-⑥		6	6.0 / 2.0	37.7		
RCS2W-①-②-20-3-③-④-⑤-⑥		3	12.0 / 4.0	75.4		
RCS2W-①-②-30-12-③-④-⑤-⑥	30	12	4.0 / 1.5	28.3		
RCS2W-①-②-30-6-③-④-⑤-⑥		6	9.0 / 3.0	56.6		
RCS2W-①-②-30-3-③-④-⑤-⑥		3	18.0 / 6.5	113.1		

■ Stroke and Maximum Speed		
Stroke	50-300 (50mm increments)	
12	600	
6	300	
3	150	

(Unit: mm/s)

Legend ① Type ② Encoder ③ Stroke ④ Compatible controller ⑤ Cable length ⑥ Options

Encoder & Stroke List						
③ Stroke (mm)	Standard Price					
	RA4C/RA4D			RA4R		
	② Encoder Type		② Encoder Type		② Encoder Type	
	Incremental	Absolute	Incremental	Absolute	Incremental	Absolute
	Motor power output	Motor power output	Motor power output	Motor power output	Motor power output	Motor power output
	20W	30W	20W	30W	20W	30W
50	-	-	-	-	-	-
100	-	-	-	-	-	-
150	-	-	-	-	-	-
200	-	-	-	-	-	-
250	-	-	-	-	-	-
300	-	-	-	-	-	-

⑤ Cable List		
Type	Cable Symbol	Standard Price
Standard	P (1m)	-
	S (3m)	-
	M (5m)	-
Special Lengths	X06 (6m) ~ X10 (10m)	-
	X11 (11m) ~ X15 (15m)	-
	X16 (16m) ~ X20 (20m)	-
Robot Cable	R01 (1m) ~ R03 (3m)	-
	R04 (4m) ~ R05 (5m)	-
	R06 (6m) ~ R10 (10m)	-
	R11 (11m) ~ R15 (15m)	-
	R16 (16m) ~ R20 (20m)	-

\* See page A-39 for cables for maintenance.

⑥ Option List			
Name	Option Code	See Page	Standard Price
Brake (*1)	B	→ A-25	-
Flange bracket	FL	→ A-27	-
Foot bracket	FT	→ A-29	-
Home confirmation sensor (*2)	HS	→ A-32	-
Knuckle Joint	NJ	→ A-34	-
Reversed-home (*2)	NM	→ A-33	-
Clevis Bracket (*3)	QR	→ A-34	-
Rear mounting plate (*3)	RP	→ A-33	-
Trunnion Bracket (Front) (*4)	TRF	→ A-38	-
Trunnion Bracket (Back) (*4)	TRR	→ A-38	-

(\*1) No brake setting for RA4D.  
 (\*2) Home sensor (HS) can't be used under reversed-home (NM).  
 (\*3) Clevis bracket and rear mounting plate only available for RA4R.  
 (\*4) Trunnion bracket only available for RA4C/RA4D.

Actuator Specifications	
Item	Description
Drive System	Ball screw ø10mm C10 grade
Positioning Repeatability	±0.02mm
Lost Motion	0.1 mm or less
Base	Material: Aluminum (white alumite treated)
Rod diameter	ø20mm
Rod non-rotational accuracy	±1.0 degrees
Protection Structure	IP54
Ambient Operating Temp./Humidity	0-40°C, 85%RH or less (Non-condensing)

# 459

RCS2W-RA4C/RA4D/RA4R

Dimensions

CAD drawings can be downloaded from IAI website. [www.intelligentactuator.com](http://www.intelligentactuator.com)



Note: No 3D CAD data for RA4D type.

For Special Orders P. A-9

- \* 1 Cable joint connector and cable bending space are the same as for RCS2-RA4C. (See P236)
  - \* 2 When homing, the slider moves to the ME; therefore, please watch for any interference with the surrounding objects.
- ME: Mechanical end SE: Stroke end

[RA4C/RA4D]

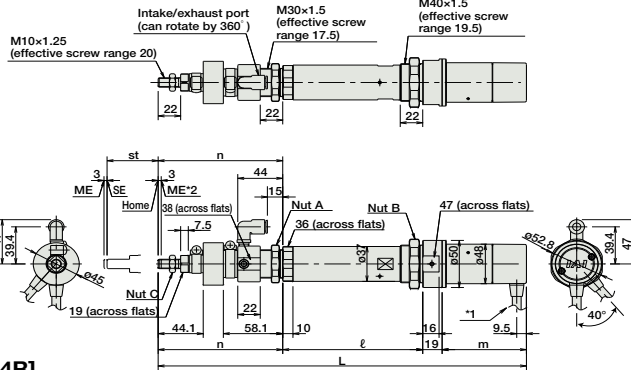

[RA4R]

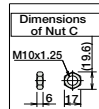
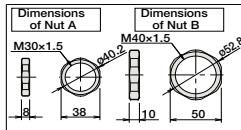
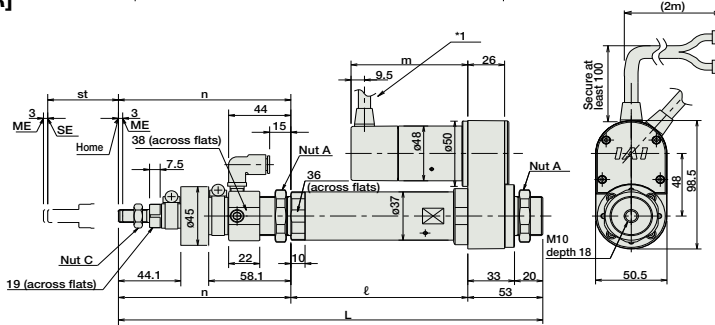

Dimensions/Weight by Stroke

RCS2W-RA4C/RA4D/RA4R (without brake)

L	Stroke	Stroke						
		50	100	150	200	250	300	
L	RA4C	20W	358.4	418.4	478.4	538.4	599.4	660.4
		30W	373.4	433.4	493.4	553.4	614.4	675.4
	RA4D	20W	336.4	396.4	456.4	516.4	577.4	638.4
r	RA4R	20W	299.9	359.9	419.9	479.9	540.9	601.9
		30W	299.9	359.9	419.9	479.9	540.9	601.9
	RA4C	20W	137	187	237	287	337	387
m	RA4D	20W	137	187	237	287	337	387
		30W	137	187	237	287	337	387
	RA4R	20W	125	175	225	275	325	375
n	RA4C	20W	125	175	225	275	325	375
		30W	125	175	225	275	325	375
	RA4D	20W	125	175	225	275	325	375
Weight (kg)	RA4C	20W/30W	1.4	1.5	1.7	1.8	2.0	2.1
		RA4D	20W/30W	1.3	1.5	1.6	1.8	1.9
	RA4R	20W/30W	1.5	1.7	1.8	2.0	2.1	2.3

RCS2W-RA4C/RA4D/RA4R (with brake)

L	Stroke	Stroke						
		50	100	150	200	250	300	
L	RA4C	20W	401.4	461.4	521.4	581.4	642.4	703.4
		30W	416.4	476.4	536.4	596.4	657.4	718.4
	RA4D	20W	No brake-equipped model.					
l	RA4R	20W	299.9	359.9	419.9	479.9	540.9	601.9
		30W	299.9	359.9	419.9	479.9	540.9	601.9
	RA4C	20W	137	187	237	287	337	387
m	RA4D	20W	No brake-equipped model.					
		30W	No brake-equipped model.					
	RA4R	20W	125	175	225	275	325	375
n	RA4C	20W	125	175	225	275	325	375
		30W	125	175	225	275	325	375
	RA4D	20W	No brake-equipped model.					
Weight (kg)	RA4C	20W/30W	1.6	1.7	1.9	2.0	2.2	2.3
		RA4D	20W/30W	-				
	RA4R	20W/30W	1.7	1.9	2.0	2.2	2.3	2.5

4 Compatible Controllers

The RCS2W series actuators can operate with the controllers below. Select the controller according to your usage.

Name	External View	Model	Description	Max. Positioning Points	Input Voltage	Power Supply Capacity	Standard Price	See Page
Positioner Mode		SCON-C-20 ①-NP-2-② SCON-C-30D ①-NP-2-②	Positioning possible for up to 512 points	512 points	Single-Phase AC 100V Single-Phase AC 200V 3-Phase AC 200V (XSEL-P/Q only)	Maximum 360VA *1 axis type When operating 150W	-	→ P547
Solenoid Valve Mode			Operation possible with the same controls as solenoid valve.	7 points				
Serial Communication Type			Dedicated to serial communication	64 points				
Pulse Train Input Control Type			Open Collector Pulse Train Input Type	(-)				
Program control 1-2 Axes type		SSEL-C-1-20 ①-NP-2-② SSEL-C-1-30D ①-NP-2-②	Programmed operation is possible Can operate up to 2 axes	20000 points				→ P577
Program control 1-6 Axes type		XSEL-③-1-20 ①-N1-EEE-2-④ XSEL-③-1-30D ①-N1-EEE-2-④	Programmed operation is possible Can operate up to 6 axes	20000 points				→ P587

- \* For SSEL and XSEL, only applicable to the single-axis model.
- \* ① is a placeholder for the encoder type (I: incremental, A: absolute).
- \* ② is a placeholder for the power supply voltage (1: 100V, 2: single-phase 200V)
- \* ③ is a placeholder for the XSEL type name (J, K, P, or Q)
- \* ④ is a placeholder for the power supply voltage (1: 100V, 2: single-phase 200V, 3: 3-phase 200V).



RCS2W-RA4C/RA4D/RA4R

460

- Slider Type
- Mini
- Standard
- Controllers Integrated
- Rod Type
- Mini
- Standard
- Controllers Integrated
- Table/Arm /Flat Type
- Mini
- Standard
- Cripper/ Rotary Type
- Linear Servo Type
- Cleanroom Type
- Splash Proof
- Controllers
- PMEC /AMEC
- PSEP /ASEP
- ROBO NET
- ERC2
- PCON
- ACON
- SCON
- PSEL
- ASEL
- SSEL
- XSEL
- Pulse Motor
- Servo Motor (24V)
- Servo Motor (200V)
- Linear Servo Motor