

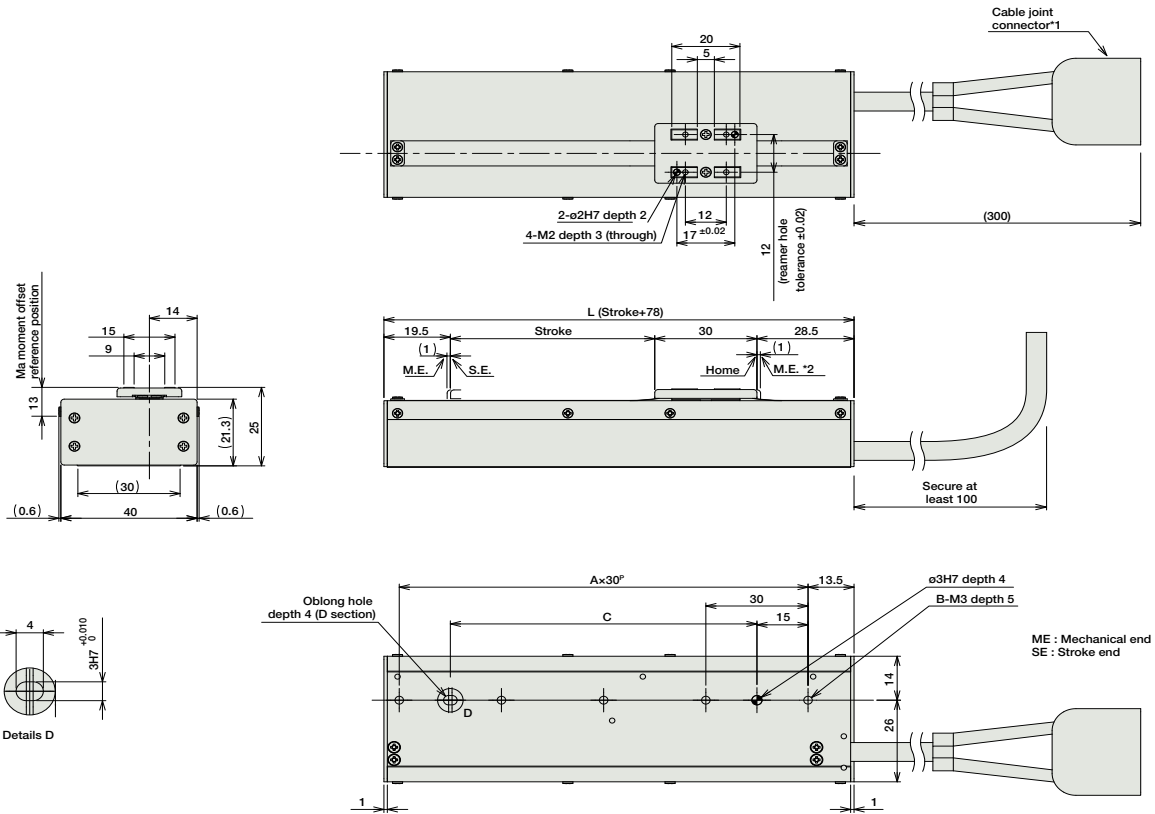

Dimensions

For Special Orders P. A-9



- \*1 The motor-encoder cable is connected here. See page A-39 for details on cables.
- \*2 When homing, the slider moves to the mechanical end; therefore, please watch for any interference with the surrounding objects.

■ Dimensions and Weight by Stroke

Stroke	30	60	90	120	150	180
L	108	138	168	198	228	258
A	3	4	5	6	7	8
B	4	5	6	7	8	9
C	60	90	120	150	180	210
Weight (kg)	0.21	0.25	0.29	0.32	0.36	0.4

② Compatible controller

The RCL series actuators can operate with the controllers below. Select the controller according to your usage.

Name	External View	Model	Description	Max. Positioning Points	Input Voltage	Power Supply Capacity	Standard Price	See Page
Solenoid Valve Type		AMEC-C-2I-NP-2-1	Easy-to-use controller, even for beginners	3 points	AC100V	2.4A rated	-	→ P477
		ASEP-C-2I-NP-2-0	Operable with same signal as solenoid valve. Supports both single and double solenoid types. No homing necessary with simple absolute type.					→ P487
Splash-Proof Solenoid Valve Type		ASEP-CW-2I-NP-2-0						
Positioner Type		ACON-C-2I-NP-2-0	Positioning is possible for up to 512 points	512 points	DC24V	4.6A max.	-	
Safety-Compliant Positioner Type		ACON-CG-2I-NP-2-0						
Pulse Train Input Type (Differential Line Driver)		ACON-PL-2I-NP-2-0	Pulse train input type with differential line driver support	(-)	DC24V	4.6A max.	-	→ P535
Pulse Train Input Type (Open Collector)		ACON-PO-2I-NP-2-0	Pulse train input type with open collector support					
Serial Communication Type		ACON-SE-2I-N-0-0	Dedicated to serial communication	64 points				
Field Network Type		RACON-2	Dedicated to field network	768 points				→ P503
Program Control Type		ASEL-C-1-2I-NP-2-0	Programmed operation is possible. Operation is possible on up to 2 axes	1500 points				→ P567

\* This is for the single-axis ASEL.

- Slider Type
- Mini
- Standard
- Controllers Integrated
- Rod Type
- Mini
- Standard
- Controllers Integrated
- Table/Arm /Flat Type
- Mini
- Standard
- Gripper/ Rotary Type
- Linear Servo Type
- Cleanroom Proof
- Splash Proof
- Controllers
- PMEC /AMEC
- PSEP /ASEP
- ROBO NET
- ERC2
- PCON
- ACON
- SCON
- PSEL
- ASEL
- SSEL
- XSEL
- Pulse Motor
- Servo Motor (24V)
- Servo Motor (200V)
- Linear Servo Motor