

# RCACR-SA4C

Cleanroom ROBO Cylinder Slider Coupling Type 40mm Width 24V Servo Motor Aluminum Base

■ Configuration: **RCACR-SA4C** —  — **20** —  —  —  —  —

Series — Type — Encoder — Motor — Lead — Stroke — Compatible Controllers — Cable Length — Option

I: Incremental  
A: Absolute  
\* The absolute model can only use ASEL. The simple absolute type is considered an incremental model.

20: 20W servo motor  
10: 10mm  
5: 5mm  
2.5: 2.5mm

50: 50mm  
400: 400mm (50mm pitch increments)

A1: ACON  
RACON  
ASEL  
A3: AMEC  
ASEP

N: None  
P: 1m  
S: 3m  
M: 5m  
X  : Custom  
R  : Robot cable

See Options below

\* See page Pre-35 for an explanation of the naming convention.

**Power-saving**



**Technical References** P. A-5

- POINT** Notes on Selection
- When the stroke increases, the maximum speed will drop to prevent the ball screw from reaching the critical rotational speed. Use the actuator specification table below to check the maximum speed at the stroke you desire.
  - The load capacity is based on operation at an acceleration of 0.3G (0.2G for the 2.5mm-lead model). This is the upper limit of the acceleration.

**Actuator Specifications**

■ Lead and Load Capacity

Model	Motor Output (W)	Lead (mm)	Max. Load Capacity		Rated Thrust (N)	Stroke (mm)
			Horizontal (kg)	Vertical (kg)		
RCACR-SA4C-①-20-10-②-③-④-⑤	20	10	4	1	19.6	50 ~ 400 (50mm increments)
RCACR-SA4C-①-20-5-②-③-④-⑤		5	6	2.5	39.2	
RCACR-SA4C-①-20-2.5-②-③-④-⑤		2.5	8	4.5	78.4	

Legend: ① Encoder ② Stroke ③ Compatible controller ④ Cable length ⑤ Options

■ Stroke, Max. Speed/Suction Volume

Stroke / Lead	50 ~ 400 (50mm increments)		Suction Volume (NL/min)
	Stroke	Max. Speed	
10	665	50	
5	330	30	
2.5	165	15	

(Unit: mm/s)

① Encoder & Stroke List

Stroke (mm)	Standard Price	
	Encoder Type	
	Incremental	Absolute
50	-	-
100	-	-
150	-	-
200	-	-
250	-	-
300	-	-
350	-	-
400	-	-

④ Cable List

Type	Cable Symbol	Standard Price
Standard Type	P (1m)	-
	S (3m)	-
	M (5m)	-
Special Lengths	X06 (6m) ~ X10 (10m)	-
	X11 (11m) ~ X15 (15m)	-
	X16 (16m) ~ X20 (20m)	-
	R01 (1m) ~ R03 (3m)	-
Robot Cable	R04 (4m) ~ R05 (5m)	-
	R06 (6m) ~ R10 (10m)	-
	R11 (11m) ~ R15 (15m)	-
	R16 (16m) ~ R20 (20m)	-
	-	-

\* See page A-39 for cables for maintenance.

⑤ Option List

Name	Option Code	See Page	Standard Price
Brake	B	→ A-25	-
Foot bracket	FT	→ A-29	-
Home sensor	HS	→ A-32	-
Power-saving	LA	→ A-32	-
Reversed-home	NM	→ A-33	-
Slider spacer	SS	→ A-36	-
Intake port mounted on opposite side	VR	→ A-38	-

Actuator Specifications

Item	Description
Drive System	Ball screw ø8mm C10 grade
Positioning Repeatability	±0.02mm
Lost Motion	0.05mm or less
Base	Material: Aluminum (white alumite treated)
Allowable Static Moment	Ma: 6.9N·m Mb: 9.9N·m Mc: 17.0N·m
Allowable Dynamic Moment (*)	Ma: 2.7N·m Mb: 3.9N·m Mc: 6.8N·m
Overhang Load Length	Ma direction: 120mm or less; Mb-Mc direction: 120mm or less
Grease Type	Low dust generation grease (both ball screw and guide)
Cleanliness	Class 10 (0.1µm)
Ambient Operating Temp./Humidity	0~40°C, 85% RH or less (non-condensing)

(\*) Based on a 5,000km service life.

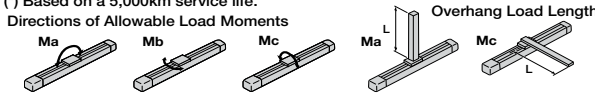

**415** RCACR-SA4C

Dimensions

For Special Orders P. A-9

- \*1 The motor-encoder cable is connected here. See page A-39 for details on cables.
- \*2 When homing, the slider moves to the ME; therefore, please watch for any interference with the surrounding objects.  
ME: Mechanical end SE: Stroke end
- \*3 Reference position for calculating the moment Ma.
- \*4 If the actuator is secured using only the mounting holes provided on the top surface of the base, the base may twist to cause abnormal sliding of the slider, or may produce abnormal noise. Therefore, when using the mounting holes on the top surface of the base, keep the stroke at 200mm or less.

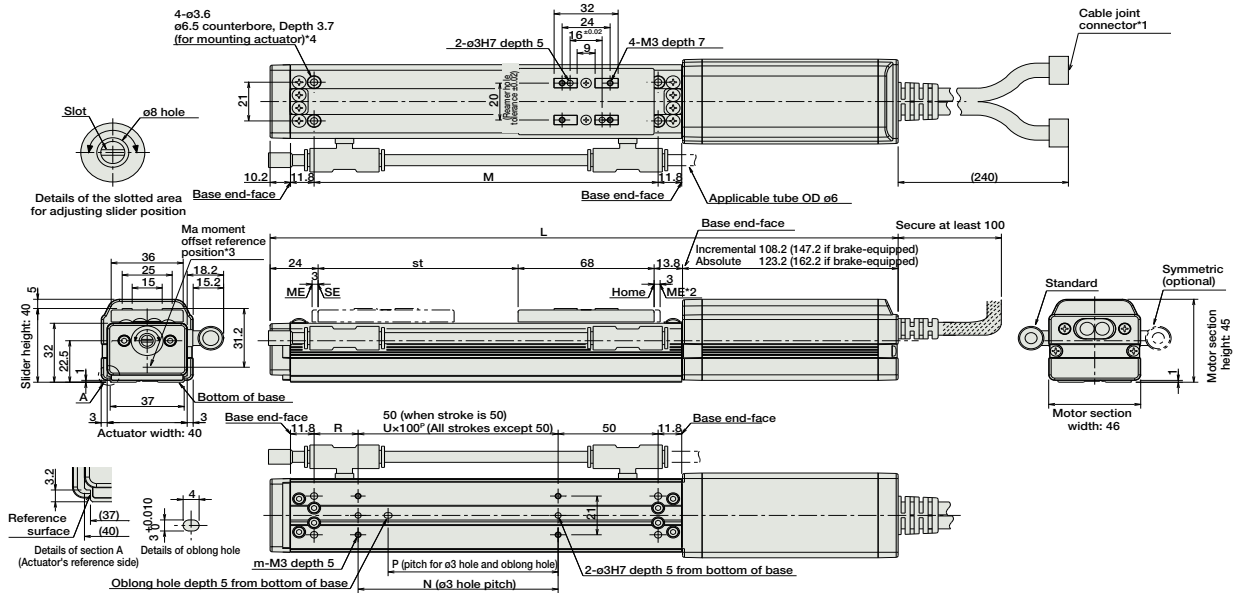

■ Dimensions and Weight by Stroke \* Adding a brake will increase the actuator's weight by 0.3kg.

L	Stroke	Stroke							
		50	100	150	200	250	300	350	400
Incremental	No Brake	264	314	364	414	464	514	564	614
	With Brake	303	353	403	453	503	553	603	653
Absolute	No Brake	279	329	379	429	479	529	579	629
	With Brake	318	368	418	468	518	568	618	668
M		122	172	222	272	322	372	422	472
N		50	100	100	200	200	300	300	400
P		35	85	85	185	185	285	285	385
R		22	22	72	22	72	22	72	22
U		-	1	1	2	2	3	3	4
m		4	4	4	6	6	8	8	10
Weight (kg)		0.7	0.8	0.9	1	1.1	1.2	1.3	1.4

③ Compatible Controllers

The RCACR series actuators can operate with the controllers below. Select the controller according to your usage.

Name	External View	Model	Description	Max. Positioning Points	Input Voltage	Power Supply Capacity	Standard Price	See Page
Solenoid Valve Type		AMEC-C-201②-NP-2-1	Easy-to-use controller, even for beginners	3 points	AC100V	2.4A rated	-	→ P477
		ASEP-C-201②-NP-2-0	Operable with same signal as solenoid valve. Supports both single and double solenoid types. No homing necessary with simple absolute type.					→ P487
Splash-Proof Solenoid Valve Type		ASEP-CW-201②-NP-2-0						
Positioner Type		ACON-C-201②-NP-2-0	Positioning is possible for up to 512 points	512 points	DC24V	(Standard) 1.3A rated 4.4A max.	-	
Safety-Compliant Positioner Type		ACON-CG-201②-NP-2-0						
Pulse Train Input Type (Differential Line Driver)		ACON-PL-201②-NP-2-0	Pulse train input type with differential line driver support	(-)	DC24V	(Power-saving) 1.3A rated 2.5A max.	-	→ P535
Pulse Train Input Type (Open Collector)		ACON-PO-201②-NP-2-0	Pulse train input type with open collector support					
Serial Communication Type		ACON-SE-201②-N-0-0	Dedicated to serial communication	64 points				
Field Network Type		RACON-20②	Dedicated to field network	768 points				→ P503
Program Control Type		ASEL-C-1-20①②-NP-2-0	Programmed operation is possible. Operation is possible on up to 2 axes	1500 points				→ P567

\* This is for the single-axis ASEL.  
 \* ① is a placeholder for the encoder type (I: incremental / A: absolute).  
 \* ② is a placeholder for the code "LA" if the power-saving option is specified.

- Slider Type
- Mini
- Standard
- Controllers Integrated
- Rod Type
- Mini
- Standard
- Controllers Integrated
- Table/Arm /Flat Type
- Mini
- Standard
- Gripper/ Rotary Type
- Linear Servo Type
- Cleanroom Type
- Splash Proof
- Controllers
- PMEC /AMEC
- PSEP /ASEP
- ROBO NET
- ERC2
- PCON
- ACON
- SCON
- PSEL
- ASEL
- SSEL
- XSEL
- Pulse Motor
- Servo Motor (24V)
- Servo Motor (200V)
- Linear Servo Motor