

**3-POSITION CONTROLLER  
FOR ROBO CYLINDER**

**PMEC  
AMEC**

*MEC Controller*





3-position Controller for ROBO Cylinders

**Mechanical Engineer Control (MEC)**

**MEC**

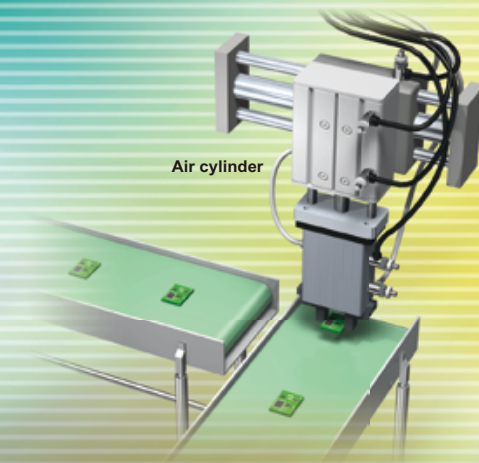

## Affordable and Easy to Use

The MEC allows users, including mechanical engineers, to easily operate IAI's ROBO Cylinders, which are highly recognized in the FA industry for their wide selection of models and superior performance. Just by plugging in the power and setting the speed and acceleration, you can start using the MEC just like an air cylinder, by inputting the Forward and Back signals from the PLC.

### 1. Affordable

The PMEC comes complete with a controller, power supply, acceleration and speed change functions, and all necessary features including a PC connection cable, all at an affordable price.

The price of the MEC and a slider-type ROBO Cylinder combined is comparable to the total cost of a rodless air cylinder, electromagnetic valve, auto switch, and speed controller.

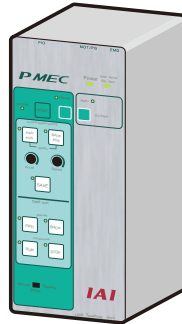

Complete with a controller, power supply, PC connection cable, and all other necessary features such as acceleration and speed change functions, all at an affordable price

### 2. Easy to Use

Just set the desired speed and acceleration using the knobs on the control panel. The continuous operation button lets you quickly verify your movement settings.

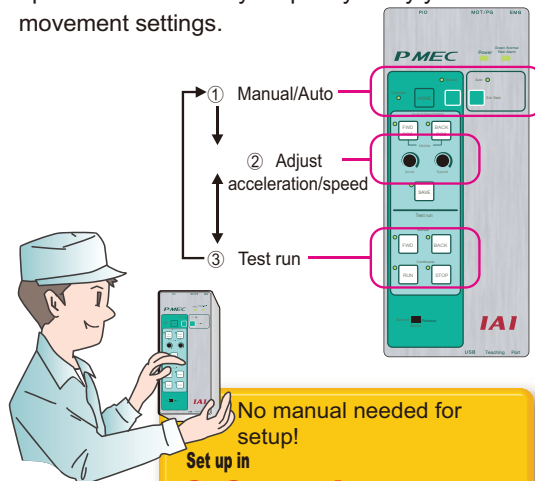

No manual needed for setup!

Set up in

**30 min**

after opening.

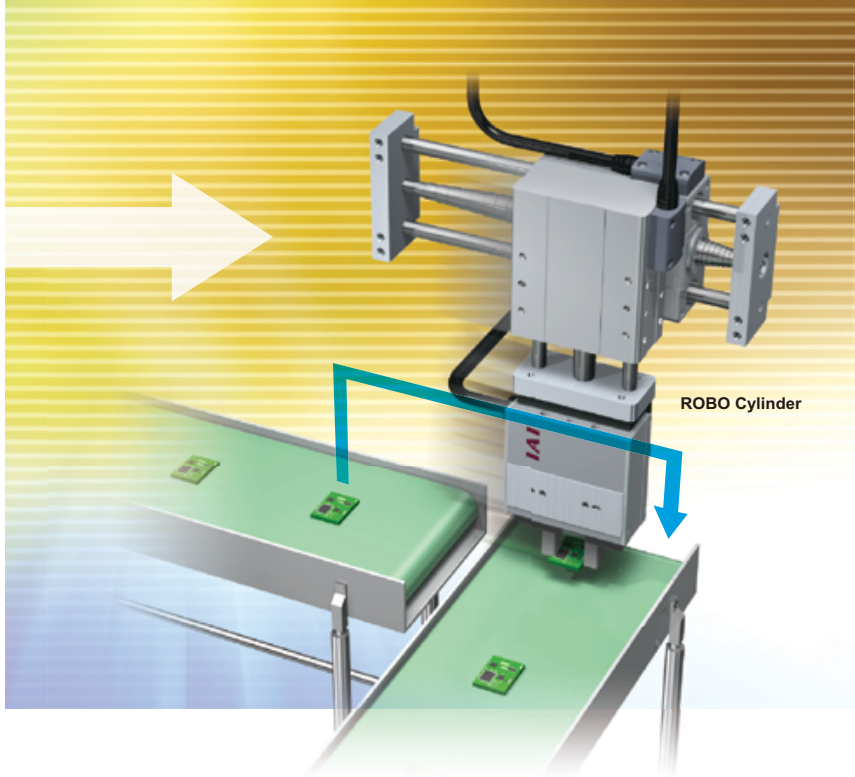

### 3. Versatile

- You can set the speed and acceleration/deceleration to any value within the specifications of each actuator.
- You can control not only 2-position stops, but also 3-position stops when you use the optional MEC-dedicated PC software. In addition, you can set any start and end positions within the stroke.

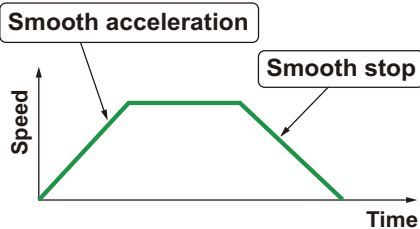

Boosts your productivity with features you can only see in electric cylinders

**Highly Functional**

#### Other Features of MEC/ROBO Cylinders

- **Energy saving**  
Only one-fifth of the power consumption of air cylinders (calculated by IAI).
- **Stable operation even at low speeds**
- **Supports press operation**

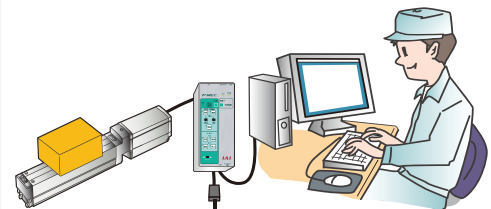

## Anyone can set up and use the MEC, even without any electrical knowledge.

**1** Connect the wiring (see page 17).

**2** Turn the power on.

**3** Verify proper operation.

- 1** Press and hold the MANUAL button for at least 1 second.
- 2** Press the HOME button to prepare for operation.  
(The Complete LED turns on when the home is complete.)
- 3** Check for safety and press the RUN button for a test run.

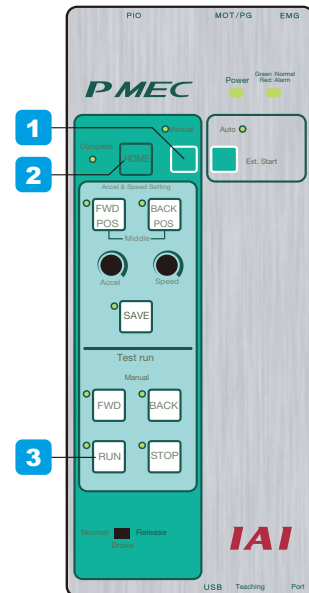

With just these steps, the operation (Continuous Operation) starts.

## 4 To change settings:

Follow the steps below to change the acceleration and speed settings.

You can do these steps even during continuous test operation.

- 4** Press the FWD POS or BACK POS button to select which movement to change.
- 5** Turn the ACCEL and SPEED knobs to the desired values.
- 6** The new settings are applied by pressing the SAVE button.  
(If the MEC is in continuous operation, the new values will take effect on the next operation.)

Use the MEC-dedicated PC software to change the start/end positions, configure intermediate stop settings, or to execute a press operation.

\*Please contact IAI for more information.

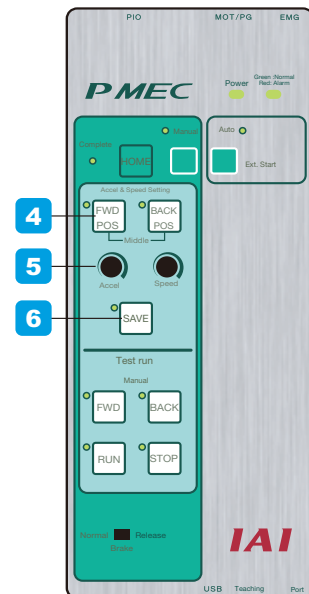



A versatile lineup of ROBO Cylinders, ranging from mini models similar to air cylinders, to rotary and gripper types.

## Actuators Supported by **PMEC**

### Mini ROBO Cylinders

#### RCP3 Mini Slider Type

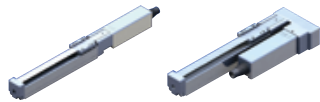

Motor Unit Coupling Type    Motor Reversing Type

#### RCP3 Mini Rod Type

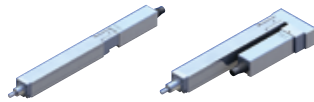

Motor Unit Coupling Type    Motor Reversing Type

#### RCP3 Mini Table Type



Motor Unit Coupling Type    Motor Reversing Type

### ROBO Cylinder

#### RCP3 Series

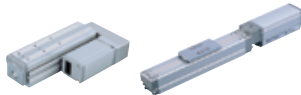

Table Type    Slider Type

#### A pulse motor type that combines high-function and low price



Rotary Type    Gripper Type    Small Gripper    3-Finger Gripper

## Actuators Supported by **AMEC**

### Mini ROBO Cylinders

#### RCA2 Mini Rod Type



Short Length Fixed Nut Type    Short Length Tapped Hole Type    Short Length Single Guide Free Mount Type    Short Length Double Guide Free Mount Type    Short Length Double Guide Slide Unit Type

#### RCA2 Mini Table Type

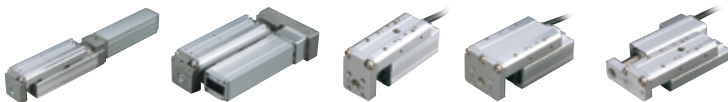

Motor Unit Coupling Type    Motor Reversing Type    Short Length Compact Type    Short Length Wide Type    Short Length Flat Type

#### RCL Mini Linear Servo Type

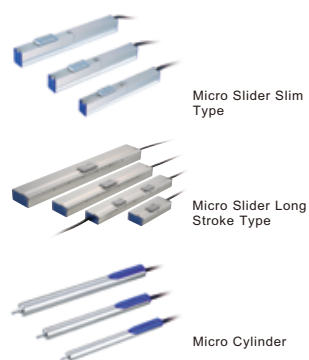

Micro Slider Slim Type

Micro Slider Long Stroke Type

Micro Cylinder

### ROBO Cylinders

#### RCA Series: Servo-type actuators operable at 24V



Coupling Type    Motor Reversing Type    Rod Type with Guide    Slider Type    Motor Reversing Type

#### RCA2 Series

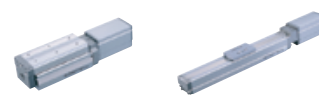
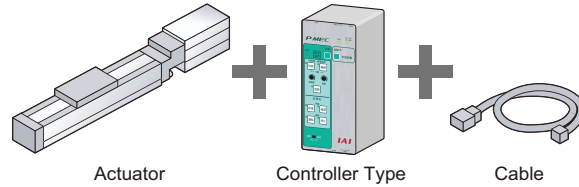

Table Type    Slider Type

# ROBO Cylinder MEC Kits

## What are ROBO Cylinder MEC Kits?

Available for slider and rod types of electric actuators, the ROBO cylinder MEC kit is a set of IAI's most recommended equipment that meets specific speed and load capacity requirements. The MEC kit is a good option if you are not sure which model to choose from the wide range of selections. There are many other types of ROBO Cylinders besides those that are available in the MEC kit. For details, refer to the ROBO Cylinder General Catalog.



Actuator

Controller Type

Cable

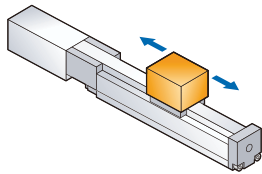

### MEC Slider Kit (Horizontal Type)

This kit is suitable for horizontal transport and positioning of the workpieces.

pattern <b>A</b> Horizontal Load Capacity Less than 5 kg		
Low speed	Medium speed	High speed
100mm/s	200mm/s	400mm/s

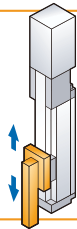

### MEC Slider Kit (Vertical Type)

This kit is suitable for vertical transport and positioning of the workpieces.

pattern <b>D</b> Vertical load capacity Less than 1 kg		
Low speed	Medium speed	High speed
50mm/s	100mm/s	250mm/s

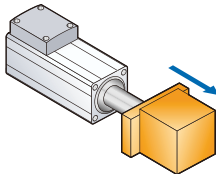

### MEC Rod Kit (Horizontal Type)

This kit is suitable for clamping and pushing the workpieces.

pattern <b>A</b> Horizontal Load Capacity Less than 10 kg		
Low speed	Medium speed	High speed
100mm/s	300mm/s	400mm/s

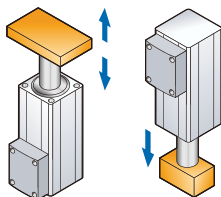

### MEC Rod Kit (Vertical Type)

This kit is suitable for raising/lowering the workpieces and stackers, or for press-fitting and caulking the workpieces.

pattern <b>E</b> Vertical load capacity Less than 5 kg		
Low speed	Medium speed	High speed
50mm/s	100mm/s	150mm/s

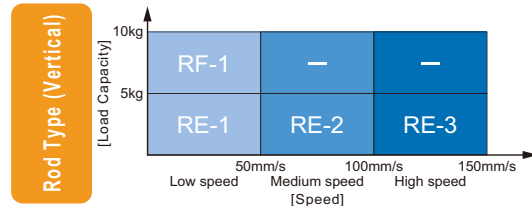
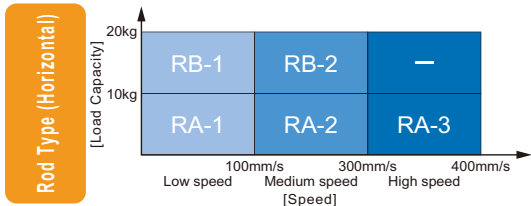
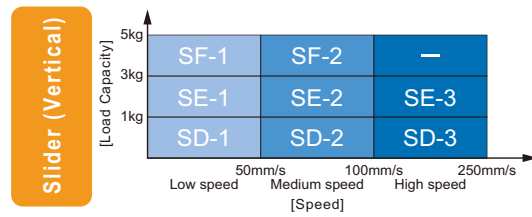
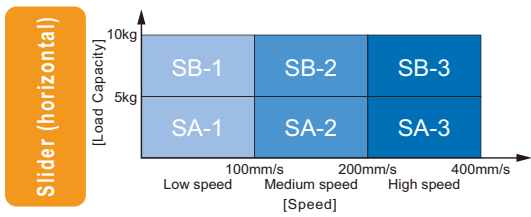

**pattern B** Horizontal Load Capacity  
Less than 10 kg

Low speed	Medium speed	High speed
100mm/s	200mm/s	400mm/s



P7

**pattern E** Vertical load capacity  
Less than 3 kg

Low speed	Medium speed	High speed
50mm/s	100mm/s	250mm/s

**pattern F** Vertical load capacity  
Less than 5 kg

Low speed	Medium speed
50mm/s	100mm/s



P9

**pattern B** Horizontal Load Capacity  
Less than 20 kg

Low speed	Medium speed
100mm/s	300mm/s



P11

**pattern F** Vertical load capacity  
Less than 10 kg

Low speed
50mm/s





P13



# ROBO Cylinder MEC Kits

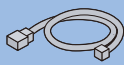

**Selection procedure** Select the MEC kit that is right for you.

- 1 Select **pattern A** if each workpiece transported weighs less than 5kg, or **pattern B** if less than 10kg.
- 2 Once you have decided on the pattern, select the kit according to the desired speed and stroke.
- 3 Place your order by the kit number.

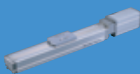
## pattern A Horizontal load capacity **Less than 5kg**

Speed	Kit Configuration		Stroke	Kit Number	
Low Speed (100mm/sec)	Actuator		RCP3-SA4C-I-35P -10- <input type="text"/> -P3-M <b>→P24</b>	50mm	SA-1-050
				100mm	SA-1-100
				150mm	SA-1-150
	Controller Type		PMEC-C-35PI-NP-2-1	200mm	SA-1-200
				250mm	SA-1-250
				300mm	SA-1-300
				350mm	SA-1-350
				400mm	SA-1-400
	Cable		5m cable included	450mm	SA-1-450
				500mm	SA-1-500

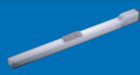
Medium Speed (200mm/sec)	Actuator		RCP3-SA4C-I-35P -10- <input type="text"/> -P3-M <b>→P24</b>	50mm	SA-2-050
				100mm	SA-2-100
				150mm	SA-2-150
	Controller Type		PMEC-C-35PI-NP-2-1	200mm	SA-2-200
				250mm	SA-2-250
				300mm	SA-2-300
				350mm	SA-2-350
				400mm	SA-2-400
	Cable		5m cable included	450mm	SA-2-450
				500mm	SA-2-500

High Speed* (400 mm/sec)	Actuator		RCP2-SA5C-I-42P -12- <input type="text"/> -P3-M <b>→P26</b>	50mm	SA-3-050
				100mm	SA-3-100
				150mm	SA-3-150
	Controller Type		PMEC-C-42PI-NP-2-1	200mm	SA-3-200
				250mm	SA-3-250
				300mm	SA-3-300
				350mm	SA-3-350
				400mm	SA-3-400
	Cable		5m cable included	450mm	SA-3-450
				500mm	SA-3-500
				550mm	SA-3-550
				600mm	SA-3-600
				650mm	SA-3-650
				700mm	SA-3-700
				750mm	SA-3-750
				800mm	SA-3-800

\* This speed cannot be attained if the stroke is 750 mm or more.

① A placeholder for the value of the desired stroke.

Example: "50" for 50mm







## MEC Slider Kit (Horizontal Type)

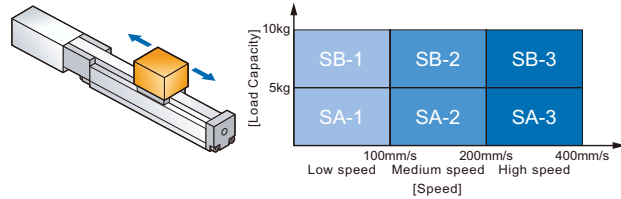

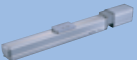

### Ordering Example:

If load capacity = 5kg, speed = medium speed (200mm/sec), and stroke = 300mm, the kit number to order is **SA-2-300**.

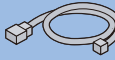

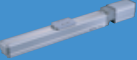



## pattern B Horizontal load capacity Less than 10kg

Speed	Kit Configuration		Stroke	Kit Number	
Low Speed (100mm/sec)	Actuator		RCP3-SA5C-I-42P	50mm	SB-1-050
			-6-  -P3-M 	100mm	SB-1-100
	Controller Type		PMEC-C-42PI-NP-2-1	150mm	SB-1-150
				200mm	SB-1-200
				250mm	SB-1-250
				300mm	SB-1-300
				350mm	SB-1-350
				400mm	SB-1-400
				450mm	SB-1-450
				500mm	SB-1-500
Cable		5m cable included	550mm	SB-1-550	
			600mm	SB-1-600	
			650mm	SB-1-650	
			700mm	SB-1-700	
			750mm	SB-1-750	
			800mm	SB-1-800	

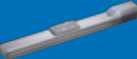
Medium Speed* (200mm/sec)	Actuator		RCP3-SA5C-I-42P	50mm	SB-2-050
			-6-  -P3-M 	100mm	SB-2-100
	Controller Type		PMEC-C-42PI-NP-2-1	150mm	SB-2-150
				200mm	SB-2-200
				250mm	SB-2-250
				300mm	SB-2-300
				350mm	SB-2-350
				400mm	SB-2-400
				450mm	SB-2-450
				500mm	SB-2-500
Cable		5m cable included	550mm	SB-2-550	
			600mm	SB-2-600	
			650mm	SB-2-650	
			700mm	SB-2-700	
			750mm	SB-2-750	
			800mm	SB-2-800	

\* This speed cannot be attained if the stroke is 700 mm or more.

High Speed* (400 mm/sec)	Actuator		RCP2-SA7C-I-56P	50mm	SB-3-050
			-16-  -P3-M 	100mm	SB-3-100
	Controller Type		PMEC-C-56PI-NP-2-1	150mm	SB-3-150
				200mm	SB-3-200
				250mm	SB-3-250
				300mm	SB-3-300
				350mm	SB-3-350
				400mm	SB-3-400
				450mm	SB-3-450
				500mm	SB-3-500
Cable		5m cable included	550mm	SB-3-550	
			600mm	SB-3-600	
			650mm	SB-3-650	
			700mm	SB-3-700	
			750mm	SB-3-750	
			800mm	SB-3-800	

# ROBO Cylinder MEC Kits



**Selection procedure** Select the MEC kits that is right for you.

1 Select **pattern D** if each workpiece transported weighs less than 1kg, **pattern E** if less than 3kg, or **pattern F** if less than 5kg.



2 Once you have decided on the pattern, select the kit according to the desired speed and stroke.

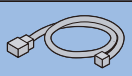

3 Place your order by the kit number.



## Vertical Load Capacity pattern **D** Less than 1kg

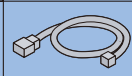

Speed	Kit Configuration		Stroke	Kit Number
Low Speed (50mm/sec)	Actuator	 RCP3-SA3C-I-28P-4- <sup>ⓐ</sup> -P3-M-B →P23	50mm	SD-1-050
			100mm	SD-1-100
			150mm	SD-1-150
	Controller Type	 PMEC-C-28PI-NP-2-1	200mm	SD-1-200
			250mm	SD-1-250
			300mm	SD-1-300
Cable	 5m cable included			

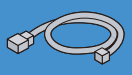

## Vertical Load Capacity pattern **E** Less than 3kg

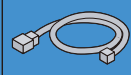
Speed	Kit Configuration		Stroke	Kit Number
Low Speed (50mm/sec)	Actuator	 RCP3-SA4C-I-35P-5- <sup>ⓐ</sup> -P3-M-B →P24	50mm	SD-2-050
			100mm	SD-2-100
			150mm	SD-2-150
	Controller Type	 PMEC-C-35PI-NP-2-1	200mm	SD-2-200
			250mm	SD-2-250
			300mm	SD-2-300
Cable	 5m cable included			

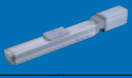
Speed	Kit Configuration		Stroke	Kit Number
Medium Speed (100mm/sec)	Actuator	 RCP3-SA3C-I-28P-4- <sup>ⓐ</sup> -P3-M-B →P23	50mm	SD-2-050
			100mm	SD-2-100
			150mm	SD-2-150
	Controller Type	 PMEC-C-28PI-NP-2-1	200mm	SD-2-200
			250mm	SD-2-250
			300mm	SD-2-300
Cable	 5m cable included			

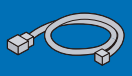
Speed	Kit Configuration		Stroke	Kit Number
Medium Speed (100mm/sec)	Actuator	 RCP3-SA4C-I-35P-5- <sup>ⓐ</sup> -P3-M-B →P24	50mm	SD-3-050
			100mm	SD-3-100
			150mm	SD-3-150
	Controller Type	 PMEC-C-35PI-NP-2-1	200mm	SD-3-200
			250mm	SD-3-250
			300mm	SD-3-300
Cable	 5m cable included			

Speed	Kit Configuration		Stroke	Kit Number
High Speed (250mm/sec)	Actuator	 RCP3-SA4C-I-35P-5- <sup>ⓐ</sup> -P3-M-B →P24	50mm	SD-3-050
			100mm	SD-3-100
			150mm	SD-3-150
	Controller Type	 PMEC-C-35PI-NP-2-1	200mm	SD-3-200
			250mm	SD-3-250
			300mm	SD-3-300
	Cable	 5m cable included	350mm	SD-3-350
			400mm	SD-3-400
			450mm	SD-3-450
		500mm	SD-3-500	

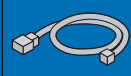
Speed	Kit Configuration		Stroke	Kit Number
High Speed* (250 mm/sec)	Actuator	 RCP2-SA5C-I-42P-6- <sup>ⓐ</sup> -P3-M-BL →P26	50mm	SD-3-050
			100mm	SD-3-100
			150mm	SD-3-150
	Controller Type	 PMEC-C-42PI-NP-2-1	200mm	SD-3-200
			250mm	SD-3-250
			300mm	SD-3-300
Cable	 5m cable included			

\* This speed cannot be attained if the stroke is 650 mm or more.

1 A placeholder for the value of the desired stroke.  
Example: "50" for 50mm

## MEC Slider Kit (Vertical Type)

### Ordering Example:

If load capacity = less than 3kg,  
speed = low speed (50mm/sec),  
and stroke = 100mm, the bundle  
package to order is **SE-1-100**.

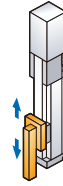

[Load Capacity]	5kg	SF-1	SF-2	—
	3kg	SE-1	SE-2	SE-3
	1kg	SD-1	SD-2	SD-3
		50mm/s	100mm/s	250mm/s
		Low Speed	Medium Speed	High Speed
		[Speed]		

### Vertical Load Capacity pattern **F** Less than 5kg

Stroke	Kit Number	Speed	Kit Configuration		Stroke	Kit Number
50mm	SE-1-050	Low Speed (50mm/sec)	Actuator	RCP3-SA5C-I-42P -3-① -P3-M-B →P25	50mm	SF-1-050
100mm	SE-1-100				100mm	SF-1-100
150mm	SE-1-150		Controller Type	PMEC-C-42PI-NP-2-1	150mm	SF-1-150
200mm	SE-1-200				200mm	SF-1-200
250mm	SE-1-250		Cable	5m cable included	250mm	SF-1-250
300mm	SE-1-300				300mm	SF-1-300
350mm	SE-1-350				350mm	SF-1-350
400mm	SE-1-400				400mm	SF-1-400
450mm	SE-1-450				450mm	SF-1-450
500mm	SE-1-500				500mm	SF-1-500
550mm	SE-1-550	550mm			SF-1-550	
600mm	SE-1-600	600mm			SF-1-600	
650mm	SE-1-650	650mm	SF-1-650			
700mm	SE-1-700	700mm	SF-1-700			
750mm	SE-1-750	750mm	SF-1-750			
800mm	SE-1-800	800mm	SF-1-800			
50mm	SE-2-050	Medium Speed* (100mm/sec)	Actuator	RCP3-SA5C-I-42P -3-① -P3-M-B →P25	50mm	SF-2-050
100mm	SE-2-100				100mm	SF-2-100
150mm	SE-2-150		Controller Type	PMEC-C-42PI-NP-2-1	150mm	SF-2-150
200mm	SE-2-200				200mm	SF-2-200
250mm	SE-2-250		Cable	5m cable included	250mm	SF-2-250
300mm	SE-2-300				300mm	SF-2-300
350mm	SE-2-350				350mm	SF-2-350
400mm	SE-2-400				400mm	SF-2-400
450mm	SE-2-450				450mm	SF-2-450
500mm	SE-2-500				500mm	SF-2-500
550mm	SE-2-550	550mm			SF-2-550	
600mm	SE-2-600	600mm			SF-2-600	
650mm	SE-2-650	650mm	SF-2-650			
700mm	SE-2-700	700mm	SF-2-700			
750mm	SE-2-750	750mm	SF-2-750			
800mm	SA-3-800	800mm	SF-2-800			

\* This speed cannot be attained if the stroke is 750 mm or more.

# ROBO Cylinder MEC Kits









**Selection procedure** Select the MEC kit that is right for you.

1 Select **pattern A** if each workpiece transported weighs less than 10kg, or **pattern B** if less than 20kg.

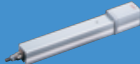
2 Once you have decided on the pattern, select the kit according to the desired speed and stroke.

3 Place your order by the kit number.

## pattern A Horizontal Load Capacity **Less than 10 kg**

Speed	Kit Configuration			Stroke	Kit Number
Low Speed* (100mm/sec)	Actuator		RCP2-RA4C-I-42P -2.5- <sup>①</sup> -P3-M →P28	50mm	RA-1-050
				100mm	RA-1-100
				150mm	RA-1-150
				200mm	RA-1-200
	Controller Type		PMEC-C-42PI-NP-2-1	250mm	RA-1-250
				300mm	RA-1-300
	Cable		5m cable included		
Medium Speed (300mm/sec)	Actuator		RCP2-RA4C-I-42P -10- <sup>①</sup> -P3-M →P28	50mm	RA-2-050
				100mm	RA-2-100
				150mm	RA-2-150
				200mm	RA-2-200
	Controller Type		PMEC-C-42PI-NP-2-1	250mm	RA-2-250
				300mm	RA-2-300
	Cable		5m cable included		
High Speed* (400mm/sec)	Actuator		RCP2-RA4C-I-42P -10- <sup>①</sup> -P3-M →P28	50mm	RA-3-050
				100mm	RA-3-100
				150mm	RA-3-150
				200mm	RA-3-200
	Controller Type		PMEC-C-42PI-NP-2-1	250mm	RA-3-250
				300mm	RA-3-300
	Cable		5m cable included		

\* This speed cannot be attained if the stroke is 300mm or more.

① A placeholder for the value of the desired stroke.

Example: "50" for 50mm









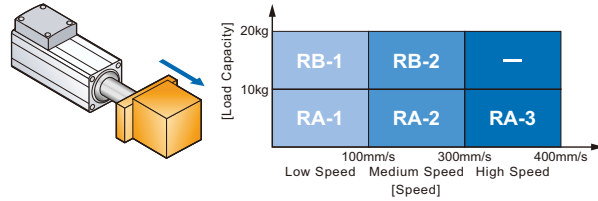

## MEC Rod Kit (Horizontal Type)

### Ordering Example:

If load capacity = less than 10kg, speed = high speed (400mm/sec), and stroke = 150mm, the bundle package number to order is **RA-3-150**.



## pattern B Horizontal Load Capacity Less than 20 kg

Speed	Kit Configuration		Stroke	Kit Number
Low Speed* (100mm/sec)	Actuator	 RCP2-RA4C-I-42P -2.5-  -P3-M →P28	50mm	RB-1-050
	Controller Type	 PMEC-C-42PI-NP-2-1	100mm	RB-1-100
	Cable	 5m cable included	150mm	RB-1-150
			200mm	RB-1-200
Medium Speed (300mm/sec)	Actuator	 RCP2-RA4C-I-42P -10-  -P3-M →P28	250mm	RB-1-250
	Controller Type	 PMEC-C-42PI-NP-2-1	300mm	RB-1-300
	Cable	 5m cable included	50mm	RB-2-050
			100mm	RB-2-100
			150mm	RB-2-150
			200mm	RB-2-200
			250mm	RB-2-250
			300mm	RB-2-300

\* This speed cannot be attained if the stroke is 300mm or more.

# ROBO Cylinder MEC Kits









**Selection procedure** Select the MEC kit that is right for you.

1 Select **pattern E** if each workpiece transported weighs less than 5kg, or **pattern F** if less than 10kg.

2 Once you have decided on the pattern, select the kit according to the desired speed and stroke.

3 Place your order by the kit number.

## pattern E Vertical Load Capacity **Less than 5 kg**

Speed	Kit Configuration		Stroke	Kit Number
Low Speed (50mm/sec)	Actuator	 RCP2-RA4C-I-42P -2.5- <sup>①</sup> -P3-M-B →P28	50mm	RE-1-050
	Controller Type	 PMEC-C-42PI-NP-2-1	100mm	RE-1-100
	Cable	 5m cable included	150mm	RE-1-150
			200mm	RE-1-200
			250mm	RE-1-250
			300mm	RE-1-300
Medium Speed (100mm/sec)	Actuator	 RCP2-RA4C-I-42P -5- <sup>①</sup> -P3-M-B →P28	50mm	RE-2-050
	Controller Type	 PMEC-C-42PI-NP-2-1	100mm	RE-2-100
	Cable	 5m cable included	150mm	RE-2-150
			200mm	RE-2-200
			250mm	RE-2-250
			300mm	RE-2-300
High Speed (150mm/sec)	Actuator	 RCP2-RA4C-I-42P -5- <sup>①</sup> -P3-M-B →P28	50mm	RE-3-050
	Controller Type	 PMEC-C-42PI-NP-2-1	100mm	RE-3-100
	Cable	 5m cable included	150mm	RE-3-150
			200mm	RE-3-200
			250mm	RE-3-250
			300mm	RE-3-300

① A placeholder for the value of the desired stroke.  
Example: "50" for 50mm



### MEC Rod Kit (Vertical Type)

**Ordering Example:**

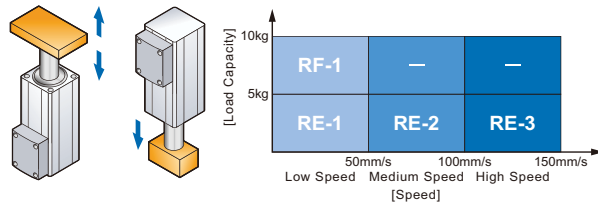
If load capacity = less than 5kg, speed = medium speed (200mm/sec), and stroke = 50mm, the bundle package number to order is **RE-2-050**.



**pattern F** Vertical Load Capacity **Less than 10 kg**

Speed	Kit Configuration		Stroke	Kit Number
Low Speed (100mm/sec)	Actuator	 RCP2-RA4C-I-42P -2.5-①-P3-M-B →P28	50mm	RF-1-050
	Controller Type	 PMEC-C-42PI-NP-2-1	100mm	RF-1-100
	Cable	 5m cable included	150mm	RF-1-150
			200mm	RF-1-200
			250mm	RF-1-250
			300mm	RF-1-300

**PMEC** 3-position 100/200VAC  
Controller for RCP2/RCP3

**AMEC** 3-position 100VAC  
Controller for RCA/RCA2/RCL



**MEC** (Mechanical Engineer Control ) **3-position Controller for ROBO Cylinders**

**Features**

**1 Low Price**

The PMEAC comes complete with a controller, power supply, acceleration and speed change functions, and all necessary features including a PC connection cable, all at an affordable price. In addition, a MEC-dedicated PC software is available as an option.

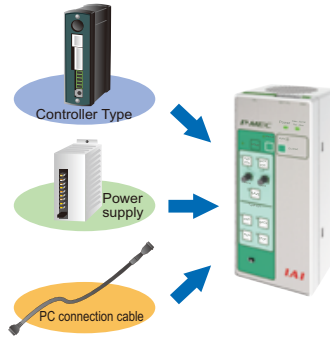

**2 Easy to Use**

Even first-time users can set up the MEC without a manual. The acceleration and speed settings can be changed with the knobs on the controller.

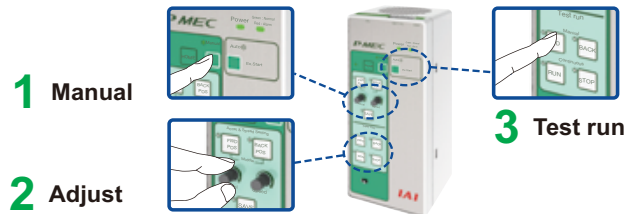

**3 Easy to Replace Air Cylinders**

The very same signals that drive the air cylinders can drive ROBO Cylinders. Hence you can continue using your current PLC programs without any modification.

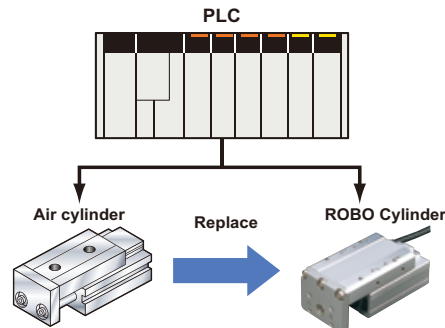

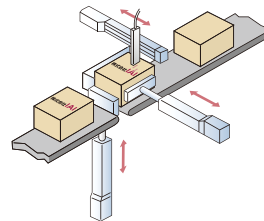

**4 Supports Press/Intermediate Stop Operations**

ROBO Cylinders support press operations similar to air cylinders. In addition, the MEC-dedicated PC software allows you to configure intermediate stop at any position between the home position and stroke end position.





## List of Models

Series	PMEC	AMEC
Appearance		
Supported Actuators	RCP2/RCP3	
Power Supply Voltage	100V	100V
Accessories	AC power supply cable (2m) USB cable (3m) I/O cable (2m) I/O connector EMG connector Standard mounting bracket	

## Model

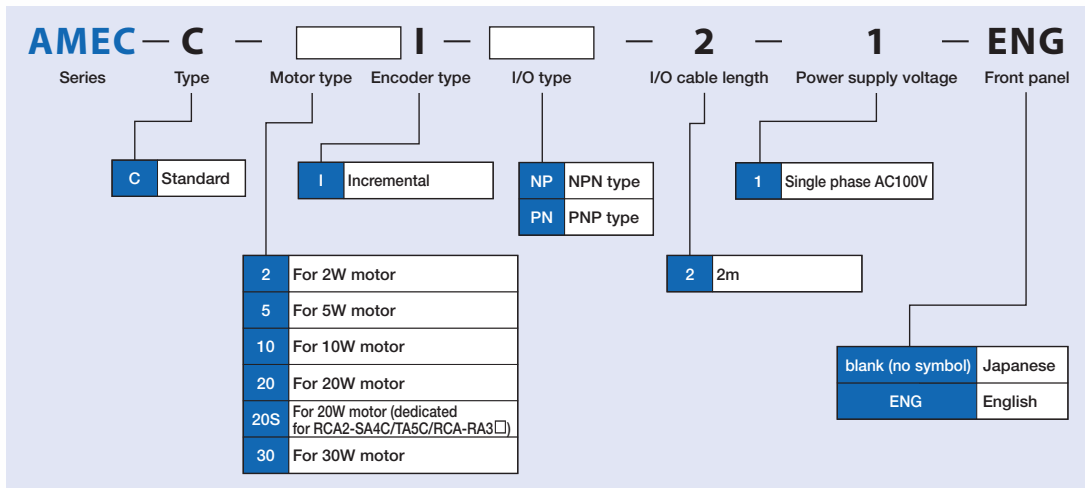
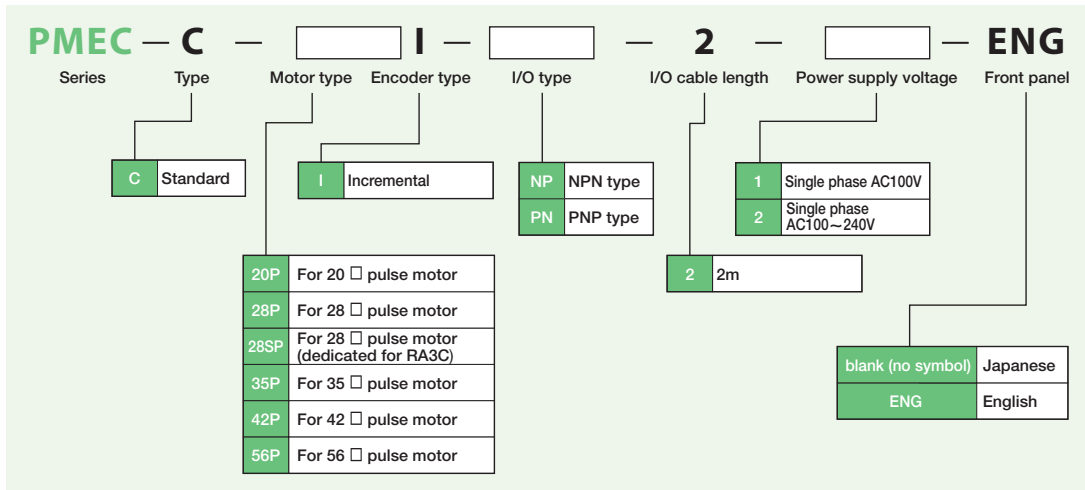

System Configuration

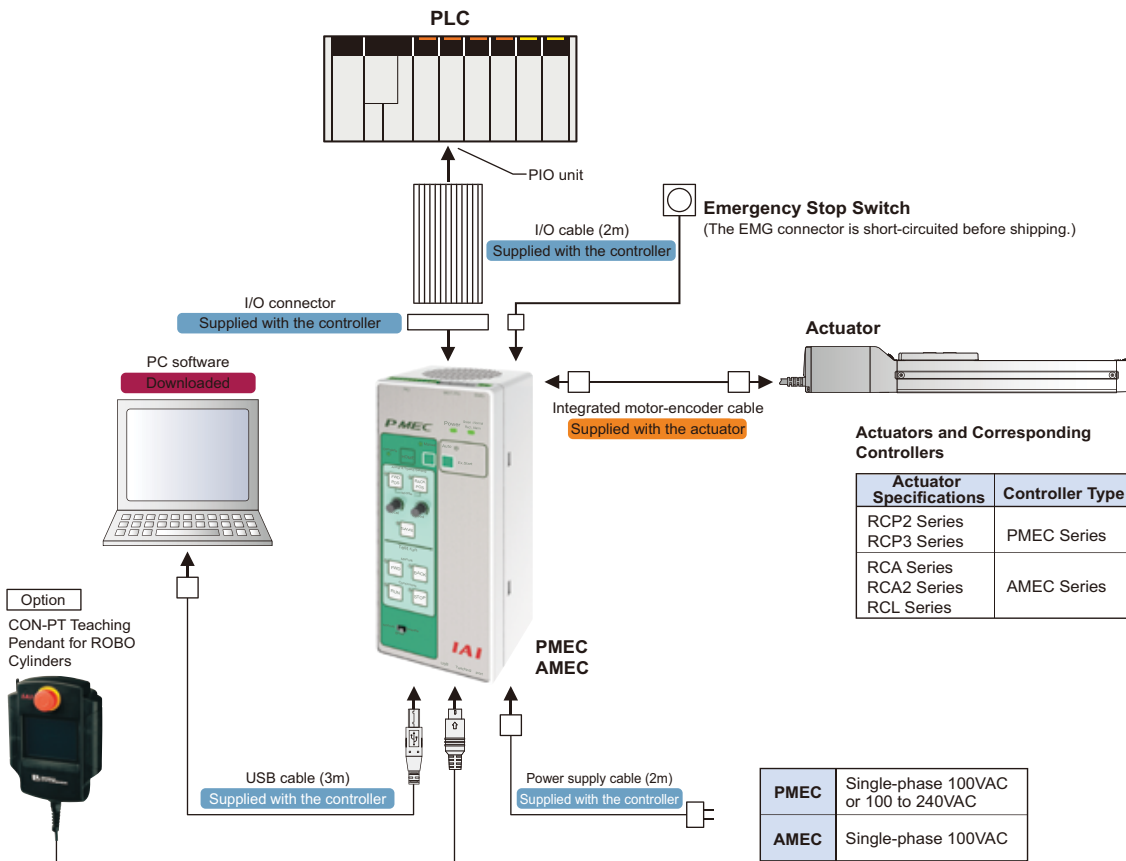

I/O Signal Table

Operating pattern			2-Position Stop	3-Position Stop
Pin No.	Wire Color	Signal Type	Signal Name	Signal Name
1	Brown	PIO power supply	24V	24V
2	Red		0V	0V
3	Orange	Input	ST0 (Solenoid A: ON moves to the end position, and OFF moves to the home position.)	ST0 (Solenoid A: MOVE signal 1)
4	Yellow		-	ST1 (Solenoid B: MOVE signal 2)
5	Green		RES (Alarm reset)	RES (Alarm reset)
6	Blue		-	-
7	Purple	Output	LS0 (Home position detected)/PE0 (Home positioning complete) <sup>*1</sup>	LS0 (Home position detected)/PE0 (Home positioning complete) <sup>*1</sup>
8	Gray		LS1 (End position detected)/PE1 (End positioning complete) <sup>*1</sup>	LS1 (End position detected)/PE1 (End positioning complete) <sup>*1</sup>
9	White		HEND (home return complete)	LS2 (Intermediate point detected)/PE2 (Intermediate positioning complete) <sup>*1</sup>
10	Black		* ALM (alarm) <sup>*2</sup>	* ALM (alarm) <sup>*2</sup>

\* 1: Signals PE0 through PE2 will be output if the press function was enabled in the initial setting. Otherwise, LS0 through LS2 will be output.  
 \* 2: The ALM signal is normally ON, and turns OFF when an alarm occurs.

MEC PC Software

Please contact IAI technical support for more information.

[www.intelligentactuator.com](http://www.intelligentactuator.com)

## Operation Patterns

### PIO Pattern (2-point travel)

This movement pattern consists of a movement between two positions (front and rear positions). You can easily set the front and rear positions by entering the numbers into the controller using the MEC PC software or the optional Teaching Pendant. There are two movements in this pattern. In the "Positioning" movement, the rod and the slider move to the specified position, and in the "Press" movement, the rod is pressed onto the work piece.

#### Pointing

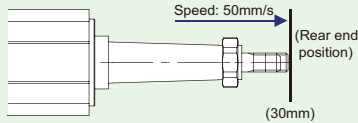

#### Input Signal

ST0	Solenoid A	ON
-----	------------	----

When ST0 is turned ON, the rod moves to the rear end position (at a coordinate of 30mm) at a speed of 50mm/s.

#### Rear end position data

Position	30mm
Speed	50mm/s
Pressing Force	—
Width	—

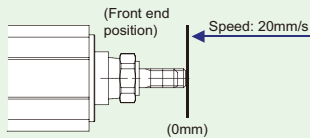

#### Input Signal

ST0	Solenoid A	OFF
-----	------------	-----

When ST0 is turned OFF, the rod returns to the front end position (at a position of 0mm) at a speed of 20mm/s.

#### Front end position data

Position	0mm
Speed	20mm/s
Pressing Force	—
Width	—

### PIO Pattern (2-point travel)

This pattern of operation consists of a movement between two positions (Front end and rear end positions) for a "press operation", in which the rod is pressed onto the workpiece.

#### Press Operation

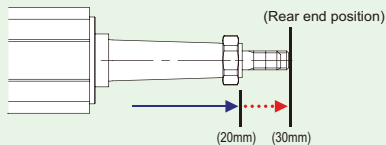

#### Input Signal

ST0	Solenoid A	ON
-----	------------	----

When Input 0 is turned on, the rod moves up to the 20mm position at a speed of 80mm/s. Then the pressing will take place from the 20mm position to the 30mm position at low speed.

#### Rear end position data

Position	30mm
Speed	80mm/s
Pressing Force	50%
Width	10mm

\* The press operation is enabled when there is a numerical value specified for the pressing force in the position data of the controller. (If no numeric value is specified for the pressing force, it will default to positioning operation.)

### PIO Pattern (3-point travel)

This pattern of operation consists of a movement between three positions (front end, intermediate, and rear end positions). Movement positions are switched with a combination of two signals, i.e., ST0 and ST1.

#### Positioning

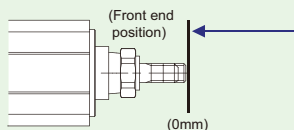

#### Input Signal

ST0	Solenoid A	ON
ST1	Solenoid B	OFF

If only ST0 is turned ON, the rod moves to the front end position at the acceleration or speed that you specified.

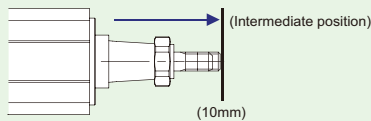

#### Input Signal

ST0	Solenoid A	ON*
ST1	Solenoid B	ON*

If both ST0 and ST1 are turned ON, the rod moves to the intermediate position at the acceleration or speed that you specified. Turning both signals OFF will cause the rod to stop in place.

\* You can also configure the initial settings so that the rod will move to the intermediate position with both signals turned ON, and stop in place with both signals turned ON.

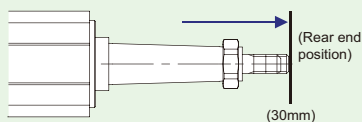

#### Input Signal

ST0	Solenoid A	OFF
ST1	Solenoid B	ON

If only ST1 is turned ON, the rod moves to the rear end position at the acceleration or speed that you specified.

## Specifications

Item	Specification		
Controller Type	PMEC		AMEC
Actuator Specifications	RCP2/RCP3 Series Actuator		RCA/RCA2/RCL Series Actuator
Number of control axes	Single axis		
Operating mode	Positioner type		
Number of positions	2/3		
Backup memory	EEPROM		
I/O connector	10-pin terminal block		
I/O points	4 input points/4 output points		
I/O power supply	External power supply at 24 VDC $\pm$ 10%		
Serial communication	RS485: 1 ch/USB: 1 ch		
Position detection method	Incremental encoder		
Power Supply Voltage	AC100V $\pm$ 10%	AC100V-240V $\pm$ 10%	AC100V $\pm$ 10%
Rated current	1.3A	0.67A(AC100V)/0.36A(AC200V)	2.4A
Inrush current	30A	15A(AC100V)/30A(AC200V)	15A
Leak current	0.5mA or less	0.40mA max(AC100V) 0.75mA max(AC200V)	0.50mA or less
Dielectric strength	DC500V 1M $\Omega$		
Vibration resistance	Single amplitudes of 0.035mm (continuous) and 0.075mm (intermittent) at 10 to 57Hz 4.9 m/s <sup>2</sup> (continuous) and 9.8 m/s <sup>2</sup> (intermittent) at 57 to 150 Hz. Vibration resistance in X, Y, and Z directions		
Ambient operating temperature	0-40°C		
Ambient operating humidity	10% to 85% RH (no condensation)		
Ambient operating atmosphere	No corrosive gas		
Enclosure rating	IP20		
Weight	395g	410g	505g

## Dimensions

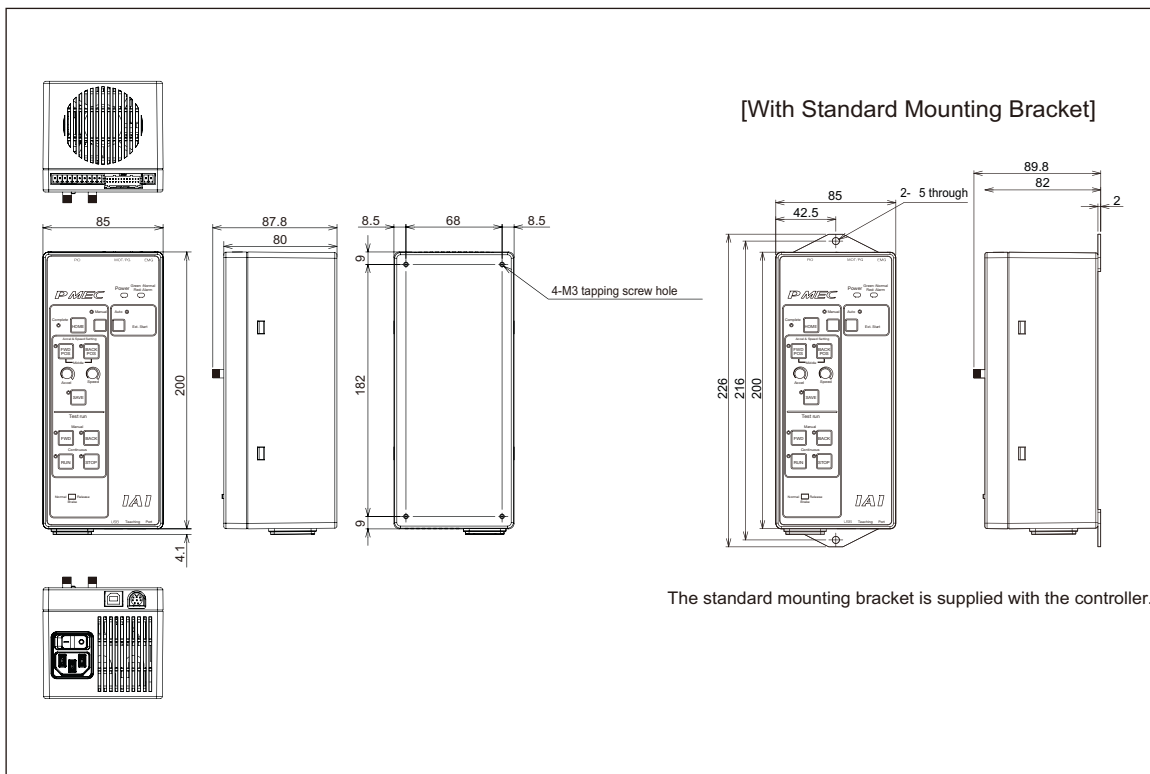



## Part Names and Functions

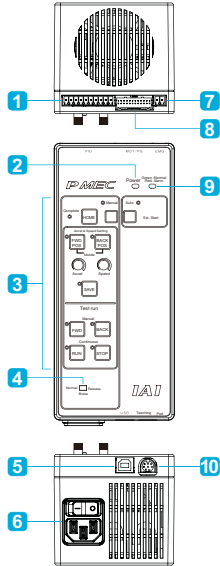

- 1** PIO connector ..... Used for I/O connection with an external controller, such as a PLC.
- 2** Power LED ..... Lit green when the power is turned on.
- 3** Control Panel ..... See below.
- 4** Brake switch
 

Release	Used to release the brake of the actuator.
Normal	Used to control the brake of the actuator.
- 5** USB connector ..... Used for USB connection with the computer when using the MEC PC software.
- 6** AC inlet ..... Used for inserting the power supply cable.
- 7** EMG connector ..... Used to connect to the emergency stop button. Short-circuit the connector if no emergency stop button is used.
- 8** MOT/PG connector ..... Used for inserting the cable to connect with the actuator.
- 9** Status LED
 

RUN (green)	Indicates the status of the servo. On: Servo ON; Off: Servo OFF (energy-saving mode) Flashing (1Hz): Auto servo OFF
ALM (red) EMG (red)	The LED flashes if an alarm is turned ON or if the controller has come to an emergency stop.
- 10** SIO connector ..... Used to connect to the CON-PT or SEP-PT Teaching Pendant.

## Control Panel

### HOME button

At the start of operation, first home and verify the position at 0mm.

### MANUAL button

Press this button to set the acceleration and/or speed, or to start a test run.  
(Press for at least one second.)

### AUTO button

Press this button for at least one second to operate the controller with commands from the MEC PC software or a PLC. (Press for at least one second.)

### Acceleration and Maximum Speed Settings

Configure the movement of the actuator.

#### FWD POS / BACK POS button

Use these buttons to switch to the movement you want to configure:  
**FWD POS:** Movement toward the end position.  
**BACK POS:** Movement toward the home position  
**MIDDLE:** Movement toward the intermediate position.  
 (Enabled in the MEC PC software and switched on by pressing "FWD POS" and "BACK POS" buttons simultaneously. Pressing these buttons is disabled for 2-position travel.)

#### Acceleration / Speed knobs

Use these knobs to set the speed/acceleration between 1 to 100% of the maximum speed and rated acceleration/deceleration.

\* The minimum speed may be less than 1% in some cases.

#### SAVE button

Use this button to save the speed and acceleration settings.

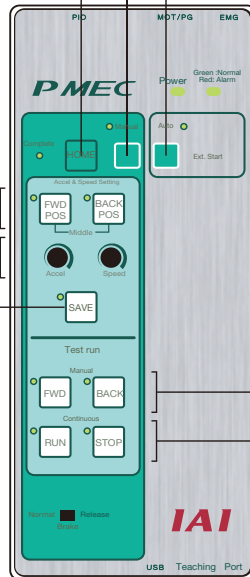

### Test run

Physically moves the actuator so you can verify the registered movement.

#### FWD button

Moves the actuator toward the rear end position. In a 2-position travel, the actuator moves from the front end position to the rear end position. In a 3-position travel, the actuator moves from the front end position to the intermediate position, then to the rear end position.

#### BACK button

Moves the actuator back to the front end position.

#### RUN button

Starts continuous operation of the actuator. In a 2-position travel, the actuator moves back and forth between the front end and rear end positions. In a 3-position travel, the actuator repeats its movement from the front end position intermediate position rear end position front end position.

#### STOP button

Stops the above operation.

### Terminology

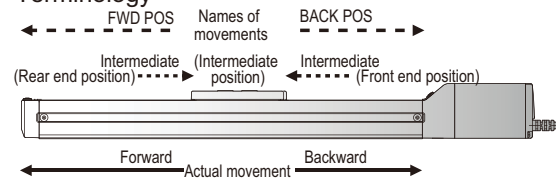

## Options

## ●Teaching Pendant for Position Controller

**Features** The Teaching Pendant is a data input device equipped with an interactive touch panel that is easy to use even for first-time users.

You can configure various settings, such as the front end, rear end, and intermediate positions, speed, pressing force, as well as make operational adjustments such as jogging, inching, and movement to reference positions.

### ■Model/Specifications/Pricing

Item	Description	
Model	Japanese version	CON-PT-M
	English version	CON-PT-M-ENG
Type	Standard type	
Features	Position data entry/editing	
	Move function (Move to position, Jog function, Inching function)	
	I/O signal test	
	Parameter editing	
Display	3-color LED backlight	
Ambient Operating Temp/Humidity	0~50°C 20~85%RH(no condensation)	
Environmental resistance	IP40	
Weight (including 5m cable)	Approximately 750g	
Accessory	Stylus	



### ■Part Names/Dimensions

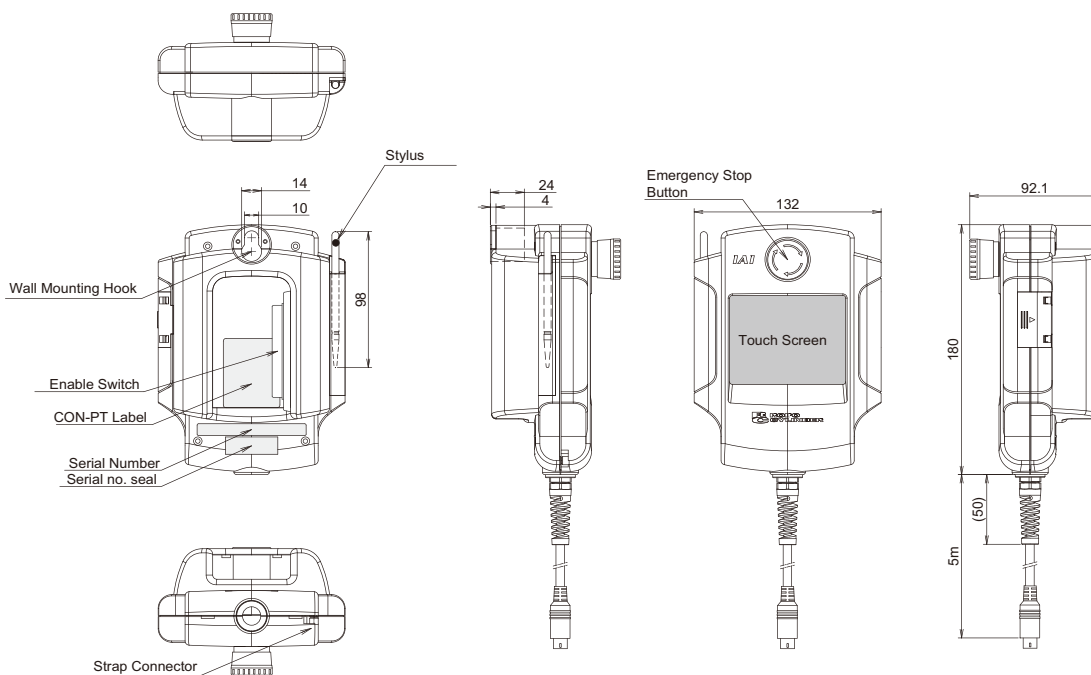

### ■Options

- STR-1 Strap



## ●DIN Rail Mounting Bracket MEC-AT-D

### ■Dimensions

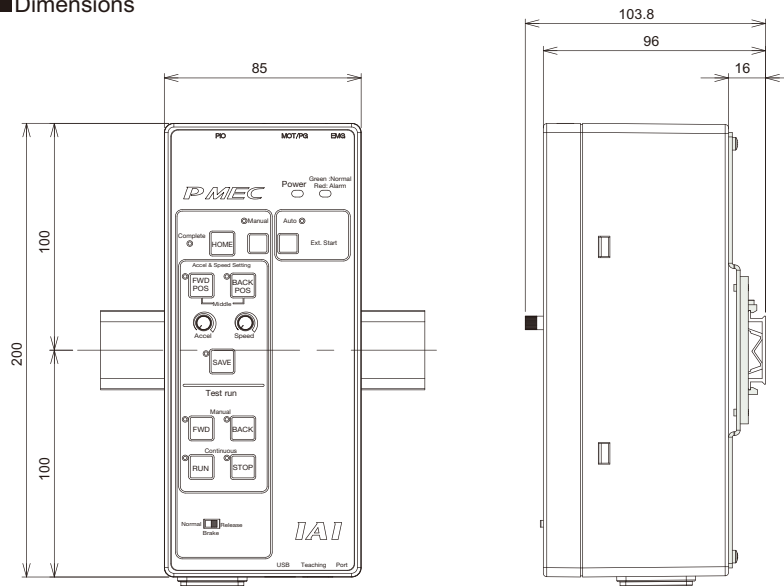

## ●Maintenance Cable

### ■List of Maintenance Cable Models and Pricing

Type		Cable Length	Model
Integrated motor-encoder cable	PMEC ↔ RCP3 AMEC ↔ RCA2/RCL	1m	CB-APSEP-MPA010
		3m	CB-APSEP-MPA030
		5m	CB-APSEP-MPA050
	PMEC ↔ RCP2	1m	CB-PSEP-MPA010
		3m	CB-PSEP-MPA030
		5m	CB-PSEP-MPA050
	AMEC ↔ RCA	1m	CB-ASEP-MPA010
		3m	CB-ASEP-MPA030
		5m	CB-ASEP-MPA050
I/O cable	2m	CB-APMEC-PIO020-NC	
	3m	CB-APMEC-PIO030-NC	
	5m	CB-APMEC-PIO050-NC	
USB cable	3m	CB-SEL-USB030	

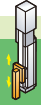

Slider (Vertical)

## ROBO Cylinder (Slider Type) RCP3-SA3C

Body Width: 32mm  
Pulse Motor, Coupling Type

### Model Descriptions

**RCP3** – **SA3C** – **I** – **28P** – **4** –   – **P3** – **M** – **B**

Series — Type — Encoder Type — Motor Type — Lead — Stroke — Applicable Controller — Cable Length — Option

I : Incremental    28P : Pulse motor (28 x 28 in size)    4 : 4mm    50 : 50mm to 300 : 300mm (Set stroke every 50mm)    P3 : PMEC    M : 5m    B : Brake-equipped

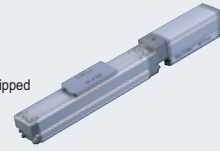

\* See page 30 for model descriptions.

### Actuator Specifications

#### Lead and Load Capacity

Model	Lead (mm)	Maximum Load Capacity Horizontal (kg)	Maximum Load Capacity Vertical (kg)	Maximum Pressing Force (N)	Stroke (mm)
RCP3-SA3C-I-28P-4-①-P3-M-B	4	2	1	22	50-300 (every 50mm)

Legend ① Stroke

#### Stroke and Maximum Speed

Lead	Stroke	50-300(every 50mm)
4		200

(Unit: mm/s)

### Actuator Specifications

Item	Description
Drive Method	Ball screw $\Phi 6$ mm, rolled C10
Positioning Repeatability	$\pm 0.02$ mm
Lost Motion	0.1 mm max.
Base	Material: Aluminum with special alumite processing
Allowable Static Moment	Ma:5.0N·m Mb:7.1N·m Mc:7.9 N·m
Allowable Dynamic Moment *	Ma:1.96N·m Mb:2.84N·m Mc:3.14N·m
Overhang Load Length	100 mm max.
Ambient Operating Temp./Humidity	0°C to 40°C at 85% RH or less (no condensation)

\* For a 5,000km running life.

#### Direction of Allowable Load Moment

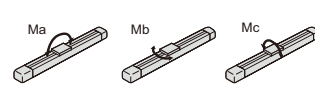

#### Overhang Load Length

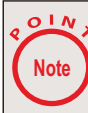
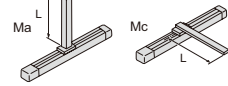

- Because the RCP3 series uses a pulse motor, the load capacity decreases at high speeds. Refer to the *Correlation Diagram of Speed and Load Capacity* on page 29 and check the load capacity at the desired speed.
- The load capacity is based on operation at an acceleration of 0.3G (or 0.2G for vertical operation).

### Dimensional Drawing

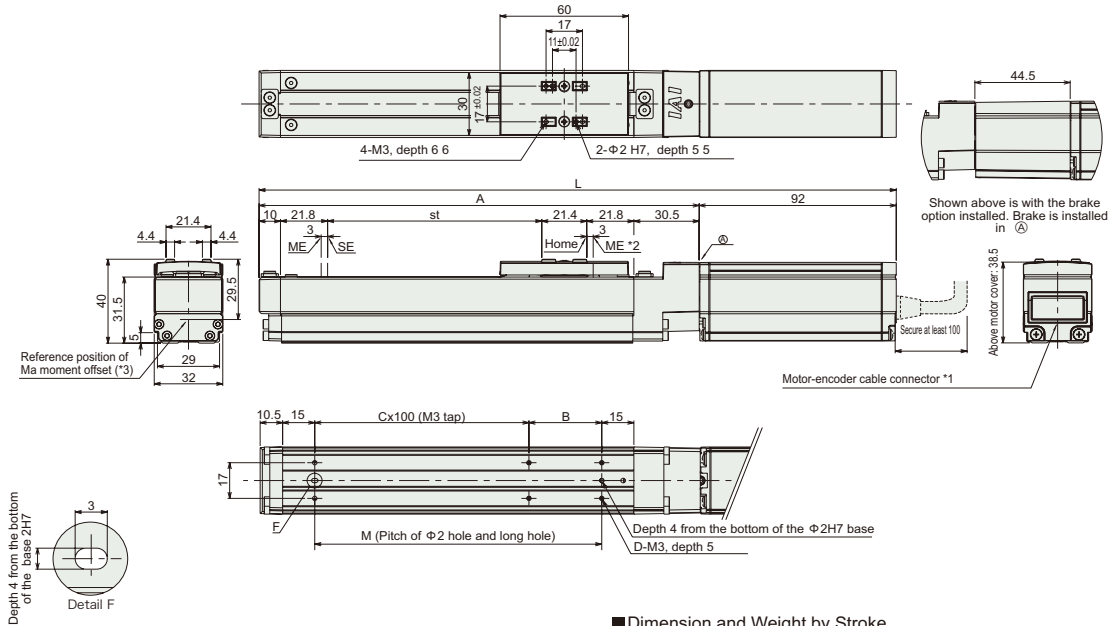

#### Dimension and Weight by Stroke

Stroke	50	100	150	200	250	300
	<b>L</b>					
No brake	247.5	297.5	347.5	397.5	447.5	497.5
Brake-equipped	292	342	392	442	492	542
<b>A</b>	155.5	205.5	255.5	305.5	355.5	405.5
<b>B</b>	84	34	84	34	84	34
<b>C</b>	0	1	1	2	2	3
<b>D</b>	4	6	6	8	8	10
<b>M</b>	84	134	184	234	284	334
<b>Weight (kg)</b>	0.7	0.7	0.8	0.9	0.9	1

\* The brake increases the weight by 0.2kg.

- Connect the motor-encoder cable (integrated).
- The slider will move to position ME after the actuator returns to the origin. Make sure that the slider will not interfere with any peripheral objects.  
ME: Mechanical end  
SE: Stroke end
- This is a reference position for calculating the Ma moment.

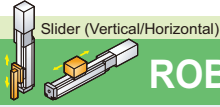

# ROBO Cylinder (Slider Type) RCP3-SA4C

Body Width: 40mm  
Pulse Motor, Coupling Type

## Model Descriptions

**RCP3-SA4C-I-35P-10-□-□-P3-M-□**

Series — Type — Encoder Type — Motor Type — Lead — Stroke — Applicable Controller — Cable Length — Option

I : Incremental 35P Pulse motor 35 x 35 size 10 : 10mm 5 : 5mm to 50 : 50mm to 500 : 500mm (Set stroke every 50mm) P3 : PMEC M : 5m B : Brake

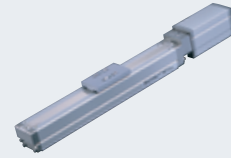

\* See page 30 for model descriptions.

## Actuator Specifications

### Lead and Load Capacity

Model	Lead (mm)	Maximum Load Capacity		Maximum Pressing Force (N)	Stroke (mm)
		Horizontal	Vertical		
RCP3-SA4C-I-35P-10-①-P3-M	10	2	~1.5	34	50~500 (every 50mm)
RCP3-SA4C-I-35P-5-①-P3-M-B	5	~9	~4	68	

### Stroke and Maximum Speed

Lead	Stroke	50~500(every 50mm)
		10
5		250

(Unit: mm/s)

## Actuator Specifications

Item	Description
Drive Method	Ball screw, $\Phi 8$ mm, rolled C10
Positioning Repeatability	$\pm 0.02$ mm
Lost Motion	0.1mm or less
Base	Material: Aluminum with special alumite treatment
Allowable Static Moment	Ma:6.8N·m Mb:9.7N·m Mc:13.3N·m
Allowable Dynamic Moment *	Ma:3.04N·m Mb:4.31N·m Mc:5.00N·m
Overhang Load Length	120 mm or less
Ambient Operating Temp/Humidity	0°C to 40°C at 85% RH or less (no condensation)

\* For a 5,000km running life.

### Direction of Allowable Load Moment

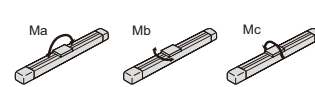

### Overhang Load Length

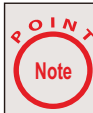
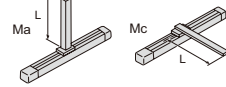

- Because the RCP3 series uses a pulse motor, the load capacity decreases at high speeds. Refer to the *Correlation Diagram of Speed and Load Capacity* on page 29 and check the load capacity at the desired speed.
- The load capacity is based on operation at an acceleration of 0.3G (or 0.2G for vertical operation).

## Dimensional Drawing

CAD data can be downloaded from IAI's website.

[www.intelligentactuator.com](http://www.intelligentactuator.com)

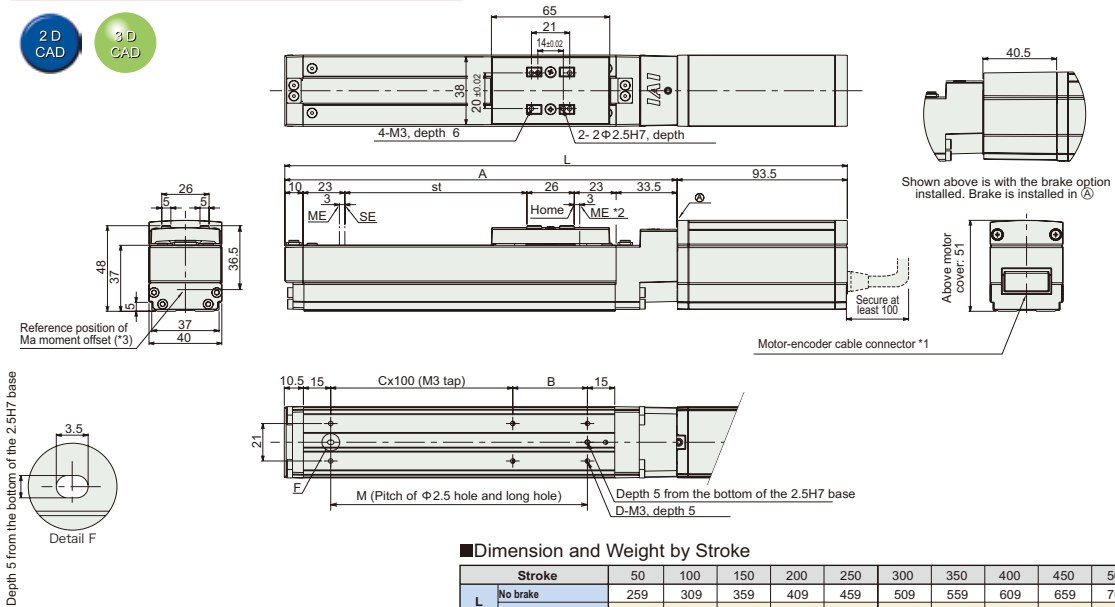

### Dimension and Weight by Stroke

Stroke	50	100	150	200	250	300	350	400	450	500
	<b>L</b>	No brake: 259	309	359	409	459	509	559	609	659
	Brake-equipped: 299.5	349.5	399.5	449.5	499.5	549.5	599.5	649.5	699.5	749.5
<b>A</b>	165.5	215.5	265.5	315.5	365.5	415.5	465.5	515.5	565.5	615.5
<b>B</b>	91	41	91	41	91	41	91	41	91	41
<b>C</b>	0	1	1	2	2	3	3	4	4	5
<b>D</b>	4	6	6	8	8	10	10	12	12	14
<b>M</b>	91	141	191	241	291	341	391	441	491	541
<b>Weight (kg)</b>	0.9	1	1.1	1.2	1.3	1.4	1.5	1.6	1.5	1.5

\* The brake increases the weight by 0.3 kg.

- Connect the motor-encoder cable (integrated).
- The slider will move to position ME after the actuator returns to the origin. Make sure that the slider will not interfere with any peripheral objects.  
ME: Mechanical end  
SE: Stroke end
- This is a reference position for calculating the Ma moment.



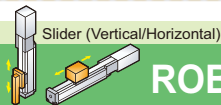

## ROBO Cylinder (Slider Type) RCP3-SA5C Body Width: 52mm Pulse Motor, Straight Type

### Model Number

**RCP3-SA5C-I-42P-□-□-P3-M-□**

Series - Type - Encoder Type - Motor Type - Lead - Stroke - Applicable Controller - Cable Length - Option

I : Incremental    42P : Pulse Motor 12 : 12mm to 6 : 6mm to 3 : 3mm (42 x 42 in size)  
 50 : 50mm to 800 : 800mm (Set stroke every 50mm)  
 P3 : P.MEC  
 M : 5m  
 B : Brake

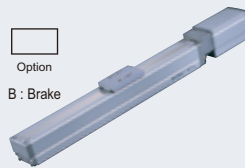

\* See page 30 for model descriptions.

### Actuator Specifications

#### Lead and Load Capacity

Model	Lead (mm)	Maximum Load Capacity		Max. pressing force (N)	Stroke (mm)
		Horizontal (kg)	Vertical (kg)		
RCP3-SA5C-I-42P-12-①-P3-M	12	~6	~2	47	50~800 (every 50mm)
RCP3-SA5C-I-42P-6-①-P3-M-B	6	~10	~5	95	
RCP3-SA5C-I-42P-3-①-P3-M-B	3	~19	~10	189	

Legend: ① Stroke

#### Stroke and Maximum Speed

Lead	Stroke	50 to 550	600	650	700	750	800
		(every 50mm)	(mm)	(mm)	(mm)	(mm)	(mm)
12		600	570	490	425	370	330
6		300	285	245	210	185	165
3		150	140	120	105	90	80

(Unit: mm/s)

### Actuator Specifications

Item	Description
Driving method	Ball screw, φ10mm, rolled C10
Positioning Repeatability	± 0.02mm
Lost Motion	0.1mm or less
Base	Material: Aluminum with special alumite treatment
Allowable Static Moment	Ma:10.2N·m Mb:14.6N·m Mc:22.4N·m
Allowable Dynamic Moment *	Ma:3.92N·m Mb:5.58N·m Mc:8.53N·m
Overhang Load Length	130mm or less
Ambient Operating Temp/Humidity	0°C to 40°C at 85% RH or less (no condensation)

\* For a 5,000km running life.

#### Direction of Allowable Load Moment

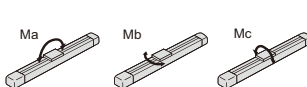

#### Overhang Load Length

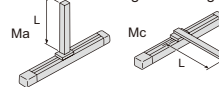

**POINT Note**

(1) Because the RCP3 series uses a pulse motor, the load capacity decreases at high speeds. Refer to the *Correlation Diagram of Speed and Load Capacity* on page 29 and check the load capacity at the desired speed.  
 (2) The load capacity is based on operation at an acceleration of 0.3G (or 0.2G for vertical operation).

### Dimensional Drawing

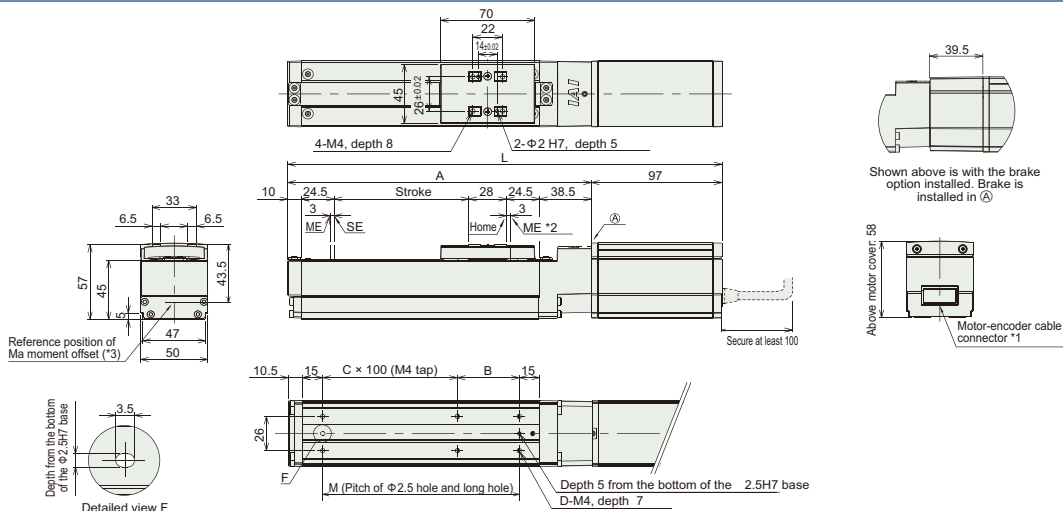

\*1 Connect the motor-encoder cable (integrated).  
 \*2 The slider will move to position ME after the actuator returns to the origin. Make sure that the slider will not interfere with any peripheral objects.  
 \*3 This is a reference position for calculating the Ma moment.

#### Dimension and Weight by Stroke

Stroke	50	100	150	200	250	300	350	400	450	500	550	600	650	700	750	800	
L	No brake	272.5	322.5	372.5	422.5	472.5	522.5	572.5	622.5	672.5	722.5	772.5	822.5	872.5	922.5	972.5	1022.5
	Brake-equipped	312	362	412	462	512	562	612	662	712	762	812	862	912	962	1012	1062
A	175.5	225.5	275.5	325.5	375.5	425.5	475.5	525.5	575.5	625.5	675.5	725.5	775.5	825.5	875.5	925.5	
B	96	46	96	46	96	46	96	46	96	46	96	46	96	46	96	46	
C	0	1	1	2	2	3	3	4	4	5	5	6	6	7	7	8	
D	4	6	6	8	8	10	10	12	12	14	14	16	16	18	18	20	
M	96	146	196	246	296	346	396	446	496	546	596	646	696	746	796	846	
Weight (kg)	1.4	1.5	1.6	1.8	1.9	2	2.2	2.3	2.5	2.6	2.7	2.9	3.0	3.2	3.3	3.4	

\* The brake increases the weight by 0.4kg.

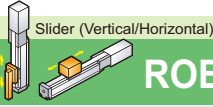

# ROBO Cylinder (Slider Type) RCP2-SA5C Body Width: 52mm Pulse Motor, Straight Type

## Model Number

**RCP2-SA5C** - **I** - **42P** -   -   - **P3** - **M** -  

Series - Type - Encoder Type - Motor Type - Lead - Stroke - Applicable Controller - Cable Length - Option

I: Incremental 42P: Pulse Motor (42 x 42 in size) 12: 12mm to 6: 6mm 50: 50mm to 800: 800mm (Set stroke every 50mm) P3: PMEC M: 5m BL: Brake (Cable exiting the left)

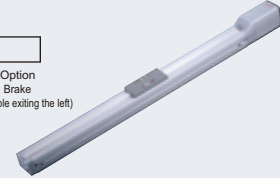

\* See page 30 for model descriptions.

## Actuator Specifications

### Lead and Load Capacity

Model	Lead (mm)	Maximum Load Capacity Horizontal (kg) Vertical (kg)	Stroke (mm)
RCP2-SA5C-I-42P-12-①-P3-M	12	~6 1	50 to 800 (every 50mm)
RCP2-SA5C-I-42P-6-①-P3-M-BL	6	~13 ~4	

Legend: ① Stroke

### Stroke and Maximum Speed

Stroke / Lead	50 to 550 (every 50mm)	600 (mm)	650 (mm)	700 (mm)	750 (mm)	800 (mm)
12	600	540	460	400	360	300
6	300	270	230	200	180	150

(Unit: mm/s)

## Actuator Specifications

Item	Description
Driving method	Ball screw, $\Phi$ 10mm, rolled C10
Positioning Repeatability	$\pm 0.02$ mm
Lost Motion	0.1mm or less
Base	Material: Aluminum with special alumite treatment
Allowable Static Moment	Ma: 18.6N·m Mb: 26.6N·m Mc: 47.5N·m
Allowable Dynamic Moment *	Ma: 4.9N·m Mb: 6.8N·m Mc: 11.7N·m
Overhang Load Length	Ma direction: Mb/Mc directions: 150 mm or less
Ambient Operating Temp/Humidity	0°C to 40°C at 85% RH or less (no condensation)

\* The permissible dynamic moment values are provided on the condition that the actuator has a travelling life of 5,000 km.

**POINT Note**

(1) As the stroke length increases, the maximum speed decreases due to hazardous ball screw RPMs. Check the maximum desired stroke speed in the Actuator Spec Table below.

(2) Because the RCP2 series uses a pulse motor, the load capacity decreases at high speeds. Refer to the Correlation Diagram of Speed and Load Capacity on page 29 and check the load capacity at the desired speed.

(3) The load capacity is based on operation at an acceleration of 0.3G (or 0.2G for vertical operation with lead 3). The above values are the upper limit for the acceleration.

Direction of Allowable Load Moment

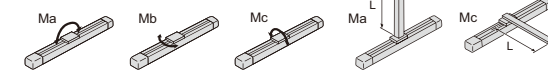

## Dimensional Drawing

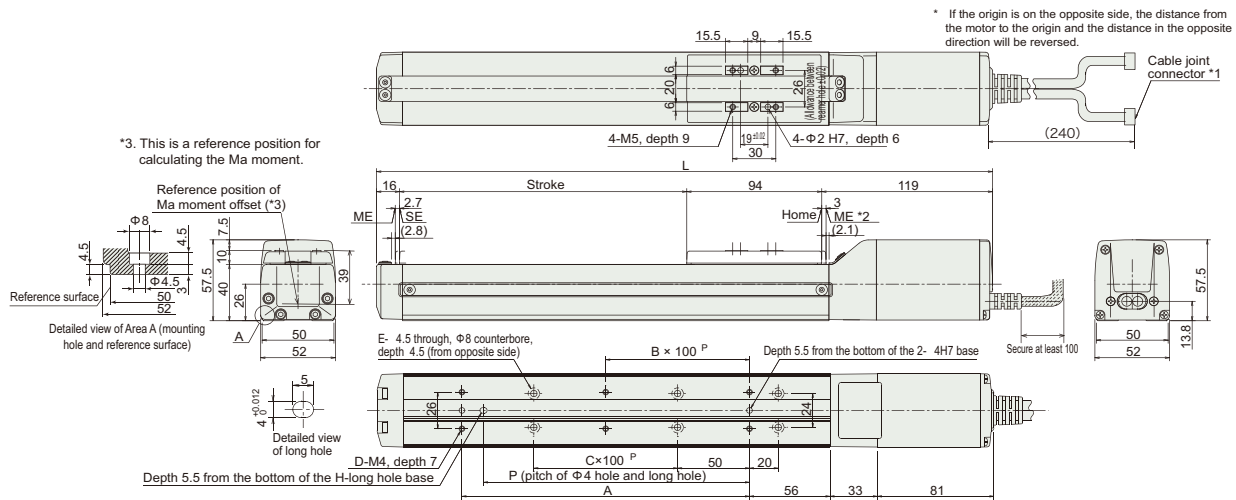

### Brake dimensions

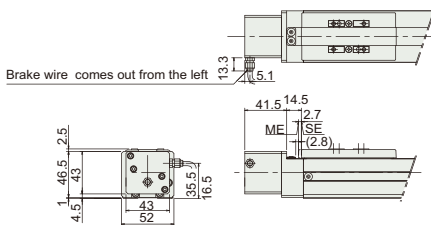

### Dimension and Weight by Stroke

Stroke L	50	100	150	200	250	300	350	400	450	500	550	600	650	700	750	800
L	279	329	379	429	479	529	579	629	679	729	779	829	879	929	979	1029
A	73	100	100	200	200	300	300	400	400	500	500	600	600	700	700	800
B	0	0	0	1	1	2	2	3	3	4	4	5	5	6	6	7
C	0	0	1	1	2	2	3	3	4	4	5	5	6	6	7	7
D	4	4	4	6	6	8	8	10	10	12	12	14	14	16	16	18
E	4	4	6	6	8	8	10	10	12	12	14	14	16	16	18	18
H	0	1	1	1	1	1	1	1	1	1	1	1	1	1	1	1
P	0	85	85	185	185	285	285	385	385	485	485	585	585	685	685	785
Weight (kg)	1.5	1.6	1.7	1.8	1.9	2.1	2.2	2.3	2.4	2.5	2.6	2.8	2.9	3.0	3.1	3.2

Slider (Horizontal)

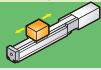

## ROBO Cylinder (Slider Type) RCP2-SA7C

Body Width: 73mm  
Pulse Motor, Straight Type

### Model Number

**RCP2 SA7C** - **I** - **56P** - **16** -   - **P3** - **M**

Series - Type - Encoder Type - Motor Type - Lead - Stroke - Applicable Controller - Cable Length

I : Incremental    56P : Pulse Motor (56 x 56 in size)    16 : 16mm    50 : 50mm to 800 : 800mm (Set stroke every 50mm)    P3 : P.MEC    M : 5m

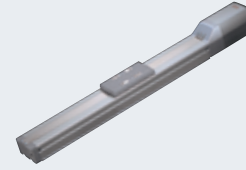

\* See page 30 for model descriptions.

### Actuator Specifications

#### Lead and Load Capacity

Note 1: Please note that the maximum load capacity will decrease when the speed increases.

Model	Lead (mm)	Maximum Load Capacity		Stroke (mm)
		Horizontal (kg)	Vertical (kg)	
RCP2-SA7C-I-56P-16-①-P3-M	16	~35	-	50 to 800 (every 50mm)

Legend: ① Stroke

#### Stroke and Maximum Speed

Lead	Stroke	50 to 700 (every 50mm)	~800 (mm)
		16	533

(Unit: mm/s)

### Actuator Specifications

Item	Description
Drive Method	Ball screw, $\Phi$ 12mm, rolled C10
Positioning Repeatability	$\pm 0.02$ mm
Lost Motion	0.1mm or less
Base	Material: Aluminum with special alumite treatment
Allowable Static Moment	Ma: 50.4N·m Mb: 71.9N·m Mc: 138.0N·m
Allowable Dynamic Moment *	Ma: 13.9N·m Mb: 19.9N·m Mc: 38.3N·m
Overhang Load Length	Ma direction: Mb/Mc directions: 230 mm or less
Ambient Operating Temp/Humidity	0°C to 40°C at 85% RH or less (no condensation)

\* For a 5,000km running life.

Direction of Allowable Load Moment

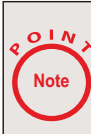
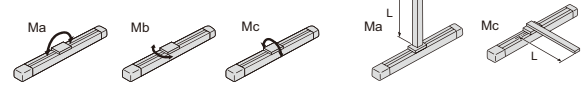

- As the stroke length increases, the maximum speed decreases due to hazardous ball screw RPMs. Check the maximum desired stroke speed in the Actuator Spec Table below.
- Because the RCP2 series uses a pulse motor, the load capacity decreases at high speeds. Refer to the Correlation Diagram of Speed and Load Capacity on page 29 and check the load capacity at the desired speed.
- The load capacity is based on operation at an acceleration of 0.3G (or 0.2G for vertical operation with lead 4). The above values are the upper limit for the acceleration.

### Dimensional Drawing

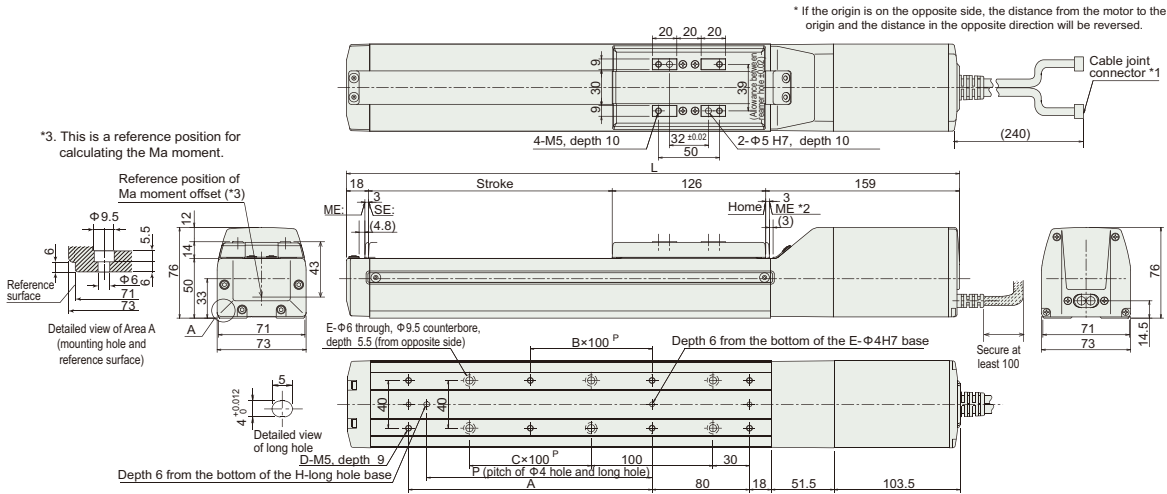

- Connect the motor-encoder cable.
  - The slider will move to position ME after the actuator returns to the origin. Make sure that the slider will not interfere with any peripheral objects. ME: Mechanical end; SE: Stroke end
- Dimensions in parentheses are reference values.

#### Dimensions and Weight by Stroke

Stroke	50	100	150	200	250	300	350	400	450	500	550	600	650	700	750	800
L	353	403	453	503	553	603	653	703	753	803	853	903	953	1003	1053	1103
A	0	100	100	200	200	300	300	400	400	500	500	600	600	700	700	800
B	0	0	0	1	1	2	2	3	3	4	4	5	5	6	6	7
C	0	0	1	1	2	2	3	3	4	4	5	5	6	6	7	7
D	4	6	6	8	8	10	10	12	12	14	14	16	16	18	18	20
E	2	3	3	3	3	3	3	3	3	3	3	3	3	3	3	3
F	4	4	6	6	8	8	10	10	12	12	14	14	16	16	18	18
H	0	1	1	1	1	1	1	1	1	1	1	1	1	1	1	1
P	0	85	85	185	185	285	285	385	385	485	485	585	585	685	685	785
Weight (kg)	3.1	3.3	3.6	3.8	4.0	4.2	4.5	4.7	4.9	5.1	5.4	5.6	5.8	6.0	6.3	6.5

Rod (Vertical/Horizontal)

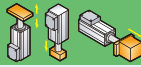

# ROBO Cylinder (Rod Type) RCP2-RA4C

Body Width: 73mm  
Pulse Motor, Straight Type

## Model Number

**RCP2-RA4C** - **I** - **42P** -   -   - **P3** - **M** -  

Series - Type - Encoder Type - Motor Type - Lead - Stroke - Applicable Controller - Cable Length - Option

I : Incremental  
42P : Pulse Motor (42 x 42 in size)  
10 : 10mm  
5 : 5mm  
2.5 : 2.5mm  
50 : 50mm to 300 : 300mm (Set stroke every 50mm)  
P3 : P MEC  
M : 5m  
B : Brake

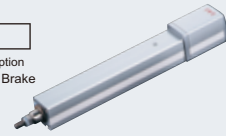

\* See page 30 for model descriptions.

## Actuator Specifications

### Lead and Load Capacity

Note 1: Please note that the maximum load capacity will decrease when the speed increases.

Model	Lead (mm)	Maximum Load Capacity		Max. Pressing Force (N)	Stroke (mm)
		Horizontal (kg)	Vertical (kg)		
RCP2-RA4C-I-42P-10-①-P3-M	10	~25	~4.5	150	50 to 300 (every 50mm)
RCP2-RA4C-I-42P-5-①-P3-M-②	5	~40	~12	284	
RCP2-RA4C-I-42P-2.5-①-P3-M-②	2.5	40	~19	358	

Legend: ① Stroke ② Option: ("B" indicates a model with a brake)

### Stroke and Maximum Speed

Lead	Stroke	50 to 200 (every 50mm)	250 (mm)	300 (mm)
		10	458	458
5	250	237	175	
2.5	125	118	87	

\* Values in parenthesis apply to vertical operation.

(Unit: mm/s)

## Actuator Specifications

Item	Description
Drive Method	Ball screw, $\phi$ 8mm, rolled C10
Positioning Repeatability	$\pm 0.02$ mm
Lost Motion	0.1mm or less
Rod Diameter	$\phi$ 22mm
Rod Non-rotation Accuracy	$\pm 1.5^\circ$
Ambient Operating Temp/Humidity	0°C to 40°C at 85% RH or less (no condensation)

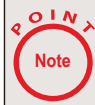

- (1) As the stroke length increases, the maximum speed decreases due to hazardous ball screw RPMs. Check the maximum desired stroke speed in the Actuator Spec Table below.
- (2) Because the RCP2 series uses a pulse motor, the load capacity decreases at high speeds. Refer to the Correlation Diagram of Speed and Load Capacity on page 29 and check the load capacity at the desired speed.
- (3) The load capacity is based on operation at an acceleration of 0.2G. 0.2G is the upper limit of the acceleration. In addition, the horizontal load capacity assumes use of an external guide. Please note that if external force is applied to the rod in a direction other than the proper direction the rod travels, the detent may get damaged.

## Dimensional Drawing

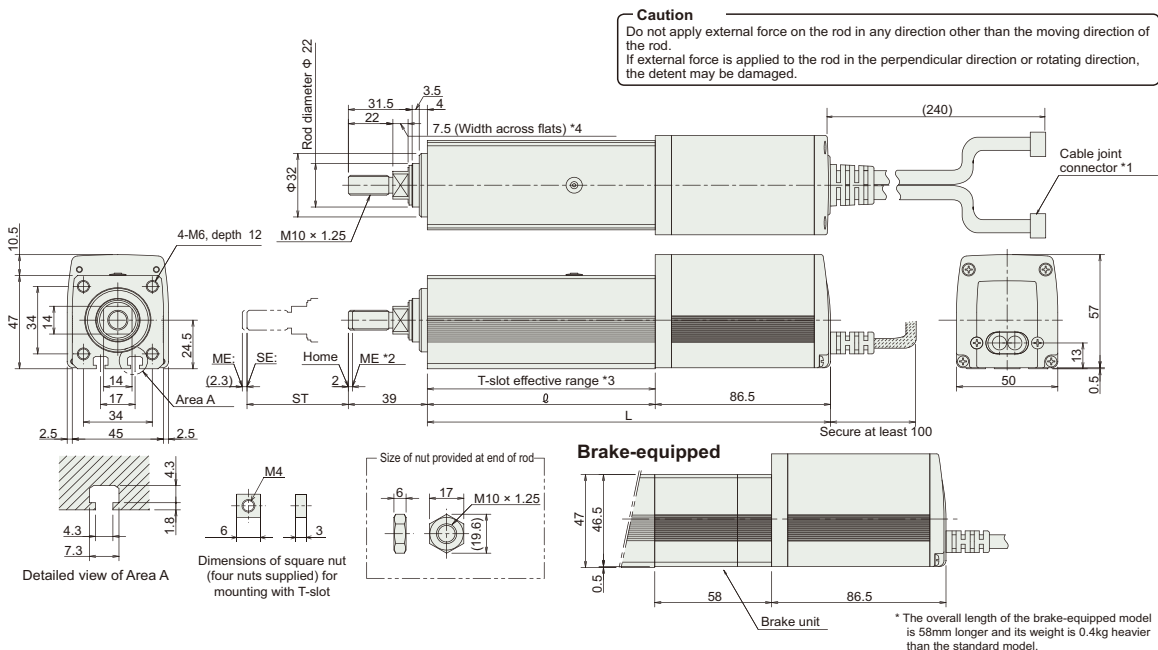

- \*1. Connect the motor-encoder cable.
- \*2. The rod will move to position ME after the actuator returns to the origin. Make sure that the slider will not interfere with any peripheral objects. ME: Mechanical end; SE: Stroke end
- \*3. Please note that there is no T-slot on the bottom of the brake unit.
- \*4. The orientation of the surface of the width across flats varies with each product. The dimensions in parentheses are reference values.

### Dimensions and Weight by Stroke

Stroke	50	100	150	200	250	300
L	112.5	162.5	212.5	262.5	312.5	362.5
Weight (kg)	1.35	1.6	1.85	2.1	2.35	2.6

\* The overall length of the brake-equipped model is 58mm longer and its weight is 0.4kg heavier than the standard model.

## Correlation Diagram of Speed and Load Capacity

The load capacity decreases as the speed increases, due to the characteristics of the pulse motor used in the actuator.

Use the graph below to check if the desired speed and load capacity are satisfied.

RCP3-SA3C

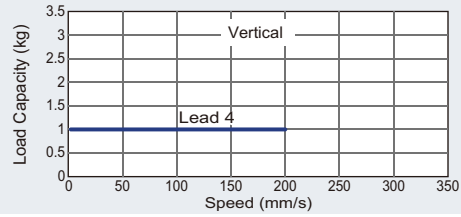

RCP3-SA4C

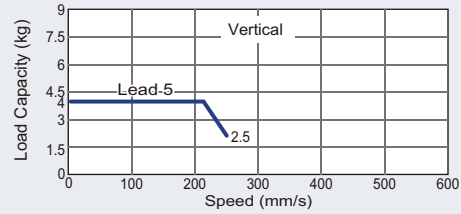
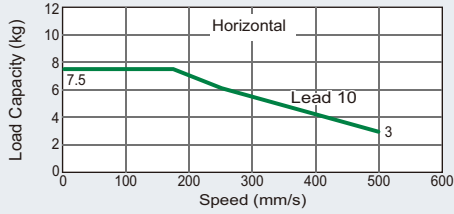

RCP3-SA5C

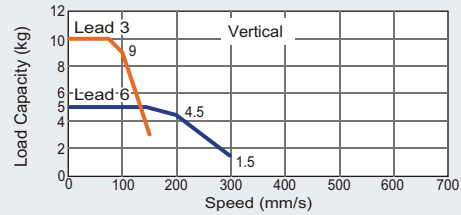
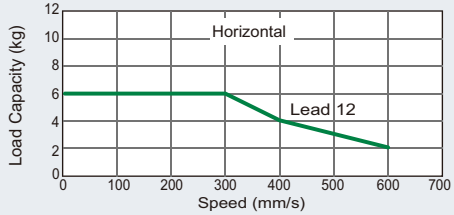

RCP2-SA5C

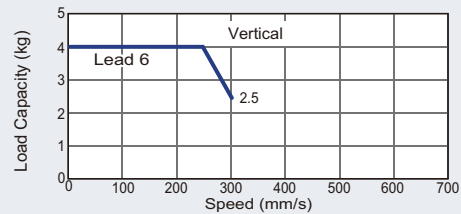
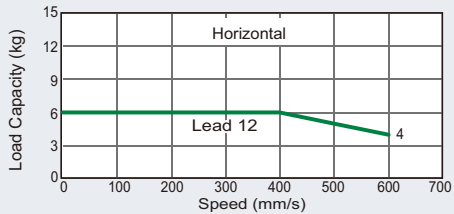

RCP2-SA7C

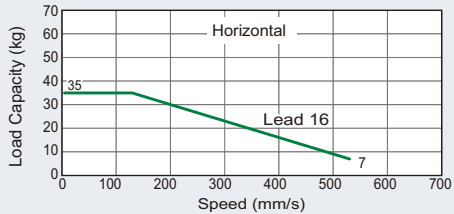

RCP2-RA4C

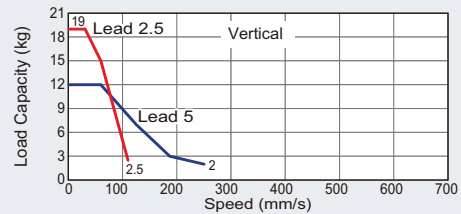
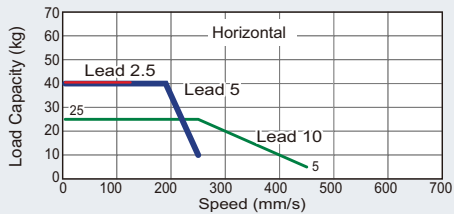



## Type Description

Model numbers for each series of ROBO Cylinder consist of the following identifiers. For details, see the explanation below:

The range of selection for an identifier (e.g., lead, stroke) varies with each model. For details, refer to the description of each specific model.

### Explanations of Identifiers



① <b>Series</b>	Indicates the name of the series.																		
② <b>Type</b>	Indicates the shape (e.g., the slider or rod type), material (e.g., aluminum or steel), size (e.g., 52mm wide), and motor coupling method of each model as shown below.																		
	<table border="1"> <thead> <tr> <th>Type</th> <th>Material/Guide</th> <th>Body Width</th> <th>Motor Coupling method</th> </tr> </thead> <tbody> <tr> <td>S (Slider)</td> <td rowspan="5">A (Aluminum)</td> <td>3 (Width: 30)</td> <td rowspan="5">C (Coupling)</td> </tr> <tr> <td rowspan="4">R (Rod)</td> <td>4 (Width: 40/42/45)</td> </tr> <tr> <td>5 (Width: 52/54/55)</td> </tr> <tr> <td>6 (Width: 58/64)</td> </tr> <tr> <td>7 (Width: 60/68)</td> </tr> </tbody> </table>	Type	Material/Guide	Body Width	Motor Coupling method	S (Slider)	A (Aluminum)	3 (Width: 30)	C (Coupling)	R (Rod)	4 (Width: 40/42/45)	5 (Width: 52/54/55)	6 (Width: 58/64)	7 (Width: 60/68)	<table border="1"> <tr> <td>Example : SA5C</td> </tr> <tr> <td>Shape : Slider</td> </tr> <tr> <td>Material : Aluminum</td> </tr> <tr> <td>Body Width: 52mm</td> </tr> <tr> <td>Motor : Coupling specification</td> </tr> </table>	Example : SA5C	Shape : Slider	Material : Aluminum	Body Width: 52mm
Type	Material/Guide	Body Width	Motor Coupling method																
S (Slider)	A (Aluminum)	3 (Width: 30)	C (Coupling)																
R (Rod)		4 (Width: 40/42/45)																	
		5 (Width: 52/54/55)																	
		6 (Width: 58/64)																	
		7 (Width: 60/68)																	
Example : SA5C																			
Shape : Slider																			
Material : Aluminum																			
Body Width: 52mm																			
Motor : Coupling specification																			
* Gripper and rotary are unique models.																			
③ <b>Encoder Type</b>	Indicates the type of encoder mounted to the actuator (absolute type or incremental type).																		
	I: Incremental	The position data of the slider gets erased when the ROBO Cylinder is powered off. Therefore, homing is required each time the ROBO Cylinder is powered on.																	
④ <b>Motor Type</b>	Indicates the type of motor used in the actuator. Because the RCP3/RCP2 series uses a pulse motor, the motor type indicates the size of the motor (i.e., 20P for 20-□ motor).																		
⑤ <b>Lead</b>	Indicates the lead of the ball screw (i.e., the travel distance of the slider when the ball screw rotates once).																		
⑥ <b>Stroke</b>	Indicates the stroke (range of motion) of the actuator (in mm or degrees).																		
⑦ <b>Applicable Controller (I/O type)</b>	Indicates the type of controller that can be connected.																		
⑧ <b>Cable Length</b>	Indicates the length of motor-encoder cable that connects the actuator and the controller.																		
⑨ <b>Options</b>	Indicates the types of options attached to the actuator. * If you are selecting multiple options, specify them in alphabetical order (e.g., A3-B-FT).																		