



■ Models C / CG / CY / PL / PO / SE

Position Controllers  
For RCA2/RCA

C/CG CY PL/PO SE

List of models

This position controller enables movement of the RCA2/RCA series actuators. A line-up of 5 types to support various controlling methods.

Type	C	CG	CY	PL/PO	SE
Name	Positioner type	Safety category compatible type	Solenoid valve type	Pulse train control type	Serial Communication Type
External view					
Description	Positioner capable of a maximum of 512 points of Positioning	Conforming to type C safety category specifications	Can be operated using the same control as the air cylinder type	For pulse train control	For serial communication
Position points	512 points	512 points	3 points	(-)	64 points

Model

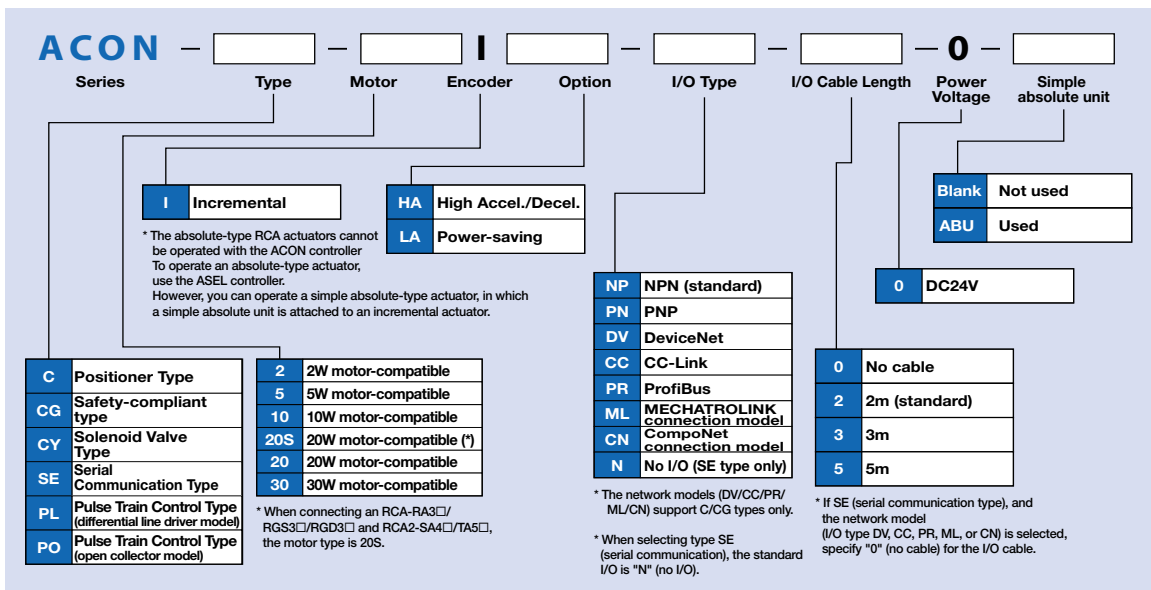

535 ACON

Sold & Serviced By: ELECTROMATE

Toll Free Phone (877) SERV098  
Toll Free Fax (877) SERV099  
www.electromate.com  
sales@electromate.com

- Slider Type
- Mini
- Standard
- Controllers Integrated
- Pod Type
- Mini
- Standard
- Controllers Integrated
- Table/Arm /FlatType
- Mini
- Standard
- Gripper/ Rotary Type
- Linear Servo Type
- Cleanroom Type
- Splash-Proof
- Controllers
- PMEC /AMEC
- PSEP /ASEP
- ROBO NET
- ERC2
- PCON
- ACON
- SCON
- PSEL
- ASEL
- SSEL
- XSEL
- Pulse Motor
- Servo Motor (24V)
- Servo Motor (200V)
- Linear Servo Motor

System configuration

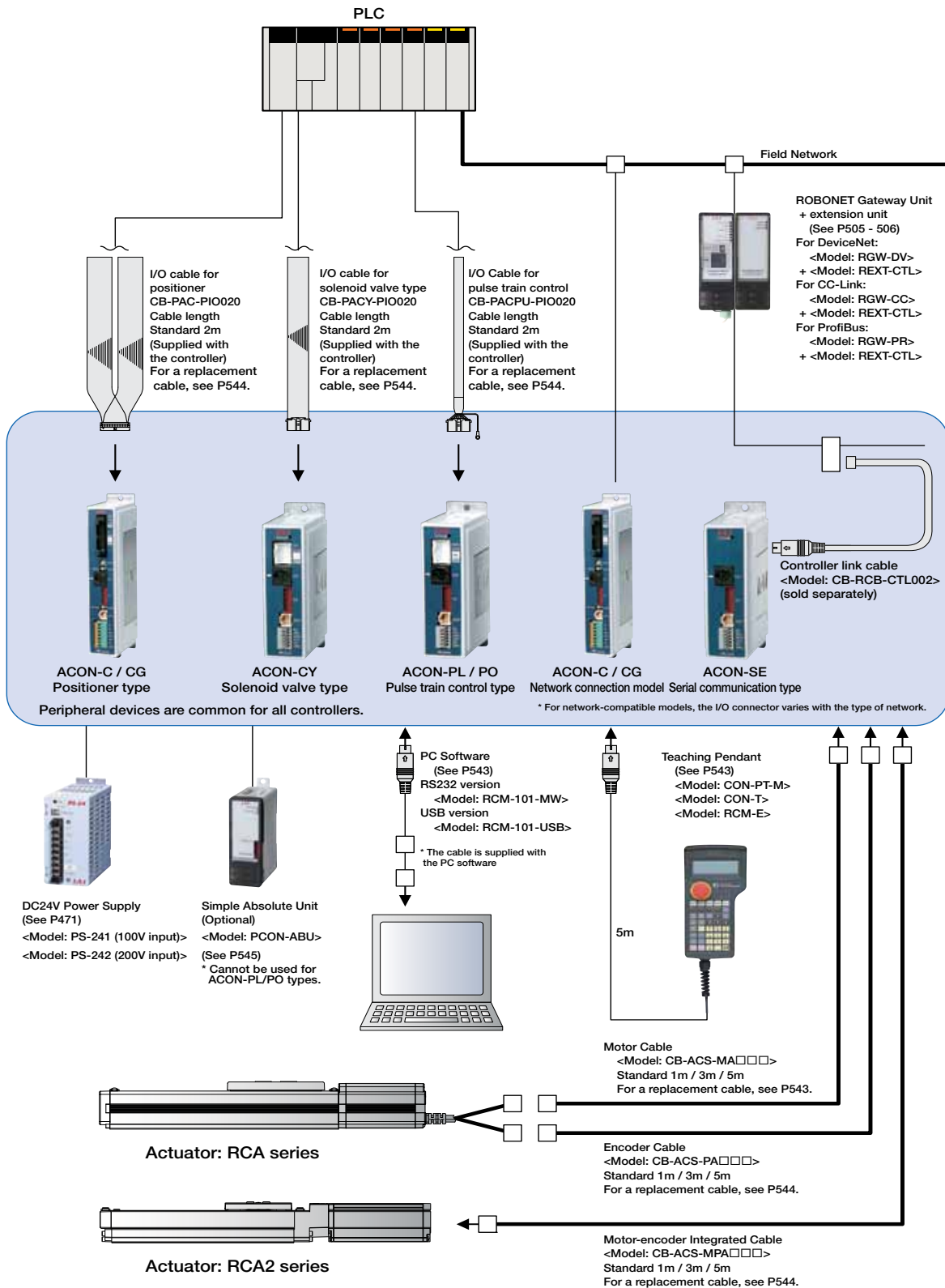

- Slider Type
- Mini
- Standard
- Controllers Integrated
- Pcd Type
- Mini
- Standard
- Controllers Integrated
- Table/Arm /FlatType
- Mini
- Standard
- Gripper/ Rotary Type
- Linear Servo Type
- Cleanroom Type
- Splash-Prod
- Controllers
- PMEC /AMEC
- PSEP /ASEP
- ROBO NET
- ERC2
- PCON
- ACON
- SCON
- PSEL
- ASEL
- SSEL
- XSEL
- Pulse Motor
- Servo Motor (24V)
- Servo Motor (200V)
- Linear Servo Motor

## I/O Specifications

### Input section External input specifications

Item	Specifications
Input voltage	DC24V ±10%
Input current	4mA/circuit
Leak current	1mA max./point
Isolation method	Photocoupler

#### NPN Specifications

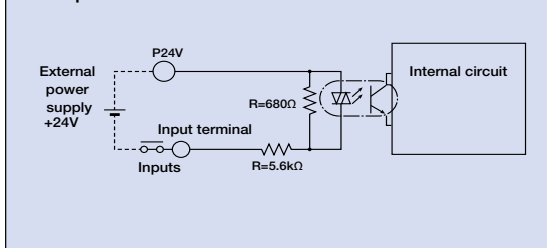

#### PNP Specifications

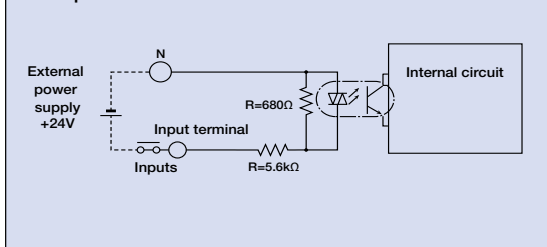

### Output section External output specifications

Item	Specifications
Load Voltage	DC24V
Max. load current	50mA/point
Remaining voltage	2V or less
Isolation method	Photocoupler

#### NPN Specifications

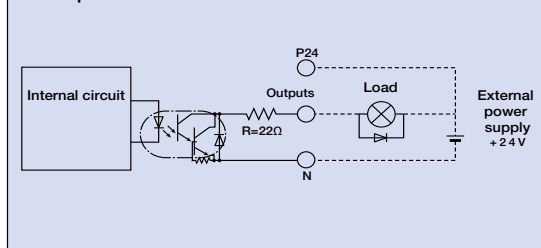

#### PNP Specifications

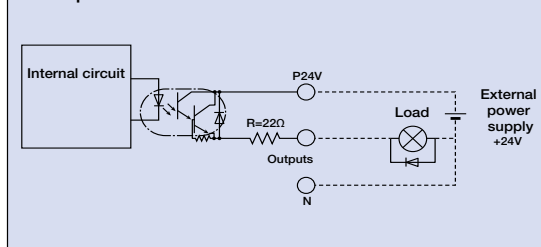

## I/O Specifications

The 4 types of controllers (C/CG, CY, PL/PO, and SE) are classified by their respective I/O specifications. Also, for the positioner type and solenoid valve type, the I/O signal information can be changed in the controller settings, so multiple functions can be effectively used.

### Control Function by Type

Type	C/CG	CY	PL/PO	SE	Features
Name	Positioner type	Solenoid valve type	Pulse train control type	Serial communication type	
Positioner mode	<input type="radio"/>	<input checked="" type="checkbox"/>	<input checked="" type="checkbox"/>	<input type="radio"/> (*1)	This is the basic operating mode, in which the user designates position numbers and inputs start signals.
Teaching mode	<input type="radio"/>	<input checked="" type="checkbox"/>	<input checked="" type="checkbox"/>	<input type="radio"/> (*1)	In this mode, the slider (rod) moves based on an external signal, and the stopped positions can be registered as position data.
Solenoid valve mode	<input type="radio"/>	<input type="radio"/>	<input checked="" type="checkbox"/>	<input type="radio"/> (*1)	The actuator can be moved simply by ON/OFF position signals. This mode supports the same control signals you are already familiar with on solenoid valves of air cylinders.
Pulse train mode	<input checked="" type="checkbox"/>	<input checked="" type="checkbox"/>	<input type="radio"/>	<input checked="" type="checkbox"/>	In this mode, you can operate the actuator freely without inputting position data.
Network compatible	<input type="radio"/> (*2)	<input checked="" type="checkbox"/>	<input checked="" type="checkbox"/>	<input type="radio"/> (*3)	The controller can be connected to a DeviceNet or CC-Link network.

\*1 Operates using network communications or serial communications.

\*2 Can make a direct connection to a field network with the network specifications.

\*3 Can be connected to a field network using a gateway unit.

# 537

ACON

Sold & Serviced By:

**ELECTROMATE**

Toll Free Phone (877) SERV098

Toll Free Fax (877) SERV099

www.electromate.com

sales@electromate.com

- Slider Type
- Mini
- Standard
- Controllers Integrated
- Rod Type
- Mini
- Standard
- Controllers Integrated
- Table/Arm /FlatType
- Mini
- Standard
- Gripper/ Rotary Type
- Linear Servo Type
- Cleanroom Type
- Splash-Proof
- Controllers
- PMEC /AMEC
- PSEP /ASEP
- ROBO NET
- ERC2
- PCON
- ACON
- SCON
- PSEL
- ASEL
- SSEL
- XSEL
- Pulse Motor
- Servo Motor (24V)
- Servo Motor (200V)
- Linear Servo Motor

Explanation of I/O Signal Functions

The table below explains the functions allocated to the controller's I/O signal. Since the signals that can be used vary depending on the controller type and settings, check the signal table for each controller to confirm the available functions.

■ Signal Function Description

Classification	Signal abbreviations	Signal	Function description
Input	CSTR	Start signal	Input this signal to cause the actuator to start moving to the position set by the command position number signal.
	PC1 to PC256	Command position number signal	This signal is used to input a target position number (binary input).
	BKRL	Brake forced release signal	This signal forcibly releases the brake.
	RMOD	Running mode switching signal	This signal can switch the running mode when the MODE switch on the controller is set to AUTO. (AUTO when this signal is OFF, or MANU when the signal is ON).
	* STP	Pause signal	Turning this signal OFF causes the moving actuator to decelerate to a stop. The actuator will resume the remaining movement if the signal is turned ON during the pause.
	RES	Reset signal	Turning this signal ON resets the alarms that are present. If this signal is turned ON while the actuator is paused (*STP is OFF), the remaining movement can be cancelled.
	SON	Servo ON signal	The servo remains on while this signal is ON, or off while the signal is OFF.
	HOME	Home return signal	Turning this signal ON performs home-return operation.
	MODE	Teaching mode signal	Turning this signal ON switches the controller to teaching mode (provided that CSTR, JOG+ and JOG- are all OFF and the actuator is not moving).
	JISL	JOG/INJOG switching signal	When the main signal is off, the JOG operation will be conducted for JOG+ and JOG-. When the signal is on, the unit will do the inching operation for JOG+ and JOG-.
	JOG+, JOG-	JOG signal	When the JISL signal is off and the JOG +/- signal turns on, the unit will jog in the + (positive) direction when the JOG + turns on and the - (negative) direction when the JOG - turns on. During the JOG operation, the unit slows to a stop when the JOG +/- signal turns off.
	PWRT	Teaching signal	In the teaching mode, specify a desired position number and then turn this signal ON for at least 20ms to write the current position to the specified position number.
	ST0 to ST6	Start position command	Turning this signal ON in the solenoid valve mode causes the actuator to move to the specified position. (Start signal is not required)
	TL	Torque limit selection signal	While this signal is ON, torque is limited by the value set by a parameter. The TLR signal turns on if torque has reached the specified value. (Dedicated pulse train type)
	Output	DCLR	Deviation counter clear signal
PEND/INP		In position signal	This signal turns ON when the actuator has entered the positioning band after movement. If the actuator has exceeded the positioning band, PEND does not turn OFF, but INP does. PEND and INP can be swapped within parameters.
PM1 to PM256		Position complete signal	This signal is used to output the position number achieved at the completion of positioning (binary output)
HEND		Home return completion signal	This signal turns ON upon completion of home return.
ZONE1		Zone signal	This signal turns ON when the current actuator position has entered the range specified by the parameters.
PZONE		Positioning zone signal	Turns ON when actuator moves into a position within the range of the target position data that was set. PZONE can be used together with ZONE1, but PZONE is valid only during movement to a specified position.
RMDS		Running mode status signal	This outputs the operation mode status.
* ALM		Controller alarm status signal	This signal remains ON while the controller is not in the alarm condition, and turns OFF when an alarm has occurred.
MOVE		Moving signal	Turns ON while the actuator is moving (home return), including when there is push force.
SV		Servo ON status signal	This signal turns ON when servo is ON.
* EMGS		Emergency stop status signal	This signal remains ON while the controller is not in the emergency stop mode, and turns OFF once an emergency stop has been actuated.
MODES		Mode status signal	The mode signal input turns it ON when it goes into teaching mode. It turns OFF when it goes into normal mode.
WEND		Writing complete signal	This signal remains OFF after the controller has switched to the teaching mode. It turns ON upon completion of data write using the PWRT signal. If the PWRT signal is turned Off, this signal also turns OFF.
PE0 to PE6		Current position number signal	This signal turns ON after the controller has completed moving to the target position in the solenoid valve mode.
TLR		Torque limiting signal	This signal turns ON once the motor torque has reached the specified value in a condition where torque is being limited by the TL signal. (Dedicated pulse train type)
LSO to LS2	Limit switch output signal	Each signal turns ON when the current actuator position has entered the positioning band before or after the target position. If the actuator has already completed home return, these signals are output even before a movement command is issued or while the servo is OFF. (Dedicated Solenoid Valve Mode)	

(Note) Signals with asterisks (\*) are normally ON and OFF during operation.

- Slider Type
- Mini
- Standard
- Controllers Integrated
- Pcd Type
- Mini
- Standard
- Controllers Integrated
- Table/Arm /FlatType
- Mini
- Standard
- Gripper/ Rotary Type
- Linear Servo Type
- Cleanroom Type
- Splash-Proof
- Controllers
- PMEC /AMEC
- PSEP /ASEP
- ROBO NET
- ERC2
- PCON
- ACON
- SCON
- PSEL
- ASEL
- SSEL
- XSEL
- Pulse Motor
- Servo Motor (24V)
- Servo Motor (200V)
- Linear Servo Motor

I/O Signal table

■ Positioner type (ACON-C / CG)

Pin No.	Classification	Positioning Points	Parameters (select PIO pattern)					
			0	1	2	3	4	5
			Positioning mode	Teaching mode	256-point mode	512-point mode	Solenoid Valve Mode 1	Solenoid Valve Mode 2
		Zone signal	○	x	x	x	○	○
		P-zone signal	○	○	○	x	○	○
1A	24V		P24					
2A	24V		P24					
3A	-		NC					
4A	-		NC					
5A	Input	IN0	PC1	PC1	PC1	PC1	ST0	ST0
6A		IN1	PC2	PC2	PC2	PC2	ST1	ST1 (JOG+)
7A		IN2	PC4	PC4	PC4	PC4	ST2	ST2 (-)
8A		IN3	PC8	PC8	PC8	PC8	ST3	-
9A		IN4	PC16	PC16	PC16	PC16	ST4	-
10A		IN5	PC32	PC32	PC32	PC32	ST5	-
11A		IN6	-	MODE	PC64	PC64	ST6	-
12A		IN7	-	JISL	PC128	PC128	-	-
13A		IN8	-	JOG+	-	PC256	-	-
14A		IN9	BKRL	JOG-	BKRL	BKRL	BKRL	BKRL
15A		IN10	RMOD	RMOD	RMOD	RMOD	RMOD	RMOD
16A		IN11	HOME	HOME	HOME	HOME	HOME	-
17A		IN12	* STP	* STP	* STP	* STP	* STP	-
18A		IN13	CSTR	CSTR/PWRT	CSTR	CSTR	-	-
19A		IN14	RES	RES	RES	RES	RES	RES
20A	IN15	SON	SON	SON	SON	SON	SON	
1B	Output	OUT0	PM1	PM1	PM1	PM1	PE0	LS0
2B		OUT1	PM2	PM2	PM2	PM2	PE1	LS1
3B		OUT2	PM4	PM4	PM4	PM4	PE2	LS2 (-)
4B		OUT3	PM8	PM8	PM8	PM8	PE3	-
5B		OUT4	PM16	PM16	PM16	PM16	PE4	-
6B		OUT5	PM32	PM32	PM32	PM32	PE5	-
7B		OUT6	MOVE	MOVE	PM64	PM64	PE6	-
8B		OUT7	ZONE1	MODES	PM128	PM128	ZONE1	ZONE1
9B		OUT8	PZONE	PZONE	PZONE	PM256	PZONE	PZONE
10B		OUT9	RMDS	RMDS	RMDS	RMDS	RMDS	RMDS
11B		OUT10	HEND	HEND	HEND	HEND	HEND	HEND
12B		OUT11	PEND	PEND/WEND	PEND	PEND	PEND	-
13B		OUT12	SV	SV	SV	SV	SV	SV
14B		OUT13	* EMGS	* EMGS	* EMGS	* EMGS	* EMGS	* EMGS
15B		OUT14	* ALM	* ALM	* ALM	* ALM	* ALM	* ALM
16B	OUT15	-	-	-	-	-	-	
17B	-		NC					
18B	-		NC					
19B	0V		N					
20B	0V		N					

(Note) The names of signals above inside ( ) are functions before the unit returns home.  
 (Note) Signals with asterisks (\*) are normally ON, and OFF during operation.

■ Solenoid valve type (ACON-CY)

Pin No.	Classification	Positioning Points	Parameters (select PIO pattern)	
			0	1
			Solenoid valve mode 0	Solenoid valve mode 1
		Zone signal	x	x
		P-zone signal	x	○
1	24V			
2	0V			
3	Input	IN0	ST0	ST0
4		IN1	ST1 (JOG+)	ST1 (JOG+)
5		IN2	ST2 (RES)	ST2 (RES)
6	IN3	SON	SON	
7	Output	OUT0	LS0	PE0
8		OUT1	LS1	PE1
9		OUT2	LS2 (-)	PE2 (-)
10		OUT3	SV	PZONE
11		OUT4	HEND	HEND
12	OUT5	* ALM	* ALM	

(Note) The names of signals above inside ( ) are functions before the unit returns home.  
 (Note) Signals with asterisks (\*) are normally ON, and OFF during operation.

■ Pulse Train Type (ACON-PL/PO)

Pin No.	Classification	Positioning Points	Parameters (select PIO pattern)	
			0	1
			Standard mode	Push mode
		Zone signal	x	x
		P-zone signal	x	x
1	24V			
2	0V			
3	Input	IN0	SON	SON
4		IN1	TL	TL
5		IN2	HOME	HOME
6	IN3	RES	RES / DCLR	
7	Output	OUT0	SV	SV
8		OUT1	INP	INP / TLR
9		OUT2	HEND	HEND
10		OUT3	* ALM	* ALM
11	Input		* PP	* PP
12			PP	PP
13			* NP	* NP
14			NP	NP

(Note) Signals with asterisks (\*) are normally ON, and OFF during operation.

539 ACON

Wiring Diagram for the Pulse-Train Input Type

■ Differential Line Driver Method (ACON-PL)

Max. input pulse frequency : Max. 200 kpps  
 Cable Length : Max. 10m

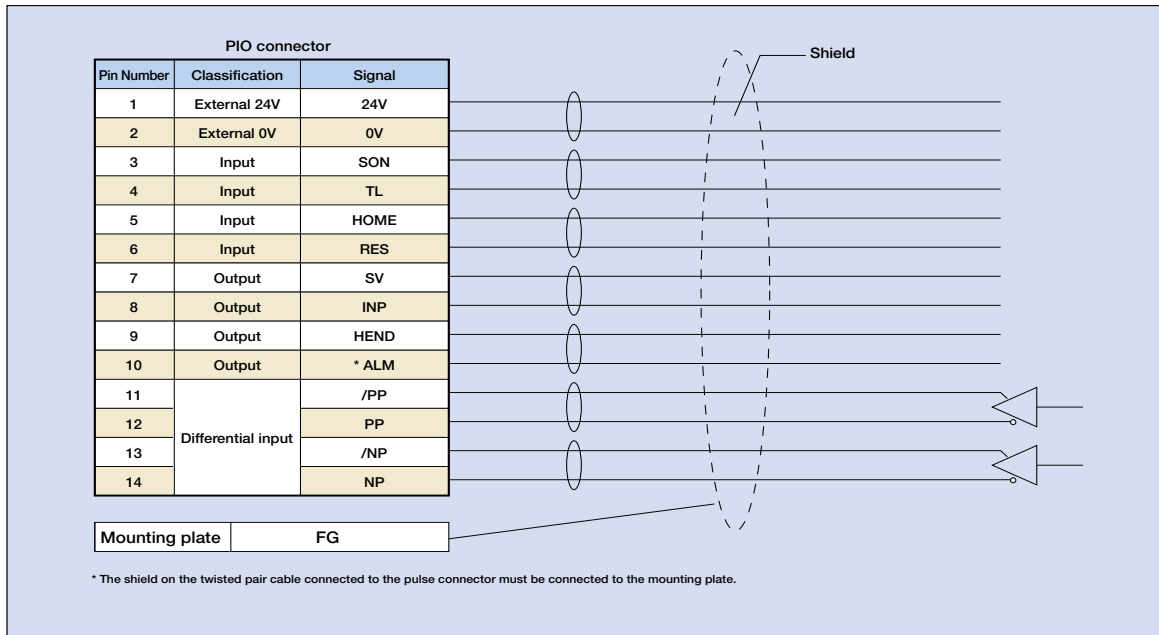

■ Open Collector Method (ACON-PO)

Max. input pulse frequency : Max. 60 kpps  
 Cable Length : Max. 2m

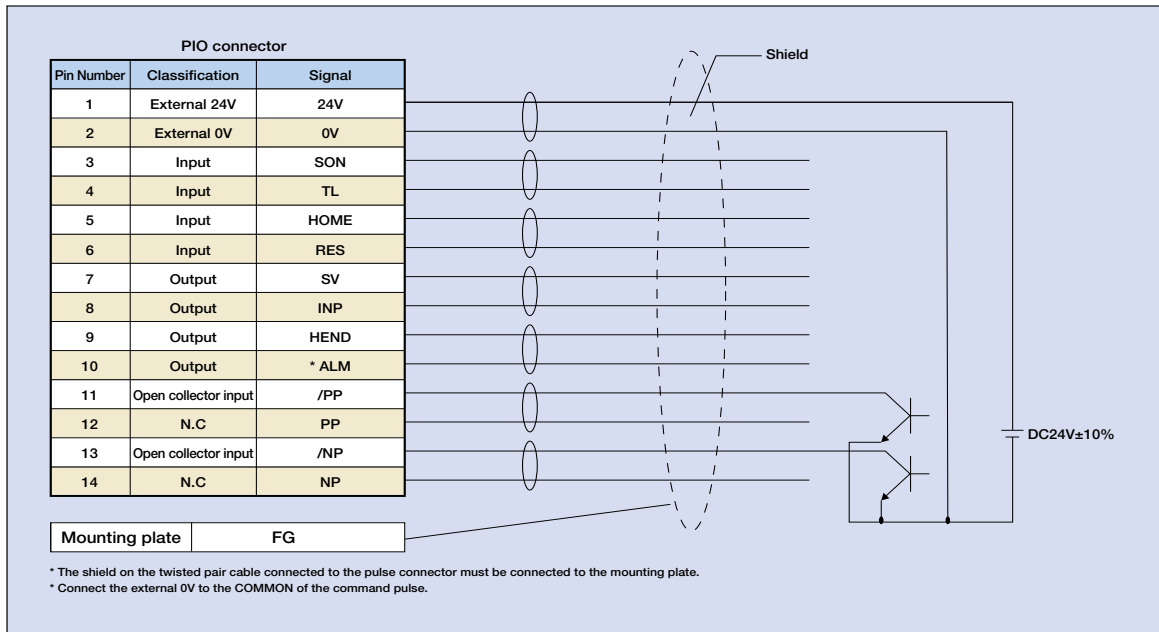

- Slider Type
- Mini
- Standard
- Controllers Integrated
- Pcd Type
- Mini
- Standard
- Controllers Integrated
- Table/Arm /FlatType
- Mini
- Standard
- Gripper/ Rotary Type
- Linear Servo Type
- Cleanroom Type
- Splash-Proo
- Controllers
- PMEC /AMEC
- PSEP /ASEP
- ROBO NET
- ERC2
- PCON
- ACON
- SCON
- PSEL
- ASEL
- SSEL
- XSEL
- Pulse Motor
- Servo Motor (24V)
- Servo Motor (200V)
- Linear Servo Motor

## Command Pulse Input State

Command pulse train state		Input terminal	During forward operation	During reversed operation	
Negative logic	Forward pulse train	PP·/PP			
	Reversed pulse train	NP·/NP			
	The forward pulse train causes the motor to rotate forward, and the reverse pulse train causes the motor to rotate in reverse.				
	Pulse train	PP·/PP			
	Symbols	NP·/NP	Low	High	
	The command pulse is used for the amount of motor rotation, and the command symbol is used for rotational direction.				
Positive logic	A/B phase pulse train	PP·/PP			
		NP·/NP			
	An A/B phase pulse with a 90° phase difference (multiplier is 4) is used to generate commands for the amount of rotation and rotational direction.				
	Forward pulse train	PP·/PP			
	Reversed pulse train	NP·/NP			
	Symbols	NP·/NP	High	Low	
A/B phase pulse train	PP·/PP				
	NP·/NP				

## Table of specifications

Item	Specifications					
Controller type	C	CG	CY	PL	PO	SE
Connected actuator	RCA Series Actuator					
Number of control axes	1-axis					
Operating method	Positioner type		Solenoid valve type	Pulse train input type		Serial communication type
Positioning Points	512 points		3 points	-		64 points
Backup memory	EEPROM					
I/O connector	40-pin connector		12-pin connector	14-pin connector		None
Number of I/O	16 input points/16 output points		4 input points / 6 output points	4 input points/4 output points		None
I/O power	External supply DC24V±10%					
Serial Communication	RS485 1ch					
Peripheral device communication cable	CB-PAC-PIO □□□		CB-PACY-PIO □□□	CB-PACPU-PIO □□□		CB-RCB-CTL002
Command pulse train input method	-			Differential line driver	Open collector	-
Max. input pulse frequency (Note 1)	-			Max. 200 kpps	Max. 60 kpps	-
Position detection method	Incremental encoder					
Drive-source cutoff relay at emergency stop	Integrated		External			
Forced release of electromagnetic brake	Brake release switch ON/OFF		ON/OFF terminal signal inside the power terminal for brake release			
Input Voltage	DC24V ± 10%					
Dielectric strength voltage	DC500V 1MΩ					
Vibration resistance	XYZ directions		10 to 57Hz, One side amplitude: 0.035mm (continuous), 0.075mm (intermittent) 58 to 150 Hz 4.9 m/s <sup>2</sup> (continuous), 9.8 m/s <sup>2</sup> (intermittent)			
Ambient operating temperature	0 ~ 40°C					
Ambient operating humidity	10 - 95% (non-condensing)					
Ambient operating atmosphere	Without corrosive gases					
Protection class	IP20					
Weight	Approx. 300g			Approx. 130g		

(Note 1) With the open collector specification, keep the maximum input frequency to 60 kpps or below to prevent malfunction. For applications exceeding 60kpps, use the differential line driver.

Actuator	Motor	Standard specifications/high acceleration and deceleration model		Power-saving model			
		Rated [A]	Max. [A]	Rated [A]	Max. [A]		
Motor Power Supply Capacity (Note 2)	RCA	10W	1.3	4.4	1.3	2.5	
		20W [Model symbol: 20]	1.3	4.4	1.3	2.5	
		30W	1.3	4.4	1.3	2.2	
	RCA2	20W [Model symbol: 20S] SA4, RA3, TA5 Type dedicated	1.7	5.1	1.7	3.4	
		RCL	2W	0.8	4.6		
			5W	1.0	6.4		
10W	1.3		6.4				

(Note 2) Other than motor power supply capacity, increase 0.5A as control power supply. Inrush current of approx. 5 to 12 times the rated current occurs within 1 to 2 msec from turning the power on. The inrush current changes depending on the power supply line impedance.

# 541

ACON

External Dimensions

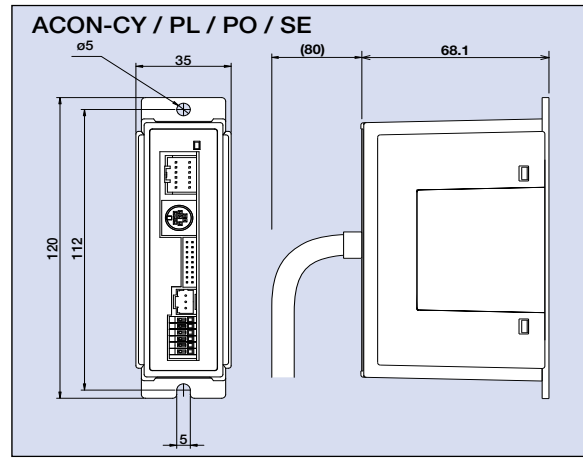
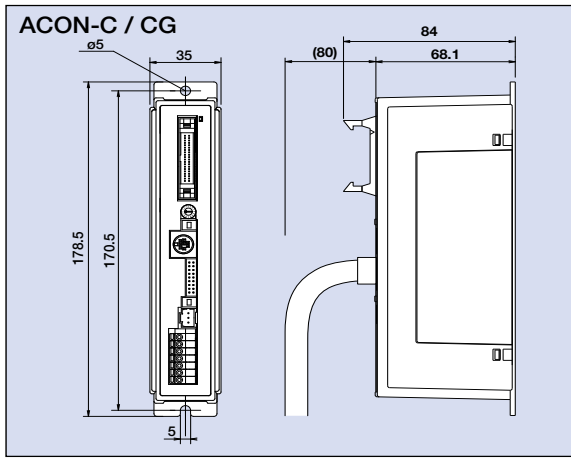

Name of Each Part

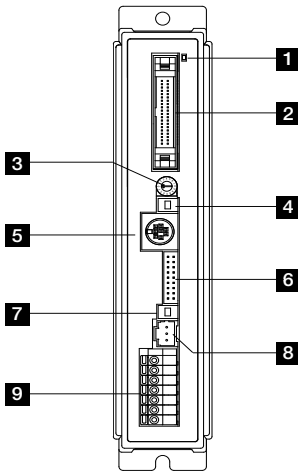

C / CG type

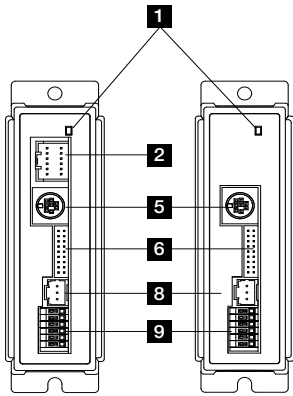

CY / PL / PO Type

SE Type

\* PIO connectors are:  
CY: 12 pin  
PL/PO: 14 pin

**1 LED display**

These LED colors indicate the condition of the controller.

Lit (green) Servo ON    Lit (red) Alarm activated    Unlit Servo OFF    Blinking (green) Automatic servo-OFF  
Emergency stop

**2 PIO connector**

Connects a cable for communicating with a PLC or other external equipment.

**3 Address-setting rotary switch**

This switch sets the addresses for controllers used when the unit is linked with controllers.

**4 Mode switch**

Switches between manual teaching pendant operations (MANU) and automatic operations (AUTO).

Operation details

MANUAL	I/O commands are not accepted. Data can be written from a teaching pendant or PC.
AUTO	I/O commands are valid, while operations from a teaching pendant or PC are not accepted. However, monitoring is possible.

**5 SIO connector**

Connects a teaching pendant, PC cable, controller, or gateway unit to a controller.

Operation details

Pin No.	Signal	Name	Remarks
1	SGA	Positive side, RS485 differential signal	
2	SGB	Negative side, RS485 differential signal	
3	5V	+5V output	For RS232/485 conversion
4	ENBL	Enable signal	
5	EMGA	EMG line connection to external equipment	
6	24V	24-V power for T/P	For T/P
7	0V	GND	
8	EMGB	EMG line connection to external equipment	
9	0V	EMG line connection to external equipment ground	

**6 Encoder brake connector**

Connects the encoder/brake cable for the actuator.

**7 Brake release switch**

This switch forces the brake to release.

**8 Motor connector**

Connects the motor cable for the actuator.

**9 Power terminal block**

Main power for controller(s), emergency stop

C / CG type

Terminal number	Signal	Name
7	S1	External drive-source cutoff for TP_EMG terminal
6	S2	Motor drive-source cutoff terminal
5	MPI	Motor drive-source cutoff terminal
4	MPO	Motor drive-source cutoff terminal
3	24V	Positive side of the 24-V power supply
2	0V	Negative side of the 24-V power supply
1	EMG	EMG signal (application of 24 V)

CY / PL / PO / SE type

Terminal number	Signal	Name
6	BK	BK release
5	MPI	Motor drive-source cutoff terminal
4	MPO	Motor drive-source cutoff terminal
3	24V	Positive side of the 24-V power supply
2	0V	Negative side of the 24-V power supply
1	EMG	EMG signal (application of 24 V)

- Slider Type
- Mini
- Standard
- Controllers Integrated
- Pcd Type
- Mini
- Standard
- Controllers Integrated
- Table/Arm /FlatType
- Mini
- Standard
- Gripper/ Rotary Type
- Linear Servo Type
- Cleanroom Type
- Splash-Proo
- Controllers
- PMEC /AMEC
- PSEP /ASEP
- ROBO NET
- ERC2
- PCON
- ACON
- SCON
- PSEL
- ASEL
- SSEL
- XSEL
- Pulse Motor
- Servo Motor (24V)
- Servo Motor (200V)
- Linear Servo Motor



## Option

### Teaching Pendant

**Features** This is a teaching device that provides information on functions such as position input, performing test runs, and monitoring.

- Model** **CON-PT-M-ENG** (Touch panel teaching pendant)
- CON-T-ENG** (Standard type)
- RCM-E-ENG** (Simple teaching pendant)

**Configuration**

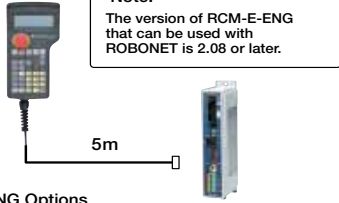

**CON-T-ENG Options**

- Wall-mounting hook Model HK-1
- Strap Model STR-1

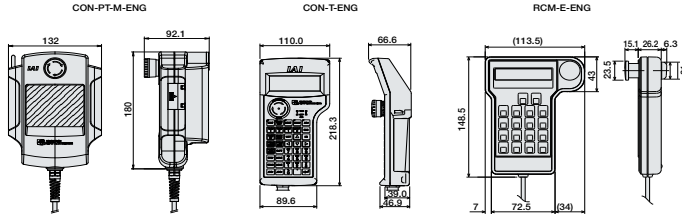

**Specifications**

Item	CON-PT-M-ENG	CON-T-ENG	RCM-E-ENG
Data Input	○	○	○
Actuator motion	○	○	○
Ambient Operating Temp./Humidity	Temp: 0~40°C; Humidity: 85% RH or below		
Ambient Operating Atmosphere	No corrosive gases. Especially no dust.		
Protection class	IP40	IP54	—
Weight	Approx. 750g	Approx. 400g	Approx. 400g
Cable Length	5m		
Display	3-color LED touch panel with backlight	20 char. x 4 lines LCD display	16 char. x 2 lines LCD display

### PC Software (Windows Only)

**Features** A startup support software for inputting positions, performing test runs, and monitoring. With enhancements for adjustment functions, the startup time is shortened.

- Model** **RCM-101-MW** (External device communications cable + RS232 conversion unit)

**Configuration**

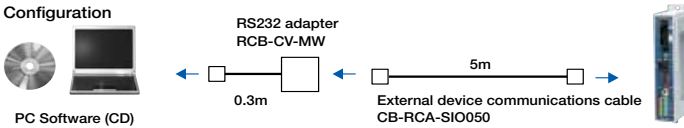

- Model** **RCM-101-USB** (External device communications cable + USB adapter + USB cable)

**Configuration**

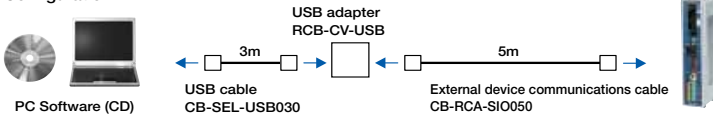

### Spare parts

When you need spare parts after purchasing the product, such as when replacing a cable, refer to the list of models below.

#### Motor Cable for RCA

Model **CB-ACS-MA**

\* Enter the cable length (L) into   . Compatible to a maximum of 20 meters. Ex.: 080 = 8 m

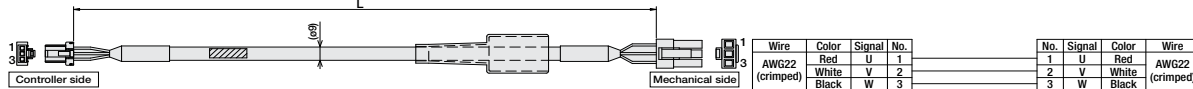

Min. bend radius r = 50 mm or larger (when movable type is used)

# 543

ACON

Encoder Cable / Encoder Robot Cable for RCA

Model **CB-ACS-PA** / **CB-ACS-PA** -**RB**

\* The standard cable for the encoder cable is the normal cable. \* Enter the cable length (L) into . Compatible to a maximum of 20 meters. Ex.: 080 = 8 m

Min. bend radius r = 50 mm or larger (when movable type is used)  
\* Only robot cable is to be used in a cable track.

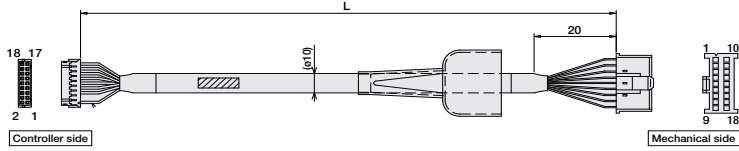

CN2				CN1			
Cable color	Signal	Pin No.	Cable color	Signal	Pin No.	Standard Cable	Robot Cable
White/Purple	Blue	LS+	18	1	ENA	Gray	White/Blue
White/Gray	Orange	LS-	17	2	ENA	Red	White/Yellow
Yellow	Green	BK-	16	3	ENB	Black	White/Red
Blue	Brown	BK-	15	4	ENB	Yellow	White/Black
White/Blue	Gray	ENA	14	5	ENB	White	White/Black
White/Red	Red	ENA	13	6	LS+	Blue	White/Purple
White/Black	Black	ENB	12	7	ENB	Green	White/Black
White/Black	Yellow	ENB	11	8	ENB	Ground	Ground
Orange	Pink	ENZ	10	9	FG	Ground	Ground
Green	Purple	ENZ	9	10	ENZ	Pink	Orange
Purple	White	ENZ	8	11	ENZ	Purple	Green
Gray	Blue/red	VFS	7	12	ENZ	White	Purple
Red	Orange/White	SV	6	13	VFS	Blue/red	Gray
Black	Green/White	GND	5	14	SV	Orange/White	Red
---	---	---	---	15	GND	Green/White	Black
---	---	---	---	16	LS-	Orange	White/Gray
---	---	---	---	17	BK-	Brown	Blue
Ground	Ground	FG	1	18	BK+	Green	Yellow

Housing : PHDR-18VR (JST)  
Contact : SPHD-001T-P0.5 (JST)

Plug housing : XMP-18V (JST)  
Socket contact : EXA-001T-P0.6 (JST)  
Retainer : XMS-09V (JST)

Motor-Encoder Integrated Cable for RCA2

Model **CB-ACS-MPA**

\* The standard cable is a robot cable.

\* Enter the cable length (L) into . Compatible to a maximum of 20 meters. Ex.: 080 = 8 m

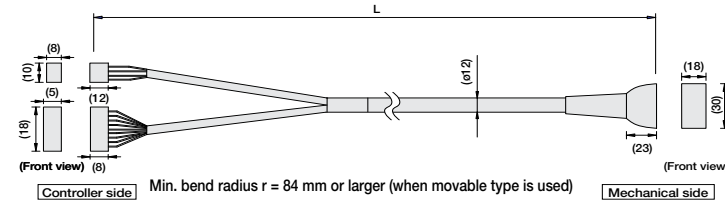

Signal	Pin No.	(Wire color)	Pin No.	Signal
U	1	Red	A1	U
V	2	Yellow	B1	V
W	3	Black	A2	W
			A3	NC
			A4	NC
			A5	NC
			A6	NC
			A7	NC
			A8	NC
			A9	NC
			A10	NC
			A11	NC
			A12	NC
			A13	NC
			A14	NC
			A15	NC
			A16	NC
			A17	NC
			A18	NC
			A19	NC
			A20	NC
			A21	NC
			A22	NC
			A23	NC
			A24	NC
			A25	NC
			A26	NC
			A27	NC
			A28	NC
			A29	NC
			A30	NC
			A31	NC
			A32	NC
			A33	NC
			A34	NC
			A35	NC
			A36	NC
			A37	NC
			A38	NC
			A39	NC
			A40	NC
			A41	NC
			A42	NC
			A43	NC
			A44	NC
			A45	NC
			A46	NC
			A47	NC
			A48	NC
			A49	NC
			A50	NC
			A51	NC
			A52	NC
			A53	NC
			A54	NC
			A55	NC
			A56	NC
			A57	NC
			A58	NC
			A59	NC
			A60	NC
			A61	NC
			A62	NC
			A63	NC
			A64	NC
			A65	NC
			A66	NC
			A67	NC
			A68	NC
			A69	NC
			A70	NC
			A71	NC
			A72	NC
			A73	NC
			A74	NC
			A75	NC
			A76	NC
			A77	NC
			A78	NC
			A79	NC
			A80	NC
			A81	NC
			A82	NC
			A83	NC
			A84	NC
			A85	NC
			A86	NC
			A87	NC
			A88	NC
			A89	NC
			A90	NC
			A91	NC
			A92	NC
			A93	NC
			A94	NC
			A95	NC
			A96	NC
			A97	NC
			A98	NC
			A99	NC
			A100	NC

I/O Flat Cable (for ACON-C / CG)

Model **CB-PAC-PIO**

\* Enter the cable length (L) into . Compatible to a maximum of 10 meters. Ex.: 080 = 8 m

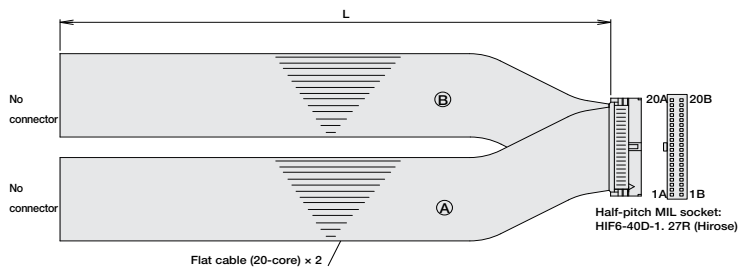

Pin No.	Signal	Cable Color	Wire	Pin No.	Signal	Cable Color	Wire
1A	24V	Brown-1		1B	OUT0	Brown-3	
2A	24V	Red-1		2B	OUT1	Red-3	
3A	---	Orange-1		3B	OUT2	Orange-3	
4A	---	Yellow-1		4B	OUT3	Yellow-3	
5A	IN0	Green-1		5B	OUT4	Green-3	
6A	IN1	Blue-1		6B	OUT5	Blue-3	
7A	IN2	Purple-1		7B	OUT6	Purple-3	
8A	IN3	Gray-1		8B	OUT7	Gray-3	
9A	IN4	White-1		9B	OUT8	White-3	
10A	IN5	Black-1		10B	OUT9	Black-3	
11A	IN6	Brown-2		11B	OUT10	Brown-4	
12A	IN7	Red-2		12B	OUT11	Red-4	
13A	IN8	Orange-2		13B	OUT12	Orange-4	
14A	IN9	Yellow-2		14B	OUT13	Yellow-4	
15A	IN10	Green-2		15B	OUT14	Green-4	
16A	IN11	Blue-2		16B	OUT15	Blue-4	
17A	IN12	Purple-2		17B	---	Purple-4	
18A	IN13	Gray-2		18B	---	Gray-4	
19A	IN14	White-2		19B	OV	White-4	
20A	IN15	Black-2		20B	OV	Black-4	

I/O Cable for Solenoid Valve Type (for ACON-CY)

Model **CB-PACY-PIO**

\* Enter the cable length (L) into . Compatible to a maximum of 10 meters. Ex.: 080 = 8 m

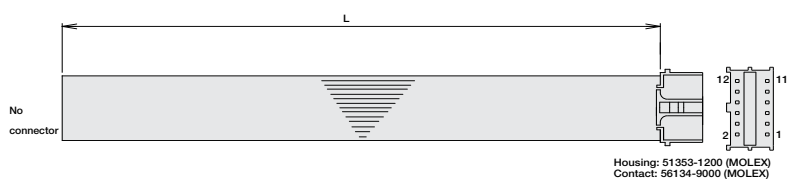

Pin No.	Signal	Cable Color	Wire
1	24V	Brown-1	
2	OV	Red-1	
3	IN0	Orange-1	
4	IN1	Yellow-1	
5	IN2	Green-1	
6	IN3	Blue-1	
7	OUT0	Purple-1	
8	OUT1	Gray-1	
9	OUT2	White-1	
10	OUT3	Black-1	
11	OUT4	Brown-2	
12	OUT5	Red-2	

Pulse Train Control I/O Cable (for ACON-PL/PO)

Model **CB-PACPU-PIO**

\* Enter the cable length (L) into . Compatible to a maximum of 10 meters. Ex.: 080 = 8 m

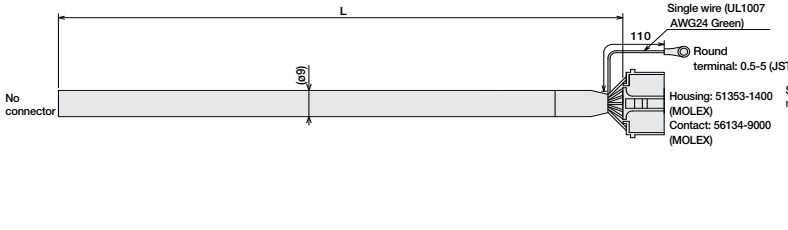

No.	Signal Name	Cable Color	Wire
1	IO 24V	Black	
2	IO 24V	White/Black	
3	IN0	Red	
4	IN1	White/Red	
5	IN2	Green	
6	IN3	White/Green	
7	OUT0	Yellow	
8	OUT1	White/Yellow	
9	OUT2	Brown	
10	OUT3	White/Brown	
11	PP	Blue	
12	PG	White/Blue	
13	NP	Gray	
14	NG	White/Gray	
1	FG	White/Gray	AWG24

- Slider Type
- Mini
- Standard
- Controllers Integrated
- Fcd Type
- Mini
- Standard
- Controllers Integrated
- Table/Arm /FlatType
- Mini
- Standard
- Controllers Integrated
- Gripper/Mini Rotary Type
- Linear Servo Type
- Cleanroom Type
- Splash-Proof
- Controllers
- PMEC /AMEC
- PSEP /ASEP
- ROBO NET
- ERC2
- PCON
- ACON
- SCON
- PSEL
- ASEL
- SSEL
- XSEL
- Pulse Motor
- Servo Motor (24V)
- Servo Motor (200V)
- Linear Servo Motor