

H I G H P R E C I S I O N

Gear Reducers

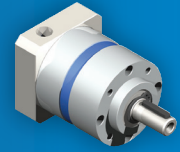

Couplings &

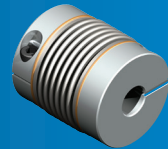

Linear Mount Products

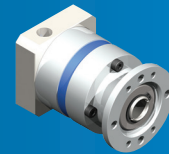

GAM

GAM CAN.

Sold & Serviced By:

 **ELECTROMATE**

Toll Free Phone (877) SERV098

Toll Free Fax (877) SERV099

www.electromate.com

sales@electromate.com



Company Overview	3-4
Product Selection Guides	5-6
In-Line Gear Reducers	7-48
Highest Performance	
SPH Series: SPH-W, SPH-K, SPH-F	7-14
SPL Series: SPL-W, SPL-K, SPL-F	15-22
High Performance	
EPL Series: EPL-W, EPL-X, EPL-A, EPL-F, EPL-H	23-34
Stainless Steel Series: SSP-W	35-38
FP Series: FP-FB, FP-P, FP-F	39-42
Performance	
PE Series: PE-W, PE-N (NEMA)	43-48
Right-Angle Gear Reducers	49-76
Highest Performance	
Dyna Series: DS-W, DS-H, DS-T, DS-F	49-54
High Performance	
Dyna-Lite Series: DL-DW, DL-DH, DL-PW, DL-PH	55-60
Performance	
Spiral Bevel Series: V, L, VC, LL	61-76
Linear Mount Products	77-82
Performance	
Linear Slide Kit: LSK	79-80
Parallel Mount Kit: PMK	81-82
Couplings	83-98
Bellows Couplings	
KM Series	87
KP Series	88
KLC Series	89
KG Series	90
Elastomer Couplings	
EKC Series:	91
EKM Series	92
Distance Couplings	
WDS Series	93
EDC Series	94
Safety Couplings	
SKB Series: SKB-KP, SKB-EK, SKB	95-97
SKG Series	98
Sizing Information	99-100
Additional Products	101

Sold & Serviced By:



Toll Free Phone (877) SERV098
Toll Free Fax (877) SERV099
www.electromate.com
sales@electromate.com



▶ COMPANY OVERVIEW

GAM is your complete source for Gear Reducers, Servo Couplings, Linear Mounting Kits, and other innovative products used in automation technology.

With one of the largest product offerings in the motion control industry as well as the engineering expertise and manufacturing capabilities to develop customized solutions, GAM can help with your application.

Being flexible to meet the needs of customer requests and great service are what set us apart from the rest.

GAM Can.

- 1** We are flexible! We will modify our products or tailor our services to meet your needs. GAM Can, Just Ask!
- 2** Quick delivery on the standard products marked in our literature.
- 3** 24-Hour a day emergency service and same day delivery available.
- 4** Excellent technical assistance from our inside application engineers and trained network of outside sales engineers.
- 5** Immediate 2-D drawings or 3-D models configured on-line.
- 6** 100% inspection and quality control on every gearbox shipped from GAM.
- 7** Lean manufacturing procedures used to ensure our products are produced cost effectively.
- 8** Largest product range of precision gearboxes for motion control applications.
- 9** U.S. owned. Our roots date back to the early 1950s.
- 10** We have a great team at GAM. We will listen to you and we promise to do our very best to respond to your needs.



Sold & Serviced By
 **ELECTROMATE**

Toll Free Phone (877) SERV098
Toll Free Fax (877) SERV099
www.electromate.com
sales@electromate.com

Can't Find What You Are Looking For? Just Ask GAM!

GAM's product range is among the broadest, if not the broadest, on the market for precision gearboxes. Even with such a broad product range, we realize that you may not find a gearbox that meets your exact requirements.

One of our strengths is our ability to customize standard designs to meet special needs. And, because of our flexible manufacturing, we can cost-effectively produce small batches of customized product in short time frames. So if you can't find what you are looking for, just ask GAM. Here are a few specials we have done for customers in the past:

- Special output shaft dimensions
- Custom output shaft features
- Stainless steel shaft
- Pinion gear assembly on output
- Special color of gearbox
- Steel-it paint on gearbox
- Anodized gearbox housing
- Custom output face on the gearbox
- Drop-in replacement for other gearboxes
- Special input clamping style (spline, set-screw, other)
- Special grease or oil
- Special bearings to modify gearbox ratings
- Special backlash
- Special housing design
- Vacuum environment gearbox
- Speed increasers
- Foot mounts
- Special mounting hardware
- Plastic gears
- Special gear ratios

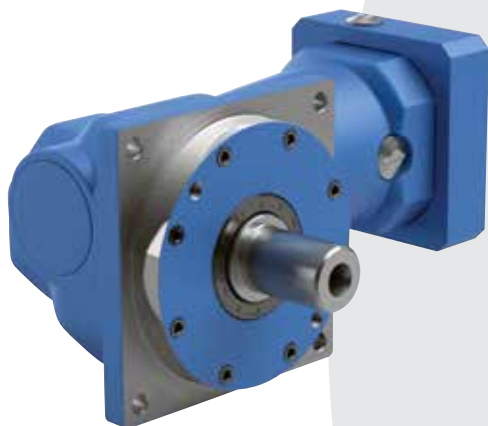

Standard Dyna-Lite Hypoid Gear Reducer



Modified Dyna-Lite for Washdown Applications

DISCLAIMER

The information in this catalog is correct at the time of print. However, we are continuously updating and developing our products and reserve the right to make changes to the dimensions and specifications. For the most up to date information, please visit www.gamweb.com

Sold & Serviced By:



ELECTROMATE

Toll Free Phone (877) SERV098

Toll Free Fax (877) SERV099

www.electromate.com

sales@electromate.com



▶ PRODUCT SELECTION GUIDE CHART

Gear Reducer Selection Guide

		Inline Planetary Gear Reducers					
		Highest Performance		High Performance	Performance	Specialty High Performance	
		SPH	SPL	EPL	PE	FP	SSP (Stainless)
Gear Technology		Helical	Straight Tooth	Straight Tooth	Straight Tooth	Straight Tooth	Straight Tooth
Ratios	min	3	3	3	3	4	3
	max	100	100	1000	1000	91	100
Frame Sizes		6	5	5	4	4	3
Max. Nominal Torque (Nm)		900	600	340	210	210	210
Lowest Backlash (arcmin)		<2	<2	<8	<8	<5	<8
Max. Radial Loading (N)		20000	13000	7500	2500	6541	3000
Service Life (hrs)		20000	30000	30000	20000	20000	30000
Output Style	Shaft (Metric)						
	Shaft (NEMA)						
	Hollow						
	Flange						
		Right Angle Gear Reducers					
		Highest Performance	High Performance	Performance		Specialty Performance	
		DYNA*	DL	VC	V	LL/L	
Gear Technology		Hypoid	Hypoid	Spiral Bevel	Spiral Bevel	Mini Spiral Bevel	
Ratios	min	3	5	1	1	1	
	max	100	150	6	6	4	
Frame Sizes		6	3	6	9	2	
Max. Nominal Torque (Nm)		1400	140	472	4640	9	
Lowest Backlash (arcmin)		<2*	<8	<8	<20	<15	
Max. Radial Loading (N)		15000	7200	8000	34200	-	
Service Life (hrs)		30000	15000	15000	15000	10000	
Output Style	Single Shaft						
	Multiple Shafts						
	Hollow						
	Flange						

Sold & Serviced By:



Toll Free Phone (877) SERV098

























Toll Free Fax (877) SERV099

www.electromate.com

sales@electromate.com

*DSX option - Ground Gears / Improved Performance / Lowest Backlash

Couplings Selection Guide





		Max Torque Range					
		High (3,000 Nm - 1,500 Nm)		Medium (1,300 Nm - 550 Nm)		Low (125 Nm - 110 Nm)	
		Bellows Couplings	Elastomer Couplings	Bellows Couplings	Elastomer Couplings	Bellows Couplings	Elastomer Couplings
Standard Couplings	All Purpose	KM* 		KP*  KG* 	EKM 		
	Low Cost					KLC 	EKC 
Specialty Couplings	High Speed			KHS 	ESM-A 		
	Stainless Steel			KG-VA* 			
	High Torque	KSD 					
	High Torsional Stiffness	KSS  KR* 					
	For easy Installation	KGH 		KPP*  KPS* 			
Distance Couplings	For easy Installation	WDS 			EKZ 		
	Low Cost						EDC 
Safety Couplings	Direct Drive	Radial Clamp	SKB-KP* 		SKB-EK 		
		Conical Clamp	SKY-KS 		SKY-ES 		
	Indirect Drive	Radial Clamp	SKB 		SKX-L 		
		Conical Clamp			SKG 		

All GAM couplings are zero backlash, low inertia, and compensate for shaft misalignments
 Bellows couplings - Torsionally Stiff - Temperatures up to 300°C
 Elastomer couplings - Provide Vibration / Resonance Dampening - Temperatures up to 120°C

 Couplings available same day

*EASY Clamp system for easy install / unstick

Linear Mount Selection Guide

	Inline	Parallel
Mounting Kits	LSK 	PMK 
Gear Reducers	EPL-H* 	Sold & Serviced By: 

*Note - Right angle options are available - Contact GAM

Toll Free Phone (877) SERV098
 Toll Free Fax (877) SERV099
www.electromate.com
sales@electromate.com



▶ HIGHEST PERFORMANCE: SPH SERIES

The SPH series features helical gearing which brings a whole new level of power and precision to GAM's already extensive portfolio of gear reducer technology. With special attention paid to every aspect during development, the SPH gracefully combines design and engineering, to deliver our best inline planetary gear reducer yet. For dynamic and demanding servo applications where performance is critical, the SPH is highly powerful and efficient, yet smooth and quiet.

- 1. Helical Gears** Precision cut and ground to quietly deliver higher torques and accuracies
- 2. Adapter Flange** Custom machined to match any motor for easy installation
- 3. Input Clamping Element** Low inertia and balanced for high speeds with a single tangential screw ensures a secure motor connection
- 4. Bearings** Optimized taper roller bearings to accommodate high radial and axial loads
- 5. Housing** Sleek and contoured steel housing with black oxide treatment for maximum durability
- 6. Ring Gear** Machined directly into the single piece housing for maximum stiffness
- 7. Output Shaft** Offered smooth or keyed and can be easily shortened if required

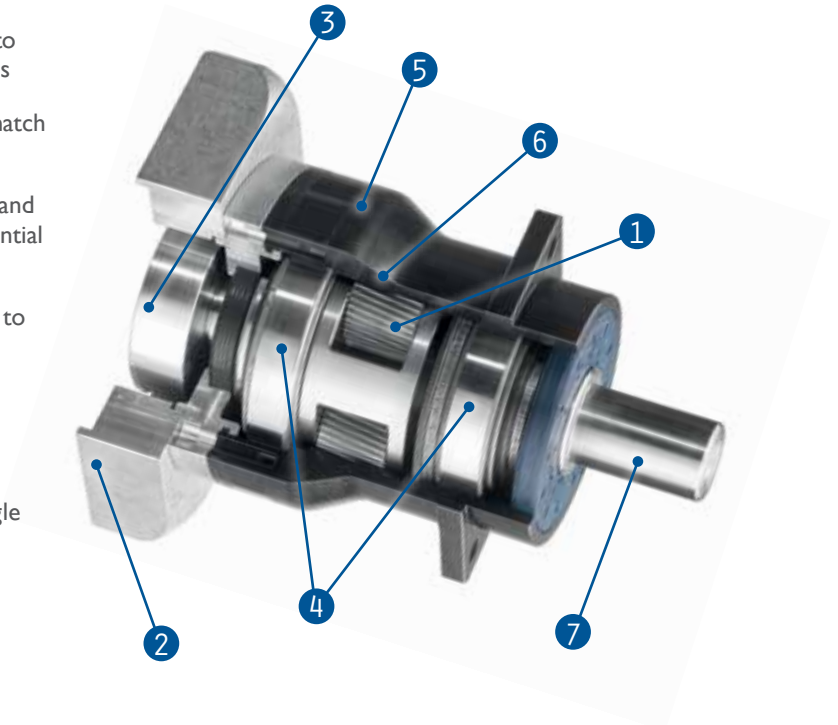

Helical gears make the difference

The helical gear profile is cut at an angle that allows for gradual tooth engagement allowing for smooth, accurate, and quiet transmission. GAM's SPH gears are cut at the optimal helix angle to minimize resultant axial forces and they have a larger tooth width to maximize torque carrying capacity compared to the competition.

It all starts with the gears

The SPH's helical gears are produced to an extremely high level of quality and ground for further precision. With state of the art testing and measuring instruments and qualified personnel, we assure that the SPH will meet and exceed your requirements. With the SPH, every detail counts.

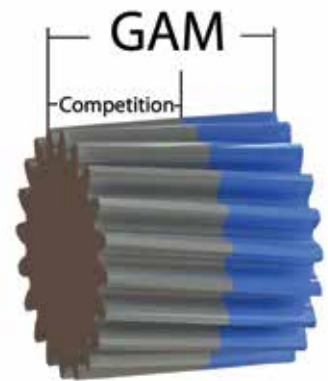

The SPH is GAM's highest performing inline gear reducer

Designed for **dynamic**
& **cyclic** applications

Can be optimized for **high speed**
and **continuous** applications

Sold & Serviced By:

 **ELECTROMATE**

Toll Free Phone (877) SERV098
Toll Free Fax (877) SERV099
www.electromate.com
sales@electromate.com

Available configurations for simple and compact machine integration



SPH-W

Shaft output design for mounting to pulleys and rack and pinion systems. Available with a smooth or keyed output shaft.

SPH-K

Features a bellows or a zero backlash elastomer-spider coupling on the output for maximum stiffness and the best results in highly dynamic applications. An output housing comes standard with custom housings available.

SPH-F

Same benefits as the SPH-K models without the housing on the output. Plug the gearbox directly into your machine and achieve a more compact design.

When your application is demanding...demand GAM's SPH

	LOW	HIGH	SUPERIOR	WHY GAM SPH?
Flexibility	Competition A		SPH	Configured to meet the application, not the other way around!
	Competition B			
Modifications & Customizations	Competition A		SPH	Flexible manufacturing and experienced engineering
	Competition B			
Performance			SPH	95 years of gear manufacturing experience
			Competition A	
			Competition B	
Quality			SPH	State of the art testing and measuring machines. ISO 9001 Certified
			Competition A	
			Competition B	



The following methods are applied:

- CNC coordinate measurement method
- CNC gear measurement method
- Mechanical measurement test
- Surface testing
- Thickness measurement
- Magnetic particle inspection
- Hardness testing
- Grinding burn inspection

Sold & Serviced By:

 **ELECTROMATE**

Toll Free Phone (877) SERV098

Toll Free Fax (877) SERV099

www.electromate.com

sales@electromate.com



HIGHEST PERFORMANCE: SPH SERIES - SPH-W

SPH-W		50	60	75	100	140	180	
All Ratios Available		1 Stage: 3, 4, 5, 7, 10						
		2 Stage: 12, 15, 16, 20, 25, 28, 30, 35, 40, 50, 70, 100						
Nominal Output Torque (T_{2n})	Nm (lb-in)	3:1-5:1	20 (177)	60 (531)	100 (885)	250 (2213)	450 (3983)	900 (7966)
		7:1	18 (159)	40 (354)	80 (708)	180 (1593)	420 (3717)	800 (7081)
		10:1	15 (133)	30 (266)	65 (575)	110 (974)	240 (2124)	450 (3983)
		12:1-40:1	13 (115)	60 (531)	100 (885)	250 (2213)	450 (3983)	900 (7966)
		50:1	13 (115)	40 (354)	80 (708)	250 (2213)	450 (3983)	900 (7966)
		70:1	10 (89)	40 (354)	80 (708)	180 (1593)	420 (3717)	800 (7081)
	100:1	7 (62)	30 (266)	65 (575)	110 (974)	240 (2124)	450 (3983)	
Max Acceleration Output Torque (T_{2B})	Nm (lb-in)	1.5 x Nominal (T_{2n})						
Emergency Output Torque (T_{2not})	Nm (lb-in)	3.5 x Nominal (T_{2n})						
Nominal Input Speed (n_{1n})	RPM	-	4500	4500	4500	4000	3800	2000
Max Input Speed (n_{1max})		-	6000					
Standard Output Backlash (j)	arcmin	1-stage	<4	<4	<4	<4	<4	<4
		2-stage	<6	<6	<6	<6	<6	<6
Reduced Output Backlash (j)	arcmin	1-stage	<3	<2	<2	<2	<2	<2
		2-stage	<5	<4	<4	<4	<4	<4
Allowable Radial Load (F_{rad})1)	N (lbf)	-	700 (157)	3,500 (787)	4,500 (1012)	8,000 (1798)	12,000 (2698)	20,000 (4496)
Allowable Axial Load (F_{axial})	N (lbf)	-	600 (135)	1,600 (360)	2,400 (540)	2,400 (540)	6,000 (1349)	10,000 (2248)
Torsional Stiffness (C_{t21})	Nm/arcmin (lb-in/arcmin)	1-stage	2.0 (18)	4.0 (35)	12 (106)	32 (283)	54 (478)	168 (1487)
		2-stage	2.0 (18)	4.0 (35)	12 (106)	32 (283)	54 (478)	168 (1487)
Mass Moment of Inertia (J_1)	kg-cm ² (lb-in ²)	3:1	0.13 (0.044)	0.42 (0.144)	1.26 (0.431)	4.00 (1.367)	12.90 (4.408)	62.30 (21.29)
		4:1	0.08 (0.027)	0.29 (0.099)	0.95 (0.325)	2.90 (0.991)	8.45 (2.888)	38.90 (13.29)
		5:1	0.06 (0.021)	0.22 (0.075)	0.79 (0.270)	2.20 (0.752)	6.20 (2.119)	25.90 (8.850)
		7:1	0.05 (0.017)	0.17 (0.058)	0.68 (0.232)	1.81 (0.619)	4.66 (1.592)	18.40 (6.288)
		10:1	0.04 (0.014)	0.15 (0.051)	0.62 (0.212)	1.60 (0.547)	3.86 (1.319)	13.60 (4.647)
		12-16:1	0.08 (0.027)	0.18 (0.062)	0.62 (0.212)	1.46 (0.499)	3.40 (1.162)	12.90 (4.408)
		20-25:1	0.06 (0.021)	0.14 (0.048)	0.53 (0.181)	1.20 (0.410)	2.45 (0.837)	8.69 (2.970)
		28-40:1	0.05 (0.017)	0.13 (0.044)	0.50 (0.171)	1.10 (0.376)	2.10 (0.718)	6.99 (2.389)
		50-100:1	0.04 (0.014)	0.12 (0.041)	0.46 (0.157)	0.99 (0.338)	1.73 (0.591)	5.39 (1.842)
Weight (m)	kg (lbs)	1-stage	1.1 (2.4)	(2.2) (4.9)	3.6 (7.9)	7.3 (16)	17.4 (38)	38 (84)
		2-stage	1.8 (4.0)	(2.9) (6.4)	4.9 (11)	9.1 (20)	23.3 (51)	48 (106)
Noise Level (L_{pk})	dB(A)	1-stage	<60	<60	<63	<64	<65	<65
		2-stage	<60	<60	<61	<62	<63	<64
Efficiency at Load	1-stage: 98% 2-stage: 96%							
Service Life	>20,000 hours							
Lubrication	Lifetime lubrication with synthetic oil							
Protection Rating	IP64 (IP65/IP66 available on request)							
Operating Temperature Range	-25°C to +80°C (short term: 100°C)							

1) Load applied at center of output shaft @ 100 RPM

Sold & Serviced By:
ELECTROMATE
 Toll Free Phone (877) SERV098
 Toll Free Fax (877) SERV099
www.electromate.com
sales@electromate.com

SPH-W

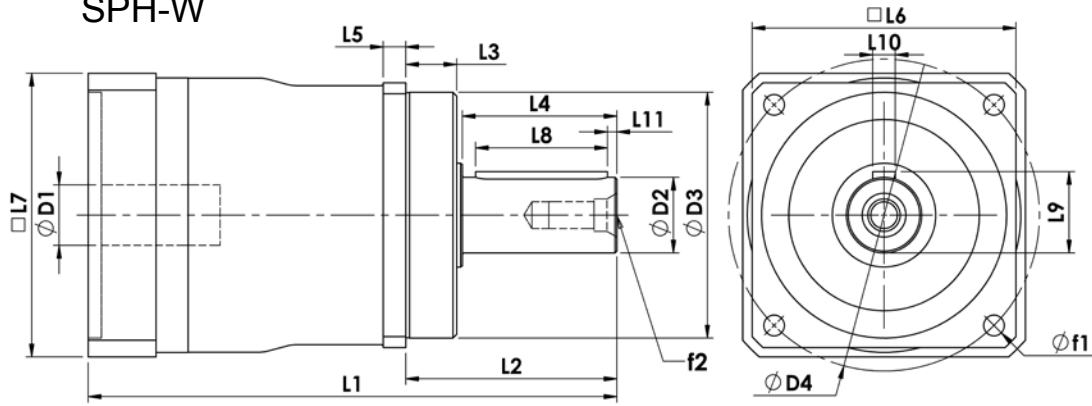

SPH-W		50		60		75		100		140		180	
		mm	(in)	mm	(in)	mm	(in)	mm	(in)	mm	(in)	mm	(in)
D1 _{max} Standard	Motor Shaft Diameter	11	(0.433)	14	(0.551)	19	(0.748)	24	(0.945)	32	(1.260)	38	(1.496)
D1 _{max} Available ¹		11	(0.433)	19	(0.748)	24	(0.945)	32	(1.260)	38	(1.496)	48	(1.890)
D1 _{max} 2-stage		11	(0.433)	14	(0.551)	19	(0.748)	24	(0.945)	32	(1.260)	38	(1.496)
D2 k6	Output Shaft Diameter	14	(0.551)	16	(0.630)	22	(0.866)	32	(1.260)	40	(1.575)	55	(2.165)
D3 g6	Pilot Diameter	45	(1.772)	60	(2.362)	70	(2.756)	90	(3.543)	130	(5.118)	160	(6.299)
D4	Output Bolt Circle	63	(2.480)	68	(2.677)	85	(3.346)	120	(4.724)	165	(6.496)	215	(8.465)
f1	Mounting Holes	5.5	(0.217)	6	(0.236)	6.6	(0.260)	9	(0.354)	11	(0.433)	13	(0.512)
f2	Shaft End Thread	M5		M5		M8		M8		M16		M20	
L1 ²	Overall Gearbox Length	125	(4.921)	150	(5.906)	165	(6.496)	220	(8.661)	280	(11.024)	330	(12.992)
L1 _{2-stage} ²		165	(6.496)	190	(7.480)	210	(8.268)	270	(10.630)	345	(13.583)	420	(16.535)
L2	Shaft Length	38	(1.496)	48	(1.890)	56	(2.205)	88	(3.465)	112	(4.409)	112	(4.409)
L3	Pilot Height	12	(0.472)	18	(0.709)	18	(0.709)	28	(1.102)	27	(1.063)	27	(1.063)
L4	Usable Shaft Length	24	(0.945)	28	(1.102)	36	(1.417)	58	(2.283)	82	(3.228)	82	(3.228)
L5	Flange Thickness	6	(0.236)	6	(0.236)	7	(0.276)	10	(0.394)	12	(0.472)	18	(0.709)
L6	Output Square	55	(2.165)	61	(2.402)	75	(2.953)	100	(3.937)	140	(5.512)	180	(7.087)
L7 ²	Input Square	65	(2.559)	75	(2.953)	90	(3.543)	120	(4.724)	150	(5.906)	210	(8.268)
L8	Key Length	20	(0.787)	25	(0.984)	32	(1.260)	50	(1.969)	70	(2.756)	70	(2.756)
L9	Key Height	16	(0.630)	18	(0.709)	24.5	(0.965)	35	(1.378)	43	(1.693)	59	(2.323)
L10	Key Width	5	(0.197)	5	(0.197)	6	(0.236)	10	(0.394)	12	(0.472)	16	(0.630)
L11	Key End	2	(0.079)	1.5	(0.059)	2	(0.079)	4	(0.157)	5	(0.197)	6	(0.236)

1) For larger motor shaft diameters, please contact GAM.

2) Depending on the motor, value can vary.

TYPE CODES FOR SPL SERIES (SPH-W)

Example: SPH - W - 075 - 005 G - [115 - A01] - S111

Gearbox Series

SPL Series

Gearbox Style

W = Output Shaft

Gearbox Size

050, 060, 075, 100, 140, 180

Ratio

3, 4, 5, 7, 10, 12, 15, 16, 20, 25, 28, 30, 35, 40, 50, 70, 100

Special Options

Assigned by GAM

Motor Mount Kit

Assigned by GAM

Options Available for This Product

G = Key on output shaft per DIN6885

C = Reduced backlash and key on output shaft

H = Smooth output shaft

A = Reduced backlash and smooth shaft

Tolerance (mm)		
Size	k6	g6
Over 6	+0.010	-0.005
Thru 10	+0.001	-0.014
Over 10	+0.012	-0.006
Thru 18	+0.001	-0.017
Over 18	+0.015	-0.007
Thru 30	+0.002	-0.020
Over 30	+0.018	-0.009
Thru 50	+0.002	-0.025
Over 50	+0.021	-0.010
Thru 80	+0.002	-0.029
Over 80	+0.025	-0.012
Thru 120	+0.003	-0.034
Over 120	+0.028	-0.014
Thru 180	+0.003	-0.037

Sold & Serviced By:

ELECTROMATE

Toll Free Phone (877) SERV098

Toll Free Fax (877) SERV099

www.electromate.com

sales@electromate.com



HIGHEST PERFORMANCE: SPH SERIES - SPH-K

SPH-K		50	60	75	100	140	180	
All Ratios Available		1 Stage: 3, 4, 5, 7, 10						
		2 Stage: 12, 15, 16, 20, 25, 28, 30, 35, 40, 50, 70, 100						
Nominal Output Torque (T_{2n})	Nm (lb-in)	3:1-5:1	20 (177)	60 ₁ (531)	100 (885)	250 (2213)	450 (3983)	900 (7966)
		7:1	18 (159)	40 (354)	80 (708)	180 (1593)	420 (3717)	800 (7081)
		10:1	15 (133)	30 (266)	65 (575)	110 (974)	240 (2124)	450 (3983)
		12:1-40:1	13 (115)	60 ₁ (531)	100 (885)	250 (2213)	450 (3983)	900 (7966)
		50:1	13 (115)	40 (354)	80 (708)	250 (2213)	450 (3983)	900 (7966)
		70:1	10 (89)	40 (354)	80 (708)	180 (1593)	420 (3717)	800 (7081)
100:1	7 (62)	30 (266)	65 (575)	110 (974)	240 (2124)	450 (3983)		
Max Acceleration Output Torque (T_{2B})	Nm (lb-in)	1.5 x Nominal (T_{2n})						
Emergency Output Torque (T_{2not})	Nm (lb-in)	3.5 x Nominal (T_{2n})						
Nominal Input Speed (n_{in})	RPM	-	4500	4500	4500	4000	3800	2000
Max Input Speed (n_{1max})		-	6000					
Standard Output Backlash (j)	arcmin	1-stage	<4	<4	<4	<4	<4	<4
		2-stage	<6	<6	<6	<6	<6	<6
Reduced Output Backlash (j)	arcmin	1-stage	<3	<2	<2	<2	<2	<2
		2-stage	<5	<4	<4	<4	<4	<4
Torsional Stiffness (C_{t21}) With Bellows Coupling	Nm/arcmin (lb-in/arcmin)	1-stage	1.3 (11)	2.8 (25)	7.5 (66)	20 (175)	36 (317)	96 (851)
		2-stage	1.3 (11)	2.8 (25)	7.5 (66)	20 (175)	36 (317)	96 (851)
Torsional Stiffness (C_{t21}) With Elastomer Coupling	Nm/arcmin (lb-in/arcmin)	1-stage	0.3 (3)	0.5 (4)	1.0 (9)	3 (23)	5 (46)	11 (99)
		2-stage	0.3 (3)	0.5 (4)	1.0 (9)	3 (23)	5 (46)	11 (99)
Mass Moment of Inertia (J_1) With Bellows Coupling	kg-cm ² (lb-in ²)	3:1	0.18 (0.061)	0.62 (0.212)	1.65 (0.563)	6.89 (2.354)	18.90 (6.458)	89.86 (30.705)
		4:1	0.11 (0.037)	0.40 (0.138)	1.17 (0.399)	4.53 (1.546)	11.83 (4.041)	54.40 (18.589)
		5:1	0.08 (0.027)	0.29 (0.100)	0.93 (0.318)	3.24 (1.107)	8.36 (2.857)	35.82 (12.240)
		7:1	0.06 (0.020)	0.21 (0.071)	0.75 (0.257)	2.34 (0.800)	5.76 (1.969)	23.46 (8.017)
		10:1	0.04 (0.015)	0.17 (0.057)	0.66 (0.224)	1.86 (0.636)	4.40 (1.504)	16.08 (5.495)
		12-16:1	0.08 (0.028)	0.19 (0.064)	0.63 (0.217)	1.56 (0.534)	3.61 (1.234)	13.87 (4.739)
		20-25:1	0.06 (0.021)	0.14 (0.049)	0.54 (0.183)	1.24 (0.424)	2.54 (0.867)	9.09 (3.105)
		28-40:1	0.05 (0.017)	0.13 (0.045)	0.50 (0.172)	1.12 (0.383)	2.14 (0.733)	7.19 (2.458)
Mass Moment of Inertia (J_1) With Elastomer Coupling	kg-cm ² (lb-in ²)	3:1	0.16 (0.056)	0.52 (0.178)	1.68 (0.575)	5.11 (1.747)	15.34 (5.243)	68.08 (23.26)
		4:1	0.10 (0.034)	0.35 (0.118)	1.19 (0.406)	3.53 (1.205)	9.83 (3.357)	42.15 (14.403)
		5:1	0.07 (0.025)	0.26 (0.087)	0.94 (0.322)	2.60 (0.888)	7.08 (2.419)	27.98 (9.56)
		7:1	0.06 (0.019)	0.19 (0.064)	0.76 (0.259)	2.01 (0.688)	5.11 (1.746)	19.46 (6.650)
		10:1	0.04 (0.015)	0.16 (0.054)	0.66 (0.225)	1.70 (0.581)	4.08 (1.394)	14.12 (4.825)
		12-16:1	0.08 (0.028)	0.18 (0.063)	0.63 (0.217)	1.50 (0.512)	3.49 (1.191)	13.10 (4.478)
		20-25:1	0.06 (0.021)	0.14 (0.048)	0.54 (0.183)	1.22 (0.416)	2.49 (0.849)	8.77 (2.998)
		28-40:1	0.05 (0.017)	0.13 (0.045)	0.50 (0.172)	1.11 (0.379)	2.12 (0.724)	7.03 (2.403)
Weight (m) With Bellows Coupling	kg (lbs)	1-stage	1.6 (3.5)	3.0 (6.5)	4.5 (10)	11 (24)	23 (50)	52 (115)
		2-stage	2.3 (5.0)	3.7 (8.0)	5.8 (12.8)	13 (28)	29 (63)	62 (137)
Weight (m) With Elastomer Coupling	kg (lbs)	1-stage	1.5 (3.2)	2.7 (5.9)	4.5 (10)	9.3 (21)	21 (46)	46 (102)
		2-stage	2.2 (4.8)	3.4 (7.4)	5.8 (12.9)	11 (25)	27 (59)	56 (124)
Noise Level (L_{pA})	dB(A)	1-stage	<60	<60	<63	<64	<65	<65
		2-stage	<60	<60	<61	<62	<63	<64
Efficiency at Load	1-stage: 98% 2-stage: 96%							
Service Life	>20,000 hours							
Lubrication	Lifetime lubrication with synthetic oil							
Protection Rating	IP64 (IP65/IP66 available on request)							
Operating Temperature Range	-25°C to +80°C (short term: 100°C)							

Sold & Serviced By:

1) Limited to 40 Nm(354 lb-in) for SPH-F and SPH-K. For higher torques, please contact GAM.

Toll Free Phone (877) SERV098
 Toll Free Fax (877) SERV099
www.electromate.com
sales@electromate.com

SPH-K

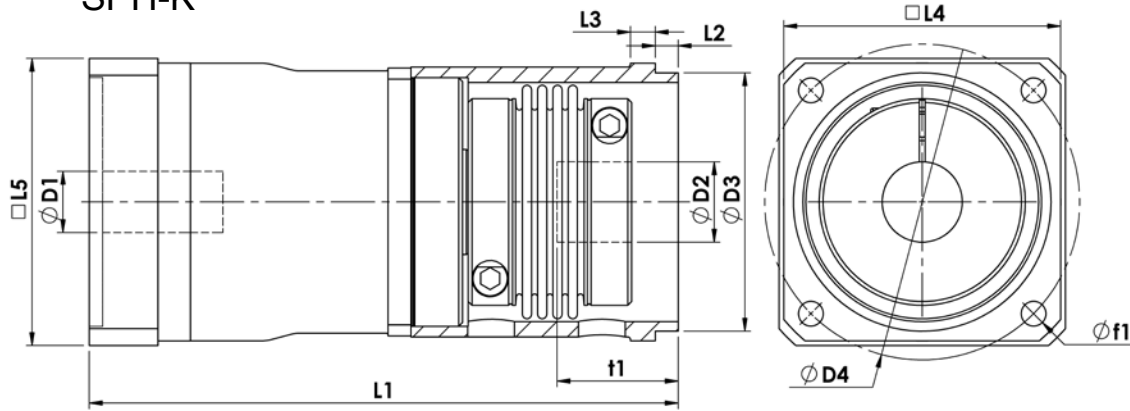

SPH-K		50		60		75		100		140		180	
		mm	(in)	mm	(in)	mm	(in)	mm	(in)	mm	(in)	mm	(in)
D1 _{max} Standard	Motor Shaft Diameter	11	(0.433)	14	(0.551)	19	(0.748)	24	(0.945)	32	(1.260)	38	(1.496)
D1 _{max} Available ¹		11	(0.433)	19	(0.748)	24	(0.945)	32	(1.260)	38	(1.496)	48	(1.890)
D1 _{max} 2-stage		11	(0.433)	14	(0.551)	19	(0.748)	24	(0.945)	32	(1.260)	38	(1.496)
D2 _{FB min}	Minimum Output Bore	10	(0.394)	12	(0.472)	22	(0.866)	22	(0.866)	42	(1.654)	50	(1.969)
D2 _{FE min}		12	(0.472)	18	(0.709)	22	(0.866)	35	(1.378)	38	(1.496)	48	(1.890)
D2 _{FB max}	Maximum Output Bore	20	(0.787)	28	(1.102)	38	(1.496)	50	(1.969)	64	(2.520)	90	(3.543)
D2 _{FE max}		19	(0.748)	26	(1.024)	33	(1.299)	42	(1.654)	56	(2.205)	70	(2.756)
D3 g6	Pilot Diameter	55	(2.165)	70	(2.756)	85	(3.346)	115	(4.528)	135	(5.315)	180	(7.087)
D4	Output Bolt Circle	70	(2.756)	85	(3.346)	105	(4.134)	140	(5.512)	165	(6.496)	215	(8.465)
f1	Mounting Holes	5.5	(0.217)	6.6	(0.260)	9	(0.354)	11	(0.433)	13	(0.512)	17	(0.669)
L1 ²	Overall Gearbox Length	155	(6.102)	189	(7.441)	214	(8.425)	262	(10.315)	308	(12.126)	386	(15.197)
L1 _{2-stage} ²		195	(7.677)	229	(9.016)	259	(10.197)	312	(12.283)	373	(14.685)	476	(18.740)
L2	Pilot Height	6	(0.236)	6	(0.236)	8	(0.315)	10	(0.394)	12	(0.472)	15	(0.591)
L3	Flange Thickness	6	(0.236)	7	(0.276)	9	(0.354)	11	(0.433)	13	(0.512)	15	(0.591)
L4	Output Square	60	(2.362)	70	(2.756)	95	(3.740)	120	(4.724)	145	(5.709)	190	(7.480)
L5 ²	Input Square	65	(2.559)	75	(2.953)	90	(3.543)	120	(4.724)	150	(5.906)	210	(8.268)
t1 _{FB min}	Minimum Shaft Engagement	24	(0.945)	27	(1.063)	39.5	(1.555)	44	(1.732)	49	(1.929)	65.5	(2.579)
t1 _{FE min}		21	(0.827)	29	(1.142)	38.5	(1.516)	45	(1.772)	49	(1.929)	70	(2.756)
t1 _{FB max}	Maximum Shaft Engagement	41	(1.614)	51	(2.008)	62	(2.441)	74	(2.913)	86	(3.386)	105	(4.134)
t1 _{FE max}		27.5	(1.083)	36.5	(1.437)	46	(1.811)	55	(2.165)	60	(2.362)	83	(3.268)

1) For larger motor shaft diameters, please contact GAM.

2) Depending on the motor, value can vary.

TYPE CODES FOR SPH-K SERIES

Example: SPH - KE - 060 - 005 G - [115 - 201] - S111

Gearbox Series

SPH Series

Gearbox Style

KB = Bellows coupling output
KE = Elastomer coupling output

Gearbox Size

050, 060, 075, 100, 140, 180

Ratio

3, 4, 5, 7, 10, 12, 15, 16, 20, 25, 28, 30,
35, 40, 50, 70, 100

Special Options

Assigned by GAM

Motor Mount Kit

Assigned by GAM

Options Available for This Product

G = Standard backlash and keyway
in output coupling

C = Reduced backlash and keyway
in output coupling

H = Standard backlash and no keyway
in output coupling

A = Reduced backlash and no keyway
in output coupling

Size	Tolerance (mm)	
	k6	g6
Over 6	+0.010	-0.005
Thru 10	+0.001	-0.014
Over 10	+0.012	-0.006
Thru 18	+0.001	-0.017
Over 18	+0.015	-0.007
Thru 30	+0.002	-0.020
Over 30	+0.018	-0.009
Thru 50	+0.002	-0.025
Over 50	+0.021	-0.010
Thru 80	+0.002	-0.029
Over 80	+0.025	-0.012
Thru 120	+0.003	-0.034
Over 120	+0.028	-0.014
Thru 180	+0.003	-0.037

Sold & Serviced By:

ELECTROMATE

Toll Free Phone (877) SERV098

Toll Free Fax (877) SERV099

www.electromate.com

sales@electromate.com



HIGHEST PERFORMANCE: SPH SERIES - SPH-F

SPH-F		50	60	75	100	140	180	
All Ratios Available		1 Stage: 3, 4, 5, 7, 10						
		2 Stage: 12, 15, 16, 20, 25, 28, 30, 35, 40, 50, 70, 100						
Nominal Output Torque (T_{2n})	Nm (lb-in)	3:1-5:1	20 (177)	60 ₁ (531)	100 (885)	250 (2213)	450 (3983)	900 (7966)
		7:1	18 (159)	40 (354)	80 (708)	180 (1593)	420 (3717)	800 (7081)
		10:1	15 (133)	30 (266)	65 (575)	110 (974)	240 (2124)	450 (3983)
		12:1-40:1	13 (115)	60 ₁ (531)	100 (885)	250 (2213)	450 (3983)	900 (7966)
		50:1	13 (115)	40 (354)	80 (708)	250 (2213)	450 (3983)	900 (7966)
		70:1	10 (89)	40 (354)	80 (708)	180 (1593)	420 (3717)	800 (7081)
100:1	7 (62)	30 (266)	65 (575)	110 (974)	240 (2124)	450 (3983)		
Max Acceleration Output Torque (T_{2B})	Nm (lb-in)	1.5 x Nominal (T_{2n})						
Emergency Output Torque (T_{2not})	Nm (lb-in)	3.5 x Nominal (T_{2n})						
Nominal Input Speed (n_{1n})	RPM	-	4500	4500	4500	4000	3800	2000
Max Input Speed (n_{1max})		-	6000					
Standard Output Backlash (j)	arcmin	1-stage	<4	<4	<4	<4	<4	<4
		2-stage	<6	<6	<6	<6	<6	<6
Reduced Output Backlash (j)	arcmin	1-stage	<3	<2	<2	<2	<2	<2
		2-stage	<5	<4	<4	<4	<4	<4
Torsional Stiffness (C_{t21}) With Bellows Coupling	Nm/arcmin (lb-in/arcmin)	1-stage	1.3 (11)	2.8 (25)	7.5 (66)	20 (175)	36 (317)	96 (851)
		2-stage	1.3 (11)	2.8 (25)	7.5 (66)	20 (175)	36 (317)	96 (851)
Torsional Stiffness (C_{t21}) With Elastomer Coupling	Nm/arcmin (lb-in/arcmin)	1-stage	0.3 (3)	0.5 (4)	1.0 (9)	3 (23)	5 (46)	11 (99)
		2-stage	0.3 (3)	0.5 (4)	1.0 (9)	3 (23)	5 (46)	11 (99)
Mass Moment of Inertia (J_1) With Bellows Coupling	kg-cm ² (lb-in ²)	3:1	0.18 (0.061)	0.62 (0.212)	1.65 (0.563)	6.89 (2.354)	18.90 (6.458)	89.86 (30.71)
		4:1	0.11 (0.037)	0.40 (0.138)	1.17 (0.399)	4.53 (1.546)	11.83 (4.041)	54.40 (18.59)
		5:1	0.08 (0.027)	0.29 (0.100)	0.93 (0.318)	3.24 (1.107)	8.36 (2.857)	35.82 (12.240)
		7:1	0.06 (0.020)	0.21 (0.071)	0.75 (0.257)	2.34 (0.800)	5.76 (1.969)	23.46 (8.017)
		10:1	0.04 (0.015)	0.17 (0.057)	0.66 (0.224)	1.86 (0.636)	4.40 (1.504)	16.08 (5.495)
		12-16:1	0.08 (0.028)	0.19 (0.064)	0.63 (0.217)	1.56 (0.534)	3.61 (1.234)	13.87 (4.739)
		20-25:1	0.06 (0.021)	0.14 (0.049)	0.54 (0.183)	1.24 (0.424)	2.54 (0.867)	9.09 (3.105)
		28-40:1	0.05 (0.017)	0.13 (0.045)	0.50 (0.172)	1.12 (0.383)	2.14 (0.733)	7.19 (2.458)
Mass Moment of Inertia (J_1) With Elastomer Coupling	kg-cm ² (lb-in ²)	3:1	0.16 (0.056)	0.52 (0.178)	1.68 (0.575)	5.11 (1.747)	15.34 (5.243)	68.08 (23.26)
		4:1	0.10 (0.034)	0.35 (0.118)	1.19 (0.406)	3.53 (1.205)	9.83 (3.357)	42.15 (14.403)
		5:1	0.07 (0.025)	0.26 (0.087)	0.94 (0.322)	2.60 (0.888)	7.08 (2.419)	27.98 (9.56)
		7:1	0.06 (0.019)	0.19 (0.064)	0.76 (0.259)	2.01 (0.688)	5.11 (1.746)	19.46 (6.650)
		10:1	0.04 (0.015)	0.16 (0.054)	0.66 (0.225)	1.70 (0.581)	4.08 (1.394)	14.12 (4.83)
		12-16:1	0.08 (0.028)	0.18 (0.063)	0.63 (0.217)	1.50 (0.512)	3.49 (1.191)	13.10 (4.478)
		20-25:1	0.06 (0.021)	0.14 (0.048)	0.54 (0.183)	1.22 (0.416)	2.49 (0.849)	8.77 (3.00)
		28-40:1	0.05 (0.017)	0.13 (0.045)	0.50 (0.172)	1.11 (0.379)	2.12 (0.724)	7.03 (2.403)
Weight (m) With Bellows Coupling	kg (lbs)	1-stage	1.3 (2.9)	2.7 (6.0)	4.1 (9)	9.7 (21)	21 (46)	47 (103)
		2-stage	2.0 (4.5)	3.4 (7.5)	5.4 (11.9)	12 (25)	27 (59)	57 (125)
Weight (m) With Elastomer Coupling	kg (lbs)	1-stage	1.2 (2.7)	2.4 (5.3)	4.1 (9)	8.2 (18)	19 (42)	41 (89)
		2-stage	1.9 (4.2)	3.1 (6.9)	5.4 (11.9)	10 (22)	25 (55)	51 (111)
Noise Level (L_{pA})	dB(A)	1-stage	<60	<60	<63	<64	<65	<65
		2-stage	<60	<60	<61	<62	<63	<64
Efficiency at Load	1-stage: 98% 2-stage: 96%							
Service Life	>20,000 hours							
Lubrication	Lifetime lubrication with synthetic oil							
Protection Rating	IP64 (IP65/IP66 available on request)							
Operating Temperature Range	-25°C to +80°C (short term: 100°C)							

Sold & Serviced By:

1) Limited to 40 Nm(354 lb-in) for SPH-F and SPH-K. For higher torques, please contact GAM.

Toll Free Phone (877) SERV098
 Toll Free Fax (877) SERV099
www.electromate.com
sales@electromate.com

SPH-F

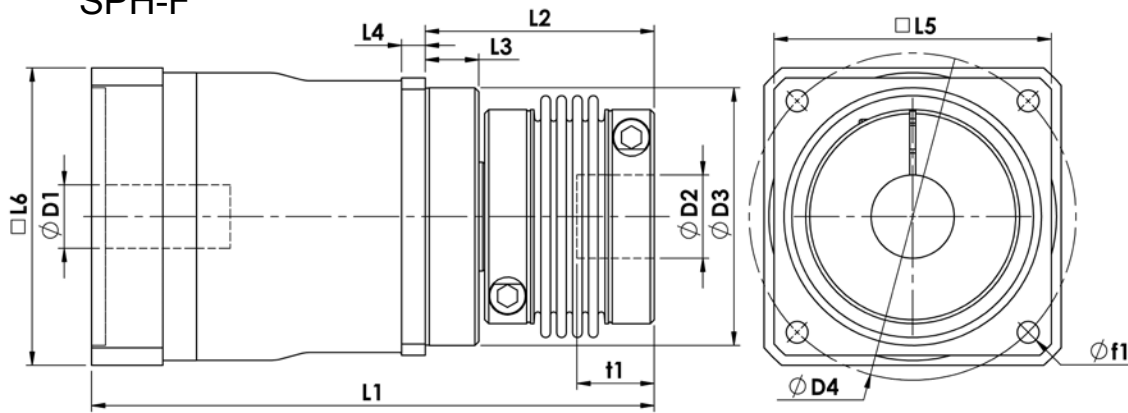

SPH-F		50		60		75		100		140		180	
		mm	(in)	mm	(in)	mm	(in)	mm	(in)	mm	(in)	mm	(in)
D1 _{max} Standard	Motor Shaft Diameter	11	(0.433)	14	(0.551)	19	(0.748)	24	(0.945)	32	(1.260)	38	(1.496)
D1 _{max} Available ¹		11	(0.433)	19	(0.748)	24	(0.945)	32	(1.260)	38	(1.496)	48	(1.890)
D1 _{max} 2-stage		11	(0.433)	14	(0.551)	19	(0.748)	24	(0.945)	32	(1.260)	38	(1.496)
D2 _{FB min}	Minimum Output Bore	10	(0.394)	12	(0.472)	22	(0.866)	22	(0.866)	42	(1.654)	50	(1.969)
D2 _{FE min}		12	(0.472)	18	(0.709)	22	(0.866)	35	(1.378)	38	(1.496)	48	(1.890)
D2 _{FB max}	Maximum Output Bore	20	(0.787)	28	(1.102)	38	(1.496)	50	(1.969)	64	(2.520)	90	(3.543)
D2 _{FE max}		19	(0.748)	26	(1.024)	33	(1.299)	42	(1.654)	56	(2.205)	70	(2.756)
D3 g6	Pilot Diameter	45	(1.772)	60	(2.362)	70	(2.756)	90	(3.543)	130	(5.118)	160	(6.299)
D4	Output Bolt Circle	63	(2.480)	68	(2.677)	85	(3.346)	120	(4.724)	165	(6.496)	215	(8.465)
f1	Mounting Holes	5.5	(0.217)	6	(0.236)	6.6	(0.260)	9	(0.354)	11	(0.433)	13	(0.512)
L1FB ²	Overall Gearbox Length	144	(5.669)	177	(6.969)	197	(7.756)	244	(9.606)	283	(11.142)	356	(14.016)
L1FE ²		151	(5.945)	180	(7.087)	202	(7.953)	248	(9.764)	292	(11.496)	354	(13.937)
L1FB _{2-stage} ²		184	(7.244)	217	(8.543)	242	(9.528)	294	(11.575)	348	(13.701)	446	(17.559)
L1FE _{2-stage} ²		191	(7.520)	220	(8.661)	247	(9.724)	298	(11.732)	357	(14.055)	444	(17.480)
L2FB	Coupling Length	57	(2.244)	75	(2.953)	88	(3.465)	112	(4.409)	115	(4.528)	138	(5.433)
L2FE		64	(2.520)	78	(3.071)	93	(3.661)	116	(4.567)	124	(4.882)	136	(5.354)
L3	Pilot Height	12	(0.472)	18	(0.709)	18	(0.709)	28	(1.102)	27	(1.063)	27	(1.063)
L4	Flange Thickness	6	(0.236)	6	(0.236)	7	(0.276)	10	(0.394)	12	(0.472)	18	(0.709)
L5	Output Square	55	(2.165)	61	(2.402)	75	(2.953)	100	(3.937)	140	(5.512)	180	(7.087)
L6 ²	Input Square	65	(2.559)	75	(2.953)	90	(3.543)	120	(4.724)	150	(5.906)	210	(8.268)
t1 _{FB min}	Minimum Shaft Engagement	13	(0.512)	16	(0.630)	22	(0.866)	26	(1.024)	24	(0.945)	35.5	(1.398)
t1 _{FE min}		17	(0.669)	20	(0.787)	26.5	(1.043)	31	(1.220)	33	(1.299)	38	(1.496)
t1 _{FB max}	Maximum Shaft Engagement	30	(1.181)	39	(1.535)	45	(1.772)	56	(2.205)	61	(2.402)	75.5	(2.972)
t1 _{FE max}		23.5	(0.925)	27.5	(1.083)	34.5	(1.358)	41	(1.614)	44	(1.732)	51	(2.008)

1) For larger motor shaft diameters, please contact GAM.

2) Depending on the motor, value can vary.

TYPE CODES FOR SPH-F SERIES

Example: SPH - FE - 060 - 005 G - [115 - 201] - S111

Gearbox Series
SPH Series

Gearbox Style
FB = Bellows coupling output
FE = Elastomer coupling output

Gearbox Size
050, 060, 075, 100, 140, 180

Ratio
3, 4, 5, 7, 10, 12, 15, 16, 20, 25, 28, 30,
35, 40, 50, 70, 100

Special Options
Assigned by GAM

Motor Mount Kit
Assigned by GAM

Options Available for This Product
G = Standard backlash and keyway in output coupling
C = Reduced backlash and keyway in output coupling
H = Standard backlash and no keyway in output coupling
A = Reduced backlash and no keyway in output coupling

Size	Tolerance (mm)	
	k6	g6
Over 6	+0.010	-0.005
Thru 10	+0.001	-0.014
Over 10	+0.012	-0.006
Thru 18	+0.001	-0.017
Over 18	+0.015	-0.007
Thru 30	+0.002	-0.020
Over 30	+0.018	-0.009
Thru 50	+0.002	-0.025
Over 50	+0.021	-0.010
Thru 80	+0.002	-0.029
Over 80	+0.025	-0.012
Thru 120	+0.003	-0.034
Over 120	+0.028	-0.014
Thru 180	+0.003	-0.037

Sold & Serviced By:



Toll Free Phone (877) SERV098
Toll Free Fax (877) SERV099
www.electromate.com
sales@electromate.com



▶ HIGHEST PERFORMANCE: SPL SERIES

GAM can.

If you don't see exactly what you need, let us know. We can modify the SPL Series gearboxes to meet your needs. Page 4 provides a list of commonly requested modifications to give you a feel for our capabilities.

The SPL is the next generation of our I.M.P.A.C.T.[®] series. It has been designed with the latest servo motors and your most demanding motion control applications in mind. The SPL can handle oversized motor shafts, higher input speeds, and high torques. Now the SPL has been expanded to incorporate our unique Integrated Modular Planetary and Coupling Technology (I.M.P.A.C.T.[®]). Our planetary and coupling package increases system stiffness and reduces the overall costs of conventional packages.

The SPL gearbox performance and quality, along with GAM's manufacturing flexibility and overall service, will provide you with the best solution on the market!

Benefits of the SPL Series include:

- Precision gears equal low backlash with quiet operation
- Long wear life: 30,000 hours
- Lubricated for life
- Ready for motor mounting
- Output dimensions match those of many conventional planetary gearboxes on the market
- Ratios from 3:1 to 100:1
- Frame sizes from 60 mm to 180 mm

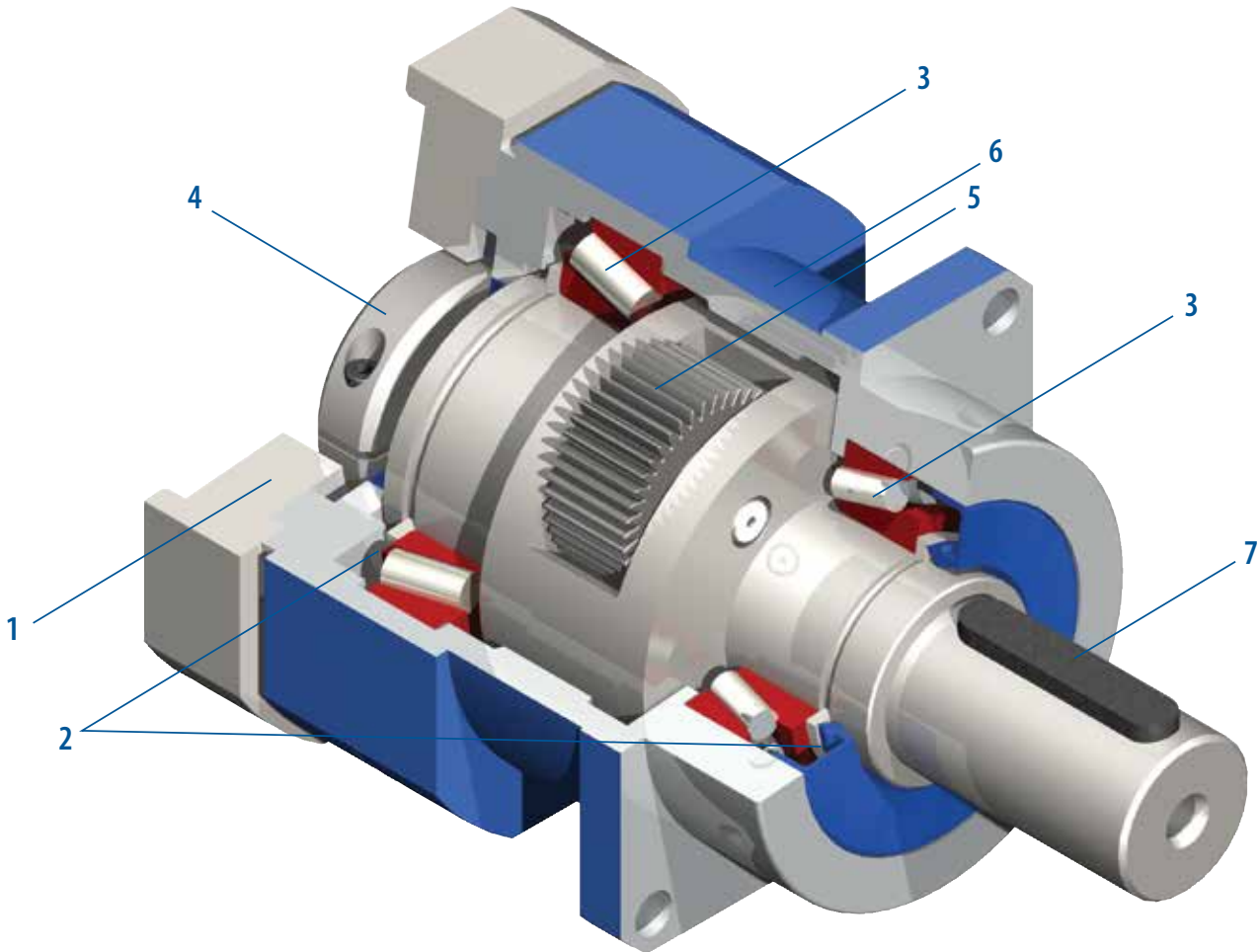

1. Adapter Flange
(Customized adapter flanges for quick and easy motor mounting)
2. Viton[®] Seals
(Protective seals to isolate the gearbox)
3. Bearings
(Tapered roller bearings accommodate high overhung loads)

4. Input Clamping Element
5. Planet Gears
(Extra large face width gears pack a high level of torque in a small gearbox frame)
6. Gear Housing
(Ring gear incorporated into housing)
7. Keyway
(Available with keyway on output shaft)

Sold & Serviced By:



Toll Free Phone (877) SERV098
Toll Free Fax (877) SERV099
www.electromate.com
sales@electromate.com

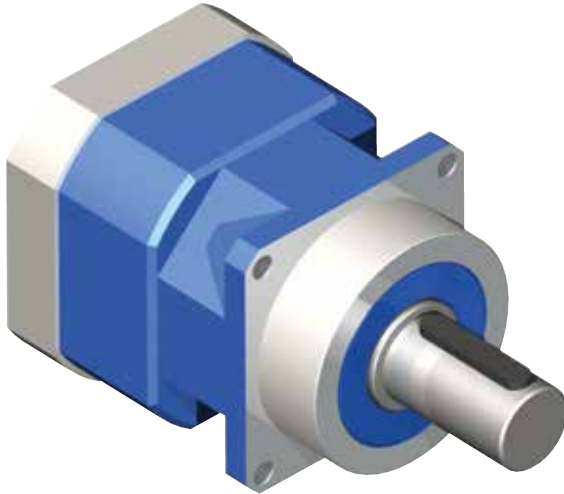

SPL-W

- Shaft output design for mounting to pulleys and rack and pinion systems
- Ratios from 3:1 to 100:1
- Frame sizes from 60 mm to 180 mm (larger sizes available by request)

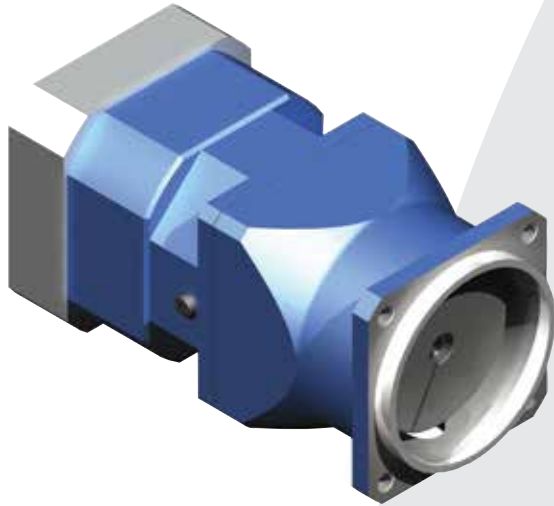

SPL-K

- SPL-KB features a bellows coupling on the output
- Innovative bellow coupling on the output provides for maximum stiffness and best results in high dynamic applications
- Also available with a zero backlash elastomer-spider style coupling (SPL-KE) on the output
- Ratios from 3:1 to 100:1
- Frame sizes from 60 mm to 180 mm
- Output lantern comes standard with the SPL-K
- Custom lanterns available

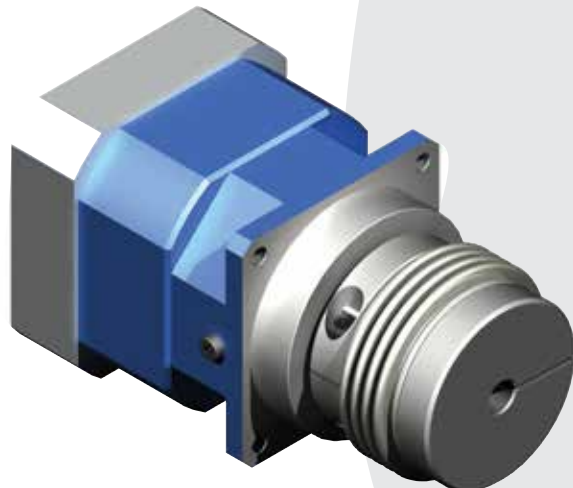

SPL-F

- Same benefits as the SPL-K models without the bell housing on the output. Plug the gearbox into your machine and achieve a more compact design
- Ratios from 3:1 to 100:1
- Frame sizes from 60 mm to 180 mm

Sold & Serviced By:

 **ELECTROMATE**

Toll Free Phone (877) SERV098

Toll Free Fax (877) SERV099

www.electromate.com

sales@electromate.com



SPL SERIES - SPL-W

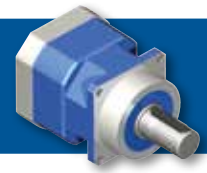

SPL - W			60	75	100	140	180	
Stock Ratios			5,10					
All Ratios Available			1 Stage: 3, 4, 5, 7, 10 2 Stage: 12, 16, 20, 25, 35, 40, 50, 70, 100					
Nominal Output Torque (T_{2n})	Nm (lb-in)	3:1	26 (230)	39 (345)	110 (974)	210 (1859)	600 (5310)	
		4, 5, 7:1	32 (283)	65 (575)	150 (1328)	340 (3009)	600 (5310)	
		10:1	24 (212)	40 (354)	115 (1018)	210 (1859)	600 (5310)	
		2-Stage (except 100:1)	38 (336)	85 (752)	180 (1593)	400 (3540)	600 (5310)	
		100:1	28 (248)	48 (425)	130 (1151)	250 (2213)	600 (5310)	
Max Acceleration Output Torque (T_{2B})	Nm (lb-in)	3:1	36 (319)	80 (708)	180 (1593)	380 (3363)	1200 (10620)	
		4, 5, 7:1	50 (443)	120 (1062)	250 (2213)	540 (4779)	1300 (11505)	
		10:1	36 (319)	94 (832)	200 (1770)	440 (3894)	1200 (10620)	
		2-Stage (except 100:1)	54 (478)	125 (1106)	260 (2301)	550 (4868)	1300 (11505)	
		100:1	38 (336)	94 (832)	200 (1770)	440 (3894)	1200 (10620)	
Emergency Output Torque (T_{2not})	Nm (lb-in)	3:1	100 (885)	200 (1770)	500 (4425)	1000 (8850)	1850 (16373)	
		4, 5, 7:1	120 (1062)	240 (2124)	600 (5310)	1260 (11151)	2450 (21683)	
		10:1	90 (797)	200 (1770)	500 (4425)	1000 (8850)	2800 (24780)	
		2-Stage (except 100:1)	120 (1062)	240 (2124)	600 (5310)	1260 (11151)	2450 (21683)	
		100:1	90 (797)	200 (1770)	500 (4425)	1000 (8850)	2800 (24780)	
Nominal Speed (n_{1n})	RPM	-	4500	4500	4000	3800	2000	
Max Speed (n_{1max})		-	6500	6000	6000	5500	3500	
Standard Output Backlash (j)	arcmin	1-stage	< 6	< 5	< 5	< 5	< 4	
		2-stage	< 7	< 6	< 6	< 6	< 6	
Reduced Output Backlash (j)	arcmin	1-stage	< 4	< 3	< 3	< 3	< 2	
		2-stage	< 5	< 4	< 4	< 4	< 4	
Allowable Radial Load (F_{rad}) ⁽¹⁾	N (lbs)	-	3000 (675)	4200 (945)	6300 (1418)	11000 (2475)	13000 (2925)	
Allowable Axial Load (F_{axial})	N (lbs)	-	2400 (540)	3800 (855)	5600 (1260)	10600 (2385)	13500 (3038)	
Torsional Stiffness (C_{221})	Nm/arcmin (lb-in/arcmin)	1-stage	5 (44)	13 (115)	40 (354)	56 (496)	130 (1151)	
		2-stage	5 (44)	13 (115)	40 (354)	56 (496)	130 (1151)	
Weight (m)	kg (lbs)	1-stage	2.6 (5.7)	3.7 (8.2)	7.2 (15.9)	19.3 (42.6)	32 (71)	
		2-stage	3.3 (7.3)	4.2 (9.3)	9.5 (20.9)	23.3 (51.4)	36.6 (81)	
Noise Level (L_{PA})	dB(A)		< 64	< 65	< 67	< 67	< 70	
Mass Moment of Inertia (J_1)	kg cm ² (lb-in ²)	3:1	0.43 (0.168)	1.15 (0.450)	6.05 (2.368)	14.25 (5.578)	53 (20.75)	
		4:1	0.33 (0.129)	0.92 (0.360)	4.05 (1.585)	9.31 (3.644)	39 (15.27)	
		5:1	0.27 (0.106)	0.81 (0.317)	3.17 (1.241)	6.91 (2.705)	34 (13.31)	
		7:1	0.23 (0.090)	0.72 (0.282)	2.44 (0.955)	4.91 (1.922)	31 (12.14)	
		10:1	0.2 (0.078)	0.67 (0.262)	2.08 (0.814)	3.89 (1.523)	29 (11.35)	
Efficiency at Load			1-stage: 96% 2-stage: 94%					
Service Life			> 30,000 hours					
Lubrication			Lifetime lubrication with synthetic oil					
Protection Rating			IP65					
Operating Temperature Range			-20°C to 90°C					

Sold & Serviced By:
ELECTROMATE
 Toll Free Phone (877) SERV098
 Toll Free Fax (877) SERV099
www.electromate.com
sales@electromate.com

SPL-W

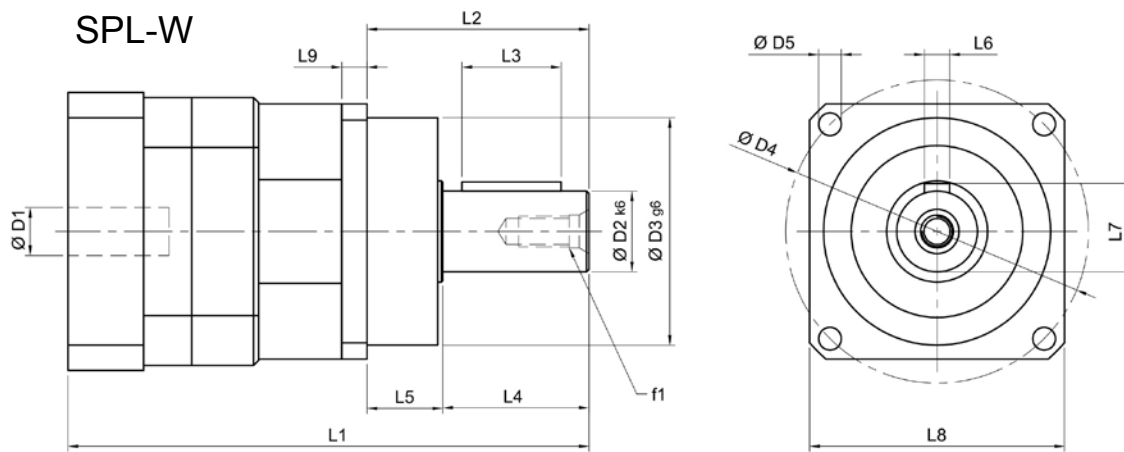

SPL-W		60		75		100		140		180	
		mm	(in)	mm	(in)	mm	(in)	mm	(in)	mm	(in)
D1 max standard	motor shaft diameter	14	(0.551)	19	(0.748)	24	(0.945)	32	(1.260)	54	(2.126)
D1 max available*	motor shaft diameter	19	(0.748)	24	(0.945)	32	(1.26)	38	(1.496)	54	(2.126)
D1 max 2-stage	motor shaft diameter	14	(0.551)	19	(0.748)	24	(0.945)	34	(1.339)	38	(1.496)
D2 k6	output shaft diameter	16	(0.63)	22	(0.866)	32	(1.26)	40	(1.575)	55	(2.165)
D3 g6	pilot diameter	60	(2.362)	70	(2.756)	90	(3.543)	130	(5.118)	160	(6.299)
D4	bolt circle	68	(2.677)	85	(3.346)	120	(4.724)	165	(6.496)	215	(8.465)
f1	shaft thread	M5 x 12		M8 x 19		M12 x 26		M16 x 36		M20 x 42	
D5	mounting holes ø	ø5.5		ø6.6		ø9		ø11		ø13	
L1 1-STAGE**	gearbox total length	151 (5.945)		174.5 (6.87)		226.5 (8.917)		292 (11.496)		312 (12.283)	
L1 2-STAGE**		178 (7.008)		201 (7.913)		251 (9.882)		342 (13.465)		334 (13.15)	
L2	shaft length	48 (1.89)		56 (2.205)		88 (3.465)		112 (4.409)		100 (3.937)	
L3	key length	25 (0.984)		32 (1.26)		50 (1.969)		70 (2.756)		63 (2.756)	
L4	usable shaft length	28 (1.102)		36 (1.417)		58 (2.283)		82 (3.228)		82 (3.228)	
L5	pilot height	20 (0.787)		20 (0.787)		30 (1.181)		30 (1.181)		14 (0.551)	
L6	key width	5 (0.197)		6 (0.236)		10 (0.394)		12 (0.472)		16 (0.630)	
L7	key height	18 (0.709)		24.5 (0.965)		35 (1.378)		43 (1.693)		60 (2.362)	
L8	output square	65 (2.559)		76 (2.992)		101 (3.976)		141 (5.551)		180 (7.087)	
L9	flange thickness	6 (0.236)		7 (0.276)		10 (0.394)		12 (0.472)		14 (0.551)	

* for larger motor shaft diameters, please contact GAM ** depending on the motor, value can vary

TYPE CODES FOR SPL SERIES (SPL-W)

Example: SPL - W - 075 - 005 G - [115 - A01] - S111

Gearbox Series

SPL Series

Gearbox Style

W = Output Shaft

Gearbox Size

060, 075, 100, 140, 180

Ratio

3, 4, 5, 7, 10, 12, 16, 20, 25, 35, 40, 50, 70, 100

Special Options

Assigned by GAM

Motor Mount Kit

Assigned by GAM

Options Available for This Product

G = Key on output shaft per DIN6885

C = Reduced backlash and key on output shaft

H = Smooth output shaft

A = Reduced backlash and smooth shaft

Tolerances (mm)

Size	k6	g6
Over 6	+0.010	-0.005
Thru 10	+0.001	-0.014
Over 10	+0.012	-0.006
Thru 18	+0.001	-0.017
Over 18	+0.015	-0.007
Thru 30	+0.002	-0.020
Over 30	+0.018	-0.009
Thru 50	+0.002	-0.025
Over 50	+0.021	-0.010
Thru 80	+0.002	-0.029
Over 80	+0.025	-0.012
Thru 120	+0.003	-0.034
Over 120	+0.028	-0.014
Thru 180	+0.003	-0.037

Sold & Serviced By:

ELECTROMATE

Toll Free Phone (877) SERV098

Toll Free Fax (877) SERV099

www.electromate.com

sales@electromate.com



SPL SERIES - SPL-K

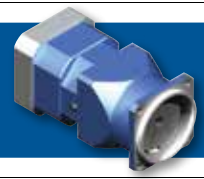

SPL-K		60	75	100	140	180	
Stock Ratios		5,10					
All Ratios Available		1 Stage: 3, 4, 5, 7, 10 2 Stage: 12, 16, 20, 25, 35, 40, 50, 70, 100					
Nominal Output Torque (T_{2n})	Nm (lb-in)	3:1	26 (230)	39 (345)	110 (974)	210 (1859)	600 (5310)
		4, 5, 7:1	32 (283)	65 (575)	150 (1328)	340 (3009)	600 (5310)
		10:1	24 (212)	40 (354)	115 (1018)	210 (1859)	600 (5310)
		2-Stage (except 100:1)	38 (336)	85 (752)	180 (1593)	400 (3540)	600 (5310)
		100:1	28 (248)	48 (425)	130 (1151)	250 (2213)	600 (5310)
Max Acceleration Output Torque (T_{2B})	Nm (lb-in)	3:1	36 (319)	80 (708)	180 (1593)	380 (3363)	1200 (10620)
		4, 5, 7:1	50 (443)	120 (1062)	250 (2213)	540 (4779)	1300 (11505)
		10:1	36 (319)	94 (832)	200 (1770)	440 (3894)	1200 (10620)
		2-Stage (except 100:1)	54 (478)	125 (1106)	260 (2301)	550 (4868)	1300 (11505)
		100:1	38 (336)	94 (832)	200 (1770)	440 (3894)	1200 (10620)
Emergency Output Torque (T_{2not})	Nm (lb-in)	3:1	100 (885)	200 (1770)	500 (4425)	1000 (8850)	1850 (16373)
		4, 5, 7:1	120 (1062)	240 (2124)	600 (5310)	1260 (11151)	2450 (21683)
		10:1	90 (797)	200 (1770)	500 (4425)	1000 (8850)	2800 (24780)
		2-Stage (except 100:1)	120 (1062)	240 (2124)	600 (5310)	1260 (11151)	2450 (21683)
		100:1	90 (797)	200 (1770)	500 (4425)	1000 (8850)	2800 (24780)
Nominal Speed (n_{1n})	RPM	-	4500	4500	4000	3800	2000
Max Speed (n_{1max})		-	6500	6000	6000	5500	3500
Standard Output Backlash (j)	arcmin	1-stage	< 6	< 5	< 5	< 5	< 4
		2-stage	< 7	< 6	< 6	< 6	< 6
Reduced Output Backlash (j)	arcmin	1-stage	< 4	< 3	< 3	< 3	< 2
		2-stage	< 5	< 4	< 4	< 4	< 4
Torsional Stiffness (C_{21})	Nm/arcmin (lb-in/arcmin)	1-stage	3.21 (28.4)	7.88 (69.7)	22.61 (200.1)	36.64 (324.3)	36.6 (324.3)
		2-stage	3.21 (28.4)	7.88 (69.7)	22.61 (200.1)	36.64 (324.3)	36.6 (324.3)
Weight (m)	kg (lbs)	1-stage	3.35 (7.39)	4.61 (10.16)	9.82 (21.65)	24.55 (54.12)	38.4 (84.7)
		2-stage	4.05 (8.93)	5.11 (11.27)	12.12 (26.72)	28.55 (62.94)	43 (94.8)
Noise Level (L_{pA})	dB(A)		< 64	< 65	< 67	< 67	< 70
Mass Moment of Inertia (J_1)	kg cm ² (lb-in ²)	3:1	0.65 (0.223)	2.82 (0.962)	10.11 (3.454)	21.31 (7.283)	53 (18.090)
		4:1	0.54 (0.185)	2.41 (0.822)	6.87 (2.346)	13.79 (4.711)	39 (13.310)
		5:1	0.49 (0.168)	2.23 (0.762)	5.41 (1.848)	10.2 (3.486)	39 (13.310)
		7:1	0.44 (0.150)	2.06 (0.704)	4.18 (1.428)	7.15 (2.444)	31 (10.580)
		10:1	0.42 (0.143)	1.98 (0.678)	3.55 (1.213)	5.59 (1.910)	31 (10.580)
Efficiency at Load		1-stage: 96% 2-stage: 94%					
Service Life		> 30,000 hours					
Lubrication		Lifetime lubrication with synthetic oil					
Protection Rating		IP65					
Operating Temperature Range		-20°C to 90°C					

Sold & Serviced By: **ELECTROMATE**

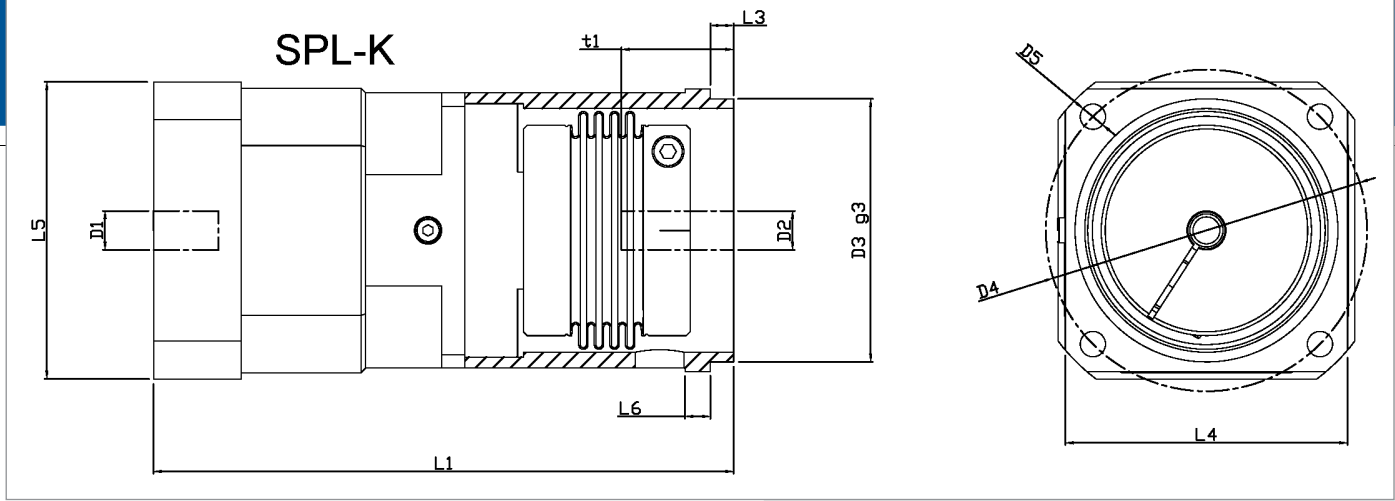

SPL-K		60		75		100		140		180	
		mm	(in)	mm	(in)	mm	(in)	mm	(in)	mm	(in)
D1 max standard	motor shaft diameter	14	(0.551)	19	(0.748)	24	(0.945)	32	(1.260)	54	(2.126)
D1 max available*	motor shaft diameter	19	(0.748)	24	(0.945)	32	(1.26)	38	(1.496)	54	(2.126)
D1 max 2-stage	motor shaft diameter	14	(0.551)	19	(0.748)	24	(0.945)	34	(1.339)	38	(1.496)
D2 _{max} - KB	max output bore	28	(1.102)	38	(1.496)	50	(1.969)	64	(2.520)	85	(3.346)
D2 _{max} - KE	max output bore	26	(1.024)	38	(1.496)	46	(1.811)	56	(2.205)	-	-
D3 _{g6} - KB/E	pilot diameter	70	(2.756)	85	(3.346)	115	(4.528)	135	(5.315)	180	(7.087)
D4 _{KB/E}	bolt circle	85	(3.346)	105	(4.134)	140	(5.512)	165	(6.496)	215	(8.465)
D5 _{KB/E}	bolt hole	6.6	(0.26)	9	(0.354)	11	(0.433)	13	(0.512)	17	(0.669)
L1 _{1-stage} KB/E**	gearbox total length	180	(7.087)	207	(8.150)	241.5	(9.508)	300	(11.811)	326	(12.835)
L1 _{2-stage} KB/E**	gearbox total length	207	(8.150)	233.5	(9.193)	266	(10.472)	350	(13.780)	340	(13.386)
L3 _{KB/E}	pilot height	6	(0.236)	8	(0.315)	10	(0.394)	12	(0.472)	15	(0.591)
L4 _{KB/E}	output flange size	70	(2.756)	95	(3.74)	120	(4.724)	145	(5.709)	190	(7.48)
L5**	gearbox thickness	70	(2.756)	81	(3.189)	106	(4.173)	146	(5.748)	200	(7.874)
L6 _{KB/E}	flange thickness	7	(0.276)	9	(0.354)	11	(0.433)	13	(0.512)	15	(0.591)
t1 _{min} - KB	min shaft engagement	21	(0.827)	26	(1.024)	32	(1.260)	33	(1.300)	59	(2.323)
t1 _{max} - KB	max shaft engagement	43	(1.693)	58.5	(2.3031)	60	(2.362)	68	(2.677)	88	(3.465)
t1 _{min} - KE	min shaft engagement	22	(0.866)	28	(1.102)	34	(1.339)	36	(1.417)	-	-
t1 _{max} - KE	max shaft engagement	31.5	(1.240)	38.5	(1.516)	45	(1.772)	48.5	(1.909)	-	-

* for larger motor shaft diameters, please contact GAM ** depending on the motor, value can vary

TYPE CODES FOR SPL-K SERIES

Example: SPL - KE - 060 - 005 G - [115-201] - S111

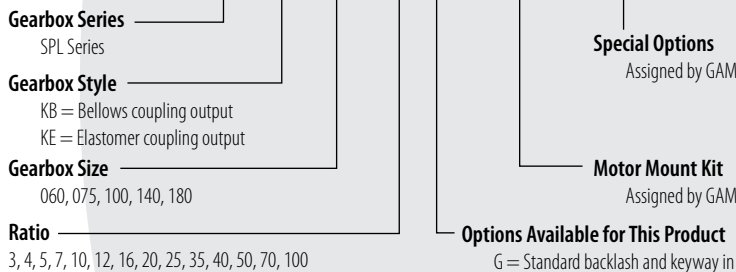

Tolerances (mm)		
Size	k6	g6
Over 6	+0.010	-0.005
Thru 10	+0.001	-0.014
Over 10	+0.012	-0.006
Thru 18	+0.001	-0.017
Over 18	+0.015	-0.007
Thru 30	+0.002	-0.020
Over 30	+0.018	-0.009
Thru 50	+0.002	-0.025
Over 50	+0.021	-0.010
Thru 80	+0.002	-0.029
Over 80	+0.025	-0.012
Thru 120	+0.003	-0.034
Over 120	+0.028	-0.014
Thru 180	+0.003	-0.037

Options Available for This Product
 G = Standard backlash and keyway in output coupling
 C = Reduced backlash and keyway in output coupling
 H = Standard backlash and no keyway in output coupling
 A = Reduced backlash and no keyway in output coupling



SPL SERIES - SPL-F



SPL-F			60	75	100	140	180	
Stock Ratios			5,10					
All Ratios Available			1 Stage: 3, 4, 5, 7, 10 2 Stage: 12, 16, 20, 25, 35, 40, 50, 70, 100					
Nominal Output Torque (T_{2n})	Nm (lb-in)	3:1	26 (230)	39 (345)	110 (974)	210 (1859)	600 (5310)	
		4, 5, 7:1	32 (283)	65 (575)	150 (1328)	340 (3009)	600 (5310)	
		10:1	24 (212)	40 (354)	115 (1018)	210 (1859)	600 (5310)	
		2-Stage (except 100:1)	38 (336)	85 (752)	180 (1593)	400 (3540)	600 (5310)	
		100:1	28 (248)	48 (425)	130 (1151)	250 (2213)	600 (5310)	
Max Acceleration Output Torque (T_{2a})	Nm (lb-in)	3:1	36 (319)	80 (708)	180 (1593)	380 (3363)	1200 (10620)	
		4, 5, 7:1	50 (443)	120 (1062)	250 (2213)	540 (4779)	1300 (11505)	
		10:1	36 (319)	94 (832)	200 (1770)	440 (3894)	1200 (10620)	
		2-Stage (except 100:1)	54 (478)	125 (1106)	260 (2301)	550 (4868)	1300 (11505)	
		100:1	38 (336)	94 (832)	200 (1770)	440 (3894)	1200 (10620)	
Emergency Output Torque (T_{2em})	Nm (lb-in)	3:1	100 (885)	200 (1770)	500 (4425)	1000 (8850)	1850 (16373)	
		4, 5, 7:1	120 (1062)	240 (2124)	600 (5310)	1260 (11151)	2450 (21683)	
		10:1	90 (797)	200 (1770)	500 (4425)	1000 (8850)	2800 (24780)	
		2-Stage (except 100:1)	120 (1062)	240 (2124)	600 (5310)	1260 (11151)	2450 (21683)	
		100:1	90 (797)	200 (1770)	500 (4425)	1000 (8850)	2800 (24780)	
Nominal Speed (n_{1n})	RPM	-	4500	4500	4000	3800	2000	
Max Speed (n_{1max})		-	6500	6000	6000	5500	3500	
Standard Output Backlash (j)	arcmin	1-stage	< 6	< 5	< 5	< 5	< 4	
		2-stage	< 7	< 6	< 6	< 6	< 6	
Reduced Output Backlash (j)	arcmin	1-stage	< 4	< 3	< 3	< 3	< 2	
		2-stage	< 5	< 4	< 4	< 4	< 4	
Torsional Stiffness (C_{21})	Nm/arcmin (lb-in/arcmin)	1-stage	3.21 (28.4)	7.88 (69.7)	22.61 (200.1)	36.64 (324.3)	36.6 (324.3)	
		2-stage	3.21 (28.4)	7.88 (69.7)	22.61 (200.1)	36.64 (324.3)	36.6 (324.3)	
Weight (m)	kg (lbs)	1-stage	3.1 (6.8)	4.2 (9.3)	8.7 (19.2)	22.7 (50.1)	32.8 (72.3)	
		2-stage	3.8 (8.4)	4.7 (10.4)	11 (24.2)	26.7 (58.9)	37.4 (82.5)	
Noise Level (L_{pa})	dB(A)		< 64	< 65	< 67	< 67	< 70	
Mass Moment of Inertia (J_1)	kg cm ² (lb-in ²)	3:1	0.65 (0.223)	2.82 (0.962)	10.11 (3.454)	21.31 (7.283)	53 (18.090)	
		4:1	0.54 (0.185)	2.41 (0.822)	6.87 (2.346)	13.79 (4.711)	39 (13.310)	
		5:1	0.49 (0.168)	2.23 (0.762)	5.41 (1.848)	10.2 (3.486)	39 (13.310)	
		7:1	0.44 (0.150)	2.06 (0.704)	4.18 (1.428)	7.15 (2.444)	31 (10.580)	
		10:1	0.42 (0.143)	1.98 (0.678)	3.55 (1.213)	5.59 (1.910)	31 (10.580)	
Efficiency at Load		1-stage: 96% 2-stage: 94%						
Service Life		> 30,000 hours						
Lubrication		Lifetime lubrication with synthetic oil						
Protection Rating		IP65						
Operating Temperature Range		-20°C to 90°C						

Sold & Serviced By: **ELECTROMATE**

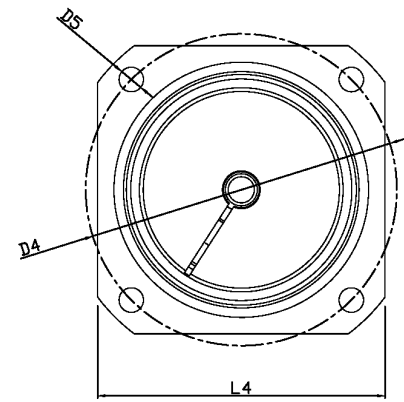
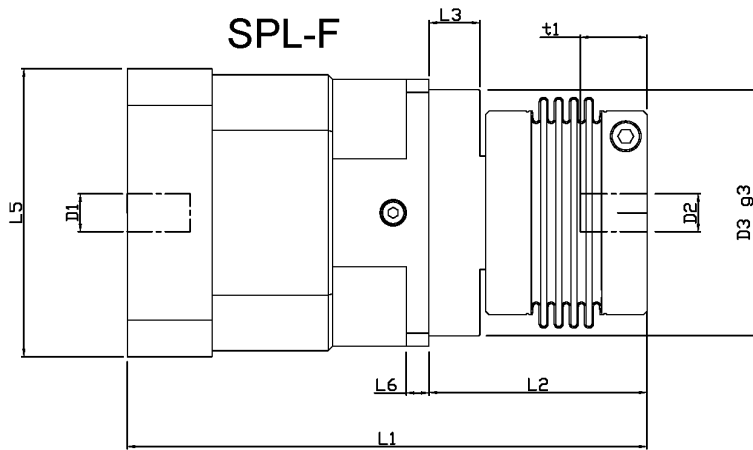

SPL-F		60		75		100		140		180	
		mm	(in)	mm	(in)	mm	(in)	mm	(in)	mm	(in)
D1 max standard	motor shaft diameter	14	(0.551)	19	(0.748)	24	(0.945)	32	(1.260)	54	(2.126)
D1 max available*	motor shaft diameter	19	(0.748)	24	(0.945)	32	(1.26)	38	(1.496)	54	(2.126)
D1 max 2-stage	motor shaft diameter	14	(0.551)	19	(0.748)	24	(0.945)	34	(1.339)	38	(1.496)
D2 _{max} - FB	max output bore	28	(1.102)	38	(1.496)	50	(1.969)	64	(2.520)	85	(3.346)
D2 _{max} - FE	max output bore	26	(1.024)	38	(1.496)	46	(1.811)	56	(2.205)	-	-
D3 _{g6} - FB/E	pilot diameter	60	(2.362)	70	(2.756)	90	(3.543)	130	(5.118)	160	(6.299)
D4 _{FB/E}	bolt circle	68	(2.677)	85	(3.346)	120	(4.724)	165	(6.496)	215	(8.465)
D5 _{FB/E}	bolt hole	ø5.5		ø6.6		ø9		ø11		ø13	
L1 _{1-stage} - FB**	gearbox total length	169	(6.653)	196.5	(7.736)	223	(8.779)	280	(11.024)	304	(11.968)
L1 _{2-stage} - FB**	gearbox total length	196	(7.716)	223	(8.779)	247.5	(9.744)	330	(12.992)	327	(12.874)
L1 _{1-stage} - FE**	gearbox total length	171	(6.732)	196.5	(7.736)	226.5	(8.917)	290	(11.417)	-	-
L1 _{2-stage} - FE**	gearbox total length	198	(7.795)	223	(8.779)	251	(9.882)	340	(13.386)	-	-
L2 _{FB}	coupling length	76	(2.992)	83	(2.047)	105	(4.134)	117	(4.606)	112	(4.409)
L2 _{FE}	coupling length	79	(3.110)	94	(3.700)	104	(4.094)	125	(4.921)	-	-
L3 _{FB/E}	pilot height	20	(0.787)	20	(0.787)	30	(1.181)	30	(1.181)	14	(0.551)
L4 _{FB/E}	output flange size	65	(2.559)	76	(2.992)	101	(3.976)	141	(5.551)	180	(7.087)
L5**	gearbox thickness	70	(2.756)	81	(3.189)	106	(4.173)	146	(5.748)	200	(7.874)
L6 _{FB/E}	flange thickness	6	(0.236)	7	(0.276)	10	(0.394)	12	(0.472)	20	(0.787)
t1 _{min} - FB	min shaft engagement	21	(0.827)	26	(1.024)	32	(1.260)	33	(1.300)	59	(2.323)
t1 _{max} - FB	max shaft engagement	39	(1.535)	43	(1.693)	58	(2.165)	52	(2.047)	88	(3.465)
t1 _{min} - FE	min shaft engagement	22	(0.866)	28	(1.102)	34	(1.339)	36	(1.417)	-	-
t1 _{max} - FE	max shaft engagement	31.5	(1.240)	38.5	(1.516)	45	(1.772)	48.5	(1.909)	-	-

* for larger motor shaft diameters, please contact GAM ** depending on the motor, value can vary

Size	Tolerances (mm)	
	k6	g6
Over 6	+0.010	-0.005
Thru 10	+0.001	-0.014
Over 10	+0.012	-0.006
Thru 18	+0.001	-0.017
Over 18	+0.015	-0.007
Thru 30	+0.002	-0.020
Over 30	+0.018	-0.009
Thru 50	+0.002	-0.025
Over 50	+0.021	-0.010
Thru 80	+0.002	-0.029
Over 80	+0.025	-0.012
Thru 120	+0.003	-0.034
Over 120	+0.028	-0.014
Thru 180	+0.003	-0.037

TYPE CODES FOR SPL-F SERIES

Example: SPL - FE - 060 - 005 G - [115-201] - S111

Gearbox Series

SPL Series.

Gearbox Style

FB = Bellows coupling output
FE = Elastomer coupling output

Gearbox Size

060, 075, 100, 140, 180

Ratio

3, 4, 5, 7, 10, 12, 16, 20, 25, 35, 40, 50, 70, 100

Special Options

Assigned by GAM

Motor Mount Kit

Assigned by GAM

Options Available for This Product

G = Standard backlash and keyway in output coupling

C = Reduced backlash and keyway in output coupling

H = Standard backlash and no keyway in output coupling

A = Reduced backlash and no keyway in output coupling

Sold & Serviced By:

ELECTROMATE

Toll Free Phone (877) SERV098

Toll Free Fax (877) SERV099

www.electromate.com

sales@electromate.com



▶ HIGH PERFORMANCE: EPL SERIES

GAM can.

If you don't see exactly what you need, let us know. We can modify the EPL Series gearboxes to meet your needs. Page 4 provides a list of commonly requested modifications to give you a feel for our capabilities.

Our EPL Series is widely known as the best value on the market- tens of thousands of EPL's installed since 1998 in North America alone. That's because it offers the best quality available for the price point. We've added some features that make it unequalled in its class and ideal for most servo applications.

EPL Series enhancements include:

- A 50 mm frame size in our standard shaft version (-W) that is a drop-in for many gearboxes
- NEMA output version with oversized english shaft for improved performance
- Option for larger motor shafts

New output configurations include:

- EPL-A dimensions that drop in for popular planetary gearboxes on the market.
- EPL-F that features a flange output for a compact design and allows for easy connecting of mechanical elements such as pulleys and pinions.

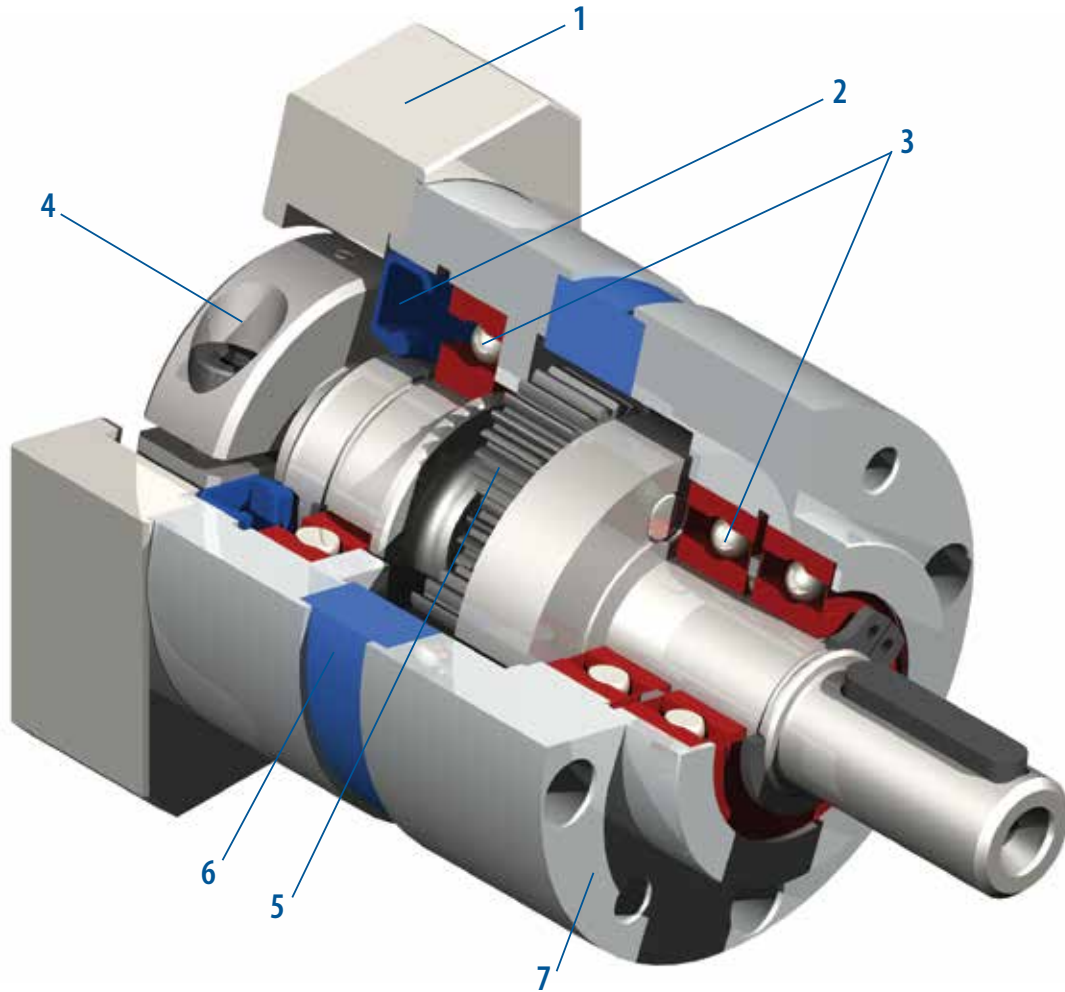

1. Adapter Plate

(Customized adapter plates for quick and easy motor mounting)

3. Angular Contact Bearings

(for high radial and axial loading)

6. Ring Gear

(Ring gear incorporated into housing)

4. Input Clamping Element

5. Planet Gears

(Precision honed gears)

7. Output Face

2. Seals
(Protective seals to isolate the gearbox)

Sold & Serviced By:

 **ELECTROMATE**

Toll Free Phone (877) SERV098

Toll Free Fax (877) SERV099

23 www.electromate.com

sales@electromate.com

▶ HIGH PERFORMANCE: EPL SERIES

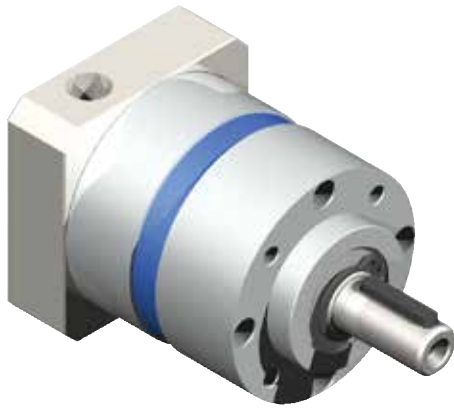

EPL-W

- GAM Metric Output Face
- Heavy Duty Output Bearings
- Ratios 3:1 to 1000:1
- Frame sizes from 50 mm to 150 mm
- Ready to mount to your motor

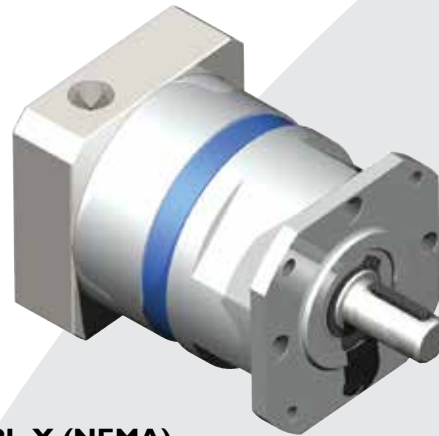

EPL-X (NEMA)

- NEMA output face with oversized english shaft
- Ratios 3:1 to 1000:1
- Frame sizes from NEMA 17 to 56
- Ready to mount to your motor

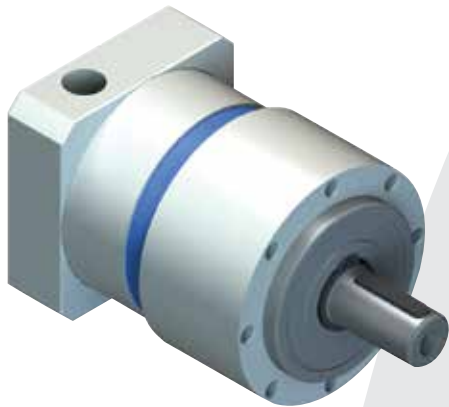

EPL-A

- Metric output dimensions match many other popular inline planetary gear reducers on the market.
- Ratios 3:1 to 1000:1
- Frame sizes from 50mm to 155mm
- Ready to mount to your motor

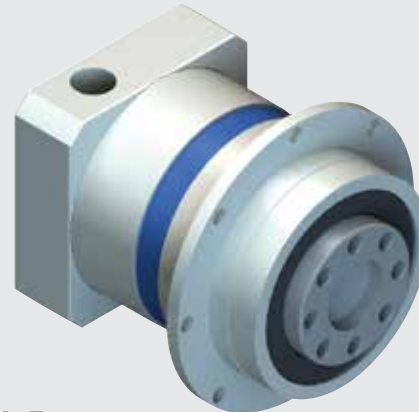

EPL-F

- Flange output
- Compact design
- Ratios 3:1 to 1000:1
- Ready to mount to your motor

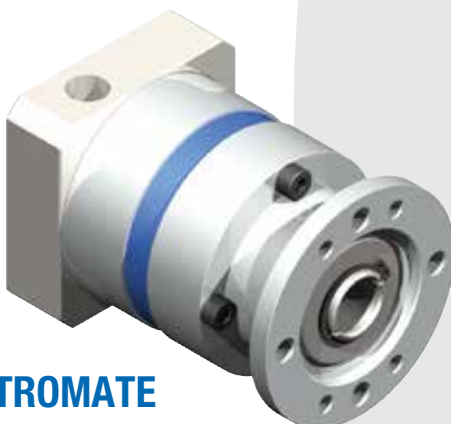

EPL-H Linear Mount

- Hollow output with zero backlash clamping ring
- A quick, simple, low cost solution used to mount onto any “off the shelf” linear belt or ball screw module.
- Ready to mount to your motor on the input
- Ready to mount to your module on the output
- For more information on Linear Mounts, refer to page 77.

Sold & Serviced By:



Toll Free Phone (877) SERV098

Toll Free Fax (877) SERV099

www.electromate.com

sales@electromate.com



EPL SERIES - EPL-W



EPL Series		50		64		84		118		150			
Stock Ratios		3, 5, 7, 10, 25, 50, 100 (Standard Input)										N/A	
All Ratios Available		1-stage: 3, 4, 5, 7, 10 2-stage: 12, 16, 20, 25, 35, 40, 50, 70, 100 3-stage: 120, 160, 200, 250, 350, 490, 700, 1000 (Consult GAM for other ratios)											
Nominal Output Torque (T_{2n})	Nm (lb-in)	3:1	5 (44)	20 (177)	40 (354)	100 (885)	230 (2036)						
		4, 5, 7:1	6.5 (58)	26 (230)	54 (478)	120 (1062)	310 (2744)						
		10, 100, 1000:1	5 (44)	16 (142)	40 (354)	105 (929)	180 (1593)						
		12:1	14 (124)	36 (319)	80 (708)	170 (1505)	272 (2407)						
		all other ratios	16 (142)	42 (372)	100 (885)	210 (1859)	340 (3009)						
Max Acceleration Output Torque (T_{2B})	Nm (lb-in)	3:1	10 (89)	36 (319)	70 (620)	180 (1593)	360 (3186)						
		4, 5, 7:1	13 (115)	44 (389)	100 (885)	200 (1770)	460 (4071)						
		10, 100, 1000:1	10 (89)	24 (212)	75 (664)	180 (1593)	340 (3009)						
		12:1	17.5 (155)	45 (398)	100 (885)	215 (1903)	360 (3186)						
		all other ratios	20 (177)	52 (460)	125 (1106)	255 (2257)	460 (4071)						
Emergency Output Torque (T_{2not})	Nm (lb-in)	3:1	20 (177)	72 (637)	160 (1416)	200 (1770)	860 (7612)						
		4, 5, 7:1	26 (230)	84 (743)	216 (1912)	480 (4248)	1000 (8851)						
		10, 100, 1000:1	20 (177)	62 (549)	160 (1416)	410 (3629)	800 (7081)						
		12:1	28 (248)	72 (637)	160 (1416)	400 (3540)	860 (7612)						
		all other ratios	32 (283)	84 (743)	216 (1912)	480 (4248)	1000 (8851)						
Nominal Speed (n_{1n})	RPM	-	3500	3500	3000	2500	2500						
Max Speed (n_{1max})	RPM	-	6000	6000	6000	5000	4500						
Standard Output Backlash (j)	arcmin	1-stage	<16	<10	<10	<8	<8						
		2-stage	<20	<14	<14	<12	<12						
		3-stage	-	<18	<18	<16	<16						
Allowable Radial Load (F_{rad}) 1	N (lbs)	-	650 (146)	1900 (428)	2800 (630)	5000 (1125)	7500 (1688)						
Allowable Axial Load (F_{axial})	N (lbs)	-	700 (158)	1500 (338)	2500 (563)	4500 (1013)	6000 (1350)						
Torsional Stiffness (C_{t21})	Nm/arcmin (lb-in/arcmin)	10,100,1000	0.60 (5.3)	1.3 (11.5)	3.4 (30.1)	8.3 (73.5)	22 (194.7)						
		7,70,700	0.78 (6.9)	1.7 (15)	4.8 (42.5)	13.6 (120.4)	27 (239)						
		all other ratios	0.90 (8.0)	2.4 (21.2)	7.1 (62.8)	17.2 (152.2)	33 (292.1)						
Weight (m)	kg (lbs)	1-stage	0.4 (0.9)	1.0 (2.2)	2.3 (5.1)	5.8 (12.8)	10.0 (22.1)						
		2-stage	0.5 (1.1)	1.3 (2.9)	3.1 (6.8)	7.9 (17.4)	12.5 (27.6)						
		3-stage	-	1.6 (3.5)	3.9 (8.6)	10.0 (22.1)	15.0 (33.1)						
Noise Level (L_{pk})	dB(A)	-	<64	<66	<68	<70	<72						
Mass Moment of Inertia (J_1)	kg cm ² (lb-in ²) (lb-in ²)	3:1	0.06 (0.021)	0.45 (0.154)	1.37 (0.468)	6.54 (2.235)	12.23 (4.179)						
		4:1, 12:1, 16:1	0.04 (0.014)	0.38 (0.130)	1.14 (0.390)	4.8 (1.640)	7.65 (2.614)						
		5:1, 20:1, 25:1	0.04 (0.014)	0.36 (0.123)	1.05 (0.359)	4.05 (1.384)	6.24 (2.132)						
		7:1, 35:1	0.04 (0.014)	0.35 (0.120)	0.97 (0.331)	3.4 (1.162)	4.7 (1.606)						
		10:1, 40:1 - 100:1	0.04 (0.014)	0.34 (0.116)	0.93 (0.318)	3.1 (1.059)	3.8 (1.299)						
		120:1 - 1000:1	(0.000)	0.34 (0.116)	0.93 (0.318)	3.12 (1.066)	3.9 (1.333)						
Efficiency at Load	1-stage: 94% 2-stage: 92% 3-stage: 90%												
Service Life	> 30,000 hours												
Lubrication	Mineral Grease EPO												
Protection Rating	IP 64												
Operating Temperature Range	-20°C to 90°C												

1) Load applied at center of output shaft @100 RPM

Sold & Serviced By:
ELECTROMATE
 Toll Free Phone (877) SERV098
 Toll Free Fax (877) SERV099
www.electromate.com
sales@electromate.com

EPL-W

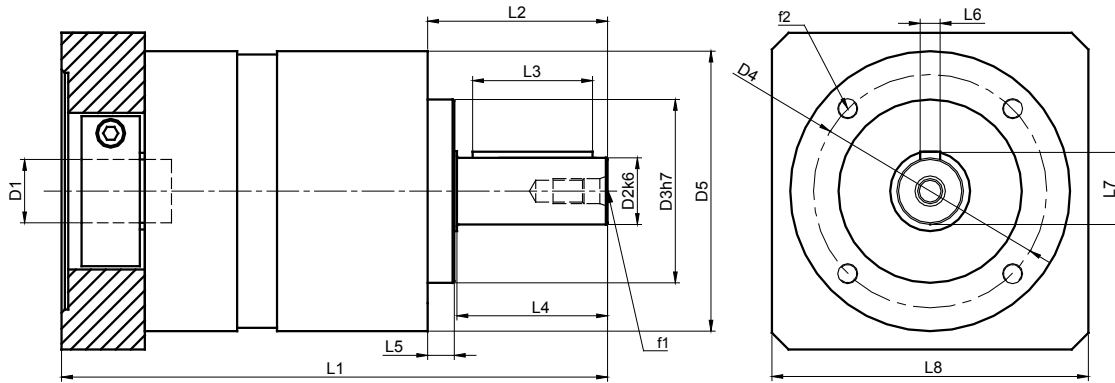

EPL-W Series		50		64		84		118		150	
		mm	(in)	mm	(in)	mm	(in)	mm	(in)	mm	(in)
D1 ^{max standard*}	motor shaft diameter	11	(0.433)	14	(0.551)	19	(0.748)	24	(0.945)	28	(1.102)
D1 ^{max available*}	motor shaft diameter	14	(0.551)	16	(0.63)	24	(0.945)	32	(1.26)	38	(1.496)
D2 ^{k6}	output shaft diameter	12	(0.472)	14	(0.551)	20	(0.787)	25	(0.984)	40	(1.575)
D3 ^{h7}	pilot diameter	35	(1.378)	40	(1.575)	55	(2.165)	80	(3.15)	110	(4.331)
D4	bolt circle	44	(1.732)	52	(2.047)	70	(2.756)	100	(3.937)	130	(5.118)
D5	housing diameter	50	(1.969)	64	(2.52)	84	(3.307)	118	(4.646)	150	(5.906)
f1	shaft thread	M4x8		M5x12		M6x16		M10x22		M10 x 22	
f2	mounting holes	M4x6		M5x12		M6x14		M8x18		M10x20	
L1 1-STAGE**	gearbox total length	93 (3.661)		117 (4.606)		162 (6.378)		199 (7.835)		265 (10.433)	
L1 2-STAGE**		109 (4.291)		139 (5.472)		195 (7.677)		239 (9.409)		305 (12.008)	
L1 3-STAGE**		-		161 (6.339)		228 (8.976)		280 (11.024)		346 (13.622)	
L2	shaft length	24.5	(0.965)	39	(1.535)	54	(2.126)	61	(2.402)	81	(3.189)
L3	key length	16	(0.63)	25	(0.984)	36	(1.417)	45	(1.772)	60	(2.362)
L4	usable shaft length	18	(0.709)	30	(1.181)	45	(1.772)	50	(1.969)	70	(2.756)
L5	pilot height	4	(0.157)	8	(0.315)	8	(0.315)	10	(0.394)	10	(0.394)
L6	key width	4	(0.157)	5	(0.197)	6	(0.236)	8	(0.315)	12	(0.472)
L7	key height	13.5	(0.531)	16	(0.63)	22.5	(0.886)	28	(1.102)	43	(1.693)
L8**	adapter size	50	(1.969)	70	(2.756)	90	(3.543)	120	(4.724)	150	(5.906)

* for larger motor shaft diameters, please contact GAM ** depending on the motor, value can vary



Recommended Output Coupling (if necessary)

	metal bellows	KLC-25	KLC-50	KLC-125	KM-270	KM-400
elastomer	EKM-45	EKM-60	EKM-150	EKM-300	EKM-400	EKM-400

TYPE CODES FOR EPL SERIES (EPL-W)

Example: EPL - W - 084 - 005 G - [115 - A01] - S111

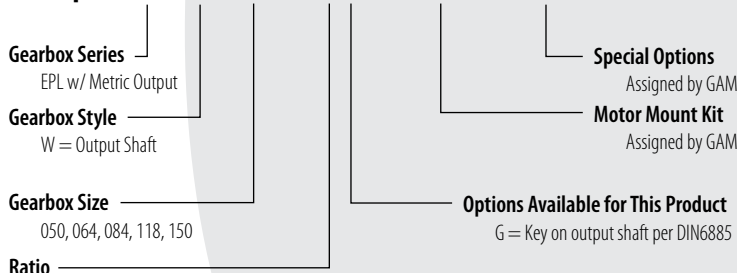

Tolerances (mm)		
Size	k6	h7
Over 10	+0.012	0
Thru 18	+0.001	-0.018
Over 18	+0.015	0
Thru 30	+0.002	-0.021
Over 30	+0.018	0
Thru 50	+0.002	-0.025
Over 50	+0.021	0
Thru 80	+0.002	-0.030
Over 80	+0.025	0
Thru 120	+0.003	-0.035

Sold & Serviced By:



ELECTROMATE

3, 4, 5, 7, 10, 12, 16, 20, 25, 35, 40, 50, 70, 100, 200, 160, 200, 250, 350, 490, 700, 000=1000

Toll Free Phone (877) SERV098

Toll Free Fax (877) SERV099

www.electromate.com

sales@electromate.com



EPL SERIES - EPL-X (NEMA)



NEMA-X Series		17	23	34	42	56	
Stock Ratios		N/A	3, 5, 7, 10, 25, 50, 100		N/A	N/A	
All Ratios Available		1-stage: 3, 4, 5, 7, 10 2-stage: 12, 16, 20, 25, 35, 40, 50, 70, 100 3-stage: 120, 160, 200, 250, 350, 490, 700, 1000					
Nominal Output Torque (T_{2n})	Nm (lb-in)	3:1	5 (44)	20 (177)	40 (354)	100 (885)	100 (885)
		4, 5, 7:1	6.5 (58)	26 (230)	54 (478)	120 (1062)	120 (1062)
		10, 100, 1000:1	5 (44)	16 (142)	40 (354)	105 (929)	105 (929)
		12:1	14 (124)	36 (319)	80 (708)	170 (1505)	170 (1505)
		all other ratios	16 (142)	42 (372)	100 (885)	210 (1859)	210 (1859)
Max Accel. Torque (T_{2B})	Nm (lb-in)	3:1	10 (89)	36 (319)	70 (620)	180 (1593)	180 (1593)
		4, 5, 7:1	13 (115)	44 (389)	100 (885)	200 (1770)	200 (1770)
		10, 100, 1000:1	10 (89)	24 (212)	75 (664)	180 (1593)	180 (1593)
		12:1	17.5 (155)	45 (398)	100 (885)	215 (1903)	215 (1903)
		all other ratios	20 (177)	52 (460)	125 (1106)	255 (2257)	255 (2257)
Emergency Output Torque (T_{2not})	Nm (lb-in)	3:1	20 (177)	72 (637)	160 (1416)	200 (1770)	200 (1770)
		4, 5, 7:1	26 (230)	84 (743)	216 (1912)	480 (4248)	480 (4248)
		10, 100, 1000:1	20 (177)	62 (549)	160 (1416)	410 (3629)	410 (3629)
		12:1	28 (248)	72 (637)	160 (1416)	400 (3540)	400 (3540)
		all other ratios	32 (283)	84 (743)	216 (1912)	480 (4248)	480 (4248)
Nominal Speed (n_{1n})	RPM	-	3500	3500	3000	2500	2500
Max Input Speed (n_{1max})		6000	6000	6000	5000	5000	
Standard Output Backlash (j)	arcmin	1-stage	< 20	< 10	< 10	< 8	< 8
		2-stage	< 24	< 14	< 14	< 12	< 12
		3-stage	< 30	< 18	< 18	< 16	< 16
Allowable Radial Load (F_{rad}) ¹⁾	N (lbs)	-	375 (84)	450 (101)	900 (203)	2175 (489)	2175 (489)
Allowable Axial Load (F_{axial})	N (lbs)	-	300 (68)	420 (95)	650 (146)	1375 (309)	1375 (309)
Torsional Stiffness (C_{21})	Nm/arcmin (lb-in/arcmin)	10,100,1000	Contact GAM	1.3 (11.5)	3.4 (30.1)	8.3 (73.5)	8.3 (73.5)
		7,70,700	Contact GAM	1.7 (15)	4.8 (42.5)	13.6 (120.4)	13.6 (120.4)
		all other ratios	Contact GAM	2.4 (21.2)	7.1 (62.8)	17.2 (152.2)	17.2 (152.2)
Weight (m)	kg (lbs)	1-stage	0.4 (0.88)	1.0 (2.2)	2.3 (5.1)	5.8 (12.8)	5.8 (12.8)
		2-stage	0.5 (1.1)	1.3 (2.9)	3.1 (6.8)	7.9 (17.4)	7.9 (17.4)
		3-stage	0.6 (1.32)	1.6 (3.5)	3.9 (8.6)	10.0 (22.1)	10.0 (22.1)
Noise Level (L_{pA})	dB(A)	-	< 60	< 66	< 68	< 70	< 70
Mass Moment of Inertia (J_1)	kg cm ² (lb-in ²)	3:1	0.0144 (0.005)	0.45 (0.154)	1.37 (0.468)	6.54 (2.235)	6.54 (2.235)
		4:1, 12:1, 16:1	0.0096 (0.003)	0.38 (0.130)	1.14 (0.390)	4.8 (1.640)	4.8 (1.640)
		5:1, 20:1, 25:1	0.0096 (0.003)	0.36 (0.123)	1.05 (0.359)	4.05 (1.384)	4.05 (1.384)
		7:1, 35:1	0.0152 (0.005)	0.35 (0.120)	0.97 (0.331)	3.4 (1.162)	3.4 (1.162)
		10:1, 40:1 - 100:1	0.0078 (0.003)	0.34 (0.116)	0.93 (0.318)	3.1 (1.059)	3.1 (1.059)
		120:1 - 1000:1	0.0078 (0.003)	0.34 (0.116)	0.93 (0.318)	3.12 (1.066)	3.12 (1.066)
Efficiency at Load	1-stage: 94% 2-stage: 92% 3-stage: 90%						
Service Life	> 30,000 hours						
Lubrication	Mineral Grease EP0						
Protection Rating	IP 64						
Operating Temperature Range	-20°C to 90°C						

1) Load applied at center of output shaft @100 RPM

Sold & Serviced By:
ELECTROMATE
 Toll Free Phone (877) SERV098
 Toll Free Fax (877) SERV099
www.electromate.com
sales@electromate.com

EPL-X

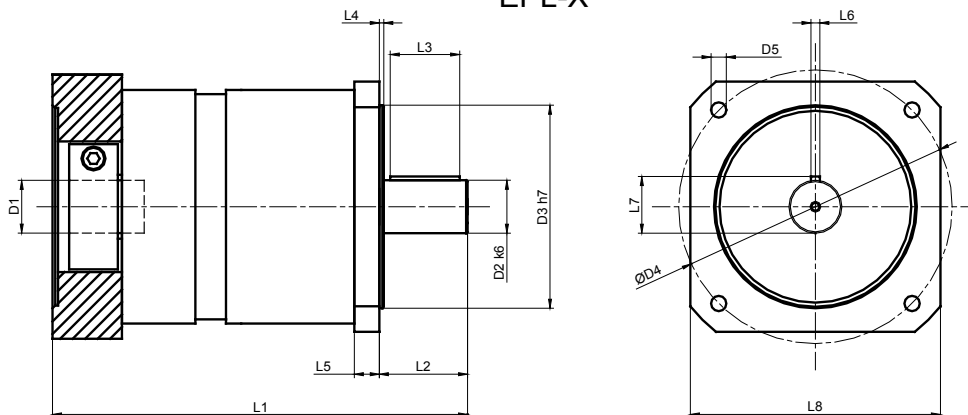

NEMA-X Series		17		23		34		42		56	
		mm	(in)	mm	(in)	mm	(in)	mm	(in)	mm	(in)
D1 _{max standard} *	motor shaft diameter	11	(0.433)	14	(0.551)	19	(0.748)	24	(0.945)	24	(0.945)
D1 _{max available} *	motor shaft diameter	-	(-)	16	(0.63)	24	(0.945)	32	(1.26)	32	(1.26)
D2 k6	output shaft diameter	9.525	(0.375)	12.7	(0.5)	19.050	(0.75)	25	(0.984)	25	(0.984)
D3 h7	pilot diameter	21.97	(0.865)	38.1	(1.5)	73	(2.874)	55.55	(2.187)	114.300	(4.50)
D4	bolt circle	43.8	(1.724)	66.7	(2.626)	98.400	(3.874)	125.7	(4.949)	177.800	(7.000)
D5	mounting holes	3.25	(0.128)	5	(0.197)	5.5	(0.217)	7.1	(0.28)	10.200	(0.402)
L1 1-STAGE**	gearbox total length	108	(4.252)	111	(4.37)	147	(5.787)	199	(7.835)	199	(7.835)
L1 2-STAGE**		124	(4.882)	133	(5.236)	180	(7.087)	239	(9.409)	239	(9.409)
L1 3-STAGE**		139.5	(5.492)	155	(6.102)	213	(8.386)	280	(11.024)	280	(11.024)
L2	shaft length	25.4	(1.000)	25.4	(1.000)	31.8	(1.252)	42	(1.654)	41	(1.614)
L3	key length	-	(-)	19.05	(0.75)	25.4	(1)	38	(1.496)	32	(1.26)
L4	pilot height	1.6	(0.063)	1.6	(0.063)	1.7	(0.067)	2.4	(0.094)	4	(0.157)
L5	flange thickness	4.9	(0.193)	5	(0.197)	10	(0.394)	19	(0.748)	20	(0.7874)
L6	key width	-	(-)	3.175	(0.125)	4.78	(0.188)	8	(0.315)	8	(0.315)
L7	key height / flat height	9.14	(0.36)	14.22	(0.56)	21.290	(0.838)	28	(1.102)	28	(1.102)
L8	flange size	40	(1.575)	65	(2.559)	90	(3.543)	120	(4.724)	145	(5.709)

* for larger motor shaft diameters, please contact GAM **depending on the motor, value can vary *** long motor shafts can be accommodated, but overall gearbox length will grow



Recommended Output Coupling (if necessary)

	KLC-25	KLC-50	KLC-125	KM-270	KM-400
metal bellows					
elastomer	EKM-20	EKM-60	EKM-150	EKM-300	EKM-400

TYPE CODES FOR EPL SERIES (EPL-X (NEMA))

Example: EPL - X23 - 005 G - [115 - A01] - S111

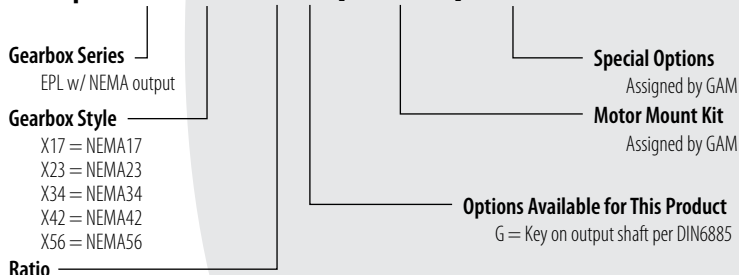

Tolerances (mm)		
Size	k6	h7
Over 10	+0.012	0
Thru 18	+0.001	-0.018
Over 18	+0.015	0
Thru 30	+0.002	-0.021
Over 30	+0.018	0
Thru 50	+0.002	-0.025
Over 50	+0.021	0
Thru 80	+0.002	-0.030
Over 80	+0.025	0
Thru 120	+0.003	-0.035

Sold & Serviced By:

ELECTROMATE

Toll Free Phone (877) SERV098
Toll Free Fax (877) SERV099
www.electromate.com
sales@electromate.com



EPL SERIES - EPL-A



EPL-A Series		50		70		90		120		155	
All Ratios Available		1stage: 3, 4, 5, 7, 10 2stage: 12, 16, 20, 25, 35, 40, 50, 70, 100 3stage: 120, 160, 200, 250, 350, 490, 700, 1000 (Consult GAM for other ratios)									
Nominal Output Torque (T_{2n})	Nm (lb-in)	3:1	5 (44)	20 (177)	40 (354)	100 (885)	230 (2036)				
		4, 5, 7:1	6.5 (58)	26 (230)	54 (478)	120 (1062)	310 (2744)				
		10, 100, 1000:1	5 (44)	16 (142)	40 (354)	105 (929)	180 (1593)				
		12:1	14 (124)	36 (319)	80 (708)	170 (1505)	272 (2407)				
		all other ratios	16 (142)	42 (372)	100 (885)	210 (1859)	340 (3009)				
Max Acceleration Output Torque (T_{2B})	Nm (lb-in)	3:1	10 (89)	36 (319)	70 (620)	180 (1593)	360 (3186)				
		4, 5, 7:1	13 (115)	44 (389)	100 (885)	200 (1770)	460 (4071)				
		10, 100, 1000:1	10 (89)	24 (212)	75 (664)	180 (1593)	340 (3009)				
		12:1	17.5 (155)	45 (398)	100 (885)	215 (1903)	360 (3186)				
		all other ratios	20 (177)	52 (460)	125 (1106)	255 (2257)	460 (4071)				
Emergency Output Torque (T_{2not})	Nm (lb-in)	3:1	20 (177)	72 (637)	160 (1416)	200 (1770)	860 (7612)				
		4, 5, 7:1	26 (230)	84 (743)	216 (1912)	480 (4248)	1000 (8851)				
		10, 100, 1000:1	20 (177)	62 (549)	160 (1416)	410 (3629)	800 (7081)				
		12:1	28 (248)	72 (637)	160 (1416)	400 (3540)	860 (7612)				
		all other ratios	32 (283)	84 (743)	216 (1912)	480 (4248)	1000 (8851)				
Nominal Speed (n_{1n})	RPM	-	3500	3500	3000	2500	2500				
Max Speed (n_{1max})	RPM	-	6000	6000	6000	5000	4500				
Standard Output Backlash (j)	arcmin	1stage	<16	<10	<10	<8	<8				
		2stage	<20	<14	<14	<12	<12				
		3stage	-	<18	<18	<16	<16				
Allowable Radial Load (F_{rad1})	N (lbs)	-	650 (146)	1550 (348)	2400 (540)	4600 (1034)	7500 (1686)				
Allowable Axial Load (F_{axial})	N (lbs)	-	700 (158)	1450 (326)	1900 (427)	4000 (899)	6000 (1349)				
Torsional Stiffness (C_{21})	Nm/arcmin (lbin/arcmin)	10,100,1000	0.60 (5.3)	1.3 (11.5)	3.4 (30.1)	8.3 (73.5)	22 (194.7)				
		7,70,700	0.78 (6.9)	1.7 (15)	4.8 (42.5)	13.6 (120.4)	27 (239)				
		all other ratios	0.90 (8.0)	2.4 (21.2)	7.1 (62.8)	17.2 (152.2)	33 (292.1)				
Weight (m)	kg (lbs)	1stage	0.4 (0.9)	1 (2.2)	2.3 (5.1)	5.8 (12.8)	10 (22.1)				
		2stage	0.5 (1.1)	1.3 (2.9)	3.1 (6.8)	7.9 (17.4)	12.5 (27.6)				
		3stage	-	1.6 (3.5)	3.9 (8.6)	10.0 (22.1)	15 (33.1)				
Noise Level (L_{pk})	dB(A)	-	<64	<66	<68	<70	<72				
Mass Moment of Inertia (J_1)	kg cm ² (lb-in ²)	3:1	0.06 (0.021)	0.45 (0.154)	1.37 (0.468)	6.54 (2.235)	12.23 (4.179)				
		4:1, 12:1, 16:1	0.04 (0.014)	0.38 (0.13)	1.14 (0.390)	4.8 (1.640)	7.65 (2.614)				
		5:1, 20:1, 25:1	0.04 (0.014)	0.36 (0.123)	1.05 (0.359)	4.05 (1.384)	6.24 (2.132)				
		7:1, 35:1	0.04 (0.014)	0.35 (0.12)	0.97 (0.331)	3.4 (1.162)	4.7 (1.606)				
		10:1, 40:1 - 100:1	0.04 (0.014)	0.34 (0.116)	0.93 (0.318)	3.1 (1.059)	3.8 (1.299)				
		120:1 - 1000:1	0 0	0.34 (0.116)	0.93 (0.318)	3.12 (1.066)	3.9 (1.333)				
Efficiency at Load	1stage: 94% 2stage: 92% 3stage: 90%										
Service Life	> 30,000 hours										
Lubrication	Mineral Grease EPO										
Protection Rating	IP 64										
Operating Temperature Range	-20°C to 90°C										

Sold & Serviced By: **ELECTROMATE**

Toll Free Phone (877) SERV098
 Toll Free Fax (877) SERV099
www.electromate.com
sales@electromate.com

EPL-A

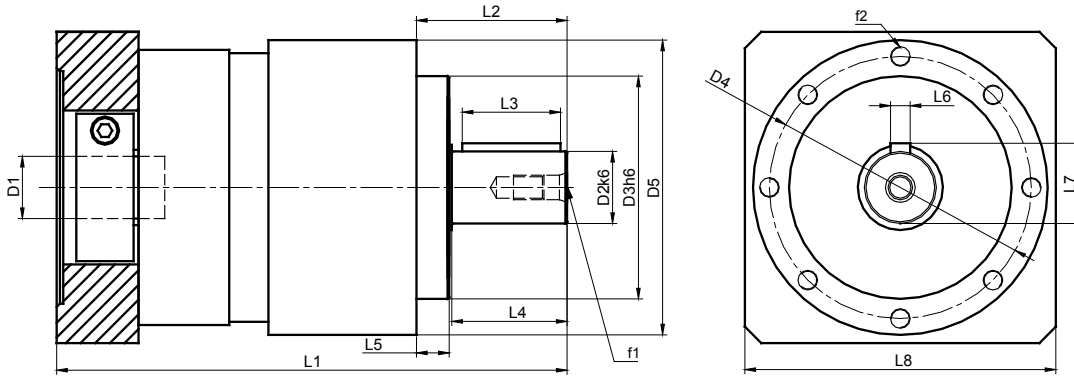

EPL-A Series		50		70		90		120		155	
		mm	(in)	mm	(in)	mm	(in)	mm	(in)	mm	(in)
D1 _{max standard} *	motor shaft diameter	11	(0.433)	14	(0.551)	19	(0.748)	24	(0.945)	28	(1.102)
D1 _{max available} *	motor shaft diameter	14	(0.551)	16	(0.630)	24	(0.945)	32	(1.260)	38	(1.496)
D2 k6	output shaft diameter	12	(0.472)	16	(0.630)	22	(0.866)	32	(1.260)	40	(1.575)
D3h6	pilot diameter	35	(1.378)	52	(2.047)	68	(2.677)	90	(3.543)	120	(4.724)
D4	Bolt Circle	44	(1.732)	62	(2.441)	80	(3.150)	108	(4.252)	140	(5.512)
D5	Housing Diameter	50	(1.968)	70	(2.756)	90	(3.543)	118	(4.646)	155	(6.102)
f1	Shaft Thread	M4x8		M5x17		M8x25		M12x37		M16x45	
f2	Mounting Holes	(8x) M4x6		(8x) M5x12		(8x) M6x14		(8x) M8x18		(8x) M10x24	
L1 1-STAGE**	gearbox total length	93	(3.661)	130	(5.118)	164	(6.457)	222	(8.740)	300	(11.811)
L1 2-STAGE**		109	(4.291)	152	(5.984)	196	(7.717)	263	(10.354)	341	(13.425)
L1 3-STAGE**		-	-	174	(6.850)	229	(9.016)	304	(11.968)	382	(15.039)
L2	Shaft length	24.5	(0.965)	36	(1.417)	46	(1.811)	70	(2.756)	94	(3.701)
L3	Key Length	16	(0.630)	25	(0.984)	30	(1.181)	50	(1.968)	70	(2.756)
L4	Useable Shaft Length	18	(0.709)	28	(1.102)	35	(1.378)	58	(2.283)	82	(3.228)
L5	Pilot Height	4	(0.157)	5.5	(0.217)	9	(0.354)	7	(0.276)	5.5	(0.217)
L6	Key Width	4	(0.157)	5	(0.197)	6	(0.236)	10	(0.394)	12	(0.472)
L7	Key Height	13.5	(0.531)	18	(0.709)	24.5	(0.965)	35	(1.378)	43	(1.693)
L8**	Adapter Size	50	(1.968)	70	(2.756)	90	(3.543)	120	(4.724)	150	(5.905)

* for larger motor shaft diameters, please contact GAM **depending on the motor, value can vary *** longer motor shafts can be accommodated, but overall gearbox length will grow



Recommended Output Coupling (if necessary)

	KLC-25	KLC-50	KLC-125	KM-270	KM-400
metal bellows	KLC-25	KLC-50	KLC-125	KM-270	KM-400
elastomer	EKM-20	EKM-60	EKM-150	EKM-300	EKM-400

TYPE CODES FOR EPL SERIES (EPL-A)

Example: EPL - A - 090 - 005 G - [115 - A01] - S111

Gearbox Series

EPL w/ Popular Metric Output Dimensions

Gearbox Style

A= Output Shaft

Gearbox Size

050, 070, 090, 120, 155

Special Options

Assigned by GAM

Motor Mount Kit

Assigned by GAM

Options Available for This Product

G = Key on output shaft per DIN6885

Tolerances (mm)

Size	k6	h6
Over 10	+0.012	0
Thru 18	+0.001	-0.011
Over 18	+0.015	0
Thru 30	+0.002	-0.013
Over 30	+0.018	0
Thru 50	+0.002	-0.016
Over 50	+0.021	0
Thru 80	+0.002	-0.019
Over 80	+0.025	0
Thru 120	+0.003	-0.022

Sold & Serviced By:

ELECTROMATE
Ratio

Toll Free Phone (877) SERV098 3, 4, 5, 7, 10, 12, 16, 20, 25, 35, 40, 50, 70, 100,

Toll Free Fax (877) SERV099 120, 160, 200, 250, 350, 490, 700, 000=1000

www.electromate.com

sales@electromate.com



EPL SERIES - EPL-F

EPL-F Series			64	90	110
All Ratios Available			1-Stage: 3, 4, 5, 7, 10 2-Stage: 12, 16, 20, 25, 35, 40, 50, 70, 100 3-Stage: 120, 160, 200, 250, 350, 490, 700, 1000		
Nominal Output Torque (T_{2n})	Nm (lb-in)	3:1	20 (177)	40 (354)	100 (885)
		4, 5, 7:1	26 (230)	54 (478)	120 (1062)
		10, 100, 1000:1	16 (142)	40 (354)	105 (929)
		12:1	36 (319)	80 (708)	170 (1505)
		all other ratios	42 (372)	100 (885)	210 (1859)
Max Acceleration Output Torque (T_{2B})	Nm (lb-in)	3:1	36 (319)	70 (620)	180 (1593)
		4, 5, 7:1	44 (389)	100 (885)	200 (1770)
		10, 100, 1000:1	24 (212)	75 (664)	180 (1593)
		12:1	45 (398)	100 (885)	215 (1903)
		all other ratios	52 (460)	125 (1106)	255 (2257)
Emergency Output Torque (T_{2not})	Nm (lb-in)	3:1	72 (637)	160 (1416)	200 (1770)
		4, 5, 7:1	84 (743)	216 (1912)	480 (4248)
		10, 100, 1000:1	62 (549)	160 (1416)	410 (3629)
		12:1	72 (637)	160 (1416)	400 (3540)
		all other ratios	84 (743)	216 (1912)	480 (4248)
Nominal Speed (n_{1n})	RPM	-	3500	3000	2500
Max Speed (n_{1max})	RPM	-	6000	6000	5000
Standard Output Backlash (j)	arcmin	1stage	< 10	< 10	< 8
		2stage	< 14	< 14	< 12
		3stage	< 18	< 18	< 16
Allowable Radial Load (F_{rad}) 1	N (lbs)	-	1200 (270)	2000 (450)	2100 (472)
Allowable Axial Load (F_{axial})	N (lbs)	-	800 (180)	1000 (225)	1400 (315)
Torsional Stiffness (C_{21})	Nm/arcmin (lbin/arc-min)	10,100,1000	1.3 (11.5)	3.4 (30.1)	8.3 (73.5)
		7,70,700	1.7 (15)	4.8 (42.5)	13.6 (120.4)
		all other ratios	2.4 (21.2)	7.1 (62.8)	17.2 (152.2)
Weight (m)	kg (lbs)	1stage	1 (2.2)	2.3 (5.1)	5.8 (12.8)
		2stage	1.3 (2.9)	3.1 (6.8)	7.9 (17.4)
		3stage	3.5 (3.9)	3.9 (8.6)	10.0 (22.1)
Noise Level (L_{pa})	dB(A)	-	<66	<68	<70
Mass Moment of Inertia (J_1)	kg cm ² (lb-in ²)	3:1	0.61 (0.208)	1.79 (0.612)	8.53 (2.915)
		4:1, 12:1, 16:1	0.5 (0.171)	1.47 (0.502)	6.11 (2.088)
		5:1, 20:1, 25:1	0.48 (0.164)	1.23 (0.420)	4.87 (1.664)
		7:1, 35:1	0.39 (0.133)	1.14 (0.390)	3.71 (1.268)
		10:1, 40:1 - 100:1	0.38 (0.130)	1.1 (0.376)	3.38 (1.155)
		120:1 - 1000:1	0.38 (0.130)	1.1 (0.376)	3.39 (1.158)
Efficiency at Load	1stage: 94% 2stage: 92% 3stage: 90%				
Service Life	> 30,000 hours				
Lubrication	Mineral Grease EPO				
Protection Rating	IP 64				
Operating Temperature Range	-20°C to 90°C				

Sold & Serviced By:
ELECTROMATE
 Toll Free Phone (877) SERV098
 Toll Free Fax (877) SERV099
www.electromate.com
sales@electromate.com

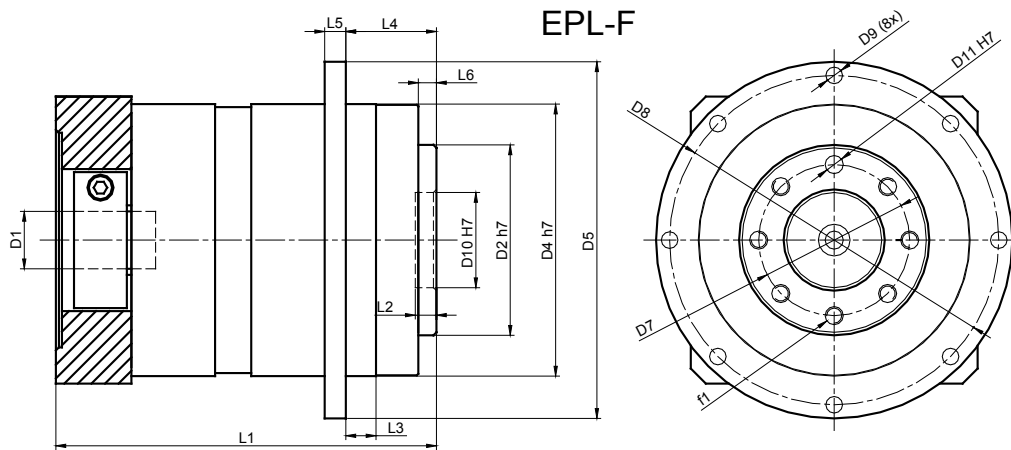

EPL-F Series		64		90		110	
		mm	(in)	mm	(in)	mm	(in)
D1 _{max standard} *	motor shaft diameter	14	(0.551)	19	(0.748)	24	(0.945)
D1 _{max available} *	motor shaft diameter	16	(0.630)	24	(0.945)	32	(1.260)
D2 h7	output flange diameter	40	(1.575)	63	(2.480)	80	(3.150)
D4 h7	pilot diameter	64	(2.520)	90	(3.543)	110	(4.331)
D5	flange diameter	86	(3.386)	118	(4.646)	145	(5.709)
D7	inner bolt circle	31.5	(1.240)	50	(1.968)	63	(2.480)
D8	outer bolt circle	79	(3.110)	109	(4.291)	135	(5.315)
D9	mounting hole diameter (8x)	4.5	(0.177)	5.5	(0.217)	5.5	(0.217)
D10 H7	flange pilot	20	(0.787)	31.5	(1.240)	40	(1.575)
D11 H7	dowel diameter	5	(0.197)	6	(0.236)	6	(0.236)
f1	flange tap	(7) M5x7		(7) M6x10		(7) M6x12	
L1 1-STAGE**	gearbox total length	93 (3.661)		126 (4.961)		150 (5.905)	
L1 2-STAGE**		113 (4.490)		158 (6.220)		190 (7.480)	
L1 3-STAGE**		129 (5.08)		191 (7.520)		231 (9.094)	
L2	flange pilot depth	4	(0.157)	6	(0.236)	6	(0.236)
L3	pilot height	7	(0.276)	10	(0.394)	10	(0.394)
L4	output length	19.5	(0.768)	30	(1.181)	29	(1.142)
L5	flange thickness	4	(0.157)	7	(0.276)	8	(0.315)
L6	output flange length	3	(0.118)	6	(0.236)	6	(0.236)

* for larger motor shaft diameters, please contact GAM ** depending on the motor, value can vary

TYPE CODES FOR EPL SERIES (EPL-F)

Example: EPL - F - 090 - 005 H - [115 - A01] - S111

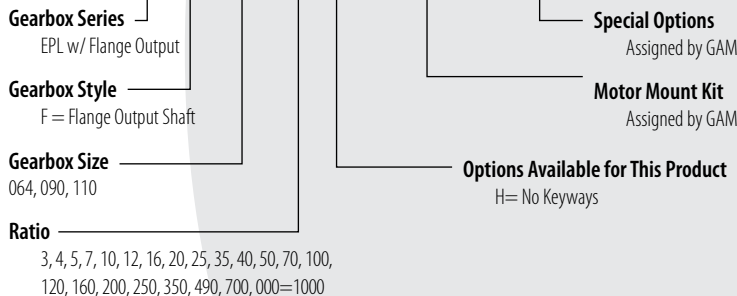

Size	Tolerances (mm)	
	h7	H7
Over 10	0	0.018
Thru 18	-0.018	0
Over 18	0	0.021
Thru 30	-0.021	0
Over 30	0	+0.025
Thru 50	-0.025	0
Over 50	0	+0.030
Thru 80	-0.030	0
Over 80	0	+0.035
Thru 120	-0.035	0

Sold & Serviced By:

ELECTROMATE

Toll Free Phone (877) SERV098

Toll Free Fax (877) SERV099

www.electromate.com

sales@electromate.com



▶ EPL SERIES: EPL-H



EPL Series		64	84	118	
Stock Ratios		3, 5, 7, 10, 25, 50, 100 (Standard Input)			
All Ratios Available		1-stage: 3, 4, 5, 7, 10			
		2-stage: 12, 16, 20, 25, 35, 40, 50, 70, 100			
		3-stage: 120, 160, 200, 250, 350, 490, 700, 1000			
Nominal Output Torque (T_{2n})	Nm (lb-in)	3:1, 10:1, 100:1, 1000:1	14 (124)	40 (354)	100 (885)
		4:1, 5:1, 7:1	26 (230)	50 (443)	120 (1062)
		all other ratios	36 (319)	64 (566)	165 (1460)
Max Accel Output Torque (T_{2B})	Nm (lb-in)	3:1, 10:1, 100:1, 1000:1	25 (221)	60 (531)	150 (1328)
		4:1, 5:1, 7:1	40 (354)	75 (664)	180 (1593)
		all other ratios	44 (389)	75 (664)	180 (1593)
Nominal Input Speed (n_{1n})	RPM	-	3500	3000	2500
Max Input Speed (n_{1max})	RPM	-	6000	6000	5000
Standard Output Backlash (j)	arcmin	3:1 - 10:1	< 10	< 10	< 8
		12:1 - 100:1	< 14	< 14	< 12
		120:1 - 1000:1	< 18	< 18	< 16
Weight (m)	kg (lb)	1-stage	1.0 (2.2)	2.3 (5.1)	5.8 (12.8)
		2-stage	1.3 (2.9)	3.1 (6.8)	7.9 (17.4)
		3-stage	1.6 (3.5)	3.9 (8.6)	10.0 (22.1)
Noise Level (L_{pA})	dB (A)	-	< 66	< 68	< 70
Mass Moment of Inertia (J_1)	kg cm ² (lb-in ²)	3:1	0.45 (0.154)	1.37 (0.468)	6.54 (2.235)
		4:1, 12:1, 16:1	0.38 (0.130)	1.14 (0.390)	4.8 (1.640)
		5:1, 20:1, 25:1	0.36 (0.123)	1.05 (0.359)	4.05 (1.384)
		7:1, 35:1	0.35 (0.120)	0.97 (0.331)	3.4 (1.162)
		10:1, 40:1 - 100:1	0.34 (0.116)	0.93 (0.318)	3.1 (1.059)
		120:1 - 1000:1	0.34 (0.116)	0.93 (0.318)	3.12 (1.066)
Efficiency at Load		1-stage: 92% 2-stage: 90% 3-stage: 88%			
Service Life		> 20,000 hours			
Lubrication		Mineral Grease EPO			
Protection Rating		IP 64			
Operating Temperature Range		-20°C to 90°C			

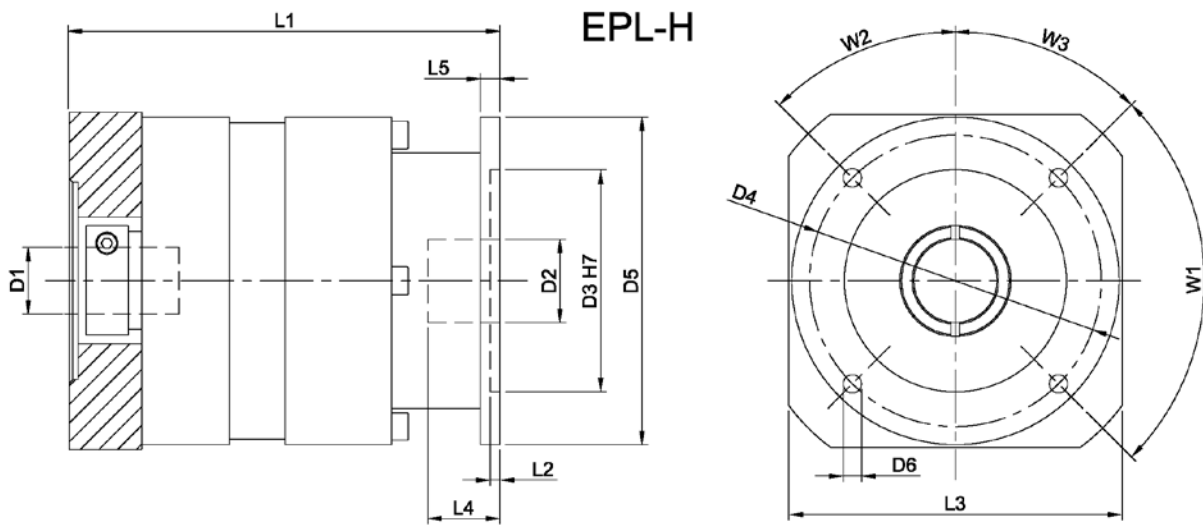

EPL Series		64		84		118	
		mm	(in)	mm	(in)	mm	(in)
D1 max standard*	motor shaft diameter	14	(0.551)	19	(0.748)	24	(0.945)
D1 max available*	motor shaft diameter	16	(0.63)	24	(0.945)	32	(1.26)
D2 max	output shaft diameter	16	(0.63)	20	(0.787)	30	(1.181)
D3 H7	pilot diameter	44	(1.732)	60	(2.362)	80	(3.15)
D4	bolt circle	55.5	(2.185)	73	(2.874)	105	(4.134)
D5	flange diameter	70	(2.756)	84	(3.307)	118	(4.646)
D6	mounting holes	5.5	(0.217)	5.5	(0.217)	6.6	(0.26)
L1 1-STAGE**	gearbox total length	98.5	(3.878)	122	(4.803)	155.5	(6.122)
L1 2-STAGE**		120.5	(4.744)	155	(6.102)	196	(7.717)
L1 3-STAGE**		142.5	(5.61)	188	(7.402)	236.5	(9.311)
L2	pilot depth	3.5	(0.138)	3.5	(0.138)	3.5	(0.138)
L3	flange size	70	(2.756)	90	(3.543)	120	(4.724)
L4	allowable shaft depth	28	(1.102)	30	(1.181)	27	(1.063)
L5	flange thickness	6	(0.236)	6	(0.236)	10	(0.394)
W1	bolt hole spacing	125°		4x 90°		4x 90°	
W2	hole angle 1	27.5°		67.5°		67.5°	
W3	hole angle 2	27.5°		22.5°		22.5°	

* for larger motor shaft diameters, please contact GAM ** depending on the motor, value can vary

TYPE CODES FOR EPL SERIES (EPL-H)

Example: EPL - H - 084 - 005 H - [115 - A01] - S111

Gearbox Series

EPL w/ Linear Mount
Output

Gearbox Style

H = Hollow Output Shaft

Gearbox Size

064, 084, 118

Ratio

3, 4, 5, 7, 10, 12, 16, 20, 25, 35, 40, 50, 70, 100,
120, 160, 200, 250, 350, 490, 700, 000 = 1000

Special Options

Assigned by GAM

Motor Mount Kit

Assigned by GAM

Options Available for This Product

H = No Keyways

Tolerances (mm)

Size	H7
Over 6	+0.015
Thru 10	0
Over 10	+0.018
Thru 18	0
Over 18	+0.021
Thru 30	0
Over 30	+0.025
Thru 50	0
Over 50	+0.030
Thru 80	0

Sold & Serviced By:

ELECTROMATE

Toll Free Phone (877) SERV098

Toll Free Fax (877) SERV099

www.electromate.com

sales@electromate.com



▶ HIGH PERFORMANCE: SSP SERIES

GAM can.

If you don't see exactly what you need, let us know. We can modify the SSP Series gearboxes to meet your needs. Page 4 provides a list of commonly requested modifications to give you a feel for our capabilities.

Our Stainless Steel Planetary (SSP) Series is an innovative washdown servo gearbox solution designed for food, medical or sanitary applications. It is a precision planetary gearbox outwardly constructed of 300-series stainless steel. The motor adapter plate, housing and shaft are all stainless steel. Viton® seals, stainless steel hardware and sealed interfaces provide outstanding corrosion resistance in all types of wet and caustic washdown environments. Ideal for any light or demanding servo application where corrosion resistance is a requirement, the SSP Series offers economy, high precision, and long lasting performance.

SSP Series benefits:

- All exposed surfaces stainless steel
- Frame sizes from 70 to 120 mm
- Ratios from 3:1 to 100:1

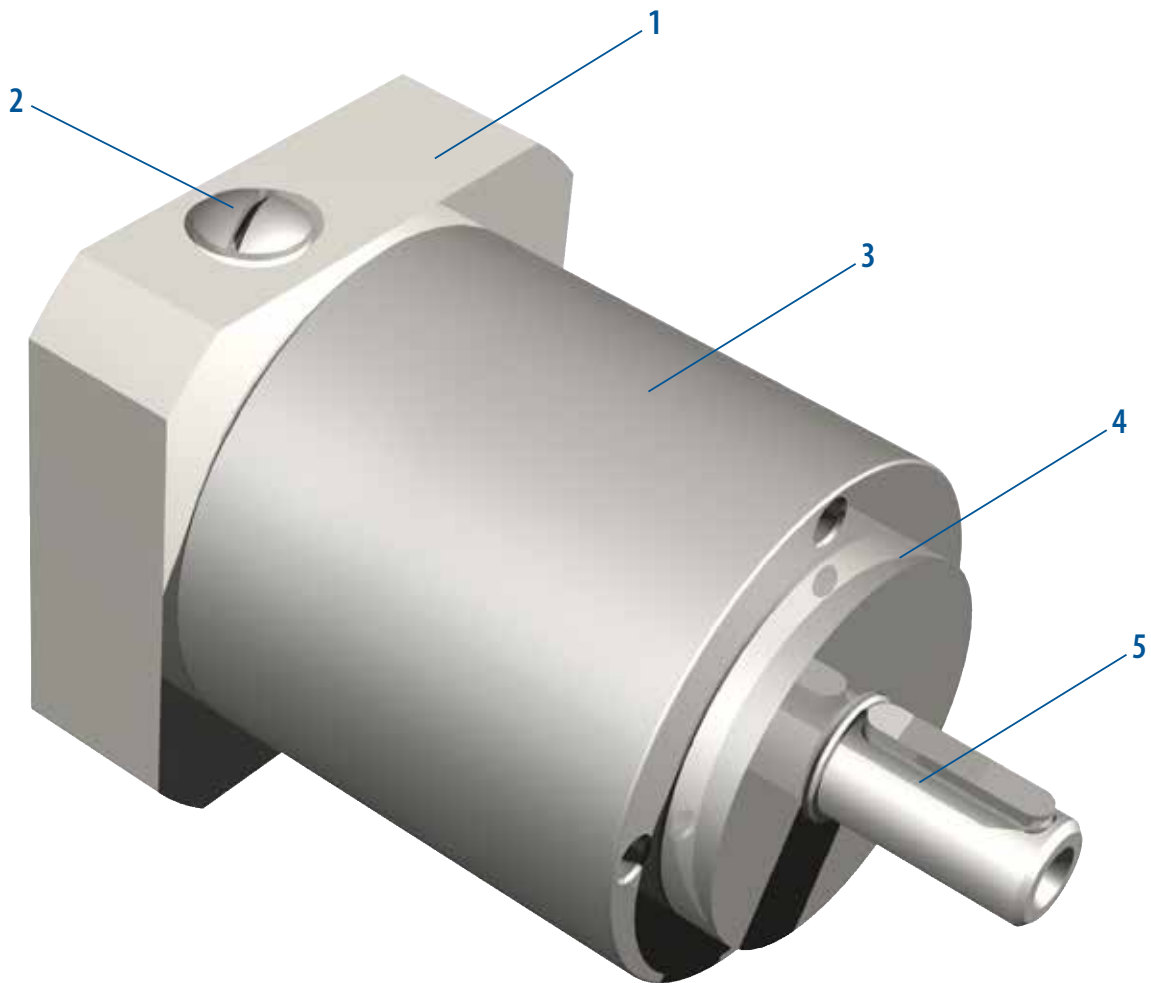

Suitable for food or medical applications!

1. Adapter Flange

(Stainless steel adapter for quick and easy motor mounting)

2. Hole Plug

(Threaded stainless steel plug)

3. Lubrication (internal)

(Standard with food grade grease)

4. Seals (internal)

(Viton® seals keep contaminants out and lubricant in and achieves an IP66 rating)

5. Shaft

(Stainless steel keyed output shaft)

Sold & Serviced By:

 **ELECTROMATE**

Toll Free Phone (877) SERV098

Toll Free Fax (877) SERV099

35 www.electromate.com
sales@electromate.com

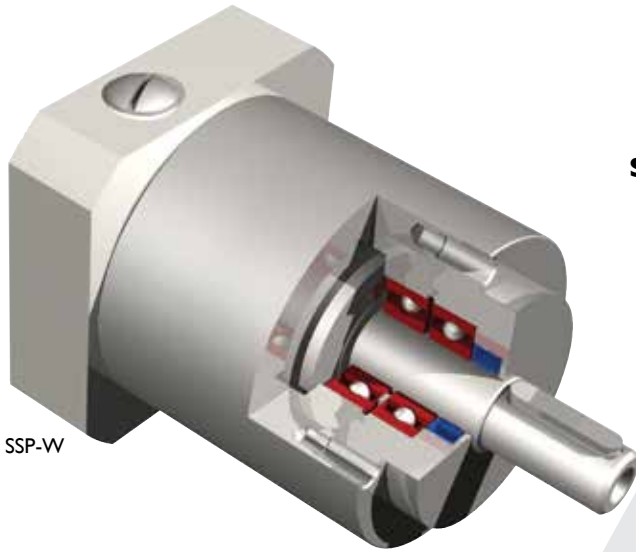

SSP-W

SSP-W

- Dual output bearings for high radial and axial loading
- Frame sizes from 70 mm to 120 mm
- Ratios from 3:1 to 100:1

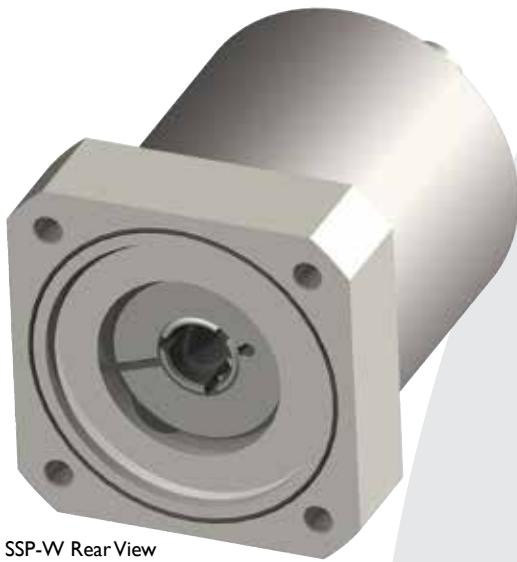

SSP-W Rear View

SSP-W

- Input clamping element for fast and easy mounting
- Optional input O-ring to keep contaminants out custom designed for your motor. (Special request at time of order)



SSP-W with Coupling

SSP-W

- Optional stainless steel output coupling KG-VA for corrosion resistant connections to other shafts
- Contact GAM for more information on these couplings

Sold & Serviced By:

 **ELECTROMATE**

Toll Free Phone (877) SERV098

Toll Free Fax (877) SERV099

www.electromate.com

sales@electromate.com



▶ SSP-SERIES - SSP



SSP Series		70	90	120	
Stock Ratios		5,10			
All Ratios Available		1-stage: 3, 4, 5, 7, 10 2-stage: 12, 16, 20, 25, 35, 40, 50, 70, 100 For other ratios, consult GAM			
Nominal Output Torque (T_{2n})	Nm (lb-in)	3:1	20 (177)	40 (354)	100 (885)
		4, 5, 7:1	26 (230)	54 (478)	120 (1062)
		10, 100, 1000:1	16 (142)	40 (354)	105 (929)
		12:1	36 (319)	80 (708)	170 (1505)
		all other ratios	42 (372)	100 (885)	210 (1859)
Max Acceleration Output Torque (T_{2B})	Nm (lb-in)	3:1	36 (319)	70 (620)	180 (1593)
		4, 5, 7:1	44 (389)	100 (885)	200 (1770)
		10, 100, 1000:1	24 (212)	75 (664)	180 (1593)
		12:1	45 (398)	100 (885)	215 (1903)
		all other ratios	52 (460)	125 (1106)	255 (2257)
Emergency Output Torque (T_{2not})	Nm (lb-in)	3:1	72 (637)	160 (1416)	200 (1770)
		4, 5, 7:1	84 (743)	216 (1912)	480 (4248)
		10, 100, 1000:1	62 (549)	160 (1416)	410 (3629)
		12:1	72 (637)	160 (1416)	400 (3540)
		all other ratios	84 (743)	216 (1912)	480 (4248)
Nominal Input Speed (n_{1n})	RPM	-	3500	3000	2500
Max Speed (n_{1max})		-	6000	6000	5000
Standard Output Backlash (j)	arcmin	3:1 - 10:1	< 10	< 10	< 8
		12:1 - 100:1	< 14	< 14	< 12
Allowable Radial Load (F_{rad}) ¹⁾	N (lbs)	-	910 (205)	1500 (338)	3000 (675)
Allowable Axial Load (F_{axial})	N (lbs)	-	500 (113)	1000 (225)	1500 (338)
Torsional Stiffness (C_{t21})	Nm/arcmin (lb-in/rcmin)	10:1, 100:1	1.3 (11.5)	3.4 (30.1)	8.3 (73.5)
		7:1, 70:1	1.7 (15)	4.8 (42.5)	13.6 (120.4)
		all other ratios	2.4 (21.2)	7.1 (62.8)	17.2 (152.2)
Weight (m)	kg (lbs)	1-stage	2 (4.4)	3.9 (8.6)	8.8 (19.4)
		2-stage	2.3 (5.1)	4.7 (10.4)	10.9 (24)
Noise Level (L_{pk})	dB(A)	-	< 64	< 66	< 68
Mass Moment of Inertia (J_1)	kg cm ² (lb-in ²)	3:1	0.45 (0.154)	1.37 (0.468)	6.54 (2.235)
		4:1, 12:1, 16:1	0.38 (0.130)	1.14 (0.390)	4.8 (1.640)
		5:1, 20:1, 25:1	0.36 (0.123)	1.05 (0.359)	4.05 (1.384)
		7:1, 35:1	0.35 (0.120)	0.97 (0.331)	3.4 (1.162)
		10:1, 40:1 - 100:1	0.34 (0.116)	0.93 (0.318)	3.1 (1.059)
Efficiency at Load		1-stage: 94% 2-stage: 92%			
Service Life		> 30,000 hours			
Lubrication		Food Grade Grease: Note 1. Meets FDA 21 CFR 178.3570 requirements Note 2. USDA H1 authorized (authorized for use in federally inspected meat and poultry plants)			
Protection Rating		IP 66			
Operating Temperature Range		-20°C to 90°C			

Sold & Serviced By: **ELECTROMATE**

Toll Free Phone (877) SERV099

Toll Free Fax (877) SERV099

www.electromate.com

sales@electromate.com

SSP-W

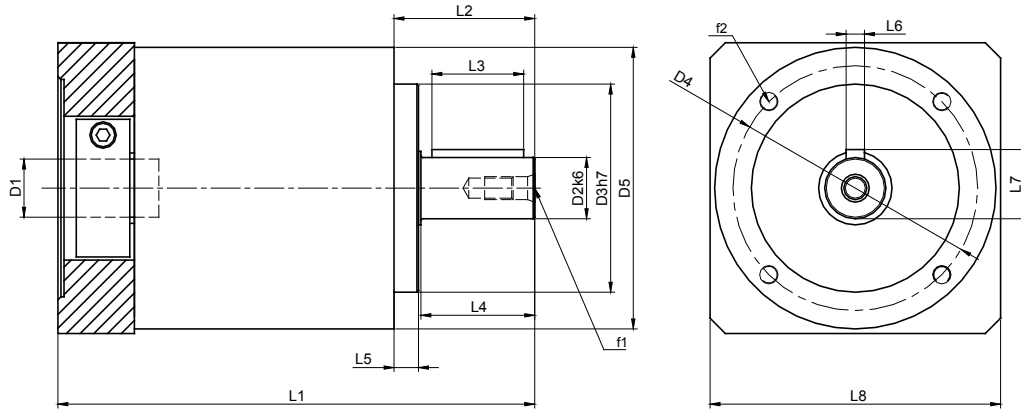

SSP Series		70		90		120	
		mm	(in)	mm	(in)	mm	(in)
D1 max standard	motor shaft diameter	14	(0.551)	19	(0.748)	24	(0.945)
D1 max available*	motor shaft diameter	16	(0.63)	24	(0.945)	32	(1.26)
D2 k6	output shaft diameter	16	(0.63)	22	(0.866)	32	(1.26)
D3 h7	pilot diameter	52	(2.047)	68	(2.677)	90	(3.543)
D4	bolt circle	62	(2.441)	80	(3.15)	108	(4.252)
D5	housing diameter	70	(2.756)	92	(3.622)	122	(4.803)
f1	shaft thread	M5x12		M6x16		M10x22	
f2	mounting holes	M6x12		M6x14		M8x18	
L1 1-STAGE***	gearbox total length	131 (5.157)		174 (6.85)		232 (9.134)	
L1 2-STAGE***		153 (6.024)		207 (8.15)		271 (10.669)	
L2	shaft length	36 (1.417)		46 (1.811)		70 (2.756)	
L3	key length	25 (0.984)		30 (1.181)		50 (1.969)	
L4	usable shaft length	28 (1.102)		36 (1.417)		58 (2.283)	
L5	pilot height	7 (0.276)		9 (0.354)		11 (0.433)	
L6	key width	5 (0.197)		6 (0.236)		8 (0.315)	
L7	key height	18 (0.709)		24.600 (0.969)		34.8 (1.37)	

* for these larger motor shaft diameters, please contact GAM

** depending on the motor, value can vary



Recommended Output Coupling (if necessary)

all stainless bellows	KG-VA-80	KG-VA-220	KG-VA-350
-----------------------	----------	-----------	-----------

TYPE CODES FOR SSP SERIES (SSP-W)

Example: SSP - W - 090 - 005 G - [115 - A01] - S111

Gearbox Series

Stainless Steel
Planetary Series

Gearbox Style

W = Output Shaft

Gearbox Size

070, 090, 120

Ratio

3, 4, 5, 7, 10, 12, 16, 20, 25, 35, 40, 50, 70, 100

Special Options

Assigned by GAM

Motor Mount Kit

Assigned by GAM

Options Available for This Product

G = Key on output DIN688

Tolerances (mm)

Size	k6	h7
Over 10	+0.012	0
Thru 18	+0.001	-0.018
Over 18	+0.015	0
Thru 30	+0.002	-0.021
Over 30	+0.018	0
Thru 50	+0.002	-0.025
Over 50	+0.021	0
Thru 80	+0.002	-0.030
Over 80	+0.025	0
Thru 120	+0.003	-0.035

Sold & Serviced By:



Toll Free Phone (877) SERV098

Toll Free Fax (877) SERV099

www.electromate.com

sales@electromate.com



▶ HIGH PERFORMANCE: FP SERIES

GAM can.

If you don't see exactly what you need, let us know. We can modify the FP Series gearboxes to meet your needs. Page 4 provides a list of commonly requested modifications to give you a feel for our capabilities.

The FP Series is a “shaftless” planetary gearbox that offers advantages in space and performance. The output flange allows machine elements such as pinion gears, pulleys, rotary index tables, and transmission shafting to be easily connected directly to the output. The design also provides high torsional and tilting rigidity that improves machine performance.

Features and Benefits of the FP Series include:

- Compact design
- High tilting rigidity for high overhung loads
- Best in class performance for accuracy due to
 - High torsional stiffness
 - Low backlash
- Lightweight
- Long design life of 20,000 hours
- Lubricated for life
- Ready for motor mounting
- Ratios 3:1 - 91:1
- Frame sizes from 50 mm to 120 mm

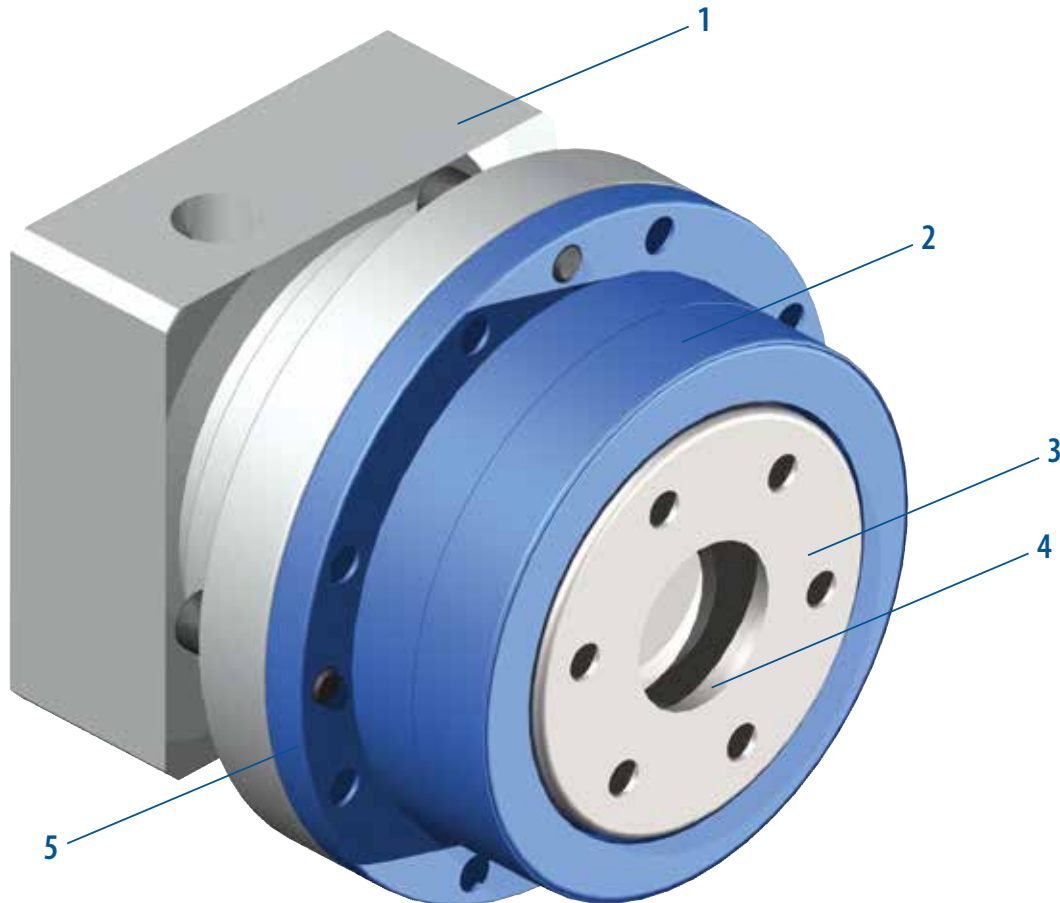

1. Adapter Flange
(Customized adapter flanges for quick and easy motor mounting)

2. Output Bearing (internal)
(Innovative bearing arrangement for high stiffness)

3. Output Flange
(Easily mount components directly to flange)

4. Flange Pilot
(Centering pilot for machine elements)

5. Mounting Flange
(Allows for compact machine mounting)

Sold & Serviced By:



Toll Free Phone (877) SERV099
Toll Free Fax (877) SERV099

39 www.electromate.com
sales@electromate.com

▶ HIGH PERFORMANCE: FP SERIES



FP-FB
Bellows output

FP-FB

- Integrated coupling on output for high torsional stiffness and a zero backlash connection while compensating for misalignment
- Available with flange mounted bellows or elastomer couplings

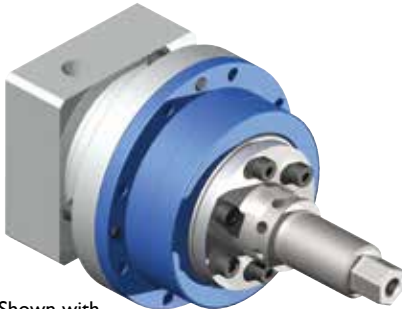

Shown with custom shaft easily bolted to gearbox.

- Simplify machine system – GAM can provide custom shafts with standard FP gearboxes
- Shafts can be easily added and removed with a few bolts when changes are required



Shown with pinion gear bolted to the output face.

- A true zero backlash connection of the pinion to the gearbox.
- Ideal for compact, rigid systems

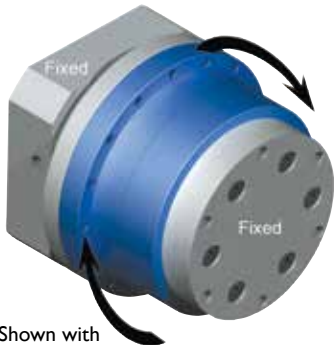

Shown with output face fastened to stationary element. Gearbox housing will rotate.

FP-P

- Fixing output will allow rotation of housing
- A compact solution for space constraints



- Eliminate unnecessary components by fastening machine elements to the gearbox
- Gearbox housing rotates to directly drive a wheel or pulley

Sold & Serviced By:

 **ELECTROMATE**

Toll Free Phone (877) SERV098

Toll Free Fax (877) SERV099

www.electromate.com

sales@electromate.com



▶ FP SERIES - FP



FP-F/P Series*			50		70		90		120	
Stock Ratios*			5, 10							
All Ratios Available*			4, 5, 7, 10, 16, 20, 21, 25, 28, 31, 35, 43, 49, 61, 91 (91:1 ratio not available in size 50)							
Nominal Output Torque (T _{2n})	Nm (lb-in)	4:1, 5:1, 7:1	6.5	(58)	26	(230)	54	(478)	120	(1062)
		10:1, 91:1	5	(44)	16	(142)	40	(354)	105	(929)
		all other ratios	16	(142)	44	(389)	100	(885)	210	(1859)
Max Acceleration Output Torque (T _{2B})	Nm (lb-in)	4:1, 5:1, 7:1	13	(115)	36	(319)	100	(885)	200	(1770)
		10:1, 91:1	9	(80)	24	(212)	75	(664)	180	(1593)
		all other ratios	18	(159)	55	(487)	125	(1106)	255	(2257)
Emergency Output Torque (T _{2not})	Nm (lb-in)	4:1, 5:1, 7:1	26	(230)	84	(743)	216	(1912)	480	(4248)
		10:1, 91:1	20	(177)	62	(549)	110	(974)	410	(3629)
		all other ratios	26	(230)	84	(743)	216	(1912)	480	(4248)
Nominal Speed (n _{1n})	RPM	-	3000		3000		3000		2500	
Max Speed (n _{1max})		-	6000		6000		5000		5000	
Standard Output Backlash (j)	arcmin	1 Stage	<12		<8		<8		<8	
		2 Stage	<15		<11		<11		<11	
Reduced Output Backlash (j)	arcmin	1 Stage	<8		<5		<5		<5	
		2 Stage	<12		<8		<8		<8	
Radial Load (F _{rad})	N (lbs)	100rpm	1333	(300)	1932	(434)	3972	(893)	6541	(1470)
		200rpm	1131	(254)	1389	(312)	2540	(571)	3955	(889)
		300rpm	848	(191)	1050	(236)	1837	(413)	2696	(606)
Axial Load (F _{axial})	N (lbs)	100rpm	359	(81)	445	(100)	795	(179)	1175	(264)
		200rpm	243	(55)	293	(66)	508	(114)	709	(159)
		300rpm	186	(42)	219	(49)	368	(83)	483	(109)
Tilting Rigidity ¹	Nm/arcmin (lb-in/arcmin)	-	11	(97)	19	(168)	51	(451)	127	(1124)
Tilting Moment Load (M _T)**	Nm (lb-in)	100rpm	33	(292)	57	(505)	147	(1301)	296	(2620)
		200rpm	28	(248)	41	(363)	94	(832)	179	(1584)
		300rpm	21	(186)	31	(274)	68	(602)	122	(1080)
Torsional Stiffness	Nm/arcmin (lb-in/arcmin)	4, 16, 20, 28	0.5	(4.4)	2.4	(21.12)	7.1	(62.48)	17.2	(151.36)
		5, 21, 25, 35	0.5	(4.4)	2.4	(21.12)	7.1	(62.48)	17.2	(151.36)
		7, 31, 43, 49, 61	0.4	(3.52)	2.2	(19.36)	6	(52.8)	14	(123.2)
		10, 91	0.4	(3.52)	2	(17.6)	5	(44)	10	(88)
Weight (m)	kg (lbs)	1 Stage	0.8	(2)	1.5	(3)	3.5	(8)	7.6	(17)
		2 Stage	1	(2.2)	1.8	(4)	3.8	(8.4)	8.4	(18.5)
Noise Level (L _{pa})	dB	-	< 64		< 66		< 68		< 70	
Mass Moment of Inertia (J ₁)	kg cm ²	all ratios	1 Stage	2 Stage	1 Stage	2 Stage	1 Stage	2 Stage	1 Stage	2 Stage
			0.06	0.06	0.32	0.06	1.4	0.31	2.97	1.36
Efficiency at Load	1 stage efficiency: 94% 2 stage efficiency: 92%									
Service Life	>20,000 hours									
Lubrication	Lifetime lubricant with grease									
Protection Rating	IP 65									
Operating Temperature Range	-10°C to 90°C									

* Ratio for FP-P are (n-1) **Maximum value without axial load
1) Radial load distance shown in dimension tables (L7)

Sold & Serviced By:
ELECTROMATE
 Toll Free Phone (877) SERV098
 Toll Free Fax (877) SERV099
www.electromate.com
sales@electromate.com

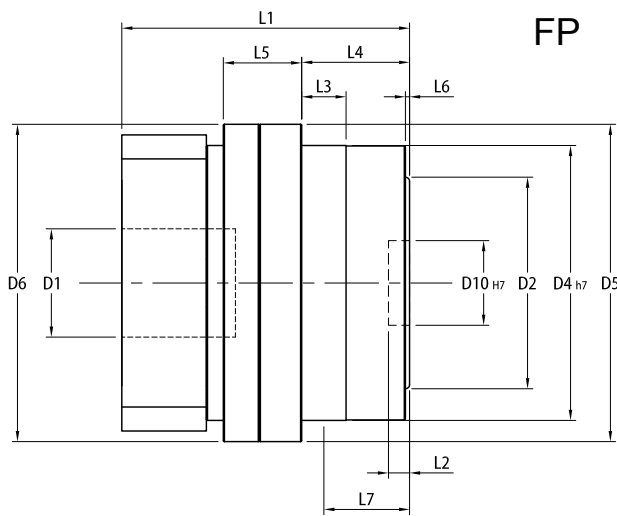

FP

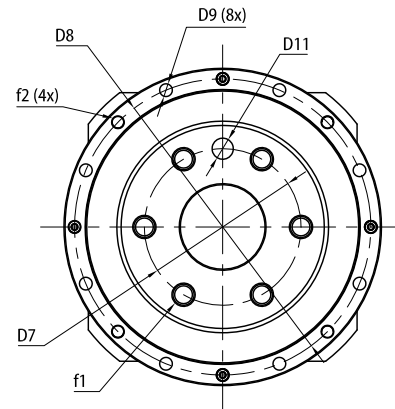

FP Series		50		70		90		120	
		mm	(in)	mm	(in)	mm	(in)	mm	(in)
D1 _{max}	motor shaft diameter	14	(0.551)	14	(0.551)	22	(0.866)	28	(1.102)
D1 _{max} (2-Stage)	motor shaft diameter	14	(0.551)	14	(0.551)	19	(0.748)	22	(0.866)
D2	output flange diameter	42	(1.654)	55	(2.165)	75	(2.953)	105	(4.134)
D4 h7	pilot diameter	57	(2.244)	72	(2.835)	100	(3.937)	130	(5.118)
D5	flange diameter	69	(2.717)	84	(3.307)	118	(4.646)	150	(5.906)
D6	input housing diameter	56	(2.205)	72	(2.835)	100	(3.937)	130	(5.118)
D7	inner bolt circle	28	(1.102)	36	(1.417)	60	(2.362)	80	(3.150)
D8	outer bolt circle	63	(2.480)	78	(3.071)	109	(4.291)	140	(5.512)
D9	mounting holes	3.5	(0.138)	3.5	(0.138)	4.5	(0.177)	5.5	(0.217)
D10 H7	flange pilot	12	(0.472)	19	(0.748)	28	(1.102)	40	(1.575)
D11	dowel diameter x depth	4 x 4		5x5		6x6		8x8	
f1	flange through holes	6 x M4		6 x M5		6 x M6		6 x M8	
f2	threaded mounting holes	M3		M3		M4		M5	
L1** (1-Stage)	gearbox total length	69	(2.717)	83	(3.268)	107	(4.213)	134	(5.276)
L1** (2-Stage)	gearbox total length	100	(3.937)	95	(3.740)	120	(4.724)	147	(5.787)
L2	flange pilot depth	5	(0.197)	5	(0.197)	8	(0.315)	7	(0.276)
L3	pilot height	12	(0.472)	12	(0.472)	17	(0.669)	21	(0.827)
L4	output length	29	(1.142)	33	(1.299)	40.5	(1.594)	52.5	(2.067)
L5	flange length	15.5	(0.610)	20	(0.787)	28	(1.102)	37	(1.457)
L6	output flange height	3	(0.118)	3	(0.118)	3.5	(0.138)	3.5	(0.138)
L7	radial load distance	24.75	(0.974)	29.5	(1.161)	37	(1.457)	45.25	(1.781)

* for larger motor shaft diameters, please contact GAM ** depending on the motor, value can vary

TYPE CODES FOR FP SERIES (FP)

Example: FP - F - 070 - 005H - [115 - A01] - S111

Gearbox Series

FP = Flange Planetary

Gearbox Style

F = Output Flange Rotates

P = Gearbox Housing Rotates

FB = Bellows Coupling Output

Gearbox Size

050, 070, 090, 120

Ratio

4, 5, 7, 10, 16, 20, 21, 25, 28, 31, 35, 43, 49, 61, 91

(91:1 not available for size 50)

Ratio for FP-P is (n-1)

Special Options

Assigned by GAM

Motor Mount Kit

Assigned by GAM

Options Available for This Product

H = standard backlash

A = reduced backlash

Tolerances (mm)		
Size	h7	H7
Over 10	0	+0.018
Thru 18	-0.018	0
Over 18	0	+0.021
Thru 30	-0.021	0
Over 30	0	+0.025
Thru 50	-0.025	0
Over 50	0	+0.030
Thru 80	-0.030	0
Over 80	0	+0.035
Thru 120	-0.035	0
Over 120	0	+0.040
Thru 180	-0.040	0

Sold & Serviced By:



Toll Free Phone (877) SERV098

Toll Free Fax (877) SERV099

www.electromate.com

sales@electromate.com



▶ PERFORMANCE: PE SERIES

GAM can.

If you don't see exactly what you need, let us know. We can modify the PE Series gearboxes to meet your needs. Page 4 provides a list of commonly requested modifications to give you a feel for our capabilities.

The GAM PE series is a great gearbox value for servo, stepper, and other motion control applications. It offers the best quality available for the price point. Based on the design of the popular EPL series, the PE series is a reliable alternative when radial or axial loadings are minimized.

PE Series offers:

- Metric output (4 sizes)
- NEMA output (4 sizes)
- Wide range of ratios (3:1 to 1000:1)
- Available to purchase online!
- Improved backlash specifications
- Increased service life

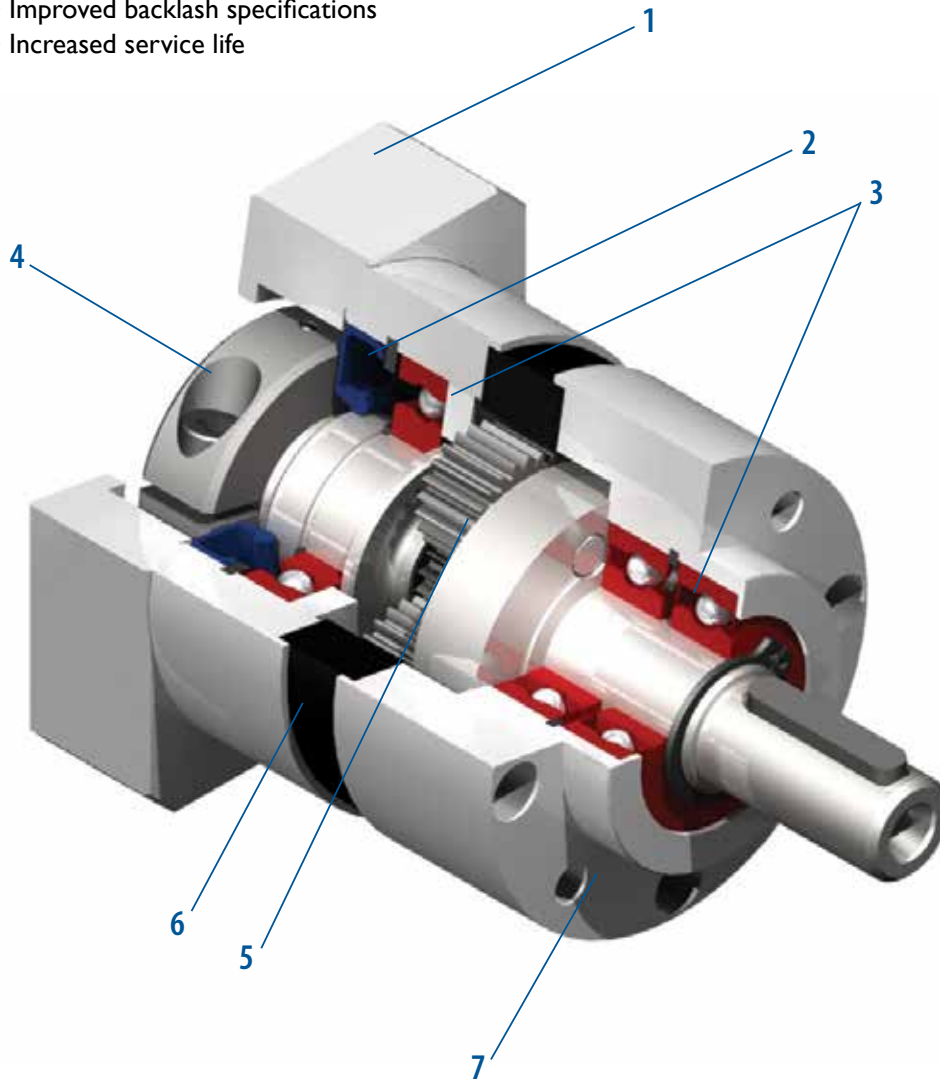

- | | |
|---|---|
| 1. Adapter Plate
(Customized adapter plates for quick and easy motor mounting) | 4. Input Clamping Element |
| 2. Seals
(Protective seals to isolate the gearbox) | 5. Planet Gears
(Precision honed gears) |
| 3. Ball Bearings
(dual ball bearings) | 6. Ring Gear
(Ring gear incorporated into housing) |
| | 7. Output Face |

Sold & Serviced By:



Toll Free Phone (877) SERV098
Toll Free Fax (877) SERV099
www.electromate.com
sales@electromate.com

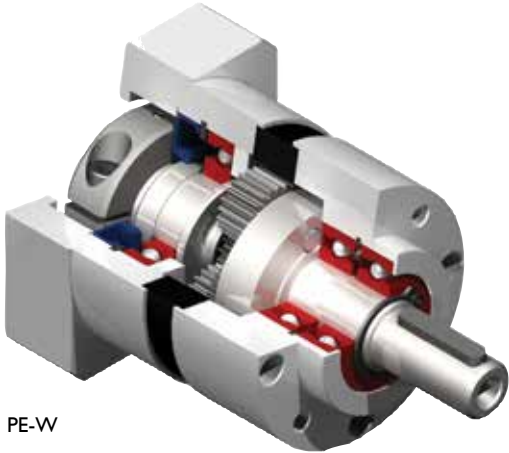

PE-W

PE-W

- Metric output face
- Ratios 3:1 to 1000:1
- Frame sizes from 50 mm to 118 mm
- Ready to mount to your motor

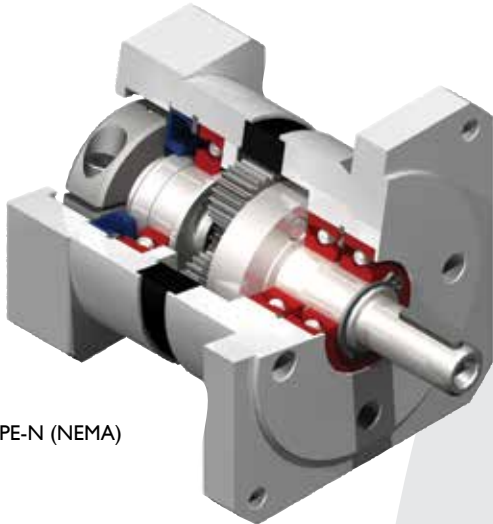

PE-N (NEMA)

PE-N (NEMA)

- NEMA output face
- Ratios 3:1 to 1000:1
- Frame sizes from NEMA 17 to 42
- Ready to mount to your motor

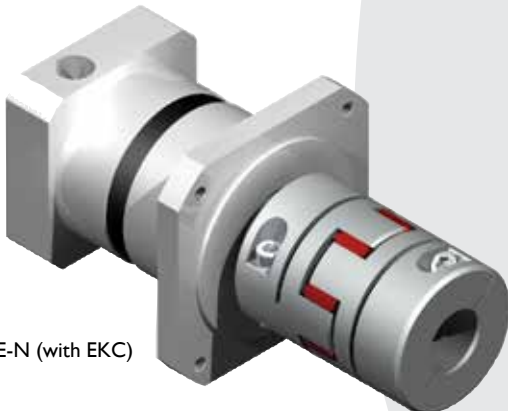

PE-N (with EKC)

PE-N (shown with GAM's EKC elastomer coupling)

- Use the PE Series gearbox with the EKC coupling for the most cost-effective solution!

Sold & Serviced By:

 **ELECTROMATE**

Toll Free Phone (877) SERV098

Toll Free Fax (877) SERV099

www.electromate.com

sales@electromate.com



▶ PE-W SERIES - (METRIC)

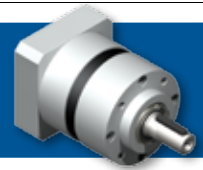

PE-W Series		50	64	84	118	
Stock Ratios		5, 10, 50				
All Ratios Available		1-stage: 3, 4, 5, 7, 10 2-stage: 12, 16, 20, 25, 35, 40, 50, 70, 100 3-stage: 120, 160, 200, 250, 350, 490, 700, 1000				
Nominal Output Torque (T_{2n})	Nm (lb-in)	3:1	5 (44)	20 (177)	40 (354)	100 (885)
		4, 5, 7:1	6.5 (58)	26 (230)	54 (478)	120 (1062)
		10, 100, 1000:1	5 (44)	16 (142)	40 (354)	105 (929)
		12:1	14 (124)	36 (319)	80 (708)	170 (1505)
		all other ratios	16 (142)	42 (372)	100 (885)	210 (1859)
Max Acceleration Output Torque (T_{2B})	Nm (lb-in)	3:1	10 (89)	36 (319)	70 (620)	180 (1593)
		4, 5, 7:1	13 (115)	44 (389)	100 (885)	200 (1770)
		10, 100, 1000:1	10 (89)	24 (212)	75 (664)	180 (1593)
		12:1	17.5 (155)	45 (398)	100 (885)	215 (1903)
		all other ratios	20 (177)	52 (460)	125 (1106)	255 (2257)
Emergency Output Torque (T_{2not})	Nm (lb-in)	3:1	20 (177)	72 (637)	160 (1416)	200 (1770)
		4, 5, 7:1	26 (230)	84 (743)	216 (1912)	480 (4248)
		10, 100, 1000:1	20 (177)	62 (549)	160 (1416)	410 (3629)
		12:1	28 (248)	72 (637)	160 (1416)	400 (3540)
		all other ratios	32 (283)	84 (743)	216 (1912)	480 (4248)
Nominal Speed (n_{1n})	RPM	-	3500	3500	3000	2500
Max Speed (n_{1max})		-	6000	6000	6000	5000
Standard Output Backlash (j)	arcmin	3:1 - 10:1	<16	<10	<10	<8
		12:1 - 100:1	<20	<14	<14	<12
		120:1 - 1000:1	-	<18	<18	<16
Allowable Radial Load (F_{rad}) ¹⁾	N (lbs)	-	425 (96)	560 (126)	1300 (293)	2500 (563)
Allowable Axial Load (F_{axial})	N (lbs)	-	350 (79)	500 (113)	1000 (225)	1500 (338)
Torsional Stiffness (C_{t21})	Nm/arcmin (lb-in/arcmin)	10, 100, 1000	0.60 (5.3)	1.3 (11.5)	3.4 (30.1)	8.3 (73.5)
		7, 70, 700	0.78 (6.9)	1.7 (15)	4.8 (42.5)	13.6 (120.4)
		all other ratios	0.9 (8.0)	2.4 (21.2)	7.1 (62.8)	17.2 (152.2)
Weight (m)	kg (lbs)	1-stage	0.4 (0.9)	1.0 (2.2)	2.3 (5.1)	5.8 (12.8)
		2-stage	0.5 (1.1)	1.3 (2.9)	3.1 (6.8)	7.9 (17.4)
		3-stage	- (-)	1.6 (3.5)	3.9 (8.6)	10.0 (22.1)
Noise Level (L_{pA})	dB(A)	-	< 64	< 66	< 68	< 70
Mass Moment of Inertia (J_1)	kg cm ² (lb-in ²) (lb-in ²)	3:1	0.06 (0.021)	0.45 (0.154)	1.37 (0.468)	6.54 (2.235)
		4:1, 12:1, 16:1	0.04 (0.014)	0.38 (0.130)	1.14 (0.390)	4.8 (1.640)
		5:1, 20:1, 25:1	0.04 (0.014)	0.36 (0.123)	1.05 (0.359)	4.05 (1.384)
		7:1, 35:1	0.04 (0.014)	0.35 (0.120)	0.97 (0.331)	3.4 (1.162)
		10:1, 40:1 - 100:1	0.04 (0.014)	0.34 (0.116)	0.93 (0.318)	3.1 (1.059)
		120:1 - 1000:1	(0.000)	0.34 (0.116)	0.93 (0.318)	3.12 (1.066)
Efficiency at Load	1-stage: 94% 2-stage: 92% 3-stage: 90%					
Service Life	>20,000					
Lubrication	Mineral Grease EP0					
Protection Rating	IP 64					
Operating Temperature Range	-20°C to 90°C					

1) Load applied at center of output shaft @100 RPM

Sold & Serviced By:
ELECTROMATE
 Toll Free Phone (877) SERV098
 Toll Free Fax (877) SERV099
www.electromate.com
sales@electromate.com

PE-W

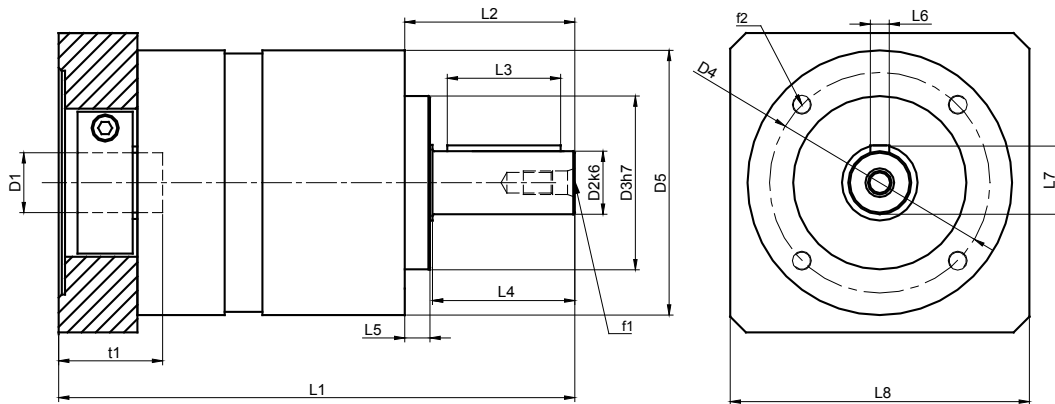

mm (in)		50	64	84	118
D1 _{max standard*}	motor shaft diameter	11 (0.433)	14 (0.551)	19 (0.748)	24 (0.945)
D1 _{max available*}	motor shaft diameter	14 (0.551)	16 (0.630)	24 (0.945)	32 (1.260)
D2 _{k6}	output shaft diameter	12 (0.472)	14 (0.551)	20 (0.787)	25 (0.984)
D3 _{h7}	pilot diameter	35 (1.378)	40 (1.575)	55 (2.165)	80 (3.15)
D4	bolt circle	44 (1.732)	52 (2.047)	70 (2.756)	100 (3.937)
D5	housing diameter	50 (1.969)	64 (2.52)	84 (3.307)	118 (4.646)
f1	shaft thread	M4x8	M5x12	M6x16	M10x22
f2	mounting holes	M4x6	M5x12	M6x14	M8x18
L1 1-STAGE**	gearbox total length	93 (3.661)	117 (4.606)	162 (6.378)	199 (7.835)
L1 2-STAGE**		108 (4.252)	139 (5.472)	195 (7.677)	239 (9.409)
L1 3-STAGE**		- (-)	161 (6.339)	228 (8.976)	280 (11.024)
L2	shaft length	24.5 (0.965)	39 (1.535)	54 (2.126)	61 (2.402)
L3	key length	16 (0.63)	25 (0.984)	36 (1.417)	45 (1.772)
L4	usable shaft length	18 (0.709)	30 (1.181)	45 (1.772)	50 (1.969)
L5	pilot height	4 (0.157)	8 (0.315)	8 (0.315)	10 (0.394)
L6	key width	4 (0.157)	5 (0.197)	6 (0.236)	8 (0.315)
L7	key height	13.5 (0.531)	16 (0.63)	22.5 (0.886)	28 (1.102)
L8**	adapter size	50 (1.969)	70 (2.756)	90 (3.543)	120 (4.724)
t1***	allowable shaft length	23 (0.87)	23 (0.906)	30 (1.181)	40 (1.575)

* for larger motor shaft diameters, please contact GAM ** depending on the motor, value can vary *** long motor shafts can be accommodated, but overall gearbox length will grow
 ****The PE-W-050 may have a blue ring gear

	Recommended Output Coupling (if necessary)			
	metal bellows	KLC-25	KLC-50	KLC-125
elastomer	EKC-25	EKC-35	EKC-80 or 110	EKM-300

TYPE CODES FOR PE-W SERIES (METRIC)

Example: PE - W - 084 - 005 G - [115 - A01] - S111

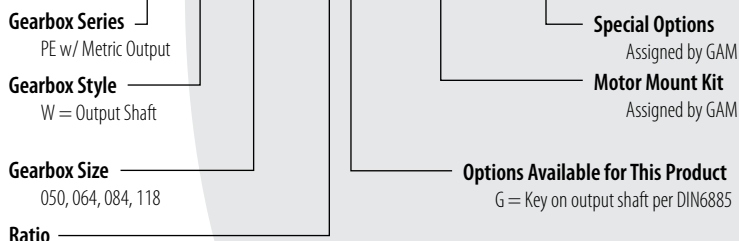

Tolerances (mm)		
Size	k6	h7
Over 6	+0.010	0
Thru 10	+0.001	-0.015
Over 10	+0.012	0
Thru 18	+0.001	-0.018
Over 18	+0.015	0
Thru 30	+0.002	-0.021
Over 30	+0.018	0
Thru 50	+0.002	-0.025
Over 50	+0.021	0
Thru 80	+0.002	-0.030

Sold & Serviced By:

ELECTROMATE

Toll Free Phone (877) SERV098

Toll Free Fax (877) SERV099

www.electromate.com

sales@electromate.com



▶ PE-N SERIES - (NEMA)



PE-N Series		17	23	34	42	
Stock Ratios		5, 10, 50				
All Ratios Available		1-stage: 3, 4, 5, 7, 10 2-stage: 12, 16, 20, 25, 35, 40, 50, 70, 100 3-stage: 120, 160, 200, 250, 350, 490, 700, 1000				
Nominal Output Torque (T _{2n})	Nm (lb-in)	3:1	5 (44)	5 (44)	20 (177)	40 (354)
		4, 5, 7:1	6.5 (58)	6.5 (58)	26 (230)	54 (478)
		10, 100, 1000:1	5 (44)	5 (44)	16 (142)	40 (354)
		12:1	14 (124)	14 (124)	36 (319)	80 (708)
		all other ratios	16 (142)	16 (142)	42 (372)	100 (885)
Max Accel. Torque (T _{2B})	Nm (lb-in)	3:1	10 (89)	10 (89)	36 (319)	70 (620)
		4, 5, 7:1	13 (115)	13 (115)	44 (389)	100 (885)
		10, 100, 1000:1	10 (89)	10 (89)	24 (212)	75 (664)
		12:1	17.5 (155)	17.5 (155)	45 (398)	100 (885)
		all other ratios	20 (177)	20 (177)	52 (460)	125 (1106)
Emergency Output Torque (T _{2not})	Nm (lb-in)	3:1	20 (177)	20 (177)	72 (637)	160 (1416)
		4, 5, 7:1	26 (230)	26 (230)	84 (743)	216 (1912)
		10, 100, 1000:1	20 (177)	20 (177)	62 (549)	160 (1416)
		12:1	28 (248)	28 (248)	72 (637)	160 (1416)
		all other ratios	32 (283)	32 (283)	84 (743)	216 (1912)
Nominal Speed (n _{1n})	RPM	-	3500	3500	3500	3000
Max Input Speed (n _{1max})		-	6000	6000	6000	6000
Standard Output Backlash (j)	arcmin	3:1 - 10:1	<20	<16	< 10	< 10
		12:1 - 100:1	<24	<20	< 14	< 14
		120:1 - 1000:1	-	-	< 18	< 18
Allowable Radial Load (F _{rad}) ¹⁾	N (lbs)	-	361 (81)	361 (81)	476 (107)	1105 (249)
Allowable Axial Load (F _{axial})	N (lbs)	-	298 (67)	298 (67)	425 (96)	850 (191)
Torsional Stiffness (C _{t21})	Nm/arcmin (lb-in/arc-min)	10, 100, 1000	0.50 (4.4)	0.60 (5.3)	1.3 (11.5)	3.4 (30.1)
		7, 70, 700	0.65 (5.8)	0.78 (6.9)	1.7 (15)	4.8 (42.5)
		all other ratios	0.8 (7.5)	0.9 (8.0)	2.4 (21.2)	7.1 (62.8)
Weight (m)	kg (lbs)	1-stage	0.45 (1.0)	0.45 (1.0)	1.1 (2.4)	2.4 (5.3)
		2-stage	0.55 (1.2)	0.55 (1.2)	1.4 (3.1)	3.2 (7.1)
		3-stage	- (-)	- (-)	1.7 (3.7)	4.0 (8.8)
Noise Level (L _{PA})	dB(A)	-	<60	<64	< 66	< 68
Mass Moment of Inertia (J ₁)	kg cm ² (lb-in ²)	3:1	0.0144 (0.005)	0.06 (0.021)	0.45 (0.154)	1.37 (0.468)
		4:1, 12:1, 16:1	0.0096 (0.003)	0.04 (0.014)	0.38 (0.130)	1.14 (0.390)
		5:1, 20:1, 25:1	0.0096 (0.003)	0.04 (0.014)	0.36 (0.123)	1.05 (0.359)
		7:1, 35:1	0.0152 (0.005)	0.04 (0.014)	0.35 (0.120)	0.97 (0.331)
		10:1, 40:1 - 100:1	0.0078 (0.003)	0.04 (0.014)	0.34 (0.116)	0.93 (0.318)
120:1 - 1000:1	- (-)	- (-)	0.34 (0.116)	0.93 (0.318)		
Efficiency at Load	1-stage: 94% 2-stage: 92% 3-stage: 90%					
Service Life	>20,000					
Lubrication	Mineral Grease EPO					
Sold & Serviced By: Protection Rating	IP 64					
Operating Temperature Range	-20°C to 90°C					

¹⁾ Load applied at center of output shaft @100 RPM

PE-N

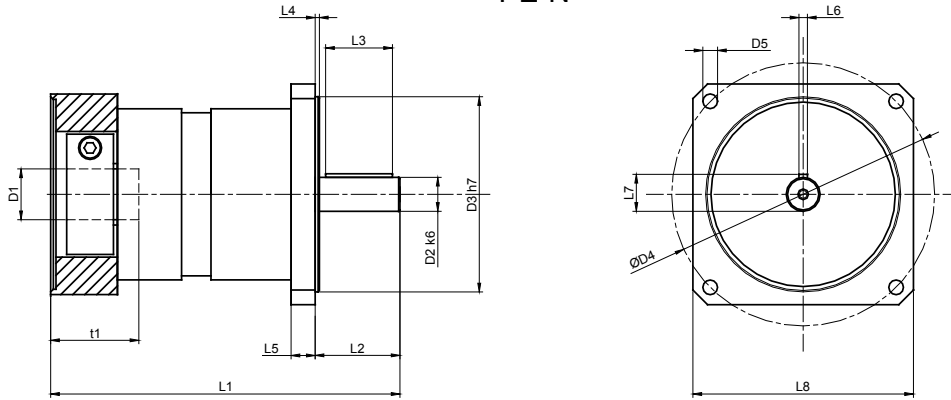

PE-N Series		17		23		34		42	
		mm	(in)	mm	(in)	mm	(in)	mm	(in)
D1 ^{max standard*}	motor shaft diameter	11	(0.433)	11	(0.433)	14	(0.551)	19	(0.748)
D1 ^{max available*}	motor shaft diameter	11	(0.433)	14	(0.551)	16	(0.630)	24	(0.945)
D2 ^{k6}	output shaft diameter	9.525	(0.375)	9.525	(0.375)	12.700	(0.500)	19.05	(0.750)
D3 ^{h7}	pilot diameter	21.97	(0.865)	38.100	(1.500)	73.025	(2.875)	55.55	(2.187)
D4	bolt circle	43.8	(1.725)	66.7	(2.625)	98.400	(3.875)	125.7	(4.95)
D5	mounting holes	3.25	(0.128)	5	(0.2)	5.5	(0.22)	7.1	(0.28)
L1 1-STAGE**	gearbox total length	108	(4.252)	102	(4.016)	125	(4.921)	162	(6.378)
L1 2-STAGE**		124	(4.882)	122.5	(4.823)	147	(5.787)	194.5	(7.657)
L1 3-STAGE**		-	(-)	-	(-)	169	(6.654)	227	(8.937)
L2	shaft length	25.4	(1.00)	25.4	(1.00)	31.8	(1.25)	31.8	(1.25)
L3	key length	-	(-)	-	(-)	27	(1.06)	29	(1.14)
L4	pilot height	1.6	(0.063)	1.6	(0.06)	1.7	(0.07)	2.4	(0.09)
L5	flange thickness	4.9	(0.193)	5	(0.2)	10	(0.39)	13	(0.51)
L6	key width	-	(-)	-	(-)	3.2	(0.13)	4.8	(0.19)
L7	key height / flat height	9.14	(0.36)	9.14	(0.36)	14.3	(0.56)	18.260	(0.72)
L8	output flange size	40	(1.575)	57.14	(2.25)	82.55	(3.25)	106.68	(4.20)
t1***	allowable motor shaft	25	(0.984)	23	(0.87)	32	(1.26)	40	(1.575)

* for larger motor shaft diameters, please contact GAM **depending on the motor, value can vary *** longer motor shafts can be accommodated, but overall gearbox length will grow



Recommended Output Coupling (if necessary)

	17	23	34	42
metal bellows	KLC-25	KLC-25	KLC-50	KLC-125
elastomer	EKC-25	EKC-25	EKC-80	EKC-110

TYPE CODES FOR PE-N SERIES (NEMA)

Example: PE - N23 - 005 G - [115 - A01] - S111

Gearbox Series
NPE w/ NEMA output

Gearbox Style

N17 = NEMA17
N23 = NEMA23
N34 = NEMA34
N42 = NEMA42

Ratio

3, 4, 5, 7, 10, 12, 16, 20, 25, 35, 40, 50, 70, 100,
200, 160, 200, 250, 350, 490, 700, 000=1000

Special Options

Assigned by GAM

Motor Mount Kit

Assigned by GAM

Options Available for This Product

G = Key on output shaft per DIN6885
flat on NEMA 17 and NEMA 23

Tolerances (mm)

Size	k6	h7
Over 6	+0.010	0
Thru 10	+0.001	-0.015
Over 10	+0.012	0
Thru 18	+0.001	-0.018
Over 18	+0.015	0
Thru 30	+0.002	-0.021
Over 30	+0.018	0
Thru 50	+0.002	-0.025
Over 50	+0.021	0
Thru 80	+0.002	-0.030

Sold & Serviced By:

ELECTROMATE

Toll Free Phone (877) SERV098

Toll Free Fax (877) SERV099

www.electromate.com

sales@electromate.com



▶ HIGHEST PERFORMANCE: DYNA SERIES

GAM can.

If you don't see exactly what you need, let us know. We can modify the Dyna Series gearboxes to meet your needs. Page 4 provides a list of commonly requested modifications to give you a feel for our capabilities.

The Dyna Series is our highest performance right-angle gear reducer utilizing sophisticated hypoid gearing. The benefit of hypoid gearing is that it combines the space and configuration advantages of worm gearing with the high efficiencies of bevel gearing. The result is that the Dyna Series is able to achieve ratios up to 15:1 in a single stage and ratios up to 100:1 in 2 stages.

⚠ **DSX version for the highest performance available!**

The DSX is our flagship right angle hypoid gearbox that has been optimized for the most demanding motion control applications that require high angular accuracy. Featuring hypoid gears that have been ground, the DSX has the smoothest torque transmission and extremely low backlash and noise levels.

Contact GAM for further information on the DSX.

Dyna Series benefits include:

- Ratios up to 15:1 in a single stage – the highest in the market – and 100:1 in just two gear stages
- High efficiencies
- High allowable axial and radial loading
- Ultra low backlash
- Back drivable
- Multiple output shaft configurations and hollow output

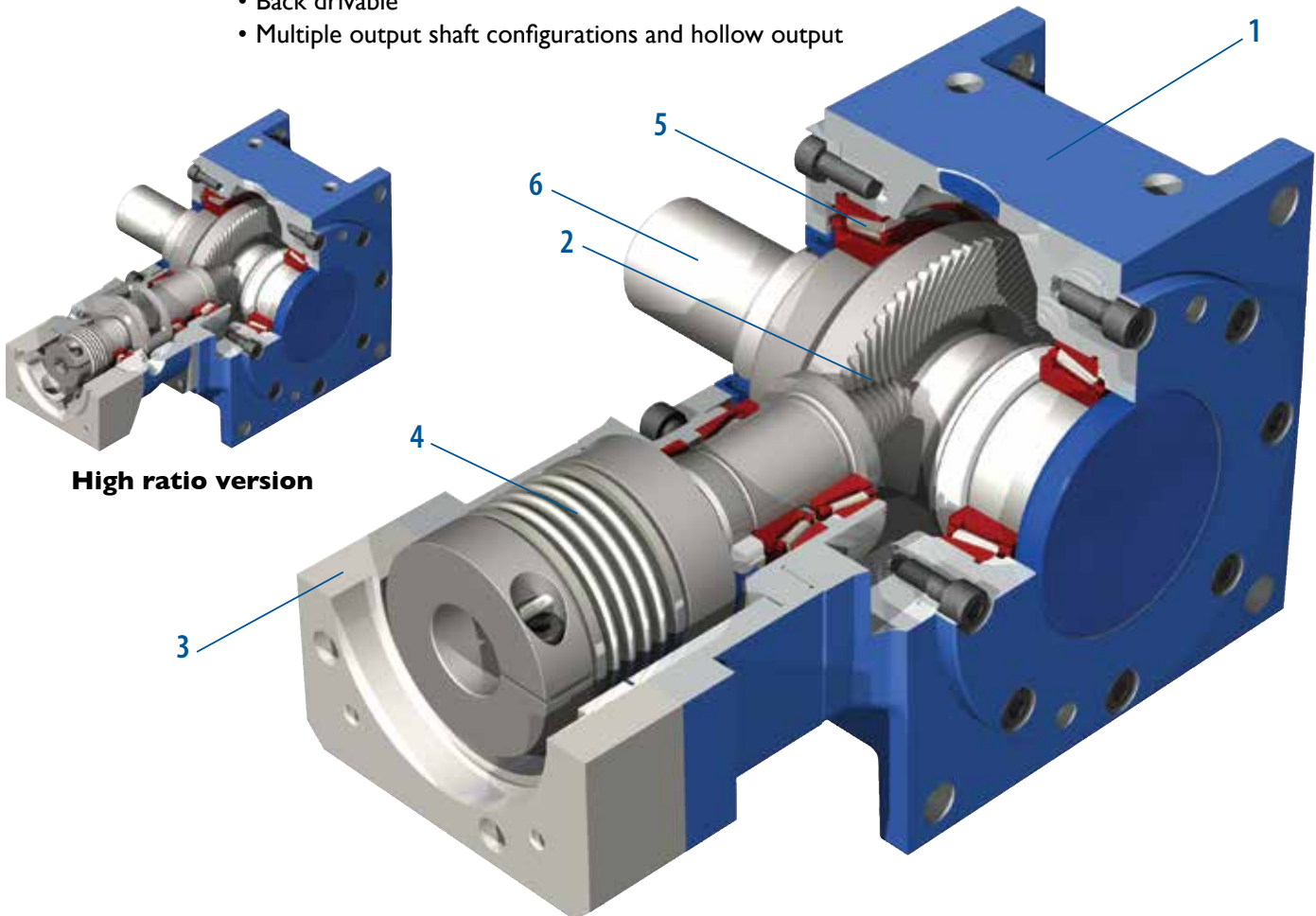

High ratio version

- | | | |
|---|---|---|
| <p>1. Aluminum Housing
(Aluminum housing significantly reduces the weight of the gearbox)</p> | <p>3. Adapter Flange
(Customized adapter flanges for quick and easy mounting to any motor)</p> | <p>5. Tapered Roller Bearings
(Roller bearings for high radial and axial loading)</p> |
| <p>2. Hypoid Gearing
(Optimized gearing allows ratios up to 15:1 in a single stage; 100:1 in two stages. DSX gears are ground for improved performance.)</p> | <p>4. Coupling
(Gearbox can be supplied with either a bellows or elastomer coupling)</p> | <p>6. Output Shaft
(Gearbox can be supplied with one or two solid shafts or hollow shafts)</p> |

Sold & Serviced By:



Toll Free Phone (877) SERV099
Toll Free Fax (877) SERV099

49 www.electromate.com
sales@electromate.com

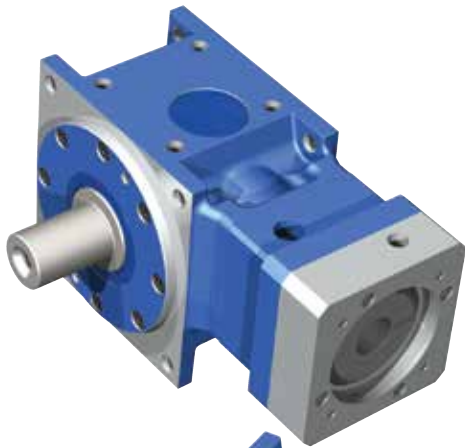

DS-W

- Single output shaft configuration with our high performance bellow coupling input and machined motor flange to mount to any servo motor
- Frame sizes from 55 mm to 190 mm
- ⚠ DSX option available

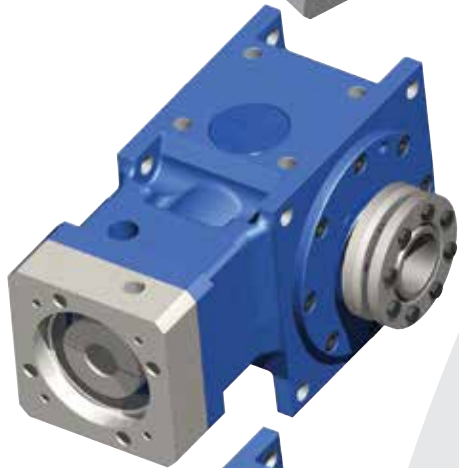

DS-H

- Hollow bore output configuration with our high performance bellow coupling input and machined motor flange to mount to any servo motor
- Zero-backlash shrink disk coupling on the output included with the gearbox
- Frame sizes from 55 mm to 190 mm
- ⚠ DSX option available

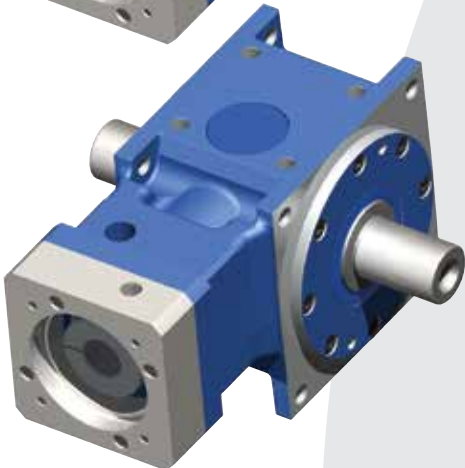

DS-T

- Dual output shaft configuration with our high performance bellow coupling input and machined motor flange to mount to any servo motor
- Frame sizes from 55 mm to 190 mm
- ⚠ DSX option available

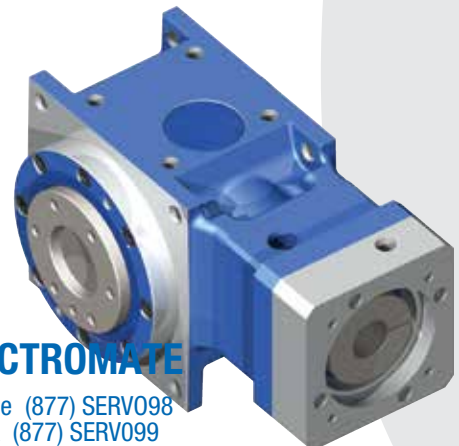

DS-F

- Flange output allows connection of pinion gears, pulleys, rotary index tables, and transmission shafting directly to the output for a more compact and stiffer solution
- Frame sizes from 55 mm to 190 mm
- ⚠ DSX option available

Sold & Serviced By:



Toll Free Phone (877) SERV098
Toll Free Fax (877) SERV099
www.electromate.com
sales@electromate.com



▶ HIGHEST PERFORMANCE: DYNA SERIES

The Advantage of Hypoid Gearing

The GAM Hypoid offers significant advantages over other conventional right-angle gears.

Conventional spiral bevel gearing, meshing in the position shown at the bottom of the drawing, has a purely rolling meshing action that is mechanically very efficient. Its drawback is that it offers the smallest total tooth contact area, so its torque throughput capacity is lower. Single-stage spiral bevel gearing is limited to about a 6:1 reduction ratio. It's easy to get higher ratios with multiple-stage configurations, but the additional gear stage lowers mechanical efficiency, increases backlash, consumes space and weight and reduces reliability.

Conventional worm gearing, meshing in the position shown at the top of the drawing, has a very high total tooth contact area. While it offers high torque throughput and high ratio reduction, worm gearing has the lowest mechanical efficiency, due to the friction generated by its high component of sliding action. Worm gearing is also subject to the kind of wear that demands adjustment in order to maintain accuracy.

Hypoid gearing, meshing at the intermediate position, offers mostly rolling action with a small component of sliding action. It has a greater tooth contact area than bevel gearing, so its load-carrying capability is greater. The GAM Hypoid offers further advantages by going up to a 15:1 gear ratio in a single stage with efficiencies between 93% and 96%, depending upon ratio throughout the speed range. Another important design criterion for precision servo applications is, of course, low backlash in the gear box.

The GAM Hypoid offers two important advantages:

- Single-stage design eliminates backlash from a second set of meshing gears
- Accurate machining and assembly alignment – high-accuracy models offer backlash of ≤ 2 arcminutes.

GAM Hypoid gearing is available in two product ranges, our highest precision Dyna Series, and high precision, Dyna-Lite Series.

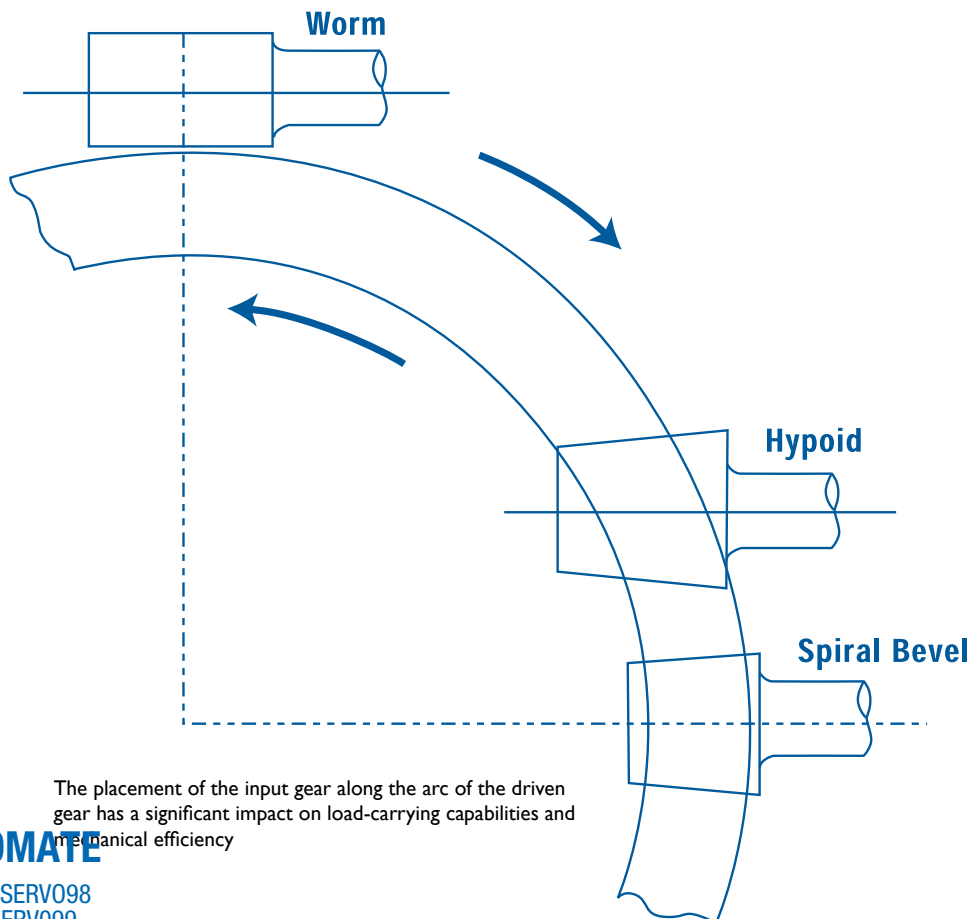

The placement of the input gear along the arc of the driven gear has a significant impact on load-carrying capabilities and mechanical efficiency

Sold & Serviced By:

ELECTROMATE

Toll Free Phone (877) SERV098

Toll Free Fax (877) SERV099

51 www.electromate.com

sales@electromate.com

HIGHEST PERFORMANCE: DYNA SERIES

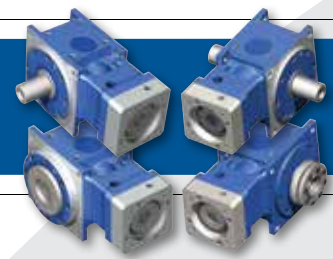

Dyna Series		55	75	90	115	140	190	
Stock Ratios ¹⁾		3, 5, 10, 15, 30, 50, 100			3, 5, 10, 15			N/A
All Ratios Available		1-stage: 3, 4, 5, 6, 8, 10, 12, 15			2-stage: 25, 30, 40, 50, 70, 100			3-stage: consult GAM
Nominal Output Torque (T_{2n})	Nm (lb-in)	3:1	35 (310)	70 (620)	140 (1239)	260 (2301)	700 (6196)	1400 (12391)
		4:1	34 (301)	68 (602)	136 (1204)	255 (2257)	690 (6107)	1350 (11949)
		5:1	33 (292)	65 (575)	131 (1159)	250 (2213)	670 (5930)	1280 (11329)
		6:1	32 (283)	61 (540)	124 (1097)	240 (2124)	660 (5841)	1200 (10621)
		8:1	30 (266)	56 (496)	115 (1018)	220 (1947)	640 (5664)	1120 (9913)
		10:1	28 (248)	53 (469)	105 (929)	200 (1770)	560 (4956)	1040 (9205)
		12:1	25 (221)	50 (443)	95 (841)	180 (1593)	480 (4248)	950 (8408)
		15:1	22 (195)	45 (398)	80 (708)	160 (1416)	400 (3540)	800 (7081)
	All 2-Stage Ratios	35 (310)	70 (620)	140 (1239)	260 (2301)	700 (6196)	1400 (12391)	
Max Acceleration Output Torque (T_{2a})	Nm (lb-in)	-	1.5 x Nominal	1.5 x Nominal	1.5 x Nominal	1.5 x Nominal	1.5 x Nominal	
Emergency Output Torque (T_{2not})	Nm (lb-in)	3:1-6:1	70 (620)	140 (1239)	280 (2478)	520 (4602)	1400 (12391)	2800 (24782)
		8:1-10:1	60 (531)	110 (974)	230 (2036)	440 (3894)	1280 (11329)	2240 (19826)
		12:1-15:1	50 (443)	100 (885)	190 (1682)	360 (3186)	960 (8497)	1900 (16816)
		All 2-Stage Ratios	70 (620)	140 (1239)	280 (2478)	520 (4602)	1400 (12391)	2800 (24782)
Nominal Input Speed ⁶⁾ (n_{in})	RPM	1 Stage	6000	6000	5000	4000	3000	2500
		2 Stage	3000	3000	3200	3200	2800	2500
Max Input Speed ⁶⁾ (n_{imax})	RPM	1 Stage	8000	8000	7000	6000	5000	4500
		2 Stage	6000	6000	6000	6000	6000	4500
Standard Output Backlash (j)	arcmin	1 Stage	<5	<5	<4	<4	<4	<4
		2 Stage	<7	<7	<6	<6	<6	<6
Reduced Output Backlash (j)	arcmin	1 Stage	<3	<3	<2	<2	<2	<2
		2 Stage	<4	<4	<3	<3	<3	<3
Noise Level (L_{pA})	dB	-	<70	<71	<74	<74	<74	
Allowable Radial Load ⁴⁾ (F_{rad})	N (lbs)	-	3500 (787)	3800 (854)	4000 (899)	7500 (1686)	11000 (2473)	15000 (3372)
Allowable Axial Load (F_{axial})	N (lbs)	-	1400 (315)	1520 (342)	1600 (360)	3000 (674)	4400 (989)	6000 (1349)
Maximum Tilting Moment	Nm (lb-in)	-	145 (1283)	173 (1531)	238 (2106)	510 (4513)	990 (8763)	1650 (14604)
Torsional Stiffness (C_{21}) ⁵⁾	Nm/arcmin (lb-in/arcmin)	1 Stage	2.1 (18.6)	4.2 (37.2)	10.5 (92.9)	23.4 (207.1)	61.8 (547.0)	126 (1115.2)
		2 Stage	2.1 (18.6)	4.2 (37.2)	10.2 (90.3)	22.8 (201.8)	60.1 (531.9)	119.2 (1055.0)
Weight (m)	kg (lbs)	1 Stage	3 (6.6)	6 (13.2)	10 (22.0)	17 (37.5)	39 (86.0)	55 (121.3)
		2 Stage	4 (8.8)	7 (15.4)	11 (24.3)	22 (48.5)	49 (108.0)	65 (143.3)
Mass Moment of Inertia	kg cm ² (lb-in ²)	3:1	0.584 (0.200)	1.32 (0.451)	3.41 (1.165)	8.49 (2.901)	29.7 (10.149)	91.3 (31.199)
		4:1	0.439 (0.150)	0.993 (0.339)	2.46 (0.841)	6.03 (2.061)	20 (6.834)	61.2 (20.913)
		5:1	0.357 (0.122)	0.834 (0.285)	1.98 (0.677)	4.79 (1.637)	14.7 (5.023)	45.1 (15.412)
		6:1	0.258 (0.088)	0.747 (0.255)	1.24 (0.424)	4.04 (1.381)	11.7 (3.998)	34.9 (11.926)
		8:1	0.214 (0.073)	0.654 (0.223)	0.958 (0.327)	3.36 (1.148)	9.08 (3.103)	25.8 (8.816)
		10:1	0.192 (0.066)	0.612 (0.209)	0.842 (0.288)	3.04 (1.039)	7.85 (2.683)	21.8 (7.449)
		12:1	0.181 (0.062)	0.592 (0.202)	0.78 (0.267)	2.87 (0.981)	7.14 (2.440)	19.6 (6.698)
		15:1	0.17 (0.058)	0.568 (0.194)	0.715 (0.244)	2.72 (0.929)	6.55 (2.238)	19.5 (6.664)
		30:1	0.405 (0.138)	0.487 (0.166)	1.309 (0.447)	4.043 (1.382)	7.100 (2.426)	13.944 (4.765)
		40:1	0.367 (0.126)	0.402 (0.137)	1.084 (0.370)	3.477 (1.188)	5.050 (1.726)	7.625 (2.606)
		50:1	0.354 (0.121)	0.373 (0.128)	1.009 (0.345)	3.292 (1.125)	4.388 (1.499)	5.604 (1.915)
		70:1	0.352 (0.120)	0.356 (0.122)	0.978 (0.334)	3.430 (1.172)	4.779 (1.633)	4.918 (1.681)
100:1	0.342 (0.117)	0.346 (0.118)	0.938 (0.321)	3.130 (1.070)	3.879 (1.325)	4.018 (1.373)		
Efficiency at Load		3:1 - 8:1 > 96%			10:1 - 15:1 > 93%	30:1 - 100:1 > 92%		
Service Life		>30,000 hours						
Lubrication		Synthetic Oil: ISO VG 100						
Protection Rating		IP 64						
Operating Temperature Range		-10°C to 90°C						

Sold & Serviced By: **ELECTROMATE**

Toll Free Phone (877) 567-0930
 Toll Free Fax (877) 567-0930
 www.electromate.com
 sales@electromate.com

1) Stock ratios listed are available in Standard AND Reduced Backlash. 2) Nominal torque and speed values listed are for gear tooth ratings. Use thermal limit for continuous operation. 3) DSX Precision grinding gearing for quieter and smoother operation, improved accuracy, and repeatability. 4) Load applied at center of output shaft @400 RPM. 5) Stiffness values relate to DS-W version only. Stiffness for DS-H,F may vary slightly- contact GAM for values. 6) Higher input speeds may be possible – consult GAM.



▶ DYNA SERIES - DS-W, DS-H, DS-T, DS-F

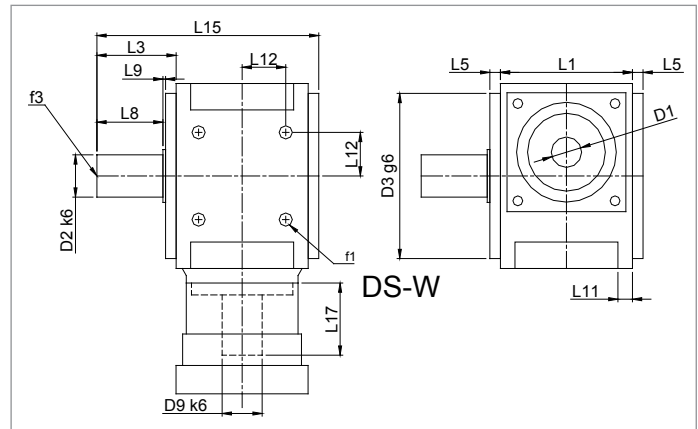
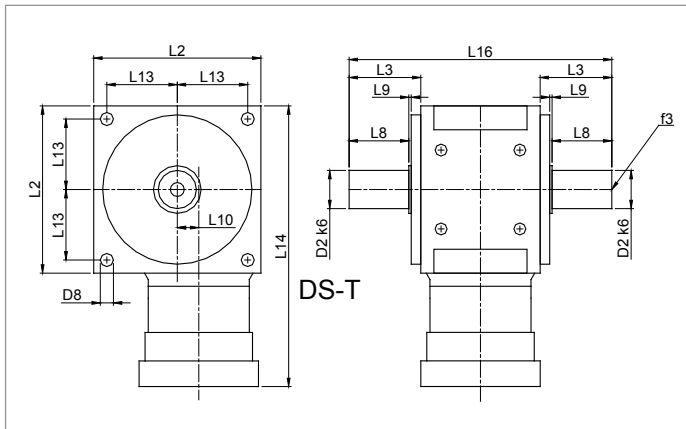
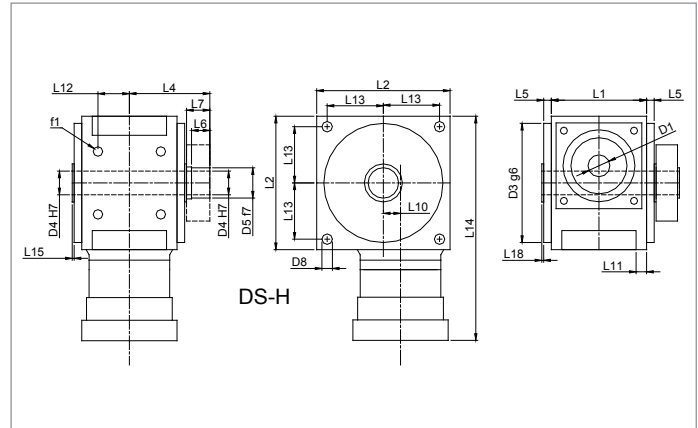
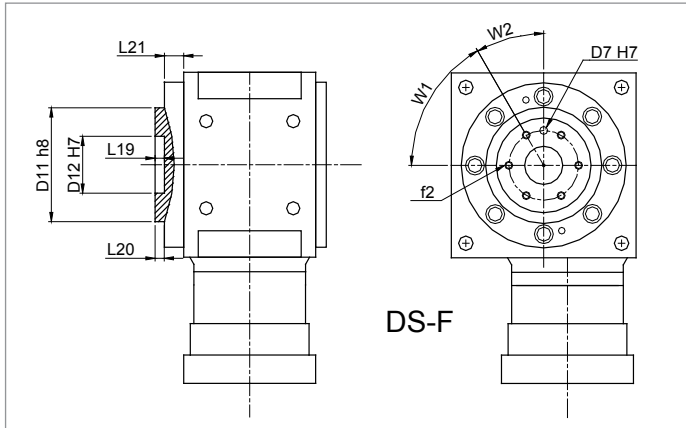

Recommended Output Coupling (if necessary)

metal bellows	KM-60	KM-170	KM-270	KM-400	KM-1300	KSD-2500
elastomer	EKM-60	EKM-150	EKM-300	EKM-500	EKM-1000	-

TYPE CODES FOR DYNA SERIES

Example: DS - W B - 090 - 005 G - [115-201] - S111

Gearbox Series
DS = Dyna Series
DSX = Dyna Series Extreme

Gearbox Style
W = Single output shaft
T = Dual output shaft
H = Hollow output shaft
F = Flange output

Input Type
B = Bellows coupling input
E = Elastomer coupling input
L = Shaft input

Gearbox Size
055, 075, 090, 115, 130, 140, 160, 190

Ratio
003, 004, 005, 006, 008, 010,
015, 020, 030, 040, 050, 070, 100

Special Options
Assigned by GAM

Motor Mount Kit
Assigned by GAM

Options Available for This Product

	LOW	OUTPUT
OPTION	BACKLASH	KEYWAY
A=	Y	N
C=	Y	Y
G=	N	Y
H=	N	N

Options C and G N/A for DS-F/H models.

Tolerances (mm)

Size	k6	g6	h8	f7	H7	h6
Over 6	+0.010	-0.005	0	-0.013	+0.015	0
Thru 10	+0.001	-0.014	-0.022	-0.028	0	-0.009
Over 10	+0.012	-0.006	0	-0.016	+0.018	0
Thru 18	+0.001	-0.017	-0.027	-0.034	0	-0.011
Over 18	+0.015	-0.007	0	-0.02	+0.021	0
Thru 30	+0.002	-0.020	-0.033	-0.041	0	-0.013
Over 30	+0.018	-0.009	0	-0.025	+0.025	0
Thru 50	+0.002	-0.025	-0.039	-0.05	0	-0.016
Over 50	+0.021	-0.010	0	-0.03	+0.030	0
Thru 80	+0.002	-0.029	-0.046	-0.06	0	-0.019
Over 80	+0.025	-0.012	0	-0.036	+0.035	0
Thru 120	+0.003	-0.034	-0.054	-0.021	0	-0.022
Over 120	+0.028	-0.014	0	-0.043	+0.040	0
Thru 180	+0.003	-0.039	-0.063	-0.083	0	-0.025

Dyna Series		55		75		90		115		140		190	
		mm	(in)	mm	(in)	mm	(in)	mm	(in)	mm	(in)	mm	(in)
D1 _{max 1-stage*}	input shaft diameter	21	(0.827)	28	(1.102)	35	(1.378)	43	(1.693)	55	(2.165)	55	(2.165)
D1 _{max 2-stage*}		14	(0.551)	14	(0.551)	24	(0.945)	24	(0.945)	38	(1.496)	38	(1.496)
D3 g6	pilot diameter	89	(3.504)	105	(4.134)	125	(4.921)	150	(5.906)	195	(7.677)	245	(9.646)
D8	mounting hole diameter	6.6	(0.26)	9	(0.354)	11	(0.433)	14	(0.551)	17.5	(0.689)	17.5	(0.689)
D9 k6	gearbox input shaft dia	14	(0.551)	18	(0.709)	22	(0.866)	28	(1.102)	32	(1.26)	40	(1.575)
f1	mounting hole thread	M6		M8		M10		M12		M16		M16	
L1	housing width	60	(2.362)	80	(3.15)	100	(3.937)	120	(4.724)	146	(5.748)	196	(7.717)
L2	housing size	90	(3.543)	115	(4.528)	140	(5.512)	170	(6.693)	215	(8.465)	260	(10.236)
L5	pilot height	13.5	(0.531)	8.5	(0.335)	8	(0.315)	8	(0.315)	10	(0.394)	10	(0.394)
L10	hypoid offset	9	(0.354)	14	(0.551)	18	(0.709)	23	(0.906)	32	(1.26)	42	(1.654)
L11	flange thickness	8	(0.315)	10	(0.394)	11	(0.433)	13	(0.512)	15	(0.591)	17	(0.669)
L12	hole location	22	(0.866)	27	(1.063)	33	(1.299)	40	(1.575)	52	(2.047)	70	(2.756)
L13	hole location	39	(1.535)	49	(1.929)	59	(2.323)	72	(2.835)	91	(3.583)	112	(4.409)
L14 1-stage**	input length	181	(7.126)	219	(8.622)	250.5	(9.862)	286.5	(11.28)	363.5	(14.311)	439	(17.283)
L14 2-stage**		229.5	(9.035)	262	(10.315)	247.5	(9.744)	280	(11.024)	372	(14.646)	591	(23.268)
L17	input shaft length	20	(0.787)	26	(1.024)	43	(1.693)	48	(1.89)	55	(2.165)	62	(2.441)

* for larger shaft diameters consult GAM ** depending on motor, length may vary

DS-F & DS-H		55		75		90		115		140		190	
		mm	(in)	mm	(in)	mm	(in)	mm	(in)	mm	(in)	mm	(in)
D4 H7**	hollow bore	20	(0.787)	25	(0.984)	30	(1.181)	40	(1.575)	55	(2.165)	70	(2.756)
D5 f7	hollow outer diameter	24	(0.945)	30	(1.181)	36	(1.417)	50	(1.969)	68	(2.677)	80	(3.15)
D6	flange bolt circle	40	(1.575)	50	(1.969)	63	(2.48)	80	(3.15)	100	(3.937)	125	(4.921)
D7 H7	locating hole diameter	6	(0.236)	6	(0.236)	6	(0.236)	8	(0.315)	8	(0.315)	10	(0.394)
D11 h8	flange pilot (OD)	50	(1.969)	63	(2.48)	80	(3.15)	100	(3.937)	125	(4.921)	160	(6.299)
D12 H7	flange pilot (ID)	25	(0.984)	31.5	(1.24)	40	(1.575)	50	(1.969)	63	(2.48)	80	(3.15)
f2	flange tapped holes	7 x M6x9		7 x M6x9		7 x M6x9		11 x M8x12		11 x M8x12		11 x M10x15	
L4	hollow hub length	73	(2.874)	81	(3.189)	95	(3.74)	109	(4.291)	129	(5.079)	161	(6.339)
L6	hub length	20	(0.787)	22	(0.866)	26	(1.024)	29	(1.142)	32	(1.26)	34	(1.339)
L7	shoulder + hub length	23	(0.906)	25	(0.984)	29	(1.142)	33	(1.299)	37	(1.457)	40	(1.575)
L18	shoulder height	1.5	(0.059)	1.5	(0.059)	2	(0.079)	2	(0.079)	2	(0.079)	2	(0.079)
L19	inner flange pilot depth	6.5	(0.256)	6.5	(0.256)	6.5	(0.256)	8.5	(0.335)	8.5	(0.335)	10.5	(0.413)
L20	outer flange pilot height	6.5	(0.256)	6.5	(0.256)	6.5	(0.256)	8.5	(0.335)	8.5	(0.335)	8.5	(0.335)
L21	pilot height	20	(0.787)	15.5	(0.61)	17	(0.669)	20	(0.787)	17.5	(0.689)	22.5	(0.886)
W1	hole angle 1	45°		45°		45°		30°		30°		30°	
W2	hole angle 2	45°		45°		45°		30°		30°		30°	

* for larger shaft diameters, consult GAM ** mating shaft should have h6 tolerance *** depending on motor, length may vary

DS-W & DS-T		55		75		90		115		140		190	
		mm	(in)	mm	(in)	mm	(in)	mm	(in)	mm	(in)	mm	(in)
D2 k6	output shaft diameter	20	(0.787)	24	(0.945)	32	(1.26)	40	(1.575)	55	(2.165)	70	(2.756)
f3	shaft thread per DIN332/1	M6x16		M8x19		M12x28		M16x36		M20x42		M20x42	
L3	output shaft length	50	(1.969)	50	(1.969)	60	(2.362)	70	(2.756)	102	(4.016)	122	(4.803)
L8	usable shaft length	35	(1.378)	40	(1.575)	50	(1.969)	60	(2.362)	90	(3.543)	110	(4.331)
L9	shoulder height	1.5	(0.059)	1.5	(0.059)	2	(0.079)	2	(0.079)	2	(0.079)	2	(0.079)
L15	gearbox width	123.5	(4.862)	138.5	(5.453)	168	(6.614)	198	(7.795)	258	(10.157)	328	(12.913)
L16	gearbox width	160	(6.299)	180	(7.087)	220	(8.661)	260	(10.236)	350	(13.78)	440	(17.323)

* for larger shaft diameters consult GAM ** depending on motor, length may vary



▶ HIGH PERFORMANCE: DYNA-LITE SERIES

GAM can.

If you don't see exactly what you need, let us know. We can modify the Dyna-Lite Series gearboxes to meet your needs. Page 4 provides a list of commonly requested modifications to give you a feel for our capabilities.

Now there's a right-angle gearbox that has the performance and price point of a precision in-line gearbox. Our redesigned Dyna-Lite Series use hypoid gearing that combines the space and configuration advantages of worm gearing with the high efficiency of bevel gearing. It is drop-in replacement for many right-angle and in-line planetary gear reducers.

Dyna-Lite Series benefits include:

- High efficiency – 96%
- Standard backlash < 6 arcmin
- Back drivable
- High radial loading
- Available in shaft output and hollow output

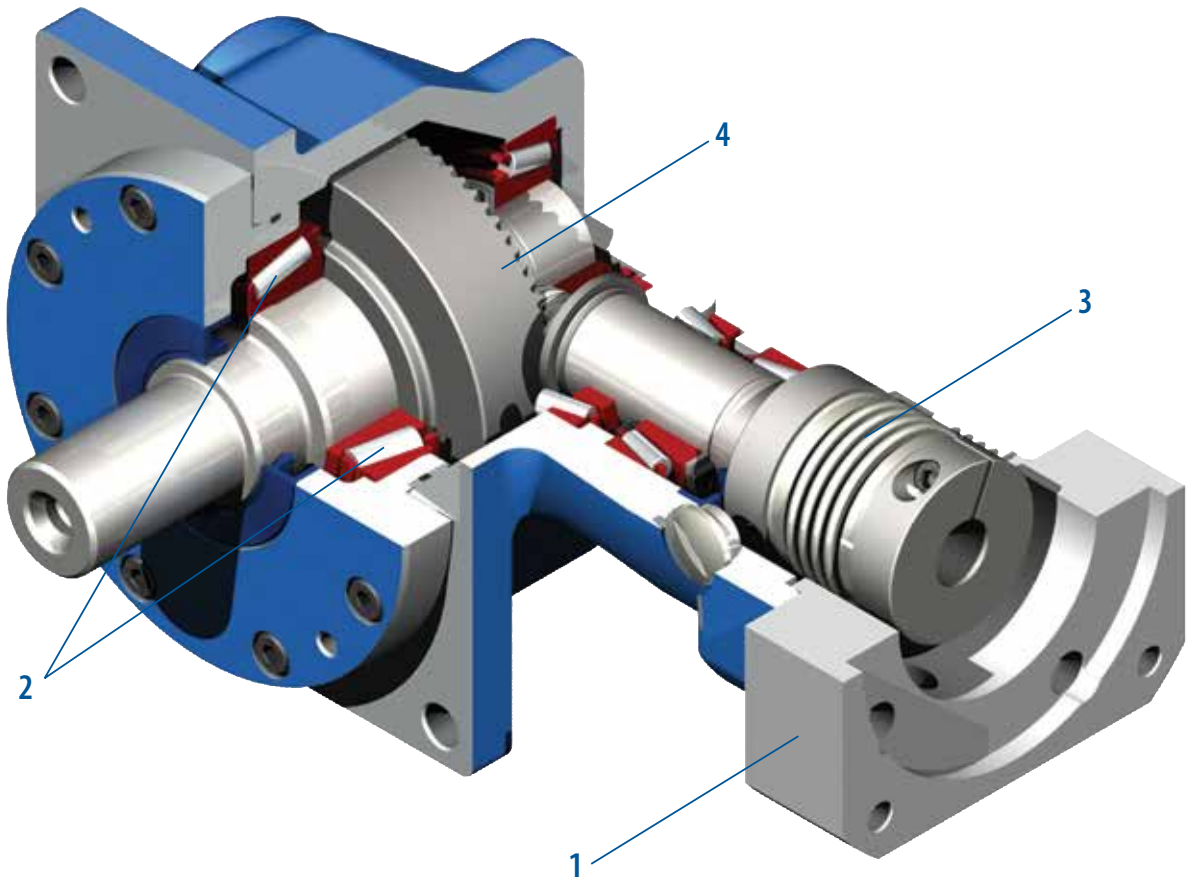

1. Adapter Plate
(Allows for quick and easy motor mounting)

2. Bearings
(Upper roller bearings allows high radial loading of output shaft)

3. Bellows Coupling
(Bellows coupling for quick motor mounting)

4. Hypoid Gearing
(Optimized gearing allows ratios up to 15:1 in a single stage; 150:1 in two stages)

Sold & Serviced By:

 **ELECTROMATE**

Toll Free Phone (877) SERV098

Toll Free Fax (877) SERV099

55 www.electromate.com
sales@electromate.com

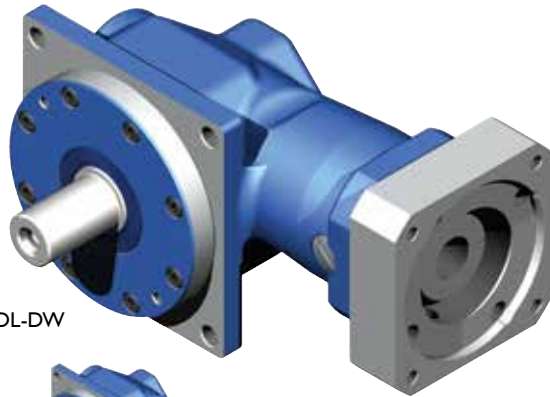

DL-DW



DL-DW High Ratio
(High Ratio available on all versions)

DL-DW

- Single output shaft configuration with our high performance bellow coupling
- Input and housing to mount to any servo motor
- Ratios up to 15:1 in a single stage and 150:1 in two stages
- Frame sizes: 55, 75 and 90 mm
- Drop-in for our highest precision Dyna Series

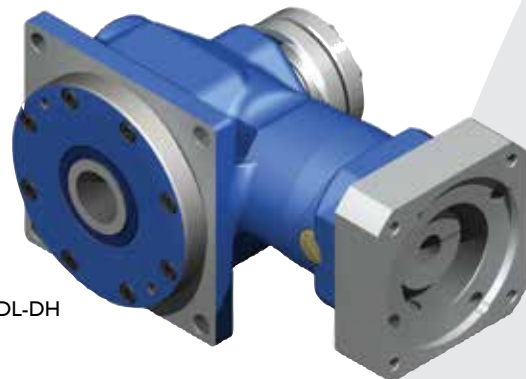

DL-DH

DL-DH

- Smooth hollow output shaft configuration (includes shrink disc)
- Input and housing to mount to any servo motor
- Ratios up to 15:1 in a single stage and 150:1 in two stages
- Frame sizes: 55, 75 and 90 mm
- Drop-in for our highest precision Dyna Series

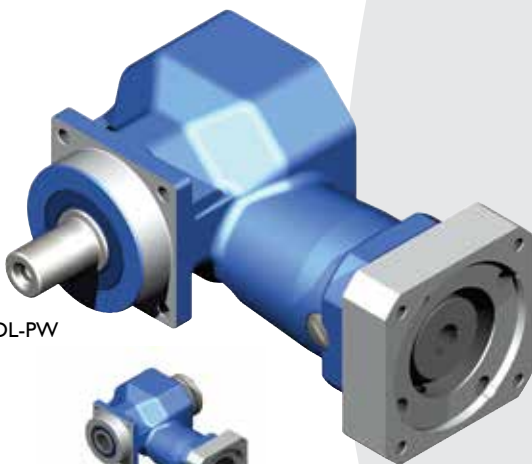

DL-PW

DL-PW

- Single output shaft configuration with our high performance bellow coupling
- Input and housing to mount to any servo motor
- Ratios up to 15:1 in a single stage and 150:1 in two stages
- Frame sizes: 55, 75 and 90 mm
- Drop-in for many right-angle and in-line planetary gear reducers
- Rotation direction is opposite for DW and PW models.

DL-PH
(Available upon request)

DL-PH (Contact GAM for availability)

- Smooth hollow output shaft configuration (includes shrink disc)



▶ DYNA-LITE SERIES - DL-D



Dyna-Lite Series			55	75	90
Stock Ratios			5, 10, 25, 50, 100, 150		
All Ratios Available*			1-stage: 5, 10, 15 2-stage: 25, 50, 100, 150* For other ratios, consult GAM.		
Nominal Output Torque (T_{2n})	Nm (lb-in)	5:1, 10:1, 25:1, 50:1, 100:1	35 (310)	70 (620)	140 (1239)
		15:1, 150:1	25 (221)	50 (443)	90 (797)
Max Acceleration Output Torque (T_{2a})	Nm (lb-in)	5:1, 10:1, 25:1, 50:1, 100:1	53 (469)	105 (929)	210 (1859)
		15:1, 150:1	38 (336)	75 (664)	143 (1266)
Emergency Output Torque (T_{2not})	Nm (lb-in)	5:1, 10:1, 25:1, 50:1, 100:1	70 (620)	140 (1239)	280 (2478)
		15:1, 150:1	50 (443)	100 (885)	190 (1682)
Nominal Input Speed (n_{1n})	RPM	5:1	3700	3100	2700
		10:1, 15:1	4200	3500	3000
		2-stage	3500	3000	3000
Max Input Speed (n_{1max})	RPM		6000	6000	5000
Standard Output Backlash (j)	arcmin	1-stage	< 7	< 7	< 6
		2-stage	< 9	< 9	< 8
Allowable Radial Load (F_{rad}) ¹⁾	N (lbs)		3300 (743)	4900 (1103)	7200 (1620)
Allowable Axial Load (F_{axial})	N (lbs)		1650 (371)	2450 (551)	3600 (810)
Torsional Stiffness (C_{t21})	Nm/arcmin		1.5	4.0	10.0
	(lb-in/arcmin)		(13.28)	(35.40)	(88.51)
Weight (m)	kg (lbs)	1-stage	2.6 (5.7)	4.5 (9.9)	9 (19.8)
		2-stage	3.6 (7.9)	6.8 (15)	14.8 (32.6)
Noise Level (L_{pA})	dB(A)	1-stage	< 66	< 66	< 68
		2-stage	< 69	< 70	< 72
Mass Moment of Inertia (J_1)	kg cm ² (lb-in ²)	5:1	0.44 (0.15)	1.06 (0.36)	3.6 (1.224)
		10:1, 15:1	0.35 (0.119)	0.84 (0.286)	2.9 (0.986)
		25:1	0.17 (0.058)	0.45 (0.153)	1.65 (0.561)
		50:1, 100:1	0.14 (0.048)	0.34 (0.116)	1.1 (0.374)
Efficiency at Load		5,10: 96%	15: 93%	25,50,100,150: 87%	
Service Life		>15000 hours			
Lubrication		Life Time Lubrication			
Protection Rating		IP 64			
Operating Temperature Range		-10°C to 100°C (14°F to 212°F)			

1) Load applied at center of output shaft @100 RPM

* other ratios available

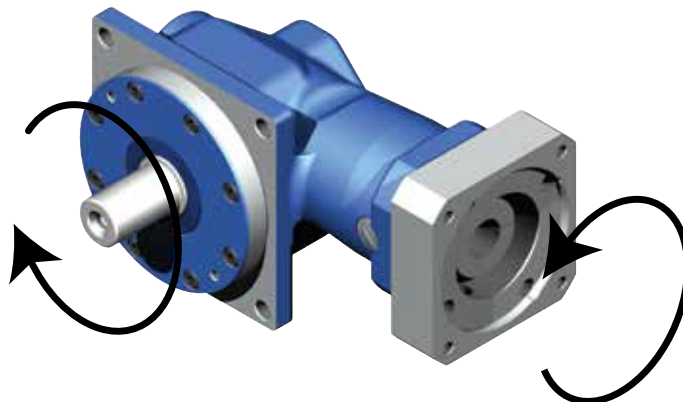

Sold & Serviced By:
 ELECTROMATE

Toll Free Phone (877) SERV098

Toll Free Fax (877) SERV099

57 www.electromate.com

sales@electromate.com

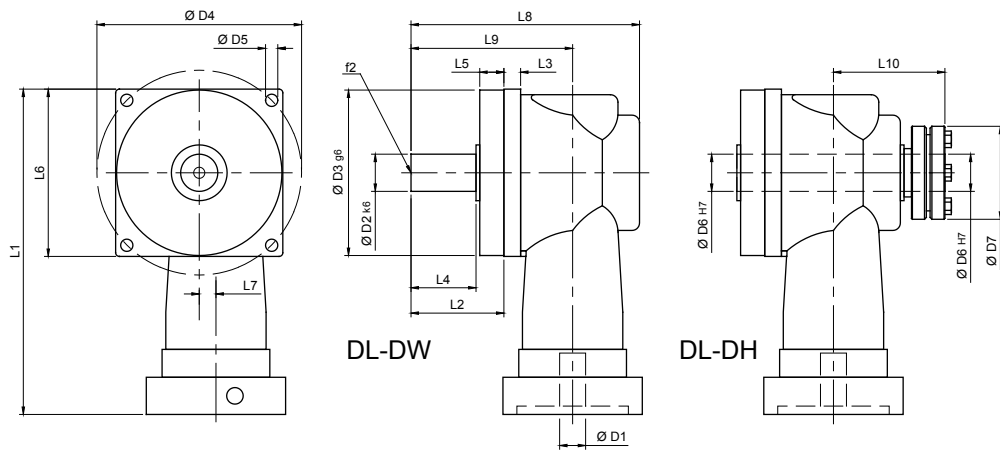

DL - DW and DL - DH		55		75		90	
		mm	(in)	mm	(in)	mm	(in)
D1 _{max (1 stage)*}	motor shaft diameter	16	(0.63)	20	(0.787)	35	(1.378)
D1 _{max (2 stage standard)*}	motor shaft diameter	14	(0.551)	19	(0.748)	19	(0.748)
D1 _{max (2 stage available)*}	motor shaft diameter	16	(0.63)	24	(0.945)	24	(0.945)
D2 k6	output shaft diameter	20	(0.787)	24	(0.945)	32	(1.26)
D3 g6	pilot diameter	89	(3.504)	105	(4.134)	125	(4.921)
D4	bolt circle	110.3	(4.343)	138.6	(5.457)	166.8	(6.567)
D5	mounting holes	6.6	(0.26)	9	(0.354)	11	(0.433)
D6 H7**	hollow bore diameter	20	(0.787)	25	(0.984)	30	(1.181)
D7	shrink disc OD (included)	50	(1.97)	60	(2.36)	72	(2.83)
L1 1-stage***	gearbox length	175	(6.89)	213.5	(8.406)	257	(10.118)
L1 2-stage***		236	(9.291)	304.5	(11.99)	336	(13.23)
L2	shaft length	50.0	(1.969)	55	(2.165)	68	(2.677)
L3	flange thickness	9	(0.354)	11	(0.433)	14	(0.551)
L4	usable shaft length	35	(1.378)	40	(1.575)	50	(1.969)
L5	pilot height	13	(0.512)	13	(0.512)	16	(0.63)
L6	flange size	90	(3.543)	115	(4.528)	140	(5.512)
L7	gear offset	9	(0.354)	14	(0.551)	18	(0.709)
L8	gearbox width	123	(4.843)	142	(5.591)	175	(6.89)
L9	shaft to centerline	87	(3.425)	100	(3.937)	126	(4.961)
L10	shrink disc to centerline	64.5	(2.539)	73.5	(2.894)	87	(3.425)
f2	shaft thread per DIN332/1	M6 x 16		M8 x 19		M12 x 28	

* for larger motor shaft diameters, please contact GAM **mating shaft should have h6 tolerance ***depending on motor, length may vary



Recommended Output Coupling (if necessary)

metal bellows	KLC-50	KLC-125	KM-270
elastomer	EKC-80	EKC-110	EKM-300

TYPE CODES FOR DYNA-LITE SERIES (DL-D)

Example: DL - DW - 075 - 005 H - [090 - 15A] - S111

Gearbox Series

DL = Dyna-Lite

Gearbox Style

DW = shaft output

DH = hollow output

Gearbox Size

055, 075, 090

Ratio

Special Options

Assigned by GAM

Motor Mount Kit

Assigned by GAM

Options Available for This Product

G = Keyed output shaft

H = Smooth output shaft

Tolerances (mm)			
Size	k6	g6	H7
Over 18	+0.015	-0.007	+0.021
Thru 30	+0.002	-0.020	0
Over 30	+0.018	-0.009	+0.025
Thru 50	+0.002	-0.025	0
Over 50	+0.021	-0.010	+0.030
Thru 80	+0.002	-0.029	0
Over 80	+0.025	-0.012	+0.035
Thru 120	+0.003	-0.034	0
Over 120	+0.028	-0.014	+0.040
Thru 180	+0.003	-0.039	0

Sold & Serviced By:

ELECTROMATE

Toll Free Phone (877) SERV099

Toll Free Fax (877) SERV099

www.electromate.com

sales@electromate.com



▶ DYNA-LITE SERIES - DL-P

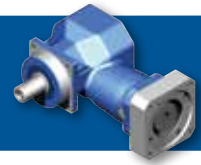

Dyna-Lite Series			55	75	90
Stock Ratios			5, 10, 25, 50, 100, 150		
All Ratios Available*			1-stage: 5, 10, 15 2-stage: 25, 50, 100, 150* For other ratios, consult GAM.		
Nominal Output Torque (T_{2n})	Nm (lb-in)	5:1, 10:1, 25:1, 50:1, 100:1	35 (310)	70 (620)	140 (1239)
		15:1, 150:1	25 (221)	50 (443)	90 (797)
Max Acceleration Output Torque (T_{2a})	Nm (lb-in)	5:1, 10:1, 25:1, 50:1, 100:1	53 (469)	105 (929)	210 (1859)
		15:1, 150:1	38 (336)	75 (664)	143 (1266)
Emergency Output Torque (T_{2not})	Nm (lb-in)	5:1, 10:1, 25:1, 50:1, 100:1	70 (620)	140 (1239)	280 (2478)
		15:1, 150:1	50 (443)	100 (885)	190 (1682)
Nominal Input Speed (n_{1n})	RPM	5:1	3700	3100	2700
		10:1, 15:1	4200	3500	3000
		2-stage	3500	3000	3000
Max Input Speed (n_{1max})	RPM		6000	6000	5000
Standard Output Backlash (j)	arcmin	1-stage	< 7	< 7	< 6
		2-stage	< 9	< 9	< 8
Allowable Radial Load (F_{rad}) ¹⁾	N (lbs)		2200 (495)	4050 (911)	6200 (1395)
Allowable Axial Load (F_{axial})	N (lbs)		1100 (248)	2025 (456)	3100 (698)
Torsional Stiffness (C_{21})	Nm/arcmin		1.5	4.0	10.0
	(lb-in/arcmin)		(13.28)	(35.40)	(88.51)
Weight (m)	kg (lbs)	1-stage	2.6 (5.7)	4.5 (9.9)	9 (19.8)
		2-stage	3.6 (7.9)	6.8 (15)	14.8 (32.6)
Noise Level (L_{pA})	dB(A)	1-stage	< 66	< 66	< 68
		2-stage	< 69	< 70	< 72
Mass Moment of Inertia (J_1)	kg cm ² (lb-in ²)	5:1	0.44 (0.15)	1.08 (0.37)	3.7 (1.258)
		10:1, 15:1	0.35 (0.119)	0.84 (0.286)	2.9 (0.986)
		25:1	0.17 (0.058)	0.45 (0.153)	1.65 (0.561)
		50:1, 100:1	0.14 (0.048)	0.34 (0.116)	1.1 (0.374)
Efficiency at Load		5,10: 96%	15: 93%	25,50,100,150: 87%	
Service Life		>15000 hours			
Lubrication		Life Time Lubrication			
Protection Rating		IP 64			
Operating Temperature Range		-10°C to 100°C (14°F to 212°F)			

1) Load applied at center of output shaft @100 RPM

* other ratios available

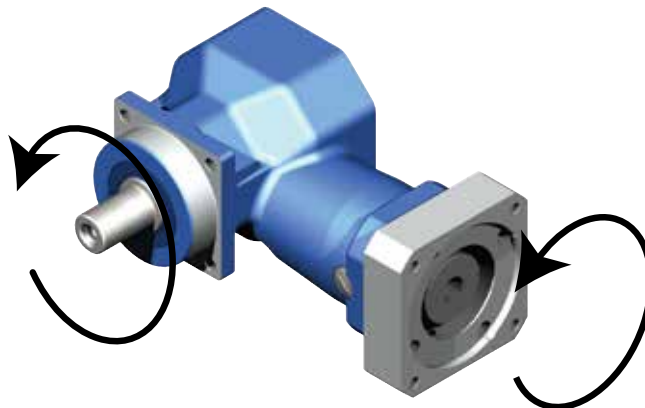

Sold & Serviced By:

Toll Free Phone (877) SERV098
 Toll Free Fax (877) SERV099

59 www.electromate.com
sales@electromate.com

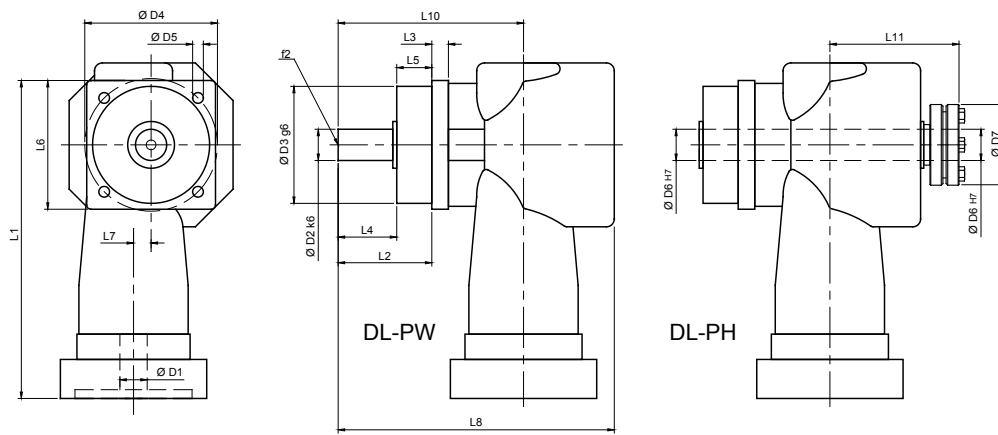

DL - PW and DL - PH		55		75		90	
		mm	(in)	mm	(in)	mm	(in)
D1 _{max} (1 stage)*	motor shaft diameter	16	(0.63)	20	(0.787)	35	(1.378)
D1 _{max} (2 stage standard)*	motor shaft diameter	14	(0.551)	19	(0.748)	19	(0.748)
D1 _{max} (2 stage available)*	motor shaft diameter	16	(0.63)	24	(0.945)	24	(0.945)
D2 k6	output shaft diameter	16	(0.63)	22	(0.866)	32	(1.26)
D3 g6	pilot diameter	60	(2.362)	70	(2.756)	90	(3.543)
D4	bolt circle	68	(2.677)	85	(3.346)	120	(4.724)
D5	mounting holes	5.5	(0.217)	6.6	(0.26)	9	(0.354)
D6 H7**	hollow bore diameter	15	(0.591)	20	(0.787)	30	(1.181)
D7	shrink disc OD (included)	44	(1.732)	50	(1.969)	72	(2.835)
L1 1-stage***	gearbox length	172	(6.772)	206	(8.11)	249.5	(9.823)
L1 2-stage***		236	(9.291)	304.5	(11.99)	336	(13.23)
L2	shaft length	48.0	(1.89)	56	(2.205)	80	(3.15)
L3	flange thickness	8.5	(0.335)	10	(0.394)	13	(0.512)
L4	usable shaft length	28	(1.102)	36	(1.417)	58	(2.283)
L5	pilot height	18	(0.709)	18	(0.709)	20	(0.787)
L6	flange size	66	(2.598)	76	(2.992)	101	(3.976)
L7	gear offset	9	(0.354)	14	(0.551)	18	(0.709)
L8	gearbox width	141.5	(5.571)	166	(6.535)	216	(8.504)
L10	shaft to centerline	95	(3.740)	110	(4.331)	148	(5.827)
L11	shrink disc to centerline	estimated 70	(2.756)	estimated 86	(3.386)	estimated 108	(4.252)
F2	shaft thread per DIN332/1	M6 x 16		M8 x 19		M12x28	

* for larger motor shaft diameters, please contact GAM **mating shaft should have h6 tolerance ***depending on motor, length may vary

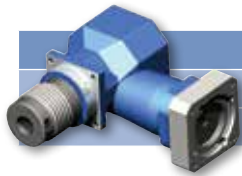

Recommended Output Coupling (if necessary)

metal bellows	KLC-50	KLC-125	KM-270
elastomer	EKC-80	EKC-110	EKM-300

TYPE CODES FOR DYNA-LITE SERIES (DL-P)

Example: DL - PW - 075 - 005 H - [090 - 15A] - S111

Gearbox Series

DL = Dyna-Lite

Gearbox Style

PW = shaft output

PH = hollow output

Gearbox Size

055, 075, 090

Ratio

1:1, 1.5:1, 2:1, 3:1, 4:1, 5:1, 6:1, 10:1

Special Options

Assigned by GAM

Motor Mount Kit

Assigned by GAM

Options Available for This Product

G = Keyed output shaft

H = Smooth output shaft

Size	Tolerances (mm)		
	k6	g6	H7
Over 18	+0.015	-0.007	+0.021
Thru 30	+0.002	-0.020	0
Over 30	+0.018	-0.009	+0.025
Thru 50	+0.002	-0.025	0
Over 50	+0.021	-0.010	+0.030
Thru 80	+0.002	-0.029	0
Over 80	+0.025	-0.012	+0.035
Thru 120	+0.003	-0.034	0
Over 120	+0.028	-0.014	+0.040
Thru 180	+0.003	-0.039	0

Sold & Serviced By:

ELECTROMATE

Toll Free Phone (877) SERVO99

Toll Free Fax (877) SERVO99

www.electromate.com

sales@electromate.com



▶ PERFORMANCE: SPIRAL BEVEL SERIES

GAM can.

If you don't see exactly what you need, let us know. We can modify the VC Series gearboxes to meet your needs. Page 4 provides a list of commonly requested modifications to give you a feel for our capabilities.

GAM Spiral Bevel Gearboxes

When you need a spiral bevel gearbox that you can count on, choose GAM. Our spiral bevel gearboxes are highly configurable, reliable, and economical right angle solutions designed for use in a wide range of applications. Precision cut spiral bevel gears are hardened and then lapped in pairs for ideal tooth contact and torque transmission, enabling 94-98% efficiencies and backlash between 10 and 30 arcmin (Reduced backlash versions available). Offered in 11 frame sizes, they can be constructed with a multitude of shaft configurations, and oriented in any direction to easily incorporate into your machine design.

VC spiral bevel series shown with integrated motor mount.

- High efficiencies 94-98%
- Lubricated for life with synthetic oil
- Includes motor mount

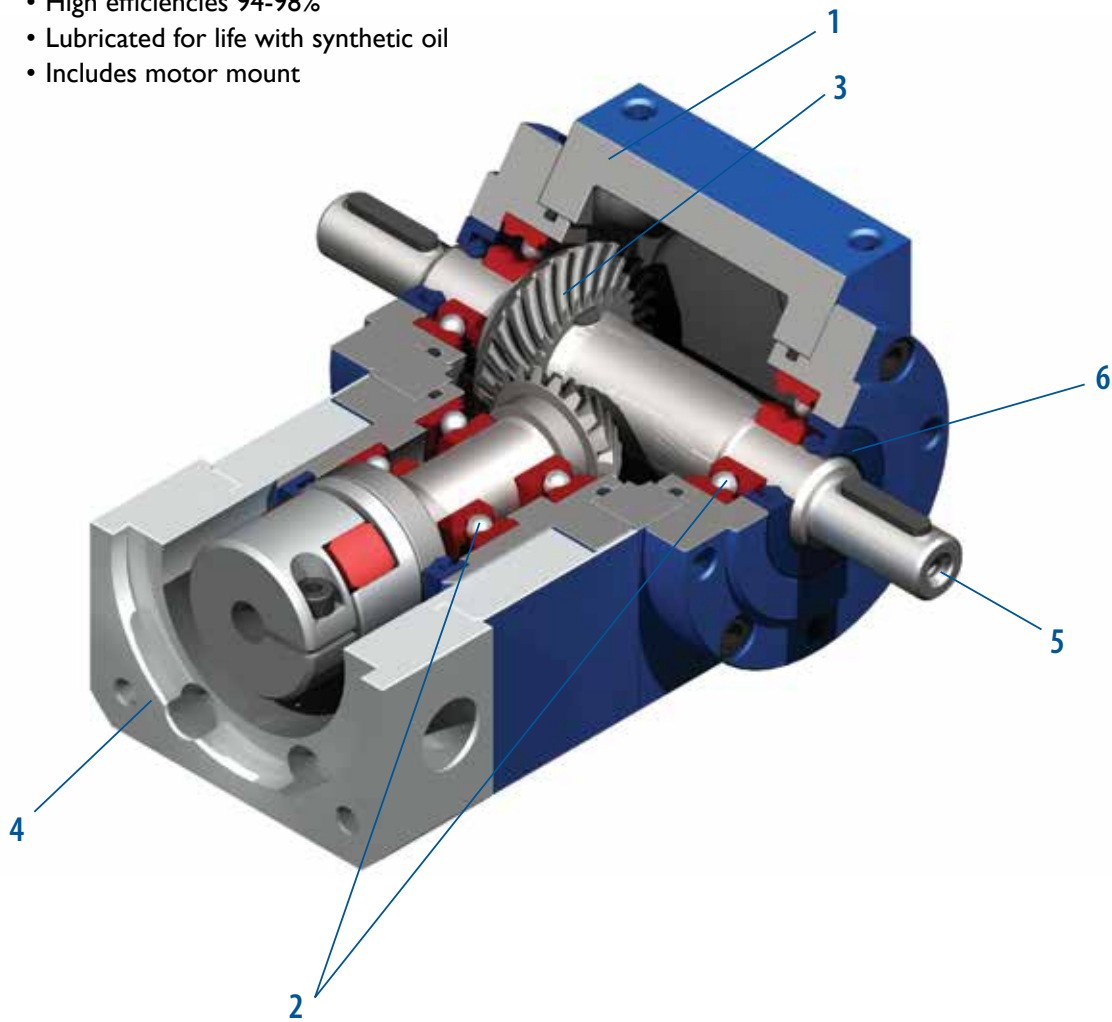

1. Housing

Sturdy cast iron housing
(Aluminum in size 35mm and 45mm)
- all 6 sides can be used for mounting

2. Bearings

Deep groove ball bearings handle axial and radial loading. (Reinforced and taper roller options available)

3. Spiral Bevel Gearing

Precision cut, hardened, and lapped in pairs for ideal tooth contact. Mathematically precise ratios from 1:1 to 6:1

4. Input

Available with shaft input or integrated motor adapter and coupling to easily mount to any IEC, NEMA, or servo motor

5. Output

Solid shaft with key or keyed hollow shaft are standard. (Smooth shaft or shrink disc clamping available)

6. Seals

Lubricated for life and protected with high quality NBR seals. (Viton® and FPM seals available)

Sold & Serviced By:

 **ELECTROMATE**

Toll Free Phone (877) SERV098
Toll Free Fax (877) SERV099

61 www.electromate.com
sales@electromate.com

Shaft Input

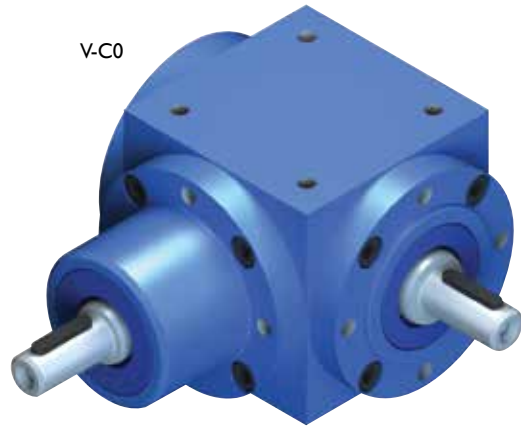

V-C0

V-Series
(65mm to 350mm)



L-C0

L-Series
("mini" 35mm & 45mm)

Available Models

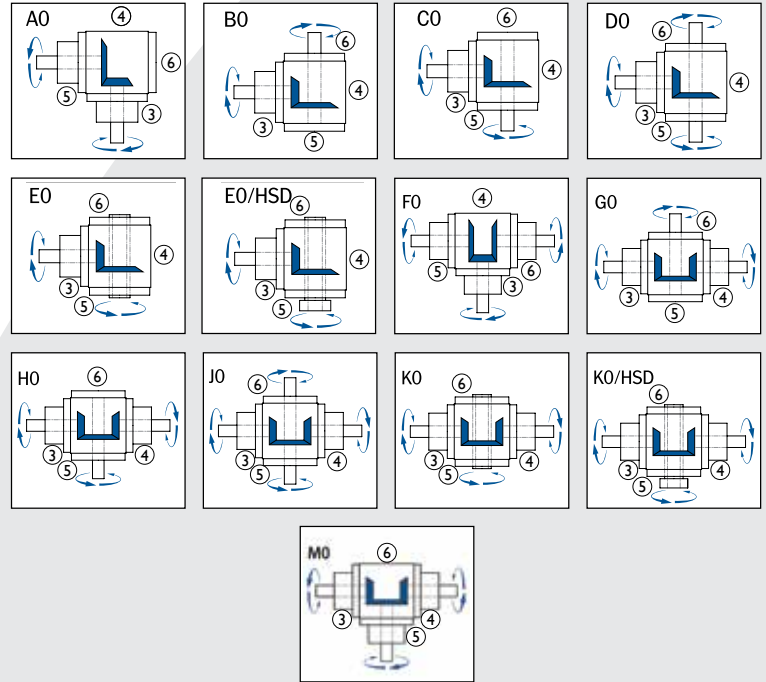

Integrated Motor Mount Input

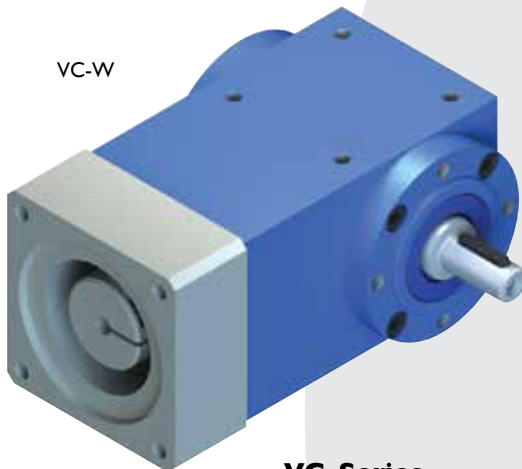

VC-W

VC-Series
(65mm to 200mm)

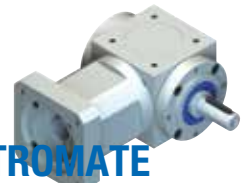

LL-W

LL-Series
("mini" 35mm & 45mm)

Available Models

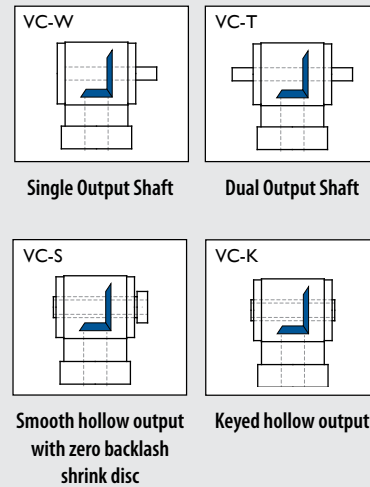

Sold & Serviced By:



Toll Free Phone (877) SERV098

Toll Free Fax (877) SERV099

www.electromate.com

sales@electromate.com



V SERIES & L SERIES

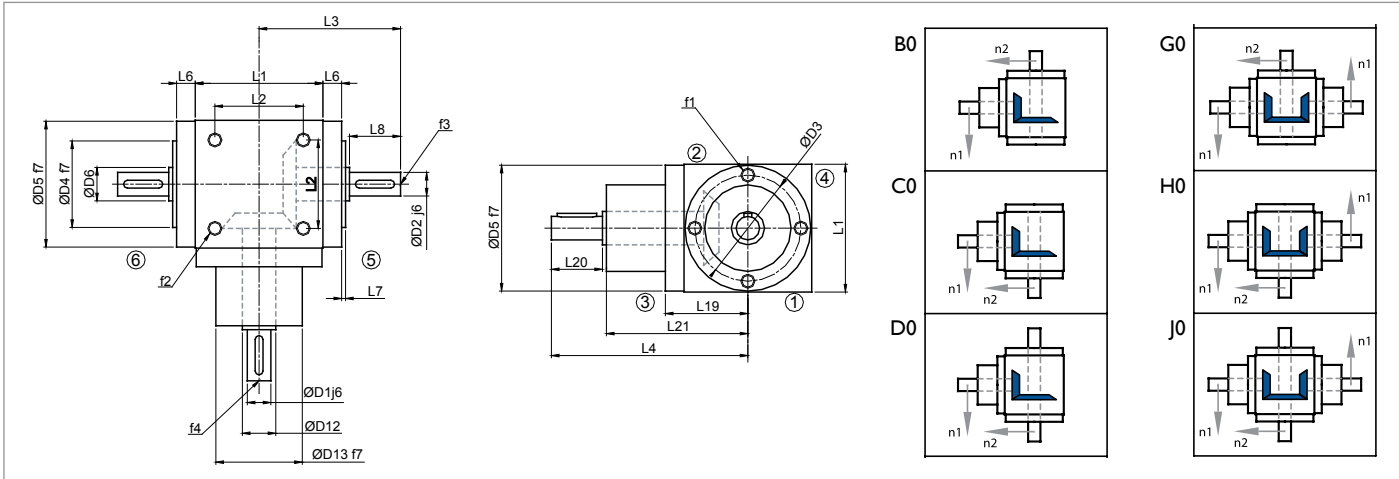

Dimension	Model Description	L-Series										V-Series								
		035		045				065				090				120				
		mm		mm				mm				mm				mm				
Major Dimensions (Applies to all models)	D3	Bolt Circle		29	39				54				75				100			
	D4 f7	Small Pilot Diameter		22	32				44				60				80			
	D5 f7	Pilot Diameter		35	45				64				89				119			
	f2	Housing Thread		M3x8	M4x8				M6x12				M8x14				M10x16			
	L1	Housing Size		35	45				65				90				120			
	L2	Housing Bolt Location		25	30				45				70				100			
	L19	Centerline to Input Pilot		23	30.5				42				55				75			
Input Dimensions that change based on ratio	-	Ratio		1:1	1:1 - 2:1	3:1	4:1	5:1 - 6:1	1:1 - 2:1	3:1	4:1	5:1 - 6:1	1:1 - 2:1	3:1	4:1	5:1 - 6:1	1:1 - 2:1	3:1	4:1	5:1 - 6:1
	D1 j6	Input Shaft Diameter		6	10	10	10	-	12	12	-	-	18	12	12	12	25	20	20	15
	-	Input Shaft Key Width		2	3	3	3	-	4	4	-	-	6	4	4	4	8	6	6	5
	-	Input Shaft Key Length		10	18	18	18	-	20	20	-	-	28	28	28	28	36	36	36	28
	-	Input Shaft Key Height		0.9	1.2	1.2	1.2	-	1.5	1.5	-	-	2.5	1.5	1.5	1.5	3	2.5	2.5	2
	D12	Input Step Diameter		10	15	15	15	-	17	17	-	-	25	20	20	20	30	25	25	20
	D13 f7	Input Hub Pilot Diameter		22	32	32	32	-	44	44	-	-	60	60	60	60	80	80	80	70
	f4	Input Shaft Thread (DIN 332)		M3	M3	M3	M3	-	M4	M4	-	-	M6	M4	M4	M4	M10	M6	M6	M5
	L4	Centerline to End of Input Shaft		59	78	78	78	-	100	100	-	-	122	122	132	132	162	162	172	162
	L20	Input Shaft Length		15	23	23	23	-	26	26	-	-	35	35	35	35	45	45	45	35
L21	Centerline to Input Hub		43	53	53	53	-	72	72	-	-	85	85	95	95	115	115	125	125	
Applies to models B0, C0, D0, G0, H0, J0	D2 j6	Output Shaft Diameter		6	10				12				18				25			
	-	Output Shaft Key Width		2	3				4				6				8			
	-	Output Shaft Key Length		10	18				20				28				36			
	-	Output Shaft Key Height		0.9	1.2				1.5				2.5				3			
	D6	Output Step Diameter		10	15				17				30				35			
	f1	Output Flange Thread		M3x5	M4x8				M6x9.5				M8x10				M10x12			
	f3	Output Shaft Thread (DIN 332)		M3	M3				M4				M6				M10			
	L3	Output Shaft to Centerline		40	57.5				72				95				122			
	L6	Pilot Height		5.5	8				9.5				10				12			
	L7	Small Pilot Height		1.5	2				2				2				3			
Applies to models A0, F0, M0	D2 j6	Output Shaft Diameter		6	10				12				18				25			
	-	Output Shaft Key Width		2	3				4				6				8			
	-	Output Shaft Key Length		10	18				20				28				36			
	-	Output Shaft Key Height		0.9	1.2				1.5				2.5				3			
	D6	Output Step Diameter		10	15				17				30				30			
	D15 f7	Output Hub Pilot Diameter		22	32				44				60				80			
	f1	Output Flange Thread		M3x5	M4x8				M6x9.5				M8x10				M10x15			
	f3	Output Shaft Thread (DIN 332)		M3	M3				M4				M6				M10			
L3	Output Shaft to Centerline		59	78				100				122				162				
L6	Pilot Height		5.5	8				9.5				10				15				
L8	Output Shaft Length		15	23				26				35				45				

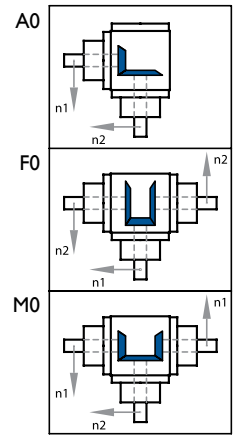
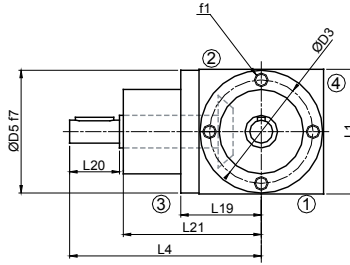
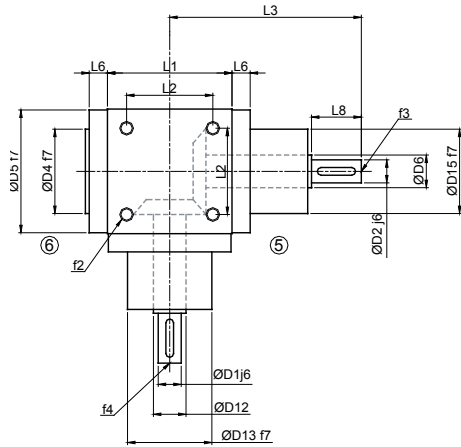

Dimension	V-Series																									
	140				160				200				230				260				350					
mm	mm				mm				mm				mm				mm									
D3	115				135				175				200				230				305*					
D4 f7	90				110				120				150				160				250					
D5 f7	135				159				199				225				255				345					
f2	M10x20				M12x24				M12x24				M16x20				M16x32				M20x26**					
L1	140				160				200				230				260				350					
L2	110				120				160				180				220				285					
L19	85				95				120				135				150				198					
Input Dimensions that change based on ratio	-	1:1 - 2:1	3:1	4:1	5:1 - 6:1	1:1 - 2:1	3:1	4:1	5:1 - 6:1	1:1 - 2:1	3:1	4:1	5:1 - 6:1	1:1 - 2:1	3:1	4:1	5:1 - 6:1	1:1 - 2:1	3:1	4:1	5:1 - 6:1	1:1 - 2:1	3:1	4:1	5:1 - 6:1	
	D1 j6	32	28	24	24	35	28	24	24	42	35	35	28	55	40	40	35	60	45	45	45	80	65	65	55	
	-	10	8	8	8	10	8	8	8	12	10	10	8	16	12	12	10	18	14	14	14	22	18	18	16	
	-	45	45	45	45	50	50	50	50	70	63	63	63	80	70	70	63	100	80	80	80	160	125	125	90	
	-	3	3	3	3	3	3	3	3	3	3	3	3	2.5	3	3	3	4	3.5	3.5	3.5	5	4	4	4	
	D12	40	40	40	40	40	40	40	40	55	40	40	40	30	60	50	50	45	65	65	65	65	90	90	90	72
	D13 f7	90	90	85	85	110	100	100	100	120	120	120	110	150	140	140	140	160	160	160	160	160	250	250	250	250
	f4	M12	M10	M8	M8	M12	M10	M8	M8	M16	M12	M12	M10	M20	M16	M16	M16	M20	M16	M16	M16	M20	M20	M20	M20	
	L4	180	180	195	195	212	212	232	232	273	261	261	261	305	310	310	300	380	360	360	360	360	570	540	540	510
L20	50	50	50	50	60	60	60	60	80	68	68	68	90	80	80	70	110	90	90	90	90	170	140	140	110	
L21	128	128	143	143	150	150	170	170	190	190	190	190	213	228	228	228	265	265	265	265	265	395	395	395	395	
Applies to models B0, C0, D0, G0, H0, J0	D2 j6	32				35				42				55				60				80				
	-	10				10				12				16				18				22				
	-	45				50				70				80				100				160				
	-	3				3				3				4				4				5				
	D6	50				40				55				60				65				90				
	f1	M10x12				M12x15				M12x17				M16x17				M16x20				M20x30				
	f3	M12				M12				M16				M20				M20				M20				
	L3	137				160				203				230				268				410				
	L6	12				15				17				17				20				30				
L7	3				3				3				4				4				20					
L8	50				60				80				90				110				170					
Applies to models A0, F0, M0	D2 j6	32				35				42				55				60				80				
	-	10				10				12				16				18				22				
	-	45				50				70				80				100				160				
	-	3				3				3				4				4				5				
	D6	40				40				55				60				65				90				
	D15 f7	90				110				120				150				160				250				
	f1	M10x15				M12x15				M12x20				M16x20				M16x20				-				
	f3	M12				M12				M16				M20				M20				M20				
	L3	180				212				273				305				380				570				
L6	15				15				20				20				20				23					
L8	50				60				80				90				110				170					



V SERIES & L SERIES

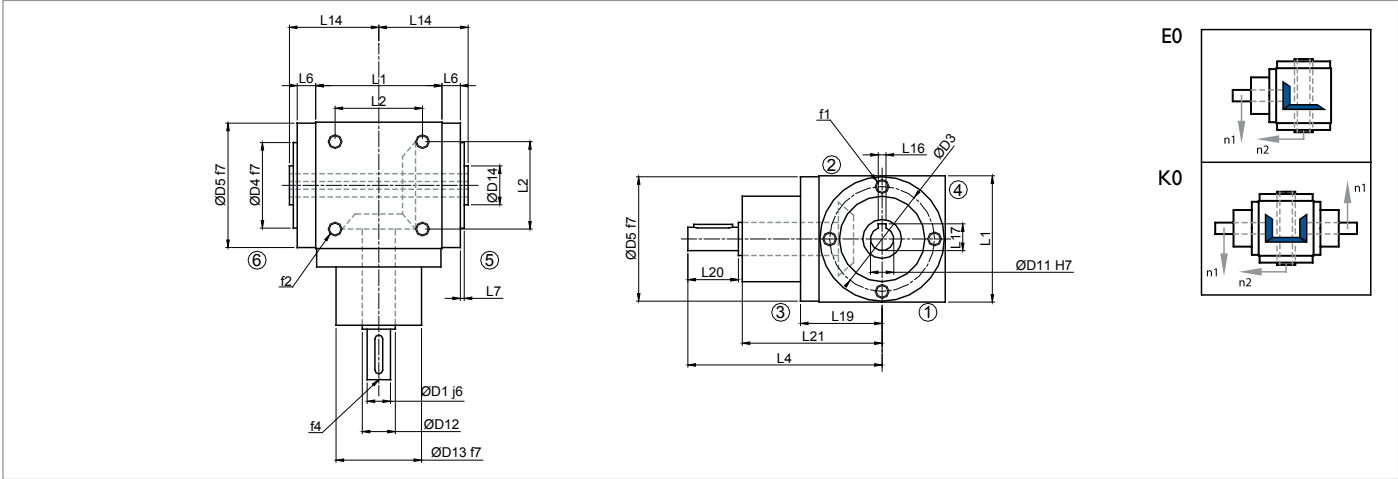

	Dimension	Model Description	L-Series								V-Series								
			035		045			065			090				120				
			mm		mm			mm			mm				mm				
Major Dimensions (Applies to all models)	D3	Bolt Circle	29	39				54			75				100				
	D4 f7	Small Pilot Diameter	22	32				44			60				80				
	D5 f7	Pilot Diameter	35	45				64			89				119				
	f2	Housing Thread	M3x8	M4x8				M6x12			M8x14				M10x16				
	L1	Housing Size	35	45				65			90				120				
	L2	Housing Bolt Location	25	30				45			70				100				
	L19	Centerline to Input Pilot	23	30.5				42			55				75				
Input Dimensions that change based on ratio	-	Ratio	1:1	1:1 - 2:1	3:1	4:1	5:1 - 6:1	1:1 - 2:1	3:1	4:1	5:1 - 6:1	1:1 - 2:1	3:1	4:1	5:1 - 6:1	1:1 - 2:1	3:1	4:1	5:1 - 6:1
	D1 j6	Input Shaft Diameter	6	10	10	10	-	12	12	-	-	18	12	12	12	25	20	20	15
	-	Input Shaft Key Width	2	3	3	3	-	4	4	-	-	6	4	4	4	8	6	6	5
	-	Input Shaft Key Length	10	18	18	18	-	20	20	-	-	28	28	28	28	36	36	36	28
	-	Input Shaft Key Height	0.9	1.2	1.2	1.2	-	1.5	1.5	-	-	2.5	1.5	1.5	1.5	3	2.5	2.5	2
	D12	Input Step Diameter	10	15	15	15	-	17	17	-	-	25	20	20	20	30	25	25	20
	D13 f7	Input Hub Pilot Diameter	22	32	32	32	-	44	44	-	-	60	60	60	60	80	80	80	70
	f4	Input Shaft Thread (DIN 332)	M3	M3	M3	M3	-	M4	M4	-	-	M6	M4	M4	M4	M10	M6	M6	M5
	L4	Centerline to End of Input Shaft	59	78	78	78	-	100	100	-	-	122	122	132	132	162	162	172	162
	L20	Input Shaft Length	15	23	23	23	-	26	26	-	-	35	35	35	35	45	45	45	35
L21	Centerline to Input Hub	43	53	53	53	-	72	72	-	-	85	85	95	95	115	115	125	125	
Applies to models E0 and K0	D11 H7	Hollow Shaft Diameter	6	10				12			18				25				
	D14	Extended Shaft Diameter	10	15				20			30				40				
	f1	Output Flange Thread	M3x5	M4x8				M6x9.5			M8x10				M10x12				
	L6	Pilot Height	5.5	8				9.5			10				12				
	L7	Small Pilot Height	1.5	2				2			2				3				
	L14	Hollow Shaft to Centerline	26.5	34.5				46			62				80				
	L16 JS9	Hollow Shaft Key Width	2	3				4			6				8				
Applies to models E0/HSD, K0/HSD	L17	Hollow Shaft Height with Keyway	7	11.4				13.8			20.8				28.3				
	D7 H6 ***	Smooth Hollow Shaft Diameter 1	-	-				12			18				25				
	D8	Opened up inner Diameter	-	-				13			19				26				
	D9 H7 ****	Smooth Hollow Shaft Diameter 2	-	-				14			20				27				
	D10	Shrink Disc OD	-	-				38			50				60				
	D14	Extended Shaft Diameter	-	-				20			30				40				
	f1	Output Flange Thread	-	-				M6x9.5			M8x10				M10x12				
	L6	Pilot Height	-	-				9.5			10				12				
	L7	Small Pilot Height	-	-				2			2				3				
	L12	Stub Shaft Length	-	-				15			18				22				
	L13	Hollow Bore 1 Depth 1	-	-				25			28				32				
	L14	Hollow Shaft to Centerline	-	-				46			62				80				
	L16	Shrink Disc to Centerline	-	-				63			87				107				

Sold & Served By:



Toll Free Phone: (877) 567-0088

Toll Free Fax: (877) 239-0088

65 www.electromate.com
sales@electromate.com

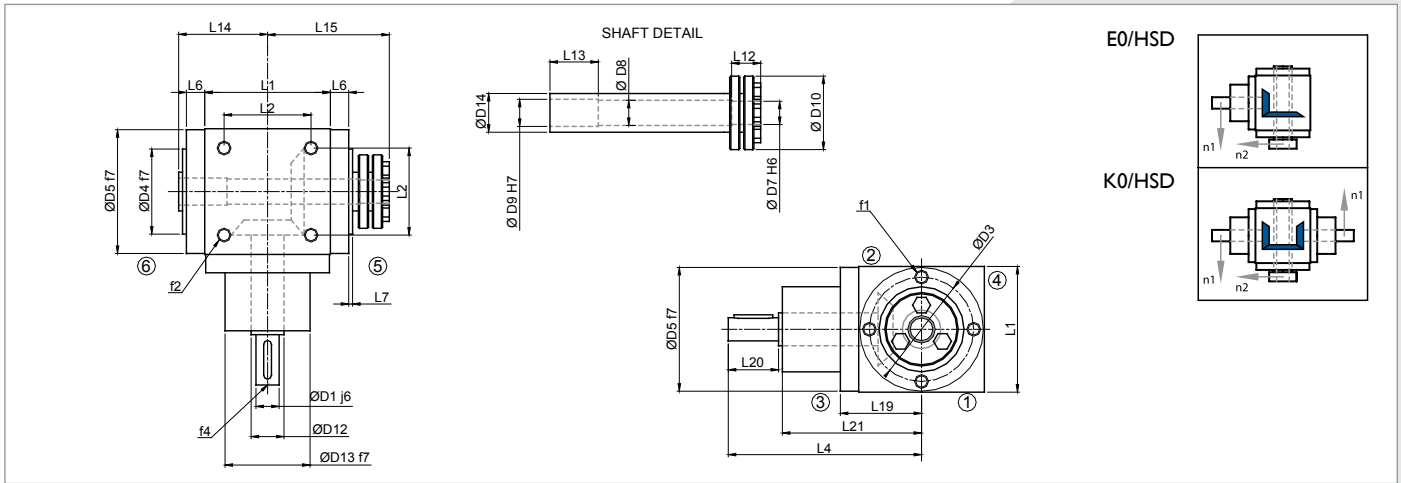

Dimension	V-Series																								
	140		160		200		230		260		350														
	mm		mm		mm		mm		mm		mm														
D3	115		135		175		200		230		305*														
D4 f7	90		110		120		150		160		250														
D5 f7	135		159		199		225		255		345														
f2	M10x20		M12x24		M12x24		M16x20		M16x32		M20x26**														
L1	140		160		200		230		260		350														
L2	110		120		160		180		220		285														
L19	85		95		120		135		150		198														
Input Dimensions that change based on ratio	-	1:1 - 2:1	3:1	4:1	5:1 - 6:1	1:1 - 2:1	3:1	4:1	5:1 - 6:1	1:1 - 2:1	3:1	4:1	5:1 - 6:1	1:1 - 2:1	3:1	4:1	5:1 - 6:1	1:1 - 2:1	3:1	4:1	5:1 - 6:1	1:1 - 2:1	3:1	4:1	5:1 - 6:1
	D1 j6	32	28	24	24	35	28	24	24	42	35	35	28	55	40	40	35	60	45	45	45	80	65	65	55
	-	10	8	8	8	10	8	8	8	12	10	10	8	16	12	12	10	18	14	14	14	22	18	18	16
	-	45	45	45	45	50	50	50	50	70	63	63	63	80	70	70	63	100	80	80	80	160	125	125	90
	-	3	3	3	3	3	3	3	3	3	3	3	3	2.5	3	3	3	4	3.5	3.5	3.5	5	4	4	4
	D12	40	40	40	40	40	40	40	40	55	40	40	30	60	50	50	45	65	65	65	65	90	90	90	72
	D13 f7	90	90	85	85	110	100	100	100	120	120	120	110	150	140	140	140	160	160	160	160	250	250	250	250
	f4	M12	M10	M8	M8	M12	M10	M8	M8	M16	M12	M12	M10	M20	M16	M16	M16	M20	M16	M16	M16	M20	M20	M20	M20
	L4	180	180	195	195	212	212	232	232	273	261	261	261	305	310	310	300	380	360	360	360	570	540	540	510
	L20	50	50	50	50	60	60	60	60	80	68	68	68	90	80	80	70	110	90	90	90	170	140	140	110
L21	128	128	143	143	150	150	170	170	190	190	190	190	213	228	228	228	265	265	265	265	395	395	395	395	
Applies to models E0 and K0	D11 H7	32		35		42		55		60		80													
	D14	50		55		70		80		80		105													
	f1	M10x12		M12x15		M12x17		M16x17		M16x20		M20x30													
	L6	12		15		17		17		20		30													
	L7	3		3		3		4		4		20													
	L14	90		103		125		142.5		160		240													
	L16 JS9	10		10		12		16		18		22													
Applies to models E0/HSD5, K0/HSD5	L17	35.3		38.3		45.3		59.3		64.4		85.4													
	D7 H6***	32		35		42		55		60		80													
	D8	33		36		43		56		61		81													
	D9 H7***	34		37		44		57		62		82													
	D10	80		80		100		138		138		170													
	D14	50		55		70		80		80		105													
	f1	M10x12		M12x15		M12x17		M16x17		M16x20		M20x30													
	L6	12		15		17		17		20		30													
	L7	3		3		3		4		4		20													
	L12	25		25		35		40		40		45													
L13	40		40		55		60		60		65														
L14	90		103		125		142.5		160		240														
L15	122		135		162		182.5		200		293														

Sold & Serviced by
ELECTROMATE
 Toll Free Phone: (977) 587V098
 Toll Free Fax: (977) 587V099
 www.electromate.com
 sales@electromate.com



V SERIES & L SERIES

Ratio	Model Size	L-Series				V-Series					
		035		045		065		090		120	
		1:1		1,2,3,4:1		1, 1.5, 2, 3:1		1, 1.5, 2, 3, 4, 5, 6:1			
Input Speed (RPM)	Output Torque (Nm)	Power (kW)	Output Torque (Nm)	Power (kW)	Output Torque (Nm)	Power (kW)	Output Torque (Nm)	Power (kW)	Output Torque (Nm)	Power (kW)	
1:1	50	4.5	0.025	9	0.05	18	0.1	50	0.28	130	0.72
	250	4.5	0.124	9	0.248	17	0.47	44	1.21	123	3.39
	500	4	0.22	8	0.441	15	0.83	40	2.2	115	6.34
	750	3.6	0.298	7.3	0.603	13	1.07	37	3.06	103	8.51
	1000	3.5	0.386	7	0.772	12	1.32	34	3.75	92	10.14
	1500	3	0.496	6	0.992	11	1.82	32	5.29	82	13.56
	2400	2.4	0.635	4.5	1.19	10	2.65	28	7.41	70	18.52
1.5:1	3000	2	0.661	4	1.323	10	3.31	27	8.93	66	21.82
	50	-	-	-	-	18	0.07	45	0.16	113	0.41
	250	-	-	-	-	17	0.31	40	0.74	108	1.99
	500	-	-	-	-	15	0.55	37	1.36	105	3.85
	750	-	-	-	-	13	0.72	35	1.93	94	5.18
	1000	-	-	-	-	12	0.88	32	2.35	86	6.32
	1500	-	-	-	-	11	1.21	29	3.2	78	8.6
2:1	2400	-	-	-	-	10	1.76	26	4.59	65	11.46
	3000	-	-	-	-	10	2.2	25	5.51	61	13.45
	50	-	-	7	0.019	18	0.05	37	0.1	107	0.29
	250	-	-	6.5	0.09	17	0.23	36	0.5	98	1.35
	500	-	-	6	0.165	15	0.41	34	0.94	92	2.54
	750	-	-	5.7	0.236	13	0.54	32	1.32	86	3.55
	1000	-	-	5.5	0.303	12	0.66	31	1.71	81	4.46
3:1	1500	-	-	5	0.413	11	0.91	27	2.23	73	6.03
	2400	-	-	4.75	0.628	10	1.32	24	3.17	61	8.07
	3000	-	-	4.5	0.744	10	1.65	23	3.8	56	9.26
	50	-	-	5.5	0.01	14	0.03	37	0.07	110	0.21
	250	-	-	5	0.046	13	0.12	36	0.33	95	0.87
	500	-	-	4.5	0.083	13	0.24	34	0.63	90	1.66
	750	-	-	4.2	0.116	12	0.33	32	0.88	87	2.4
4:1	1000	-	-	4	0.147	12	0.44	31	1.14	82	3.01
	1500	-	-	3.5	0.193	11	0.61	27	1.49	74	4.08
	2400	-	-	3.4	0.3	10	0.88	24	2.12	63	5.56
	3000	-	-	3	0.331	10	1.1	23	2.54	58	6.39
	50	-	-	4.5	0.006	-	-	37	0.05	90	0.12
	250	-	-	4.5	0.031	-	-	36	0.25	87	0.6
	500	-	-	4.25	0.059	-	-	34	0.47	84	1.16
5:1	750	-	-	4.2	0.087	-	-	32	0.66	82	1.69
	1000	-	-	4	0.11	-	-	31	0.85	79	2.18
	1500	-	-	3.75	0.155	-	-	27	1.12	74	3.06
	2400	-	-	3.6	0.238	-	-	25	1.65	67	4.43
	3000	-	-	3.5	0.289	-	-	23	1.9	60	4.96
	50	-	-	-	-	-	-	37	0.04	95	0.1
	250	-	-	-	-	-	-	36	0.2	92	0.51
6:1	500	-	-	-	-	-	-	34	0.37	89	0.98
	750	-	-	-	-	-	-	32	0.53	86	1.42
	1000	-	-	-	-	-	-	31	0.68	80	1.76
	1500	-	-	-	-	-	-	27	0.89	72	2.38
	2400	-	-	-	-	-	-	25	1.32	65	3.44
	3000	-	-	-	-	-	-	23	1.52	60	3.97
	50	-	-	-	-	-	-	33	0.03	66	0.06
Standard Backlash	250	-	-	-	-	-	-	30	0.14	71	0.33
	500	-	-	-	-	-	-	29	0.27	69	0.63
	750	-	-	-	-	-	-	29	0.4	68	0.94
	1000	-	-	-	-	-	-	29	0.53	66	1.22
	1500	-	-	-	-	-	-	27	0.74	64	1.75
	2400	-	-	-	-	-	-	25	1.09	57	2.53
	3000	-	-	-	-	-	-	23	1.25	54	2.95
Allowable Radial Loading*	N	Models B0, C0, D0, G0, H0, J0	Contact GAM	Contact GAM	750	1250	1900				
Allowable Axial Loading	N	Models E0, E0/HSD, K0, KO/HSD	Contact GAM	Contact GAM	375	625	950				
Allowable Radial Loading*	N	Models AO, MO, FO, or input shafts	Contact GAM	Contact GAM	Contact GAM	1250	2100				
Allowable Axial Loading	N		Contact GAM	Contact GAM	Contact GAM	625	1050				
Allowable Radial Loading*	N		Contact GAM	Contact GAM	450	700	1150				
Allowable Axial Loading	N		Contact GAM	Contact GAM	225	350	575				
Efficiency at Load	94-98%										
Service Life / Housing Material	10,000 hours / Aluminum					15,000 hours / Cast Iron					
Lubrication	Synthetic Oil					Synthetic Oil					



Toll Free Phone (877) SERV009
 Toll Free Fax (877) SERV099
 www.electromate.com
 sales@electromate.com



V SERIES & L SERIES

Model	L-Series						V-Series					
	Size	035		045		065		090		120		
		1:1	1,2,3,4:1		1, 1.5, 2, 3:1		1, 1.5, 2, 3, 4, 5, 6:1					
Input Speed	Ratios Avail.	Mass Moment of Inertia (kg cm ²)	Weight (g)	Mass Moment of Inertia (kg cm ²)	Weight (g)	Mass Moment of Inertia (kg cm ²)	Weight (kg)	Mass Moment of Inertia (kg cm ²)	Weight (kg)	Mass Moment of Inertia (kg cm ²)	Weight (kg)	
A0	1:1	Contact GAM	230	Contact GAM	510	0.3888	2.3	2.5590	5.1	10.4976	12.6	
	1.5:1	-	-	-	-	0.2406	2.3	1.4822	5.1	4.8409	12.6	
	2:1	-	-	Contact GAM	510	0.1839	2.3	1.1437	5.1	3.6465	12.6	
	3:1	-	-	Contact GAM	510	0.1036	2.3	0.8884	5.1	2.3159	12.6	
	4:1	-	-	Contact GAM	510	-	-	0.3631	5.1	1.2164	12.6	
	5:1	-	-	-	-	-	-	0.3248	5.1	0.7516	12.6	
B0	1:1	Contact GAM	225	Contact GAM	500	0.4231	2.2	3.3543	5.4	15.3022	12.3	
	1.5:1	-	-	-	-	0.3111	2.2	2.1833	5.4	7.4441	12.3	
	2:1	-	-	Contact GAM	500	0.2330	2.2	1.3652	5.4	4.9747	12.3	
	3:1	-	-	Contact GAM	500	0.1001	2.2	1.0465	5.4	3.0123	12.3	
	4:1	-	-	Contact GAM	500	-	-	0.4607	5.4	1.6729	12.3	
	5:1	-	-	-	-	-	-	0.3933	5.4	1.0539	12.3	
C0	1:1	Contact GAM	225	Contact GAM	500	0.4231	2.2	3.3543	5.4	15.3022	12.3	
	1.5:1	-	-	-	-	0.3111	2.2	2.1833	5.4	7.4441	12.3	
	2:1	-	-	Contact GAM	500	0.2330	2.2	1.3652	5.4	4.9747	12.3	
	3:1	-	-	Contact GAM	500	0.1001	2.2	1.0465	5.4	3.0123	12.3	
	4:1	-	-	Contact GAM	500	-	-	0.4607	5.4	1.6729	12.3	
	5:1	-	-	-	-	-	-	0.3933	5.4	1.0539	12.3	
D0	1:1	Contact GAM	260	Contact GAM	530	0.4330	2.3	3.3827	5.5	15.5996	12.5	
	1.5:1	-	-	-	-	0.3155	2.3	2.1959	5.5	7.5762	12.5	
	2:1	-	-	Contact GAM	530	0.2355	2.3	1.3723	5.5	5.0490	12.5	
	3:1	-	-	Contact GAM	530	0.1012	2.3	1.0496	5.5	3.0453	12.5	
	4:1	-	-	Contact GAM	530	-	-	0.4625	5.5	1.6915	12.5	
	5:1	-	-	-	-	-	-	0.3945	5.5	1.0712	12.5	
E0	1:1	Contact GAM	210	Contact GAM	460	0.4754	2.1	3.2507	5	15.1939	12	
	1.5:1	-	-	-	-	0.3634	2.1	2.1372	5	7.3959	12	
	2:1	-	-	Contact GAM	460	0.2853	2.1	1.3393	5	4.9476	12	
	3:1	-	-	Contact GAM	460	0.1524	2.1	1.0350	5	3.0003	12	
	4:1	-	-	Contact GAM	460	-	-	0.4542	5	1.6661	12	
	5:1	-	-	-	-	-	-	0.3892	5	1.0550	12	
E0/HSD	1:1	-	-	-	-	0.6012	2.1	3.9213	5.2	16.9812	12.3	
	1.5:1	-	-	-	-	0.4892	2.1	2.4353	5.2	8.1903	12.3	
	2:1	-	-	-	-	0.4111	2.1	1.5069	5.2	5.3944	12.3	
	3:1	-	-	-	-	0.2782	2.1	1.1095	5.2	3.1988	12.3	
	4:1	-	-	-	-	-	-	0.4961	5.2	1.7778	12.3	
	5:1	-	-	-	-	-	-	0.4160	5.2	1.1265	12.3	
	6:1	-	-	-	-	-	-	0.3660	5.2	0.9449	12.3	

Sold & Serviced By:



Toll Free Phone (877) SERV098
Toll Free Fax (877) SERV099

69 www.electromate.com
sales@electromate.com

Model	V-Series												
		140		160		200		230		260		350	
	Size	1, 1.5, 2, 3, 4, 5, 6:1											
Input Speed	Ratios Avail.	Mass Moment of Inertia (kg cm ²)	Weight (kg)	Mass Moment of Inertia (kg cm ²)	Weight (kg)	Mass Moment of Inertia (kg cm ²)	Weight (kg)	Mass Moment of Inertia (kg cm ²)	Weight (kg)	Mass Moment of Inertia (kg cm ²)	Weight (kg)	Mass Moment of Inertia (kg cm ²)	Weight (kg)
A0	1:1	26.2670	19	29.6710	28.5	121.2522	52	Contact GAM	79	814.2000	85	Contact GAM	269
	1.5:1	11.8569	19	19.6374	28.5	57.6950	52	Contact GAM	79	305.9333	85	Contact GAM	269
	2:1	8.6762	19	12.3589	28.5	36.3095	52	Contact GAM	79	194.2750	85	Contact GAM	269
	3:1	6.4356	19	8.9516	28.5	18.8322	52	Contact GAM	79	85.0833	85	Contact GAM	269
	4:1	1.8432	19	6.5358	28.5	14.2651	52	Contact GAM	79	46.7738	85	Contact GAM	269
	5:1		19	2.2733	28.5	6.1470	52	Contact GAM	79	37.2840	85	Contact GAM	269
	6:1	1.3708	19	2.0901	28.5	5.3881	52	Contact GAM	79	31.8083	85	Contact GAM	269
B0	1:1	36.0994	18.5	31.5527	28	174.7000	48	Contact GAM	76	827.4400	85	Contact GAM	280
	1.5:1	18.7513	18.5	32.0243	28	103.5829	48	Contact GAM	76	168.2622	85	Contact GAM	280
	2:1	12.2785	18.5	20.1006	28	71.6215	48	Contact GAM	76	281.3350	85	Contact GAM	280
	3:1	7.9547	18.5	12.0803	28	34.1931	48	Contact GAM	76	117.2211	85	Contact GAM	280
	4:1	2.6978	18.5	8.4198	28	22.7181	48	Contact GAM	76	66.6638	85	Contact GAM	280
	5:1	2.2113	18.5	3.6887	28	12.8770	48	Contact GAM	76	50.0136	85	Contact GAM	280
	6:1	1.8426	18.5	2.9407	28	10.0616	48	Contact GAM	76	40.7039	85	Contact GAM	280
C0	1:1	36.0994	18.5	31.5527	28	174.7000	48	Contact GAM	76	827.4400	85	Contact GAM	280
	1.5:1	18.7513	18.5	32.0243	28	103.5829	48	Contact GAM	76	168.2622	85	Contact GAM	280
	2:1	12.2785	18.5	20.1006	28	71.6215	48	Contact GAM	76	281.3350	85	Contact GAM	280
	3:1	7.9547	18.5	12.0803	28	34.1931	48	Contact GAM	76	117.2211	85	Contact GAM	280
	4:1	2.6978	18.5	8.4198	28	22.7181	48	Contact GAM	76	66.6638	85	Contact GAM	280
	5:1	2.2113	18.5	3.6887	28	12.8770	48	Contact GAM	76	50.0136	85	Contact GAM	280
	6:1	1.8426	18.5	2.9407	28	10.0616	48	Contact GAM	76	40.7039	85	Contact GAM	280
D0	1:1	37.0815	19	32.5820	28.5	177.8173	50	Contact GAM	78	841.8500	88	Contact GAM	287
	1.5:1	19.1878	19	32.4818	28.5	104.9684	50	Contact GAM	78	383.5556	88	Contact GAM	287
	2:1	12.5241	19	20.3579	28.5	72.4008	50	Contact GAM	78	284.9375	88	Contact GAM	287
	3:1	8.0639	19	12.1947	28.5	34.5395	50	Contact GAM	78	52.2667	88	Contact GAM	287
	4:1	2.7592	19	8.4841	28.5	22.9130	50	Contact GAM	78	67.5644	88	Contact GAM	287
	5:1	2.2506	19	3.7299	28.5	13.0016	50	Contact GAM	78	50.5900	88	Contact GAM	287
	6:1	1.8698	19	2.9693	28.5	10.1482	50	Contact GAM	78	41.1042	88	Contact GAM	287
E0	1:1	32.6630	18	34.3851	27	201.3904	48	Contact GAM	71	828.6900	82	Contact GAM	259
	1.5:1	17.2240	18	33.1416	27	109.0267	48	Contact GAM	71	413.2622	82	Contact GAM	259
	2:1	11.4194	18	20.6658	27	76.4341	48	Contact GAM	71	287.8975	82	Contact GAM	259
	3:1	7.5729	18	12.3315	27	35.2209	48	Contact GAM	71	120.1100	82	Contact GAM	259
	4:1	2.4830	18	8.5611	27	23.3588	48	Contact GAM	71	68.2888	82	Contact GAM	259
	5:1	2.0739	18	3.7791	27	13.8070	48	Contact GAM	71	51.0536	82	Contact GAM	259
	6:1	1.7471	18	3.0048	27	10.7075	48	Contact GAM	71	41.4261	82	Contact GAM	259
E0/HSD	1:1	39.0643	18.7	40.6750	27.5	222.4124	49.3	Contact GAM	72	892.3400	84.9	Contact GAM	264
	1.5:1	20.0691	18.7	35.9371	27.5	118.3707	49.3	Contact GAM	72	441.5511	84.9	Contact GAM	264
	2:1	13.0198	18.7	22.2382	27.5	81.6896	49.3	Contact GAM	72	303.8100	84.9	Contact GAM	264
	3:1	8.2842	18.7	13.0304	27.5	37.5567	49.3	Contact GAM	72	127.1800	84.9	Contact GAM	264
	4:1	2.8831	18.7	8.9542	27.5	24.6726	49.3	Contact GAM	72	72.2656	84.9	Contact GAM	264
	5:1	2.3299	18.7	4.0307	27.5	14.6479	49.3	Contact GAM	72	53.5988	84.9	Contact GAM	264
	6:1	1.9249	18.7	3.1795	27.5	11.2914	49.3	Contact GAM	72	43.1936	84.9	Contact GAM	264

Sold & Serviced By:



Toll Free Phone (877) SERV098
Toll Free Fax (877) SERV099
www.electromate.com
sales@electromate.com



V SERIES & L SERIES

Model	L-Series						V-Series					
	Size	035		045		065		090		120		
		1:1	1,2,3,4:1	1, 1.5, 2, 3:1	1, 1.5, 2, 3, 4, 5, 6:1							
Input Speed	Ratios Avail.	Mass Moment of Inertia (kg cm ²)	Weight (g)	Mass Moment of Inertia (kg cm ²)	Weight (g)	Mass Moment of Inertia (kg cm ²)	Weight (kg)	Mass Moment of Inertia (kg cm ²)	Weight (kg)	Mass Moment of Inertia (kg cm ²)	Weight (kg)	
F0	1:1	Contact GAM	290	Contact GAM	700	0.5832	2.7	3.8385	6.3	15.7464	15	
	1.5:1	-	-	-	-	0.3270	2.7	2.0508	6.3	7.1737	15	
	2:1	-	-	Contact GAM	700	0.2325	2.7	1.4636	6.3	4.9587	15	
	3:1	-	-	Contact GAM	700	0.1252	2.7	1.0305	6.3	2.8991	15	
	4:1	-	-	Contact GAM	700	-	-	0.4430	6.3	1.5444	15	
	5:1	-	-	-	-	-	-	0.3760	6.3	0.9615	15	
	6:1	-	-	-	-	-	-	0.3418	6.3	0.8224	15	
G0	1:1	Contact GAM	285	Contact GAM	660	0.6175	2.6	4.6338	6.9	20.5510	14.7	
	1.5:1	-	-	-	-	0.4653	2.6	3.0968	6.9	9.9522	14.7	
	2:1	-	-	Contact GAM	660	0.3683	2.6	2.1890	6.9	7.3090	14.7	
	3:1	-	-	Contact GAM	660	0.1821	2.6	1.7927	6.9	4.7450	14.7	
	4:1	-	-	Contact GAM	660	-	-	0.7438	6.9	2.5612	14.7	
	5:1	-	-	-	-	-	-	0.6669	6.9	1.6009	14.7	
	6:1	-	-	-	-	-	-	0.6206	6.9	1.4290	14.7	
H0	1:1	Contact GAM	285	Contact GAM	660	0.6175	2.6	4.6338	6.9	20.5510	14.7	
	1.5:1	-	-	-	-	0.4653	2.6	3.0968	6.9	9.9522	14.7	
	2:1	-	-	Contact GAM	660	0.3683	2.6	2.1890	6.9	7.3090	14.7	
	3:1	-	-	Contact GAM	660	0.1821	2.6	1.7927	6.9	4.7450	14.7	
	4:1	-	-	Contact GAM	660	-	-	0.7438	6.9	2.5612	14.7	
	5:1	-	-	-	-	-	-	0.6669	6.9	1.6009	14.7	
	6:1	-	-	-	-	-	-	0.6206	6.9	1.4290	14.7	
J0	1:1	Contact GAM	290	Contact GAM	690	0.6274	2.7	4.6622	7	20.8484	14.9	
	1.5:1	-	-	-	-	0.4697	2.7	3.1094	7	10.0843	14.9	
	2:1	-	-	Contact GAM	690	0.3708	2.7	2.1961	7	7.3833	14.9	
	3:1	-	-	Contact GAM	690	0.1832	2.7	1.7958	7	4.7780	14.9	
	4:1	-	-	Contact GAM	690	-	-	0.7456	7	2.5798	14.9	
	5:1	-	-	-	-	-	-	0.6681	7	1.6128	14.9	
	6:1	-	-	-	-	-	-	0.6217	7	1.4373	14.9	
K0	1:1	Contact GAM	270	Contact GAM	620	0.6698	2.5	4.5302	6.5	20.4427	14.4	
	1.5:1	-	-	-	-	0.5176	2.5	3.0507	6.5	9.9040	14.4	
	2:1	-	-	Contact GAM	620	0.4206	2.5	2.1631	6.5	7.2819	14.4	
	3:1	-	-	Contact GAM	620	0.2344	2.5	1.7812	6.5	4.7330	14.4	
	4:1	-	-	Contact GAM	620	-	-	0.7373	6.5	2.5544	14.4	
	5:1	-	-	-	-	-	-	0.6628	6.5	1.5966	14.4	
	6:1	-	-	-	-	-	-	0.6180	6.5	1.4260	14.4	
K0/HSD	1:1	-	-	-	-	0.7956	2.5	5.2008	6.7	22.2300	14.7	
	1.5:1	-	-	-	-	0.6434	2.5	3.3488	6.7	10.6984	14.7	
	2:1	-	-	-	-	0.5464	2.5	2.3307	6.7	7.7287	14.7	
	3:1	-	-	-	-	0.3602	2.5	1.8557	6.7	4.9315	14.7	
	4:1	-	-	-	-	-	-	0.7792	6.7	2.6661	14.7	
	5:1	-	-	-	-	-	-	0.6896	6.7	1.6681	14.7	
	6:1	-	-	-	-	-	-	0.6367	6.7	1.4757	14.7	
M0	1:1	Contact GAM	290	Contact GAM	700	0.5832	2.7	3.8385	6.3	15.7464	15	
	1.5:1	-	-	-	-	0.3948	2.7	2.3957	6.3	7.3490	15	
	2:1	-	-	Contact GAM	700	0.3192	2.7	1.9675	6.3	5.9808	15	
	3:1	-	-	Contact GAM	700	0.1856	2.7	1.6346	6.3	4.0486	15	
	4:1	-	-	Contact GAM	700	-	-	0.6462	6.3	2.1047	15	
	5:1	-	-	-	-	-	-	0.5984	6.3	1.2932	15	
	6:1	-	-	-	-	-	-	0.5769	6.3	1.2074	15	

Sold & Serviced By:



Toll Free Phone (877) SERV098
Toll Free Fax (877) SERV099

71 www.electromate.com
sales@electromate.com

Model	Size	V-Series											
		140		160		200		230		260		350	
		1, 1.5, 2, 3, 4, 5, 6:1											
Input Speed	Ratios Avail.	Mass Moment of Inertia (kg cm ²)	Weight (kg)	Mass Moment of Inertia (kg cm ²)	Weight (kg)	Mass Moment of Inertia (kg cm ²)	Weight (kg)	Mass Moment of Inertia (kg cm ²)	Weight (kg)	Mass Moment of Inertia (kg cm ²)	Weight (kg)	Mass Moment of Inertia (kg cm ²)	Weight (kg)
F0	1:1	39.4005	23	44.5065	35	181.8783	60	Contact GAM	97	1221.3000	105	Contact GAM	340
	1.5:1	17.6940	23	26.2309	35	84.6400	60	Contact GAM	97	486.8667	105	Contact GAM	340
	2:1	11.9596	23	16.0678	35	51.4661	60	Contact GAM	97	296.0500	105	Contact GAM	340
	3:1	7.8949	23	10.6000	35	25.5685	60	Contact GAM	97	130.3167	105	Contact GAM	340
	4:1	2.6641	23	7.3620	35	18.0543	60	Contact GAM	97	72.2175	105	Contact GAM	340
	5:1	2.0574	23	2.8667	35	8.5721	60	Contact GAM	97	53.5680	105	Contact GAM	340
	6:1	1.7356	23	2.5022	35	7.0721	60	Contact GAM	97	43.1167	105	Contact GAM	340
G0	1:1	49.2329	22.7	46.3882	34.5	235.3261	58	Contact GAM	100	1234.5400	109	Contact GAM	372
	1.5:1	24.7711	22.7	45.0681	34.5	134.3330	58	Contact GAM	100	293.2622	109	Contact GAM	372
	2:1	17.6713	22.7	28.2506	34.5	92.7745	58	Contact GAM	100	373.8350	109	Contact GAM	372
	3:1	12.9310	22.7	19.3835	34.5	46.2891	58	Contact GAM	100	157.0711	109	Contact GAM	372
	4:1	3.7202	22.7	13.9274	34.5	33.1941	58	Contact GAM	100	87.9938	109	Contact GAM	372
	5:1	3.2180	22.7	5.3686	34.5	16.5990	58	Contact GAM	100	71.0136	109	Contact GAM	372
	6:1	2.8486	22.7	4.6187	34.5	13.7656	58	Contact GAM	100	61.2039	109	Contact GAM	372
H0	1:1	49.2329	22.7	46.3882	34.5	235.3261	58	Contact GAM	100	1234.5400	109	Contact GAM	372
	1.5:1	24.7711	22.7	45.0681	34.5	134.3330	58	Contact GAM	100	293.2622	109	Contact GAM	372
	2:1	17.6713	22.7	28.2506	34.5	92.7745	58	Contact GAM	100	373.8350	109	Contact GAM	372
	3:1	12.9310	22.7	19.3835	34.5	46.2891	58	Contact GAM	100	157.0711	109	Contact GAM	372
	4:1	3.7202	22.7	13.9274	34.5	33.1941	58	Contact GAM	100	87.9938	109	Contact GAM	372
	5:1	3.2180	22.7	5.3686	34.5	16.5990	58	Contact GAM	100	71.0136	109	Contact GAM	372
	6:1	2.8486	22.7	4.6187	34.5	13.7656	58	Contact GAM	100	61.2039	109	Contact GAM	372
J0	1:1	50.2150	23.2	47.4175	35	238.4434	60	Contact GAM	102	1248.9500	112	Contact GAM	379
	1.5:1	25.2076	23.2	45.5256	35	135.7185	60	Contact GAM	102	508.5556	112	Contact GAM	379
	2:1	17.9169	23.2	29.0079	35	93.5538	60	Contact GAM	102	377.4375	112	Contact GAM	379
	3:1	13.0402	23.2	19.4979	35	46.6355	60	Contact GAM	102	92.1167	112	Contact GAM	379
	4:1	3.7816	23.2	13.9917	35	33.3890	60	Contact GAM	102	88.8944	112	Contact GAM	379
	5:1	3.2573	23.2	5.4098	35	16.7236	60	Contact GAM	102	71.5900	112	Contact GAM	379
	6:1	2.8758	23.2	4.6473	35	13.8522	60	Contact GAM	102	61.6042	112	Contact GAM	379
K0	1:1	45.7965	22.2	49.2206	34	262.0165	58	Contact GAM	95	1235.7900	106	Contact GAM	351
	1.5:1	23.2438	22.2	46.1854	34	139.7777	58	Contact GAM	95	538.2622	106	Contact GAM	351
	2:1	16.8122	22.2	29.3158	34	97.5871	58	Contact GAM	95	380.3975	106	Contact GAM	351
	3:1	12.5492	22.2	19.6347	34	47.3169	58	Contact GAM	95	159.9600	106	Contact GAM	351
	4:1	3.5054	22.2	14.0687	34	33.8348	58	Contact GAM	95	89.6188	106	Contact GAM	351
	5:1	3.0806	22.2	5.4590	34	17.5290	58	Contact GAM	95	72.0536	106	Contact GAM	351
	6:1	2.7531	22.2	4.6828	34	14.4115	58	Contact GAM	95	61.9261	106	Contact GAM	351
K0/HSD	1:1	52.1978	22.9	55.5105	34.5	283.0385	59.3	Contact GAM	96	1299.4400	108.9	Contact GAM	356
	1.5:1	26.0089	22.9	48.9809	34.5	149.1208	59.3	Contact GAM	96	566.5511	108.9	Contact GAM	356
	2:1	18.4126	22.9	30.8882	34.5	102.8426	59.3	Contact GAM	96	396.3100	108.9	Contact GAM	356
	3:1	13.2605	22.9	20.3336	34.5	49.6527	59.3	Contact GAM	96	167.0300	108.9	Contact GAM	356
	4:1	3.9055	22.9	14.4618	34.5	35.1486	59.3	Contact GAM	96	93.5956	108.9	Contact GAM	356
	5:1	3.3366	22.9	5.7106	34.5	18.3699	59.3	Contact GAM	96	74.5988	108.9	Contact GAM	356
	6:1	2.9309	22.9	4.8575	34.5	14.9954	59.3	Contact GAM	96	63.6936	108.9	Contact GAM	356
M0	1:1	39.4005	23	44.5065	35	181.8783	60	Contact GAM	97	1221.3000	105	Contact GAM	340
	1.5:1	17.8767	23	32.6812	35	88.4451	60	Contact GAM	97	430.9333	105	Contact GAM	340
	2:1	14.0690	23	21.0089	35	57.4625	60	Contact GAM	97	286.7750	105	Contact GAM	340
	3:1	11.4119	23	16.2548	35	30.9282	60	Contact GAM	97	124.9333	105	Contact GAM	340
	4:1	2.8656	23	11.9424	35	24.7411	60	Contact GAM	97	68.1038	105	Contact GAM	340
	5:1	2.5387	23	3.9532	35	9.8690	60	Contact GAM	97	58.2840	105	Contact GAM	340
	6:1	2.3768	23	3.7681	35	9.0921	60	Contact GAM	97	52.3083	105	Contact GAM	340

Sold & Serviced By:



Toll Free Phone (877) SERV098
Toll Free Fax (877) SERV099
www.electromate.com
sales@electromate.com



▶ HIGH PERFORMANCE: VC SERIES

LL size 35 and 45		035	045	065	090	120	140	160	200		
SS = 30% per hour with ambient temperature of -10 to +30 degrees C											
Ratios Available		1:1		1,2,3,4:1		1, 1.5, 2, 3:1		1, 1.5, 2, 3, 4, 5, 6:1			
Nominal Output Torque (T _{2n})	Nm (lb-in)	1:1	4.5 (40)	9 (80)	8 (71)	25 (221)	50 (443)	120 (1062)	180 (1593)	350 (3098)	
		1.5:1	-	-	10 (89)	25 (221)	61 (540)	113 (1000)	185 (1637)	330 (2921)	
		2:1	-	7 (62)	10 (89)	25 (221)	65 (575)	110 (974)	185 (1637)	320 (2832)	
		3:1	-	5.5 (49)	8 (71)	23 (204)	58 (513)	110 (974)	190 (1682)	420 (3717)	
		4:1	-	4.5 (40)	-	23 (204)	60 (531)	105 (929)	180 (1593)	350 (3098)	
		5:1	-	-	-	23 (204)	60 (531)	100 (885)	180 (1593)	300 (2655)	
		6:1	-	-	-	23 (204)	54 (478)	95 (841)	130 (1151)	210 (1859)	
Max Acceleration Output Torque (T _{2B})	Nm (lb-in)	1:1	5.5 (49)	11 (97)	15 (133)	40 (354)	70 (620)	180 (1593)	350 (3098)	700 (6196)	
		1.5:1	-	-	17 (150)	37 (327)	105 (929)	200 (1770)	330 (2921)	690 (6107)	
		2:1	-	8.5 (75)	17 (150)	36 (319)	98 (867)	190 (1682)	320 (2832)	600 (5311)	
		3:1	-	6.5 (58)	15 (133)	36 (319)	95 (841)	177 (1567)	280 (2478)	630 (5576)	
		4:1	-	5.5 (49)	-	36 (319)	87 (770)	162 (1434)	270 (2390)	550 (4868)	
		5:1	-	-	-	36 (319)	92 (814)	143 (1266)	270 (2390)	505 (4470)	
		6:1	-	-	-	31 (274)	71 (628)	122 (1080)	200 (1947)	315 (2788)	
Emergency Output Torque (T _{2NOT})	Nm (lb-in)	1:1	8 (71)	16 (142)	23 (204)	50 (443)	150 (1328)	260 (2301)	480 (4248)	980 (8674)	
		1.5:1	-	-	25 (221)	50 (443)	140 (1239)	280 (2478)	500 (4426)	850 (7523)	
		2:1	-	12.5 (111)	25 (221)	60 (531)	140 (1239)	280 (2478)	550 (4868)	800 (7081)	
		3:1	-	10 (89)	20 (177)	60 (531)	140 (1239)	260 (2301)	400 (3540)	850 (7523)	
		4:1	-	8 (71)	-	60 (531)	140 (1239)	260 (2301)	400 (3540)	800 (7081)	
		5:1	-	-	-	50 (443)	120 (1062)	220 (1947)	380 (3363)	800 (7081)	
		6:1	-	-	-	45 (398)	110 (974)	200 (1947)	350 (3098)	625 (5532)	
Vent Filter may be required (n _v)	RPM	all ratios		-	-	>2200	>1700	>1400	>1200	>900	
				-	-	if housing temperature > 50 degrees C (also depends on duty cycle, ambient temperature, and mounting orientation)					
Max Input Speed (n _{1max})	RPM	1:1	3000	3000	4400	3200	2400	2100	1800	1500	
		1.5:1	-	-	6000	4800	3600	3000	2500	2250	
		2:1	-	3000	6000	6000	4800	4200	3200	3000	
		3:1	-	3000	6000	6000	6000	5000	4500	4000	
		4:1	-	3000	-	6000	6000	6000	5000	4500	
		5:1	-	-	-	6000	6000	6000	6000	5000	
		6:1	-	-	-	6000	6000	6000	6000	6000	
Standard Backlash (j)	arcmin	all ratios		<15	<15	<20	<20	<20	<20	<20	
Reduced Backlash (j)	arcmin	1:1 - 2:1		<8	<8	<6	<6	<6	<6	<6	
		3:1 - 6:1		-	<8	<10	<10	<10	<10	<10	
Allowable Radial Load (F _{rad})	N (lbs)	nominal load @100 rpm output		Contact GAM	750 (169)	1250 (281)	2000 (450)	3000 (675)	5300 (1193)	8000 (1800)	
Allowable Axial Load (F _{axial})	N (lbs)			Contact GAM	375 (84)	625 (141)	1000 (225)	1500 (338)	2650 (596)	4000 (900)	
Weight (m) ³	kg (lbs)			Contact GAM	2 (4)	4.5 (10)	8 (18)	13 (29)	22 (49)	38.5 (85)	
Efficiency at Load		94-98%									
Seal Material		10,000 hours / Aluminum				15,000 hours / Cast Iron					
Lubrication		Synthetic Oil				Synthetic Oil					

▶ VC SERIES & LL SERIES

LL size 35 and 45		035	045	065	090	120	140	160	200	
	Thermal Limit	0.35 kw	0.60 kw	Housing Temperature <= 90 degrees C						
		Continuous Output Torque (T _n)								
Ratio	Input Speed	Nm (lb-in)								
1:1	4000 rpm	-	-	3.6 (32)	8 (71)	-	-	-	-	-
	3000 rpm	1.11 (9.8)	1.9 (16.9)	4.8 (42)	11 (97)	18 (159)	-	-	-	-
	2400 rpm	1.39 (12.3)	2.39 (21.1)	6 (51)	14 (124)	23 (204)	37 (327)	56 (496)	-	-
	1500 rpm	2.23 (19.7)	3.8 (33.8)	8 (71)	17 (150)	37 (327)	60 (531)	90 (797)	157 (1390)	-
1.5:1	4000 rpm	-	-	5.4 (48)	12 (106)	21 (186)	34 (301)	-	-	-
	3000 rpm	-	-	7.2 (64)	17 (150)	28 (248)	45 (398)	68 (602)	-	-
	2400 rpm	-	-	9 (80)	21 (186)	35 (310)	56 (496)	85 (752)	147 (1301)	-
	1500 rpm	-	-	10 (89)	25 (221)	56 (496)	90 (797)	136 (1204)	236 (2089)	-
2:1	4000 rpm	-	-	7.2 (64)	17 (150)	28 (248)	45 (398)	-	-	-
	3000 rpm	-	3.81 (33.7)	9.6 (85)	23 (204)	37 (327)	60 (531)	90 (797)	157 (1390)	-
	2400 rpm	-	4.77 (42)	10 (89)	24 (212)	46 (407)	75 (664)	113 (1000)	196 (1735)	-
	1500 rpm	-	7 (62)	10 (89)	27 (239)	73 (646)	120 (1062)	181 (1602)	314 (2779)	-
3:1	4000 rpm	-	-	7.2 (64)	21 (186)	42 (372)	68 (602)	102 (903)	177 (1567)	-
	3000 rpm	-	5.5 (49)	9.6 (85)	23 (204)	56 (496)	90 (797)	136 (1204)	235 (2080)	-
	2400 rpm	-	5.5 (49)	10 (89)	24 (212)	63 (558)	113 (1000)	170 (1505)	294 (2602)	-
	1500 rpm	-	5.5 (49)	10 (89)	27 (239)	74 (655)	130 (1151)	230 (2036)	472 (4178)	-
4:1	4000 rpm	-	-	-	21 (186)	52 (460)	85 (752)	136 (1204)	235 (2080)	-
	3000 rpm	-	4.5 (39.8)	-	23 (204)	60 (531)	103 (912)	180 (1593)	314 (2779)	-
	2400 rpm	-	4.5 (39.8)	-	25 (221)	67 (593)	111 (982)	200 (1770)	393 (3478)	-
	1500 rpm	-	4.5 (39.8)	-	27 (239)	74 (655)	120 (1062)	220 (1947)	455 (4027)	-
5:1	4000 rpm	-	-	-	21 (186)	52 (460)	90 (797)	160 (1416)	275 (2434)	-
	3000 rpm	-	-	-	23 (204)	60 (531)	100 (885)	180 (1593)	300 (2655)	-
	2400 rpm	-	-	-	25 (221)	65 (575)	105 (929)	198 (1752)	340 (3009)	-
	1500 rpm	-	-	-	27 (239)	72 (637)	115 (1018)	215 (1903)	380 (3363)	-
6:1	4000 rpm	-	-	-	21 (186)	45 (398)	85 (752)	115 (1018)	190 (1682)	-
	3000 rpm	-	-	-	23 (204)	54 (478)	95 (841)	130 (1151)	210 (1859)	-
	2400 rpm	-	-	-	25 (221)	59 (522)	102 (903)	137 (1213)	225 (1991)	-
	1500 rpm	-	-	-	27 (239)	64 (566)	108 (956)	145 (1283)	240 (2124)	-

Sold & Serviced By:



Toll Free Phone (877) SERV098
 Toll Free Fax (877) SERV099
www.electromate.com
sales@electromate.com

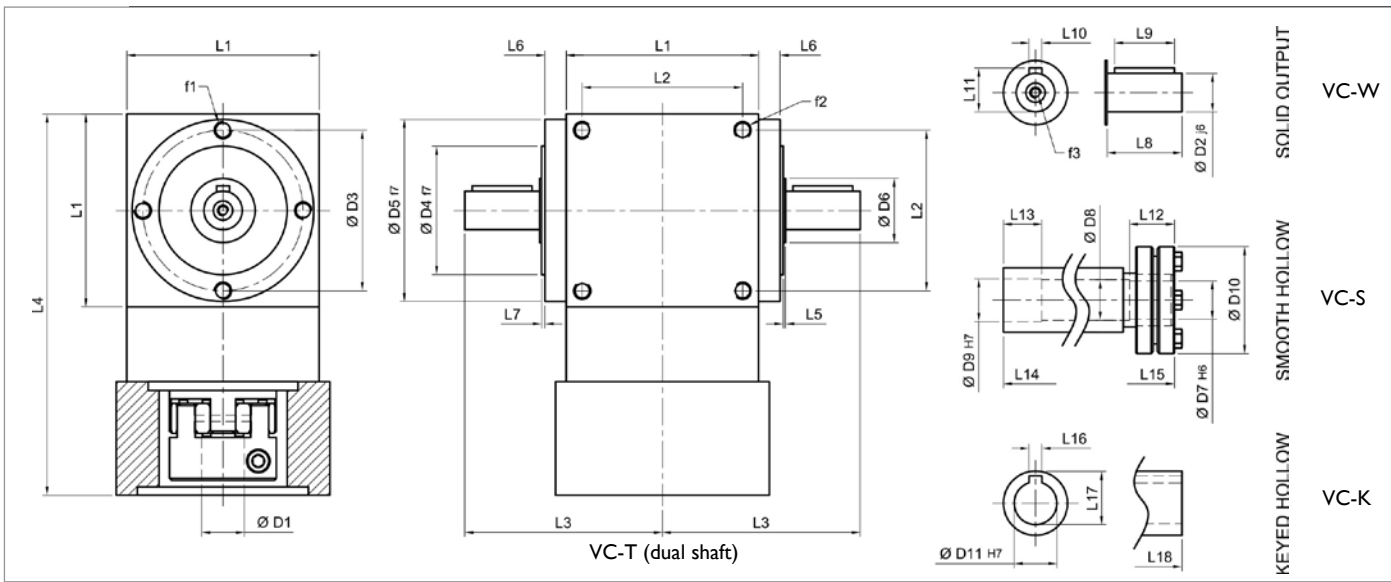

mm (in)		035	045	65	90	120	140	160	200
D1 min	motor shaft diameter	3 (0.118)	3 (0.118)	5 (0.197)	8 (0.315)	13 (0.512)	19 (0.748)	19 (0.748)	24 (0.945)
D1 max		11 (0.433)	11 (0.433)	16 (0.630)	20 (0.787)	28 (1.102)	38.1 (1.500)	38.1 (1.500)	45 (1.772)
D2 j6	output shaft diameter	6 (0.236)	10 (0.393)	12 (0.472)	18 (0.709)	25 (0.984)	32 (1.260)	35 (1.378)	42 (1.654)
	output shaft key size	2 x 2 x 10	3 x 3 x 18	4 x 4 x 20	6 x 6 x 28	8 x 7 x 36	10 x 8 x 45	10 x 8 x 50	12 x 8 x 70
D3	mounting bolt circle 1	29 (1.142)	39 (1.535)	54 (2.126)	75 (2.953)	100 (3.937)	115 (4.528)	135 (5.315)	175 (6.890)
D4 f7	pilot diameter 1	22 (0.866)	32 (1.260)	44 (1.732)	60 (2.362)	80 (3.150)	90 (3.543)	110 (4.331)	120 (4.724)
D5 f7	pilot diameter 2	35 (1.378)	45 (1.772)	64 (2.520)	89 (3.504)	119 (4.685)	135 (5.315)	159 (6.260)	199 (7.835)
D6	shoulder diameter	10 (0.394)	15 (0.591)	17 (0.669)	30 (1.181)	35 (1.378)	50 (1.969)	40 (1.575)	55 (2.165)
D7 H6*	smooth hollow diameter 1	-	-	12 (0.472)	18 (0.709)	25 (0.984)	32 (1.260)	35 (1.378)	42 (1.654)
D8	opened up ID	-	-	13 (0.512)	19 (0.748)	26 (1.024)	33 (1.299)	36 (1.417)	43 (1.693)
D9 H7**	smooth hollow diameter 2	-	-	14 (0.551)	20 (0.787)	27 (1.063)	34 (1.339)	37 (1.457)	44 (1.732)
D10	shrink disc OD	-	-	38 (1.496)	50 (1.969)	60 (2.362)	80 (3.150)	80 (3.150)	100 (3.937)
D11 H7***	keyed hollow diameter	6 (0.236)	10 (0.393)	12 (0.472)	18 (0.709)	25 (0.984)	32 (1.260)	35 (1.378)	42 (1.654)
	hollow shaft key size	2 x 2	3 x 3	4 x 4	6 x 6	8 x 7	10 x 8	10 x 8	12 x 8
L1	housing size	35 (1.378)	45 (1.772)	65 (2.559)	90 (3.543)	120 (4.724)	140 (5.512)	160 (6.299)	200 (7.874)
L2	mounting bolt location 2	25 (0.984)	30 (1.181)	45 (1.772)	70 (2.756)	100 (3.937)	110 (4.331)	120 (4.724)	160 (6.299)
L3	output shaft to centerline	40 (1.575)	57.5 (2.264)	72 (2.835)	95 (3.740)	122 (4.803)	137 (5.394)	160 (6.299)	203 (7.992)
L4****	overall length	Contact GAM		134 (5.276)	185 (7.283)	230 (9.055)	266 (10.47)	295 (11.61)	362 (14.25)
L5	shoulder thickness	0.5 (0.020)	2 (0.079)	2 (0.079)	2 (0.079)	2 (0.079)	2 (0.079)	2 (0.079)	2 (0.079)
L6	output pilot height 2	5.5 (0.217)	8 (0.315)	9.5 (0.374)	10 (0.393)	12 (0.472)	12 (0.472)	15 (0.591)	17 (0.669)
L7	output pilot height 1	1.5 (0.059)	2 (0.079)	2 (0.079)	2 (0.079)	3 (0.118)	3 (0.118)	3 (0.118)	3 (0.118)
L8	output shaft length	15 (0.591)	23 (0.906)	26 (1.024)	35 (1.378)	45 (1.772)	50 (1.969)	60 (2.362)	80 (3.150)
L9	key length	10 (0.393)	18 (0.709)	20 (0.787)	28 (1.102)	36 (1.417)	45 (1.772)	50 (1.969)	70 (2.756)
L10	key width	2 (0.079)	3 (0.118)	4 (0.157)	6 (0.236)	8 (0.315)	10 (0.393)	10 (0.393)	12 (0.472)
L11	shaft height with key	6.8 (0.268)	11.1 (0.437)	13.5 (0.531)	20.5 (0.807)	28 (1.102)	35 (1.378)	38 (1.496)	45 (1.772)
L12	stub shaft length	-	-	17 (0.669)	25 (0.984)	27 (1.063)	32 (1.260)	32 (1.260)	37 (1.457)
L13	diameter 2 length	-	-	15 (0.591)	18 (0.709)	22 (0.866)	25 (0.984)	25 (0.984)	35 (1.378)
L14	hollow shaft to centerline	-	-	46 (1.811)	62 (2.441)	80 (3.150)	90 (3.543)	103 (4.055)	125 (4.921)
L15	shrink disc to centerline	-	-	63 (2.480)	87 (3.425)	107 (4.213)	122 (4.803)	135 (5.315)	162 (6.378)
L16	hollow key width	2 (0.079)	3 (0.118)	4 (0.157)	6 (0.236)	8 (0.315)	10 (0.393)	10 (0.393)	12 (0.472)
L17	hollow height with keyway	7 (0.276)	11.4 (0.449)	13.8 (0.543)	20.8 (0.819)	28.3 (1.114)	35.3 (1.390)	38.3 (1.508)	45.3 (1.783)
L18	hollow shaft to centerline	27 (1.063)	36.5 (1.437)	46 (1.811)	62 (2.441)	80 (3.150)	90 (3.543)	103 (4.055)	125 (4.921)
f1	mounting holes 1	M3 x 5	M4 x 8	M6 x 12	M8 x 14	M10 x 16	M10 x 20	M12 x 24	M12 x 24
f2	mounting holes 2	M3 x 5	M4 x 8	M6 x 9.5	M8 x 10	M10 x 12	M10 x 12	M12 x 15	M12 x 17
f3	shaft thread DIN 332	M3	M3	M4	M6	M10	M12	M12	M16

Sold & Serviced By:
 ELECTROMATE
 12
 15

Toll Free Phone: (877) SERV008 ** Mating shaft should have h6 tolerance *** Mating shaft should have g6 tolerance **** Depending on motor, length may change

Toll Free Fax: (877) SERV099

www.electromate.com

sales@electromate.com

For more information, call us toll-free at 888-GAM-7117 | Visit www.gamweb.com for 2-D and 3-D Drawings

▶ PERFORMANCE: SPIRAL BEVEL SERIES

Mounting Configuration

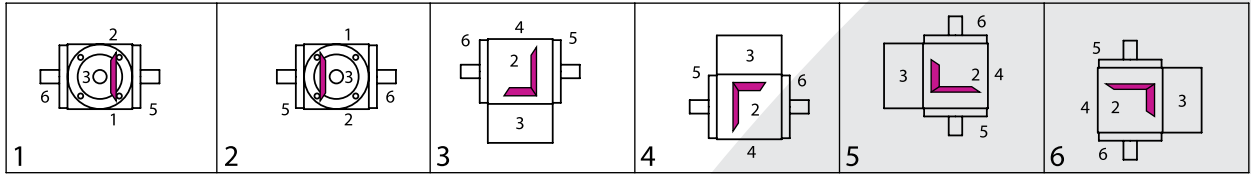

Breather Location

Shaft Output						
	E2	E1	E4	E2	E4	E4
Hollow Output						
	E4	E4	E1 E2	E1	E1 E2	E2 E1
Hollow Output						
	E2	E1	E4	E2	E4	E4
Hollow Output						
	E4	E4	E1 E2	E1	E1 E2	E2 E1

Recommended Output Coupling								
VC Series	035	045	065	090	120	140	160	200
bellows	KG-5 or KM-4	KG-10 or KM-12	KM-12 or 20	KLC-25 or 50	KLC-50 or 125	KLC-125 or KM-170	KM-170,270 or 400	KM-270,400 or 550
elastomer	EKC-5	EKM-8 or 15	EKC-5 or 25	EKC-35 or EKM-45	EKC-80 or 110	EKC-110 or EKM-200	EKM-200,300 or 400	EKM-300,500 or 700

TYPE CODES FOR VC SERIES / LL SERIES

Example: VC - W - 090 - 002 S - [115 - 2AA] - 1-S1-2500-E1-S111

Gearbox Series

VC - Spiral Bevel Series (size 65-200)
LL "mini" Spiral Bevel Series (size 35 & 45)

Gearbox Style

K = Keyed hollow shaft
W = Single output shaft
T = Dual output shaft
S = Smooth hollow output shaft with shrink disc (not available in LL)

Gearbox Size

035, 045, 065, 090, 120, 140, 160, 200

Ratio

1, 1.5, 2, 3, 4, 5, 6

Special Options

Assigned by GAM

Breather Location (if required)

Maximum Input Speed

Duty Cycle
S1 = continuous speed
S5 = cyclic

Mounting Configuration

Motor Mount Kit

Assigned by GAM

Backlash

S = Standard Backlash
R = Reduced Backlash

TYPE CODES FOR V SERIES / L SERIES

Example: V - 090 - 1:1 - C0 - 750-9.1 - E2/S1

Gearbox Series

V - Spiral Bevel
L - "Mini" Spiral Bevel (size 035 and 045)

Gearbox Size

035, 045, 065, 090, 120, 140, 160, 200, 230, 260, 350

Ratio

1, 1.5, 2, 3, 4, 5, 6

Gearbox Model

AO, BO, CO, DO, EO, EO/HSD, FO, GO, HO, JO, KO, KO/HSD, MO

Duty Cycle

S1 Continuous Speed
S5 Cyclic

Breather Location

If applicable

Mounting Configuration

1,2,3,4,5,6

Mounting Side

9 = Standard
Tapped holes on housing sides 1, 2, 4 and on output flanges sides 5, 6

Input Running Speed

0-3000 RPM

Sold & Serviced By
ELECTROMATE

Toll Free Phone (877) SERV098
Toll Free Fax (877) SERV099
www.electromate.com
sales@electromate.com



▶ LINEAR MOUNT PRODUCTS

GAM can.

If you don't see exactly what you need, let us know. We can modify the EPL Series gearboxes to meet your needs. Page 4 provides a list of commonly requested modifications to give you a feel for our capabilities.

GAM Linear Mount Products take the hassle out of mounting your motor or gearbox to a linear ball screw or belt actuator. This unique product offering consists of motor mount kits, inline and right angle gearboxes, as well as couplings. For everything between the motor and actuator, GAM Can!

GAM's EPL-H is an innovative inline gear reducer that features a hollow output design which allows direct connection to linear products. This eliminates the need for any additional couplings or adapters for the most compact and cost effective solution available. Right angle options are available.

EPL-H Series Features

- Low backlash
- Precision gears
- Lightweight
- Lubricated for life
- Mounts to any off the shelf linear belt or ball screw modules
- All adapters and hardware included

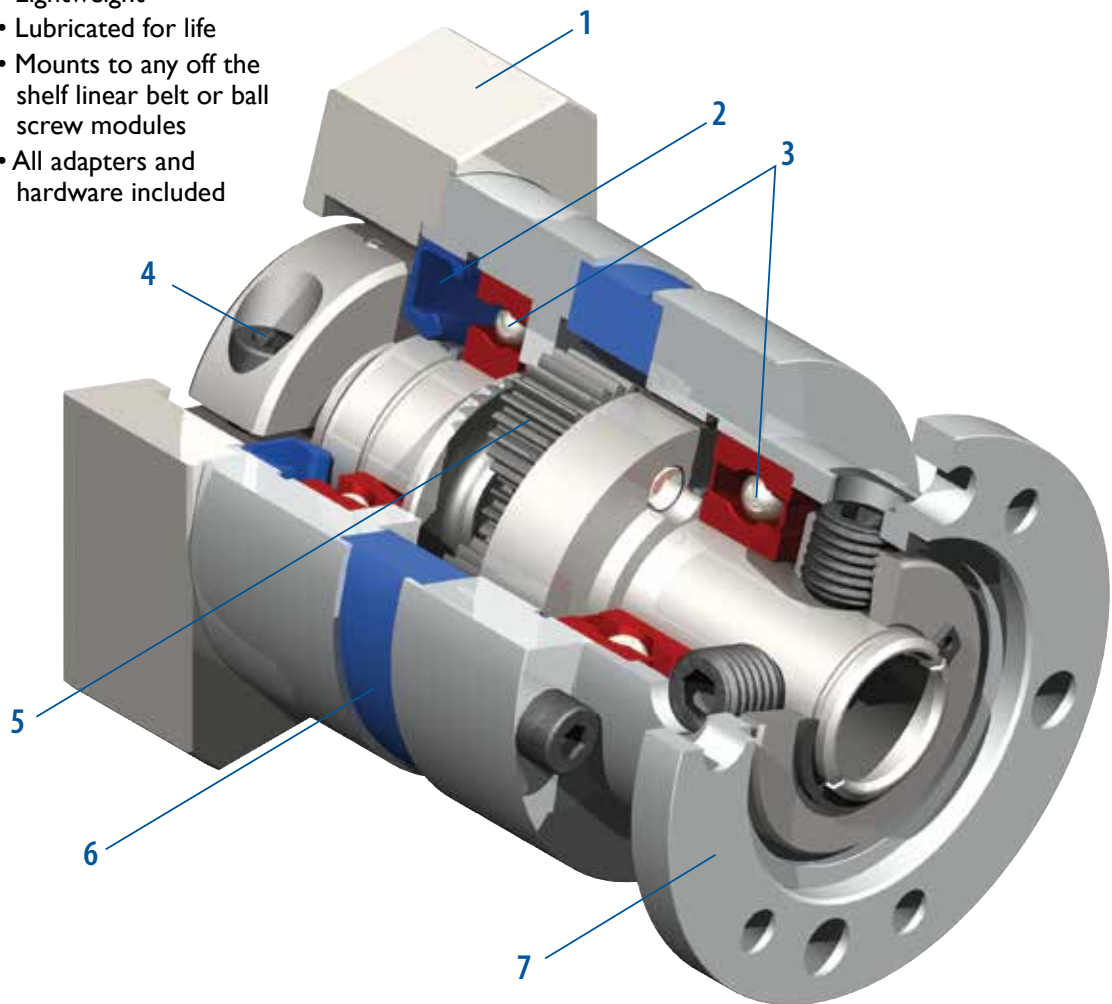

Just tell us what motor and what module you want to mount and GAM will take care of all the engineering.

- 1. Adapter Plate**
(Customized adapter plates for quick and easy motor mounting)
- 2. Seals**
(Protective seals to isolate the gearbox)
- 3. Ball Bearings**
(Single ball bearing in the EPL-H-064; dual ball bearings in all other sizes and styles)
- 4. Input Clamping Element**
- 5. Planet Gears**
(Precision honed gears)
- 6. Ring Gear**
(Ring gear incorporated into housing)
- 7. Output Face**
(Ready to mount to belt or ball screw modules)

Sold & Serviced By:



Toll Free Phone (877) SERV098
Toll Free Fax (877) SERV099

77 www.electromate.com
sales@electromate.com

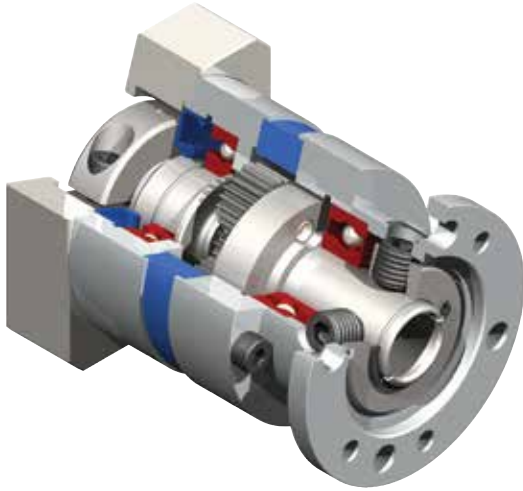

EPL-H Gearboxes

- Our most popular in-line planetary with a unique hollow output and zero-backlash clamping ring
- Quick, simple, and low-cost solution used to mount onto any off-the-shelf linear belt or ball screw modules
- Precision gears
- Ratios up to 1000:1
- Frame sizes from 64 mm to 118 mm
- Same backlash and efficiencies as EPL Series (Specs on pg. 33)

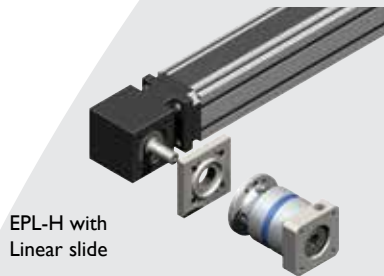

EPL-H with Linear slide

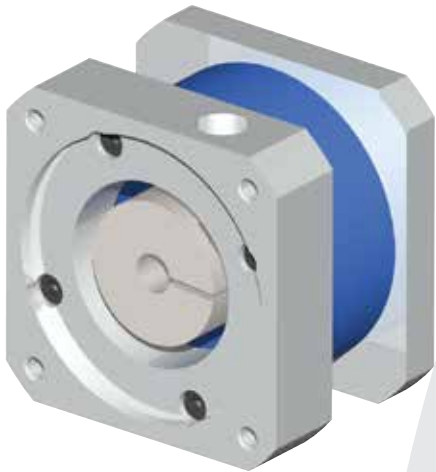

Linear Slide Kit (LSK)

- Customized assembly to mount any motor or gearbox to any linear slide
- In line motor mounting
- Coupling included
- Quick delivery

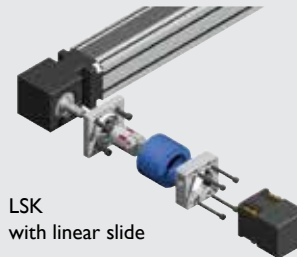

LSK with linear slide

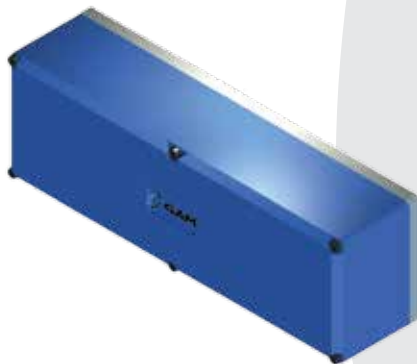

Parallel Mount Kit (PMK)

- Customized assembly to mount any motor or gearbox to any linear ball screw product
- Parallel motor mounting design
- Includes timing pulleys, belt, and hardware.
- Quick delivery

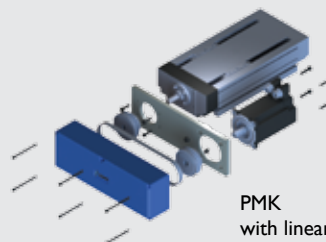

PMK with linear slide

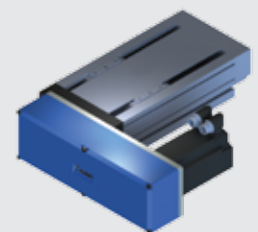

Sold & Serviced By:

 **ELECTROMATE**

Toll Free Phone (877) SERV098

Toll Free Fax (877) SERV099

www.electromate.com

sales@electromate.com



▶ LINEAR MOUNT: LINEAR SLIDE KIT (LSK)

GAM can.

If you don't see exactly what you need, let us know. We can modify the LSK to meet your needs.

Our no-hassle solution for mounting linear slides to motors and gearboxes is our LSK (Linear Slide Kit.) It can be customized to any motor or gearbox and linear slide. A coupling is included – bellows or elastomer. The LSK is readily available and comes complete with mounting hardware. You just need to tighten the bolts.

- A customized mounting solution without the long lead times
- Three sizes
- Quick delivery
- Reasonably priced
- GAM provides all engineering and design for your application
- 2D/3D configurable LSK models now available at www.gamweb.com

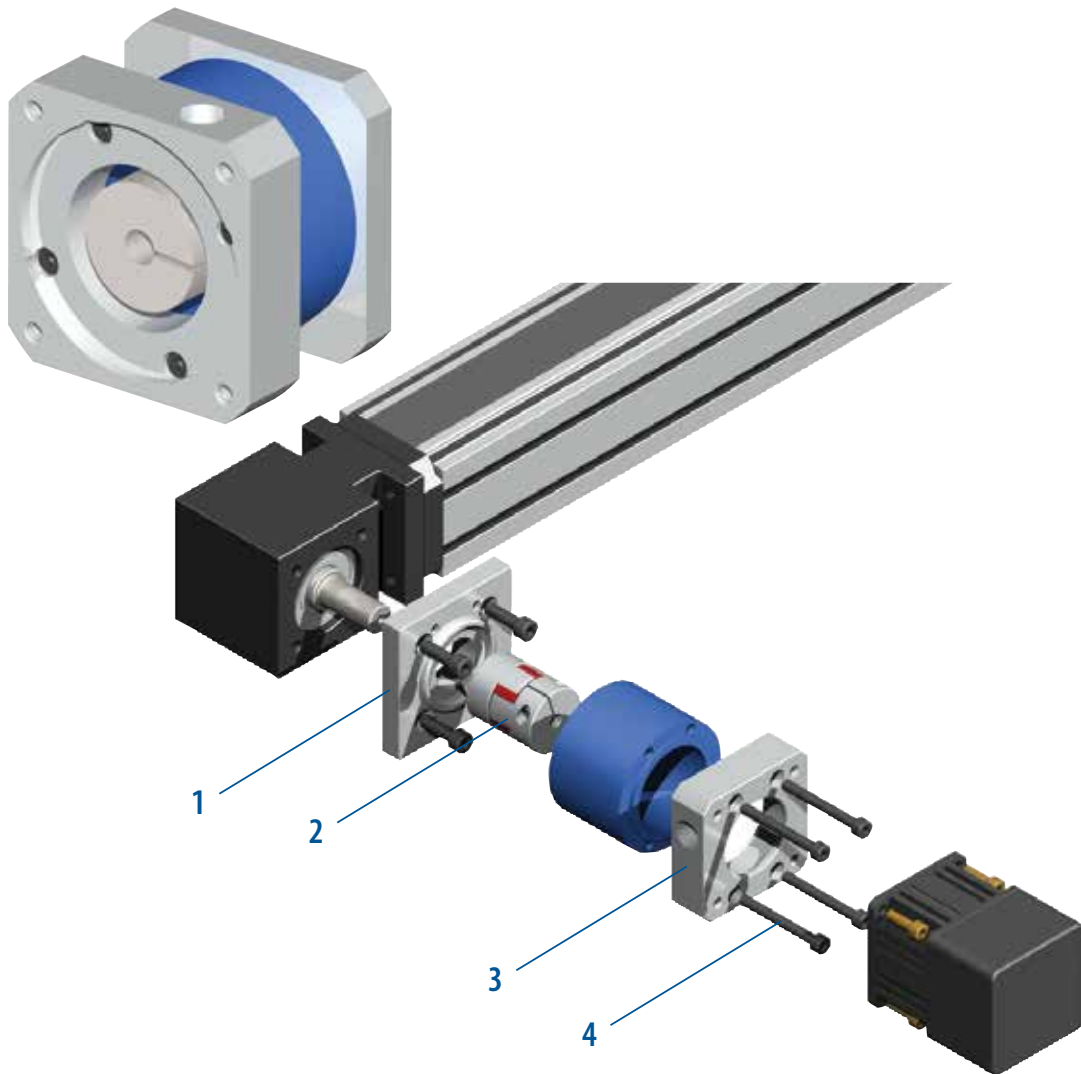

Just tell us what motor and what module you want to mount and GAM will take care of all the engineering.

- 1. Slide Adapter Flange**
(Custom adapter for any linear slide module)
- 2. Coupling**
(Custom machined coupling with or without keyways)
- 3. Motor Adapter Flange**
(Custom adapter for any servo motor)
- 4. Hardware**
(All mounting hardware provided in kit)

Sold & Serviced By:



Toll Free Phone (877) SERV098
Toll Free Fax (877) SERV099

79 www.electromate.com
sales@electromate.com

▶ LINEAR MOUNT: LINEAR SLIDE KIT (LSK)

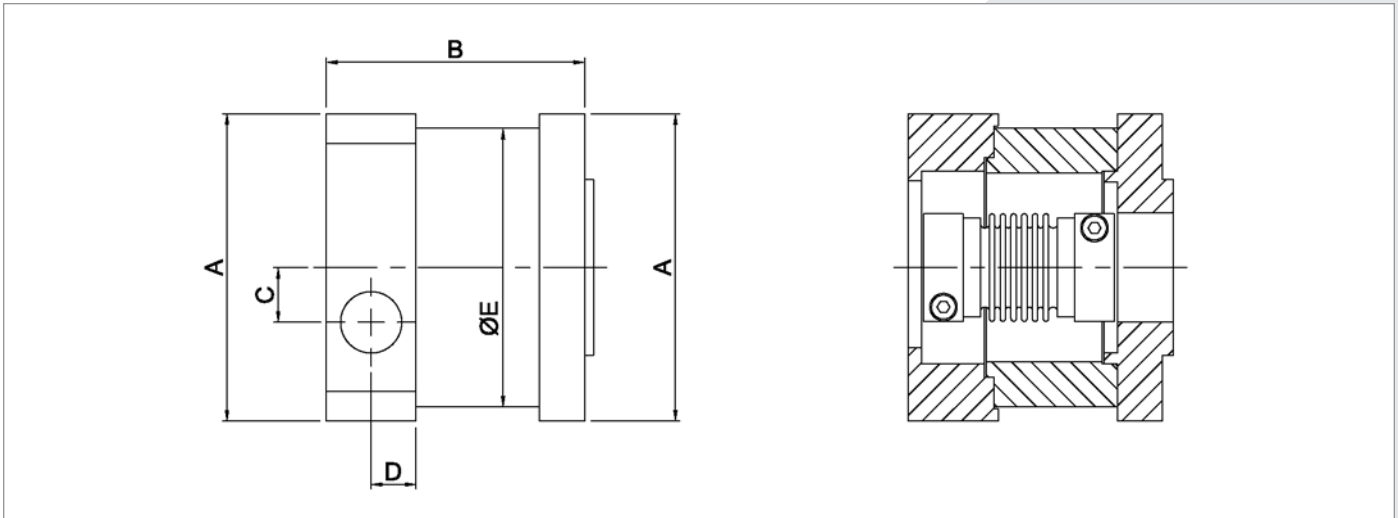

	Coupling Type	Rated Torque Nm (lb-in)	Min Shaft Diameter mm (in)	Max Shaft Diameter mm (in)	Coupling Stiffness 10 ³ Nm/rad (lb-ft/deg)	Coupling Inertia 10 ⁻³ kgm ⁻² (lb-in ⁻²)	Amin mm (in)	Bmin mm (in)	E mm (in)
LSK21	Bellows	4 (35)	3 (0.12)	14* (0.55)	1.8 (23)	0.003 (0.01)	70 (2.75)	62 (2.44)	63.5 (2.50)
LSK22	Bellows	8 (71)	6 (0.24)	19.05* (0.75)	6.5 (84)	0.02 (0.07)	70 (2.75)	70 (2.75)	63.5 (2.50)
LSK23	Elastomer	8 (71)	6 (0.24)	16* (0.63)	0.16 (2.1)	0.01 (0.03)	70 (2.75)	62 (2.44)	63.5 (2.50)
LSK31	Elastomer	15 (133)	9.53 (0.375)	19.05* (0.75)	0.82 (10.6)	0.03 (0.10)	88.9 (3.50)	74 (2.91)	88.9 (3.50)
LSK32	Bellows	25 (221)	9.53 (0.375)	28* (1.10)	12 (154)	0.09 (0.31)	88.9 (3.50)	81 (3.19)	88.9 (3.50)
LSK33	Elastomer	30 (266)	12.7 (0.50)	26* (1.02)	1.4 (18)	0.09 (0.31)	88.9 (3.50)	74 (2.91)	88.9 (3.50)
LSK41	Bellows	50 (443)	15 (0.59)	35* (1.38)	22 (282)	0.22 (0.75)	120 (4.72)	86 (3.39)	114.3 (4.50)
LSK42	Elastomer	60 (531)	15 (0.59)	29* (1.14)	2.1 (27)	0.18 (0.62)	120 (4.72)	86 (3.39)	114.3 (4.50)
LSK43	Bellows	125 (1106)	16 (0.625)	44* (1.73)	44 (565)	0.75 (2.56)	120 (4.72)	95 (3.74)	114.3 (4.50)
LSK44	Elastomer	150 (1328)	22 (0.87)	38.1* (1.50)	3.6 (46)	0.38 (1.30)	120 (4.72)	105 (4.13)	114.3 (4.50)

* An extra adapter may be required for a C-face mounting (motor or gearbox side only)

TYPE CODES FOR LSK SERIES

Example: LSK32K-0001



(N= No Keyways,
K= Keyways)
*Full keyway not available
for max shaft diameter
Contact GAM for other
options



▶ LINEAR MOUNT: PARALLEL MOUNT KIT

Parallel Mount Kit (PMK)

The latest addition to GAM's innovative linear mount product line is the new PMK (Parallel Mount Kit) series. The PMK can help save space and reduce the overall length of an actuator by bringing the motor parallel to the ball screw. Unlike similar products available on the market, the PMK was designed for flexibility enabling you to connect any motor to any linear ball screw actuator.

Features

- 4 frame sizes
- Easily mounted horizontally or vertically
- Torques up to 46Nm (407 in-lbs)

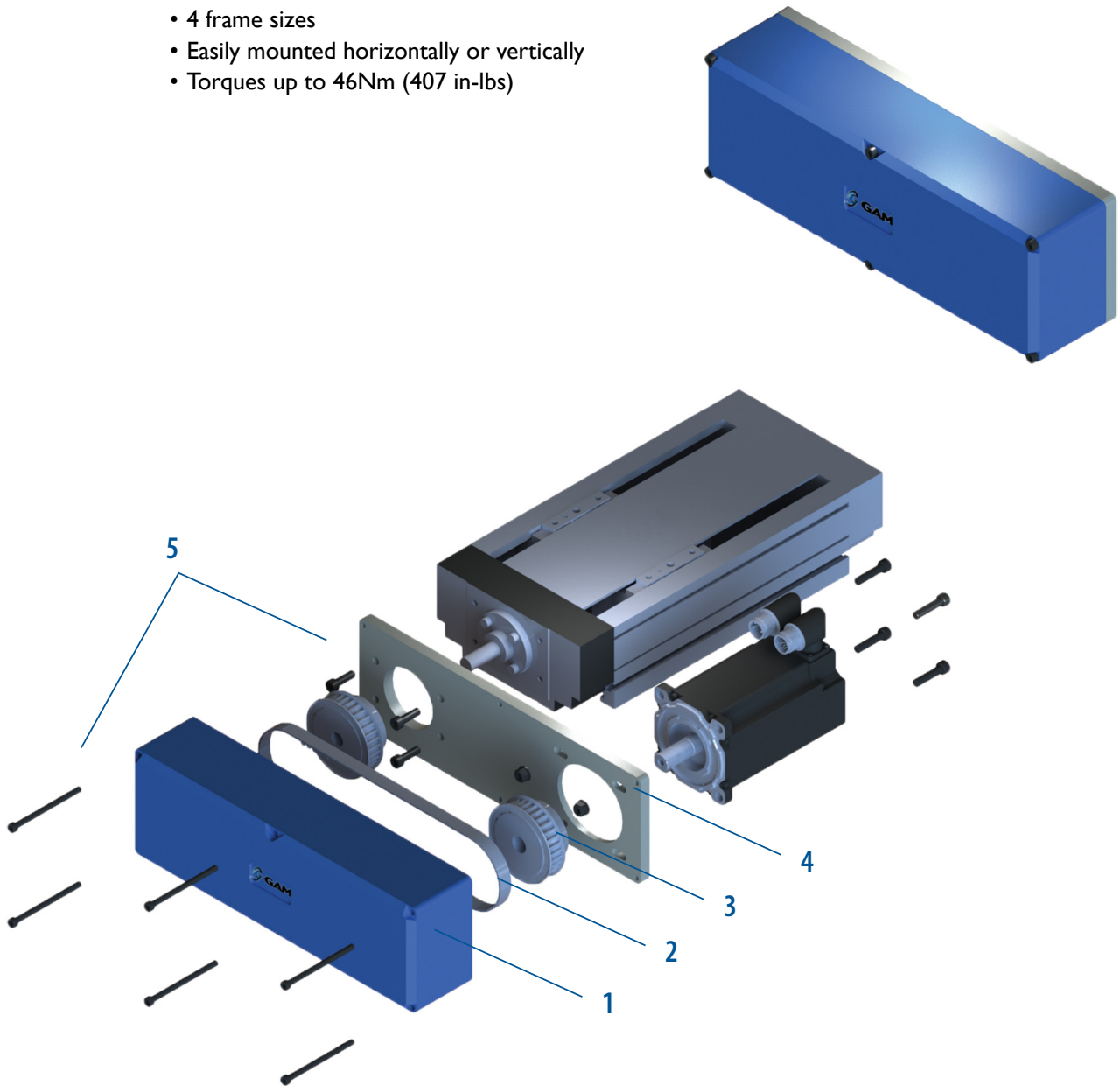

1. Housing

Machined aluminum and anodized

2. Belt

High torque rubber timing belt

3. Pulleys

Low inertia and custom machined

4. Adapter Flange

Designed specifically for any linear ball screw actuator and motor

5. Hardware

All mounting hardware provided in kit

Sold & Serviced By:

ELECTROMATE

Toll Free Phone (877) SERV098

Toll Free Fax (877) SERV099

81 www.electromate.com

sales@electromate.com

▶ LINEAR MOUNT: PARALLEL MOUNT KIT

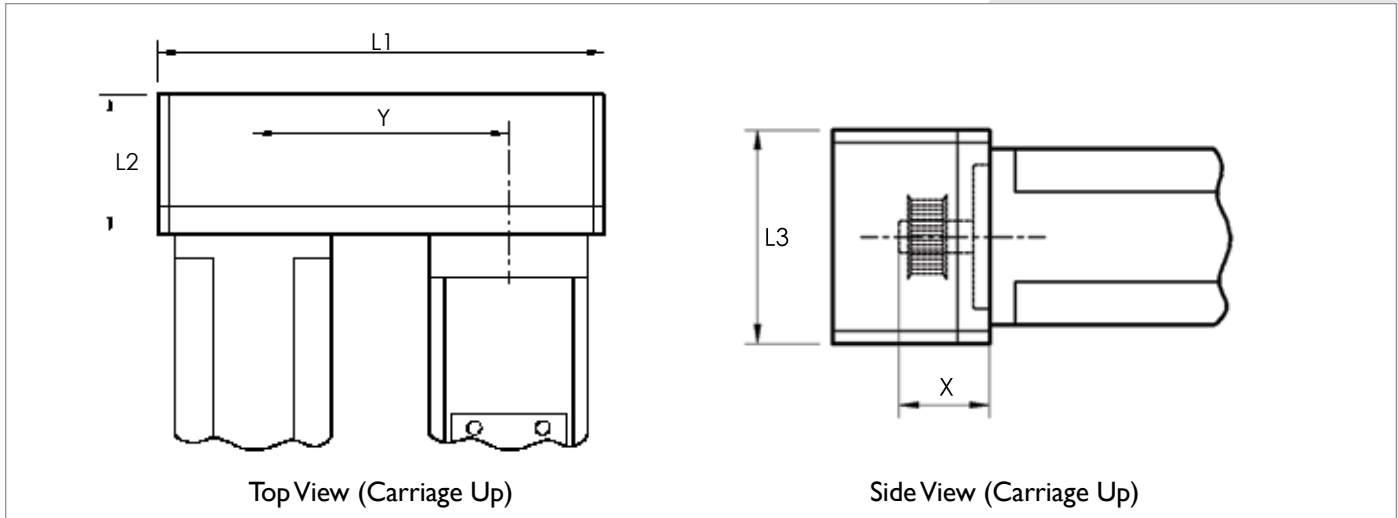

Size	Maximum Output Torque Nm (in-lbs)	Shaft Diameter Range mm (in)		X Maximum Shaft Length mm (in)	Y Center to Center mm (in)	Maximum Motor Bolt Circle mm (in)	L1 mm (in)	L2 mm (in)	L3 mm (in)	Maximum Speed rpm	Pulley Ratio	Recommended Belt Pull** N (lb)
31	2.4 (21.2)	5 (0.197)	14 (0.551)	55 (2.165)	126 (4.961)	75 (2.953)	215 (8.465)	66 (2.598)	76.2 (3.000)	6000	1:1	70 (15.7)
41	7 (62.0)	8 (0.315)	22 (0.866)	70 (2.756)	180 (7.087)	100 (3.937)	290 (11.417)	85 (3.346)	101.6 (4.000)	6000	1:1	332 (74.6)
51	23 (203.6)	10 (0.394)	25.4 (1.000)	80 (3.150)	248 (9.764)	130 (5.118)	390 (15.354)	98 (3.858)	127 (5.000)	6000	1:1	452 (101.6)
61	46 (407.1)	14 (0.551)	38.1 (1.500)	90 (3.543)	280 (11.024)	165 (6.496)	450 (17.716)	111 (4.370)	152.4 (6.000)	6000	1:1	764 (171.8)

Notice

*The PMK adapter plate may not be flush with the bottom of the motor or actuator. If this is an issue, please contact GAM.

**Belt pull required to tension the pulley assembly may exceed radial load capacity of the actuator and must be considered when selecting a PMK. Contact GAM for a bearing support option.

TYPE CODES FOR PMK SERIES

Example: PMK31C-1234

PMK Size

- 3 = 3" Frame
- 4 = 4" Frame
- 5 = 5" Frame
- 6 = 6" Frame

Pulley Torque Option

1

Series Number

Assigned by GAM after Initial Order

Pulley Ratio/Orientation

- A = 1:1 Horizontal
- B = 1:1 Vertical
- C = 1:1 Universal

Mounting Orientation Options

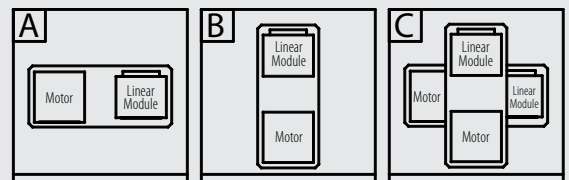

*Universal Mounting Orientation "C" is standard unless unavailable.

*Note: View is normal to input of PMK (Carriage up)

Sold & Serviced By:



Toll Free Phone (877) SERV098

Toll Free Fax (877) SERV099

www.electromate.com

sales@electromate.com



▶ COUPLING OPTIONS FOR EVERY APPLICATION

Bellows Couplings

- High torsional rigidity, low inertia, zero backlash and misalignment compensation
- Can be used at temperatures up to 570°F without any limitations and maintenance free
- Patented Press-Fit method of joining the bellows to the hubs can withstand harsh environments where glued connections cannot
- High speeds: rotational speeds up to 25,000 RPM without additional balancing

MOST POPULAR – Available Same Day



KM Series

- Provides the best balance between coupling stiffness and shaft misalignment compensation
- Aluminum hubs provide low inertia for servo systems
- Radial clamping hub with EASY Clamp system for easy install/uninstall
- Bore range: 3 mm - 85 mm
- Torque range: 0.4 Nm - 1800 Nm



KP Series

- Similar to the KM coupling
- Shorter in length to provide an even higher torsional stiffness, but lower misalignment capability
- Aluminum hubs provide low inertia for servo systems
- Radial clamping hub with EASY Clamp system for easy install/uninstall
- Bore range: 3 mm - 75 mm
- Torque range: 2 Nm - 900 Nm



KLC Series

- Low cost bellows coupling
- Steel hubs with radial clamping: higher inertia
- Short length for high torsional stiffness
- Bore range: 10 mm - 43 mm
- Torque range: 25 Nm - 125 Nm



KG Series

- Similar to the KLC coupling
- Radial clamping hub with EASY Clamp system for easy install/uninstall
- Also available in all stainless steel (KG-VA). Same dimensions as KG.
- Additional sizes
- Bore range: 6 mm - 90 mm
- Torque range: 5 Nm - 1300 Nm



KGGH Series (full info at www.gamweb.com)

- Similar to the KG coupling
- Split hubs allow the coupling to be installed onto shafts that cannot be moved
- Custom lengths
- High stiffness
- Bore range: 6 mm - 85 mm
- Torque range: 20 Nm - 1600 Nm



KSD Series (full info at www.gamweb.com)

- High clamping forces and high torque
- Maximum misalignment with short length
- Self-centering conical bushings
- Bore range: 6 mm - 102 mm
- Torque range: 10 Nm - 2500 Nm



KHS Series (full info at www.gamweb.com)

- High speeds up to 25,000 rpm
- Very low inertia
- High stiffness
- Bore range: 6 mm - 60 mm
- Torque range: 15 Nm - 600 Nm



KR Series (full info at www.gamweb.com)

- Unique bellows design yields the highest performance in stiffness, for the most demanding servo applications.
- Radial clamping hub with EASY Clamp system for easy install/uninstall
- Bore range: 14 mm - 89 mm
- Torque range: 25 Nm - 1500 Nm



KSS Series (full info at www.gamweb.com)

- Similar to the KR coupling
- Self-centering conical bushings for high clamping forces
- Short length and high torque
- Bore range: 10 mm - 102 mm
- Torque range: 25 Nm - 2500 Nm



KPP Series (full info at www.gamweb.com)

- Plug-in design with high stiffness
- EASY Clamp system for easy install/uninstall
- Short length
- Bore range: 6 mm - 70 mm
- Torque range: 10 Nm - 600 Nm



KPS Series (full info at www.gamweb.com)

- Expandable split shaft design
- EASY Clamp system for easy install/uninstall
- For hollow bore applications
- Bore range: 3 mm - 70 mm
- Torque range: 2 Nm - 600 Nm



WDS Series

- Drive shaft coupling with split hubs
- Lengths up to 20 feet
- High speeds and low inertia
- Bore range: 6 mm - 85 mm
- Torque range: 15 Nm - 1600 Nm

Sold & Serviced By:



Toll Free Phone (877) SERV098
Toll Free Fax (877) SERV099

83 www.electromate.com
sales@electromate.com

Elastomer Couplings

- The use of elastomer spiders with shore hardness ratings from 92 Sh A, 98 A, to 72 D permit dampening of vibration caused by system resonance
- An affordable alternative if high stiffness is not critical
- The involute shaped teeth of the elastomer spider and jaws are preloaded and will not loosen over time. Ensures zero backlash and allows for easy plug-in assembly

MOST POPULAR – Available Same Day



EKC Series

- Low cost elastomer spider coupling for motion control applications
- Zero backlash over the life of the product
- Easy to mount radial clamping hubs
- Bore range: 5 mm - 45 mm
- Torque range: 5 Nm - 110 Nm



EKZ Series (full info at www.gamweb.com)

- Drive shaft coupling with radial clamping hubs
- Excellent dampening capabilities
- Lengths up to 3m
- Bore range: 10 mm - 70 mm
- Torque range: 20 Nm - 700 Nm



EKM Series

- Excellent dampening capabilities
- Easy to mount radial clamping hubs
- Same day delivery available
- Bore range: 3 mm - 70 mm
- Torque range: 2 Nm - 1000 Nm



ESM-A Series (full info at www.gamweb.com)

- Excellent dampening capabilities
- High speeds
- Conical clamping hubs
- Bore range: 6 mm - 60 mm
- Torque range: 10 Nm - 1000 Nm



EDC Series

- Low cost elastomer drive shaft coupling
- Customized lengths up to 20 feet
- Quick standard delivery
- Bore range: 8mm - 45mm
- Torque Range: 25 - 110Nm

Protect Your Investment from Crashes and Jams with Safety Couplings

- Low inertia; compensation of misalignment
- Zero backlash: high torsional stiffness
- Patented Press-Fit method joins bellows to the hubs to withstand harsh environments
- Automatic re-engagement: occurs every 360°
- Integrated bearing support: eliminates the need for support inside the pulley and enables compact size
- Degressive cup spring characteristic: immediate torque drop-off



SKB-KP Series

- Single point 360° re-engagement
- Adjustable torque
- Maximum misalignment and high stiffness
- Bore range: 6 mm - 100 mm
- Torque range: 2 Nm - 3000 Nm



SKY-KS Series (full info at www.gamweb.com)

- Single point 360° re-engagement
- Adjustable torque
- Self-centering conical bushings
- Bore range: 5 mm - 70 mm
- Torque range: 2 Nm - 3000 Nm



SKB-EK Series

- Single point 360° re-engagement
- Adjustable torque
- Excellent dampening capabilities
- Bore range: 6 mm - 100 mm
- Torque range: 2 Nm - 1000 Nm



SKY-ES Series (full info at www.gamweb.com)

- Single point 360° re-engagement
- Adjustable torque with self-centering conical hubs
- Excellent dampening capabilities
- Bore range: 5 mm - 70 mm
- Torque range: 2 Nm - 1000 Nm



SKB Series

- Radial clamping hub connection to the shaft
- Single point 360 degree re-engagement
- Integrated ball bearing for the highest true running accuracy
- Adjustable torque
- Very high clamping forces and torque range
- Bore range: 6 mm - 100 mm
- Torque range: 2 Nm - 3000 Nm

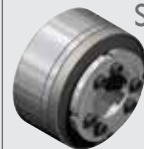

SKG Series

- Single point 360° re-engagement
- Integrated bearing to support pulleys & sprockets
- Adjustable torque with self-centering hub
- Bore range: 12 mm - 44 mm
- Torque range: 2 Nm - 550 Nm



SKX-L Series (full info at www.gamweb.com)

- Single point 360° re-engagement
- Adjustable torque
- Bore range: 7 mm - 58 mm
- Torque range: 2 Nm - 800 Nm
- Our most economical in-direct drive safety coupling

Direct Drive Safety Couplings

Indirect Drive Safety Couplings

Sold & Serviced By:



Toll Free Phone (877) SERV098
Toll Free Fax (877) SERV099
www.electromate.com
sales@electromate.com



▶ COMPONENT OVERVIEW

Hubs:

Aluminum Radial Clamping Hub (also available in steel and stainless steel)



- High tensile strength, low weight aerospace aluminum provides very low inertia for better system performance.
- New EASY Clamp System prevents damage to hubs for easy shaft mounting and dismounting while compensating for tolerance differences between shaft and hub. (Available on select couplings.)
- Balancing Plug is positioned at a precise angle in the hub for balanced, high speed performance.
- Precision machined involutes (not a die cast).
- Zero backlash torque transmission is guaranteed.
- Only one clamping screw allows for fast installation.



Steel Conical Bushings (also available in aluminum for high torque, high speed applications up to 25,000 rpm)

- High clamping forces to insure safe transmission of torque and backlash free connection.
- Additional draw-off holes provide easy hub removal.
- Unique hub design offers shortest coupling length.
- Precision machined aluminum conical clamping ring insures a high speed balanced coupling up to 25,000 rpm at very high torque ranges.



Special Hub Designs

- Flange mounted versions allow custom mounting configurations directly to the machine.
- All metal pluggable versions offer easy mounting in high temperature applications up to 300°C (572°F).
- Expanding cone clamping hub is ideal for hollow shaft assembly.

Sold & Serviced By:

 **ELECTROMATE**

Toll Free Phone (877) SERV098

Toll Free Fax (877) SERV099

85 www.electromate.com
sales@electromate.com

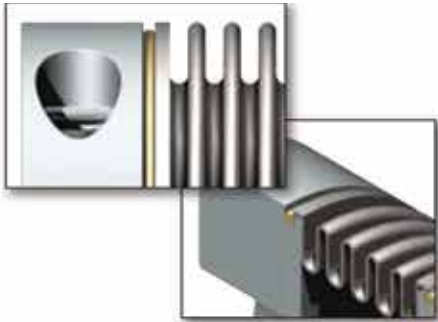

Connection Methods:

Brass Wire Press-Fit Connection

- Mechanically formed between hub and multi-layered bellow for a strong zero backlash connection.
- No glue connection insures connection in high temperature, chemical sensitive applications.

Welded Connection

- Micro plasma weld connection offers excellent weld consistency and even heat distribution resulting in high quality welds for a long lasting connection between hub and bellow.
- Ideal for high temperature applications where steel or stainless steel is required.



Torque Transmission Elements:

Bellows

- Guarantees a zero backlash torque transmission with extremely high torsional stiffness while maintaining flexibility for compensation of misalignment.
- Low mass moment of inertia for increased system performance.
- Maintenance free up to temperatures of 300°C (572°F).
- Depending upon torsional stiffness requirements, lateral spring rates and lengths, standard bellows are available in 2, 4 and 6 corrugations. For longer lengths, custom manufacturing is available.



Elastomers

- Elastomers vary in hardness values from 98 Shore A (red) for maximum dampening capabilities to 72 Shore D (white) where higher stiffness is required.
- Excellent electrical insulator to prevent the transfer of electrical fields.
- Involute shaped teeth provide easy plug-in assembly for long and durable life.



Torque Tubes

- Available in aluminum, steel or stainless depending upon torque and length requirements.
- The different materials can accommodate different stiffness requirements at various lengths.

Sold & Serviced By:

 **ELECTROMATE**

Toll Free Phone (877) SERV098

Toll Free Fax (877) SERV099

www.electromate.com

sales@electromate.com



▶ KM SERIES BELLOWS COUPLINGS



Major Features

- Maximum flexibility in the angular, axial and lateral directions and high torsional stiffness.
- With EASY Clamp System for easy install and un-install.
- Same day delivery available

Material

- Stainless steel bellow; aluminum hubs

Technical data/Dimensions

Size KM	Nominal Torque	Moment of Inertia	Torsion Resistance	Max. Lateral Misalignment	Mass	Screw Size	Torque to Tighten Screws	Outer Diameter	Length	Bore Range	
	Nm (lb-in)	10 ⁻³ kgm ² (lb-in ²)	Nm/arcmin (lb-ft/Deg)	mm (inch)	kg (lbs)		Nm (lb-in)	mm (inch)	mm (inch)	mm (inch)	mm (inch)
KM-0.4	0.4	0.0003	0.05	0.2	0.01	M2.5	1	16.5	30	3	6.35
	(4)	(0.001)	(2)	(0.008)	(0.02)		(9)	(0.650)	(1.181)	(0.118)	(0.250)
KM-0.9	0.9	0.0004	0.09	0.2	0.01	M2.5	1	16.5	31.5	3	6.35
	(8)	(0.001)	(4)	(0.008)	(0.02)		(9)	(0.650)	(1.240)	(0.118)	(0.250)
KM-2	2	0.003	0.23	0.2	0.03	M3	2	24.5/27.5	42	3	10/14
	(18)	(0.01)	(10)	(0.008)	(0.07)		(18)	(0.965)/(1.083)	(1.654)	(0.118)	(0.394)/(0.551)
KM-4	4	0.003	0.46	0.2	0.04	M3	2	24.5/27.5	43.5	5	10/14
	(35)	(0.01)	(20)	(0.008)	(0.09)		(18)	(0.965)/(1.083)	(1.713)	(0.197)	(0.394)/(0.551)
KM-7	7	0.014	1.1	0.25	0.08	M4	4	34	57	6	17
	(62)	(0.05)	(49)	(0.010)	(0.18)		(35)	(1.339)	(2.244)	(0.236)	(0.669)
KM-8	8	0.026	1.35	0.3	0.13	M5	7	39.5/44.5	60	6	19/24
	(71)	(0.09)	(60)	(0.012)	(0.29)		(62)	(1.555)/(1.752)	(2.362)	(0.236)	(0.748)/(0.945)
KM-12	12	0.03	2.05	0.25	0.14	M5	7	39.5/44.5	62	6	19/24
	(106)	(0.10)	(91)	(0.010)	(0.31)		(62)	(1.555)/(1.752)	(2.441)	(0.236)	(0.748)/(0.945)
KM-20	20	0.14	5.2	0.25	0.3	M6	14	56	70	9	30
	(177)	(0.48)	(230)	(0.010)	(0.66)		(124)	(2.205)	(2.756)	(0.354)	(1.181)
KM-35	35	0.14	5.8	0.25	0.3	M6	14	56	70	14	30
	(310)	(0.48)	(257)	(0.010)	(0.66)		(124)	(2.205)	(2.756)	(0.551)	(1.181)
KM-60	60	0.29	8.7	0.3	0.5	M8	35	66	77	15	34
	(531)	(0.99)	(385)	(0.012)	(1.10)		(310)	(2.598)	(3.031)	(0.591)	(1.339)
KM-80	80	0.79	14	0.3	0.8	M10	65	82	90	17	43
	(708)	(2.70)	(620)	(0.012)	(1.76)		(575)	(3.228)	(3.543)	(0.669)	(1.693)
KM-170	170	0.83	17	0.3	0.8	M10	65	82	92	22	43
	(1505)	(2.84)	(753)	(0.012)	(1.76)		(575)	(3.228)	(3.622)	(0.866)	(1.693)
KM-270	270	2.2	32	0.3	1.4	M12	115	101	100	27	55
	(2390)	(7.52)	(1417)	(0.012)	(3.09)		(1018)	(3.976)	(3.937)	(1.063)	(2.165)
KM-400	400	2.4	47	0.3	1.5	M12	115	101	106	32	55
	(3540)	(8.20)	(2081)	(0.012)	(3.31)		(1018)	(3.976)	(4.173)	(1.260)	(2.165)
KM-600	600	4.7	67	0.3	2.2	M14	200	122	116	35	70
	(5310)	(16.06)	(2967)	(0.012)	(4.85)		(1770)	(4.803)	(4.567)	(1.378)	(2.756)
KM-900	900	9	105	0.3	3.3	M14	200	133	143	40	75
	(7966)	(30.75)	(4649)	(0.012)	(7.28)		(1770)	(5.236)	(5.630)	(1.575)	(2.953)
KM-1300	1300	14	170	0.3	4.2	M16	290	157	145	60	85
	(11506)	(47.84)	(7528)	(0.012)	(9.26)		(2567)	(6.181)	(5.709)	(2.362)	(3.346)
KM-1800	1800	15	260	0.3	4.5	M16	290	157	145	65	85
	(15911)	(51.26)	(11513)	(0.012)	(9.92)		(2567)	(6.181)	(5.709)	(2.559)	(3.346)

Sold & Serviced By:



Toll Free Phone (877) SERV098
Toll Free Fax (877) SERV099

www.electromate.com
sales@electromate.com

▶ KP SERIES BELLOWS COUPLING



Major Features

- Higher torsional stiffness and a shorter overall length.
- Tightening only one screw per hub locks the coupling free of backlash.
- Advantageous for space constrained or blind assembly installations.
- With EASY Clamp System for easy install and un-install.

Material

- Stainless steel bellow; aluminum hubs

Technical data/Dimensions

Size KP	Nominal Torque	Moment of Inertia	Torsion Resistance	Max. Lateral Misalignment	Mass	Screw Size	Torque to Tighten Screws	Outer Diameter	Length	Bore Range	
	Nm (lb-in)	10 ⁻³ kgm ² (lb-in ²)	Nm/arcmin (lb-ft/Deg)	mm (inch)	kg (lbs)		Nm (lb-in)	mm (inch)	mm (inch)	min. mm (inch)	max. mm (inch)
KP-2	2	0.0025	0.4	0.1	0.03	M3	2	24.5/27.5	35	3	10/14
	(18)	(0.009)	(18)	(0.004)	(0.07)		(18)	(0.965)/(1.083)	(1.378)	(0.118)	(0.394)/(0.551)
KP-5	5	0.0028	0.8	0.1	0.04	M3	2	24.5/27.5	36	6	10/14
	(44)	(0.010)	(35)	(0.004)	(0.09)		(18)	(0.965)/(1.083)	(1.417)	(0.236)	(0.394)/(0.551)
KP-7	7	0.012	1.7	0.15	0.08	M4	4	34	47	6	17
	(62)	(0.04)	(75)	(0.006)	(0.18)		(35)	(1.339)	(1.850)	(0.236)	(0.669)
KP-8	8	0.025	2.1	0.15	0.13	M5	7	39.5/44.5	51	6	19/24
	(71)	(0.09)	(93)	(0.006)	(0.29)		(62)	(1.555)/(1.752)	(2.008)	(0.236)	(0.748)/(0.945)
KP-12	12	0.028	2.6	0.15	0.13	M5	7	39.5/44.5	51	6	19/24
	(106)	(0.10)	(115)	(0.006)	(0.29)		(62)	(1.555)/(1.752)	(2.008)	(0.236)	(0.748)/(0.945)
KP-20	20	0.13	9	0.2	0.3	M6	14	56	61	9	30
	(177)	(0.44)	(399)	(0.008)	(0.66)		(124)	(2.205)	(2.402)	(0.354)	(1.181)
KP-25	25	0.064	4	0.15	0.18	M5	8	50	58	10	28
	(221)	(0.22)	(177)	(0.006)	(0.40)		(71)	(1.968)	(2.283)	(0.394)	(1.102)
KP-35	35	0.13	9	0.2	0.3	M6	14	56	61	14	30
	(310)	(0.44)	(399)	(0.008)	(0.66)		(124)	(2.205)	(2.402)	(0.551)	(1.181)
KP-60	60	0.27	14	0.2	0.4	M8	35	66	67	15	34
	(531)	(0.92)	(620)	(0.008)	(0.88)		(310)	(2.598)	(2.638)	(0.591)	(1.339)
KP-100	100	0.35	20	0.2	0.5	M8	35	71	68	22	38
	(885)	(1.20)	(886)	(0.008)	(1.10)		(310)	(2.795)	(2.677)	(0.866)	(1.496)
KP-170	170	0.76	28	0.2	0.8	M10	65	82	80	22	43
	(1505)	(2.60)	(1240)	(0.008)	(1.76)		(575)	(3.228)	(3.150)	(0.866)	(1.693)
KP-270	270	2	52	0.2	1.3	M12	115	101	87	27	55
	(2390)	(6.83)	(2303)	(0.008)	(2.87)		(1018)	(3.976)	(3.425)	(1.063)	(2.165)
KP-400	400	2.15	74	0.2	1.4	M12	115	101	91	32	55
	(3540)	(7.35)	(3277)	(0.008)	(3.09)		(1018)	(3.976)	(3.583)	(1.260)	(2.165)
KP-600	600	4.5	106	0.2	2.1	M14	200	122	100	35	70
	(5310)	(15.38)	(4694)	(0.008)	(4.63)		(1770)	(4.803)	(3.937)	(1.378)	(2.756)
KP-900	900	9	156	0.2	3.5	M14	200	133	127	40	75
	(7966)	(30.75)	(6908)	(0.008)	(7.72)		(1770)	(5.236)	(5.000)	(1.575)	(2.953)

Coupling must be selected so nominal torque is higher than highest operational torque of the application (i.e., during acceleration). Bore diameters smaller than the minimum are possible but reliable transmission of nominal torque cannot be guaranteed.



▶ KLC SERIES BELLOWS COUPLINGS



Major Features

- Bellows coupling with radial clamping hubs.
- Short overall length.
- Welded hub bellow connection.
- Same day delivery available.
- Low cost.

Material

- Stainless steel bellow; steel hubs

Technical data/Dimensions

Size KLC	Nominal Torque	Moment of Inertia	Torsion Resistance	Max. Lateral Misalignment	Mass	Screw Size	Torque to Tighten Screws	Outer Diameter	Length	Bore Range	
	Nm (lb-in)	10 ⁻³ kgm ² (lb-in ²)	Nm/arcmin (lb-ft/Deg)	mm (inch)	kg (lbs)		Nm (lb-in)	mm (inch)	mm (inch)	min. mm (inch)	max. mm (inch)
KLC-25	25	0.09	3.5	0.2	0.22	M5	10	50	61	10	28
	(221)	(0.31)	(154.9)	(0.008)	(0.5)		(89)	(1.969)	(2.402)	(0.394)	(1.102)
KLC-50	50	0.22	6.5	0.2	0.43	M6	18	60	67	15	34
	(443)	(0.75)	(287.7)	(0.008)	(0.9)		(159)	(2.362)	(2.638)	(0.591)	(1.339)
KLC-125	125	0.75	12	0.2	0.9	M8	40	77	81	16	43
	(1106)	(2.56)	(531.1)	(0.008)	(2)		(354)	(3.031)	(3.189)	(0.63)	(1.693)

Coupling must be selected so nominal torque is higher than highest operational torque of the application (i.e., during acceleration).
Bore diameters smaller than the minimum are possible but reliable transmission of nominal torque cannot be guaranteed.

Sold & Serviced By:

ELECTROMATE

Toll Free Phone (877) SERV098

Toll Free Fax (877) SERV099

89 www.electromate.com

sales@electromate.com

▶ KG SERIES BELLOWS COUPLING



Major Features

- Bellows coupling with radial clamping hubs.
- With EASY Clamp System for easy install and un-install.
- Short overall length.
- Also available in stainless steel versions (KG-VA)

Material

- Stainless steel bellow; steel hubs

Technical data/Dimensions

Size KG	Nominal Torque	Moment of Inertia	Torsion Resistance	Max. Lateral Misalignment	Mass	Screw Size	Torque to Tighten Screws	Outer Diameter	Length	Bore Range	
	Nm (lb-in)	10 ⁻³ kgm ² (lb-in ²)	Nm/arcmin (lb-ft/Deg)	mm (inch)	kg (lbs)		Nm (lb-in)	mm (inch)	mm (inch)	min. mm (inch)	max. mm (inch)
KG-5	5	0.004	0.9	0.1	0.06	M3	2	24	29	6	11
	(44)	(0.014)	(39.8)	(0.004)	(0.13)		(18)	(0.945)	(1.142)	(0.236)	(0.433)
KG-10	10	0.019	2.1	0.15	0.14	M4	5	34	38	8	16
	(88)	(0.065)	(92.9)	(0.006)	(0.31)		(44)	(1.339)	(1.496)	(0.315)	(0.630)
KG-20	20	0.044	3.4	0.15	0.22	M5	10	39.5	43	10	20
	(177)	(0.15)	(150)	(0.006)	(0.49)		(89)	(1.555)	(1.693)	(0.394)	(0.787)
KG-40	40	0.18	9	0.2	0.5	M6	16	56	55	12	28
	(354)	(0.62)	(398)	(0.008)	(1.1)		(142)	(2.205)	(2.165)	(0.472)	(1.102)
KG-80	80	0.44	14	0.2	0.9	M8	40	66	61	14	35
	(708)	(1.49)	(620)	(0.008)	(2.0)		(354)	(2.598)	(2.402)	(0.551)	(1.378)
KG-140	140	0.74	20	0.2	1.1	M8	40	71	62	18	40
	(1239)	(2.51)	(885)	(0.008)	(2.4)		(354)	(2.795)	(2.441)	(0.709)	(1.575)
KG-220	220	1.22	28	0.2	1.5	M10	80	82	73	20	42
	(1947)	(4.14)	(1239)	(0.008)	(3.3)		(708)	(3.228)	(2.874)	(0.787)	(1.654)
KG-350	350	2.60	52	0.2	2.4	M12	135	101	82	22	50
	(3098)	(8.81)	(2301)	(0.008)	(5.3)		(1195)	(3.976)	(3.228)	(0.866)	(1.969)
KG-700	700	5.40	106	0.2	3.4	M12	135	122	85	42	64
	(6196)	(18.3)	(4691)	(0.008)	(7.5)		(1195)	(4.803)	(3.346)	(1.654)	(2.520)
KG-1300	1300	24.8	225	0.1	8.5	M16	300	157	111	50	90
	(11506)	(81.36)	(9957)	(0.004)	(18.7)		(2655)	(6.181)	(4.370)	(1.969)	(3.543)

Coupling must be selected so nominal torque is higher than highest operational torque of the application (i.e., during acceleration). Bore diameters smaller than the minimum are possible but reliable transmission of nominal torque cannot be guaranteed.

Sold & Serviced By:

 ELECTROMATE

Toll Free Phone (877) SERV098

Toll Free Fax (877) SERV099

www.electromate.com

sales@electromate.com



LOW COST SERVO COUPLING EKC SERIES ELASTOMER COUPLING



Major Features

- Low cost elastomer coupling for motion control applications
- Quick standard delivery (same day delivery available)
- Star-shaped elastomer element with involute tooth profile and high shore hardness ensures zero backlash over life of product.
- Elastomer spider compensates for small shaft misalignments.
- Available to purchase online!

Material

- Anodized aluminum hubs and polyurethane 92 Shore A, 98 Shore A, and 72 Shore D spiders available

Technical data/Dimensions

Coupling Size	Rated Torque* Nm (lb-in)	Elastomer	Elastomer Color (Red is standard)	Moment of Inertia 10^{-3}kgm^2 (lb-in ²)	Torsion Resistance Nm/arcmin (lb-ft/Deg)	Max. Lateral Misalignment mm (inch)	Mass kg (lbs)	Torque to Tighten Screws Nm (lb-in)	Bore Range (D)		Standard Bore Sizes
									min.	max.	
								mm (inch)	mm (inch)		
EKC-5	5 (44)	92 Sh A	Yellow	0.0060 (0.0204)	0.008 (0.35)	0.15 (0.0059)	0.045 (0.1)	5.65 (50)	5 (0.1969)	15 (0.5906)	6, 8, 10, 11, 12, 14 0.25", 0.375", 0.5"
		98 Sh A	Red		0.013 (0.58)	0.09 (0.0035)					
		72 Sh D	White		0.018 (0.81)	0.04 (0.0016)					
EKC-25	25 (221)	92 Sh A	Yellow	0.0407 (0.1390)	0.109 (4.84)	0.1 (0.0039)	0.14 (0.31)	13.00 (115)	8 (0.3150)	20 (0.7874)	10, 11, 12, 14, 16, 19, 20 0.375", 0.5", 0.625", 0.75"
		98 Sh A	Red		0.182 (8.06)	0.06 (0.0024)					
		72 Sh D	White		0.255 (11.29)	0.03 (0.0012)					
EKC-35	35 (310)	92 Sh A	Yellow	0.1667 (0.5696)	0.268 (11.869)	0.14 (0.0055)	0.28 (0.62)	13.00 (115)	13 (0.5118)	28 (1.1024)	14, 16, 19, 20, 24, 28 0.5", 0.625", 0.75", 1"
		98 Sh A	Red		0.447 (19.78)	0.1 (0.0039)					
		72 Sh D	White		0.626 (27.69)	0.05 (0.0020)					
EKC-80	80 (708)	92 Sh A	Yellow	0.3825 (1.3071)	0.346 (15.32)	0.15 (0.0059)	0.53 (1.17)	27.68 (245)	19 (0.7480)	38.1 (1.5)	19, 20, 24, 28, 32, 35 0.75", 1", 1.25", 1.375", 1.5"
		98 Sh A	Red		0.577 (25.53)	0.11 (0.0043)					
		72 Sh D	White		0.808 (35.74)	0.06 (0.0024)					
EKC-110	110 (974)	92 Sh A	Yellow	1.1026 (3.7677)	0.661 (29.25)	0.17 (0.0067)	0.96 (2.12)	27.68 (245)	24 (0.9449)	45 (1.7717)	24, 28, 32, 35, 38, 40 1", 1.25", 1.375", 1.5"
		98 Sh A	Red		1.102 (48.76)	0.12 (0.0047)					
		72 Sh D	White		1.542 (68.26)	0.07 (0.0028)					

*Higher torques permissible at larger bores

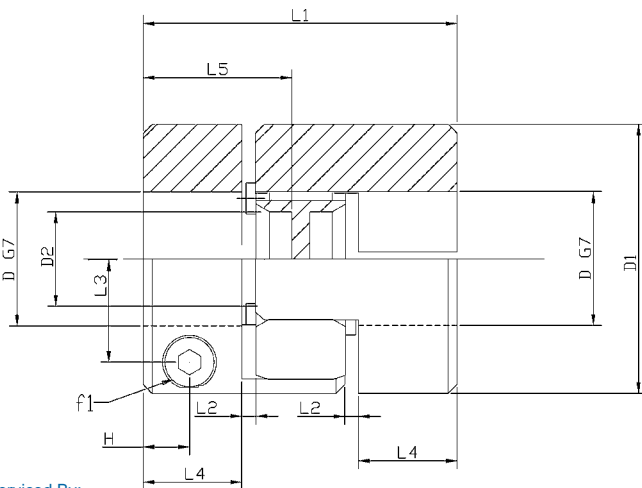

Dimension	EKC-5	EKC-25	EKC-35	EKC-80	EKC-110
	mm (in)	mm (in)	mm (in)	mm (in)	mm (in)
L1: Overall Length	35 (1.38)	66 (2.6)	78 (3.07)	90 (3.54)	114 (4.49)
L2: Gap	1.5 (0.06)	2 (0.08)	2 (0.08)	2.5 (0.10)	3 (0.12)
L3: Radial Bolt Location	10 (0.39)	14.5 (0.57)	20 (0.79)	25 (0.98)	30 (1.18)
L4: Hub Thickness	11 (0.43)	25 (0.98)	30 (1.18)	35 (1.38)	45 (1.77)
L5: Engagement	16.5 (0.65)	31.5 (1.24)	37.5 (1.475)	43 (1.69)	55 (2.165)
D1: Hub OD	30 (1.18)	40 (1.57)	55 (2.17)	65 (2.56)	80 (3.15)
D1*: Overall OD (w/ bolts)	32 (1.26)	45 (1.77)	57 (2.24)	72 (2.83)	83 (3.27)
D2: Elastomer ID	10.5 (0.41)	18 (0.71)	27 (1.06)	30 (1.18)	38 (1.5)
H: Axial Bolt Location	5 (0.2)	11 (0.43)	10.5 (0.41)	11.5 (0.45)	15.5 (0.61)
f1: Screw Size	M4	M6	M6	M8	M8

Red: 98 Shore A

Yellow: 92 Shore A

White: 72 Shore D



Sold & Serviced By:

ELECTROMATE

Toll Free Phone (877) SERV098
Toll Free Fax (877) SERV099

www.electromate.com
sales@electromate.com

Coupling must be selected so rated torque is higher than highest operational torque of the application (i.e., during acceleration).

▶ EKM SERIES ELASTOMER COUPLINGS



Major Features

- Easy-to-mount radial clamping hubs.
- Star-shaped elastomer element with involute tooth profile and high shore hardness ensures zero backlash over life of product.
- Electrically insulating and dampens oscillation resonance.
- Elastomer spider compensates for small shaft misalignments.
- Same day delivery available.

Material

- Aluminum hubs; polyurethane 72 Shore D spider
- Aluminum hubs; polyurethane 98 Shore A spider

Technical data/Dimensions

Size EKM	Nominal Torque	Elastomer Hardness Shore	Moment of Inertia	Torsion Resistance	Max. Lateral Misalignment	Mass	Screw Size	Torque to Tighten Screws	Outer Diameter	Length	Bore Range	
											min.	max.
	Nm (lb-in)		10 ⁻³ kgm ² (lb-in ²)	Nm/arcmin (lb-ft/Deg)	mm (inch)	kg (lbs)		Nm (lb-in)	mm (inch)	mm (inch)	mm (inch)	mm (inch)
MEKM-2	2 (18)	98 Sh-A	0.0002 (0.001)	0.002 (0.09)	0.1 (0.004)	0.01 (0.02)	M2	0.5 (4)	14 (0.551)	22 (0.866)	3, 4 or 5 mm	
MEKM-5	5 (44)	98 Sh-A	0.001 (0.003)	0.004 (0.18)	0.1 (0.004)	0.02 (0.04)	M2.5	1 (9)	20 (0.787)	30 (1.181)	5, 6, 8 mm or .250"	
MEKM-7	7 (62)	98 Sh-A	0.006 (0.021)	0.013 (0.58)	0.1 (0.004)	0.05 (0.11)	M4	2.5 (22)	30 (1.181)	35 (1.378)	8, 10, 12 mm or .375"	
EKM-8	8 (71)	98 Sh-A	0.01 (0.03)	0.04 (1.8)	0.1 (0.004)	0.06 (0.13)	M4	4 (35)	32 (1.260)	40 (1.575)	8 (0.315)	15 (0.591)
EKM-15	15 (133)	98 Sh-A	0.03 (0.10)	0.24 (10.6)	0.1 (0.004)	0.12 (0.26)	M5	8 (71)	40 (1.575)	50 (1.968)	10 (0.394)	19 (0.748)
EKM-20	20 (177)	72 Sh-D	0.03 (0.10)	0.34 (15.1)	0.07 (0.003)	0.12 (0.26)	M5	8 (71)	40 (1.575)	50 (1.968)	12 (0.472)	19 (0.748)
EKM-30	30 (266)	98 Sh-A	0.09 (0.31)	0.41 (18.2)	0.1 (0.004)	0.21 (0.46)	M6/M5	14/8 (124)/(71)	50 (1.968)	58 (2.283)	13 (0.512)	26/30 (1.024)/(1.181)
EKM-45	45 (398)	72 Sh-D	0.09 (0.31)	0.58 (25.7)	0.07 (0.003)	0.21 (0.46)	M6	14 (124)	50 (1.968)	58 (2.283)	18 (0.709)	26 (1.024)
EKM-60	60 (531)	98 Sh-A	0.18 (0.62)	0.61 (27.0)	0.1 (0.004)	0.32 (0.71)	M8	35 (310)	60 (2.362)	62 (2.441)	15 (0.591)	29 (1.142)
EKM-90	90 (797)	72 Sh-D	0.18 (0.62)	0.9 (39.9)	0.07 (0.003)	0.32 (0.71)	M8/M6	35/14 (310)/(124)	60 (2.362)	62 (2.441)	20 (0.787)	29/32 (1.142)/(1.259)
EKM-150	150 (1328)	98 Sh-A	0.38 (1.30)	1.05 (46.5)	0.1 (0.004)	0.52 (1.15)	M10/M8	67/35 (593)/(310)	70 (2.756)	73 (2.874)	22/30 (0.866)/(1.181)	33/38 (1.299)/(1.496)
EKM-200	200 (1770)	72 Sh-D	0.38 (1.30)	1.5 (66.4)	0.07 (0.003)	0.52 (1.15)	M10/M8	67/35 (593)/(310)	70 (2.756)	73 (2.874)	26 (1.024)	33/38 (1.299)/(1.496)
EKM-300	300 (2655)	98 Sh-A	1.0 (3.42)	2 (88.6)	0.12 (0.005)	0.9 (1.98)	M12/M10	115/67 (1018)/(593)	85 (3.346)	86 (3.386)	30/38 (1.181)/(1.496)	42/46 (1.654)/(1.811)
EKM-400	400 (3540)	72 Sh-D	1.0 (3.42)	2.85 (126.2)	0.1 (0.004)	0.9 (1.98)	M12/M10	115/67 (1018)/(593)	85 (3.346)	86 (3.386)	35 (1.378)	42/46 (1.654)/(1.811)
EKM-500	500 (4425)	98 Sh-A	2.2 (7.52)	5.8 (256.8)	0.15 (0.006)	1.5 (3.3)	M12	115 (1018)	100 (3.937)	94 (3.701)	38 (1.496)	56 (2.205)
EKM-700	700 (6196)	98 Sh-A	5.2 (17.77)	8 (354.2)	0.15 (0.006)	2.5 (5.5)	M14	185 (1637)	120 (4.724)	109 (4.291)	40 (1.575)	70 (2.756)
EKM-1000	1000 (8850)	72 Sh-D	5.2 (17.77)	12 (531.4)	0.1 (0.004)	2.5 (5.5)	M14	185 (1637)	120 (4.724)	109 (4.291)	48 (1.89)	70 (2.756)

Sold & Serviced By: **ELECTROMATE**

Toll Free Phone (877) 527-0558
 Toll Free Fax (877) 527-0559
 www.electromate.com
 sales@electromate.com

Couplings must be selected so nominal torque is higher than highest operational torque of the application (i.e., during acceleration).
 Bore diameters smaller than the minimum are possible but reliable transmission of nominal torque cannot be guaranteed.



▶ WDS SERIES BELLOWS DRIVE SHAFT COUPLING



Major Features

- Bellows drive shaft coupling with split hubs.
- Customized lengths up to 20 feet.
- High speeds, very low inertia.
- Compensation of high radial loads for prevention of premature bearing failure.

Material

- Aluminum hubs (size 15-400)
- Steel hubs (size 800-1600)
- Stainless steel bellow; aluminum tubing

Technical data/Dimensions

Size WDS	Nominal Torque	Torsional Resistance at 1.0 m	Moment of Inertia at 1.0 m	Max. Angular Misalignment	Mass at 1.0 m	Screw Size	Torque to Tighten Screws	Outer Diameter	Bore Range	
	Nm (lb-in)	Nm/arcmin (lb-ft/Deg)	10 ⁻³ kgm ² (lb-in ²)	Degrees	kg (lbs)		Nm (lb-in)	mm (inch)	min. mm (inch)	max. mm (inch)
WDS-15	15	0.4	0.2	1	0.9	2xM5	8	35	6	15
	(133)	(18)	(0.68)		(1.98)		(71)	(1.378)	(0.236)	(0.591)
WDS-50	50	1.5	0.9	1	1.8	2xM8	35	58	9	25
	(443)	(66)	(3.08)		(3.97)		(310)	(2.283)	(0.354)	(0.984)
WDS-100	100	2.6	1.8	1	2.5	2xM10	65	75	12.5	35
	(885)	(115)	(6.15)		(5.51)		(575)	(2.953)	(0.492)	(1.378)
WDS-200	200	5.9	5.3	1	3.8	2xM12	115	89	19	42
	(1770)	(261)	(18.11)		(8.38)		(1018)	(3.504)	(0.748)	(1.654)
WDS-400	400	17	12	1	7	2xM14	185	109	24	55
	(3540)	(753)	(41.01)		(15.43)		(1637)	(4.291)	(0.945)	(2.165)
WDS-800	800	26	32	1	15	4xM12	115	123	24	65
	(7081)	(1151)	(109.35)		(33.07)		(1018)	(4.843)	(0.945)	(2.559)
WDS-1600	1600	61	116	1	33	4xM16	290	158	35	85
	(14161)	(2701)	(396.39)		(72.75)		(2567)	(6.220)	(1.378)	(3.346)

Coupling must be selected so nominal torque is higher than highest operational torque of the application (i.e., during acceleration).
Bore diameters smaller than the minimum are possible but reliable transmission of nominal torque cannot be guaranteed.

Sold & Serviced By:

ELECTROMATE

Toll Free Phone (877) SERV098

Toll Free Fax (877) SERV099

93 www.electromate.com

sales@electromate.com

▶ EDC SERIES ELASTOMER DRIVE SHAFT COUPLING



Major Features

- Elastomer drive shaft coupling.
- Customized lengths up to 20 feet.
- Low cost and quick standard delivery
- Elastomer compensates for small shaft misalignments.

Material

- Anodized aluminum hubs.
- Polyurethane 92 ShoreA, 98 ShoreA, and 72 ShoreD elastomers available.

Technical data/Dimensions

Size EDC	Nominal Torque	Torsional Resistance at 1.0 m	Moment of Inertia at 1.0 m	Mass at 1.0 m	Screw Size	Torque to Tighten Screws	Outer Diameter	Bore Range	
	Nm (lb-in)	Nm/arcmin (lb-ft/Deg)	10 ⁻³ kgm ² (lb-in ²)	kg (lbs)		Nm (lb-in)	mm (inch)	min. mm (inch)	max. mm (inch)
EDC-25	25	0.112	0.200	0.878	M6	13	40	8	20
	(221)	(5)	(0.68)	(1.94)		(115)	(1.575)	(0.315)	(0.787)
EDC-35	35	0.329	0.816	1.500	M6	13	55	13	28
	(310)	(15)	(2.79)	(3.31)		(115)	(2.165)	(0.512)	(1.102)
EDC-80	80	0.447	1.351	2.249	M8	27.68	65	19	38.1
	(708)	(20)	(4.62)	(4.96)		(245)	(2.559)	(0.748)	(1.500)
EDC-110	110	0.929	3.673	3.673	M8	27.68	80	24	45
	(974)	(41)	(12.55)	(8.10)		(245)	(3.150)	(0.945)	(1.772)

Coupling must be selected so nominal torque is higher than highest operational torque of the application (i.e., during acceleration). Bore diameters smaller than the minimum are possible but reliable transmission of nominal torque cannot be guaranteed.

Sold & Serviced By:

ELECTROMATE

Toll Free Phone (877) SERV098

Toll Free Fax (877) SERV099

www.electromate.com

sales@electromate.com



SKB-KP DIRECT DRIVE BELLOWS SAFETY COUPLING



Major Features

- Bellows safety coupling with radial clamping hubs.
- Upon disengagement, coupling will re-engage automatically at only one point per revolution and retain the drive's reference point.
- Bellow compensates for axial, lateral and angular misalignment.
- Adjustable disengagement torque.

Material

- Stainless steel bellow; aluminum and steel hubs; steel safety element

Technical data/Dimensions

Size SKB-KP	Disengagement Torque Range		Moment of Inertia	Torsion Resistance	Max. Lateral Misalignment	Mass	Screw Size	Torque to Tighten Screws		Outer Diameter	Length	Switching Distance	Bore Range øD1*		Bore Range øD2**	
	Nm (lb-in)	10 ⁻³ kgm ² (lb-in ²)						Nm/ arcmin (lb-ft/Deg)	mm (inch)				kg (lbs)	*Al Hub Nm (lb-in)	**Steel Hub Nm (lb-in)	mm (inch)
SKB-KP-6	2 (18)	6 (53)	0.13 (0.44)	2.1 (93)	0.15 (0.006)	0.45 (0.99)	M5	7 (62)	10 (89)	52.5 (2.067)	81 (3.189)	0.9 (0.035)	6 (0.236)	19 (0.748)	6 (0.236)	16 (0.630)
SKB-KP-12	6 (53)	12 (106)	0.13 (0.44)	2.1 (93)	0.15 (0.006)	0.45 (0.99)	M5	7 (62)	10 (89)	52.5 (2.067)	81 (3.189)	0.9 (0.035)	8 (0.315)	19 (0.748)	8 (0.315)	16 (0.630)
SKB-KP-15	8 (71)	15 (133)	0.5 (1.71)	9 (399)	0.2 (0.008)	1 (2.20)	M6	14 (124)	18 (159)	69 (2.717)	94.5 (3.720)	1.2 (0.047)	9 (0.354)	30 (1.181)	10 (0.394)	25.4 (1.000)
SKB-KP-30	13 (115)	30 (266)	0.5 (1.71)	9 (399)	0.2 (0.008)	1 (2.20)	M6	14 (124)	18 (159)	69 (2.717)	94.5 (3.720)	1.2 (0.047)	12 (0.472)	30 (1.181)	12 (0.472)	25.4 (1.000)
SKB-KP-45	22 (195)	45 (398)	0.5 (1.71)	9 (399)	0.2 (0.008)	1 (2.20)	M6	14 (124)	18 (159)	69 (2.717)	94.5 (3.720)	1.2 (0.047)	16 (0.630)	30 (1.181)	14 (0.551)	25.4 (1.000)
SKB-KP-60	25 (221)	60 (531)	1.5 (5.13)	20 (886)	0.2 (0.008)	1.9 (4.19)	M8	35 (310)	40 (354)	88 (3.465)	107 (4.213)	1.6 (0.063)	15 (0.591)	38 (1.496)	18 (0.709)	35 (1.378)
SKB-KP-100	40 (354)	100 (885)	1.5 (5.13)	20 (886)	0.2 (0.008)	1.9 (4.19)	M8	35 (310)	40 (354)	88 (3.465)	107 (4.213)	1.6 (0.063)	20 (0.787)	38 (1.496)	18 (0.709)	35 (1.378)
SKB-KP-150	60 (531)	150 (1328)	1.5 (5.13)	20 (886)	0.2 (0.008)	1.9 (4.19)	M8	35 (310)	40 (354)	88 (3.465)	107 (4.213)	1.6 (0.063)	25 (0.984)	38 (1.496)	24 (0.945)	35 (1.378)
SKB-KP-230	80 (708)	230 (2036)	5.5 (18.79)	28 (1240)	0.2 (0.008)	3.8 (8.38)	M10	65 (575)	80 (708)	115 (4.528)	132 (5.197)	1.8 (0.071)	25 (0.984)	43 (1.693)	24 (0.945)	44 (1.732)
SKB-KP-330	130 (1151)	330 (2921)	5.5 (18.79)	28 (1240)	0.2 (0.008)	3.8 (8.38)	M10	65 (575)	80 (708)	115 (4.528)	132 (5.197)	1.8 (0.071)	32 (1.260)	43 (1.693)	32 (1.260)	44 (1.732)
SKB-KP-500	200 (1770)	500 (4425)	14 (47.84)	52 (2303)	0.2 (0.008)	6.8 (14.99)	M12/M14	115 (1018)	220 (1947)	137 (5.394)	152.5 (6.003)	2.5 (0.098)	35 (1.378)	55 (2.165)	28 (1.102)	58 (2.283)
SKB-KP-800	350 (3098)	800 (7081)	16 (54.67)	106 (4694)	0.2 (0.008)	7.2 (15.87)	M14	200 (1770)	220 (1947)	137 (5.394)	169 (6.654)	2.5 (0.098)	42 (1.654)	70 (2.756)	40 (1.575)	58 (2.283)
SKB-KP-1000	500 (4425)	1000 (8851)	80 (273.37)	80 (3542)	0.3 (0.012)	20 (44.09)	M14/M16	185 (1637)	290 (2567)	181 (7.126)	236 (9.291)	3.7 (0.146)	50 (1.968)	75 (2.953)	42 (1.654)	100 (3.937)
SKB-KP-2000	800 (7081)	2000 (17702)	88 (300.71)	140 (6199)	0.3 (0.012)	21 (46.30)	M16	290 (2567)	290 (2567)	181 (7.126)	239 (9.409)	3.7 (0.146)	65 (2.559)	85 (3.346)	45 (1.772)	100 (3.937)
SKB-KP-3000	1100 (9753)	3000 (26553)	111 (379.30)	280 (12398)	0.2 (0.008)	30 (66.14)	M16	290 (2567)	290 (2567)	181 (7.126)	263 (10.354)	3.7 (0.146)	60 (2.362)	88 (3.465)	60 (2.362)	100 (3.937)

Sold & Serviced By:



Toll Free Phone (877) SERV099
Toll Free Fax (877) SERV099

95 www.electromate.com
sales@electromate.com

SKB-EK DIRECT DRIVE ELASTOMER SAFETY COUPLING



Major Features

- Elastomer safety coupling with radial EASY Clamp System hubs.
- Upon disengagement, coupling will re-engage automatically at only one point per revolution and retain the drive's reference point.
- Star-shaped elastomer element with involute tooth profile and high shore hardness ensures zero backlash over life of product.
- Electrically insulating and dampens oscillation resonance.

Material

- Aluminum and steel hubs; elastomer spider; steel safety element

Technical data/Dimensions

Size SKB-EK	Disengagement Torque Range		Moment of Inertia	Torsion Resistance	Max. Lateral Misalignment	Mass	Screw Size	Torque to Tighten Screws		Outer Diameter	Length	Switching Distance	Bore Range øD1*		Bore Range øD2**			
	Nm (lb-in)	Nm (lb-in)	10 ⁻³ kgm ² (lb-in ²)	Nm/arcmin (lb-ft/Deg)	mm (inch)	kg (lbs)		*Al Hub	**Steel Hub				mm (inch)	mm (inch)	mm (inch)	mm (inch)	mm (inch)	mm (inch)
								Nm (lb-in)	Nm (lb-in)									
SKB-EK-6	2 (18)	6 (53)	0.13 (0.44)	0.24 (11)	0.1 (0.004)	0.44 (0.97)	M5	8 (71)	10 (89)	52.5 (2.067)	77 (3.031)	0.9 (0.035)	8 (0.315)	20 (0.787)	6 (0.236)	16 (0.630)		
SKB-EK-12	6 (53)	12 (106)	0.13 (0.44)	0.24 (11)	0.1 (0.004)	0.44 (0.97)	M5	8 (71)	10 (89)	52.5 (2.067)	77 (3.031)	0.9 (0.035)	8 (0.315)	20 (0.787)	8 (0.315)	16 (0.630)		
SKB-EK-15	8 (71)	15 (133)	0.5 (1.71)	0.61 (27)	0.1 (0.004)	1 (2.20)	M6	14 (124)	18 (159)	69 (2.717)	91.5 (3.602)	1.2 (0.047)	12 (0.472)	32 (1.260)	10 (0.394)	25.4 (1.000)		
SKB-EK-30	13 (115)	30 (266)	0.5 (1.71)	0.61 (27)	0.1 (0.004)	1 (2.20)	M6	14 (124)	18 (159)	69 (2.717)	91.5 (3.602)	1.2 (0.047)	12 (0.472)	32 (1.260)	12 (0.472)	25.4 (1.000)		
SKB-EK-45	22 (195)	45 (398)	0.5 (1.71)	0.61 (27)	0.1 (0.004)	1 (2.20)	M6	14 (124)	18 (159)	69 (2.717)	91.5 (3.602)	1.2 (0.047)	14 (0.551)	32 (1.260)	14 (0.551)	25.4 (1.000)		
SKB-EK-60	25 (221)	60 (531)	1.5 (5.13)	1.05 (46)	0.1 (0.004)	2 (4.41)	M8	35 (310)	40 (354)	88 (3.465)	107 (4.213)	1.6 (0.063)	16 (0.630)	38 (1.496)	18 (0.709)	35 (1.378)		
SKB-EK-100	40 (354)	100 (885)	1.5 (5.13)	1.05 (46)	0.1 (0.004)	2 (4.41)	M8	35 (310)	40 (354)	88 (3.465)	107 (4.213)	1.6 (0.063)	19 (0.748)	38 (1.496)	18 (0.709)	35 (1.378)		
SKB-EK-150	60 (531)	150 (1328)	1.5 (5.13)	1.05 (46)	0.1 (0.004)	2 (4.41)	M8	35 (310)	40 (354)	88 (3.465)	107 (4.213)	1.6 (0.063)	22 (0.866)	38 (1.496)	24 (0.945)	35 (1.378)		
SKB-EK-230	80 (708)	230 (2036)	5.6 (19.14)	2 (89)	0.12 (0.005)	4.2 (9.26)	M12/M10	115 (1018)	80 (708)	115 (4.528)	134 (5.276)	1.8 (0.071)	24 (0.945)	43 (1.693)	24 (0.945)	42 (1.654)		
SKB-EK-330	130 (1151)	330 (2921)	5.6 (19.14)	2 (89)	0.12 (0.005)	4.2 (9.26)	M12/M10	115 (1018)	80 (708)	115 (4.528)	134 (5.276)	1.8 (0.071)	32 (1.260)	43 (1.693)	32 (1.260)	42 (1.654)		
SKB-EK-500	200 (1770)	500 (4425)	17 (58.09)	8 (354)	0.15 (0.006)	8.6 (18.96)	M14	185 (1637)	220 (1947)	137 (5.394)	167.5 (6.594)	2.5 (0.098)	30 (1.181)	70 (2.756)	28 (1.102)	58 (2.283)		
SKB-EK-800	350 (3098)	800 (7081)	17 (58.09)	8 (354)	0.15 (0.006)	8.6 (18.96)	M14	185 (1637)	220 (1947)	137 (5.394)	167.5 (6.594)	2.5 (0.098)	42 (1.654)	70 (2.756)	40 (1.575)	58 (2.283)		
SKB-EK-1000	500 (4425)	1000 (8851)	79 (269.95)	12 (531)	0.1 (0.004)	19.5 (42.99)	M14/M16	185 (1637)	290 (2567)	181 (7.126)	204 (8.031)	3.7 (0.146)	48 (1.890)	70 (2.756)	42 (1.654)	100 (3.937)		

Sold & Serviced By:

ELECTROMATE

Toll Free Phone (877) SERV098

Toll Free Fax (877) SERV099

www.electromate.com

sales@electromate.com



SKB SERIES INDIRECT DRIVE SAFETY COUPLING



Major Features

- Pulley safety coupling with self-centering conical hub and integrated bearing.
- Upon disengagement, coupling will re-engage automatically at only one point per revolution and retain the drive's reference point.
- Integrated bearing for high axial and radial loading to support pulleys, gears or sprockets.
- Adjustable disengagement torque.

Material

- Steel hubs; steel safety element

Size SKB	Disengagement Torque Range		Moment of Inertia 10 ⁻³ kgm ² (lb-in ²)	Mass kg (lbs)	Screw Size	Torque to Tighten Screws		Thread Size for Pulley	Outer Diameter mm (inch)	Length mm (inch)	Switching Distance mm (inch)	Bore Range	
	Nm (lb-in)					Nm (lb-in)						min. mm (inch)	max. mm (inch)
SKB-6	2	6	0.09	0.36	M5	10	6xM3	52	41	0.9	6	16	
	(18)	(53)											(0.31)
SKB-12	6	12	0.09	0.36	M5	10	6xM3	52	41	0.9	8	16	
	(53)	(106)											(0.31)
SKB-15	8	15	0.36	0.8	M6	18	6xM4	69	48	1.2	10	25.4	
	(71)	(133)											(1.23)
SKB-30	13	30	0.36	0.8	M6	18	6xM4	69	48	1.2	12	25.4	
	(115)	(266)											(1.23)
SKB-45	22	45	0.36	0.8	M6	18	6xM4	69	48	1.2	14	25.4	
	(195)	(398)											(1.23)
SKB-60	25	60	1.1	1.5	M8	40	6xM6	87	55.5	1.6	18	35	
	(221)	(531)											(3.76)
SKB-100	40	100	1.1	1.5	M8	40	6xM6	87	55.5	1.6	18	35	
	(354)	(885)											(3.76)
SKB-150	60	150	1.1	1.5	M8	40	6xM6	87	55.5	1.6	24	35	
	(531)	(1328)											(3.76)
SKB-230	80	230	4.2	3.3	M10	80	6xM8	113	71.5	1.8	24	44	
	(708)	(2036)											(14.35)
SKB-330	130	330	4.2	3.3	M10	80	6xM8	113	71.5	1.8	32	44	
	(1151)	(2921)											(14.35)
SKB-500	200	500	12.2	6.2	M14	220	8xM8	136	87.5	2.5	28	58	
	(1770)	(4425)											(41.69)
SKB-800	350	800	12.2	6.2	M14	220	8xM8	136	87.5	2.5	40	58	
	(3098)	(7081)											(41.69)
SKB-1000	500	1000	76	20	M16	290	12xM10	181	142	3.7	42	100	
	(4425)	(8851)											(259.70)
SKB-2000	800	2000	76	20	M16	290	12xM10	181	142	3.7	48	100	
	(7081)	(17702)											(259.70)
SKB-3000	1500	3000	76	20	M16	290	12xM10	181	142	3.7	60	100	
	(13276)	(26552)											(259.70)

Sold & Serviced By:



Coupling must be selected so nominal torque is higher than highest operational torque of the application (i.e., during acceleration).
Bore diameters smaller than the minimum are possible but reliable transmission of nominal torque cannot be guaranteed.

Toll Free Phone (877) SERV098

Toll Free Fax (877) SERV099

97 www.electromate.com

sales@electromate.com

SKG SERIES INDIRECT DRIVE SAFETY COUPLING



Major Features

- Pulley safety coupling with self-centering conical hub and integrated bearing.
- Upon disengagement, coupling will re-engage automatically at only one point per revolution and retain the drive's reference point.
- Integrated bearing for high axial and radial loading to support pulleys, gears or sprockets.
- Adjustable disengagement torque.

Material

- Aluminum and steel hubs; steel safety element

Size SKG	Disengagement Torque Range		Moment of Inertia 10 ⁻³ kgm ² (lb-in ²)	Mass kg (lbs)	Screw Size	Torque to Tighten Screws	Outer Diameter mm (inch)	Length mm (inch)	Thread Size for Pulley	Switching Distance mm (inch)	Bore Range	
	Nm (lb-in)	Nm (lb-in)				Nm (lb-in)					min. mm (inch)	max. mm (inch)
SKG-4	2	4	0.2	0.5	M4	4	60	40	4xM4	1	12	18
	(18)	(35)				(35)						
SKG-9	4	9	0.2	0.5	M4	4	60	40	4xM4	1	12	18
	(35)	(80)				(35)						
SKG-18	9	18	0.2	0.5	M4	4	60	40	4xM4	1	12	18
	(80)	(159)				(35)						
SKG-23	9	23	0.7	1.1	M5	8	77	54	4xM6	1.4	18	25.5
	(80)	(204)				(71)						
SKG-35	18	35	0.7	1.1	M5	8	77	54	4xM6	1.4	18	25.5
	(159)	(310)				(71)						
SKG-75	25	75	0.7	1.1	M5	8	77	54	4xM6	1.4	18	25.5
	(221)	(664)				(71)						
SKG-100	50	100	1.8	1.9	M6	12	92	55	4xM6	1.4	22	39
	(443)	(885)				(106)						
SKG-170	65	170	3	2.4	M6	12	105	66	4xM6	1.7	22	39
	(575)	(1505)				(106)						
SKG-270	100	270	10.4	5	M8	35	135	85	4xM6	2.2	29	44
	(885)	(2390)				(310)						
SKG-550	200	550	10.7	5.3	M8	35	135	85	4xM6	2.2	29	44
	(1770)	(4868)				(310)						

Coupling must be selected so nominal torque is higher than highest operational torque of the application (i.e., during acceleration).
Bore diameters smaller than the minimum are possible but reliable transmission of nominal torque cannot be guaranteed.

Sold & Serviced By:



Toll Free Phone (877) SERV098
Toll Free Fax (877) SERV099
www.electromate.com
sales@electromate.com



▶ SIZING INFORMATION

Determination of the Duty Cycle (ED)

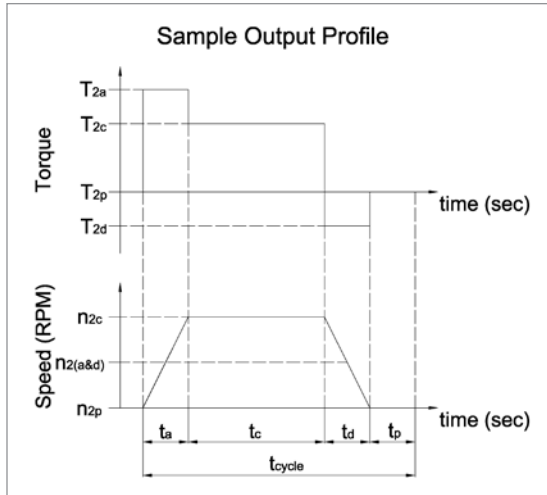

$$ED = \frac{t_a + t_c + t_d}{t_{cycle}}$$

If $ED < 60\%$ and $(t_a + t_c + t_d) < 20$ minutes, perform a cycle operation selection (S5)

If $ED > 60\%$ or $(t_a + t_c + t_d) > 20$ minutes, perform a continuous operation selection (S1)

Index	
1	Input
2	Output
a	Acceleration
B	Maximum Acceleration
c	Constant
d	Deceleration
m	Mean
max	Maximum
n	Nominal
p	Pause

Symbol	Unit	Description
ED	%	Duty Cycle
fs	-	Shock Factor
i	-	Ratio
J	kg-cm ²	Moment of Inertia
n	RPM	Speed
t	s	Time
T	Nm	Torque
Zh	-	Number of Cycles
η_j	%	Efficiency

Selection of Optimum Gearbox for a Continuous Operation (S1)

Data needed before selection can be performed:

1. Output profile
2. Desired ratio (i)

Calculations to be performed:

1. Mean Output Speed

$$\Rightarrow n_{2m} = \frac{n_{2a}t_a + n_{2c}t_c + n_{2d}t_d}{t_a + t_c + t_d} = \underline{\hspace{2cm}}$$

2. Root - Mean Output Torque

$$\Rightarrow T_{2m} = \sqrt[3]{\frac{n_{2a}t_a T_{2a}^3 + n_{2c}t_c T_{2c}^3 + n_{2d}t_d T_{2d}^3}{n_{2a}t_a + n_{2c}t_c + n_{2d}t_d}} = \underline{\hspace{2cm}}$$

Selection Criteria for Gearbox:

1. Mean Output Speed must not exceed the nominal speed rating of the gearbox.

$$n_{2m} \cdot i \leq n_{1n}$$

2. Mean Output Torque must not exceed the nominal torque rating of the gearbox.

$$T_{2m} \leq T_{2n}$$

See technical data tables for values of n_{1n} and T_{2n}

Sold & Serviced By:



Toll Free Phone (877) SERV098

Toll Free Fax (877) SERV099

www.electromate.com

99 sales@electromate.com

Selection of Optimum Gearbox for a Cycle Operation (S5)

Data needed before selection can be performed:

1. Maximum Torque of the motor (T_{IB})
2. Output profile
3. Desired ratio (i)
4. Inertia of the load (J_L)*
5. Inertia of the motor (J_{motor})*

*optional

Calculation to be performed:

1. Shock Factor (f_s)

$$Z_h = \frac{3600}{t_{cycle}}$$

$Z_h < 1000$	$\Rightarrow f_s = 1.0$
$1000 < Z_h < 1500$	$\Rightarrow f_s = 1.1$
$1500 < Z_h < 2000$	$\Rightarrow f_s = 1.3$
$2000 < Z_h < 3000$	$\Rightarrow f_s = 1.6$
$3000 < Z_h <$	$\Rightarrow f_s = 2.0$

2. Maximum Output Torque

$$T_{2max} = T_{IB} \cdot i \cdot f_s \cdot \eta = \underline{\hspace{2cm}}$$

Selection Criteria for Gearbox:

1. Maximum Output Speed must not exceed the maximum speed rating of the gearbox.
2. Maximum Output Torque must not exceed the maximum torque rating of the gearbox.
3. (optional) Match inertia of the motor to the inertia of the load.

$$n_{2c} \cdot i \leq n_{1max}$$

$$T_{2max} \leq T_{2B}$$

$$J_{motor} \approx J_1 + \frac{J_L}{i^2}$$

See technical data tables for values of η , n_{1max} , T_{2B} , and J_1

Sizing and Selecting for Couplings and Safety Couplings

Sizing

1. Determine torque (M_N)

$$M_N = M_a \cdot \frac{J_{load}}{J_{load} + J_{drive}} \cdot 2.5$$

M_N Nominal Torque of Coupling

M_a Acceleration Torque of Motor

C

f Resonant frequency [Hz]

J_{mot} Motor inertia + 1/2 coupling inertia [kgm²]

J_{mod} Load inertia + 1/2 coupling inertia [kgm²]

In general $f_{coupling} \geq 2 \cdot f_{drive}$

2. Verify resonant frequency

$$f_{coupling} = \sqrt{C_{coupling}}$$

$$f_{drive} = \frac{1}{2\pi} \sqrt{C_{drive} \cdot \frac{(J_{drive} + J_{load})}{(J_{load} \cdot J_{load})}}$$

3. Apply operating temperature safety factor only for elastomer couplings

Operating Temperature	< 50°C	50°C - 70°C	70°C - 90°C	90°C - 110°C	> 110°C
Multiply M_N by	1	1.3	1.6	1.8	2

Selecting:

- 1) Determine series of coupling
- 2) Determine size of coupling based on MN
- 3) Verify shaft diameters are within range

Ordering Examples:

(When ordering, please include shaft sizes and tolerances)

Standard Coupling KM-20

DI = 14 mm k6

D2 = 1.00" +0/-0.0005", x 1/8" keyway

Safety Coupling SKB-30

DI = 19 mm k6

TA (disengagement torque) = 25 Nm

Drive Shaft Coupling WDS-I00

DI = .500" +/- .0005"

D2 = 32 mm k6

Distance Between Shafts = 915 mm

Sold & Serviced By:



Toll Free Phone (877) SERV098
Toll Free Fax (877) SERV099
www.electromate.com
sales@electromate.com



▶ ADDITIONAL PRODUCTS

Our Extensive Product Range

GAM has access to a wide variety of complementary motion control and power transmission products which expands our product range even further and makes your machine design experience easier and more efficient.

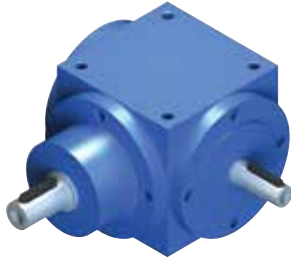

VS - Spiral Bevel Speed Increaser

- Available in 6 frame sizes from 90mm up to 260mm
- Ratios 1.5:1 to 2:1
- Multiple shaft configurations offered

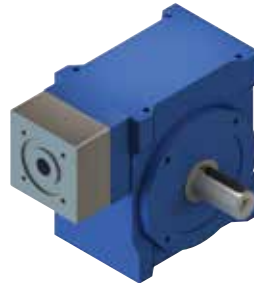

SLC - Servo Worm Gearbox

- Available in 5 frame sizes
- Input adapter suitable for servo motors
- Ratios 5:1 to 26:1
- Also available with shaft input (S-Series) which has 9 frame sizes and ratios 5:1 to 83:1

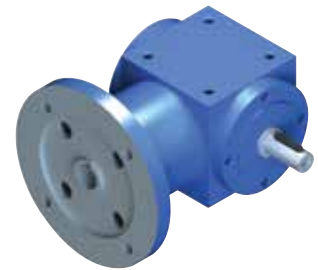

VL - Spiral Bevel with IEC Flange Input

- Available in 8 frame sizes from 65mm up to 260mm
- Input adapter suitable for IEC motor
- Keyed hollow input shaft
- Multiple shaft configurations offered

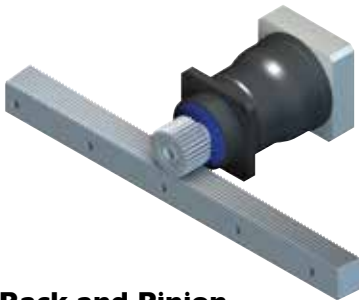

Rack and Pinion

- Helical and Straight tooth rack and pinion systems
- Common modules between 0.5mm and 6mm, with 22mm maximum
- Case-hardening, inductive hardening, and nitriding treatments available
- Contact surfaces ground



V - Multishaft

- The modular design of the V-Series makes it possible to produce a wide range of variations
- Multi-plane shaft configurations
- Ratios 1.5:1 to 6:1

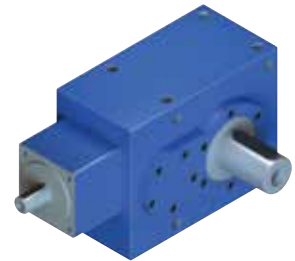

KS - Helical Bevel Gearbox

- Compact design available in 8 frame sizes
- Shaft input or adapter suitable for servo motors
- Ratios 15:1 to 75:1
- Nominal torques up to 7500Nm

Sold & Serviced By:

ELECTROMATE

Toll Free Phone (877) SERV098

Toll Free Fax (877) SERV099

101 www.electromate.com

sales@electromate.com