

FEATURES

MOTION

- Modes of motion include jogging, point-to-point positioning, contouring, linear and circular interpolation, electronic gearing and ecam
- Dual-loop control and backlash compensation
- Servo loop update rates as low as 125 microsecond/axis
- Encoder frequencies up to 8 MHz; Step motors up to 2 MHz
- Software PID control with velocity and acceleration feedforward, offsets and integration limits
- Motion Smoothing to eliminate jerk
- Linear and Circular interpolation includes ellipse scaling, slow-down around corners, infinite segment feed, feedrate override

INPUTS/OUTPUTS

- Provides main and auxiliary encoder inputs for each servo axis
- 8 uncommitted, optoisolated inputs and 8 TTL outputs for 1- through 4-axis versions
- 24 uncommitted inputs and 16 TTL outputs for 5- through 8-axis versions
- 64 TTL inputs, 32 TTL outputs with DB-10096 attachment board
- 72 I/O with DMC-1500-72 and DMC-1000-72
- 7 uncommitted analog inputs with 12-bit ADC standard; upgrade for 16-bit
- Optoisolated Forward and Reverse limits and home input for each axis
- High-speed position capture for each axis

PROGRAMMING

- On-board memory for storing application programs, variables and arrays
- Non-volatile memory for parameter storage
- Programmable event triggers including At Time, At Position, At Input, At Speed
- Automatic program execution upon power-up for stand-alone version
- Intuitive, English-like command language with over 200 commands directly executable by controller
- Multitasking for simultaneous execution of up to four applications programs
- Extensive DLLs and documentation for C/C++ programmers
- Software tools for automatic servo tuning and analysis; ActiveX controls for Visual Basic
- Drivers for Linux, QNX, DOS, and all Windows operating systems

FORMATS

- 1- through 8-axis formats
- ISA, VME cards or stand-alone box with RS232/RS422
- Controls step motors and servo motors on any combination of axes

*DMC-1500
Stand-alone
Motion Controller*



*DMC-1300
Motion Controller*

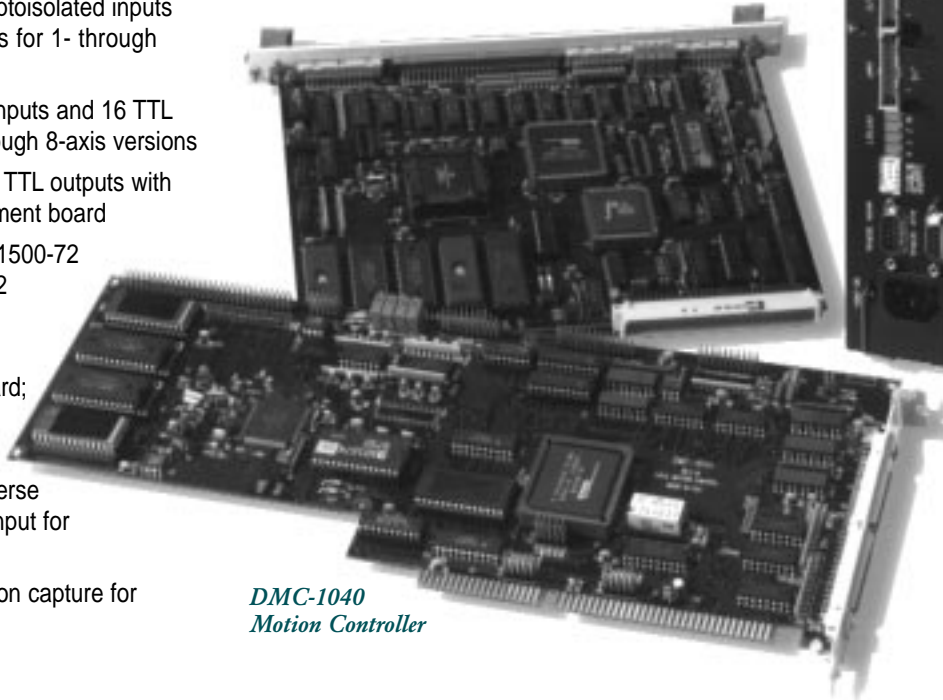

*DMC-1040
Motion Controller*

Sold & Serviced By:

 **ELECTROMATE**

Toll Free Phone (877) SERV098

Toll Free Fax (877) SERV099

www.electromate.com

sales@electromate.com

MOTION CONTROLLERS

LEGACY SERIES

DMC-1500, 1300, 1000

DESCRIPTION

Galil continues to support their Legacy Series of general-purpose controllers—which is a prior generation of controllers with a widely installed base. However, Galil does recommend their newest generation of controllers, the Optima Series, for most new applications.

The Legacy Series of controllers is available in ISA, VME and stand-alone formats in 1- through 8-axis configurations. Standard features such as uncommitted I/O, program memory with multitasking, dual encoder inputs per axis, and control of both stepper and servo motors from a single controller are supported. Modes of motion include point-to-point positioning, contouring, linear and circular interpolation, electronic gearing and ecam.

Like all Galil controllers, the Legacy Series are a great value—especially since they are as easy-to-use and cost-effective as ever before. For example, the English-like, two-letter commands are easy to learn and maintain the same format as prior generations. System setup and programming is easier than ever with such enhanced software tools as WSDK for tuning and analysis, ActiveX Tool Kit for interface to Visual Basic, and a C-Programmers Tool Kit. Also, software is compatible with Linux, DOS, QNX, and all current Windows operating systems. Finally, you get Galil's 100+ Guarantee which assures that you pay the lowest price in the market in quantities of 100 or more.

FUNCTIONAL ELEMENTS

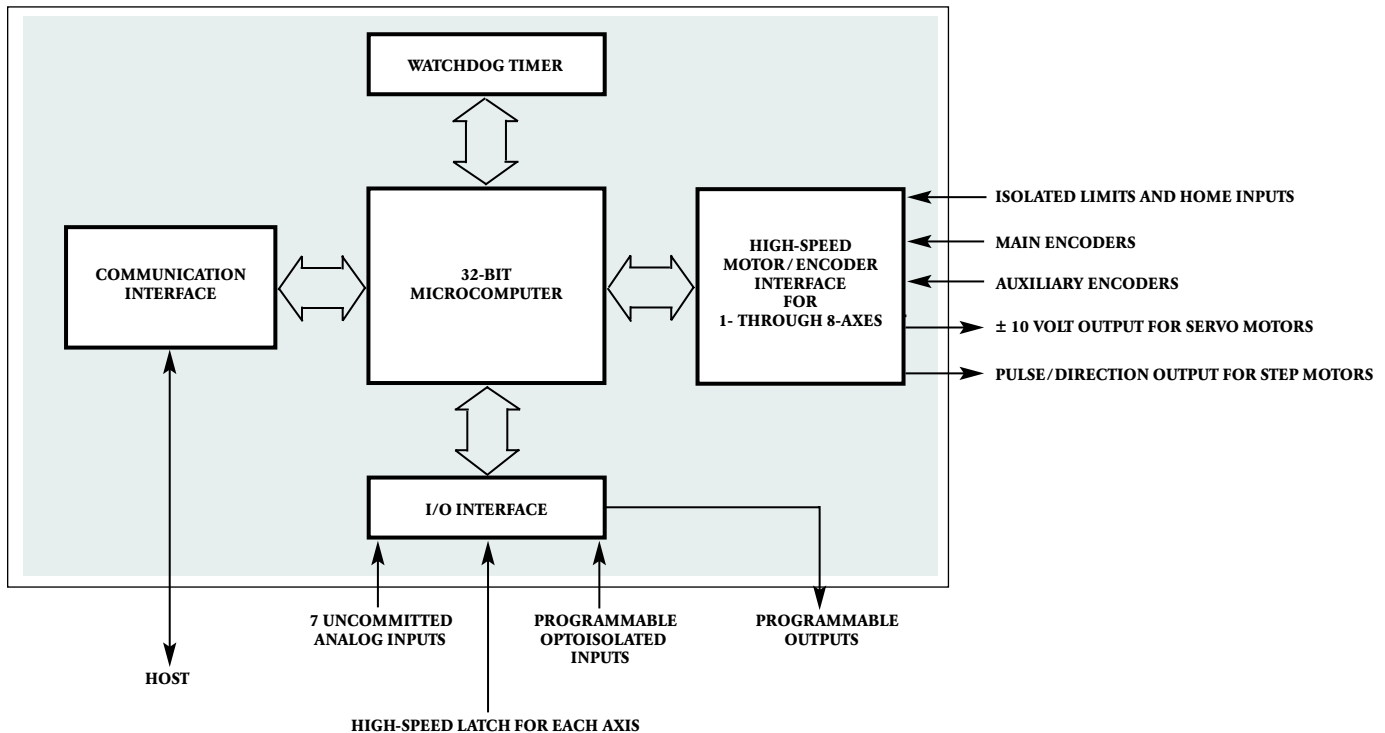

Sold & Serviced By:

 **ELECTROMATE**

Toll Free Phone (877) SERV098

Toll Free Fax (877) SERV099

www.electromate.com

sales@electromate.com

COMMAND LANGUAGE

Galil's command language is comprised of intuitive, two-letter, English-like ASCII commands designed to make programming as quick and easy as possible. For example, the "BG" command begins motion while the "SP 2000, 4000" command sets the speed of the X-axis as "2000" and the Y-axis as "4000." Commands are included for system set-up, tuning, prescribing motion, error handling and applications programming. A complete set of commands is described in the following table. Custom commands can be created upon request.

PID COMPENSATION

For best results, Galil controllers provide a compensation function which includes a PID (Proportional-Integral-Derivative) filter. The compensation also includes velocity and acceleration feedforward. All filter parameters are adjustable, allowing servo system tuning for best performance. Dual loop control is provided for reducing the effect of backlash.

PID Block Diagram

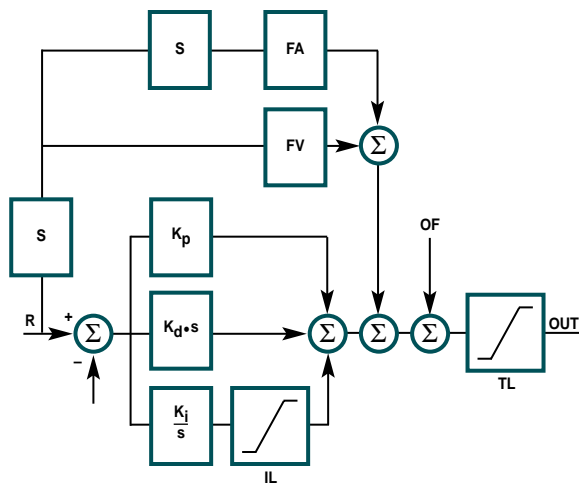

APPLICATIONS PROGRAMMING

One of the more powerful features of all Galil controllers is their ability to store and execute complex application programs as designed by the user. Such applications programs can be downloaded directly to the controller and executed without host intervention. The big benefit, of course, is that this frees the PC for other system-level tasks. In fact, Galil controllers permit multitasking, which allows up to four programs to execute simultaneously. Also, special commands are available for application programming including event triggers, conditional jumps, subroutines, symbolic variables and arrays.

Example—Change Speed on Input

Move the x-axis forward a distance of 20000 counts at an initial speed of 50000 counts/sec and with an acceleration and deceleration of 1000000 counts/sec². As soon as the motor activates the sensor connected to input 1, reduce the speed to 25000 counts/sec.

PROGRAM	INTERPRETATION
#A	<i>Label</i>
PR 20000	<i>Distance</i>
SP 50000	<i>Initial speed</i>
AC 1000000	<i>Acceleration rate</i>
DC 1000000	<i>Deceleration rate</i>
BGX	<i>Start the motion</i>
AI 1	<i>Wait for the sensor input</i>
SP 25000	<i>Reduce the speed</i>
EN	<i>End program</i>

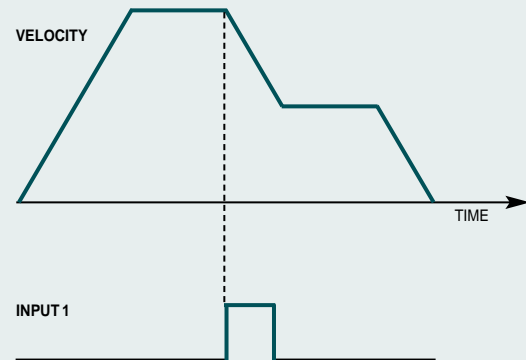

LEGACY SERIES

DMC-1500, 1300, 1000

MODES OF MOTION

Point-to-Point Motion

Any combination of axes may be operated in the Point-to-Point Motion mode to allow the target position (PA or PR), slew speed (SP), acceleration (AC) and deceleration (DC) to be specified independently for each axis. Upon begin (BG), the controller generates a trapezoidal velocity profile where the speed and acceleration can be changed anytime during motion. For applications that require smooth motion without abrupt velocity transitions, a motion smoothing function (IT) is provided. The position (TP) and position error (TE) may be interrogated at anytime.

Jogging

In the jog mode, each axis is given a jog speed and direction (JG), acceleration (AC), and deceleration (DC). Upon begin (BG), the controller ramps up to the jog speed at the prescribed acceleration following a trapezoidal profile. A smoothing function (IT) is provided to smooth abrupt velocity transitions. The stop command (ST) stops the motion at the prescribed deceleration rate. The jog speed and direction, acceleration and deceleration may be changed at anytime during motion. The average speed can be interrogated at any time using the Tell Velocity (TV) command.

Example—Jogging

COMMAND	INTERPRETATION
JG 20000,40000	Specify jog speed and direction for X and Y
AC 1000000,1000000	Specify acceleration for X and Y
DC 1000000,1000000	Specify deceleration for X and Y
BG XY	Begin motion for X and Y
WT 5000	Wait 5 seconds
JG 30000	Increase X speed
WT10000	Wait 10 seconds
ST	Stop motion on both axes

2D Linear and Circular Interpolation

The Vector Mode (VM) is an extremely powerful mode where any two-dimensional path consisting of straight-line (VP) and arc segments (CR) can be prescribed. Up to 255 segments can be given prior to motion and additional segments can be sent during motion allowing very long motion paths to be followed without stopping. The vector speed (VS), vector acceleration (VA), vector deceleration (VD), and motion smoothing (VT) are also prescribed. The vector speed can be changed at anytime during motion permitting feedrate override, slow down around corners and assignment of different speeds to specific segments. A pause during motion can easily be accomplished by setting the vector speed to zero and increasing the vector speed back to 100% to resume.

Another feature of the vector mode is tangential following which allows a third axis to remain tangent to the trajectory, which is ideal for cutting tools. Helical motion is also possible by commanding the third axis to follow the coordinated path at the same rate.

Example—Coordinated Motion

Perform a move along the trajectory shown in the figure starting at the point A and moving counter clockwise toward B. Set the vector velocity to a uniform rate of 5000 counts/sec, and set the accel/decel rate along the vector to 500000 counts/sec².

COMMAND	INTERPRETATION
#PATH	Label
VMXY	Define plane as XY
VA 500000	Acceleration
VD 500000	Deceleration
VS 5000	Vector speed
VP 4000,0	Move AB
CR 500,-90,180	Move BC
VP -1000,1000	Move CD
CR 500,90,180	Move DE
VP 0,0	Move EA
VE	Indicate end of path
BGS	Start motion sequence
EN	End program



Sold & Serviced By:



Toll Free Phone (877) SERV098

Toll Free Fax (877) SERV099

www.electromate.com

sales@electromate.com

Linear Interpolation

The linear interpolation mode (LM) allows any arbitrary path on up to 8 axes to be defined as a set of linear segments (LI). The vector speed (VS), vector acceleration (VA), vector deceleration (VD), and vector smoothing (VT) are also defined. Up to 255 LI segments can be given prior to the start of motion and additional segments can be sent during motion allowing paths of unlimited length to be followed.

Electronic Gearing

The electronic gearing mode makes it easy for Galil controllers to simulate the motion of mechanical gears electronically. Any slave axis or set of slave axes can be geared to a master at a prescribed gear ratio defined by the GR command. The gear ratio can be changed on-the-fly.

A powerful feature of electronic gearing is that an axis can be geared and do an independent or vector move simultaneously. This is useful for the position correction required in packaging applications or when shapes must be cut on a moving conveyor built.

Example—Electronic Gearing

PROGRAM	INTERPRETATION
GA Y,, Y	<i>Specify Y axis as master of X and Z</i>
GR 2,,-4	<i>Specify gear ratios for X and Z</i>
PR, 50000	<i>Specify end position of master</i>
ACY=1000000	<i>Specify acceleration of master</i>
DCY=1000000	<i>Specify deceleration of master</i>
SPY=10000	<i>Specify slew speed of master</i>
BG Y	<i>Begin motion</i>

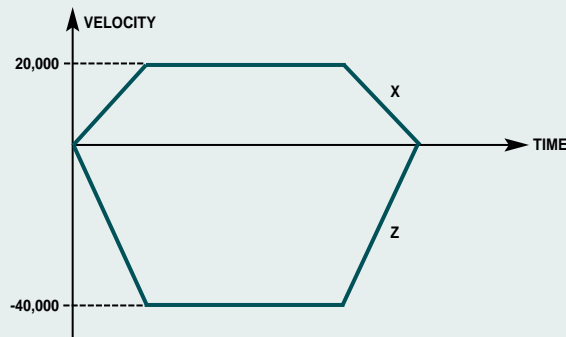

Electronic CAM

Any slave axis or set of slave axes can be linked to a master axis to simulate the motion of a mechanical CAM. The master axis may be a motor-driven axis or just a master encoder. The CAM functions are specified by a table that allows complex profiles with varying gear ratios to be prescribed. Any follower axis may be engaged or disengaged independently at specific points along a CAM cycle. This allows selecting the engagement and disengagement points as those where the speed change of the follower is minimal.

The electronic CAM is an ideal mode for periodic operation, especially those requiring varying gear ratio along the motion cycle. Such applications include flying shears, rotating knives, and packaging systems.

Contouring

The contouring mode (CM) is extremely flexible and allows any arbitrary profile on any set of axes to be prescribed. Here, the user bypasses the controller profiler and inputs the position versus time trajectory directly. The trajectory is described as the position increment (CD) over a defined time period (DT). The controller performs linear interpolation between prescribed points. The contour mode is useful for following complex, computer-generated paths or for “teaching” position paths. An automatic data-recording feature allows the controller to “learn” a path and then follow it in the contour mode.

MOTION CONTROLLERS

LEGACY SERIES

DMC-1500, 1300, 1000

OTHER FEATURES

Error Handling

Dedicated I/O are provided for safety controls: forward and reverse limit inputs for each axis, home inputs for each axis, amplifier enable outputs for each axis, abort input and error output. In addition, the controller provides safety functions in software: upper and lower software travel limits, error limits, and automatic shut-off on excess error. Program interrupts are provided for error and limit conditions. The program interrupts cause the program sequencer to automatically branch to an error handling subroutine. The error handling subroutine can be customized by the user to provide flexibility and system protection.

Dual-loop

The dual-loop (DV) feature enables the controller to compensate for mechanical backlash. Typically, dual-loop systems use a rotary encoder on the motor and a linear encoder on the load (Galil controllers accept inputs from two encoders per axis as a standard feature). Dual-loop control changes the standard PID control and closes the position loop with the load encoder ("PI") and derives the damping terms ("D") from the motor encoder. This method provides smooth and accurate control along the motion path regardless of backlash.

Dual-loop Block Diagram

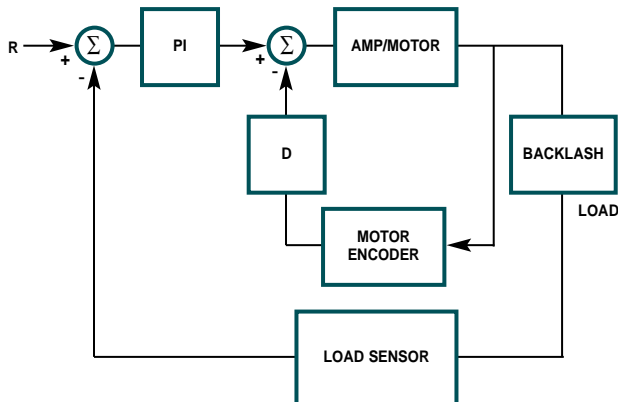

User I/O

In addition to dedicated inputs and outputs for home and limits, Galil controllers provide user I/O for synchronizing motion with external events such as switches and relays. I/O includes digital inputs, digital outputs, and analog inputs. Some controllers include I/O expansion. For example, the DMC-1540-72 four-axis controller provides eight digital outputs, eight optoisolated inputs, seven analog inputs, 48 additional digital inputs, and 24 configurable I/O. Consult the specification table for detailed I/O on various controller types. Galil controllers include many commands for handling I/O such as input interrupts, I/O triggers and timers. The combination of user I/O and application programming often eliminates the requirement for a PLC.

High-Speed Position Capture

Galil controllers provide a high-speed position capture input for each axis. This feature latches the exact position within .1 microsecond of the occurrence of an input. Either the main or auxiliary encoder may be specified for capture. Position capture is crucial for applications requiring precise synchronization of position to external events such as coordinate measurement machines.

High-Speed Position Compare—Option

The high-speed position compare feature produces an output pulse at a precise position. The starting position for the initial pulse and incremental distance for subsequent pulses are programmable. The accuracy allows for triggering external events to exact positions within .1 microseconds.

Customization

Contact Galil for any special hardware or software feature you need. We can create a custom mode of motion exactly to your specifications, design a circuit board with a special connector or design to fit space constraints. An experienced application engineer will help you develop a specification and provide you with a quotation for custom services.

Sold & Serviced By:

 **ELECTROMATE**

Toll Free Phone (877) SERV098

Toll Free Fax (877) SERV099

www.electromate.com

sales@electromate.com

SPECIFICATIONS

SYSTEM PROCESSOR AND MEMORY

DMC-1000 (1-4 axes):

- Motorola 32-bit microcomputer
- 64K RAM, 64K EPROM, 256K EEPROM

DMC-1000 (5-8 axes):

- 256K RAM, 64K EPROM, 512K EEPROM

DMC-1500, DMC-1300:

- Motorola 32-bit microcomputer
- 256K RAM, 64K EPROM, 128K EEPROM

COMMUNICATIONS INTERFACE

- *DMC-1000:* ISA with bi-directional, high speed FIFO
- *DMC-1300:* VME with dual-port RAM and vectored bus interrupts
- *DMC-1500:* Stand-alone with (2) RS232/422 up to 38.4K baud

MODES OF MOTION:

- Point-to-point positioning
- Jogging
- 2D Linear and Circular Interpolation with feedrate override
- Linear Interpolation for up to 8 axes
- Tangential Following
- Helical
- Electronic Gearing
- Electronic Cam
- Contouring
- Teach

MEMORY

DMC-1000, DMC-1300 1- through 4-axis:

- Program memory size—500 lines × 40 characters
- 126 variables
- 1600 array elements in up to 14 arrays

DMC-1300 (5- through 8-axis); DMC-1000-MX (1- through 4-axis):

- Program memory size—2000 lines × 40 characters
- 510 variables
- 8000 array elements in up to 3 arrays

DMC-1500 (1- through 8-axis); DMC-1000 (5- through 8-axis):

- Program memory size—1000 lines × 80 characters
- 254 variables
- 8000 array elements in up to 30 arrays

FILTER

- PID (proportional-integral-derivative) with velocity and acceleration feedforward
- Dual-loop control for backlash compensation
- Velocity smoothing to minimize jerk
- Integration limits
- Torque limits
- Offset adjustment

KINEMATIC RANGES

- *Position:* 32 bit (± 2.15 billion counts per move; automatic rollover; no limit in jog or vector modes)
- *Velocity:* Up to 8 million counts/sec for servo motors
- *Acceleration:* Up to 67 million counts/sec²

UNCOMMITTED DIGITAL I/O

- *1-4 axes:* 8 optoisolated inputs, 8 TTL outputs
- *5-8 axes:* 16 optoisolated inputs, 8 TTL inputs, 16 TTL outputs

UNCOMMITTED ANALOG INPUTS

- 7 individual ± 10 V analog inputs with 12-bit resolution (16-bit available as an option for DMC-1500)

HIGH SPEED POSITION LATCH

- Uncommitted inputs 1-8 latch X, Y, Z, W, E, F, G, H axes (latches within .1 microsecond if optoisolation is bypassed, within 40 μ sec with optoisolation)

DEDICATED I/O (PER AXIS)

- Main encoder inputs—Channel A, A-, B, B-, I, I- (± 12 V or TTL)
- Auxiliary encoder (for axes configured as servo)—Channel A, A-, B, B-
- Forward and reverse limit inputs—optoisolated
- Home input—optoisolated
- High-speed position latch input
- Analog motor command output with 16-bit resolution
- Pulse and direction output for step motors
- Amplifier enable output
- Error output

MINIMUM SERVO LOOP UPDATE RATE

- | | |
|----------------------------------|-----------------------------------|
| ■ <i>1 axis:</i> 250 microsecond | ■ <i>5 axis:</i> 625 microsecond |
| ■ <i>2 axis:</i> 375 microsecond | ■ <i>6 axis:</i> 750 microsecond |
| ■ <i>3 axis:</i> 500 microsecond | ■ <i>7 axis:</i> 875 microsecond |
| ■ <i>4 axis:</i> 500 microsecond | ■ <i>8 axis:</i> 1000 microsecond |

MAXIMUM ENCODER FEEDBACK RATE

- 8 MHz

MAXIMUM STEPPER RATE

- 2 MHz (Full, half or microstep)

POWER REQUIREMENTS

	<i>1-4 axis</i>	<i>5-8 axis</i>
■ +5V	750mA	1.25 A
■ -12V	40mA	60mA
■ +12V	40mA	60mA

ENVIRONMENTAL

- *Operating temperature:* 0–70° C
- *Humidity:* 20–95% RH, non-condensing

MECHANICAL

- DMC-1500 13" high × 2.5" wide × 6.6" deep; 6 lbs.

Sold & Serviced By:



Toll Free Phone (877) SERV098
Toll Free Fax (877) SERV099
www.electromate.com
sales@electromate.com

MOTION CONTROLLERS

LEGACY SERIES

DMC-1500, 1300, 1000

INSTRUCTION SET

MOTION

AB	Abort motion
AC	Acceleration
BG	Begin motion
CD	Contour data
CM	Contour mode
CR	Circle
CS	Clear motion sequence
DC	Deceleration
DT	Contour time interval
ES	Ellipse scaling
EA	Select master cam axis
EB	Enable cam mode
EG	Start cam motion
EM	Modulus for cam
EP	Master counts per table entry
EQ	Stop cam motion
ET	Cam table entry
FE	Find edge
FI	Find index
GA	Master axis for gearing
GR	Gear ratio
HM	Home
IP	Increment position
IT	Smoothing time constant-independent
JG	Jog mode
KS	Stepper smoothing
LE	Linear interpolation end
LI	Linear interpolation distance
LM	Linear interpolation mode
PA	Position absolute
PR	Position relative
SP	Speed
ST	Stop
TN	Tangent
VA	Vector acceleration
VD	Vector deceleration
VE	Vector sequence end
VM	Coordinated motion mode
VP	Vector position
VR	Vector speed ratio
VS	Vector speed
VT	Smoothing time constant-vector

PROGRAM FLOW

AD	After distance
AI	After input
AM	After motion complete
AP	After absolute position
AR	After relative distance
AS	At speed
AT	After time
AV	After vector distance
EN	End program

PROGRAM FLOW (continued)

HX	Halt task
IN	Input variable
II	Input interrupt
JP	Jump to program location
JS	Jump to subroutine
MC	After "In Position"
MF	Forward motion past position
MR	Reverse motion past position
MG	Message
NO	No operation
RE	Return from error subroutine
RI	Return from interrupt
TW	Timeout for "In Position"
WC	Wait for contour data
WT	Wait
XQ	Execute program
ZS	Zero subroutine stack

CONFIGURATION

AF	Analog feedback
AL	Arm latch
BN	Burn parameters
BP	Burn program
BV	Burn variables
CB	Clear bit
CC	Configure communication port 2
CE	Configure encoder type
CI	Communication interrupt
CN	Configure switches and stepper
CO	Configure outputs
DA	Deallocate arrays
DE	Define dual encoder position
DL	Download
DM	Dimension arrays
DP	Define position
ED	Edit mode
EO	Echo off
LS	List
LZ	Leading zeros
MO	Motor off
MT	Motor type
OB	Define output bit
OP	Output port
PF	Position format
QD	Download array
QU	Upload array
RA	Record array
RC	Record
RD	Record data
RS	Reset
SB	Set bit
UL	Upload
VF	Variable format

CONTROL FILTER SETTINGS

DV	Damping for dual loop
FA	Acceleration feedforward
FV	Velocity feedforward
GN	Gain
IL	Integrator limit
KD	Derivative constant
KI	Integrator constant
KP	Proportional constant
OF	Offset
SH	Servo here
TL	Torque limit
TM	Sample time
ZR	Zero

STATUS

RP	Report command position
RL	Report latch
SC	Stop code
TB	Tell status
TC	Tell error code
TD	Tell dual encoder
TE	Tell error
TI	Tell input
TP	Tell position
TR	Trace
TS	Tell switches
TT	Tell torque
TV	Tell velocity

ERROR AND LIMITS

BL	Reverse software limit
ER	Error limit
FL	Forward software limit
OE	Off on error

ARITHMETIC FUNCTIONS

@SIN	Sine
@COS	Cosine
@ABS	Absolute value
@FRAC	Fraction portion
@INT	Integer portion
@RND	Round
@SQR	Square root
@IN	Return digital input
@AN	Return analog input
+	Add
-	Subtract
*	Multiply
/	Divide
&	And
	Or
()	Parentheses

Sold & Serviced By:



Toll Free Phone (877) SERV098

Toll Free Fax (877) SERV099

www.electromate.com

sales@electromate.com

CONNECTORS

DMC-1000, DMC-1300, DMC-1500

Main (Axis 1-4) 60-pin IDC, Main (Axis 5-8) 60-pin IDC--included

1 Ground	2 5 V
3 Error, nc	4 Reset, nc
5 Switch common	6 Forward limit-X, E
7 Reverse limit - X, E	8 Home-X, E
9 Forward limit - Y, F	10 Reverse limit - Y, F
11 Home - Y, F	12 Forward limit - Y, F
13 Reverse limit - Z, G	14 Home - Z, G
15 Forward limit - W, H	16 Reverse limit - W, H
17 Home - W, H	18 Output 1, Output 9
19 Input common	20 Latch X , E or input 1
21 Latch Y , F or input 2	22 Latch Z , G or input 3
23 Latch W, G or input 4	24 Abort input, Input 24
25 Motor command X, E	26 Amp enable X, ,E
27 Motor command Y, F	28 Amp enable Y, F
29 Motor command Z, G	30 Amp enable Z, G
31 Motor command W, H	32 Amp enable W, H
33 A+ X, E	34 A- X, E
35 B+ X, E	36 B- X, E
37 I+ X, E	38 I- X, E
39 A+ Y, F	40 A- Y, F
41 B+ Y, F	42 B- Y, F
43 I+ Y, F	44 I- Y, F
45 A+ Z, G	46 A- Z, G
47 B+ Z, G	48 B- Z, G
49 I+ Z, G	50 I- Z, G
51 A+ W, H	52 A- W, H
53 B+ W, H	54 B- W, H
55 I+ W, H	56 I- W, H
57 +12V	58 -12V
59 5 V	60 Ground

RS-232-Main Port DMC-1500

9-pin; Standard connector and cable

1 CTS--output	6 CTS--output
2 Transmit data--output	7 RTS--input
3 Receive data--input	8 CTS--output
4 RTS--input	9 NC
5 Ground	

RS-232-Auxiliary Port DMC-1500

9-pin; Standard connector and cable

1 CTS--input	6 CTS--input
2 Transmit data--input	7 RTS--output
3 Receive data--output	8 CTS--input
4 RTS--output	9 5 V
5 Ground	

DMC-1000, DMC-1300, DMC-1500

General I/O (1-4 Axis) 26-pin IDC, (5-8Axis) 26 pin IDC--included

1 Analog 1, Input 17	2 Analog 2, Input 18
3 Analog 3, Input 19	4 Analog 4, Input 20
5 Analog 5, Input 21	6 Analog 6, Input 22
7 Analog 7, Input 23	8 Ground
9 5 V	10 Output 1, Output 9
11 Output 2, Output 10	12 Output 3, Output 11
13 Output 4, Output 12	14 Output 5, Output 13
15 Output 6, Output 14	16 Output 7, Output 15
17 Output 8, Output 16	18 Input 8, Input 16
19 Input 7, Input 15	20 Input 6, Input 14
21 Input 5, Input 13	22 Input 4, Input 12
23 Input 3, Input 11	24 Input 2, Input 10
25 Input 1, Input 9	26 Input common

DMC-1000, DMC-1300, DMC-500

Auxiliary Encoder (Axis 1-4) 20-pin IDC*,

Auxiliary Encoder (Axis 5-8) 20-pin IDC*

1 Sample clock, NC	2 Reserved
3 B- Aux W, H	4 B+ Aux W, H
5 A- Aux W, H	6 A+ Aux W, H
7 B- Aux Z, G	8 B+ Aux Z, G
9 A- Aux Z, G	10 A+ Aux Z, G
11 B- Aux Y, F	12 B+ Aux Y, F
13 A- Aux Y, F	14 A+ Aux Y, F
15 B- Aux X, E	16 B+ Aux X, E
17 A- Aux X, E	18 A+ Aux X, E
19 5 V	20 Ground

DMC-1000, DMC-1300, DMC-1500

Stepper (1-4 Axis) 20-pin IDC, (5-8Axis) 20-pin IDC*

1 Motor command X, E	2 Amp enable X, E
3 Step X,E	4 Dir X, E
5	6 Motor command Y, F
7 Amp enable Y, F	8 Step Y, F
9 Dir Y,F	10
11 Motor command Z, G	12 Amp enable Z, G
13 Step Z, G	14 Dir Z, G
15 +5V	16 Motor command W, H
17 Amp enable W, H	18 Step W, H
19 Dir W, H	20 Ground
21 Bit 30	22 Ground
23 Bit 29	24 Ground
25 Bit 28	26 Ground

**If you require 20-pin cable for auxiliary encoders or stepper motors, please specify with order.*

Sold & Serviced By:



Toll Free Phone (877) SERV098

Toll Free Fax (877) SERV099

www.electromate.com

sales@electromate.com

MOTION CONTROLLERS

LEGACY SERIES

DMC-1500, 1300, 1000

HARDWARE ACCESSORIES

■ ICM-1100 Interconnect Module

The ICM-1100 Interconnect Module breaks-out the 60-pin, 26-pin and (2) 20-pin ribbon cables into screw-type terminals for quick connection of system hardware. An ICM-1100 is required for each set of four axes. The ICM-1100 is mounted on a metal plate with dimensions of 5.7" x 13.4" x 2.5" and 1/4" diameter keyholes for mounting. The ICM is normally shipped configured for high amp enable, +5 V (-HAEN). For low amp enable, order ICM-1100-LAEN.

■ AMP-1100

The AMP-1100 series is an ICM module above with up to 4 PWM amplifiers for brush-type servo motors. Each amplifier provides 7 amps continuous, 10 amps peak at up to 80 Volts. The gain of the amplifier is 1 A/V and requires an external DC supply from 20 to 80 Volts. The minimum motor inductance is 1 mH and the PWM frequency is 30Khz.

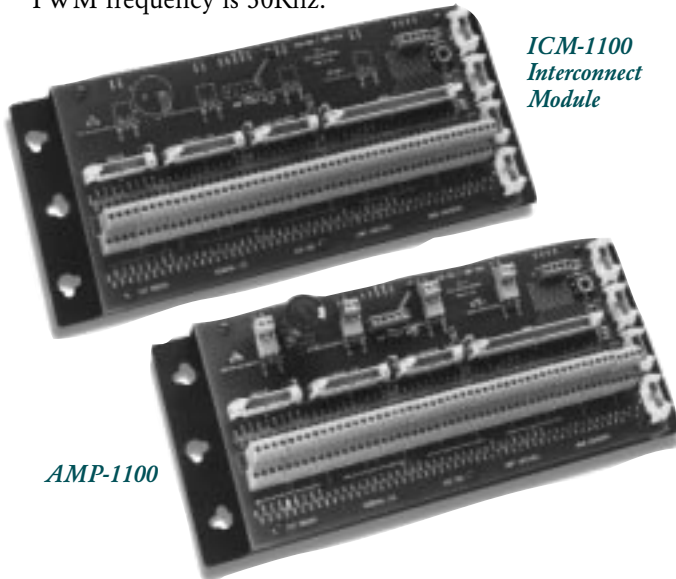

*ICM-1100
Interconnect
Module*

AMP-1100

■ DB-10072-OPTO I/O Expansion

The DB-10072-OPTO is an attachment board for the DMC-1000 that provides interface to OPTO 22 H-style racks which feature a 50-pin IDC connector. The first 48 I/O points of the DB-10072 can be configured as inputs or outputs in groups of eight. The remaining 24 points are always inputs. The DB-10072 can only be used with the 1- through 4-axis versions of the DMC-1000 ISA bus controller.

■ DB-10096-TTL I/O Expansion

The DB-10096 is an attachment board for the DMC-1000 that provides additional 64 inputs and 32 TTL-level outputs. The DB-10096 can only be used with the 1-through 4-axis versions of the DMC-1000 ISA bus controller.

■ TERM Operator Terminal

The TERM is an operator terminal for use with the DMC-1500 stand-alone controller. It provides a numeric keypad, five function keys, and a 4-line by 20-character liquid crystal display for easy data entry and display. The TERM is available as a light-weight, handheld unit or in an industrial, panel-mount configuration. It interfaces directly to the DMC-1500 RS232 port 2.



*TERM
Operator Terminal*

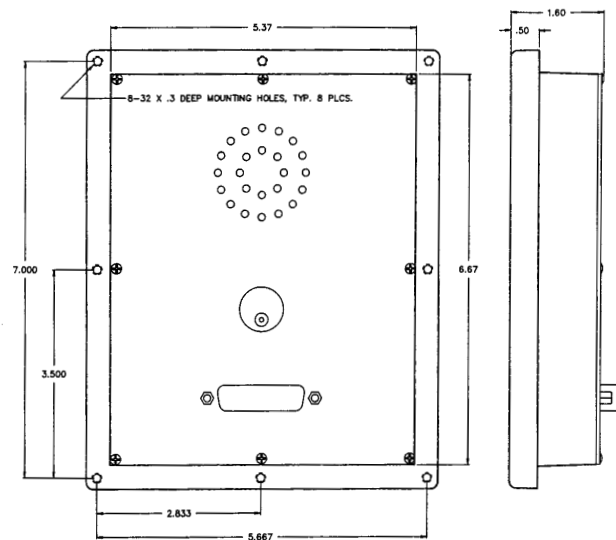

TERM-P Mounting

Sold & Serviced By:

 **ELECTROMATE**

Toll Free Phone (877) SERV098

Toll Free Fax (877) SERV099

www.electromate.com

sales@electromate.com

ORDERING INFORMATION

PART NUMBER	DESCRIPTION	QUANTITY 1	QUANTITY 100
<i>These controllers include 60-pin and 26-pin cables (please request 20-pin cables if using steppers or auxiliary encoders):</i>			
DMC-1010	1-axis ISA	\$1095	\$ 795
DMC-1020	2-axis ISA	\$1495	\$ 875
DMC-1030	3-axis ISA	\$1895	\$ 935
DMC-1040	4-axis ISA	\$2195	\$ 995
DMC-1050	5-axis ISA	\$2595	\$1345
DMC-1060	6-axis ISA	\$2795	\$1425
DMC-1070	7-axis ISA	\$2995	\$1525
DMC-1080	8-axis ISA	\$3195	\$1595
DB-10072-OPTO	Expansion for 72 OPTO I/O (1-4 axis only)	\$ 495	\$ 295
DB-10096-TTL	Expansion for 96 TTL I/O (1-4 axis only)	\$ 495	\$ 295
ICM-1100	Interconnect Module (use 1 for every set of 4 axes). Specify -HAEN for high amp enable or -LAEN for low amp enable	\$ 345	\$ 245
-MX option	Expands memory to 2000 lines, 8000 array, 510 variables (1-4 axes only)	\$ 200	\$ 50

These controllers include 60-pin and 26-pin cables (please request 20-pin cables if using steppers or auxiliary encoders):

DMC-1310	1-axis VME	\$1295	\$ 995
DMC-1320	2-axis VME	\$1695	\$1075
DMC-1330	3-axis VME	\$2095	\$1135
DMC-1340	4-axis VME	\$2395	\$1195
DMC-1350	5-axis VME	\$2795	\$1545
DMC-1360	6-axis VME	\$2995	\$1625
DMC-1370	7-axis VME	\$3195	\$1725
DMC-1380	8-axis VME	\$3395	\$1795
ICM-1100	Interconnect Module (use 1 for every set of 4 axes). Specify -HAEN for high amp enable or -LAEN for low amp enable	\$ 345	\$ 245
-MX option	Expands memory to 2000 lines, 8000 array, 510 variables (1-4 axes only)	\$ 200	\$ 50

These controllers include 60-pin and 26-pin cables, and power cable (please request 20-pin cables if using steppers or auxiliary encoders):

DMC-1510	1-axis Stand-alone	\$1395	\$1095
DMC-1520	2-axis Stand-alone	\$1895	\$1145
DMC-1530	3-axis Stand-alone	\$2495	\$1245

Ordering Information continues on the next page.

Sold & Serviced By:



Toll Free Phone (877) SERV098

Toll Free Fax (877) SERV099

www.electromate.com

sales@electromate.com

MOTION CONTROLLERS

LEGACY SERIES

DMC-1500, 1300, 1000

ORDERING INFORMATION (CONT.)

PART NUMBER	DESCRIPTION	QUANTITY 1	QUANTITY 100
DMC-1540	4-axis Stand-alone.....	\$2995	\$1395
DMC-1550	5-axis Stand-alone.....	\$3395	\$1495
DMC-1560	6-axis Stand-alone.....	\$3595	\$1645
DMC-1570	7-axis Stand-alone.....	\$3795	\$1745
DMC-1580	8-axis Stand-alone.....	\$3995	\$1845
DMC-1510-72	1-axis with 72 I/O.....	\$1895	\$1275
DMC-1520-72	2-axis with 72 I/O.....	\$2395	\$1395
DMC-1530-72	3-axis with 72 I/O.....	\$2995	\$1495
DMC-1540-72	4-axis with 72 I/O.....	\$3495	\$1645
-4MF option	Memory to save arrays.....	\$ 100	\$ 60
-16 Bit ADC	16-bit resolution upgrade for analog inputs.....	\$ 100	\$ 60
TERM-H	Hand-held terminal.....	\$ 595	\$ 415
TERM-P	Panel-mount terminal.....	\$ 945	\$ 765
ICM-1100	Interconnect Module (use 1 for every set of 4 axes). Specify -HAEN for high amp enable or -LAEN for low amp enable.....	\$ 345	\$ 245
AMP-1110	ICM with on-board, PWM amplifier for 1 brush-type servo.....	\$ 695	\$ 470
AMP-1120	ICM with on-board, PWM amplifiers for 2 brush-type servos.....	\$1045	\$ 695
AMP-1130	ICM with on-board, PWM amplifiers for 3 brush-type servos.....	\$1395	\$ 920
AMP-1140	ICM with on-board, PWM amplifiers for 4 brush-type servos.....	\$1745	\$1145
Galil Utilities	Communication drivers, terminal, DMCWIN software.....	\$ 20	
CTOOLKIT	DMCWIN with C/C++ documentation and examples.....	Included with Utilities	
WSDK	Set-up, tuning and analysis software.....	\$ 195	
ActiveX Tool Kit	Custom controls for ActiveX software such as Visual Basic.....	\$ 595	

Galil offers additional quantity discounts for purchases between 1 and 100. Consult Galil for a quotation.

Sold & Serviced By:

 **ELECTROMATE**

Toll Free Phone (877) SERV098

Toll Free Fax (877) SERV099

www.electromate.com

sales@electromate.com